



LED HIGH POWER

M13 CoB Product Series

Data Sheet

Created Date: 01 / 23 / 2014

Revision: 1.0, 01 / 23 / 2014



LED HIGH POWER M13 Product Series

1. Description

The LiteON CoB Product series is a revolutionary, energy efficient and ultra-compact new light source, combining the lifetime and reliability advantages of Light Emitting Diodes with the brightness of conventional lighting. It gives you total design freedom and unmatched brightness, creating a new opportunities for solid state lighting to displace conventional lighting technologies.

1.1 Features

- Compact high flux density light source
- Uniform high quality illumination
- Streamlined thermal path
- MacAdam compliant binning structure
More energy efficient than incandescent, halogen and fluorescent lamps
- Instant light with unlimited dimming
- RoHS compliant and Pb free

1.2 Benefits Features

- Enhanced optical control
- Clean white light without pixilation
- Uniform consistent white light
- Significantly reduced thermal resistance and increased operating temperatures
- Lower operating costs
- Reduced maintenance costs
- ESD rating is 8KV in HBM

1.3 Naming Rule

L	T	PL	-	M	1	3	7	X	X	Z	S	X	X	-	X	X
		Code1		Code2	Code3			Code4		Code5		Code6				

Code 1: Product Line

PL: High Power LED.

Code 2: Package Type/Platform

M13: Ceramic substrate with 13.35x13.35mm square.

Code 3: Light Emitting Surface

7: 6.3mm excluding dam

Code 4: Product Series

10: 10 Series

06: 06 Series

Code5: Color Temperature

27: 2700K at 85degC

30: 3000K at 85degC

40: 4000K at 85degC

50: 5000K at 85degC

57: 5700K at 85degC

Note: The Color Temperature follow ANSI C78.377A Doc.

Code6: Hue Bin by MacAdam Ellipses Step

T0: 37V, 3-Step Mac Adam Ellipse+Main Lumen Bin (2700K~4000K)

S1: 37V, 5-Step Mac Adam Ellipse/ANSI+Full Lumen Bins (2700K~4000K)

F1: 37V, 5-Step Mac Adam Ellipse+Full Lumen Bins (5000K~5700K)

S1: 37V, ANSI+Full Lumen Bins (5000K~5700K)

T2: 9V, 3-Step Mac Adam Ellipse+Main Lumen Bin (2700K~4000K)

S3: 9V, 5-Step Mac Adam Ellipse/ANSI+Full Lumen Bins (2700K~4000K)

F3: 9V, 5-Step Mac Adam Ellipse+Full Lumen Bins (5000K~5700K)

S3: 9V, ANSI+Full Lumen Bins (5000K~5700K)

LED HIGH POWER M13 Product Series

1.4 Product List

Part Number	Product Series	VF Type	CCT	CRI	Color Bin			Lumen Bin	
					3SDCM	5SDCM	ANSI	-8%~+8%	-15%~+15%
LTPL-M13706ZS27-T0	06	37V	2700K	80	☆			☆	
LTPL-M13706ZS27-S1	06	37V	2700K	80		☆	☆		☆
LTPL-M13706ZS30-T0	06	37V	3000K	80	☆			☆	
LTPL-M13706ZS30-S1	06	37V	3000K	80		☆	☆		☆
LTPL-M13706ZS40-T0	06	37V	4000K	80	☆			☆	
LTPL-M13706ZS40-S1	06	37V	4000K	80		☆	☆		☆
LTPL-M13706ZS50-F1	06	37V	5000K	80		☆			☆
LTPL-M13706ZS50-S1	06	37V	5000K	80			☆		☆
LTPL-M13706ZS57-F1	06	37V	5700K	80		☆			☆
LTPL-M13706ZS57-S1	06	37V	5700K	80			☆		☆
LTPL-M13710ZS27-T0	10	37V	2700K	80	☆			☆	
LTPL-M13710ZS27-S1	10	37V	2700K	80		☆	☆		☆
LTPL-M13710ZS30-T0	10	37V	3000K	80	☆			☆	
LTPL-M13710ZS30-S1	10	37V	3000K	80		☆	☆		☆
LTPL-M13710ZS40-T0	10	37V	4000K	80	☆			☆	
LTPL-M13710ZS40-S1	10	37V	4000K	80		☆	☆		☆
LTPL-M13710ZS50-F1	10	37V	5000K	80		☆			☆
LTPL-M13710ZS50-S1	10	37V	5000K	80			☆		☆
LTPL-M13710ZS57-F1	10	37V	5700K	80		☆			☆
LTPL-M13710ZS57-S1	10	37V	5700K	80			☆		☆
LTPL-M13706ZS27-T2	06	9V	2700K	80	☆			☆	
LTPL-M13706ZS27-S3	06	9V	2700K	80		☆	☆		☆
LTPL-M13706ZS30-T2	06	9V	3000K	80	☆			☆	
LTPL-M13706ZS30-S3	06	9V	3000K	80		☆	☆		☆
LTPL-M13706ZS40-T2	06	9V	4000K	80	☆			☆	
LTPL-M13706ZS40-S3	06	9V	4000K	80		☆	☆		☆
LTPL-M13706ZS50-F3	06	9V	5000K	80		☆			☆
LTPL-M13706ZS50-S3	06	9V	5000K	80			☆		☆
LTPL-M13706ZS57-F3	06	9V	5700K	80		☆			☆
LTPL-M13706ZS57-S3	06	9V	5700K	80			☆		☆
LTPL-M13710ZS27-T2	10	9V	2700K	80	☆			☆	
LTPL-M13710ZS27-S3	10	9V	2700K	80		☆	☆		☆

LED HIGH POWER M13 Product Series

LTPL-M13710ZS30-T2	10	9V	3000K	80	☆			☆	
LTPL-M13710ZS30-S3	10	9V	3000K	80		☆	☆		☆
LTPL-M13710ZS40-T2	10	9V	4000K	80	☆			☆	
LTPL-M13710ZS40-S3	10	9V	4000K	80		☆	☆		☆
LTPL-M13710ZS50-F3	10	9V	5000K	80		☆			☆
LTPL-M13710ZS50-S3	10	9V	5000K	80			☆		☆
LTPL-M13710ZS57-F3	10	9V	5700K	80		☆			☆
LTPL-M13710ZS57-S3	10	9V	5700K	80			☆		☆

LED HIGH POWER M13 Product Series

2. Outline Dimensions

2.1 Form Factor of M137 series CoB

06 Series - 9V

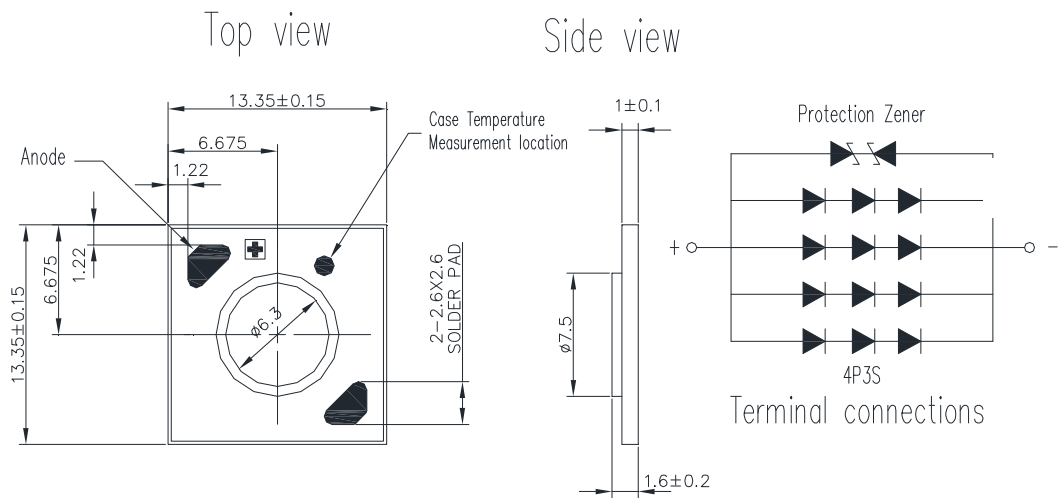

10 Series - 9V

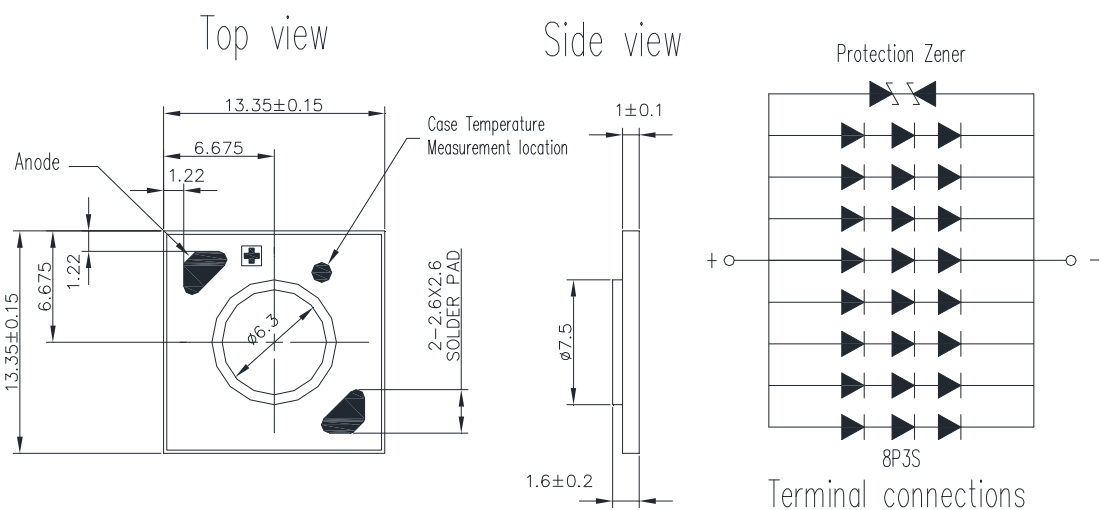

LED HIGH POWER M13 Product Series

06 Series - 37V

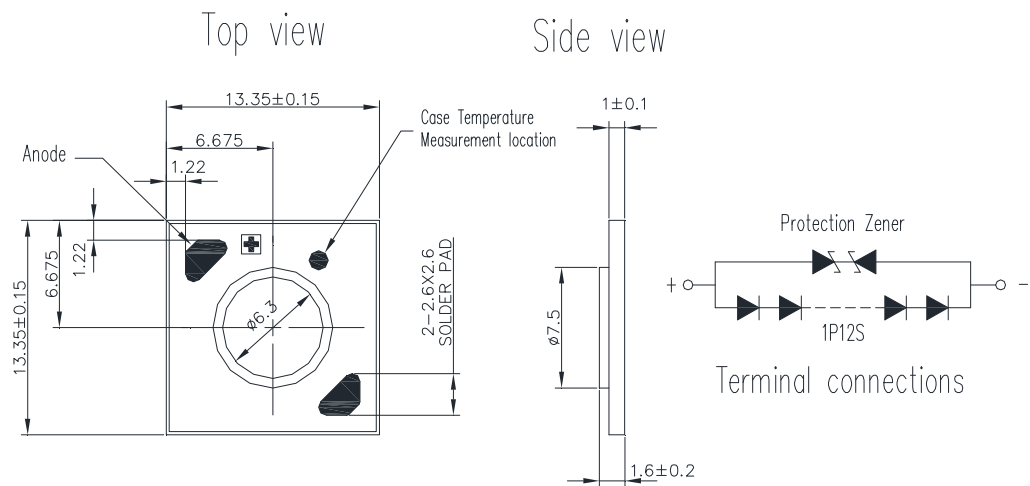

10 Series - 37V

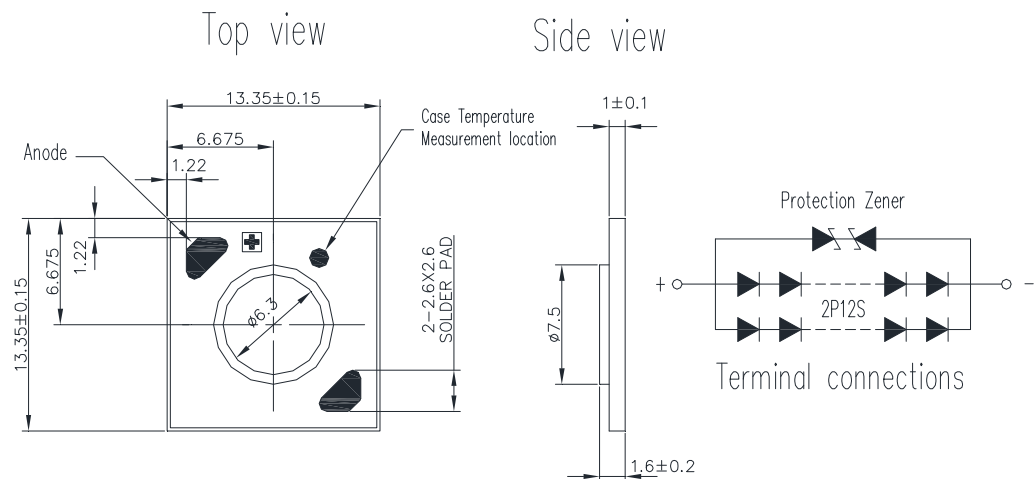

Notes

1. All dimensions are in millimeters.
2. Tolerance is ± 0.3 mm unless otherwise noted.
3. LED of equivalent circuit means all series/parallel in CoB package

LED HIGH POWER M13 Product Series

3. Absolute Maximum Ratings at Ta=25°C

Parameter	Symbol	Product Series	VF	Rating	Unit
Power Dissipation	P _O	06	37V	6.0	W
		10	37V	12.0	
		06	9V	6.0	
		10	9V	12.0	
Forward Current	I _F	06	37V	150	mA
		10	37V	300	
		06	9V	600	
		10	9V	1200	
Junction Temperature	T _j			125	°C
Thermal Resistance, Junction-Case	R _{th, J-C}	06		4.0	°C/W
		10		2.5	
Operating Temperature Range	T _{opr}			-40 to 85	°C
Storage Temperature Range	T _{stg}			-40 to 100	°C
Electrostatic Discharge	ESD			8	KV

Notes

1. The pulse mode condition is 1/10 duty cycle with 100 msec pulse width.
2. Forbid to be operated at reverse voltage condition.
3. ESD spec is reference to AEC-Q101-001 HBM.
4. The unit of R_{th} is °C/W electrical.
5. The M13 CoB is recommended soldering temperature under 350degC and could not over 3.5sec.

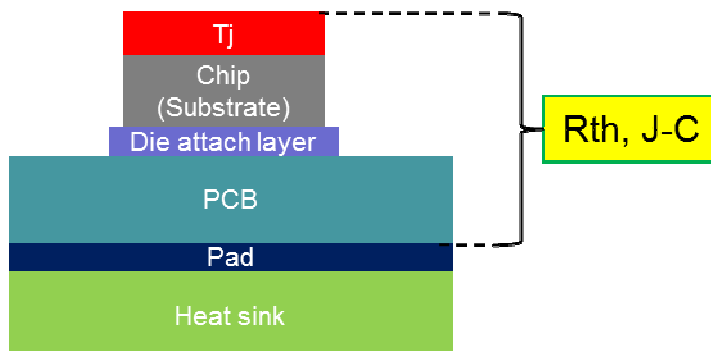

LED HIGH POWER M13 Product Series

4. Electro-Optical Characteristics

4.1 Typical Performance

■ 06 and 10 Series Product - 9V

Dominant CCT	Product Series	Current (mA)	V _F (V) @ 25°C	Flux(lm) @ 25°C	V _F (V) @ 85°C	Flux(lm) @ 85°C	Eff.(lm/W) @ 25°C	Eff.(lm/W) @ 85°C
2700K	06	400	9.2	442	8.9	398	120.1	111.4
	10	800	9.2	854	8.9	769	116.0	107.7
3000K	06	400	9.2	460	8.9	414	125.0	116.0
	10	800	9.2	890	8.9	801	120.9	112.2
4000K	06	400	9.2	488	8.9	439	132.6	123.0
	10	800	9.2	943	8.9	849	128.1	118.9
5000K	06	400	9.2	492	8.9	443	133.7	124.0
	10	800	9.2	952	8.9	857	129.3	120.0
5700K	06	400	9.2	483	8.9	435	131.3	121.8
	10	800	9.2	935	8.9	842	127.0	117.9

■ 06 and 10 Series Product - 37V

Dominant CCT	Product Series	Current (mA)	V _F (V) @ 25°C	Flux(lm) @ 25°C	V _F (V) @ 85°C	Flux(lm) @ 85°C	Eff.(lm/W) @ 25°C	Eff.(lm/W) @ 85°C
2700K	06	100	36.8	442	35.7	398	120.1	111.4
	10	200	36.8	854	35.7	769	116.0	107.7
3000K	06	100	36.8	460	35.7	414	125.0	116.0
	10	200	36.8	890	35.7	801	120.9	112.2
4000K	06	100	36.8	488	35.7	439	132.6	123.0
	10	200	36.8	943	35.7	849	128.1	118.9
5000K	06	100	36.8	492	35.7	443	133.7	124.0
	10	200	36.8	952	35.7	857	129.3	120.0
5700K	06	100	36.8	483	35.7	435	131.3	121.8
	10	200	36.8	935	35.7	842	127.0	117.9

Notes

1. All of V_F value are typical, the real bin range please refer page 19 "V_F Binning Parameter".
2. All of flux value are typical, the real bin range please refer page 19 "Flux Binning Parameter".
3. Tolerance of flux is ±7%, tolerance of CCX/CCY is ±0.007, tolerance of CRI is ±2, and tolerance of V_F is ±3%.
4. Typical viewing angle is 120deg.

LED HIGH POWER M13 Product Series

4.2 Forward Current vs. Lumen Voltage

■ 06 Series Product - 9V

Current (mA)	V _F (V)	Lumen (lm)				
		2700K	3000K	4000K	5000K	5700K
100	8.4	131	137	145	146	144
120	8.4	155	162	171	173	170
200	8.7	244	255	270	272	267
300	9.0	349	363	385	388	381
400	9.2	442	460	488	492	483
500	9.4	526	548	581	586	575
600	9.6	606	631	669	676	663

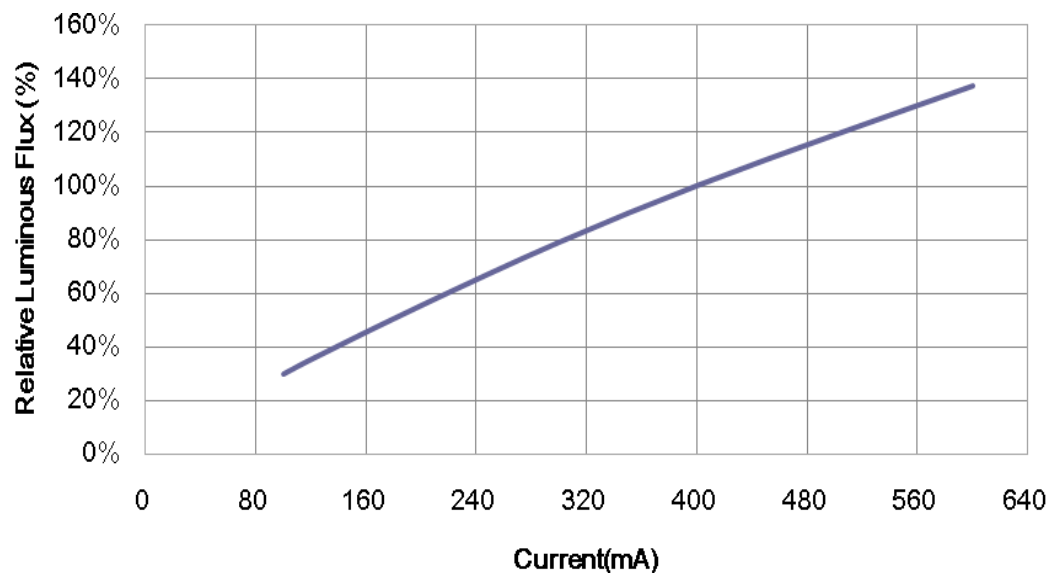

LED HIGH POWER M13 Product Series

■ 06 Series Product - 37V

Current (mA)	V_F (V)	Lumen (lm)				
		2700K	3000K	4000K	5000K	5700K
25	33.5	131	137	145	146	144
30	33.8	155	162	171	173	170
50	34.8	244	255	270	272	267
75	35.8	349	363	385	388	381
100	36.8	442	460	488	492	483
125	37.6	526	548	581	586	575
150	38.4	606	631	669	676	663

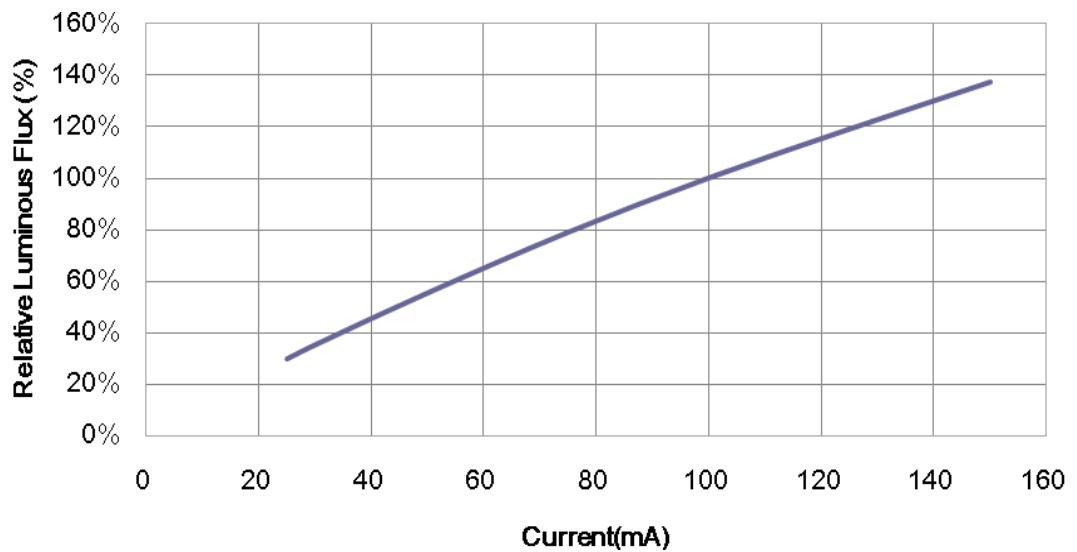

LED HIGH POWER M13 Product Series

■ 10 Series Product - 9V

Current (mA)	V _F (V)	Lumen (lm)				
		2700K	3000K	4000K	5000K	5700K
160	8.4	209	217	230	232	228
240	8.4	304	316	335	338	332
400	8.7	479	499	529	534	524
600	9.0	679	708	750	757	743
800	9.2	854	890	943	952	935
1000	9.4	1015	1058	1121	1132	1111
1200	9.6	1164	1213	1285	1297	1273

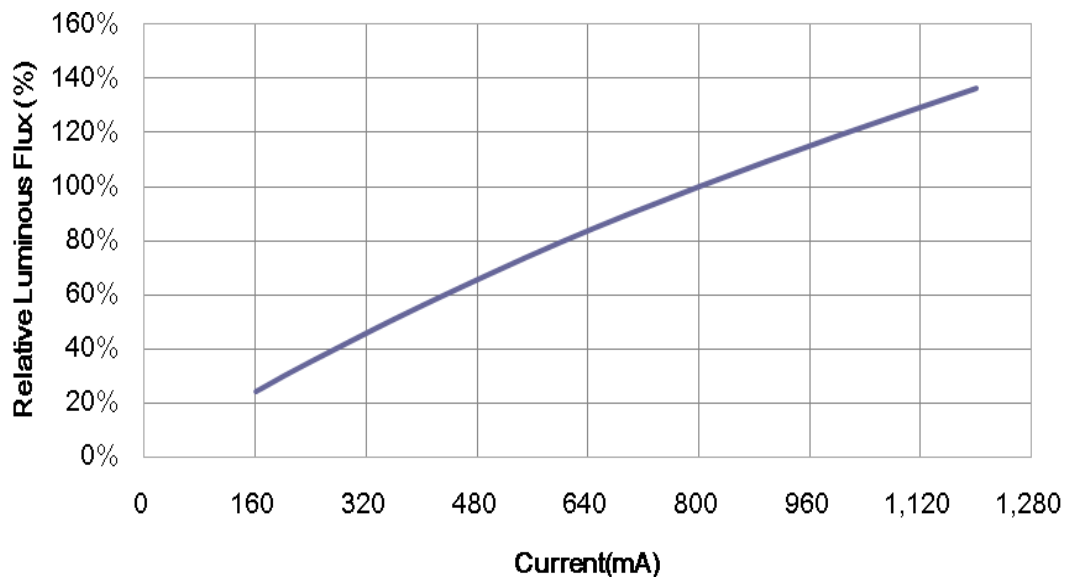

LED HIGH POWER M13 Product Series

■ 10 Series Product - 37V

Current (mA)	V_F (V)	Lumen (lm)				
		2700K	3000K	4000K	5000K	5700K
40	33.5	209	217	230	232	228
60	33.8	304	316	335	338	332
100	34.8	479	499	529	534	524
150	35.8	679	708	750	757	743
200	36.8	854	890	943	952	935
250	37.6	1015	1058	1121	1132	1111
300	38.4	1164	1213	1285	1297	1273

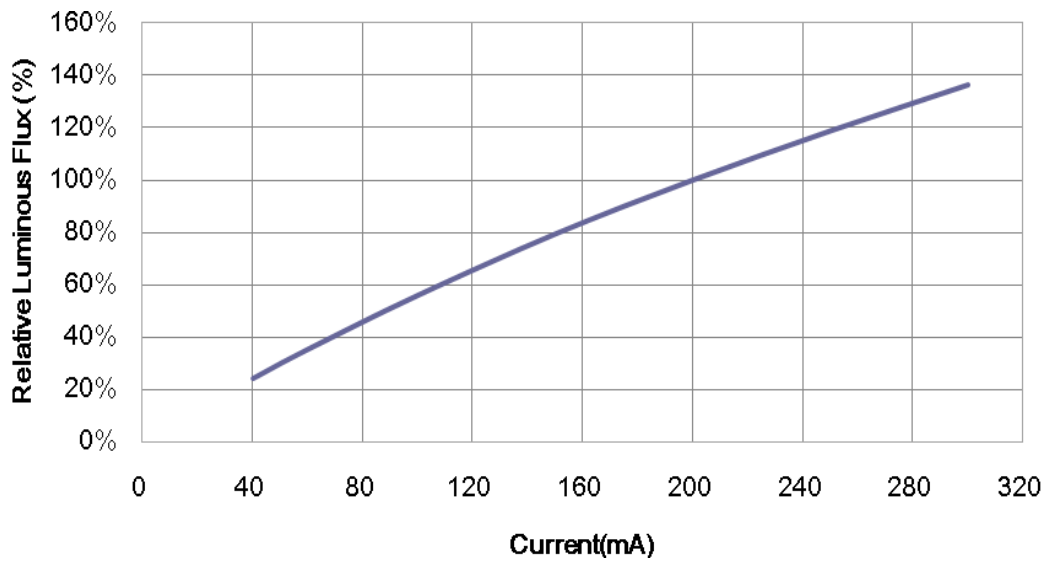

LED HIGH POWER M13 Product Series

4.3 Relative Spectral Power Distribution at Typical Current

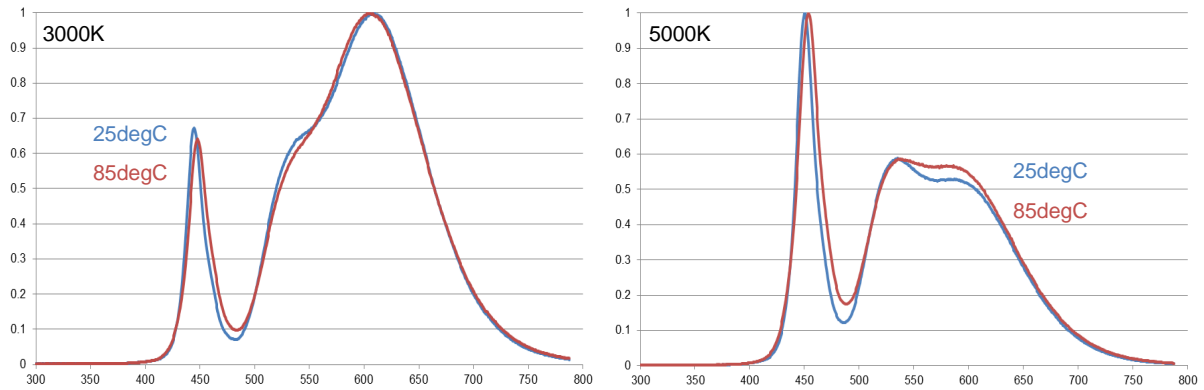

4.4 Radiation Characteristics

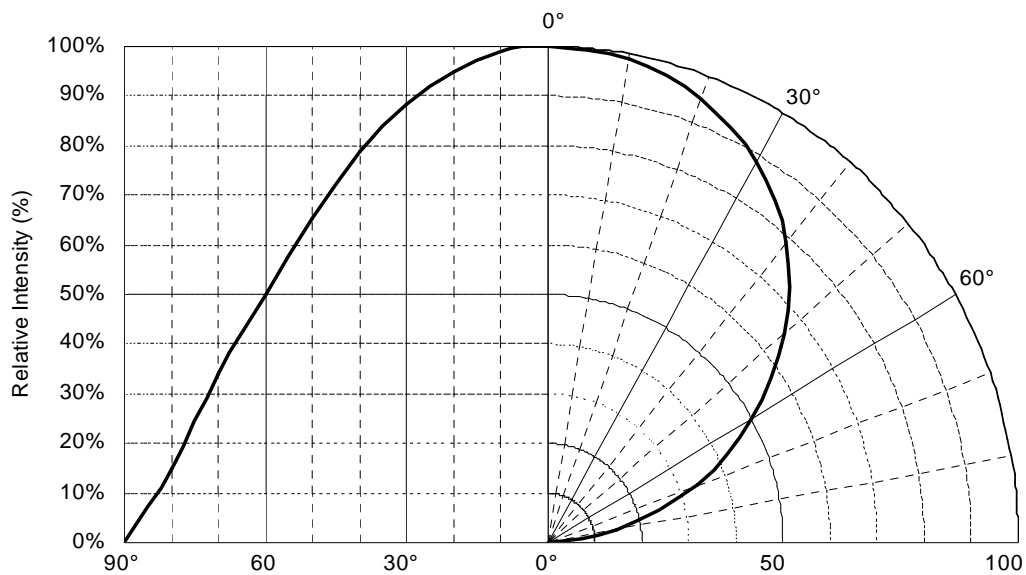

LED HIGH POWER M13 Product Series

4.5 Forward Current vs. Forward Voltage

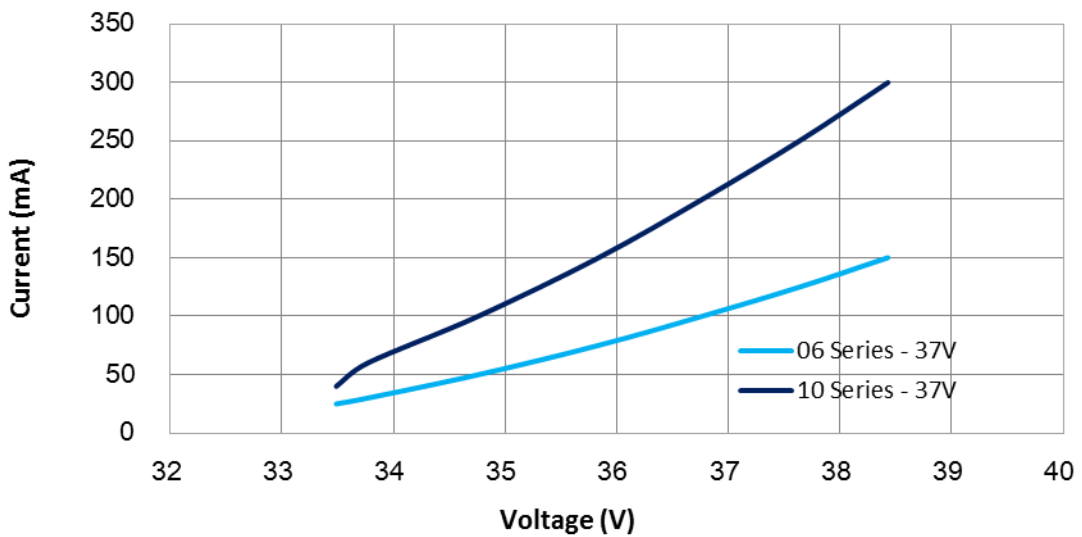
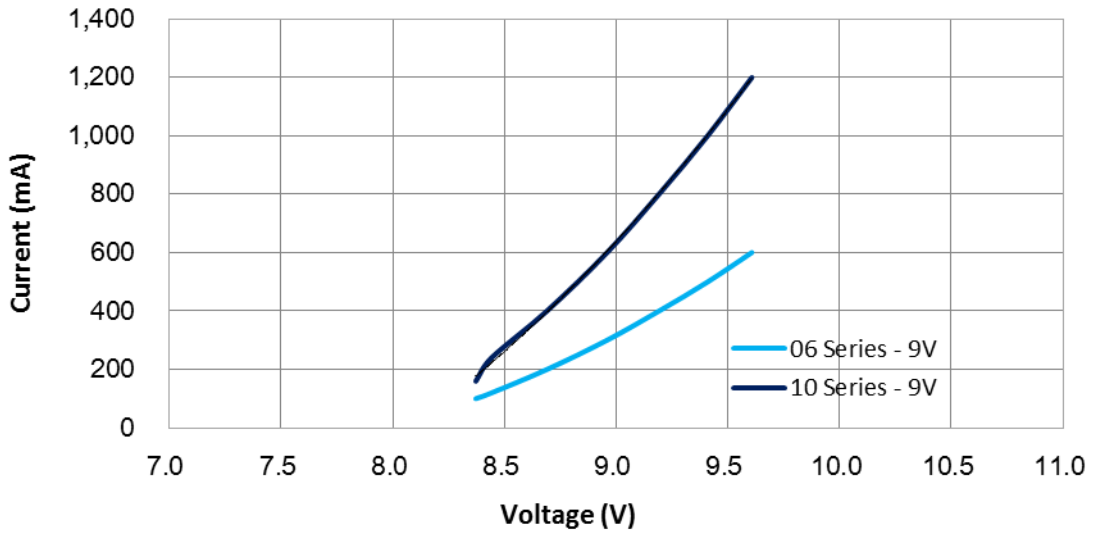

LED HIGH POWER M13 Product Series

4.6 Forward Voltage vs. Case Temperature

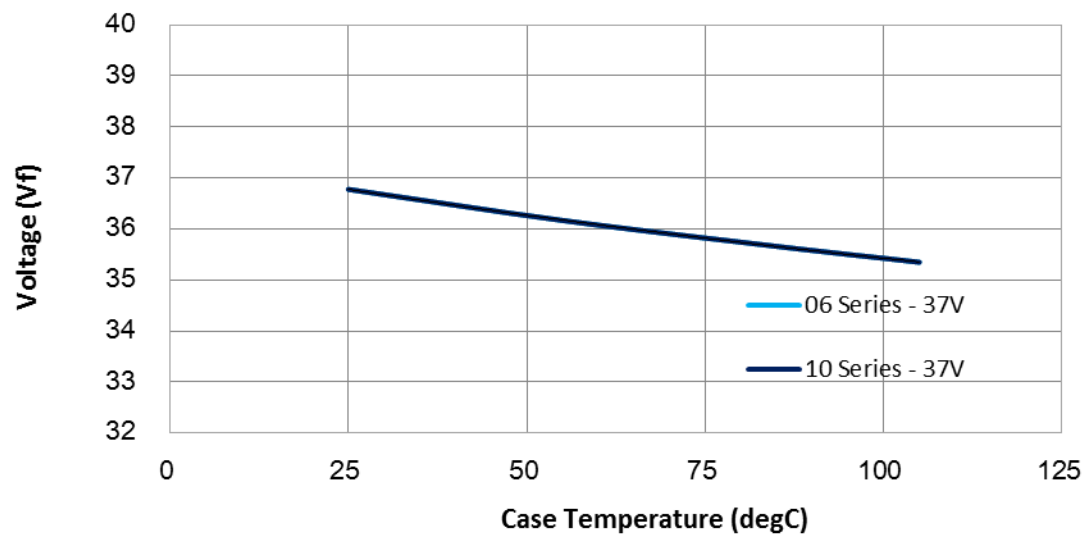
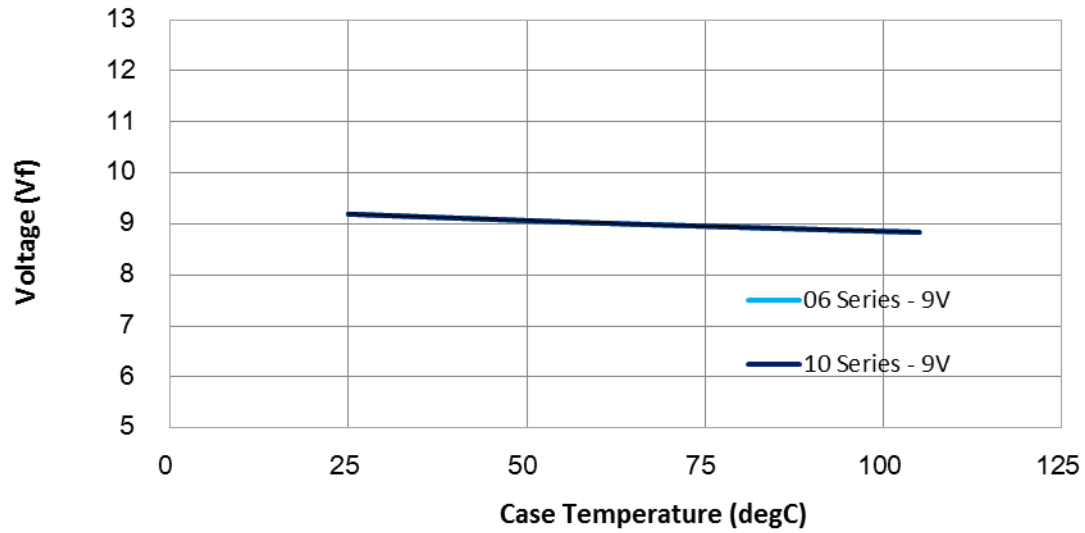

LED HIGH POWER M13 Product Series

4.7 Relative Intensity vs. Case Temperature

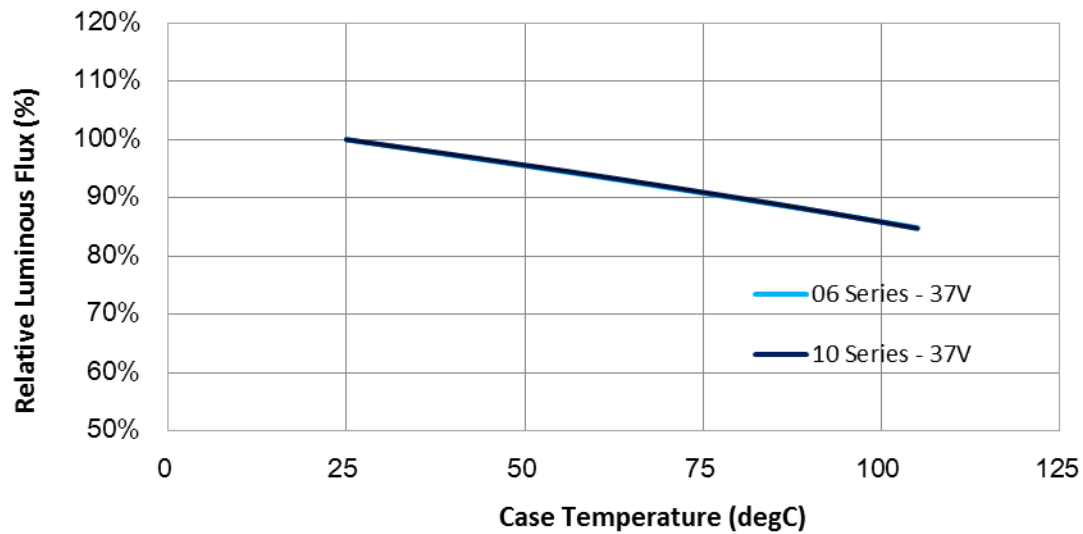
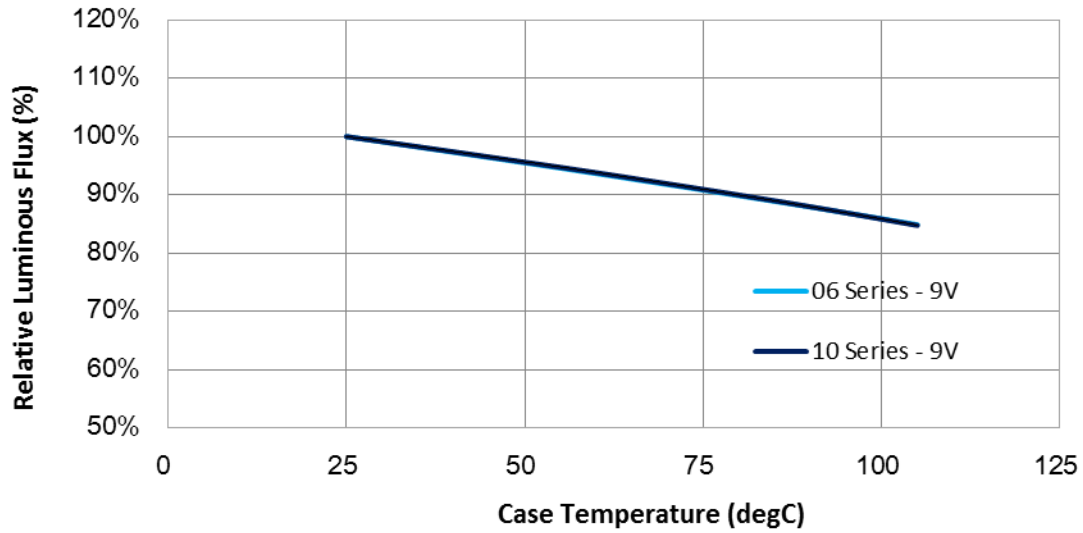

LED HIGH POWER M13 Product Series

4.8 Forward Current Degrading Curve

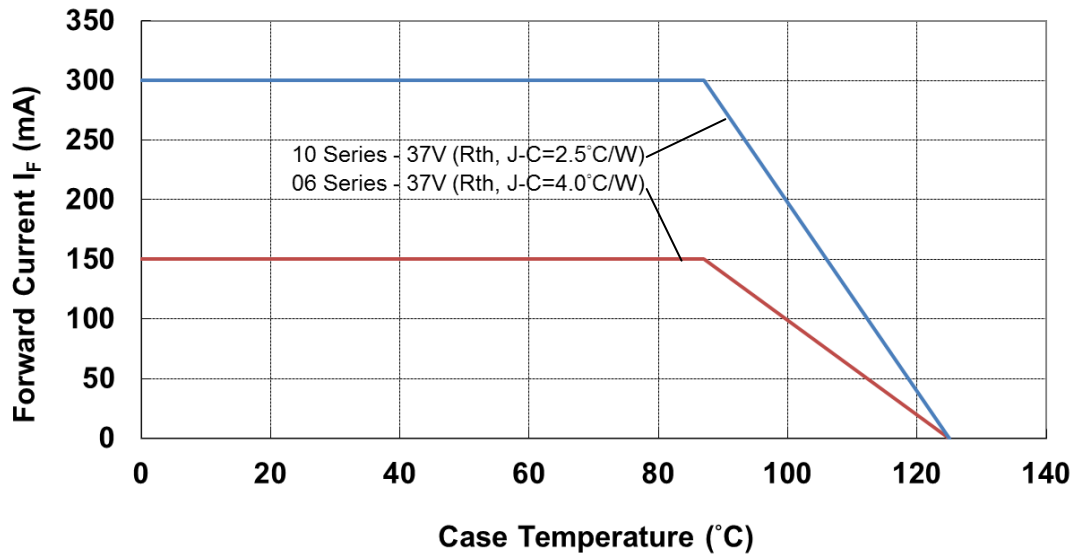
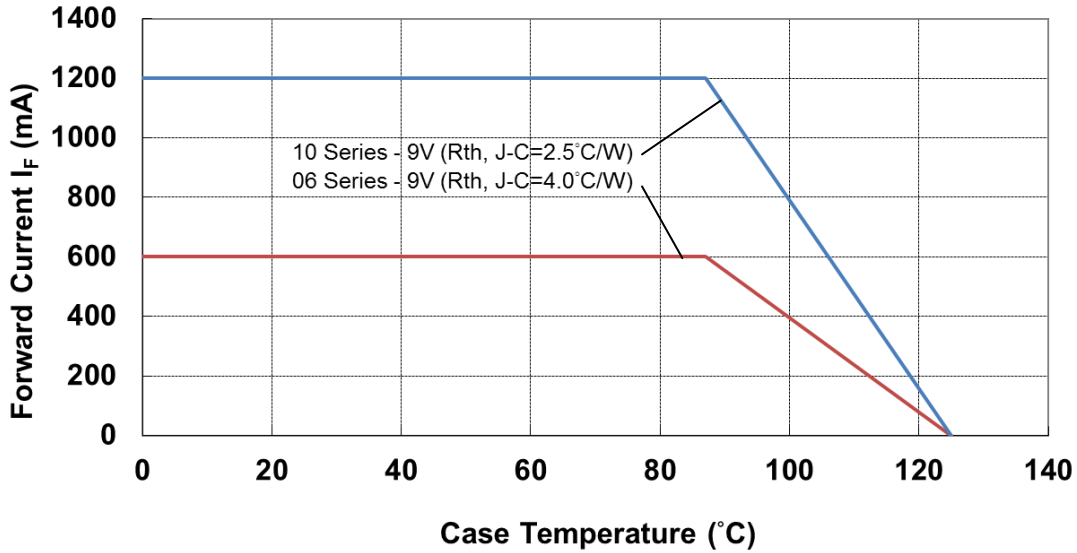

LED HIGH POWER M13 Product Series

5. CoB Binning Definition

■ Flux Binning Parameter (25degC)

Lumen CODE List of M13 Series Product			
Parameter	Code	Unit	Lumen
Luminous Flux	F	lm	365
	G		395
	H		425
	I		460
	J		495
	K		535
	L		580
	M		625
	N		675
	O		730
	P		790
	Q		850
	R		920
	S		990
	T		1070
	U		1155

■ Example of M137 Series Product Bin (2700K 06 series)

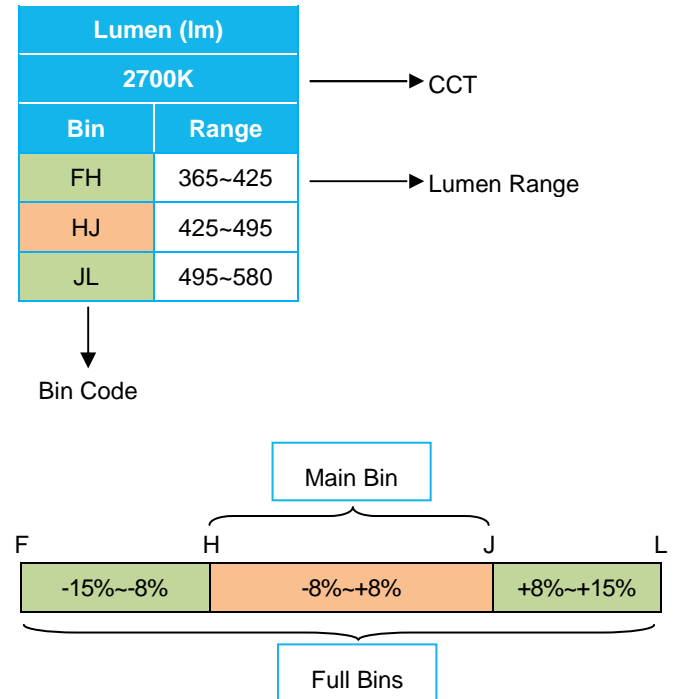

LED HIGH POWER M13 Product Series

■ 06 Series Lumen Bin - 9V and 37V

Lumen (lm)									
2700K		3000K		4000K		5000K		5700K	
Bin	Range	Bin	Range	Bin	Range	Bin	Range	Bin	Range
FH	365~425	FH	365~425	GI	395~460	GI	395~460	GI	395~460
HJ	425~495	HJ	425~495	IK	460~535	IK	460~535	IK	460~535
JL	495~580	JL	495~580	KM	535~625	KM	535~625	KM	535~625

■ 10 Series Lumen Bin - 9V and 37V

Lumen (lm)									
2700K		3000K		4000K		5000K		5700K	
Bin	Range	Bin	Range	Bin	Range	Bin	Range	Bin	Range
NP	675~790	NP	675~790	OQ	730~850	OQ	730~850	OQ	730~850
PR	790~920	PR	790~920	QS	850~990	QS	850~990	QS	850~990
RT	920~1070	RT	920~1070	SU	990~1155	SU	990~1155	SU	990~1155

■ Forward Voltage Binning Parameter (25degC)

06 and 10 series products (9V)

Parameter	Bin	Symbol	Min	Max	Unit	Condition
Forward Voltage	V1	VF	8	10	V	I _F = Typical Current

06 and 10 series products (37V)

Parameter	Bin	Symbol	Min	Max	Unit	Condition
Forward Voltage	V1	VF	33	39	V	I _F = Typical Current

Note: Full Rank on Label

Example: V1/HJ/D1

Forward Voltage Rank	Luminous Flux Rank	Color Rank
V1	HJ	D1

LED HIGH POWER M13 Product Series

■ Example of LiteOn CoB MacAdam Ellipse Color Definition (EX: 2700K)

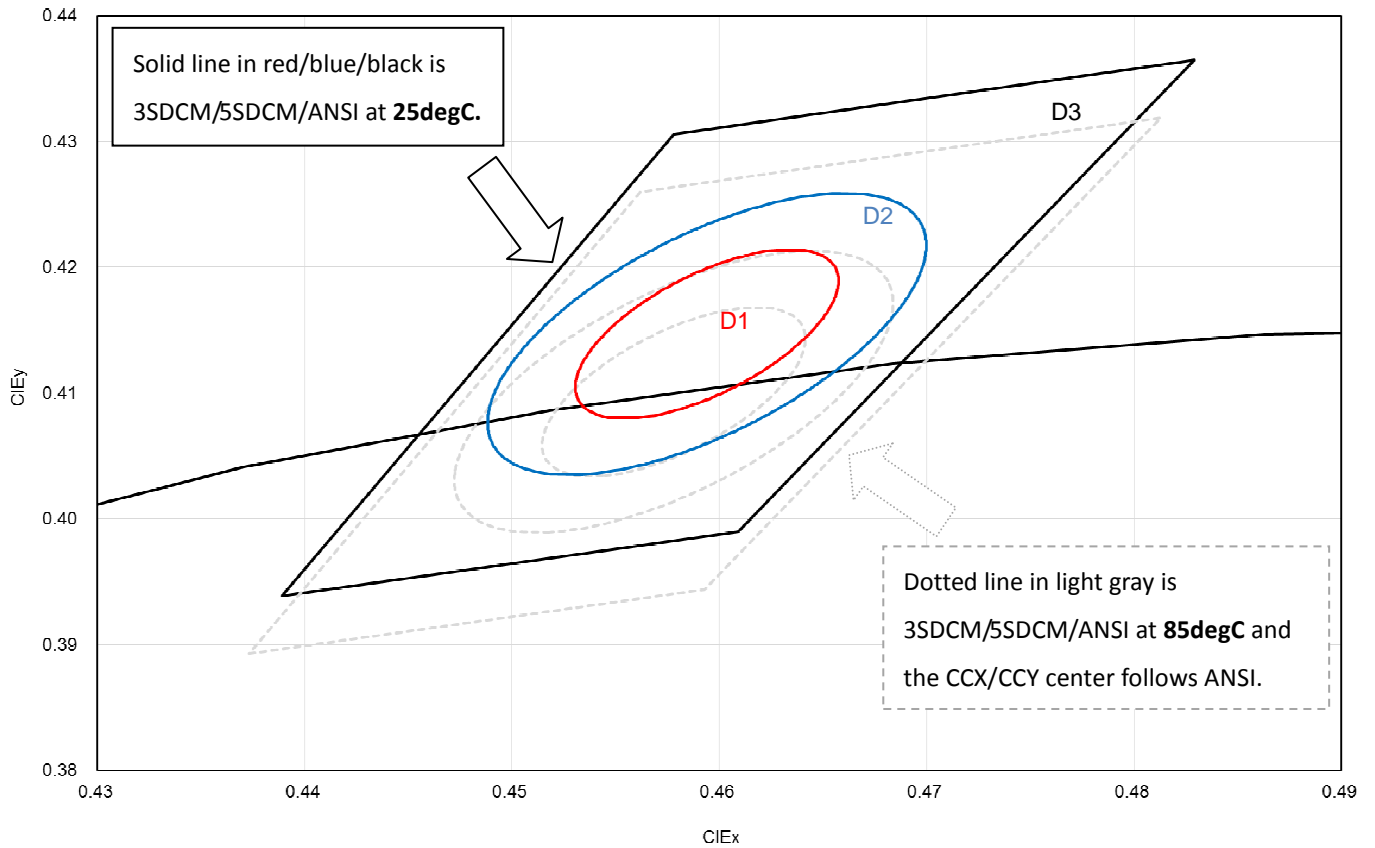

CIE Center Point						
CCT	25degC (LiteOn Spec.)		85degC (ANSI)		Hot/Cold Factor	
	CCX	CCY	CCX	CCY	CCX	CCY
2700	0.4596	0.4118	0.4578	0.4101	-0.0018	-0.0017
3000	0.4377	0.4055	0.4338	0.4030	-0.0039	-0.0025
4000	0.3864	0.3838	0.3818	0.3797	-0.0046	-0.0041
5000	0.3504	0.3614	0.3447	0.3553	-0.0057	-0.0061
5700	0.3332	0.3479	0.3287	0.3417	-0.0045	-0.0062

Notes

1. LiteOn tester and shipping spec follow the color bin with 25degC CCX/CCY center.
2. The Hot/Cold factor means the CCX/CCY shift from 25degC to 85degC.
3. The Hot/Cold shift is measured by LiteOn CAS 140B instrument system.
4. The ellipse equation expression: $SDCM = (g11*(x-x_0)^2 + 2*g12*(x-x_0)*(y-y_0) + g22*(y-y_0)^2)^{0.5}$

LED HIGH POWER M13 Product Series

■ M13 CRI80 2700K

PN: LTPL-M137XXZS27-T0 and LTPL-M137XXZS27-T2

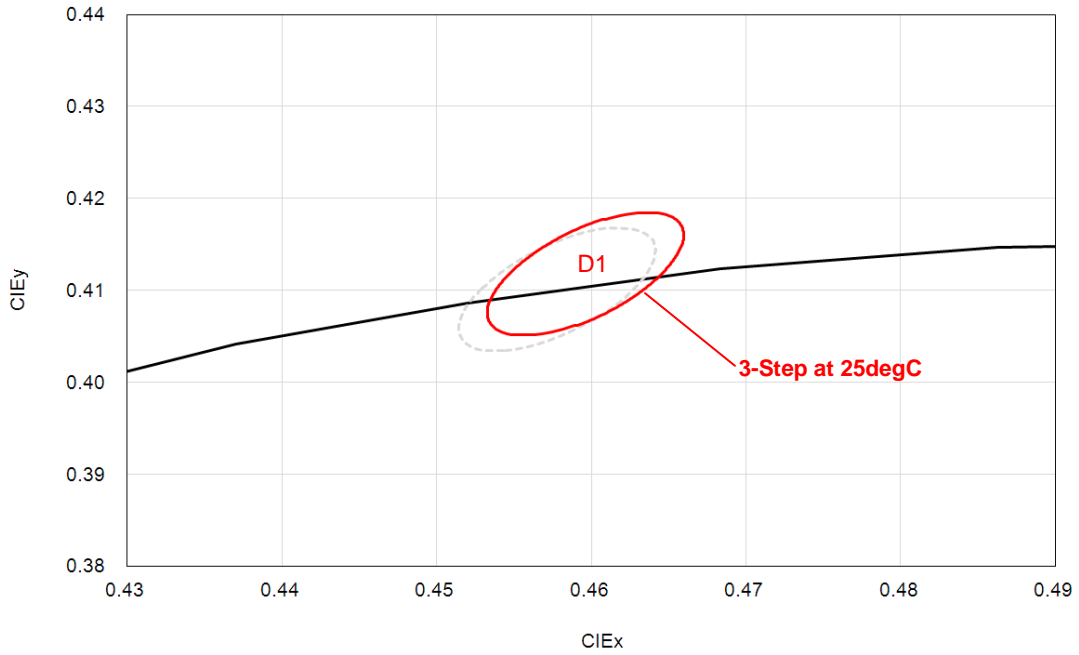

PN: LTPL-M137XXZS27-S1 and LTPL-M137XXZS27-S3

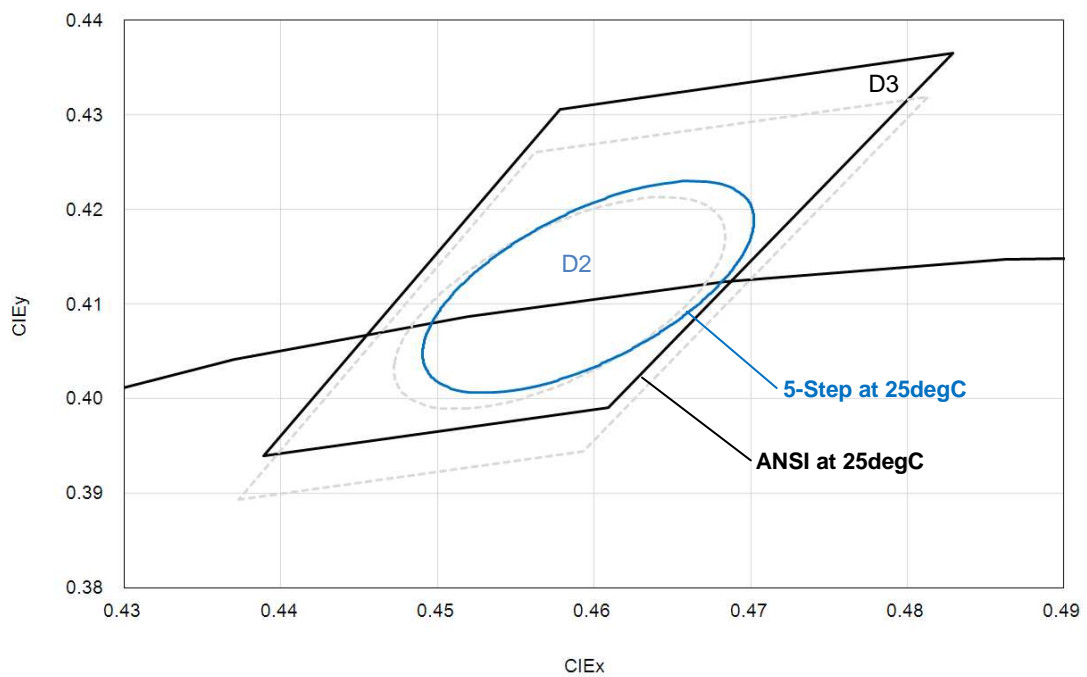

LED HIGH POWER M13 Product Series

■ M13 CRI80 3000K

PN: LTPL-M137XXZS30-T0 and LTPL-M137XXZS30-T2

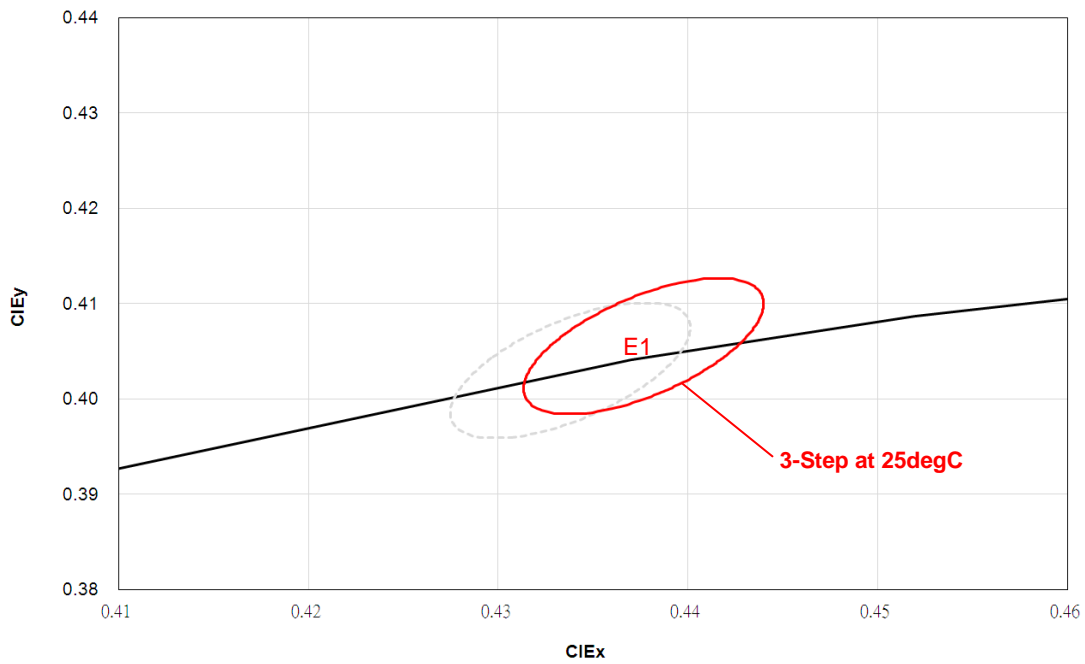

PN: LTPL-M137XXZS30-S1 and LTPL-M137XXZS30-S3

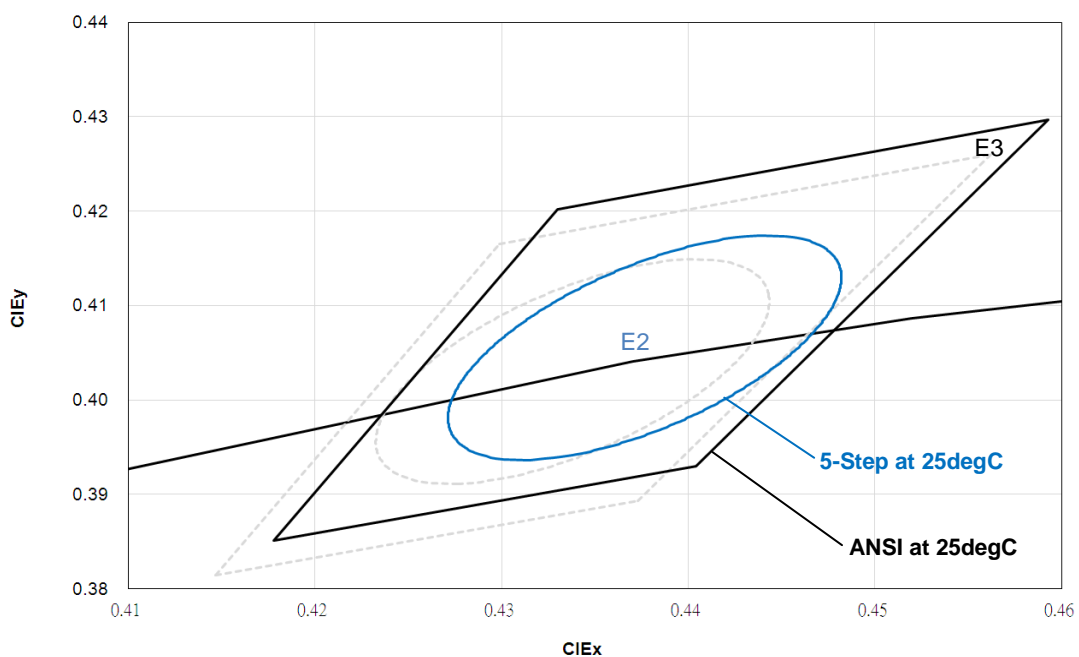

LED HIGH POWER M13 Product Series

■ M13 CRI80 4000K

PN: LTPL-M137XXZS40-T0 and LTPL-M137XXZS40-T2

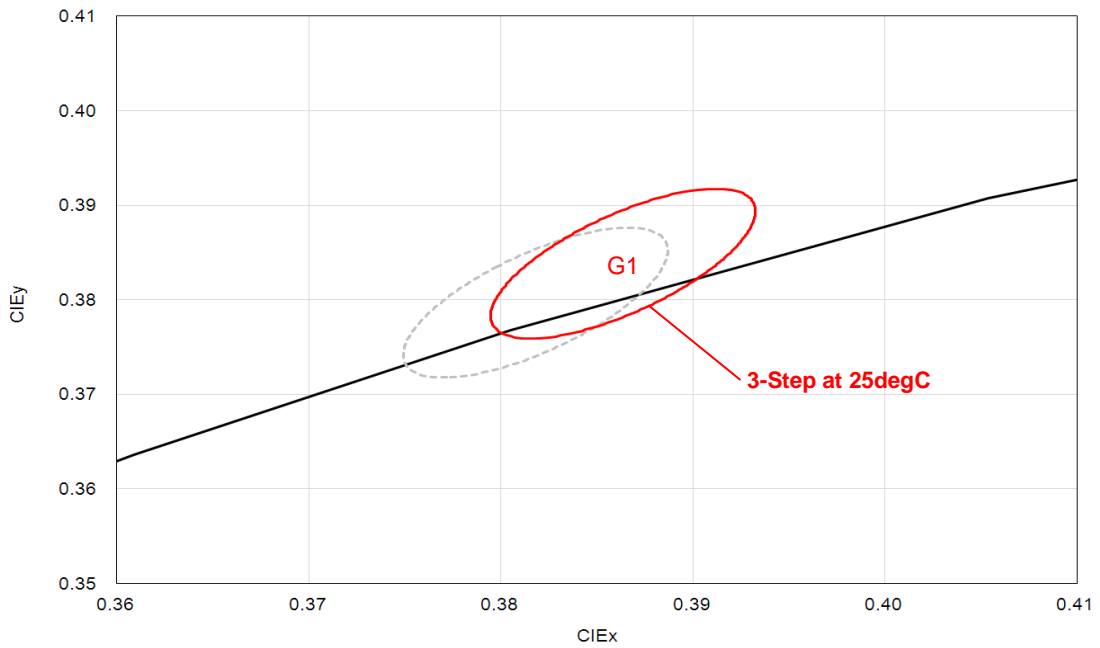

PN: LTPL-M137XXZS40-S1 and LTPL-M137XXZS40-S3

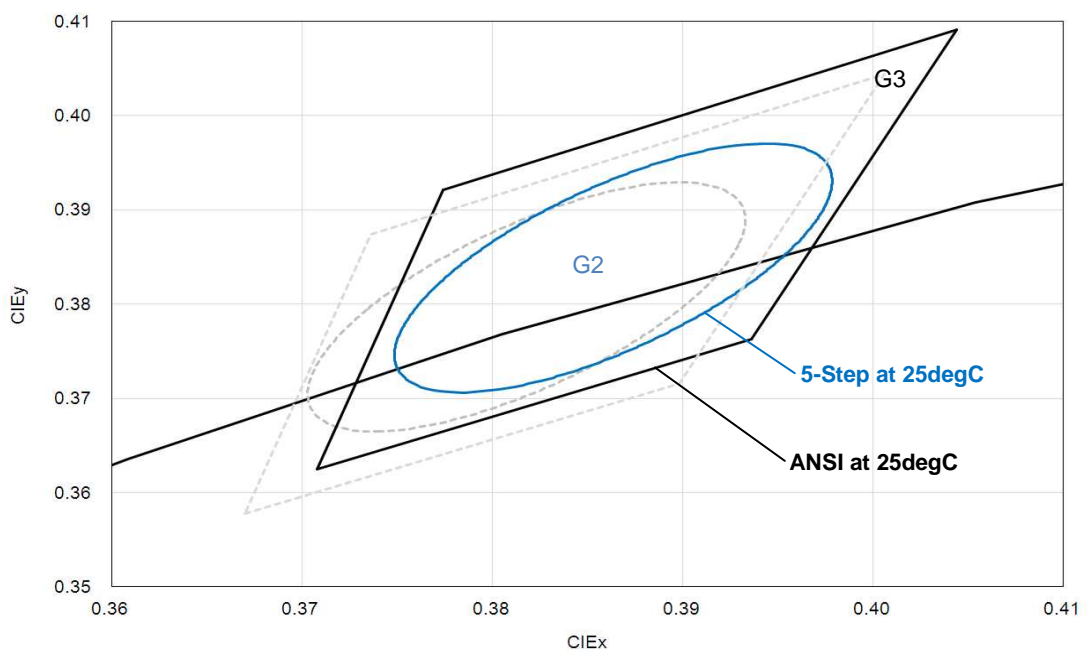

**LED HIGH POWER
M13 Product Series**

■ M13 CRI80 5000K

PN: LTPL-M137XXZS50-F1 and LTPL-M137XXZS50-F3

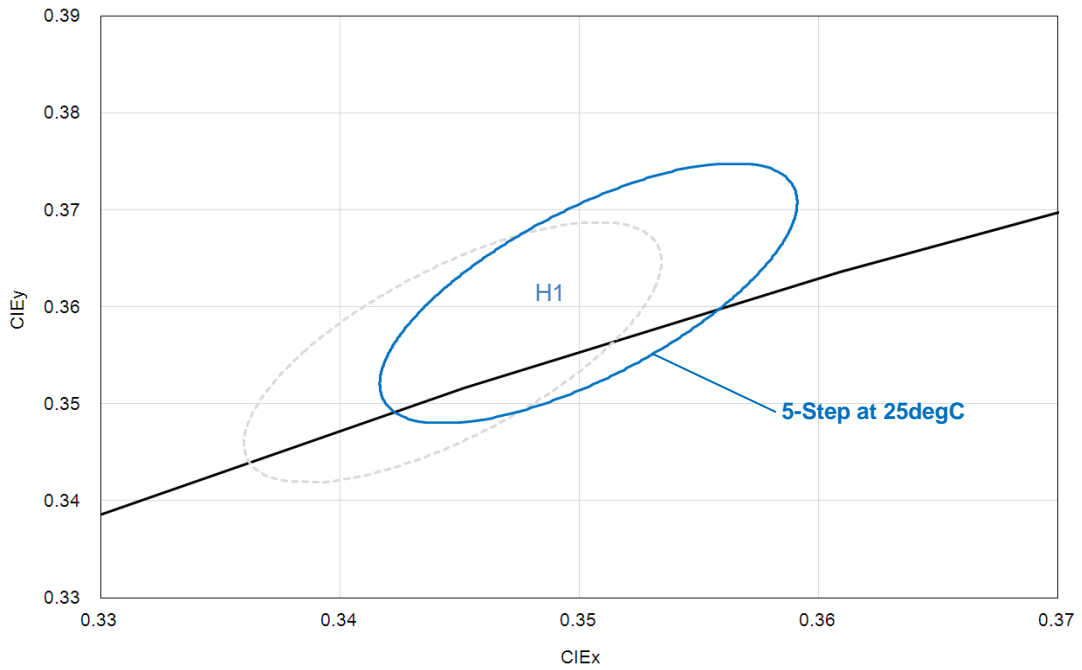

PN: LTPL-M137XXZS50-S1 and LTPL-M137XXZS50-S3

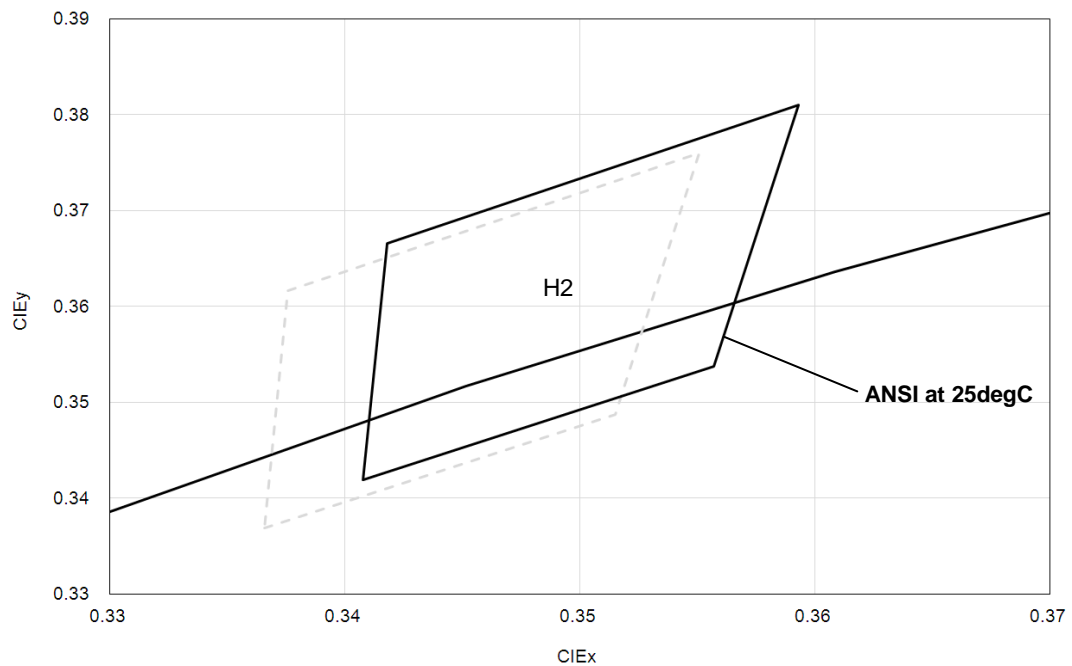

**LED HIGH POWER
M13 Product Series**

■ M13 CRI80 5700K

PN: LTPL-M137XXZS57-F1 and LTPL-M137XXZS57-F3

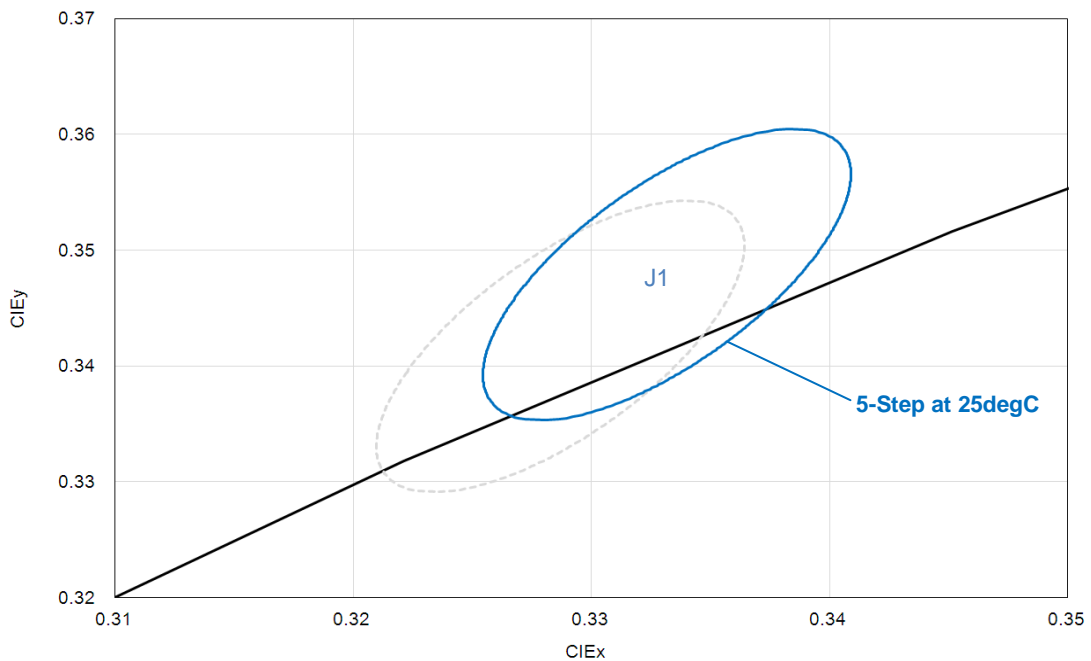

PN: LTPL-M137XXZS57-S1 and LTPL-M137XXZS57-S3

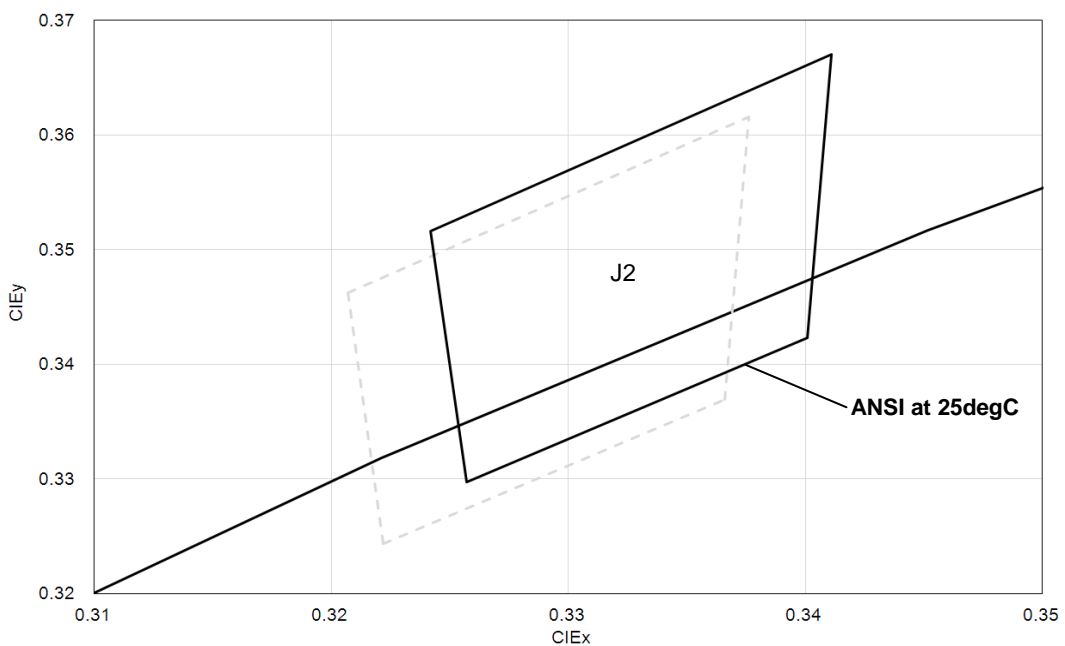

LED HIGH POWER M13 Product Series

6. Reliability Test Plan

No	Test item	Condition	Duration	Number of Failed	Result
1	High Temperature Operating Life	$T_c=85^{\circ}\text{C}$, I_F =Typical Current	1K hours	0/10	Pass
2	Wet High Temperature Operating Life	$60^{\circ}\text{C}/90\%\text{RH}$, I_F =Typical Current(DC) 30 mins ON/OFF	1K hours	0/10	Pass
3	Thermal Shock	-40°C to 125°C , 15minutes dwell, <10 seconds transfer, measurement in every 250 cycles	500 cycles	0/10	Pass
4	Fast Switch Cycling Test	40000cycles, 2 mins On/Off, Room temperature($25^{\circ}\text{C}\pm 5^{\circ}\text{C}$), measurement in every 5000 cycles	40K cycles	0/10	Pass
5	High Temperature Storage Life	$T_a=120^{\circ}\text{C}$	1K hours	0/10	Pass
6	Low Temperature Storage Life	$T_a=-55^{\circ}\text{C}$	1K hours	0/10	Pass
7	Mechanical Shock	1500G, 0.5ms pulse, 5 shocks each 6 axis	30 Times (5 shocks each 6 axis)	0/10	Pass
8	Variable Vibration Frequency	10-2000-10 Hz, log or linear sweep rate, 20G for approximately minute 1.5mm, each applied three times per axis over 6 hrs.	18 hrs (3 times per axis over 6 hrs)	0/10	Pass

■ Criteria for Judging the Damage

Item	Symbol	Test Condition	Criteria for Judgment	
			Min.	Max.
Forward Voltage	V_F	I_F =Typical Current		U.S.L. x 1.1
Luminous Flux	Lm	I_F =Typical Current	L.S.L. x 0.7	
CCX & CCY	X,Y	I_F =Typical Current		Shift<0.02

Notes:

1. Operating life tests are mounted on thermal heat sink
2. Storage items are only component, not put on heat sink.

LED HIGH POWER M13 Product Series

7. Packing Specifications

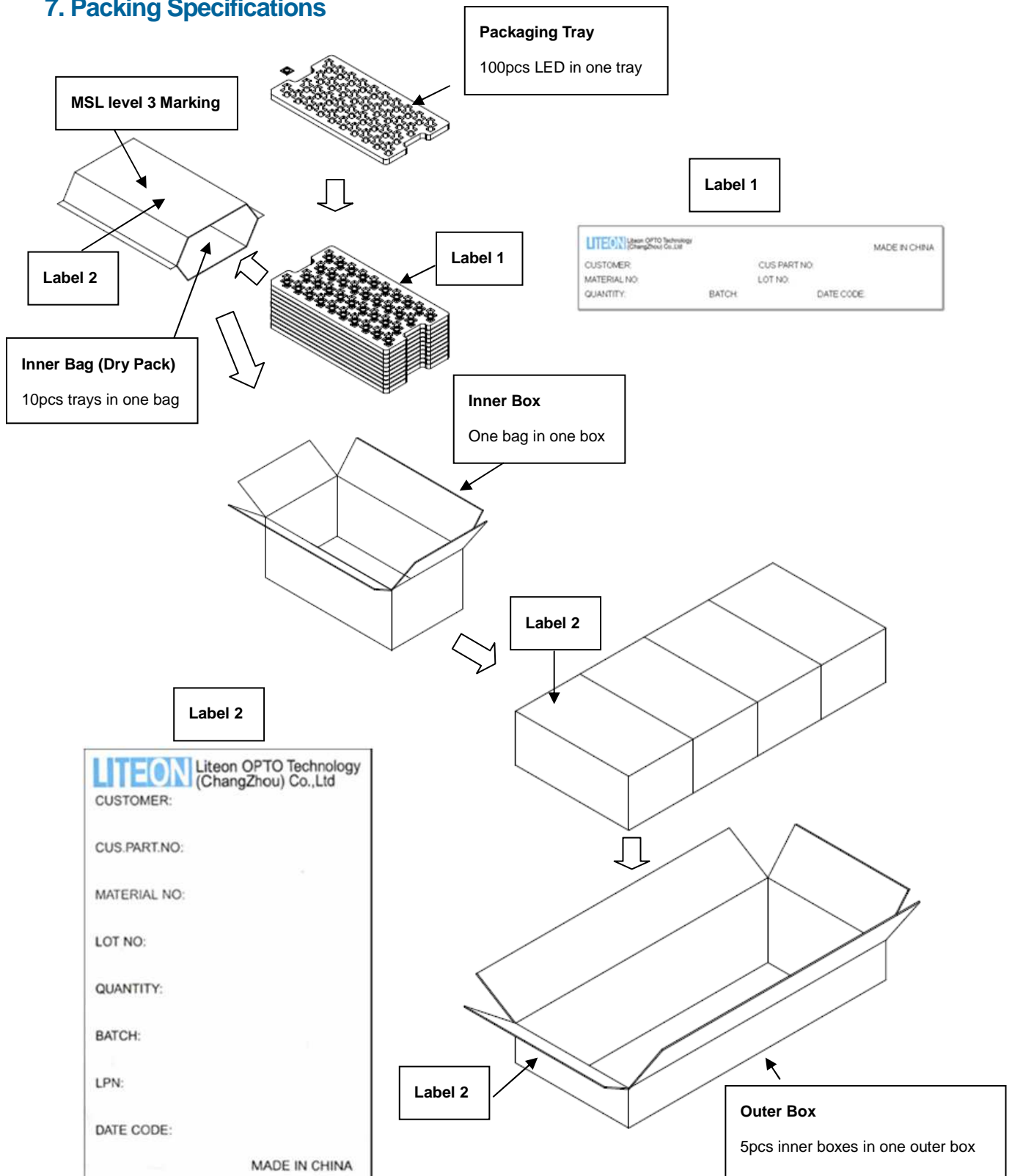

LED HIGH POWER M13 Product Series

8. Cautions

8.1 An LED is a current-operated device. In order to ensure intensity uniformity on multiple LEDs connected in parallel in an application, it is recommended that a current limiting resistor be incorporated in the drive circuit, in series with each LED as shown in circuit below.

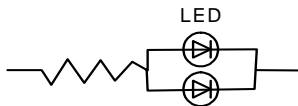

(A) Recommended circuit.

(B) The brightness of each LED might appear different due to the differences in the I-V characteristics of those LEDs.

8.2 Do not put any pressure on the light emitting surface either by finger or any hand tool and do not stack the COB products. Stress or pressure may cause damage to the wires of the LED array.

8.3 This product is not designed for the use under any of the following conditions, please confirm the performance and reliability are well enough if you use it under any of the following conditions

- Do not use sulfur-containing materials in commercial products including the materials such as seals and adhesives that may contain sulfur.
- Do not put this product in a place with a lot of moisture (over 85% relative humidity), dew condensation, briny air, and corrosive gas (Cl, H₂S, NH₃, SO₂, NO_x, etc.), exposure to a corrosive environment may affect silver plating.

ESD (Electrostatic Discharge)

Static Electricity or power surge will damage the LED. Suggestions to prevent ESD damage:

- Use of a conductive wrist band or anti-electrostatic glove when handling these LEDs.
- All devices, equipment, and machinery must be properly grounded.
- Work tables, storage racks, etc. should be properly grounded.
- Use ion blower to neutralize the static charge which might have built up on surface of the LED's plastic lens as a result of friction between LEDs during storage and handling.

ESD-damaged LEDs will exhibit abnormal characteristics such as high reverse leakage current, low forward voltage, or “no light up” at low currents.

To verify for ESD damage, check for “light up” and V_F of the suspect LEDs at low currents.

X-ON Electronics

Largest Supplier of Electrical and Electronic Components

Click to view similar products for [High Power LEDs - White category](#):

Click to view products by [Lite-On manufacturer](#):

Other Similar products are found below :

[G42180-08](#) [B42180-08](#) [STW8Q2PA-R5-HA](#) [SZ5-M1-W0-00-V3/W2-AA](#) [LTPL-P00DWS57](#) [LZP-D0WW00-0000](#) [CLM-9-30-90-36-AC32-F4-3](#) [SZ5-M1-WW-C8-V1/V3-FA](#) [BXRC-27E2000-D-73](#) [BXRC-27G2000-D-73](#) [BXRC-30E1000-D-73](#) [BXRC-30G2000-D-73](#) [BXRC-40E1000-D-73](#) [BXRE-30G2000-B-73](#) [BXRE-30G2000-C-73](#) [BXRE-50C2001-C-74](#) [CXM-22-27-80-54-AC30-F4-3](#) [XHP50B-00-0000-0D0UH245G](#) [XHP50B-00-0000-0D0UH240G](#) [XHP50B-00-0000-0D0UG227H](#) [XHP50B-00-0000-0D0HJ245G](#) [MP-5050-8100-27-80](#) [MP-5050-6100-65-80](#) [MP-5050-6100-50-80](#) [MP-5050-6100-40-80](#) [MP-5050-6100-30-80](#) [CXM-22-30-80-54-AC30-F4-3](#) [LTW-2835SZK57](#) [BXEM-50C0000-0-000](#) [WW-WNA30TS-U1\(M1\)](#) [KW CSLPM2.CC-8L8M-4L8N](#) [KW CSLPM2.CC-8L8M-4O9Q](#) [KW DPLS32.SB-6H6J-E5P7-EG-Z264](#) [L1V1-507003V500000](#) [CXM-22-35-80-36-AC10-F3-3](#) [KW3 CGLNM1.TG-Z6QF6-EBVFFCBB46-DFGA](#) [JB5630AWT-H-H65EA0000-NZ000001](#) [XHP50B-00-0000-0D0UG430H](#) [CXM-22-35-90-54-AC40-F5-3](#) [CXM-22-35-80-54-AC40-F5-3](#) [OSM51206E1N-0.8T](#) [OSW43020C1C](#) [MP161611032290](#) [MP-1616-2103-50-90](#) [KW CULPM1.TG-Z6RF7-ebvFfcbB46-65G5](#) [KW DMLS33.SG-Z6M7-EBVFFCBB46-8E8G-700-S](#) [XPGDWT-B1-0000-00EEA](#) [XHP70B-00-0000-0D0BP450E](#) [KW DMLN33.SG-7J7K-EBVFFCBB46-8E8G-200-S](#) [ASMT-MW05-NMNS1](#)