

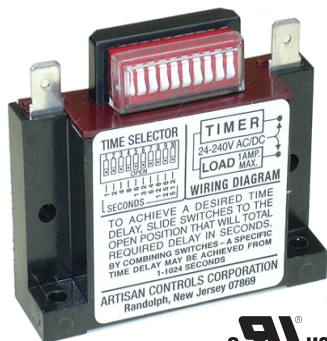

# Solid State Timers and Controllers

## 438USA

### Universal Switch Adjustable Time Capsule®



The Model 438USA is the most popular of all Artisan Controls Corporation Time Capsule® devices. By merely connecting the two terminals in series with any load circuit drawing between ten milliamperes and one ampere operating from any voltage between 19 volts and 288 volts AC or DC, the 438USA turns that load circuit into a delay on make timing circuit. Set the 10 DIP switches to the required delay, and apply operating voltage. When the operating voltage is applied, a small amount of current will flow through the load and the timer (leakage current). At the end of the delay period, the model 438USA turns ON and full load current is permitted to flow

#### Mechanical & Wiring

#### Timing Diagram

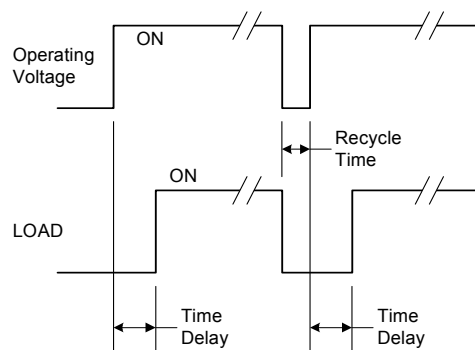
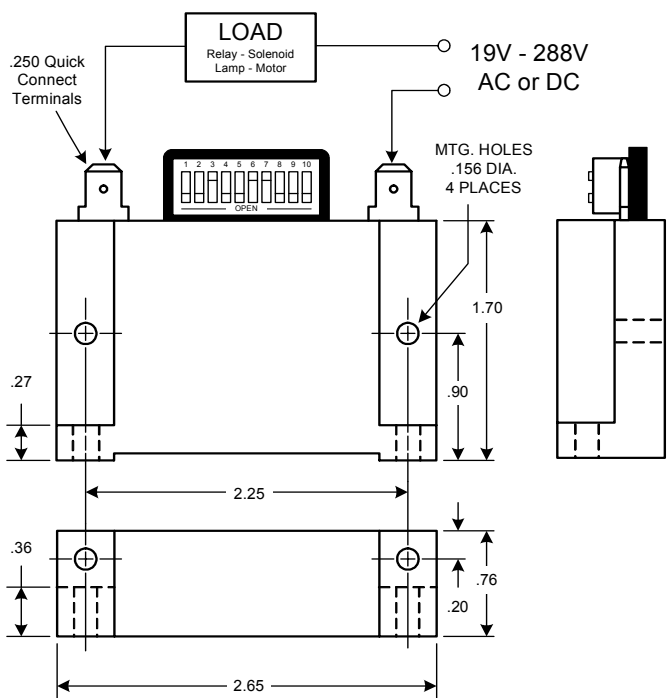

#### Setting the DIP Switches

The DIP switches are used to set the time delay period between 1 and 1024 seconds. The timer has an internal 1 second delay, opening of the DIP switches adds their corresponding value to that internal delay. The switches to the right are all opened for a total delay of 1023 seconds, adding that to the internal 1 second provides the full 1024 seconds. Any time delay from 1 to 1024 seconds can be achieved by opening the appropriate switches

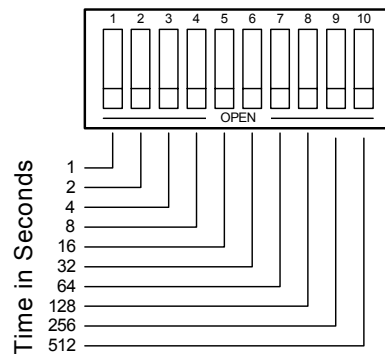

VISIT OUR WEB SITE AT: [www.artisancontrols.com](http://www.artisancontrols.com)

**Notice:** Artisan Controls Corporation assumes no responsibility for customers applications or product design. The information and data contained herein is the sole and exclusive property of Artisan Controls Corporation. Any duplication, misuse, or conversion of this information without the express written consent of Artisan Controls Corporation is illegal and will result in damages including court costs and attorney fees being assessed against the party misusing this property

**Tel: 973-598-9400 • Fax: 973-598-9410 • Toll Free: 800-457-4950**  
 Artisan Controls Corporation, 111 Canfield Ave, Bldg B15-18, Randolph, New Jersey 07869, USA



## *Solid State Timers and Controllers*

### Specifications .....

**Operating Voltage:** 19 to 288 Volts AC 50/60 Hz or DC.

**Timing Mode:** Delay-On-Make, External load energizes after preset timing period as set by the 10 DIP switches.

**Timing Range:** Digital timing is DIP switch programmable from 1 to 1024 seconds.

**Timing Adjustment:** From 1 second (All Closed) to 1024 seconds (All Open) in 1 second increments.

**Programmable Timing Tolerance:**  $\pm 10\%$

**Timing Variation:**  $\pm 15\%$  worst case at any combination of operating voltage and temperature.

**Repeatability Of Timing Period:**  $\pm 1\%$  nominal.

**Recycle Time:** 50 milliseconds if output is ON, 200 milliseconds during a timing cycle while output is OFF.

**Output Rating:** 10 milliamperes to 1 ampere inductive with inrush current to 25 amperes for 8 milliseconds.

**Output Voltage Drop in "ON" State:** 4 volts maximum.

**Leakage Current in "OFF" State:** 0.6 mA @ 24V, 1.8 mA @ 48V, 5.4 mA @ 120V, 11.4 mA @ 240V.

**Transient Protection:** Maximum transient voltage protection is 6000 volts as delivered through a source resistance of 30 ohms with a maximum duration of 8.3 milliseconds.

**Operating Temperature:**  $-20^{\circ}\text{C}$  to  $+85^{\circ}\text{C}$

**Humidity:** 95% condensing

**Terminations:** Two (2) .25 Faston type.

**Agency Certifications:** UL File E47858, Appliance Controls - Component ATNZ2 (US) & ATNZ8 (Can), Auxiliary Devices - Component NKCR2 (US) & NKCR8 (Can).

**National Stock Number:** NSN 5999-01-113-0824

**Data Sheet Revision Date:** January 3, 2006

VISIT OUR WEBSITE AT: [www.artisancontrols.com](http://www.artisancontrols.com)

**Notice:** Artisan Controls Corporation assumes no responsibility for customers applications or product design. The information and data contained herein is the sole and exclusive property of Artisan Controls Corporation. Any duplication, misuse, or conversion of this information without the express written consent of Artisan Controls Corporation is illegal and will result in damages including court costs and attorney fees being assessed against the party misusing this property

**Tel: 973-598-9400 • Fax: 973-598-9410 • Toll Free: 800-457-4950**  
Artisan Controls Corporation, 111 Canfield Ave, Bldg B15-18, Randolph, New Jersey 07869, USA

## **X-ON Electronics**

Largest Supplier of Electrical and Electronic Components

*Click to view similar products for [artisan controls manufacturer](#):*

Other Similar products are found below :

[2600SA-8](#) [438A-115-1](#) [4970-2](#) [423-24-60FPM](#) [437-110-1A](#) [4210-115-60FPM](#) [438USAS](#) [438USA](#) [438U](#)