

SPECIFICATION FOR APPROVAL

承 認 書

Description : Electret Condenser Microphone

Kingstate Part No. : KECG2740PBJ

Customer's Model No. : _____

Specification No. : MKD-1318

Number Of The Edition : 1.1

CUSTOMER'S APPROVED SIGNATURE		



志豐電子股份有限公司 KINGSTATE ELECTRONICS CORP.

Address: 10F, No. 69-11, Sec. 2, Chung Cheng E. Rd., Tamshui County, Taipei Hsien, Taiwan, R.O.C.

International sales dept.: TEL:886-2-2809-5651 FAX:886-2-2809-7151

Domestic sales dept.: TEL:886-2-2809-0668 FAX:886-2-28096748

<http://www.kingstate.com.tw>

Approved by	Checked by	Issued by
		 12/10/04'

A. SCOPE 範疇

This specification applies electret condenser microphone, **KECG2740PBJ**

此規格書適用於電容式麥克風 **KECG2740PBJ**

B. SPECIFICATION 規格

No.	Item	Symbol	Unit	Specification	Condition
1	Directivity 方向性			Omnidirectional 全指向	
2	Sensitivity 靈敏度	S	dB	-40 ± 3	f=1KHz, 1Pa 0dB=1V/Pa
3	Standard operating voltage 標準操作電壓	Vs	V D.C.	2	
4	Output impedance 輸出阻抗	Zout	KΩ	2.2	f=1KHZ, 1Pa
5	Max operating voltage 最大操作電壓		V D.C.	10	
6	Sensitivity reduction 減電壓靈敏度	$\Delta S-Vs$	dB	-3	f=1KHz, 1Pa Vs=2.0V D.C. to 1.5V D.C.
7	Frequency 頻率	f	Hz	20 ~ 20,000	
8	Max. current consumption 最大耗電流	IDSS	mA	0.5	Vs=2.0V D.C. RL=2.2KΩ
9	Signal to noise ration 訊號對雜音比	S/N	dBA	56	f=1KHz, 1Pa A weighted
10	Operation temp. 操作溫度		°C	-20 ~ +70	
11	Storage temp. 儲存溫度		°C	-20 ~ +70	
12	Dimension 尺寸		mm	φ 6 x 2.7	See appearance drawing 請參照外觀尺寸圖
13	Weight (MAX) 重量		gram	0.3	
14	Material 材質			AL 鋁	
15	Terminal 端子			Pin type	See appearance drawing 請參照外觀尺寸圖
16	Environmental Protection Regulation 環保法規			ROHS	

We use "Pascal (Pa)" indication of sensitivity as per the recommendation of I.E.C. (International Electro technical Commission). The Sensitivity of "Pa" will increase 20dB comparing with "ubar" indication.

Example: -60dB (0dB=1V/ubar) = -40dB (1V/Pa)

依I.E.C.(國際電子協會)建議,以"Pa"為靈敏度標示單位比"ubar" 靈敏度標示單位增加20dB

例如: -60dB (0dB=1V/ubar) = -40dB (1V/Pa)

C. TYPICAL FREQUENCY RESPONSE CURVE 頻率響應曲線

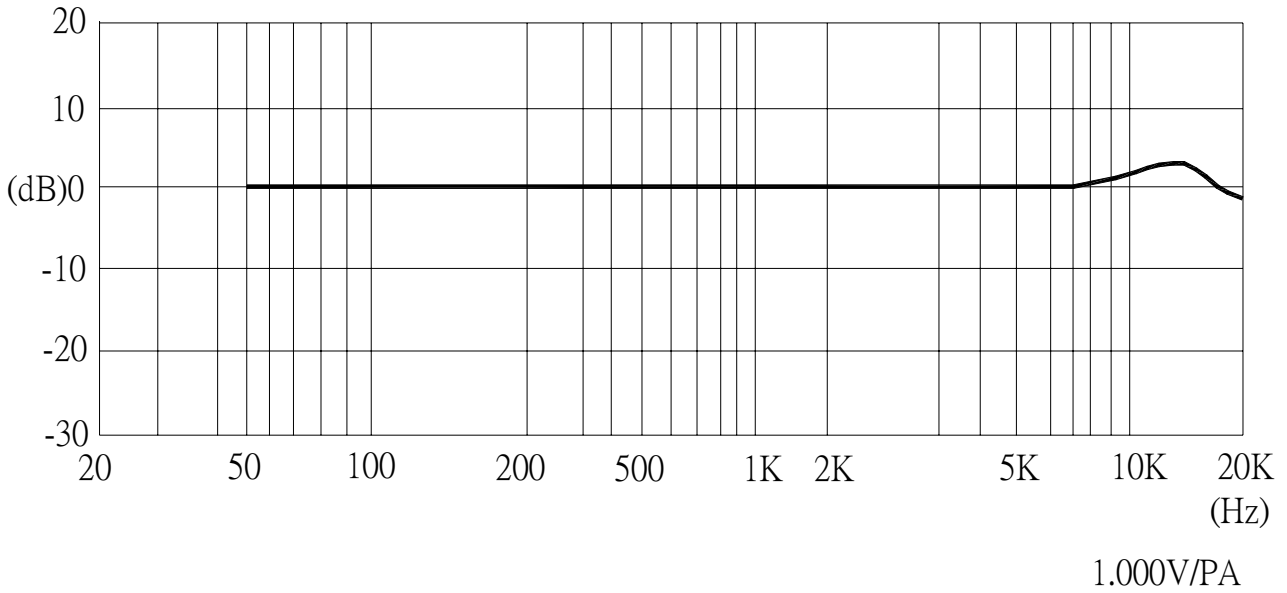

D. APPEARANCE DRAWING

外觀尺寸圖

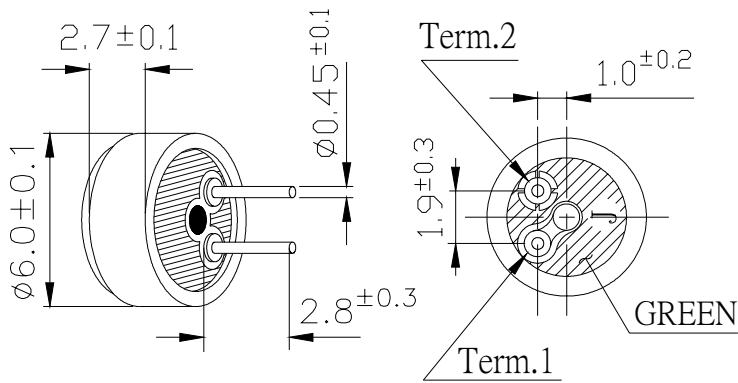

Unit:mm

E. MEASUREMENT CIRCUIT

測量線路

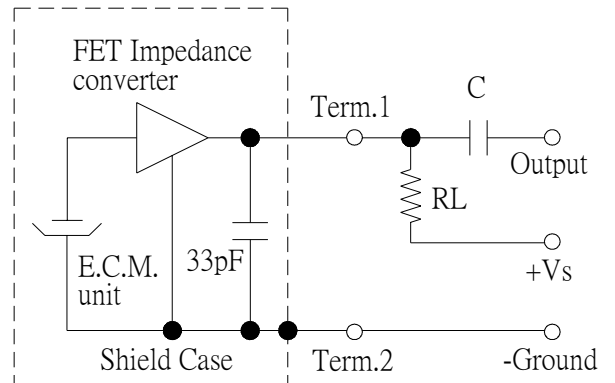

Schematic Diagram

RL=2.2KΩ

F. MECHANICAL CHARACTERISTICS 機械特性

No.	Item	Test condition	Evaluation standard
1	Soldering Heat Resistance 焊錫耐熱性	Lead terminal are immersed in soldering bath of $+280\pm 5^{\circ}\text{C}$ for 3 ± 1 second. 端子部份浸入以 $+280\pm 5^{\circ}\text{C}$ 焊錫槽中 3 ± 1 秒	No interference in operation 操作無任何不良
2	Solderability 焊錫附著性	Lead terminal are immersed in rosin for 5 seconds and then immersed in solder bath of $+280\pm 5^{\circ}\text{C}$ for 3 ± 1 second. 端子部份浸入松香溶液 5 秒後, 再浸入 $+280\pm 5^{\circ}\text{C}$ 溶融焊錫槽中 3 ± 1 秒.	90% min. lead terminals shall be wet with solder. 浸入端子部份附著焊錫 90%以上.
3	Terminal Mechanical Strength 端子強度	Apply the terminal with 0.5KG strength for 1 minute. 對端子施以 0.5KG 拉力 1 分鐘後	No damage and cutting off 端子不鬆動, 不脫落
4	Vibration Test 振動測試	The part shall be measured after being applied vibration of amplitude of 1.5mm with 10 to 55hz band of vibration frequency to each of 3 per-pendicular directions for 2 hours. 振動週波數 10~55HZ、全振幅 1.5mm 於 X.Y.Z 3 個方向, 各 2 小時	After any tests, the sensitivity to be within $\pm 3\text{dB}$ 測試其靈敏度須與原測試值的差異不超過 ± 3 dB.
5	Drop Test 落下測試	The part unit without packaged must be subjected to each 3 drops at three axes from the height of 1 meter to 20 mm thick wooden board. 未包裝麥克風單體從 1 公尺高處, X.Y.Z.3 個方向, 各 3 回, 落於 20mm 厚木板上.	

G. ENVIRONMENTAL TEST 環境試驗

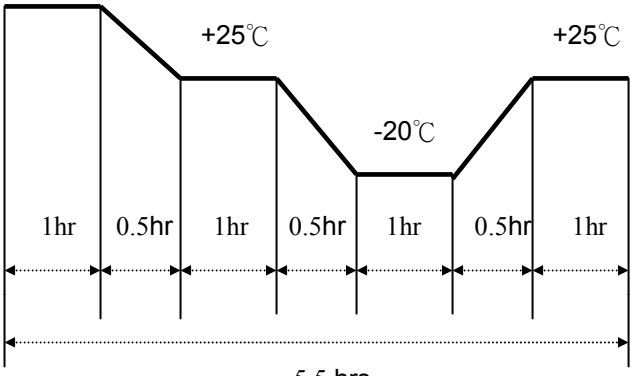
No.	Item	Test conditions	Evaluation standard
1	High temp. test 高溫測試	After being placed in a chamber at $+70^{\circ}\text{C}$ for 72 hours. 置於 $+70^{\circ}\text{C}$ 環境中 72 小時	After any tests, the sensitivity to be within $\pm 3\text{dB}$ of initial sensitivity after 6 hours of conditioning at $+25^{\circ}\text{C}$ 經測試後麥克風, 須靜置於 $+25^{\circ}\text{C}$ (室溫) 環境中 6 小時後. 測試其靈敏度須與原測試值的差異不超過 ± 3 dB
2	Low temp. test 低溫測試	After being placed in a chamber at -20°C for 72 hours. 置於 -20°C 環境中 72 小時	
3	Humidity test 相對濕度測試	After being placed in a chamber at $+40^{\circ}\text{C}$ and $90\pm 5\%$ relative humidity for 240 hours. 置於 $+40^{\circ}\text{C}$, 相對濕度 $90\pm 5\%$ 環境中 240 小時	
4	Temp. cycle test 溫度循環測試	The part shall be subjected to 10 cycles. One cycle shall be consist of: 單體承受溫度循環測試 10 次, 其循環內容如圖示: 	

TEST CONDITION.

Standard Test Condition : a) Temperature : $+5 \sim +35^{\circ}\text{C}$ b) Humidity : 45-85% c) Pressure : 860-1060mbar
 一般測試條件 : a) 溫度 : $+5 \sim +35^{\circ}\text{C}$ b) 濕度 : 45-85% c) 氣壓 : 860-1060mbar
 Judgement Test Condition : a) Temperature : $+25 \pm 2^{\circ}\text{C}$ b) Humidity : 60-70% c) Pressure : 860-1060mbar
 爭議時測試條件 : a) 溫度 : $+25 \pm 2^{\circ}\text{C}$ b) 濕度 : 60-70% c) 氣壓 : 860-1060mbar

H. PACKING STANDARD 包裝規格

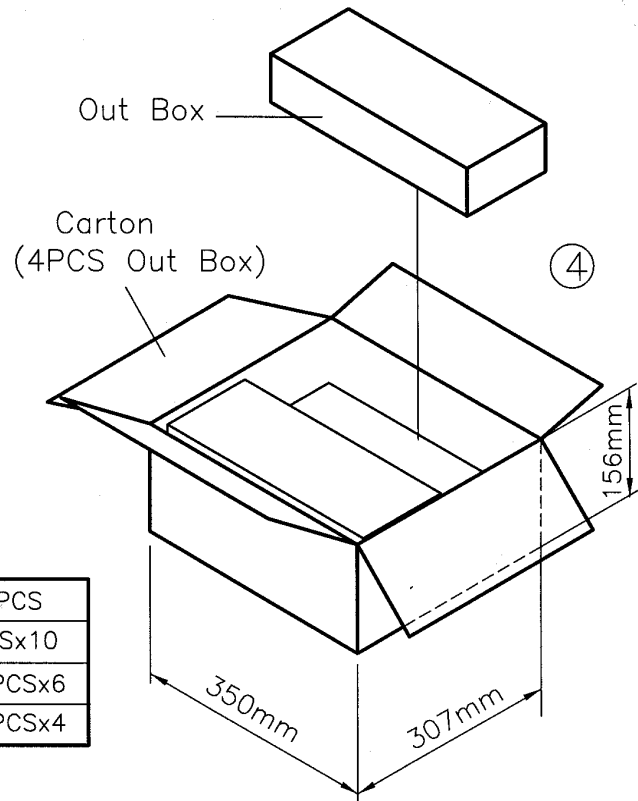
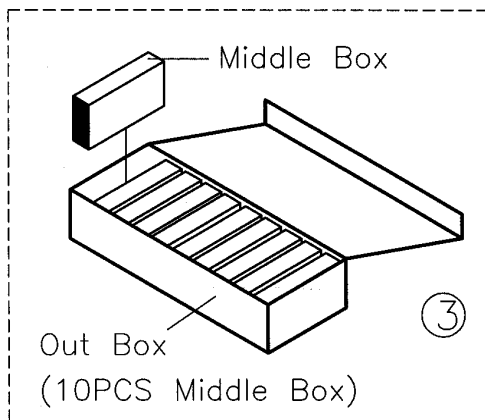
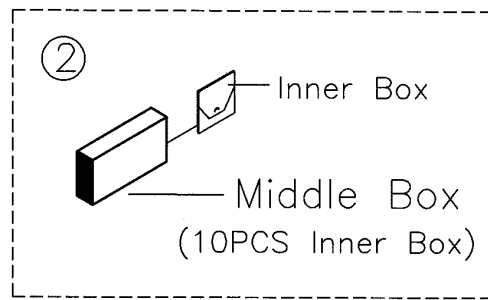
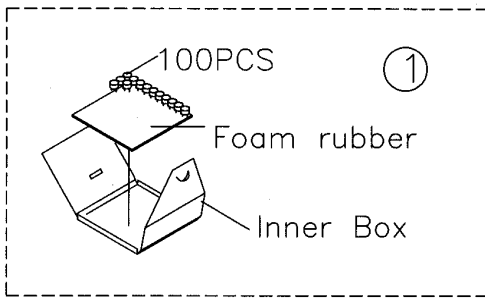

Inner Box	63mmx63mmx8mm	1x100PCS
Middle Box	126mmx63mmx48mm	100PCSx10
Out Box	330mmx130mmx70mm	1,000PCSx6
Carton Box	350mmx310mmx160mm	6,000PCSx4

X-ON Electronics

Largest Supplier of Electrical and Electronic Components

Click to view similar products for [kingstate](#) manufacturer:

Other Similar products are found below :

[KPEG352](#) [KXG1205](#) [KPEG130](#) [KMTG1261](#) [KSSG1201-16](#) [KPEG260H](#) [KDMG36008](#) [KPEG1600](#) [KPEG-202](#) [KDMG36008-10B](#) [KPEG-653SAN](#) [KPEG420](#) [KPEG623AN](#) [KPEG1501](#) [KPEG-353](#) [KPEG260](#) [KPEG270](#) [KDMG13008L-02](#) [KPEG228](#) [KSSG3108](#) [KPEG280](#) [KPEG222](#) [KECG2740PBJ](#) [KCVG084B16](#) [KPEG006](#) [KEIG4537TFL-N](#) [KPEG214A](#) [KPEG153](#) [KMTG1102-A1](#) [KPEG960](#) [KPEG203](#) [KPEG106-HS](#) [KMTG1303-1](#) [KPEG165](#) [KTG1212](#) [KEEG1542PBL-A](#) [KPEG242](#) [KSSG33J12](#) [KPEG163](#)