

CRYSTAL OSCILLATOR SPXO

SG-310 series

- Frequency range : 2 MHz to 80 MHz
- Supply voltage : 1.8 V Typ. / 2.5 V Typ. / 3.3 V Typ.
- Current consumption : 1.5 mA Typ.
(SEF 1.8 V No load condition 48 MHz)
- Function : Standby(\overline{ST})
- External dimensions : 3.2 × 2.5 × 1.05 t (mm) Typ.



Product Number (please contact us)
Q33310xx0xxxx00



Actual size

Specifications (characteristics)

Item	Symbol	Specifications					Remarks
		SG-310 SEF	SG-310 SDF	SG-310 SCF	SG-310 SDN	SG-310 SCN	
Output frequency range	f_0	2,000 MHz to 48,000 MHz			3,000 MHz to 80,000 MHz		
Supply voltage	V_{CC}	1.8 V Typ. 1.6 V to 2.2 V	2.5 V Typ. 2.2 V to 3.0 V	3.3 V Typ. 2.7 V to 3.6 V	2.5 V Typ. 2.2 V to 2.7 V	3.3 V Typ. 2.7 V to 3.6 V	
Temperature range	Storage temperature	-40 °C to +125 °C					Store as bare product after unpacking
	Operating temperature	-40 °C to +85 °C					
Frequency tolerance	f_{tol}	B: $\pm 50 \times 10^{-6}$, C: $\pm 100 \times 10^{-6}$			B: $\pm 50 \times 10^{-6}$, C: $\pm 100 \times 10^{-6}$		-20 °C to +70 °C
		M: $\pm 100 \times 10^{-6}$			M: $\pm 100 \times 10^{-6}$		-40 °C to +85 °C
		-			D: $\pm 20 \times 10^{-6}$, S: $\pm 25 \times 10^{-6}$		-20 °C to +70 °C
		-			R: $\pm 25 \times 10^{-6}$		-30 °C to +85 °C
		-			P: $\pm 20 \times 10^{-6}$		-30 °C to +85 °C
Current consumption	I_{CC}	1.5 mA Max.	1.5 mA Max.	1.5 mA Max.	4.0 mA Max.	5.0 mA Max.	No load condition, 2 MHz $\leq f_0 \leq$ 4 MHz
		1.5 mA Max.	1.5 mA Max.	2.0 mA Max.			No load condition, 4 MHz $\leq f_0 \leq$ 8 MHz
		1.5 mA Max.	2.0 mA Max.	2.5 mA Max.			No load condition, 8 MHz $\leq f_0 \leq$ 16 MHz
		2.0 mA Max.	2.0 mA Max.	2.5 mA Max.			No load condition, 16 MHz $\leq f_0 \leq$ 25 MHz
		2.0 mA Max.	2.5 mA Max.	3.5 mA Max.			No load condition, 25 MHz $\leq f_0 \leq$ 33 MHz
		3.0 mA Max.	3.5 mA Max.	4.5 mA Max.			No load condition, 33 MHz $\leq f_0 \leq$ 48 MHz
Stand-by current	I_{std}	0.7 μ A Max. (0.2 μ A Typ.)	1.5 μ A Max. (0.5 μ A Typ.)	2.0 μ A Max. (1.0 μ A Typ.)	6.0 mA Max.	7.0 mA Max.	No load condition, 48 MHz $\leq f_0 \leq$ 80 MHz
Symmetry	SYM	45 % to 55 %	45 % to 55 %	45 % to 55 %	45 % to 55 %		2 MHz $\leq f_0 \leq$ 16 MHz
		40 % to 60 %	40 % to 60 %	40 % to 60 %			16 MHz $\leq f_0 \leq$ 40 MHz
High output voltage	V_{OH}	90 % V_{CC} Min.					$I_{OH} = -3$ mA
Low output voltage	V_{OL}	10 % V_{CC} Max.					$I_{OL} = 3$ mA
Output load condition (CMOS)	L CMOS	15 pF Max.					
Output enable / disable input voltage	V_{IH}	80 % V_{CC} Min.			70 % V_{CC} Min.		\overline{ST} terminal
	V_{IL}	20 % V_{CC} Max.			30 % V_{CC} Max.		
Rise time / Fall time	t_r / t_f	4 ns Max.					20 % V_{CC} to 80 % V_{CC} level, L CMOS = 15 pF
Start-up time	t_{str}	10 ms Max.			2 ms Max.		t_0 at 90 % V_{CC}
Frequency aging	f_{aging}	$\pm 5 \times 10^{-6}$ / year Max.			$\pm 3 \times 10^{-6}$ / year Max.		+25 °C, First year, $V_{CC} = 1.8$ V, 2.5 V, 3.3 V
		-			$\pm 10 \times 10^{-6}$ Max.		+25 °C, 10 years

External dimensions

(Unit:mm)

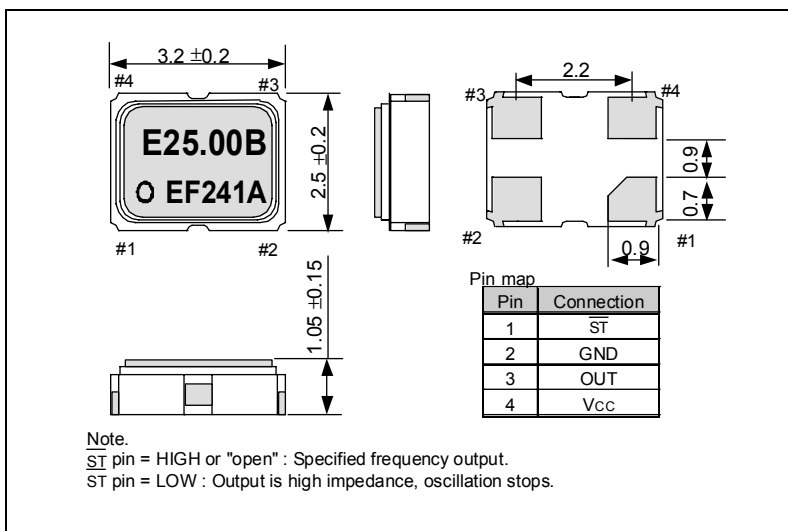

Footprint (Recommended)

(Unit:mm)

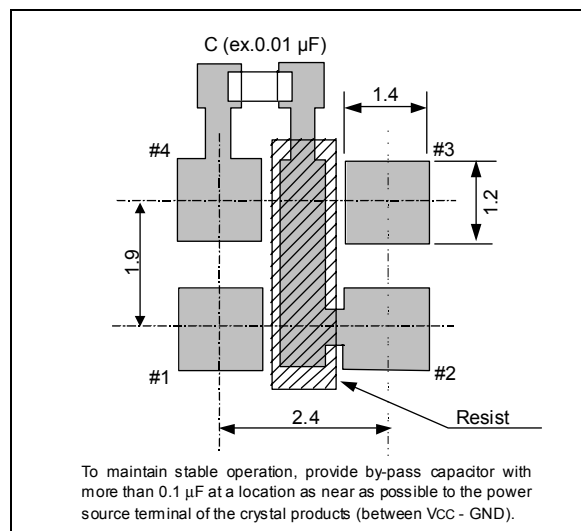

“QMEMS” EPSON TOYOCOM

In order to meet customer needs in a rapidly advancing digital, broadband and ubiquitous society, we are committed to offering products that are one step ahead of the market and a rank above the rest in quality. To achieve our goals, we follow a “3D (three device) strategy” designed to drive both horizontal and vertical growth. We will to grow our three device categories of “Timing Devices”, “Sensing Devices” and “Optical Devices”, and expand vertical growth through a combination of products from these categories.

A Quartz MEMS is any high added value quartz device that exploits the characteristics of quartz crystal material but that is produced using MEMS (micro-electro-mechanical system) processing technology.

Market needs are advancing faster than previously imagined toward smaller, more stable crystal products, but we will stay ahead of the curve by rolling out products that exceed market speed and quality requirements. We want to further accelerate the 3D strategy by QMEMS.

Quartz devices have become crucial in the network environment where products are increasingly intended for broadband, ubiquitous applications and where various types of terminals can transfer information almost immediately via LAN and WAN on a global scale. Epson Toyocom Corporation addresses every single aspect within a network environment. The new corporation offers “Digital Convergence” solutions to problems arising with products for consumer use, such as, core network systems and automotive systems.



PROMOTION OF ENVIRONMENTAL MANAGEMENT SYSTEM CONFORMING TO INTERNATIONAL STANDARDS

At Epson Toyocom, all environmental initiatives operate under the Plan-Do-Check-Action(PDCA) cycle designed to achieve continuous improvements. The environmental management system (EMS) operates under the ISO 14001 environmental management standard.

All of our major manufacturing and non-manufacturing sites, in Japan and overseas, completed the acquisition of ISO 14001 certification.

ISO 14000 is an international standard for environmental management that was established by the International Standards Organization in 1996 against the background of growing concern regarding global warming, destruction of the ozone layer and global deforestation

WORKING FOR HIGH QUALITY

In order to provide high quality and reliable products and services that meet customer needs, Epson Toyocom made early efforts towards obtaining ISO9000 series certification and has acquired ISO9001 for all business establishments in Japan and abroad. We have also acquired ISO/TS 16949 certification that is requested strongly by major automotive manufacturers as standard.

QS-9000 is an enhanced standard for quality assurance systems formulated by leading U.S. automobile manufacturers based on the international ISO 9000 series.

ISO/TS 16949 is a global standard based on QS-9000, a severe standard corresponding to the requirements from the automobile industry.

► Explanation of the mark that are using it for the catalog

	► Pb free.
	► Complies with EU RoHS directive. *About the products without the Pb-free mark. Contains Pb in products exempted by EU RoHS directive. (Contains Pb in sealing glass, high melting temperature type solder or other.)
	► The products have been designed for high reliability applications such as Automotive.

Notice

- This material is subject to change without notice.
- Any part of this material may not be reproduced or duplicated in any form or any means without the written permission of Epson Toyocom.
- The information, applied circuitry, programming, usage, etc., written in this material is intended for reference only. Epson Toyocom does not assume any liability for the occurrence of infringing on any patent or copyright of a third party. This material does not authorize the licensing for any patent or intellectual copyrights.
- Any product described in this material may contain technology or the subject relating to strategic products under the control of the Foreign Exchange and Foreign Trade Law of Japan and may require an export license from the Ministry of International Trade and Industry or other approval from another government agency.
- You are requested not to use the products (and any technical information furnished, if any) for the development and/or manufacture of weapon of mass destruction or for other military purposes. You are also requested that you would not make the products available to any third party who may use the products for such prohibited purposes.
- These products are intended for general use in electronic equipment. When using them in specific applications that require extremely high reliability, such as the applications stated below, you must obtain permission from Epson Toyocom in advance.
/ Space equipment (artificial satellites, rockets, etc.) / Transportation vehicles and related (automobiles, aircraft, trains, vessels, etc.)
/ Medical instruments to sustain life / Submarine transmitters / Power stations and related / Fire work equipment and security equipment
/ traffic control equipment / and others requiring equivalent reliability.
- In this new crystal master for Epson Toyocom, product codes and markings will remain as previously identified prior to the merger.
Due to the on-going strategy of gradual unification of part numbers, please review product codes and markings, as they will change during the course of the coming months.

We apologize for the inconvenience, but we will eventually have a unified part numbering system for Epson Toyocom that will be user friendly.

X-ON Electronics

Largest Supplier of Electrical and Electronic Components

Click to view similar products for [Epson manufacturer](#):

Other Similar products are found below :

[MA-505 24.0000M-C3 ROHS](#) [MC-405 32.7680K-G3: ROHS](#) [S5U13L02P00C100](#) [SG5032CAN 10.000000M-TJGA3](#) [SG-531P 7.3728MC:ROHS](#) [X1G0044810005 SG7050CAN 10 MHZ](#) [SG531P IC Socket for 2520 case](#) [S5U1C31W74T1300](#) [S5U1C17W04T2100 IC Socket for 7050 case](#) [S5U1C17W36T2100](#) [MC-306 32.7680K-E ROHS](#) [MA-505 24.0000M-C0:ROHS](#) [S5U13513P00C100](#) [S5U13781R01C100](#) [SG-210STF 13.5600ML3](#) [SG-210STF 2.0480ML3](#) [Q3851CA000055 XG-1000CA 50 MHZ](#) [EG-2121CA 644.53125MLGPA](#) [SG-636PCE 25.0000MC3:ROHS](#) [MA-506 4.0000M-C3 ROHS](#) [EG-2121CA2000000M-LGPAL3](#) [S5U13U00P00C100](#) [S5U13513R00C100](#) [S5U13517P00C200](#) [FA-238 16.0000MB50X-A3](#) [S5U13748P00C100](#) [S5U1C17W18T2100 IC Socket for 5032 case](#) [SG-210STF 8.0000ML](#) [Q325310110003 SG-531P 10 MHZ C](#) [MA-506 25.0000M-C3:ROHS](#) [M160](#) [S5U1C17M13T2100](#) [S5U1C17M13T1100](#) [SG-210STF 7.3728ML3](#) [FC-12M 32.7680KA-AC0](#) [M150](#) [S5U1C17W15T2100](#) [XG-2121CA 156.2500M-PGSNB](#) [SG-210STF 32.7680ML](#) [SG-636PTF 20.0000MC3: ROHS](#) [SG-210STF 27.0000ML0](#) [SG-8002JC MP BLANK:ROHS](#) [SG5032CCN 14.745600M-HJGA3](#) [SG-615P 2.0000MC: ROHS](#) [Q13FC13F00001 FC-13F 32.768KHZ 12.5PF](#) [MA-306 18.4320M-C0:ROHS](#) [EG-2121CA 156.2500M-LHPAB](#)