

WORLD-BEAM QS30 LLP and LLPC



Polarized Retroreflective Laser Sensors



Features

- Visible class 1 laser with small, effective beam size
- Excellent optical performance throughout sensing range, even close up
- Easy push-button SET options: Maximum Excess Gain or Low-Contrast SET, depending on model, plus Manual Adjust
- Easy-to-read operating status indicators, with 8-segment bargraph display
- Bipolar discrete outputs, PNP and NPN
- Selectable 30 millisecond OFF-delay
- Models available with 2 m or 9 m (6.5' or 30') cable or integral quick-disconnect
- Tough ABS housing rated IEC IP67; NEMA 6
- Compact housing, mounting versatility – popular 30 mm threaded nose or side-mount

Excellent for applications where high sensing power and small beam size are important. Operates over sensing ranges typically accomplished only by conventional opposed-mode photoelectrics; uses a special filter to polarize the emitted light, filtering out unwanted reflections from shiny objects.

Models

Model	Range and Use	Spot Size at Focus	Cable*	Supply	Output Type
QS30LLP	0.2 to 18 m (0.67 ft to 60 ft) Maximum Excess Gain SET for Long-Range Applications	Approx. 4 mm at 10 m (0.16 in at 33 ft)	2 m (6.5 ft) 5-wire Cable	10 to 30V dc	Bipolar NPN / PNP
QS30LLPQ			Integral 5-pin Euro-style QD		
QS30LLPC	0.2 to 18 m (0.67 ft to 60 ft) Low-Contrast SET for Small Object Detection		2 m (6.5 ft) 5-wire Cable		
QS30LLPCQ			Integral 5-pin Euro-style QD		

* 9 m (30 ft) cables are available by adding suffix "W30" to the model number of any cabled sensor (e.g., QS30LLP W30). A model with a QD connector requires a mating cable (see [Quick-Disconnect Cables](#) on page 10).



WARNING: Not To Be Used for Personnel Protection

Never use this product as a sensing device for personnel protection. Doing so could lead to serious injury or death. This product does NOT include the self-checking redundant circuitry necessary to allow its use in personnel safety applications. A sensor failure or malfunction can cause either an energized or de-energized sensor output condition.



Excess Gain

With Supplied Target BRT-51X51BM

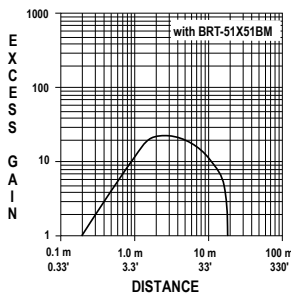

With Supplied Target BRT-TVHG-2X2

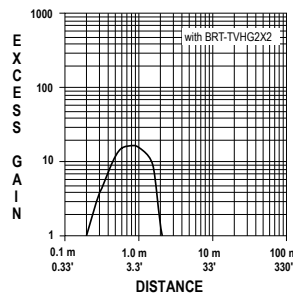

With Target BRT-2X2 (Optional)

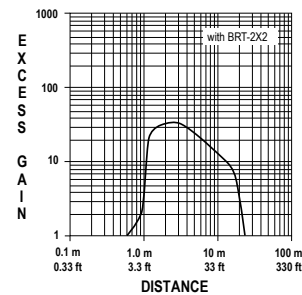

Overview

QS30LLP and QS30LLPC Series sensors are easy-to-use, high-performance laser sensors whose many configuration options make them suitable for demanding applications. Each sensor features two identically configured outputs, one each NPN and PNP.

The compact housing has a large, easy-to-see bargraph display plus bright LEDs for easy configuration and status monitoring during operation. The sensor can be side-mounted, using integral mounting holes, or front-mounted, via the 30 mm threaded barrel.

MODEL QS30LLP(Q) is configured using the Maximum Excess Gain SET procedure. It is useful for long-range applications and high variations in contrast, such as beam-break applications where the target objects are larger than the beam. See [Maximum Excess Gain SET - Model QS30LLP](#) on page 3 for more information.

MODEL QS30LLPC(Q) is configured using the Low-Contrast SET procedure. It is useful for small object detection and other applications with small variations in contrast, such as yarn- or thread-break applications. See [Low-Contrast SET - Model QS30LLPC](#) on page 5 for more information.

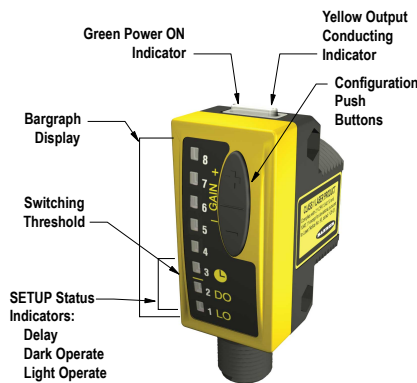

Figure 1. Model QS30LLP Features

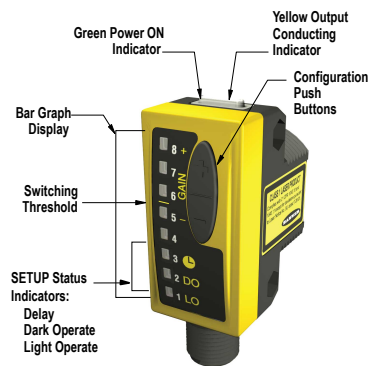

Figure 2. Model QS30LLPC Features

Sensor Configuration

Sensor configuration is accomplished using the SET and SETUP modes. After SET mode has defined the sensing parameters, SETUP mode may be used to add an OFF-delay or change the light/dark operate status. Manual Adjust may be used to fine-tune the thresholds. Two push buttons, “+” and “-”, may be used to access and set sensing parameters. In addition, the remote wire also may be used for some procedures (see below).

Remote Configuration

The Remote Configuration function may be used to set the sensor threshold remotely or to disable the push buttons for security. Connect the gray wire of the sensor to ground (0V dc), with a remote programming switch connected between them. Pulse the remote line according to the diagrams in the programming procedures. The length of the individual programming pulses is equal to the value T:

0.04 seconds ≤ T ≤ 0.8 seconds

Push Button Disable

In addition to its programming function, Remote Programming may be used to disable the push buttons for security. Disabling the push buttons prevents undesired tampering with the programming settings. Connect the gray wire of the sensor as described on above, and four-pulse to either enable or disable the push buttons:

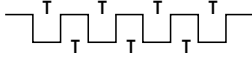

Maximum Excess Gain SET - Model QS30LLP

- Sets the sensor for maximum excess gain without allowing false proxing. Provides maximum contrast between any reflector and a blocked condition and is stable even in dirty environments.
- Useful for long-range applications and high variations in contrast, such as beam-break applications where the target objects are larger than the beam.

Sensor can be aimed at an object or the reflector during SET process to obtain the same result. All conditions darker than the switchpoint condition result in ON output (Dark Operate). Output ON and OFF conditions can be reversed by changing Light/Dark Operate in SETUP mode (factory setting: Dark Operate).

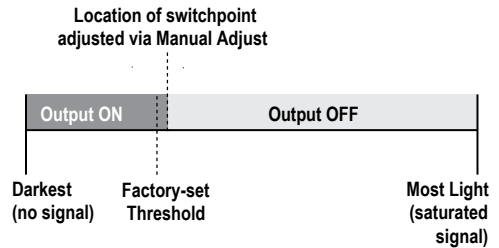

Figure 3. Maximum Excess Gain SET (Dark Operate shown)

Manual Adjust – Maximum Excess Gain SET

During RUN mode, adjusts switchpoint up or down via “+” or “-” push buttons.

- Each push button “click” adjusts the switchpoint up by approximately 0.5X excess gain or down by the same increments.
- The lighted bargraph LEDs move to reflect the increase or decrease of excess gain relative to the switchpoint.
- LEDs #7 and 8 flash when maximum gain is achieved; LEDs #1 and 2 flash when minimum gain is achieved.

When the received signal is at any level greater than 6X excess gain, the first “-” (minus) click to reduce excess gain reduces it to the 6X level. Subsequent “-” clicks result in decreased values as shown in [Specifications](#) on page 8 (approximately 2 clicks per LED change). To return to maximum excess gain, either press “+” repeatedly until LEDs #7 and 8 flash, or hold the “+” button for longer than 2 seconds. For example, in an application that results in 20X excess gain, pressing “-” once lowers the gain to 6X, exhibited by LED #8 ON. Pressing it twice more results in approximately 5X excess gain, exhibited by LED #7 ON. Holding the “+” button for 2 seconds results in a return to maximum gain (20X), exhibited by LEDs #7 and 8 flashing.

	Push Button	Remote (0.04 seconds ≤ T ≤ 0.8 seconds)	Indicators
Set Switchpoint	<ul style="list-style-type: none"> • Press and hold “+” > 2 seconds 	<ul style="list-style-type: none"> • Single-pulse remote line. 	<p>Green Power LED: OFF Yellow Output LED: ON Bargraph: #7 & 8 flashing</p> <ul style="list-style-type: none"> • Sensor returns to RUN mode with new settings • Use Manual Adjust to increase or decrease sensor excess gain

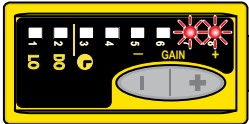
	Push Button	Remote (0.04 seconds ≤ T ≤ 0.8 seconds)	Indicators
			

Low-Contrast SET - Model QS30LLPC

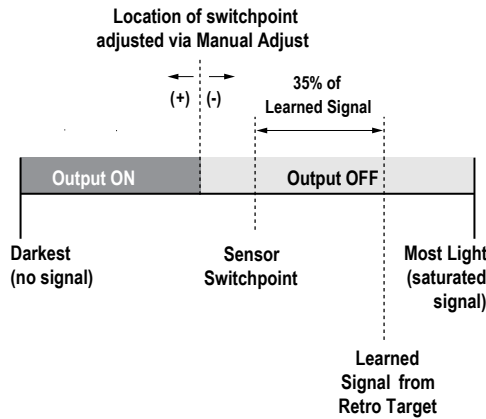

Figure 4. Low-Contrast SET (Dark Operate shown)



- Sets a switchpoint at 35 percent below the signal from the retroreflector.
- Useful for small object detection and other applications with small variations in contrast, such as yarn- or thread-break applications.
- Sensor must be aimed at the reflector during the SET process. All conditions darker than the switchpoint condition result in ON output (Dark Operate). Output ON and OFF conditions can be reversed by changing Light/Dark Operate in SETUP mode (factory setting: Dark Operate).

Manual Adjust – Low-Contrast SET

During RUN mode, adjusts switchpoint up or down via “+” or “-” push buttons.

- Each push button “click” adjusts the switchpoint up by 5 percent of the signal from the reflector or down by the same increments.
- The lighted bargraph LEDs move to reflect the increase or decrease in excess gain.
- LEDs #7 and 8 flash when maximum gain is achieved; LEDs #1 and 2 flash when minimum gain is achieved.

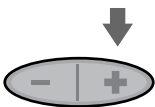
If the target object does not cause the output to change state, press the “-” button to decrease the gain, making the sensor more sensitive to small signal changes.

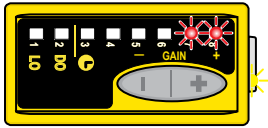
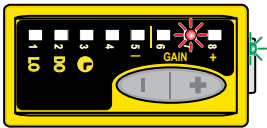
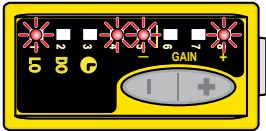
	Push Button	Remote (0.04 seconds < T ≤ 0.8 seconds)	Indicators
Set Switchpoint	<ul style="list-style-type: none"> • Align sensor to reflector • Press and hold "+" > 2 seconds 	<ul style="list-style-type: none"> • Align sensor to reflector • Single-pulse remote line. 	<p>Green Power LED: OFF Yellow Output LED: ON</p> 
Sensor Feedback	<p>Switchpoint Accepted</p> <p>Bargraph: #7 and 8 flash for 2 sec Yellow Power LED: OFF Green Power LED: ON Bargraph: Appropriate LED ON</p> <ul style="list-style-type: none"> • Sensor returns to RUN mode with new settings. • Use Manual Adjust to increase or decrease sensor sensitivity. 		<p>Switchpoint Unacceptable</p> <p>Bargraph: #1, 4, 5, and 8 flash for 2 sec Green Power LED: ON</p> <ul style="list-style-type: none"> • Sensor returns to RUN mode without saving (maintains previous settings) 

SETUP Mode

SETUP mode is accomplished via the sensor's two push buttons. It is used to change sensor output response for:

- Light or Dark Operate
- 30-millisecond pulse stretcher (OFF-delay), if required.

The status LEDs, active only during SETUP mode, indicate the output response configuration when the sensor will be in RUN mode.

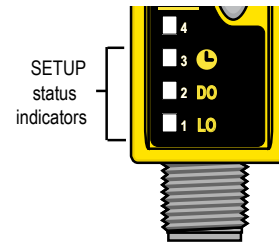

Figure 5. SETUP Mode

	Push Button 0.04 seconds < T < 0.8 seconds	Result
Access SETUP Mode	<ul style="list-style-type: none"> • Press and hold both push buttons > 2 seconds 	<ul style="list-style-type: none"> • Green Power LED turns OFF
Select SETUP Options	<ul style="list-style-type: none"> • Click either push button to toggle through the four possible setting combinations. 	 DO, No Delay
		 DO 30 ms Delay
	or	 LO, 30 ms Delay
		 LO, No Delay
Return to RUN Mode	<ul style="list-style-type: none"> • Press and hold both push buttons > 2 seconds 	<ul style="list-style-type: none"> • Green Power LED turns ON

Installation Notes

Conventional retroreflective photoelectric sensors are extremely easy to align. Beam angles are wide, and retro targets are forgiving to the light beam's angle of incidence. The beam of this laser sensor is very narrow, compared with the beam of most retro sensors. As Figure 6 indicates, the effect of angular misalignment can be dramatic. Alignment is critical because the beam may miss the retroreflective target unless the target is large.

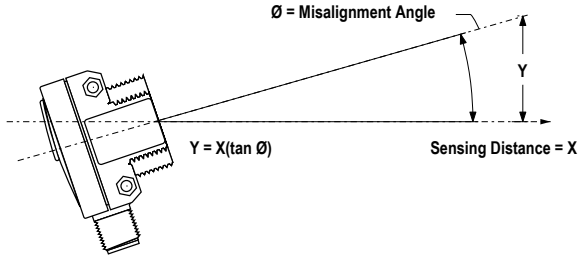

Figure 6. Beam Displacement per degree of misalignment

Sensor-to-Target Distance (X)	Beam Displacement (Y) for 1° of Misalignment
1.5 m (5 ft)	25 mm (1 in)
3 m (10 ft)	50 mm (2 in)
6 m (20 ft)	100 mm (4 in)
15 m (50 ft)	250 mm (10 in)
30 m (100 ft)	500 mm (20 in)

For example, with one BRT-51X51BM mounted at a distance of 6 m (20 ft) from the sensor, one degree of angular misalignment will cause the center of the laser beam to miss the center of the target by 100 mm (4 in).

Alignment Tip

When using a small retroreflective target at medium or long range, it is often useful to temporarily attach (or suspend) a strip of retroreflective tape (e.g., BRT-TVHG-2X2) along a line that intersects the actual target. The visible red laser beam is easily seen in normal room lighting on such tape. Sight along the beam toward the target (from behind the sensor). Move the sensor to scan the laser beam back and forth across the retro tape strip. Use the tape strip to guide the beam onto the target.

Consider using sensor mounting bracket model SMB30SC (see [Accessory Brackets](#) on page 11). This swivel bracket can simplify multiple-axis alignment. Alignment is complete when the visible image is centered on the retro target. The perpendicularity of the laser beam to the face of the retro target is forgiving, just as it is with a conventional retroreflective sensor.

Effective Beam Size

Unlike conventional retroreflective sensors, the retroreflective laser has the ability to sense relatively small profiles. Figure 7 indicates the diameter of the smallest opaque rod which will reliably break the laser beam at several sensor-to-object distances using sensor model QS30LLP(Q). These minimum object sizes were measured with the sensor aligned to a BRT-51X51BM reflector and the gain set to maximum using the Max Excess Gain SET. This sensor is typically recommended for long-range applications of relatively small targets that will completely break the beam.

Figure 7. Minimum object detection size vs. distance from sensor, model QS30LLP(Q)

Sensor-to-Object Distance (X)	Minimum Object Detection Size
0.3 m (1 ft)	2.5 mm (0.10 in)
1.5 m (5 ft)	5.0 mm (0.20 in)
3 m (10 ft)	7.0 mm (0.28 in)
18 m (59 ft)	13 mm (0.52 in)

Smaller objects can be detected by using model QS30LLPC(Q), adjusting the sensor gain down using the Manual Adjust, or performing a Low-Contrast SET of the reflector. Objects as small as 2.0 mm can be reliably detected after performing the Low-Contrast SET at ranges up to 6 m (18 ft). This sensor is typically recommended for shorter-range applications detecting very small targets that may break only a portion of the beam.

Note that the shape of the beam is elliptical. The minimum object sizes listed assume passage of the rod across the major diameter of the ellipse (worst case). It may be possible to detect objects smaller than the sizes listed if the direction in which the objects pass through the beam can be controlled.

Retroreflector Recommendations

- BRT-51X51BM recommended for beam-block applications up to 18 m range.
- BRT-TVHG-2X2 recommended for applications up to 2 m range. (This retroreflector is an adhesive-backed sealed tape with micro-prism geometry.)

Specifications

Supply Voltage and Current

10 to 30V dc (10% max. ripple at 10% duty cycle) at 35 mA max current, exclusive of load

Sensing Beam

Visible red LED, 650 nm

Laser Classification

Class 1

Beam Size at Aperture

Approx. 3 mm

Supply Protection Circuitry

Protected against reverse polarity, over voltage, and transient voltages

Delay at Power-Up

1 second max.; outputs do not conduct during this time

Output Configuration

Solid-state bipolar (SPDT): 1 current sourcing (PNP) and 1 current sinking (NPN)

Rating: 150 mA maximum load

Off-state leakage current: < 10 μ A at 30V dc

ON-state saturation voltage:

- **NPN:** less than 1.0V at 150 mA load
- **PNP:** less than 2.0V at 150 mA load

Output Protection Circuitry

Protected against output short-circuit, continuous over-load, transient over-voltages, and false pulse on power-up

Output Response

500 microseconds

Repeatability

70 microseconds

Adjustments

2 push buttons and remote wire

- Easy push-button configuration
- Manually adjust (+/-) thresholds (push buttons only)
- LO/DO and OFF-delay configuration options
- Push-button lockout (from remote wire only)

Factory Defaults:

- No Delay
- Dark Operate
- Push buttons enabled

Indicators

Output conducting

8-Segment Red Bargraph

SETUP mode:

- Flashes Red when delay is selected
- Flashes Red when Dark Operate is selected
- Flashes Red when Light Operate is selected

RUN mode:

Model QS30LLP	Model QS30LLPC
LED 8: >6X	LED 8: >2X
LED 7: 5-6X	LED 7: 1.5-2X
LED 6: 4-5X	LED 6: 1-1.5X
LED 5: 3-4X	LED 5: 0.8X
LED 4: 2-3X	LED 4: 0.6X
LED 3: 1-2X	LED 3: 0.4X
LED 2: 0.5-1X	LED 2: 0.2X
LED 1: 0-0.5X	LED 1: 0X

Sensor calibration failure:

Construction

Environmental Rating

IEC IP67; NEMA 6

Connections

5-conductor 2 m (6.5 ft) PVC cable, 9 m (30 ft) PVC cable, or 5-pin integral Euro-style quick-disconnect fitting

Operating Conditions

Temp: -10° to +50° C (+14° to 122° F)

Relative Humidity: 90% at 50° C (non-condensing)

Vibration and Mechanical Shock

All models meet Mil. Std. 202F requirements. Method 201A (Vibration: 10 to 60Hz max. double amplitude 0.06 in, maximum acceleration 10G). Also meets IEC 947-5-2 requirements: 30G, 11 ms duration, half sine wave.

Certifications



Description of Laser Classes

Class 1 Lasers

Lasers that are safe under reasonably foreseeable conditions of operation, including the use of optical instruments for intrabeam viewing. Reference IEC 60825-1:2001, Section 8.2.



CAUTION: Do Not Disassemble for Repair

Use of controls or adjustments or performance of procedures other than those specified herein may result in hazardous radiation exposure. Do NOT attempt to disassemble this sensor for repair. A defective unit must be returned to the manufacturer.



For Safe Laser Use (Class 1 or Class 2):

- Do not permit a person to stare at the laser.
- Do not point the laser at a person's eye at close range.
- Mount open laser beam paths either above or below eye level, where practical.
- Terminate the beam emitted by the laser product at the end of its useful path.

Dimensions

Cabled Models

QD Models

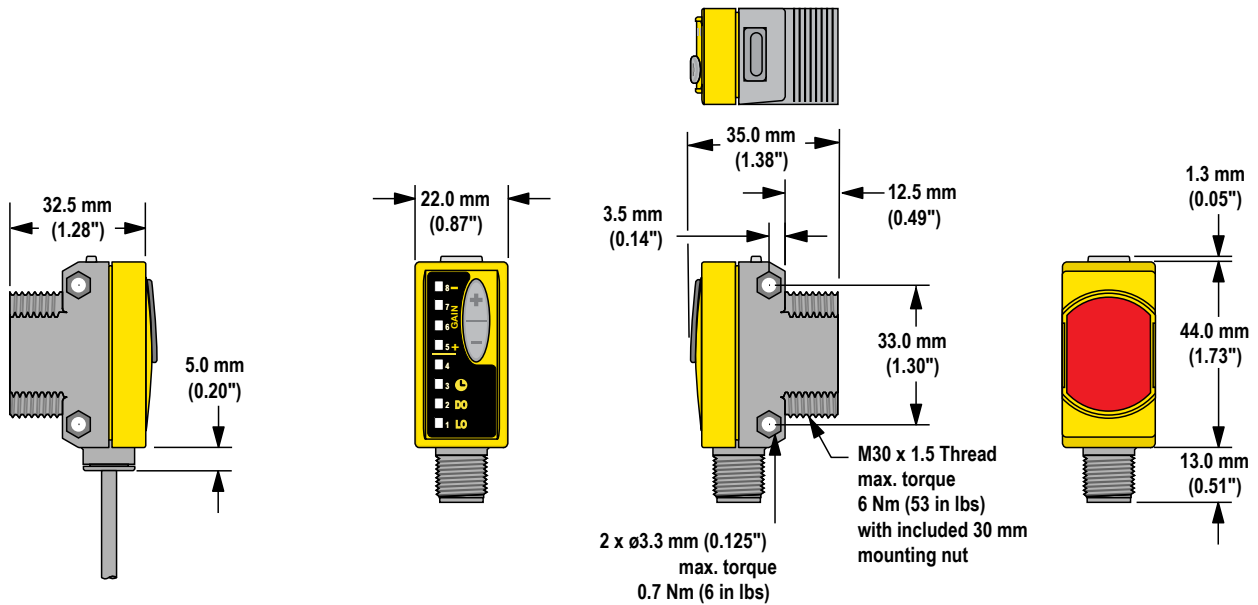

Hardware Included: (2) M3 x 0.5 x 28 stainless steel machine screws, nuts, and washers

Hookups

Cabled Models

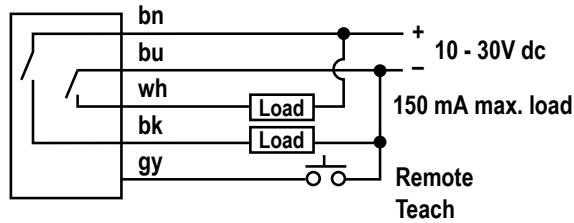

QD Models

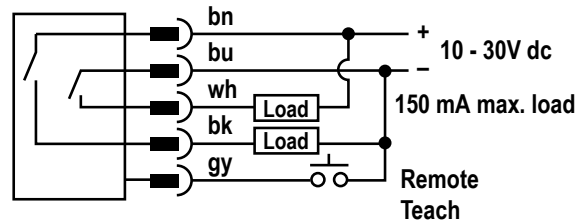

Note: Pink wire not used

Accessories

Quick-Disconnect Cables

5-Pin Threaded M12/Euro-Style Cordsets				
Model	Length	Style	Dimensions	Pinout
MQDC1-501.5	0.50 m (1.5 ft)	Straight		<p>1 = Brown 2 = White 3 = Blue 4 = Black 5 = Gray</p>
MQDC1-506	1.83 m (6 ft)			
MQDC1-515	4.57 m (15 ft)			
MQDC1-530	9.14 m (30 ft)			
MQDC1-506RA	1.83 m (6 ft)	Right-Angle		
MQDC1-515RA	4.57 m (15 ft)			
MQDC1-530RA	9.14 m (30 ft)			

5-Pin Threaded M12/Euro-Style Cordsets				
Model	Length	Style	Dimensions	Pinout
MQDC1-501.5	0.50 m (1.5 ft)	Straight		<p>1 = Brown 2 = White 3 = Blue 4 = Black 5 = Gray</p>
MQDC1-506	1.83 m (6 ft)			
MQDC1-515	4.57 m (15 ft)			
MQDC1-530	9.14 m (30 ft)			
MQDC1-506RA	1.83 m (6 ft)	Right-Angle		
MQDC1-515RA	4.57 m (15 ft)			

5-Pin Threaded M12/Euro-Style Cordsets				
Model	Length	Style	Dimensions	Pinout
MQDC1-530RA	9.14 m (30 ft)			

Retroreflective Targets

For additional information and a complete list of accessories, please refer to Banner Engineering website <http://www.bannerengineering.com>



NOTE: Polarized sensors require corner cube type retroreflective targets only.



<p>BRT-2X2</p> <ul style="list-style-type: none"> • Square, acrylic target • Reflectivity factor: 1.0 • Max. temperature: +50 °C (+122 °F) • Optional brackets are available • Approximate size: 51 mm x 51 mm 	<p>BRT-51X51BM</p> <ul style="list-style-type: none"> • Square, acrylic target • Reflectivity Factor: 1.5 • Max. Temperature: +50 °C (+122 °F) • Micro-prism geometry • Optional brackets are available • Approximate size: 51 mm x 51 mm
--	--

Retroreflective Tape

Model	Reflectivity Factor	Maximum Temperature	Size
BRT-TVHG-2X2	0.8	+60°C (+140°F)	50 x 50 mm

Accessory Brackets

Models	
<p>SMB30SC</p> <ul style="list-style-type: none"> • Swivel bracket with 30 mm mounting hole for sensor • Black reinforced thermo-plastic polyester • Stainless steel mounting and swivel locking hardware included <p>Hole center spacing: A=∅ 50.8</p>	<p>SMBQS30L</p> <ul style="list-style-type: none"> • Right-angle bracket for cable sensor models • Clearance for M4 (#8) hardware • ± 12° tilt adjustment • 14-ga. stainless steel <p>Hole center spacing: A to B=35.0</p>

Models	
Hole size: A=∅ 7.0, B=∅ 30.0	Hole size: A=∅ 4.3, B=∅ 4.25x16.3
<p>SMBQS30LT</p> <ul style="list-style-type: none"> • Tall right-angle bracket for QD models • ± 8° tilt adjustment • 14-ga. stainless steel  <p>Hole center spacing: A to B=35.0 Hole size: A=∅ 4.3, B=∅ 4.25x16.3</p>	<p>SMBQS30Y</p> <ul style="list-style-type: none"> • Heavy-duty die-cast bracket • M18 vertical mount option • ± 8° tilt adjustment with cabled units • Includes nuts and lock washer  <p>Hole size: A=∅ 15.3</p>



CAUTION: Do Not Disassemble for Repair

Use of controls or adjustments or performance of procedures other than those specified herein may result in hazardous radiation exposure. Do NOT attempt to disassemble this sensor for repair. A defective unit must be returned to the manufacturer.

Banner Engineering Corp Limited Warranty

Banner Engineering Corp. warrants its products to be free from defects in material and workmanship for one year following the date of shipment. Banner Engineering Corp. will repair or replace, free of charge, any product of its manufacture which, at the time it is returned to the factory, is found to have been defective during the warranty period. This warranty does not cover damage or liability for misuse, abuse, or the improper application or installation of the Banner product.

THIS LIMITED WARRANTY IS EXCLUSIVE AND IN LIEU OF ALL OTHER WARRANTIES WHETHER EXPRESS OR IMPLIED (INCLUDING, WITHOUT LIMITATION, ANY WARRANTY OF MERCHANTABILITY OR FITNESS FOR A PARTICULAR PURPOSE), AND WHETHER ARISING UNDER COURSE OF PERFORMANCE, COURSE OF DEALING OR TRADE USAGE.

This Warranty is exclusive and limited to repair or, at the discretion of Banner Engineering Corp., replacement. **IN NO EVENT SHALL BANNER ENGINEERING CORP. BE LIABLE TO BUYER OR ANY OTHER PERSON OR ENTITY FOR ANY EXTRA COSTS, EXPENSES, LOSSES, LOSS OF PROFITS, OR ANY INCIDENTAL, CONSEQUENTIAL OR SPECIAL DAMAGES RESULTING FROM ANY PRODUCT DEFECT OR FROM THE USE OR INABILITY TO USE THE PRODUCT, WHETHER ARISING IN CONTRACT OR WARRANTY, STATUTE, TORT, STRICT LIABILITY, NEGLIGENCE, OR OTHERWISE.**

Banner Engineering Corp. reserves the right to change, modify or improve the design of the product without assuming any obligations or liabilities relating to any product previously manufactured by Banner Engineering Corp.

X-ON Electronics

Largest Supplier of Electrical and Electronic Components

Click to view similar products for [Photoelectric Sensors](#) category:

Click to view products by [Banner](#) manufacturer:

Other Similar products are found below :

[E3JM-DS70R4T-US](#) [E3L2DC4](#) [E3RA-DN12 2M](#) [E3RA-DP12 2M](#) [E3S5LE4S](#) [E3S-AD38](#) [E3S-CR11 5M](#) [E3SCT11D5M](#) [E3SCT11M1J03M](#)
[E3T-SL14R](#) [E3T-SL24 5M](#) [E3T-ST12R](#) [E3X-CN02](#) [E3X-CN11 5M](#) [E3X-CN21 10M](#) [E3ZM-B66](#) [E3ZM-CL81H 2M](#) [E3Z-T62 2M](#)
[NJL5303R-TE1](#) [PB10CNT15PO](#) [PD60CNX20BP](#) [CX-491-P-J](#) [CX-491-Z](#) [XUM2BKCNL2T](#) [XUM2BKCNL2T](#) [XUM2BNANL2R](#) [Y92E-](#)
[ES30M](#) [Y92E-GS08SS](#) [ZXTDS04T](#) [ZX-XC4A 4M](#) [E3E23Y2US](#) [E3JM-DS70S4-US](#) [E3RA-RN11 2M](#) [E3S5LE42M](#) [E3S-LS20XB4 5M](#)
[E3TFD14N](#) [E3T-FD14R](#) [E3T-SL21 5M](#) [E3T-SL21M](#) [E3T-ST11R](#) [E3T-ST12 5M](#) [E3X-DA41-S-M1J 0.3M](#) [E3X-DAB6](#) [E3X-DAG8](#) [E3ZM-](#)
[B86](#) [E3ZM-CR81 2M](#) [E3ZM-CR86](#) [E3Z-T61A-L 2M](#) [ZX-XGC2R](#) [ZX-XB1A](#)