

VCC

lighting:theway

OPTOELECTRONICS

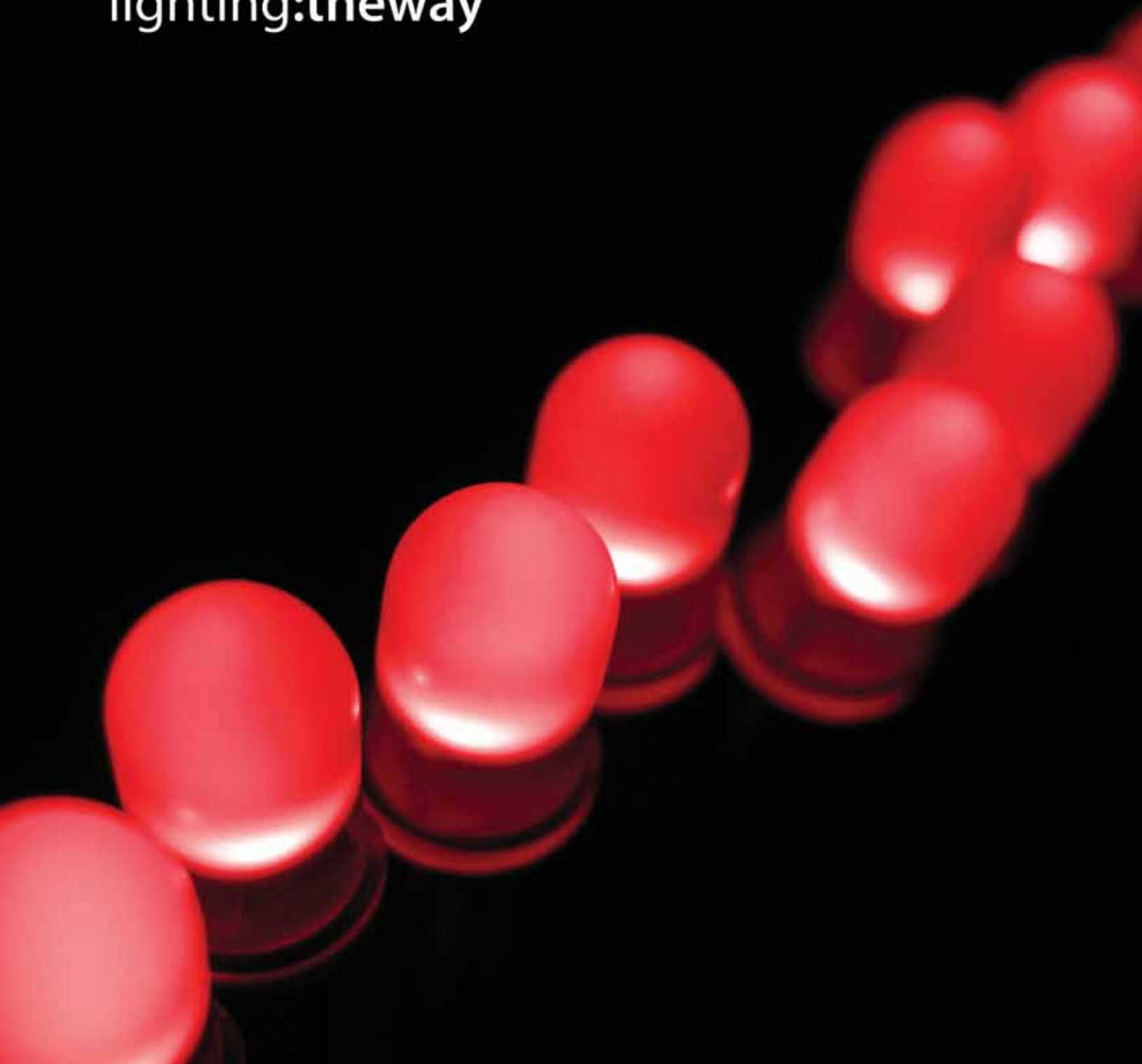



“ *With over three decades of history and operational excellence, VCC brings together the resources and talent of the industry’s most committed team of professionals to create a dynamic, collaborative environment with our customers that consistently results in real product advancements and solutions.* ”

VCC is a fully integrated company that changes the way engineers approach LED mounting solutions. From the design stage to market, we apply cutting-edge technology to turn ideas into results. We offer OEMs and our other customers total collaboration, as well as a single source for mounting LEDs. And we do it faster and at a lower cost than the competition. Through an extensive domestic and international distribution network, VCC delivers value in products and innovation in light.

Operating from our modern facilities in San Diego, California, we combine years of experience in product engineering, design, development, and manufacturing to efficiently meet our customers’ needs.

Visual Communications Company, Inc. is recognized as a pioneer in the development and delivery of today’s most innovative solutions for the Optoelectronics industry. Since 1975, we have created the industry’s most comprehensive line of mounting devices for LEDs.



lighting:theway

VISUAL COMMUNICATIONS COMPANY, INC.

190 Bosstick Blvd. • Suite 101
San Marcos, California 92069 • U.S.A.

© 2011 Visual Communications Company, Inc.



LITEPIPES®

- FLEXFIRE™ FLEXIBLE LITEPIPE® 04
- LITEPIPE® FOR SMD AND THROUGH-HOLE LEDs 05
- MICRO-LITEPIPE® 06
- MOISTURE-SEALED LITEPIPE® ASSEMBLIES 07



PANEL LENSES

- PANEL LENS AND LITEPIPE® COMBINATION 09
- STANDARD LENS MOUNTS..... 10
- LOW-PROFILE LENS MOUNTS..... 12
- MOISTURE-SEALED LENS MOUNTS..... 13
- THREADED LENS MOUNTS..... 14



INTERCONNECTORS

- PANEL MOUNT ASSEMBLIES 16
- HEADERS AND CONNECTORS 23



PANEL MOUNTS + CLIPS

- PANEL MOUNTS FOR IR & VISIBLE LED DEVICES 25
- MOUNTING CLIPS 26
- SOLDERLESS LED CONNECTOR 26



CIRCUIT BOARD MOUNTS

- LED SOCKETS 27
- STANDOFFS..... 28



LEDS

- THROUGH-HOLE 29
- SMD 32
- RGB 33
- POWER 33
- SEVEN-SEGMENT..... 34
- DOT-MATRIX..... 34



FLEXFIRE™ FLEXIBLE LITEPIPE®



FLX Series shown in picture. U.S. & Foreign Patents Issued.

FLX SERIES

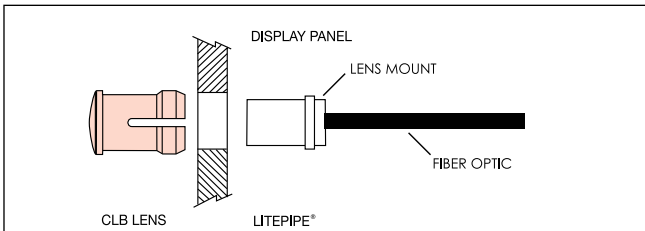

Panel mounting hole .250" on 3/8" centers. Panel thickness for CLF 280: 1/16" to 1/8"; CLB 300, CLR 301 and SQB 400: 1/32" to 1/4". For panels less than 3/16" use SPC spacer. Panel Lens-Polycarbonate (UL Rating 94-V2), Spacer and Retaining Ring-Polypropylene.

FLX 44X SERIES

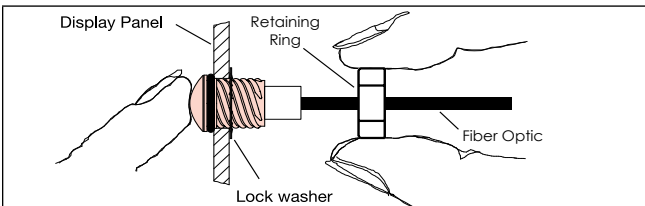

Mounts through front of panel. Secured by retaining ring. Lenses mount through a 5/16" hole on 1/2" centers. Panel thickness 1/32" to 1/8". Lens-Polycarbonate (UL Rating 94-V2), Lock Washer-FH Steel, Nickel Plate, Retaining Ring-Thermoplastic (UL 94-V0), Seal-EPDM

FLX 322 SERIES

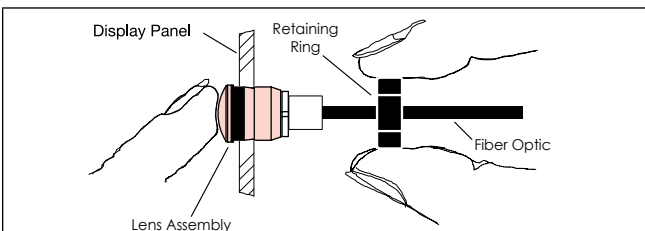

Mounts through front of panel. Compression of the seal is accomplished by pressing the retaining ring in place. Lenses mount through a 9/32" hole on 3/8" centers. Panel thickness 1/32" to 1/8". Lens-Polycarbonate (UL Rating 94-V2), Retaining Ring-Polypropylene, Seal-TPE

SPECIFICATIONS

APPLICATION	Flexfire™ flexible light pipes provide the simplest method of transmitting light from a PCB-mounted (Through Hole or SMD) LED to a front panel. It offers wide design capabilities for lens styles that include wide angle, moisture-sealed, and high profile. VCC's FLX Series flexible light pipes have many advantages over legacy copper wire solutions: Immune to electromagnetic interference (EMI), Does not conduct or transfer electrostatic discharge (ESD) pulses, Non-conductive light path- pinching of copper wires has the potential to cause electrical shorting, which may damage components, No solder or crimp terminations, Single versus multiple conductors, Graceful degradation under "extreme" bending conditions
MATERIAL	<ul style="list-style-type: none"> Optical Fiber: Core-Acrylic (Optical Grade), Jacket-Polyethylene Optical core ends polished to 10 microns Lens Mount - Acrylic (Optical Grade) LED Mount - Nylon 66 (UL Rating 94-V2)

ORDERING CODES

FLX 02

LITEPIPE®
Length
2.0"
4.0"
6.0"
8.0"
12.0"

LENS OPTIONS

CLF 280
CLB 300
CLR 301
SQB 400

ORDERING CODES

FLX 442

BTP

O6

MODEL
CMC 441 Standard Fresnel
CMS 442 Moisture-Sealed Fresnel
CMC 443 Plain End
CMS 444 Moisture-Sealed Plain End

COLOR

RTP Red Transparent
ATP Amber Transparent
GTP Green Transparent
BTP Blue Transparent
YTP Yellow Transparent
CTP Clear Transparent

LITEPIPE®
Length
2.0"
4.0"
6.0"
8.0"
12.0"

ORDERING CODES

FLX 322

BTP

O6

MODEL
CMC 322 Low Profile Fresnel Lens With Moisture Seal.
Includes Seal And Retaining Ring

COLOR

RTP Red Transparent
ATP Amber Transparent
GTP Green Transparent
BTP Blue Transparent
YTP Yellow Transparent
CTP Clear Transparent
GLO White Translucent

LITEPIPE®
Length
2.0"
4.0"
6.0"
8.0"
12.0"

MOUNTING OPTIONS

ORDER SEPARATELY

SMD 22

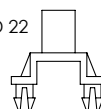

THR 22

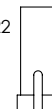



SPECIFICATIONS

MATERIAL	LITEPIPE® - Acrylic, optical grade, (Clear) Grommet - TPE Spring Clip - Spring Steel (nickel plate)
MOUNTING	Panel hole: round .171" Dia.(4.34mm). square .180" x .180" (4.57mm x 4.57mm). rectangular .170" x .250" (4.34mm x 6.35mm). LITEPIPE® from .200" to .500" use grommet retainer (RTN 150). LITEPIPE® from .500" to 2.00" the spring clip (RTN250) is recommended for rigidity.
LED	Surface mount, vertical and horizontal LEDs. LITEPIPE® products for blending multicolor LEDs are available.
STANDOFF	Use standoff to adjust height of standard LED above the PCB in order to maintain a maximum .050" clearance between LITEPIPE® and LED. See STD Series data sheet on page 28.



U.S. & Foreign Patents Issued.

LITEPIPE® WITH VERTICAL SURFACE MOUNT LED

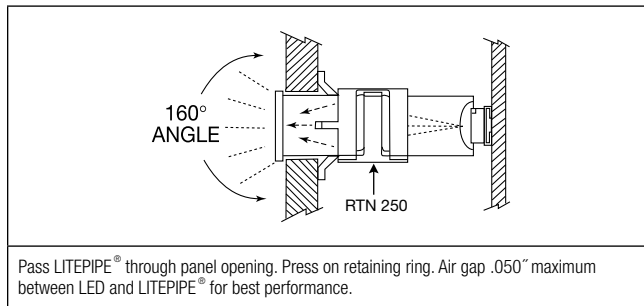

LITEPIPE® WITH HORIZONTAL SURFACE MOUNT LED

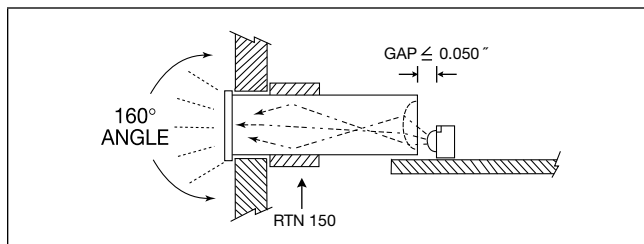

APPLICATION

VCC's LITEPIPE® provides a method of transmitting the light of a surface mount LED to the display panel. Vertical and horizontal PCB and surface mount LEDs can be displayed in this manner. The LITEPIPE® is also capable of blending multicolor LED light into a single color.

INTENSITY

LITEPIPE® lightpipes have a unique near flush design and are still able to provide up to 160 degrees of viewing angle. This light output is achieved by the use of a concave shaped receiving surface which collects the LEDs light, and fresnel rings on the opposite surface that disperse the light.

VERSATILITY

The LITEPIPE® is available in .020" increments from .200" to 2.0". This wide range of lengths simplifies the PCB positioning in relation to the display panel. Lightpipes are secured directly to the display panel with no mechanical attachment to the PCB. The installation and removal of the circuit board can thus be accomplished without disturbing the display panel.

INSTALLATION

LITEPIPE® products are easy to install. Slide the LITEPIPE® through the panel opening and slip the retainer in place. Finish the installation by pressing the retainer up against the display panel.

ORDERING CODES

	LPC	XXX	CTP	
MODEL	_____			COLOR
LPC (Round)				CTP CLEAR
LPS (Square)				
LPR (Rectangular)				
RTN 150 (GROMMET)				
RTN 250 (SPRING CLIP)				
			Equals length in inches (Min. 020 = .200" / Max. 200 = 2.0")	

020	038	056	074	092	112	135	157	180
022	040	058	076	094	115	137	160	182
024	042	060	078	096	117	140	162	185
026	044	062	080	098	120	142	165	187
028	046	064	082	100	122	145	167	190
030	048	066	084	102	125	147	170	192
032	050	068	086	105	127	150	172	195
034	052	070	088	107	130	152	175	197
036	054	072	090	110	132	155	177	200

NOTE:

Round: .200" to 2.0" Square & Rectangular: .300" to 2.0"
(Not all sizes carried in stock.)
Special lengths available upon request. Minimum order quantity may apply.

OUTLINE DRAWING

<p>LPR</p> <p>Rectangular .190 X .270 (4.83mm X 6.86mm)</p>	<p>LPS</p> <p>Square .200 X .200 (5.08mm X 5.08mm)</p>	<p>LPC</p> <p>Round .190 Dia. (4.83mm)</p>	<p>RTN 150</p> <p>GROMMET</p>	<p>RTN 250</p> <p>SPRING CLIP</p>
--	---	---	--------------------------------------	--



U.S. & Foreign Patents Issued.

VERSATILITY

The 2.5mm LITEPIPE® provides a method of transmitting the light from PCB mounted LEDs to the front display panel. Both styles of LEDs, surface mount, 3mm and 5mm standard packages can be displayed in this manner.

BRIGHTNESS

The LITEPIPE® increases the apparent brightness and viewing angle of a PCB-mounted LED. The LITEPIPE® transmits the light from the source to the lens, which in turn disperses the light up to 160 degrees.

APPLICATION

The 2.5mm LITEPIPE® is available for use with both surface mount and standard package 3mm and 5mm LEDs. Because there is no physical connection between the LITEPIPE® and PCB mounted LED, the circuit board can be installed or removed without disturbing the panel display.

INSTALLATION

The LITEPIPE® assembly is easily installed. Pass the LITEPIPE® through the panel opening and press on grommet retainer to secure unit to the panel. Slide PCB into position aligning LED with the end of the LITEPIPE®.

SPECIFICATIONS

MATERIAL	LITEPIPE® - Acrylic (Clear optical grade) Grommet - TPE
DESIGN	Low profile, small diameter LITEPIPE®.
MOUNTING	Mounts in .102" (2.59mm) hole on 3/16" centers. Use grommet retainer (RTN 100).
LED	Surface mount, vertical and horizontal LEDs. LITEPIPE® products for blending multicolor LEDs are available.
STANDOFF	Use standoff to adjust height of standard LED above the PCB in order to maintain a maximum .050" clearance between LITEPIPE® and LED. See STD Series data sheet on page 28.

SURFACE MOUNT LED APPLICATION

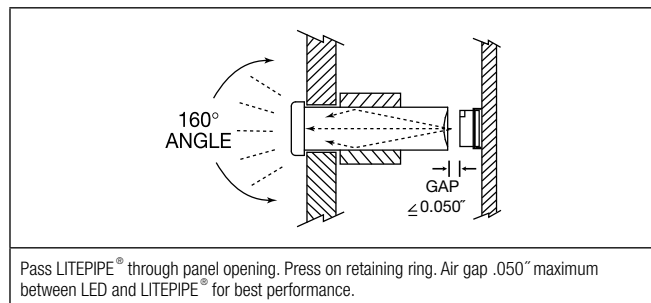

ORDERING CODES

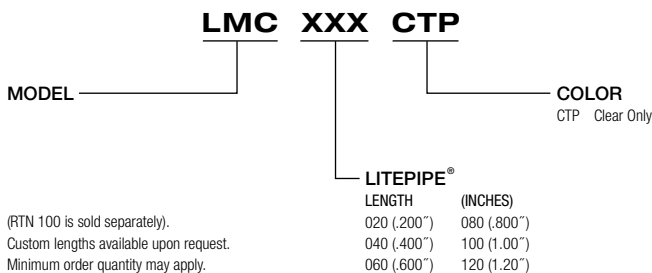

THROUGH-HOLE LED APPLICATION

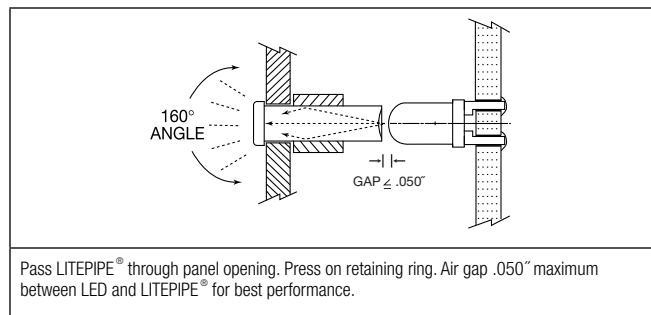

OUTLINE DRAWING

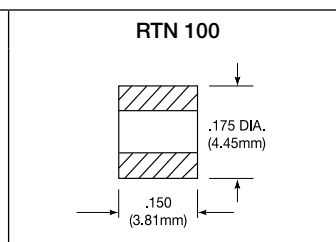
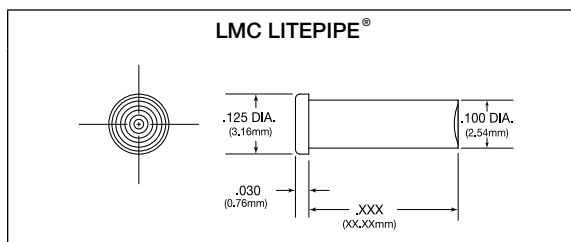

RECOMMENDED LEDs

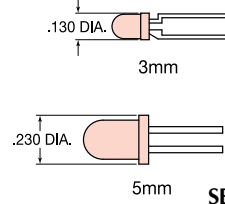



MOISTURE SEALED LITEPIPE® ASSEMBLIES

SPECIFICATIONS

MATERIAL	LITEPIPE® - Acrylic (Clear optical grade) CLIPLITE® Lens - Polycarbonate, Seal - EPDM Lock washer - FH Steel, Nickel plate Ring - Thermoplastic (white) (U.L. Listed Materials)
DESIGN	Low profile threaded lens assembly with moisture seal and LITEPIPE®.
MOUNTING	Mounts in 5/16" (8.0mm) hole on 1/2" centers. Panel thickness 1/32" to 1/8". Compression of the seal is accomplished by twisting the retaining ring into place.
STANDOFF	Use standoff to adjust height of standard LED above the PCB in order to maintain a maximum .050" clearance between LITEPIPE® and LED. See STD Series data sheet on page 28.



U.S. & Foreign Patents Issued.

APPLICATION

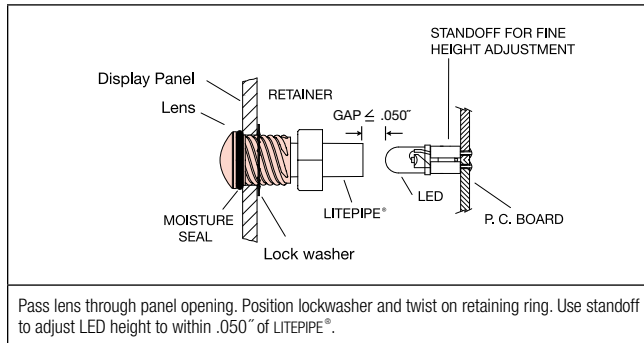

VERSATILITY

The LITEPIPE® moisture-sealed assembly provides a method of transmitting the light from PCB mounted LEDs to the front display panel while providing moisture protection. Both styles of LEDs, surface mount, 3mm and 5mm standard packages can be displayed in this manner.

BRIGHTNESS

The LITEPIPE® assembly increases the apparent brightness and viewing angle of a PCB mounted LED. LITEPIPE® transmits the light from the source to the lens, which in turn disperses the light up to 180 degrees.

APPLICATION

The LITEPIPE® threaded assembly exceeds NEMA 6P for water, ice and dust conditions when properly installed. Because there is no physical connection between the lightpipe and PCB mounted LED, the circuit board can be installed or removed without disturbing the panel display.

INSTALLATION

The LITEPIPE® and lens assembly is easily installed. Pass assembly through the panel opening and position the lockwasher behind the panel. Tighten retaining ring to secure unit to the panel. Slide PCB into position aligning LED with the end of the LITEPIPE® unit.

PANEL ASSEMBLY

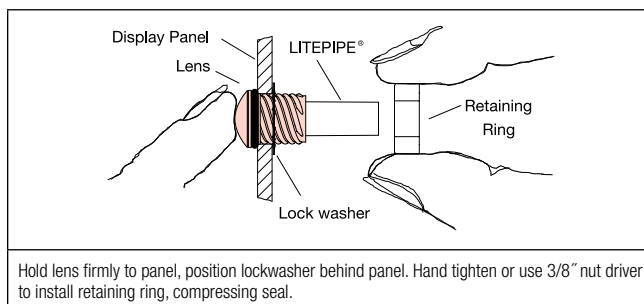

ORDERING CODES

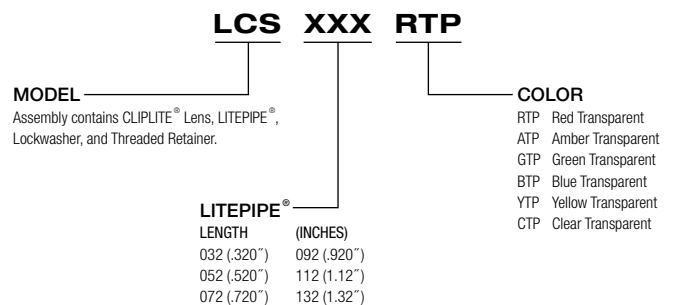

OUTLINE DRAWING

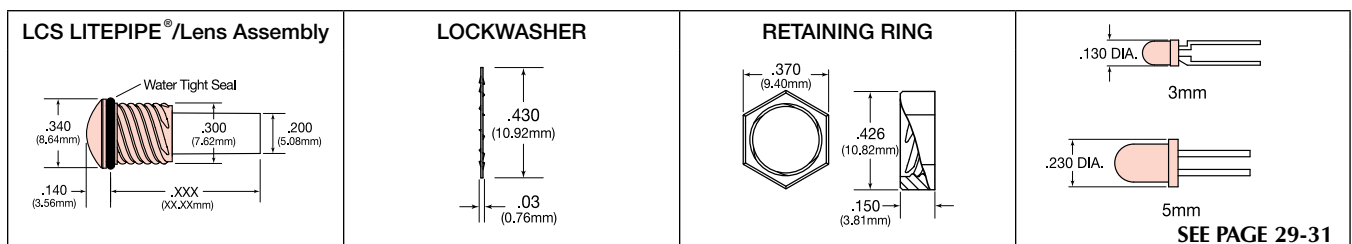



MOISTURE SEALED LITEPIPE® ASSEMBLIES



U.S. & Foreign Patents Issued.

VERSATILITY

The LITEPIPE® assembly provides a method of transmitting the light from PCB mounted LEDs to the front display panel while providing moisture protection. Both styles of LEDs, surface mount, 3mm and 5mm standard packages can be displayed in this manner.

BRIGHTNESS

LITEPIPE® increases the apparent brightness and viewing angle of a PCB mounted LED. LITEPIPE® transmits the light from the source to the lens, which in turn disperses the light up to 180 degrees.

APPLICATION

The LITEPIPE® assembly meets NEMA 4 conditions for moisture and dust. Because there is no physical connection between the lightpipe and PCB mounted LED, the circuit board can be installed or removed without disturbing the panel display.

INSTALLATION

The LITEPIPE® and CLIPLITE® lens assembly is easily installed. Pass assembly through the panel opening and press on retaining ring to secure unit to the panel. Slide PCB into position aligning LED with the end of the LITEPIPE® unit.

SPECIFICATIONS

MATERIAL	LITEPIPE® - Acrylic (Clear optical grade) CLIPLITE® Lens - Polycarbonate, Seal - TPE Retaining Ring - Polypropylene (black) (U.L. Listed Materials)
DESIGN	Low profile lens assembly with moisture seal and LITEPIPE®.
MOUNTING	Mounts in .281" (7.2mm) hole on 3/8" centers. Panel thickness 1/32" to 1/8". Compression of the seal is accomplished by pressing the retaining ring into place.
STANDOFF	Use standoff to adjust height of standard LED above the PCB in order to maintain a maximum .050" clearance between LITEPIPE® and LED. See STD Series data sheet on page 28.

APPLICATION

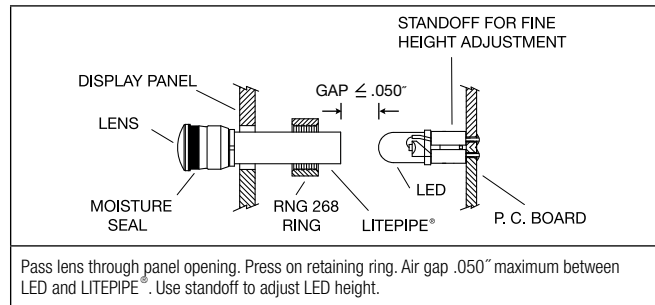

Pass lens through panel opening. Press on retaining ring. Air gap .050" maximum between LED and LITEPIPE®. Use standoff to adjust LED height.

ORDERING CODES

MODEL	LMS	XXX	RTP	COLOR
Assembly contains CLIPLITE® Lens, LITEPIPE®, and retainer.				RTP Red Transparent
				ATP Amber Transparent
				GTP Green Transparent
				BTP Blue Transparent
				YTP Yellow Transparent
				CTP Clear Transparent
				GLO White Translucent
	LITEPIPE®			
	LENGTH (INCHES)			
	033 (.330")	093 (.930")		
	053 (.530")	113 (1.13")		
	073 (.730")	133 (1.33")		

PANEL ASSEMBLY

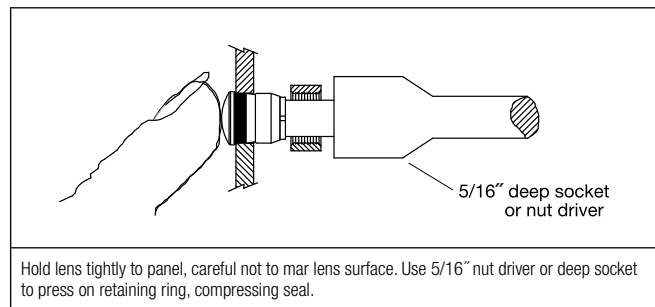

Hold lens tightly to panel, careful not to mar lens surface. Use 5/16" nut driver or deep socket to press on retaining ring, compressing seal.

OUTLINE DRAWING

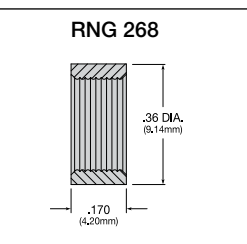
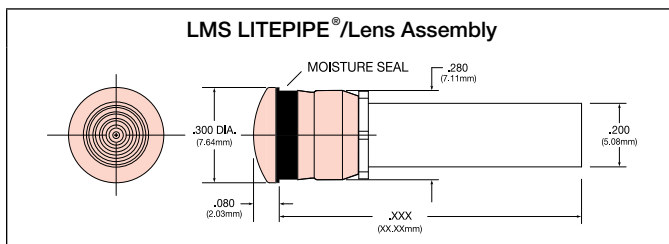

RECOMMENDED LEDs

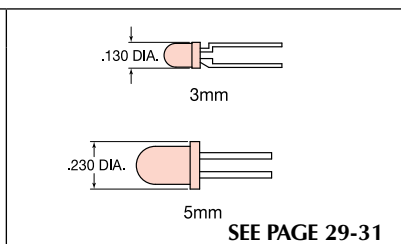

SEE PAGE 29-31

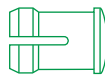

PANEL LENSES

PANEL LENS AND LITEPIPE® COMBINATION

SPECIFICATIONS

MATERIAL	LITEPIPE® - Acrylic (Optical grade) CLIPLITE® Lens - Polycarbonate Retaining Ring - Polypropylene (U.L. Listed Materials)
DESIGN	LITEPIPE® (3mm and 5mm) with annular ring and locking tab engages into the annular groove of VCC's low profile CLIPLITE® lens. The lens mounts the LITEPIPE® securely to the display panel and provides 180 degrees of viewing angle.
MOUNTING	LITEPIPE® 3mm - Mates with VCC's lenses model SMB 200 and SMQ 250. Panel mounting hole .171 (4.3mm) on 1/4" centers. Panel thickness 1/32" to 1/8". LITEPIPE® lengths from .200" to 1.200". LITEPIPE® 5mm - Mates with VCC's lens model CLB 300 and SQB 400. Panel mounting hole .250 (6.35mm) on 3/8" centers. Panel thickness 1/16" to 1/4". LITEPIPE® lengths from .360" to 1.360". For panels less than 3/16" use SPC 125 spacer.
STANDOFF	Use VCC's standoff to adjust the height of a standard LED above the PCB and maintain a maximum .050" clearance between the LITEPIPE® and LED. See STD Series data sheet on page 28.

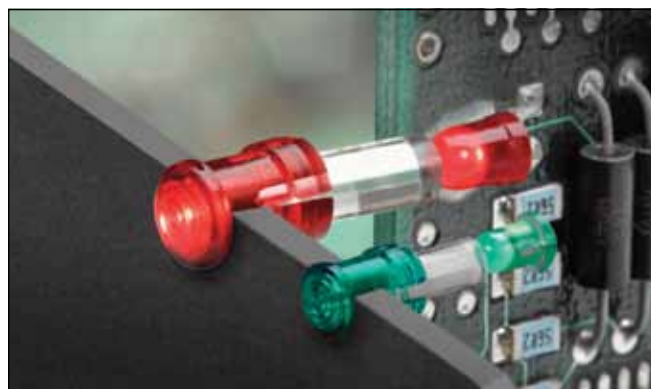

U.S. & Foreign Patents Issued.

VERSATILITY

The LITEPIPE® with CLIPLITE® lens easily provides a method for transmitting the light from PCB mounted LEDs to the front display panel. Both styles of LEDs, surface mount and standard packages, can be displayed in this manner.

BRIGHTNESS

The LITEPIPE® by itself has a limited angle of view. However, when used with the CLIPLITE® fresnel lens the light is dispersed over the entire lens surface producing 180 degrees of viewing.

APPLICATION

The LITEPIPE® with CLIPLITE® lens is available for use with both surface mount and standard packaged LEDs in 3mm and 5mm configurations. Because there is no physical connection between the LITEPIPE® and the PCB mounted LED, the circuit board can be installed or removed without disturbing the panel display.

INSTALLATION

The LITEPIPE® with CLIPLITE® lens is easy to install. Insert the lens through the panel opening and snap the LITEPIPE® into the lens. For added security in harsh environments, a retaining ring is available.

LITEPIPE® & SURFACE MOUNT LEDs

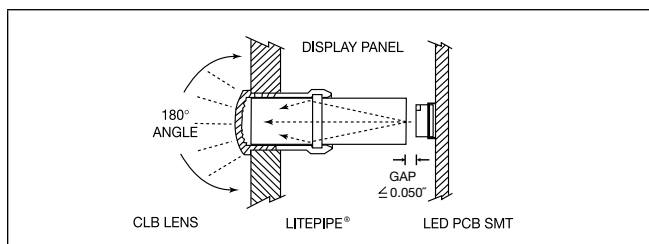

LITEPIPE® & RIGHT ANGLE LEDs

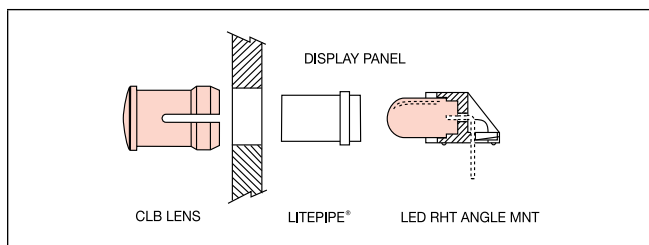

ORDERING CODE: LENS

CLB 300 RTP

MODEL	COLOR
SMB 200 (RND 3mm) Fresnel Lens	RTP Red Transparent
SMQ 250 (SQ 3mm) Fresnel Lens	ATP Amber Transparent
CLB 300 (RND 5mm) Fresnel Lens	GTP Green Transparent
SQB 400 (SQ 5mm) Fresnel Lens	BTP Blue Transparent
SPC 125 (Spacer for CLB 300 & SQB 400)	YTP Yellow Transparent
	CTP Clear Transparent
	GLO White Translucent

ORDERING CODE: LITEPIPE®

LSV XXX CTP

MODEL	PRODUCT CODE	COLOR
LSV (3mm)	LSV - CODE LENGTH (inches)	CTP CLEAR
	020 (.200") 040 (.400") 060 (.600")	
	080 (.800") 100 (1.00") 120 (1.20")	
	LCV - CODE LENGTH (inches)	
	036 (.360") 056 (.560") 076 (.760")	
	096 (.960") 116 (1.16") 136 (1.36")	

Custom Lengths upon request
Minimum order quantity may apply

OUTLINE DRAWING

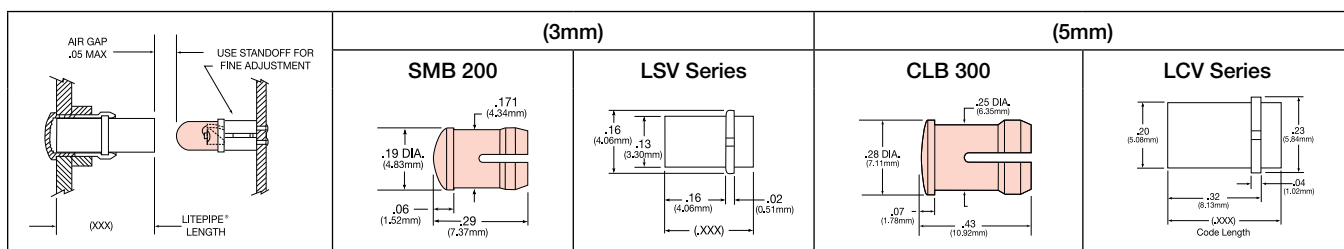

PANEL LENSES

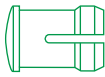

STANDARD LENS MOUNTS



U.S. & Foreign Patents Issued.

VISIBILITY

CLIPLITE® lenses produce up to 180 degrees of viewing angle using standard 3mm and 5mm LEDs.

BRIGHTNESS

The CLIPLITE® lens utilizes striated lines and fresnel rings to increase apparent brightness up to 125% and viewing angle up to 180 degrees with either diffused or nondiffused LEDs. A low profile lens without rings or lines is available for direct sunlight applications.

PROTECTION

CLIPLITE® lenses help prevent IC failures caused by electrostatic discharge (ESD). Simply walking across a carpet can generate 10,000 volts. Introduction of this ESD through an exposed panel mounted LED is capable of damaging or destroying a semiconductor. A CLIPLITE® mounted LED helps guard components from ESD up to 16kV while affording the LED physical protection.

INSTALLATION

CLIPLITE®, standard or low profile, requires no assembly tools; just snap into a panel opening and insert LED. Cost effective operation is complete in only 6 seconds.

SPECIFICATIONS

MATERIAL	Lens - Polycarbonate Spacer - Polypropylene (U.L. Listed Materials)
DESIGN	Standard and low profile lenses with fresnel rings and striated lines. CLR 301 Low Profile Lens is a plain end lens
MOUNTING	Mounts through front of panel. Mounting holes should be deburred but not chamfered. 3mm (SML 190, SMB 200) mounts in a $.171 \pm .002$ " (4.34mm) hole on 1/4" centers. Panel thickness for SML 190, 1/32" to 1/16"; SMB 200, 1/16" to 1/8"; 5mm (CLF 280, CLB 300, CLR 301) mounts in a $.250 \pm .002$ " (6.35mm) hole on 3/8" centers. Panel thickness for CLF 280, 1/16" to 1/8"; CLB 300 and CLR 301, 1/32" to 1/4"; for panels less than 3/16", use SPC 125 spacer.

SIMPLE TWO-STEP INSTALLATION

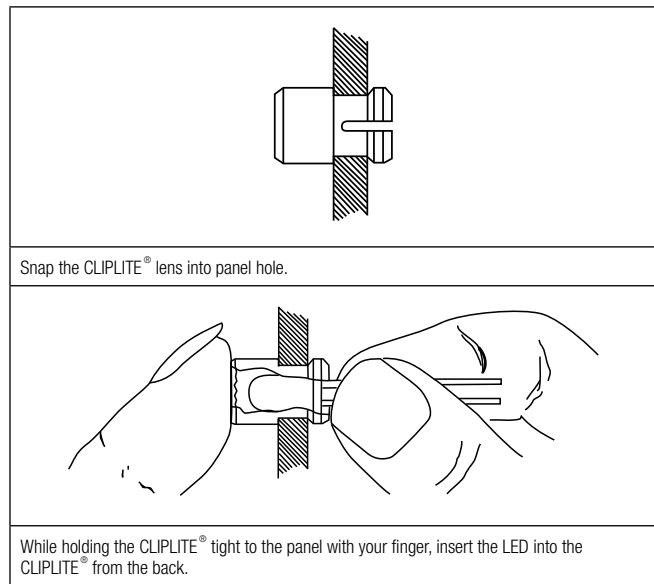

ORDERING CODES

CLF 280 RTP

MODEL

SML 190 (3mm) Standard Height Fresnel Lens
SMB 200 (3mm) Low Profile Fresnel Lens
CLF 280 (5mm) Standard Height Fresnel Lens
CLB 300 (5mm) Low Profile Fresnel Lens
CLR 301 (5mm) Low Profile Plain Fresnel Lens
SPC 125 (Spacer for CLB 300 and CLR 301)

COLOR

RTP Red Transparent
ATP Amber Transparent
GTP Green Transparent
BTP Blue Transparent
YTP Yellow Transparent
CTP Clear Transparent
GLO White Translucent

RECOMMENDED LEDs

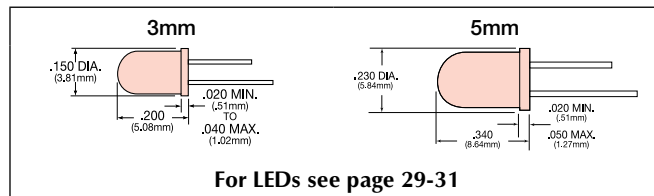

Currently offered standard for the SML 190, SMB 200, CLF 280, and CLB 300.
Inquires for any other lenses welcome

OUTLINE DRAWING

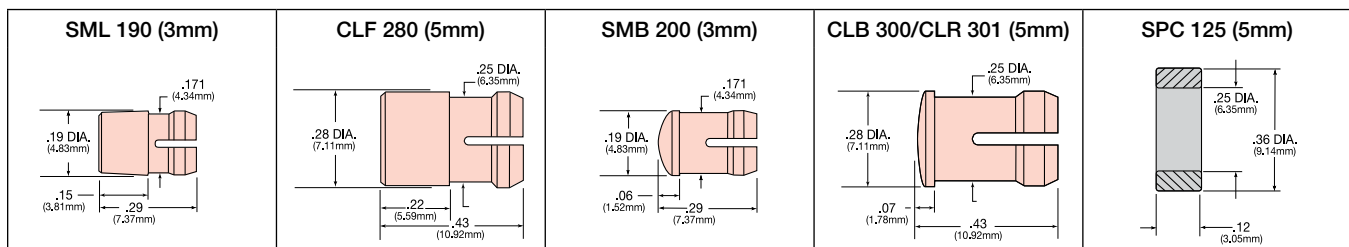

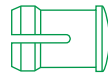

PANEL LENSES

STANDARD LENS MOUNTS

SPECIFICATIONS

MATERIAL	Lens - Polycarbonate Spacer - Polypropylene (U.L. Listed Materials)
MOUNTING	Mounts through front of panel. Mounting holes should be deburred but not chamfered. 3mm (SMQ 250) mounts in $.171" \pm .002"$ (4.34mm) round hole on $1/4"$ centers. Panel thickness from $1/16"$ to $1/8"$. 5mm (SQL 360) mounts in $.250" \pm .002"$ (6.35mm) square punched hole on $3/8"$ centers. Panel thickness from $1/16"$ to $1/8"$. 5mm (SQB 400) mounts in $.250" \pm .002"$ (6.35mm) round hole on $3/8"$ centers. Panel thickness from $1/32"$ to $1/4"$; for panels less than $3/16"$, use SPC 125 spacer.



U.S. & Foreign Patents Issued.

EASY TWO-STEP INSTALLATION

Snap CUBELITE[®] lens into a $1/4"$ panel hole.

While holding the CUBELITE[®] lens tight to the panel with your finger, insert the LED into the CUBELITE[®] lens from the back.

RECOMMENDED LEDs

3mm

$.150$ DIA. (3.81mm)
 $.200$ (5.08mm)
 $.020$ MIN. (.51mm)
 $.040$ MAX. (1.02mm)

5mm

$.230$ DIA. (5.84mm)
 $.340$ (8.64mm)
 $.020$ MIN. (.51mm)
 $.050$ MAX. (1.27mm)

SEE PAGE 29-31

VISIBILITY

CLIPLITE[®] CUBELITE[®] standard square lens offers 20% more viewing area over a round indicator light. The CUBELITE[®] lenses' unique patented features include striated lines and fresnel rings permitting up to 180 degrees viewing angle with any stock 3mm or 5mm LED.

DESIGN

CUBELITE[®] standard lens mounts in a square hole. Its uniform lens thickness produces an even light pattern with no dark corners. CUBELITE[®] low profile square lens mounts in a round hole. This lens has a $.070"$ maximum panel height and still produces a 180 degree viewing angle. The design of the CUBELITE[®] lens permits use of either diffused or nondiffused LEDs.

PROTECTION

CUBELITE[®] helps prevent IC failures caused by electrostatic discharge (ESD). Simply walking across a carpet can generate 10,000 volts. Introduction of this ESD through an exposed panel mounted LED is capable of damaging or destroying a semiconductor. A CUBELITE[®] mounted LED helps guard components from ESD up to 16,000 volts as well as affording the LED physical protection.

INSTALLATION

CUBELITE[®] standard or low profile, requires no assembly tools; just snap into a panel opening and insert LED. Cost effective operation is complete in only 6 seconds.

ORDERING CODES

SQL 360 RTP

MODEL

SMQ 250 (3mm) Low Profile Fresnel Lens
 SQB 400 (5mm) Low Profile Fresnel Lens
 SQL 360 (5mm) Standard Height Fresnel Lens
 SPC 125 (Spacer for SQB 400)

COLOR

RTP Red Transparent
 ATP Amber Transparent
 GTP Green Transparent
 BTP Blue Transparent
 YTP Yellow Transparent
 CTP Clear Transparent

OUTLINE DRAWING

SMQ 250 (3mm)

$.171$ DIA. (4.34mm)
 $.19$ SQ. (4.83mm)
 $.06$ (1.52mm)
 $.29$ (7.37mm)

SQB 400 (5mm)

$.25$ DIA. (6.35mm)
 $.18$ SQ. (4.57mm)
 $.07$ (1.78mm)
 $.43$ (10.92mm)

SQL 360 (5mm)

$.25$ SQ. (6.35mm)
 $.28$ SQ. (7.11mm)
 $.22$ (5.59mm)
 $.43$ (10.92mm)

SPC 125 (5mm)

$.25$ DIA. (6.35mm)
 $.36$ DIA. (9.14mm)
 $.12$ (3.05mm)

PANEL LENSES

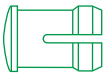

LOW PROFILE LENS MOUNTS



U.S. & Foreign Patents Issued.

VERSATILITY

CLIPLITE® lenses, installed in a display panel, are used with PCB mounted LEDs. Lenses remain attached to the display or panel door while the LEDs are fixed to the PCB. The lenses are ideal when used together with the CONXRITE® connector assembly.

BRIGHTNESS

CLIPLITE® lenses utilize fresnel rings to increase apparent brightness and viewing angle up to 180 degrees with either diffused or nondiffused LEDs.

PROTECTION

CLIPLITE® lenses help prevent IC failures caused by electrostatic discharge (ESD). Introduction of ESD through an exposed panel mounted LED is capable of damaging or destroying a semiconductor. A CLIPLITE® mounted LED helps guard components from ESD up to 16KV while affording the LED physical protection.

INSTALLATION

CLIPLITE® is inserted through panel opening, retaining ring pressed into place. PCB mounted LEDs slide into lenses when the panel cover is closed or the PCB card is inserted into the case.

SPECIFICATIONS

MATERIAL	Lens - Polycarbonate Retaining Ring - Polypropylene (U.L. Listed Materials)
DESIGN	Low profile lenses CMC 313 plain diffused, CMC 321, CML 325 & SMC 170 with fresnel rings. CMC 323 & CML 327 plain end lens.
MOUNTING	Mounts through front of panel, Retaining ring secures the lens in place. 5mm CMC & CML series mount in a .281" (7.2mm) hole on 3/8" centers, Panel thickness 1/32" to 1/4". 3mm (SMC 170) mounts in a .171" (4.4mm) hole on 1/4" centers. Panel thickness 1/32" to 3/32". For add security use RNG 132 (3mm) or RNG 268 (5mm).

PANEL MOUNTED LENS WITH PCB MOUNTED LED

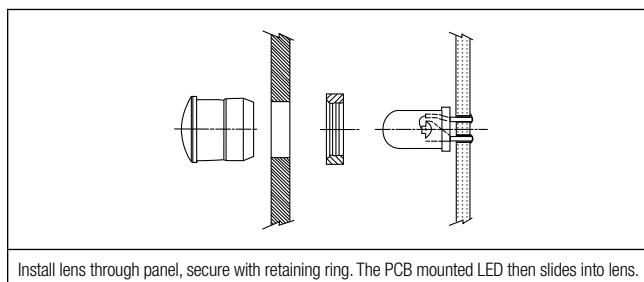

Install lens through panel, secure with retaining ring. The PCB mounted LED then slides into lens.

PANEL MOUNTED LENS WITH CONXRITE CONNECTOR

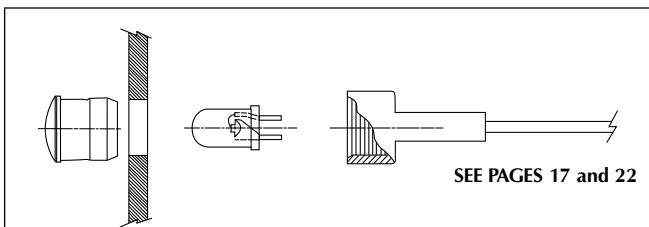

SEE PAGES 17 and 22

Install lens through panel, insert LED into connector, press connector onto lens to complete installation.

RECOMMENDED LEDs

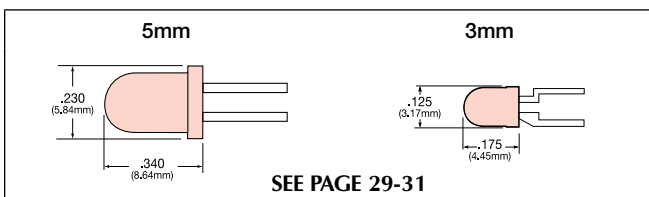

SEE PAGE 29-31

ORDERING CODES

MODEL	CMC 321	RTP	COLOR
SMC 170 (3mm) Fresnel Low Profile Lens			RTP Red Transparent
CMC 313 (5mm) Plain Diffused Lens			ATP Amber Transparent
CMC 321 (5mm) Fresnel Low Profile Lens			GTP Green Transparent
* CMC 323 (5mm) Plain End Lens			YTP Yellow Transparent
* CML 325 (5mm) Fresnel Low Profile Lens			BTP Blue Transparent
* CML 327 (5mm) Plain End Lens			CTP Clear Transparent
RNG 132 (3mm) Retaining Ring			
RNG 268 (5mm) Retaining Ring			

* Denotes Clear only

LENS STYLES

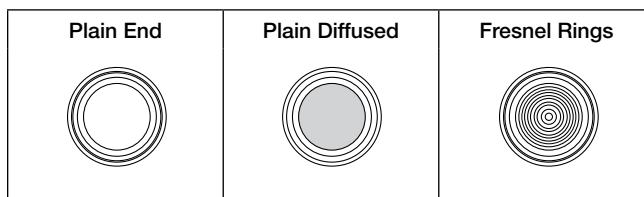

OUTLINE DRAWING

CMC 313/CMC 321 CMC 323 (5mm)	CML 325/CML 327 (5mm)	RNG 268 (5mm)	SMC 170 (3mm)	RNG 132 (3mm)

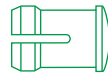

PANEL LENSES

MOISTURE SEALED LENS MOUNTS

SPECIFICATIONS

MATERIAL	Lens - Polycarbonate Ring - Polypropylene, Seal - TPE (U.L. Listed Materials)
DESIGN	Low profile lenses with moisture seal.
TESTING	Environmental testing performed by Consolidated Labs, Inc. for moisture sealing, shock, vibration and standard operating temperatures. Meets NEMA 4 standards.
MOUNTING	Mounts through front of panel, compression of the seal is accomplished by pressing the retaining ring or CONXRITE® connector in place. 5mm (CMS 322), mounts in a 9/32" (7.2mm) hole on 3/8" centers. Panel thickness 1/32" to 1/8". Hole should be deburred but not chamfered. See specs. on page 17 for use with CNX connectors. For add security use RNG 268.



U.S. & Foreign Patents Issued.

PANEL MOUNTED LENS WITH PCB MOUNTED LED

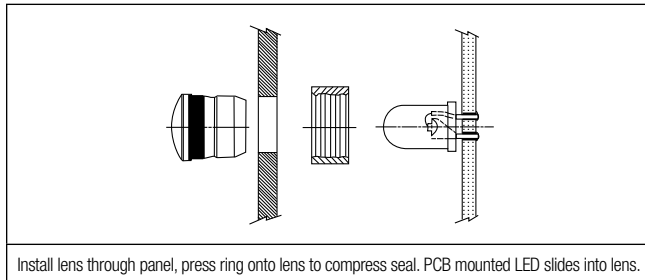

Install lens through panel, press ring onto lens to compress seal. PCB mounted LED slides into lens.

VERSATILITY

CLIPLITE® moisture sealed lenses, installed in a moisture seal effective against splash and drip conditions. The lens can be used with either circuit board mounted or panel mounted LEDs. For PCB mounting applications the lens remains attached to the display or panel door while the LEDs are fixed to the PCB. The lens is ideal when used with the CONXRITE® connector for mounting the LED directly to the display panel.

BRIGHTNESS

CLIPLITE® lenses utilize fresnel rings to increase apparent brightness and viewing angle up to 180 degrees with either diffused or nondiffused LEDs.

PROTECTION

CLIPLITE® tests show it is an effective moisture seal in splash and drip conditions. In addition, the lens helps prevent IC failures caused by electrostatic discharge (ESD). A CLIPLITE® mounted LED guards components from ESD up to 16 kV while affording the LED physical protection.

INSTALLATION

The CLIPLITE® lens is inserted through panel opening, retaining ring is then pressed into place compressing the seal. PCB mounted LEDs slide easily into lens allowing simple insertion or removal of the PCB. Panel mounting of the LED is accomplished with the CONXRITE® connector which also serves to compress the moisture sealing ring.

ORDERING CODES

CMS 322 RTP

MODEL

CMS 322 (5mm) Low Profile Fresnel Lens with moisture seal NEMA 4
RNG 268 (5mm) Retaining Ring

COLOR

RTP Red Transparent
ATP Amber Transparent
GTP Green Transparent
BTP Blue Transparent
YTP Yellow Transparent
CTP Clear Transparent
GLO White Translucent

PANEL MOUNTED LENS WITH CONXRITE® CONNECTOR

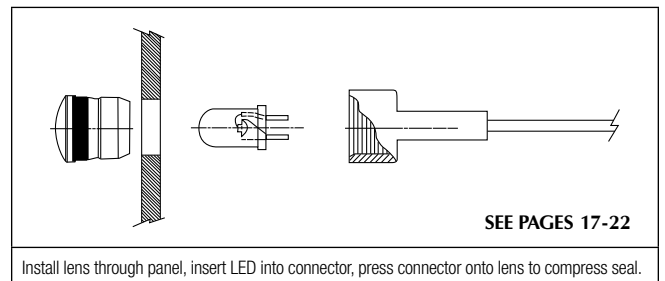

SEE PAGES 17-22

Install lens through panel, insert LED into connector, press connector onto lens to compress seal.

OUTLINE DRAWING

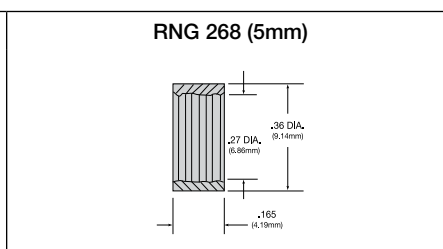
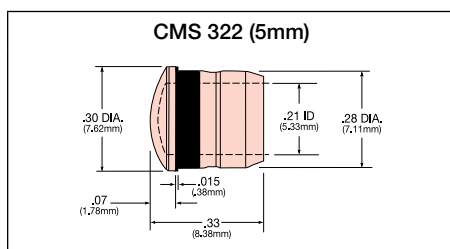

RECOMMENDED LEDs

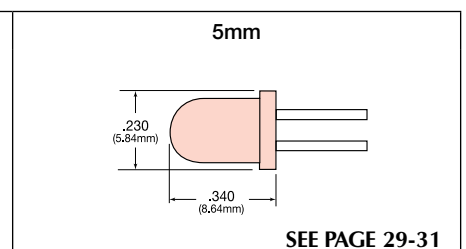

SEE PAGE 29-31

PANEL LENSES

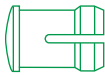

THREADED LENS MOUNTS



U.S. & Foreign Patents Issued.

VERSATILITY

CLIPLITE® lenses provide a method of viewing PCB mounted LEDs on a display panel. Designed to accommodate 5mm through-hole LEDs. Permits LED viewing angles of up to 180 degrees. Lenses are available in six colors.

BRIGHTNESS

CLIPLITE® lenses enhance the direct viewing of PCB mounted LEDs. Mono, multi-color, infrared, and photo detection devices can be displayed in this manner. LED brightness levels can range from 20 to 40,000mcd.

APPLICATION

CLIPLITE® lenses permit the panel display of PCB mounted LED without its physical attachment to front panel. Properly installed, the assembly exceeds NEMA 6P for water, ice and dust conditions. Additionally tested for U.V., solar, temperature cycling, shock and vibration. Also provides circuit protection from ESD.

INSTALLATION

CLIPLITE® 5mm lenses are easily installed. Simply slip lens through a 5/16" panel opening, slide lock washer onto lens barrel and twist retaining ring. PCB mounted LED can then slide in and out of the lens without physical attachment to display panel. If overtightened, retaining ring is designed to slip back into previous thread. Secure by retightening ring.

SPECIFICATIONS

MATERIAL	Lens - Polycarbonate Lock washer - FH Steel, Nickel plate Retaining ring - Thermoplastic U.L. 94 V0 Rated Seal - EPDM
DESIGN	CMC 441 / CMC 443 5mm low profile lens with fresnel rings. CMS 442 / CMS 444 5mm low profile plain lens.
MOUNTING	Mounts through a 5/16" (80mm) hole on 1/2" center. Panel thickness 1/32" to 1/8". Mounts through front of panel. Retaining pins secures the assembly panel.
TEST DATA	Assembly tested for: Temperature cycle -40°C to +105°C, Water, Ice, Shock/vibration up to 6g at 2000Hz, Solar & UV. Tests conducted by Consolidated Laboratories.

EASY THREE STEP PANEL ASSEMBLY

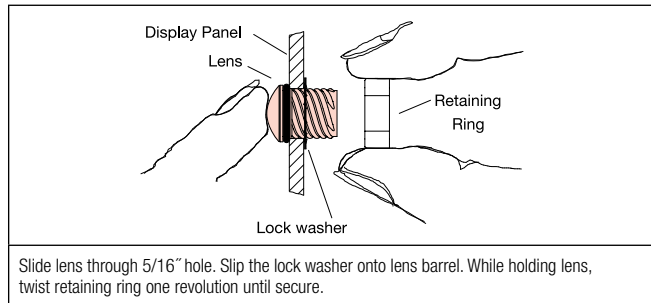

LENS ASSEMBLY WITH PCB MOUNTED LEDs

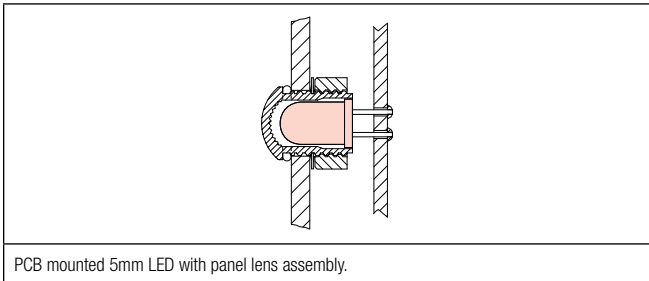

ORDERING CODES

CMC 441 RTP	
MODEL	COLOR
CMC 441 Standard Threaded 5mm Fresnel Lens	RTP Red Transparent
CMC 442 Water Tight Threaded 5mm Fresnel Lens	ATP Amber Transparent
CMC 443 Standard Threaded 5MM Plain Lens	GTP Green Transparent
CMS 444 Watertight Threaded 5MM Plain Lens	BTP Blue Transparent
CMC 441/CMC 443 ASSEMBLY CONTAINS	YTP Yellow Transparent
Lens	CTP Clear Transparent
Lock washer	
Retaining ring	
CMS 442/CMS 444 ASSEMBLY CONTAINS	
Lens w/Seal (Exceeds NEMA 6P)	
Lock washer	
Retaining ring	

OUTLINE DRAWING

CMC 441/CMC 443 (Assembly) STANDARD LENS w/Lockwasher & Retainer 	CMS 442/CMC 444 (Assembly) WATER TIGHT SEAL w/Lockwasher & Retainer 	LOCK WASHER 	RETAINING RING 	
				SEE PAGE 30-31

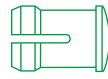

PANEL LENSES

THREADED LENS MOUNTS

SPECIFICATIONS

MATERIAL	Lens - Polycarbonate Lock washer - FH Steel, Nickel plate Retaining ring - Thermoplastic U.L. 94 V0 Rated Seal - EPDM
DESIGN	10mm low profile lens with fresnel rings.
MOUNTING	Mounts through front of panel. Retaining ring secures the assembly to panel. HMC 461 & HMS 462 mounts through a 9/16" (14.3mm) hole on 3/4" centers. Panel thickness 1/32" to 3/16".
TEST DATA	Assembly tested for: Temperature cycle -40°C to +105°C, Water, Ice, Shock/vibration up to 6g at 2000Hz, Solar & UV. Tests conducted by Consolidated Laboratories.



U.S. & Foreign Patents Issued.

EASY THREE STEP PANEL ASSEMBLY

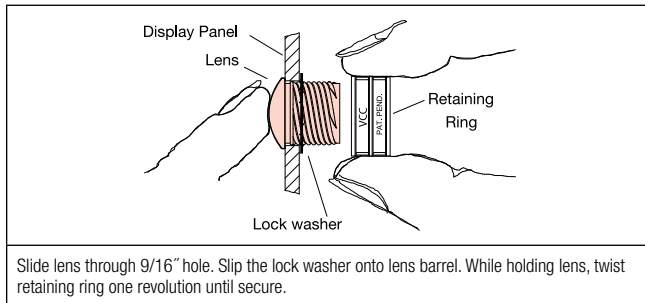

VERSATILITY

CLIPLITE® lenses provide a method of viewing PCB mounted LEDs on a display panel. Designed to accommodate either Hi-flux or 10mm LEDs. Permits LED viewing angles of up to 180 degrees. Lenses are available in six colors.

BRIGHTNESS

CLIPLITE® lenses enhance the direct viewing of PCB mounted LEDs. Mono, multi-color, infrared, and photo detection devices can be displayed in this manner. LED brightness levels can range from 20 to 40,000mcd.

APPLICATION

CLIPLITE® lenses permit the panel display of PCB mounted LED without its physical attachment to front panel. Properly installed, the assembly exceeds NEMA 6P for water, ice and dust conditions. Additionally tested for U.V., solar, temperature cycling, shock and vibration. Also provides circuit protection from ESD.

INSTALLATION

CLIPLITE® 10mm lenses are easily installed. Simply slip lens through a 9/16" panel opening, slide lock washer onto lens barrel and twist on retaining ring. PCB mounted LED can then slide in and out of the lens without physical attachment to display panel. If overtightened, retaining ring is designed to slip back into previous thread. Secure by retightening ring.

ORDERING CODES

HMC 461 RTP

MODEL

HMC 461 Standard Threaded 10mm Fresnel Lens
 HMS 462 Water Tight Threaded 10mm Fresnel Lens

HMC 461 ASSEMBLY CONTAINS

Lens
 Lock washer
 Retaining ring

HMS 462 ASSEMBLY CONTAINS

Lens w/Seal (exceeds NEMA 6P)
 Lock washer
 Retaining ring

COLOR

RTP Red Transparent
 ATP Amber Transparent
 GTP Green Transparent
 BTP Blue Transparent
 YTP Yellow Transparent
 CTP Clear Transparent

LENS ASSEMBLY WITH PCB MOUNTED LEDs

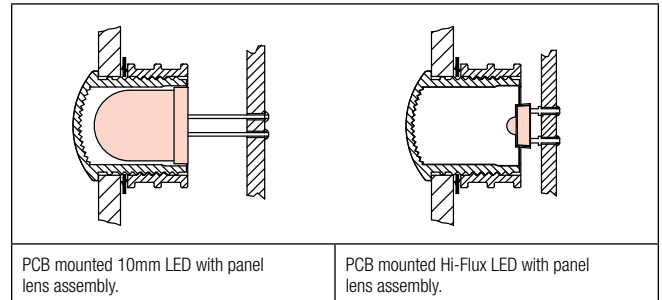

OUTLINE DRAWING

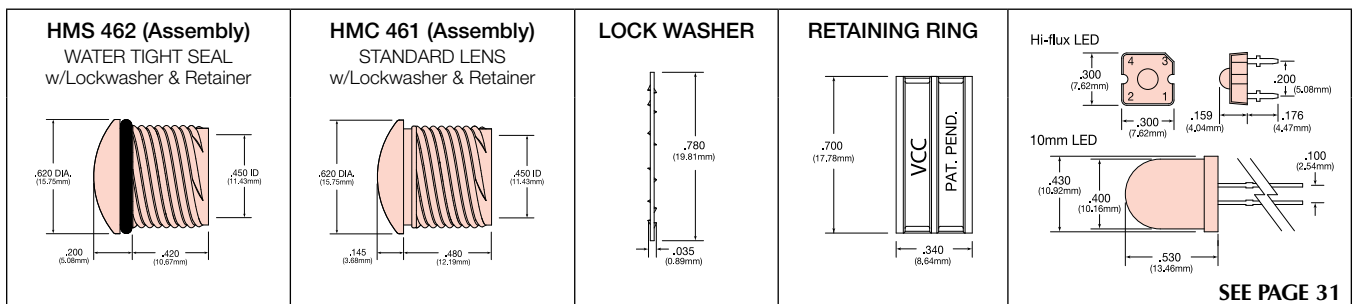

SEE PAGE 31

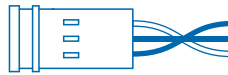

PANEL MOUNT ASSEMBLIES



U.S. & Foreign Patents Issued.

CONXRITE®

This modular cabling assembly is designed for use in the electrical connection of panel mounted LEDs to printed circuit boards. This plug-in system eliminates many of the problems associated with wiring display panel mounted LEDs.

APPLICATIONS

Designed to make quick and easy plug-in connections between panel mounted LEDs and the PCB. The modular concept of panel and header housings along with different wire lengths offer a cost reducing solution to cabling problems.

VERSATILITY

Multiple panel mounted LED devices can be connected to PCB mounted headers. A uniquely designed three finger box terminal mates with leads .017" in diameter to .025" square. Cables are available from standard stock in 4", 6", 8", 12", 18" and 24" lengths.

INSTALLATION

Modular cabling systems simplify the electrical connection from panel to PCB and eliminate the need for assembly tools. Cost savings from the discontinuing of soldering and terminal crimping operations are substantial. When properly installed the assembly is able to withstand up to 6g's at 2000Hz.

SPECIFICATIONS

MATERIAL	Panel Connector Socket & Ring - Thermoplastic Header Connector - Thermoplastic (UL listed materials) Terminals - Phosphor bronze, tin plated Wire - 24 AWG, 7 strand copper, insulated
ELECTRICAL	Terminal - 3 amp continuous service Unique three-finger design mates to round, square or rectangular leads .017" to .025".
MOUNTING	Panel Connector 3mm - Mates with SMC 130 & 170. Panel Connector 5mm - Mates with CMC 285, 313, 321, 323, CMS 322, CML 325 and 327. See data sheets pages 13, 14 & 25. Panel Thickness - See page 18. All holes deburred but not chamfered. LED lead trimming - See page 18. Hole Size - SMC series 11/64" (4.37mm). CMC, CMS & CML series 9/32" (7.14mm). Header Connector - Mates with VCC positive locking header 450 series. Also mates with standard and friction header .025" pins on .100" centers.

COMPLETED ASSEMBLY

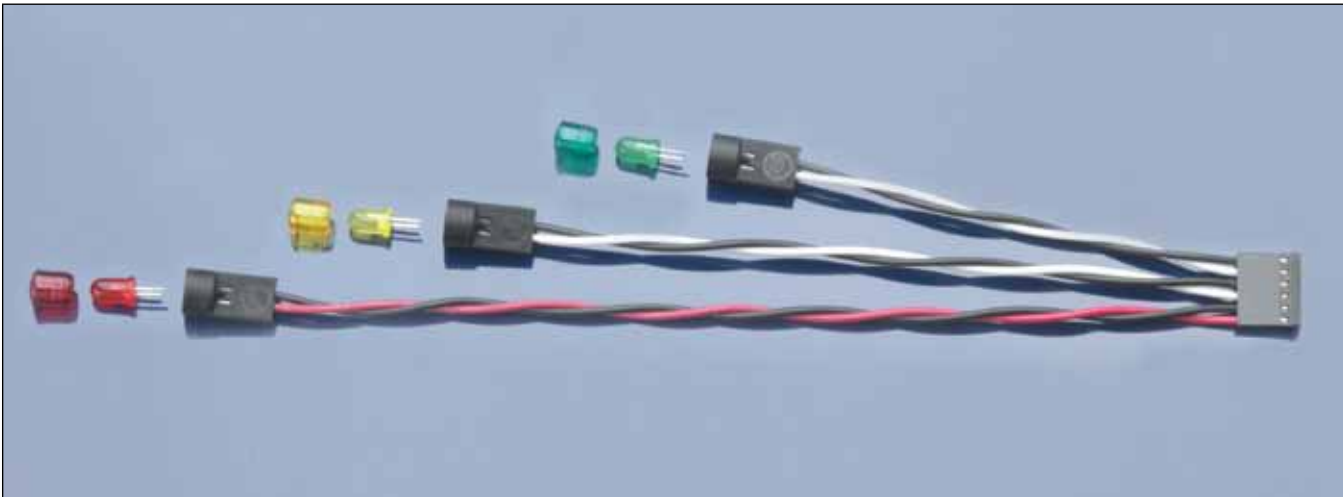

RECOMMENDED LEDs

<p>3mm Bi-Lead Use "B" Connector</p>	<p>5mm Bi-Lead Use "C" Connector</p>	<p>5mm Tri-Lead Use "D" Connector</p>	<p>5mm Flangeless Use "K" Connector</p>
---	---	--	--

SEE PAGE 29-31

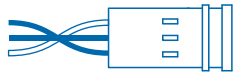

INTERCONNECTORS

PANEL MOUNT ASSEMBLIES

3mm BI-LEAD ("B" CONNECTOR)

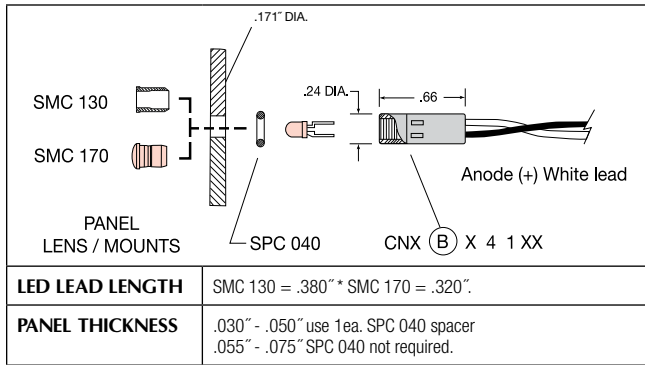

5mm BI-LEAD ("C" CONNECTOR)

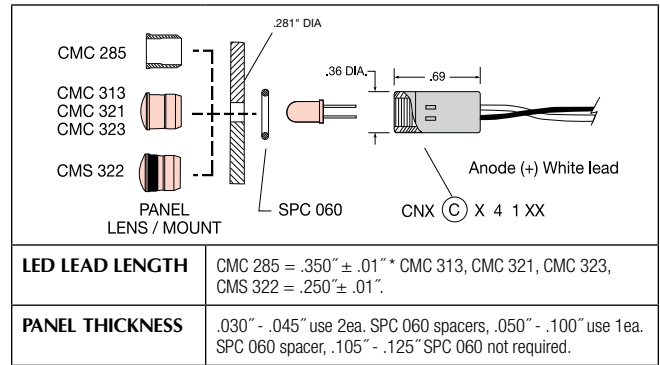

5mm TRI-LEAD ("D" CONNECTOR)

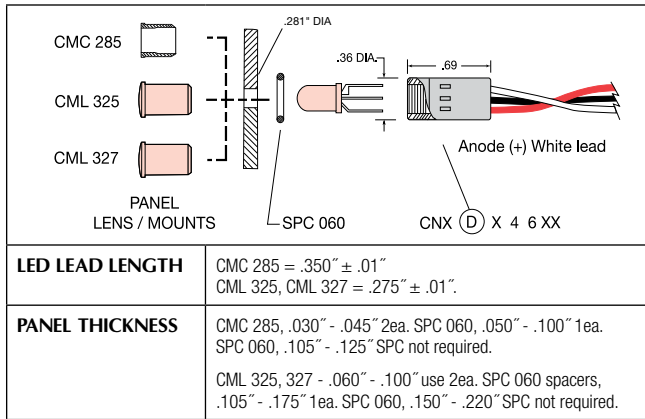

5mm FLANGELESS ("K" CONNECTOR)

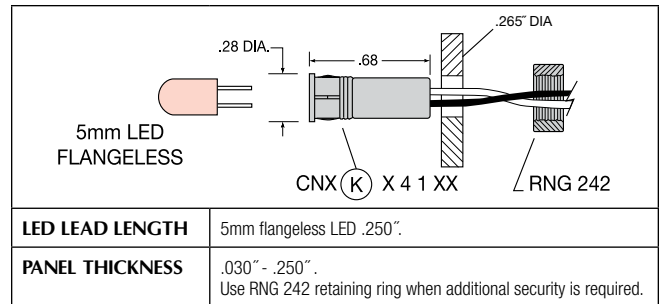

PLAIN & LOCKING HEADER

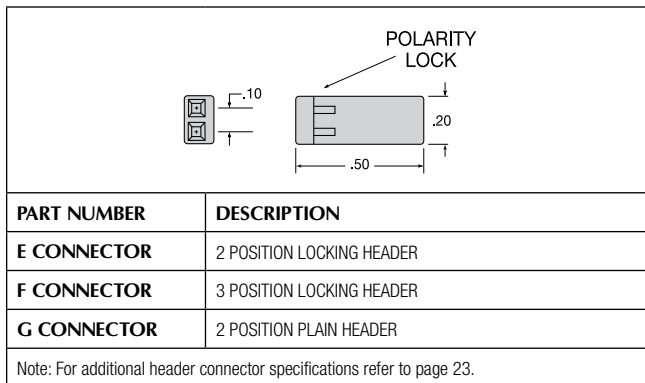

ORDERING CODES

CNX C E 4 1 04

TERMINATION

WIRE SIZE

WIRE COLOR

WIRE LENGTH

PANEL (LED) SIDE	PC BOARD SIDE	STANDARD	WIRE COLOR	WIRE LENGTH
B 3mm Panel Connector 2 Lead	E Locking Hdr Connector 2 Lead	4 24 AWG	1 - WHT - BLK	04 4 INCHES
C 5mm Panel Connector 2 Lead	F Locking Hdr Connector 3 Lead		2 - RED - BLK	06 6 INCHES
D 5mm Panel Connector 3 Lead	G Plain Hdr Connector 2 Lead		6 - WHT - BLK - RED	08 8 INCHES
K Panel Socket 2 Lead	X Wire Leads - Stripped Ends			12 12 INCHES
				18 18 INCHES
				24 24 INCHES

ADDITIONAL OPTIONS AVAILABLE

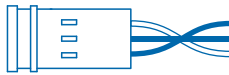

PANEL MOUNT ASSEMBLIES



U.S. & Foreign Patents Issued.

VERSATILITY

CONXRITE® cabling system simplifies display panel to power source interface. Options include: LED - 5mm, 10mm Hi-Flux. Color - mono, bi-color, tri-color, RGB. Wire - size, color, length. Wire termination - header/connector, positive locking, single, dual row. Terminals - ring or spade style.

BRIGHTNESS

CONXRITE® assemblies enhance LED apparent brightness as well as the viewing angle to 180°. Visible, infrared, and photo detection devices can be displayed in this manner. Illumination can range from 20 to 20,000mcd.

APPLICATION

CONXRITE® LED cable assemblies are used in consumer products, communications, industrial, automotive, heavy equipment, security systems, interior and exterior projects. Tested for temperature cycling, UV, solar, shock, vibration. Sealed version exceeds NEMA 6P for dust, water and ice. Also provides ESD circuit protection.

INSTALLATION

CONXRITE® assemblies "plug and play" approach simplifies cable installation. Slip lens through panel opening, slide lock washer over lens barrel, connector secures to lens with a half turn.

SPECIFICATIONS

MATERIAL	Lens - Polycarbonate, (UL Listed Material) Connector - Thermoplastic (white), U.L. 94 V0 Moisture seal - EPDM Lock washer - Steel, nickel plate Terminals - Phosphor bronze, tin plate Wire - U.L.1007/1569, 24 AWG stranded
ELECTRICAL	Terminal - 3 amp continuous service. Mates with round, square, rectangular leads .017" to .030".
MOUNTING	CMC / HMC series lens for standard dry applications. CMS / HMS series lens for dust and wet conditions. CMC 441 / CMS 442 lens mount through a 5/16" (8mm) opening on 1/2" centers. Panel thickness 1/32" to 1/8". HMC 461 and HMS 462 lens mount through 9/16" (14mm) opening on 3/4" centers. Panel thickness 1/32" to 3/16". Wire termination - VCC 450 series single or dual row positive locking header connectors, stripped leads. Contact factory for other termination options.
TEST DATA	Assembly tested for Shock/vibration - 6g's at 2000hz, Temperature - 40° to + 105°C, Solar and UV. Meets NEMA 6P, for water, ice and dust. Test conducted by Consolidated Laboratories Inc.
LEDs	5mm LEDs bi-lead, trim leads to .250" ± .010" (6.35mm). 10mm LEDs bi-lead, trim leads to .300" ± .010" (7.62mm). Hi-flux LEDs 4 leads trimming not required. Contact factory for additional wire and LED options. Tri-lead and six lead devices.

LENS AND CONNECTOR ASSEMBLIES

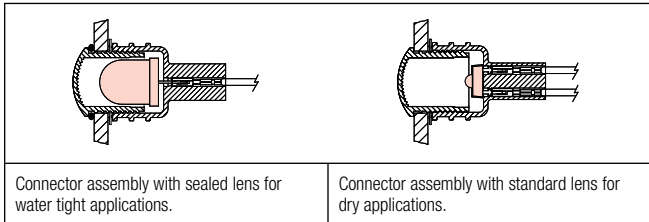

Connector assembly with sealed lens for water tight applications.

Connector assembly with standard lens for dry applications.

EASY THREE STEP PANEL ASSEMBLY

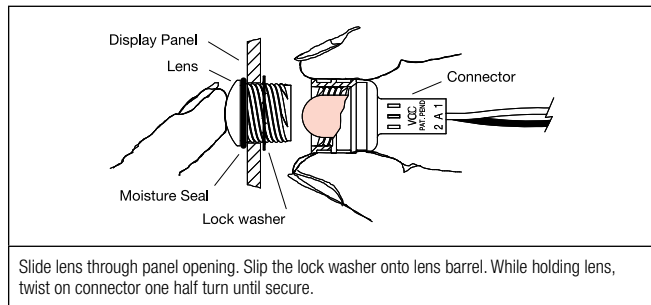

Slide lens through panel opening. Slip the lock washer onto lens barrel. While holding lens, twist on connector one half turn until secure.

OUTLINE DRAWING

RECOMMENDED LEDs

<p>CMC 441 / CMS 442 LENS ASSEMBLY</p>	<p>LOCK WASHER</p>	<p>CNX 440 CONNECTOR ASSEMBLY</p>	<p>SEE PAGE 29-31</p>
<p>HMC 461 / HMS 462 LENS ASSEMBLY</p>	<p>LOCK WASHER</p>	<p>CNX 460 CONNECTOR ASSEMBLY</p>	<p>SEE PAGE 31</p>

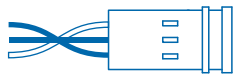

CNX 440 STANDARD ASSEMBLIES (5mm)

<p>CMC 441 (STANDARD) CMS 442 (WATER TIGHT) Display Panel Lock washer 5mm LED Socket (2 leads)</p>	<p>CMC 441 (STANDARD) CMS 442 (WATER TIGHT) Display Panel Lock washer 5mm LED Socket (3 leads)</p>
<p>LED 5mm bi-lead - trim lead length .250" ± .01" (5.58mm) Panel Thickness - .032" to .125"; Panel Hole: .312" (8.0mm) Recommended LEDs - 5mm bi-lead, 5mm tri-lead (tri-color) and 5mm six-lead (RGB)</p>	<p>LED 5mm tri-lead - leads custom formed by VCC Panel Thickness - .032" to .125"; Panel Hole: .312" (8.0mm)</p>

CNX 460 STANDARD ASSEMBLIES (10mm)

<p>HMC 461 (STANDARD) HMS 462 (WATER TIGHT) Display Panel Lock washer 10mm LED Socket (2 or 3 leads)</p>	<p>HMC 461 (STANDARD) HMS 462 (WATER TIGHT) Display Panel Lock washer Hi-Flux LED Socket (4 leads)</p>
<p>LED 10mm bi-lead - trim lead length .300" ± .01" (8.13mm) Panel Thickness - .032" to .187"; Panel Hole: .562" (14.0mm) Recommended LEDs - 10mm bi-lead, 10mm tri-lead (bi-color), 10mm six lead (RGB) and Hi-Flux four-lead ultra bright.</p>	<p>LED Hi-Flux lead length: Install as is. Panel thickness - .032" to .187"; Panel Hole: .562" (14.0mm).</p>

HEADER CONNECTORS AND HEADERS

<p>E 02 CONNECTOR LOCKING HEADER</p>	<p>D 04 CONNECTOR LOCKING HEADER</p>
<p>Single Row on .100" centers</p>	<p>Dual Row on .100" x .100" centers</p>

ORDERING CODES

CNX 440 E02 4 1 12				
CONNECTOR STYLE	TERMINATION	WIRE SIZE	WIRE COLOR	WIRE LENGTH
CNX 440 for 5mm LED CNX 460 for 10mm LED See above for available lens options (Sold Separately)	X = STRIPPED END E = SINGLE ROW D = DUAL ROW 02 = 2 Wires 03 = 3 Wires 04 = 4 Wires	STANDARD 4 24 AWG	1 - WHT - BLK 2 - RED - BLK 6 - WHT - BLK - RED 0 - WHT - BLK - RED - GRN	04 4 INCHES 06 6 INCHES 08 8 INCHES 12 12 INCHES 18 18 INCHES 24 24 INCHES

ADDITIONAL OPTIONS AVAILABLE

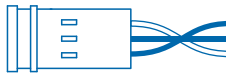

PANEL MOUNT ASSEMBLIES



U.S. & Foreign Patents Issued.

VERSATILITY

The CNX 480 is offered in black or clear anodized aluminum bodies. Lens and LED color combinations include red, green, and white. Custom body and lens/LED color inquiries are welcome.

BRIGHTNESS

High intensity LEDs and our wide-angle viewing lens deliver unmatched/enhanced viewing in direct sunlight, making this device perfect for virtually any signaling or indicator application.

APPLICATION

The CNX 480 panel mounted LED indicator was designed for use in outdoor and harsh environments. It has a low profile and a body composed of rugged, anodized aluminum, making it virtually indestructible. The NEMA 4 Rating and fully potted manufacturing process assure the CNX 480 can withstand prolonged exposure to wind, dust, rain and sleet. In addition, this assembly can endure being exposed to disinfectants and sterilization materials without material breakdown.

INSTALLATION

Installation of the CNX 480 is accomplished by passing the device through the panel opening and then adding a lock washer and threaded nut onto the back. While the long life of this device limits replacement requirements, when replacement is required, it is an easy and quick process.

SPECIFICATIONS

MATERIAL	Lens - Polycarbonate UL Rating 94-V2 Body - Aluminum Alloy Nut - Alluminum Alloy Lock washer - Steel, zinc plated UL Rating 94-V0 Terminals - Wire - UL 1007/1569, 24awg stranded
ELECTRICAL	Terminal -
MOUNTING	Hole: .399" +/- .004 Panel thickness: .059" MIN to .320" MAX
TEST DATA	Assembly meets NEMA 4 for water, ice and dust. Additional tests, temperature cycle -40° to +80°C, shock to 6gs, vibration to 2000hz, solar and UV. Testing conducted by Consolidated Laboratories, Covina, CA.

EASY INSTALLATION

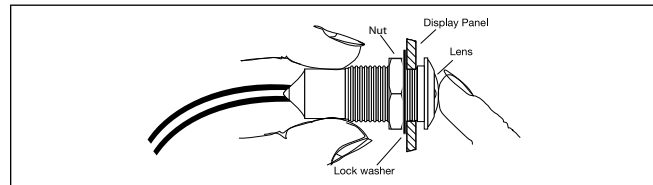

ORDERING CODES

CNX 480 X XXX XX

SOCKET BODY	LENS COLOR**	WIRE LENGTH CODE
BLACK	RTP RED TRANSPARENT	12 12.0" [305mm]
CLEAR	GTP GREEN TRANSPARENT	24 24.0" [605mm]
	CTP CLEAR TRANSPARENT	
	BTP BLUE TRANSPARENT	
	YTP YELLOW TRANSPARENT	

ADDITIONAL OPTIONS AVAILABLE

LED OUTPUT

LED COLORS**	TYP INTENSITY, mcd	CURRENT, mA
RED	245-345	20
GREEN	345-485	20
WHITE	3500-4900	20
BLUE	950-1300	20
YELLOW	280-380	20

* CALL FACTORY FOR ADDITIONAL OPTIONS

** LED COLORS SAME AS THE LENS COLORS. EX: A RED LENS COMES WITH A RED LED

OUTLINE DRAWING

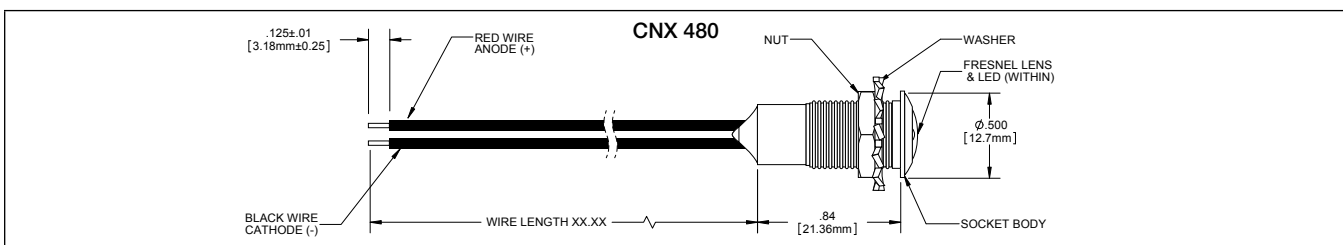

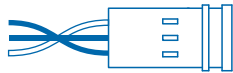

INTERCONNECTORS

PANEL MOUNT ASSEMBLIES

SPECIFICATIONS

MATERIAL	Lens - Polycarbonate Connector - Thermoplastic (U.L. Listed Materials) Moisture seal - EPDM Lock washer - Steel, nickel plate Terminals - Phosphor bronze, tin plate Wire - U.L. 1007/1569, 24 AWG stranded
ELECTRICAL	Terminal - 3 amp continuous service. Mates to round, square, rectangular leads .017" to .030".
MOUNTING	CMC 441 series lens - for dry applications. CMS 442 series lens - for dust/wet conditions. CMC 441 / CMS 442 lens - mounts through a 5/16" diameter panel opening on 1/2" centers. Panel thickness up to 1/8". Wire termination - stripped leads, VCC 450 series single or dual row locking header connectors. Contact factory for other termination options.
TEST DATA	Assembly meets NEMA 6P for water, ice and dust. Additional tests, temperature cycle -40° to +85°C, shock to 6g's, vibration to 2000hz, solar & UV. Tests conducted by Consolidated Laboratories.



U.S. & Foreign Patents Issued.

EASY INSTALLATION

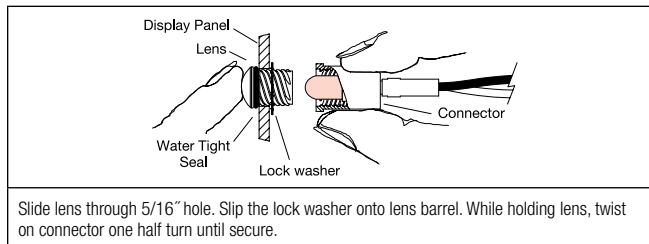

VERSATILITY

CONXRITE® interconnects with internal resistor make LED plug-in connections between panel and power source easy. Options include broad selection of LEDs, choices of wire size, length and color, variety of wire terminations.

BRIGHTNESS

CONXRITE® cable assemblies enhance LED viewing, 180°. Also for use with infrared and photo detection devices. With selected LEDs, brightness can range from 20 to 20,000mcd.

APPLICATION

CONXRITE® assemblies have been tested for UV, solar, shock, vibration and temperature cycling. Sealed version exceeds NEMA 4 for dust, water and ice. Assembly uses include office environments or harsh exterior conditions. Provides ESD circuit protection.

INSTALLATION

CONXRITE® assemblies are easy to install. Slip lens through panel opening, slide lock washer over lens barrel, secure connector to lens by hand with a half turn.

ORDERING CODES

CNX 410	056	E	4	1	12	
CONNECTOR STYLE	RESISTOR	TERMINATION	WIRE SIZE	WIRE COLOR	WIRE LENGTH	
CNX 410 Threaded w/Resistor Use with Lens Assembly: CMC 441 Standard 5mm or CMS 442 Water Tight 5mm	012 120 OHM 018 180 OHM 033 330 OHM 056 560 OHM 120 1200 OHM 220 2200 OHM	X Stripped End E Locking Header Connector	STANDARD 4 24 AWG	1 WHT - BLK 2 RED - BLK	04 4 INCHES 06 6 INCHES 08 8 INCHES 12 12 INCHES 18 18 INCHES 24 24 INCHES	

ADDITIONAL OPTIONS AVAILABLE

RESISTOR SELECTOR

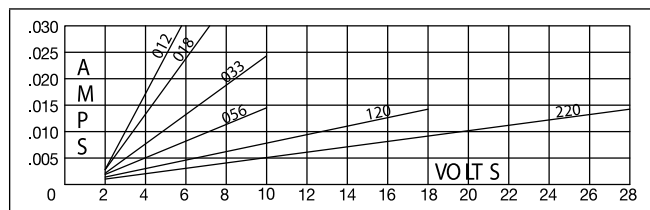

OUTLINE DRAWING

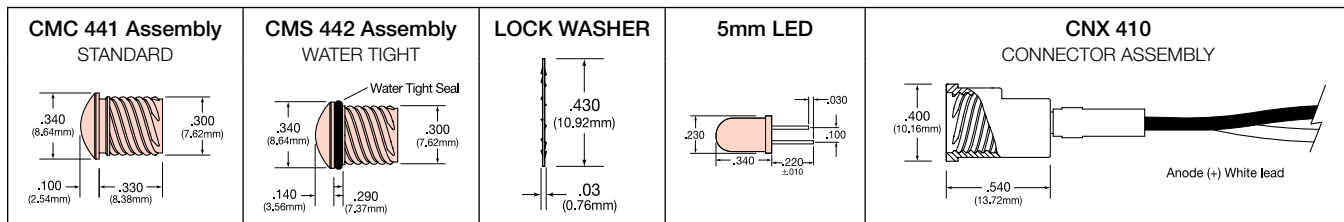

LENS ASSEMBLY SOLD SEPARATELY

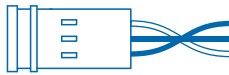

PANEL MOUNT ASSEMBLIES



U.S. & Foreign Patents Issued.

APPLICATION

CONXRITE[®] cable assemblies make quick and easy plug-in connections between panel mounted LEDs with lenses and a power source. Utilizing various cable lengths and cable terminations, CONXRITE[®] interconnects offer a cost reducing solution to interconnection problems.

VERSATILITY

CONXRITE[®] with ballast resistor can be used on circuits from 3 to 28 volts. Panel thickness can vary from 1/32" to 1/4". Makes positive panel connections for either wet or dry applications with CMS lens.

DESIGN

The CONXRITE[®] socket has a molded plastic body with self-contained 1/2 watt resistor. Pre-attached wires are provided with terminals, header connector or with stripped leads.

INSTALLATION

Modular cabling system's plug-in feature simplifies the electrical connection from panel mounted LEDs to PCB, eliminating the need for assembly tools. Cost and time savings from the elimination of soldering and terminal crimping operations are substantial.

SPECIFICATIONS

MATERIAL	Panel connector, Ring and Header connector - Thermoplastic (U.L. Listed Material)
	Terminals - Phosphor bronze, tin plated
	Wire - 24 AWG 7 strand copper, insulated
MOUNTING	Mating Panel Mounts - Plain diffused lens CMC 313, Fresnel lens, CMC 321, Plain end lens CMC 323, Open end mount CMC 285 and Moisture Seal lens CMS 322. See data sheets specs pages 13 & 14.
	Panel Thickness - .030" to .045" use 2ea SPC 060 spacers, .050" - .100" use 1ea. SPC 060 spacer, .105" - .125" SPC 060 not required.
	Hole Size - .281" for all lenses and mounts mentioned above.
	LED Lead Length - CMC 285 trim leads to .350" ± .010". CMC 313, CMC 321, CMC 323 and CMS 322 trim leads to .220" ± .010".

EASY INSTALLATION

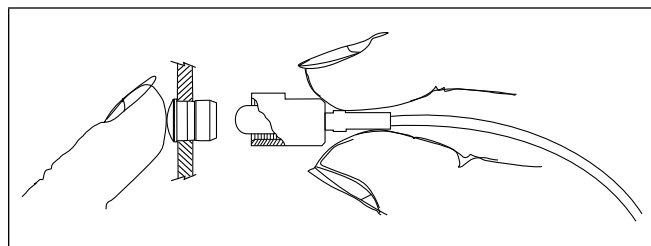

RESISTOR SELECTOR

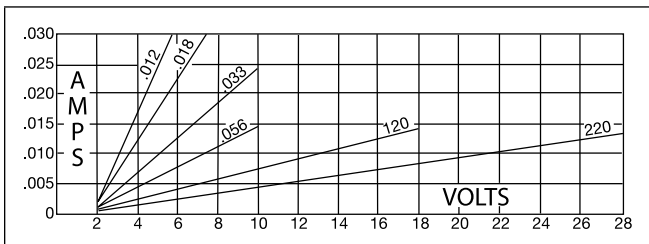

ORDERING CODES

CNX 310 056 E 4 1 08

MODEL	RESISTOR	WIRE TERMINATIONS	WIRE SIZE	WIRE COLOR	WIRE LENGTH
Connector plus resistor only	000 NO RESISTOR	G PLAIN END HEADER CONNECTOR	STANDARD	1 WHT - BLK	04 4 INCHES
Connector plus resistor & wire	012 120	E LOCKING HEADER CONNECTOR	4 24 AWG	2 RED - BLK	06 6 INCHES
	018 180	X WIRE LEAD ENDS STRIPPED			08 8 INCHES
	033 330	Use Model and Resistor code to order connector separately.			12 12 INCHES
	056 560				18 18 INCHES
	120 1200				24 24 INCHES
	220 2200				

OUTLINE DRAWING

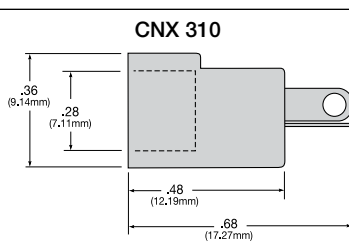
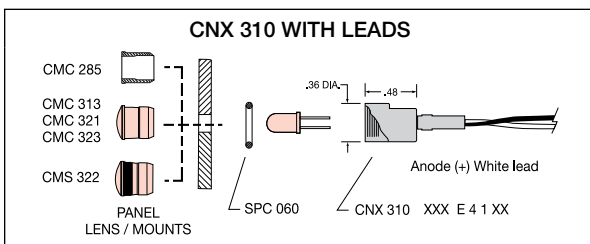

TERMINATIONS

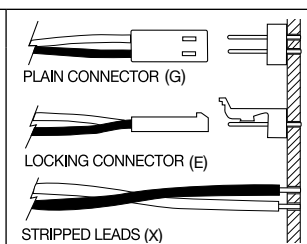

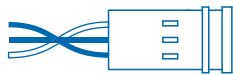

SPECIFICATIONS

MATERIAL	Body	- Thermoplastic (black) U.L. 94 V2
	Pins	- Phosphor bronze .025" square tin plate
	Spacing	- Pins on .100" centers
	Header	- Mates with VCC locking header connector, or equivalent

FEATURES

- Locking lever provides polarity integrity by restricting insertion of locking header in reverse.
- Lever clicks and locks preventing header connector from being retracted inadvertently.
- Locking header available in 2 to 28 pin positions, vertical or horizontal configuration.
- Designed for both vertical and horizontal mounting on the printed circuit board.
- Pins are .025" square brass, tin plated, located on .100" centers.
- Locking header mates with VCC locking header connectors or equivalent.

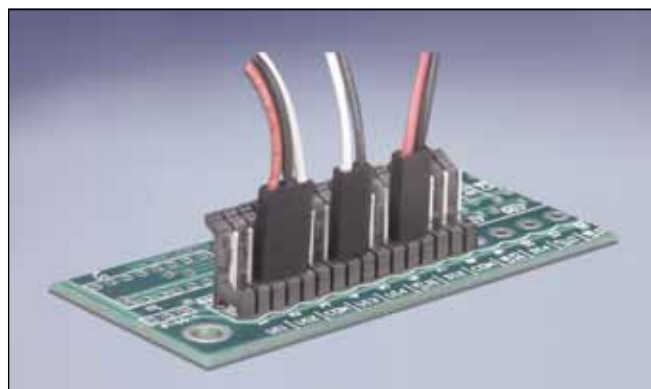

U.S. & Foreign Patents Issued.

ORDERING CODES

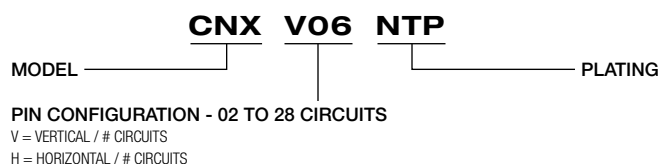

OUTLINE DRAWINGS

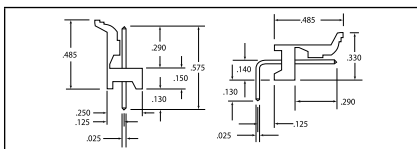

HEADER LOCKING FEATURE

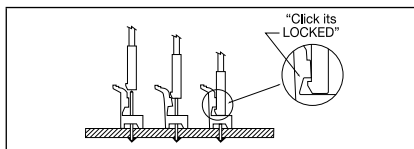

PCB HOLE LAYOUT

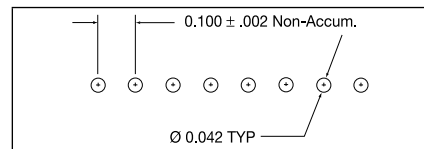

HEADER CONNECTORS

SPECIFICATIONS

MATERIAL	Header connector	- Thermoplastic (black) U.L. 94 V0
	Terminals	- Phosphor bronze, tin plated Rate 3 amp continuous service
	Wire	- 24 AWG, 7 strand copper, PVC insulated
MOUNTING	Non-locking plain header connector mates with any standard .025" square header on .100" centers. Locking header connectors mate with VCC positive locking header 450 series. Also mates with standard and friction header .025" pins on .100" centers.	

FEATURES

- Header connector mates with VCC locking header CNX xxx, Molex 6373, 7478 friction header or equal.
- Header connectors 2, 3, 4, 6 and 8 position are end-to-end stackable.
- Header connectors with or without locking tab, rated U.L. 94 V0.
- Terminal's unique tri-finger design mates with pins from .017" round to .025" square.
- Terminals for use specifically with VCC header connectors.
- Terminals designed for use with wire rating 24 AWG 300V, 105°C.

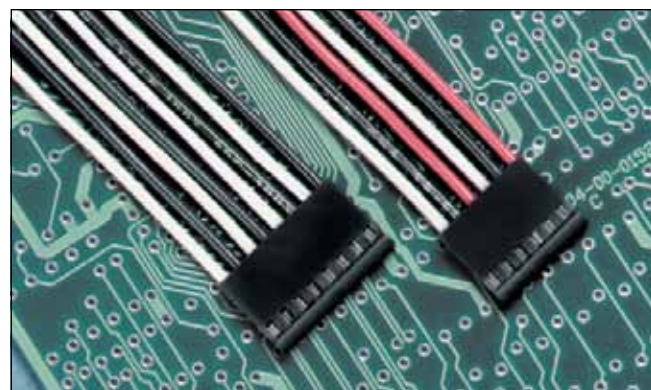

U.S. & Foreign Patents Issued.

**ONLY AVAILABLE WITH WIRES
CALL FOR ORDER INFORMATION**

HEADER CONNECTORS



INTERCONNECTORS

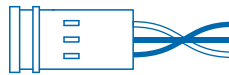

CONNECTORS

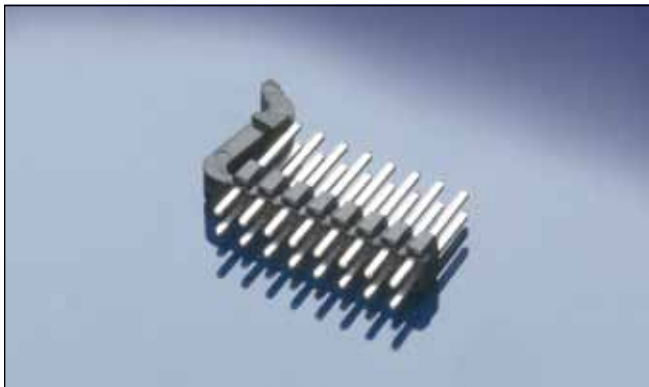

U.S. & Foreign Patents Issued.

SPECIFICATIONS

MATERIAL	Body	- Thermoplastic (black) U. L. 94 V0
	Lever	- Thermoplastic Nylon 6-6 for flexibility U.L. 94 V2
	Pins	- Brass .025" square, tin plate
	Spacing	- Dual row, 4 to 16 circuits on .100" X .100" centers
	Header	- Mates with VCC, 450 4xx series, female locking connector.

P C BOARD LAYOUT

	Dim. A.	Circuits	Dim. A.	Circuits
	.100"	2 X 2	.500"	2 X 6
	.200"	2 X 3	.600"	2 X 7
	.300"	2 X 4	.700"	2 X 8
	.400"	2 X 5		

ORDERING CODES

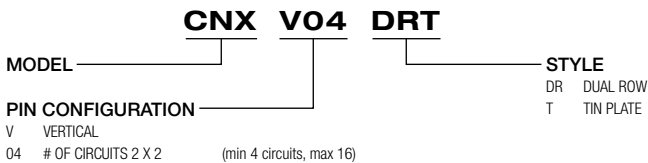

FEATURES

- "Click it's locked" prevents inadvertent retraction of the connector.
- Lever detent prevents reverse insertion of the connector for polarity integrity.
- Vertical locking headers are available in four to sixteen pin circuits.
- Header contact pins are .025" square on .100" x .100" centers.
- Locking header mates with VCC header connector 450 xxx Series.
- Standoff ribs provide a .010" board clearance for easy flux cleansing.

OUTLINE DRAWING

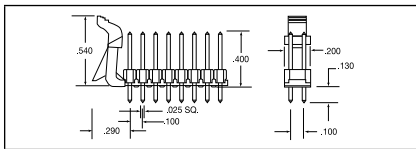

LOCKING FEATURE

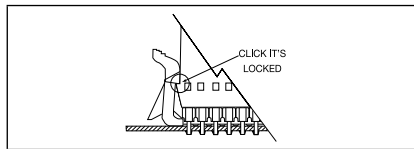

POLARITY FEATURE

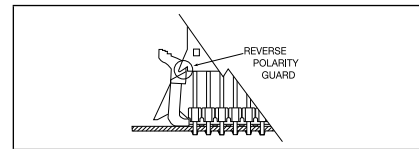

DUAL ROW "SLIM LINE" FEMALE LOCKING CONNECTORS



U.S. & Foreign Patents Issued.

**ONLY AVAILABLE WITH WIRES
CALL FOR ORDER INFORMATION**

SPECIFICATIONS

MATERIAL	Connector	- Thermoplastic (black) U.L. 94 V0 4 to 16 circuits, dual row, with locking and polarizing latches
	Terminals	- Phosphor bronze, tin plated 3 amp continuous service rating
	Wire	- 24 AWG, 7 strand copper, PVC insulated. 300V 105°C
		Call factory for additional options. Mates with VCC CNX DRT VXX positive locking dual row pin header (.025" sq pins on .100" centers)

FEATURES

- Designed with a positive locking mechanism. "Click it's Locked".
- Polarization is preserved by means of connector latches.
- Available from four to sixteen circuit configurations.
- Terminals are tested for 3 amp continuous service.
- Available with 24 AWG stranded wire rated at 300V 105°C rating.
- Thermoplastic materials U.L. rated at 94 V0.

DUAL ROW HEADER CONNECTORS

P/N	DIM. A.	Circuits	P/N	DIM. A.	Circuits
450 404	.245"	2 X 2	450 412	.625"	2 X 6
450 406	.325"	2 X 3	450 414	.725"	2 X 7
450 408	.425"	2 X 4	450 416	.825"	2 X 8
450 410	.525"	2 X 5			



SPECIFICATIONS

MATERIAL	Mount - Polycarbonate; (black - clear) Ring - Polypropylene (black) (U.L. Listed Material)
DESIGN	Permits LED to slide into mount without restriction. Tip of LED is exposed while mount provides contrast on front of display panel.
MOUNTING	Mounts through front of panel. Retaining ring secures mount when used with PCB mounted LED. With interconnect cable, mount is secured by use of an LED connector. 3mm (SMC 130) mounts in a .171" (4.34mm) hole on 1/4" centers. Panel thickness 1/32" to 1/16". 5mm (CMC 285) mounts in a .281" (7.14mm) hole on 3/8" centers. Panel thickness 1/32" to 1/8". See specs. page 18 for use with CNX connectors.
SOCKET	3mm .130" OD trim leads from base of LED to a length of .400" (10.16mm) for all panel thicknesses. 5mm .230" OD trim leads from base of LED to a length of .350" (8.89mm) for all panel thicknesses.



U.S. & Foreign Patents Issued.

VERSATILITY

CLIPMOUNT[®] LED mounts provide a method of displaying PCB or panel mounted LEDs on a display panel. These mounts are available in either black or clear allowing an LED viewing angle of up to 180 degrees. Mounts are available for both 3mm and 5mm LEDs.

BRIGHTNESS

CLIPMOUNT[®] LED mounts provide direct viewing of the LED. Mono and multicolor LEDs as well as infrared and photo-detection devices can be mounted in this manner. This design also permits use of either diffused or nondiffused LEDs.

APPLICATION

CLIPMOUNT[®] mounts permit the panel display of a PCB mounted LED without its physical attachment to the front panel. This mount enables the use of interconnects between display panels and circuit boards.

INSTALLATION

CLIPMOUNT[®] LED mounts are easily installed for PCB mounted LEDs. Simply slide mount through a 9/32" panel hole and press retaining ring into place. The LED is now able to slide in and out of mount without its physical attachment to front panel. For interconnect applications, hold mount tightly to panel with a nut driver and press connector with LED on from rear.

PRINTED CIRCUIT BOARD ASSEMBLY

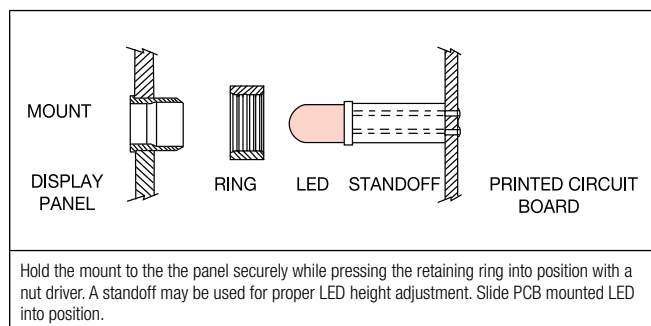

ORDERING CODES

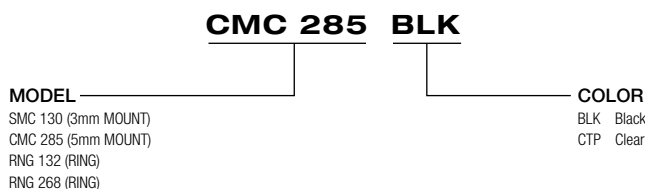

INTERCONNECT CABLE ASSEMBLY

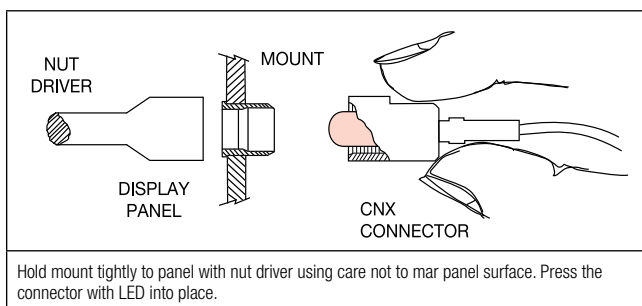

OUTLINE DRAWING

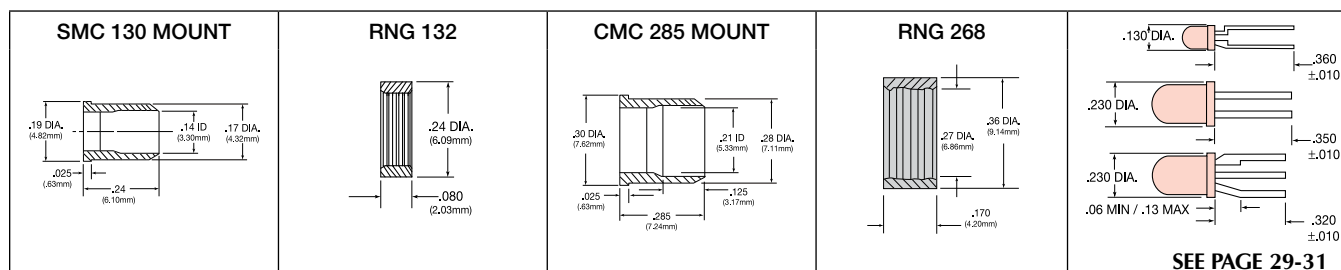

SEE PAGE 29-31

PANEL MOUNTS



MOUNTING CLIPS



U.S. & Foreign Patents Issued.

ORDERING CODES

CLP 125 BLK

MODEL _____ **COLOR** _____
 CLP 125 Standard clip BLK Black only
 CLP 126 Extended clip CLP 129 Inner reflector clip
 CLP 127 Outer reflector clip SPC 125 retaining ring

OUTLINE DRAWINGS

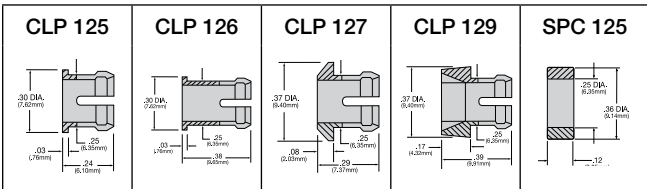

SPECIFICATIONS

MATERIAL	Clip - Polycarbonate, Spacer - Polypropylene (U.L. Listed Materials).
DESIGN	Style - Inner, outer reflector, standard clip, (short and extended).
MOUNTING	Mount through front of panel. Mounting holes should be deburred but not chamfered. Hole size .250" (6.35mm), holes on 3/8" centers. Panel thickness for CLP 125, 127 & 129, 1/32" to 1/8". For CLP 126, 1/8" to 1/4". Complete assembly using SPC 125. CLIPMOUNT® CLP 125, 127 & 129 with CONXRITE®, maximum panel thickness .110". With CLP 126, maximum .250" panel thickness.
LEDs	5mm standard or low profile, diffused or non-diffused.

FEATURES

- Universal, used for mounting all standard 5mm LEDs.
- Low cost installation method for panel mounting LEDs.
- Styles include inner/outer reflector, standard and extended clip types.
- Accommodate panel thickness ranging from .032" to .250".
- LEDs are replaceable when mount is used with CONXRITE® socket.
- Various styles of CLIPMOUNTS® vastly increase the engineer's range of selection.

CLIPMOUNT

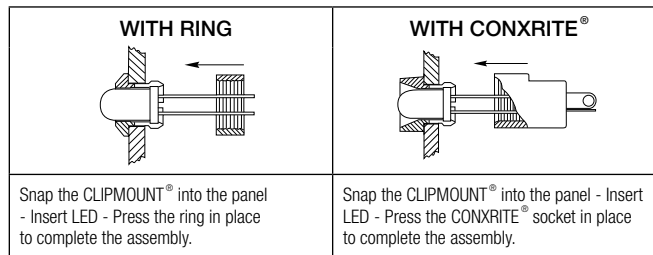

SOLDERLESS LED CONNECTOR

SPECIFICATIONS

MATERIAL	Housing - Polypropylene (natural). Terminals - Phosphor bronze, tin plated, compatible with LED leads. Resistor - Melf 1/2 resistor provides current limiting to 28 volts. Panel Mounts - Recommended lense CMC 321 and CMS 322. CLIPLITE® and CLIPMOUNT® are also acceptable mounts. Note - Trim LED lead length to .275" ± .010" (7.24mm).
-----------------	--

FEATURES

- Internal resistor for 3V to 28V circuits, when external resistor is required or desired, CONXRITE® is available without built-in resistor.
- Requires no tools - provides a simple fast press-fit connection to either CLIPLITE® or CLIPMOUNT®.
- Stress-relieved connection controls the problem of broken LED leads.
- When preassembled to the wiring harness final assembly of the panel mounted LED is greatly simplified.
- Various colored CLIPLITE® lenses are available for use with CONXRITE®.
- Makes field replacement of defective LEDs practical and cost-effective.

OUTLINE DRAWING

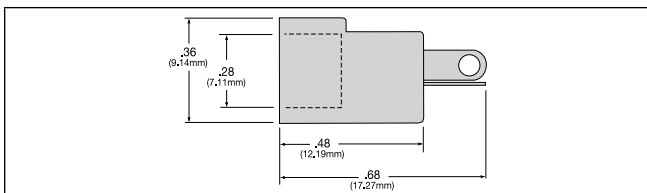

RESISTOR SELECTOR

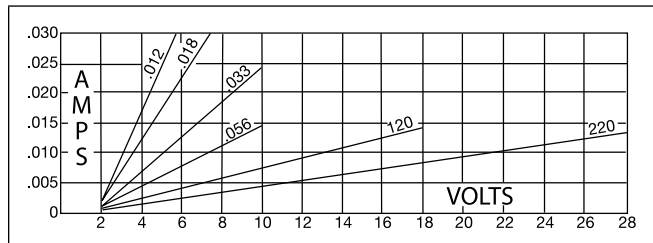

ORDERING CODES

CNX 310 012

MODEL _____	RESISTOR CODE
	CODE VALUE
	000 NO RESISTOR
	012 120 OHMS
	018 180 OHMS
	033 330 OHMS
	056 560 OHMS
	120 1200 OHMS
	220 2200 OHMS

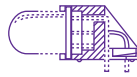

BOARD MOUNTS

LED SOCKETS

SPECIFICATIONS

MATERIAL	Housing - Thermoplastic, (black), U.L. 94 V0 Contacts - Phosphor bronze, tin plated
MOUNTING	PCH Series - Through-hole horizontal mounting sockets, .035" (.89mm) holes on .100" centers. PCV Series - Through-hole vertical mounting sockets, .035" (.89mm) holes on .100" centers. SMD Series - Surface mount, horizontal mounting sockets, .060" (1.52mm) X .060" (1.52mm) component pad.
LED DATA	Standard 3mm and 5mm devices. Leads - Min. .017" (.43mm) round or square.



U.S. & Foreign Patents Issued.

HORIZONTAL MOUNT PCH & SMD SERIES

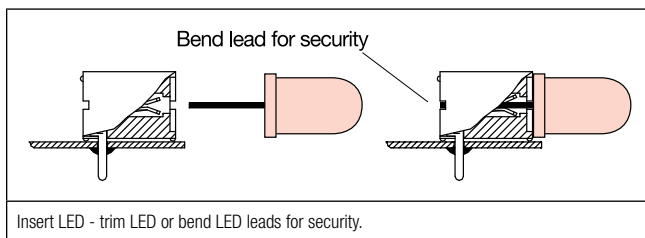

VERSATILITY

P-C-LITE[®] sockets are soldered directly to the PCB which permits easy insertion or removal of the LED. PCH and SMD series mount horizontally, PCV series mounts vertically. STD series standoff can be used to make fine adjustments in the extended length of the LED.

DESIGN

P-C-LITE[®] LED sockets are manufactured from U.L. listed thermoplastics. Unique three finger contact design permits automatic adjustment to the various sizes and shapes of LED leads.

APPLICATION

P-C-LITE[®] mounts are relampable sockets for circuit board mounting of LEDs. They are used to display circuit condition for status, logic and fault detection. The sockets are also used for mounting photodetection type devices as well as incandescent bi-pin lamps.

INSTALLATION

P-C-LITE[®] sockets (PCH/PCV) are affixed to PCB by wave soldering. IR reflow is used for the SMD. Molded standoffs permit easy board cleaning. LED leads can be bent after insertion for added security.

VERTICAL MOUNT PCV SERIES

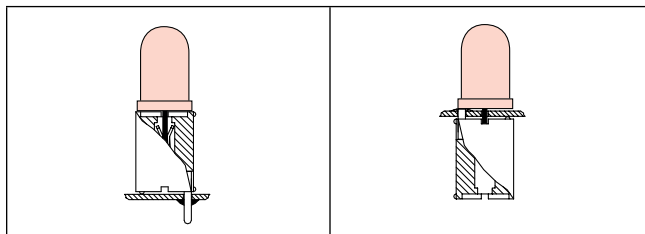

ORDERING CODES

PCH 330 1

MODEL _____

- PCH 330 Horizontal Mount (Single Unit)
- PCH 660 Horizontal Mount (Dual Unit)
- PCH 990 Horizontal Mount (Triple Unit)
- PCV 220 Vertical Mount (Single Unit)
- PCV 440 Vertical Mount (Dual Unit)
- PCV 880 Vertical Mount (Triple Unit)
- SMD 330 Horizontal Surface Mount (Single Unit)
- SMD 660 Horizontal Surface Mount (Dual Unit)
- SMD 990 Horizontal Surface Mount (Triple Unit)

LED COLOR (LED part number)*

- 1 - Red (VAOL-5LAE2)
- 2 - Yellow (VAOL-5LCE2)
- 3 - Green (VAOL-5LDE2)
- 4 - Blue (VAOL-5LSBY2)
- 5 - White (VAOL-5LWY4)
- 10 - Red/Yellow (VAOB-5H2ACE2)
- 11 - Red/Green (VAOB-5H2ADE2)
- 12 - Yellow/Green (VAOB-5H2CDE2)

*Additional LED options available
Available without an LED installed

SOCKET CONFIGURATIONS



OUTLINE DRAWING

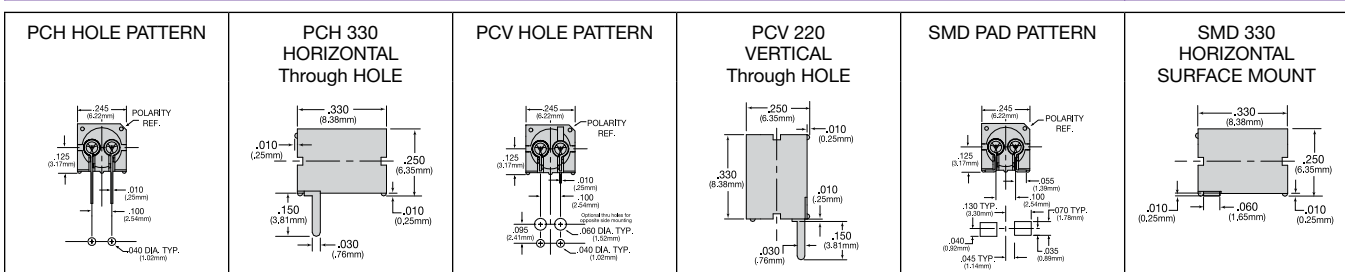

BOARD MOUNTS

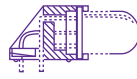

STANDOFFS

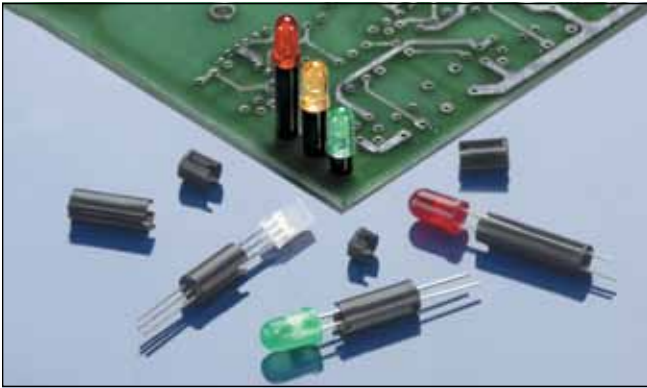

U.S. & Foreign Patents Issued.

OUTLINE DRAWING

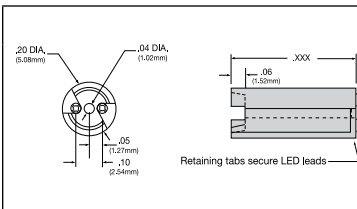

MOUNTING CONF.

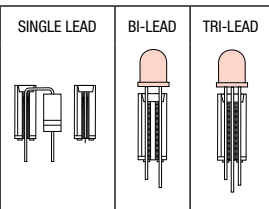

SPECIFICATIONS

MATERIAL	Standoff - Thermoplastic U.L. 94 V0. Color, Black
DESIGN	Channels provide lead separation and lateral stability for components. Molded tabs retain component leads within the standoff for preassembly. Raised pads allow for easy PCB cleaning.
MOUNTING	Suitable for passive components, bi-lead, tri-lead, 3mm, 5mm, LEDs, resistors, capacitors, diodes. Standoffs vary in height from .100" minimum to 1.0" maximum, increments of .010".

ORDERING CODES

STD XXX BLK 1

LENGTH IN INCHES
(.100 to 1.0")

100	230	360	500	630	760	890
110	240	370	510	640	770	900
120	250	380	520	650	780	910
130	260	390	530	660	790	920
140	270	400	540	670	800	930
150	280	410	550	680	810	940
160	290	420	560	690	820	950
170	300	430	570	700	830	960
180	310	450	580	710	840	970
190	320	460	590	720	850	980
200	330	470	600	730	860	990
210	340	480	610	740	870	1.0
220	350	490	620	750	880	

LED COLORS (LED part number)*

- 1 - Red (VAOL-5LAE2)
- 2 - Yellow (VAOL-5LCE2)
- 3 - Green (VAOL-5LDE2)
- 4 - Blue (VAOL-5LSBY2)
- 5 - White (VAOL-5LWY4)
- 10 - Red/Yellow (VAOB-5GACT2-SC)
- 11 - Red/Green (VAOB-5GADT2-SC)
- 12 - Yellow/Green (VAOB-5GCdT2-SC)

*Additional LED options available
Available without an LED installed

MOUNT FOR BI/TRI-LEAD LEDs

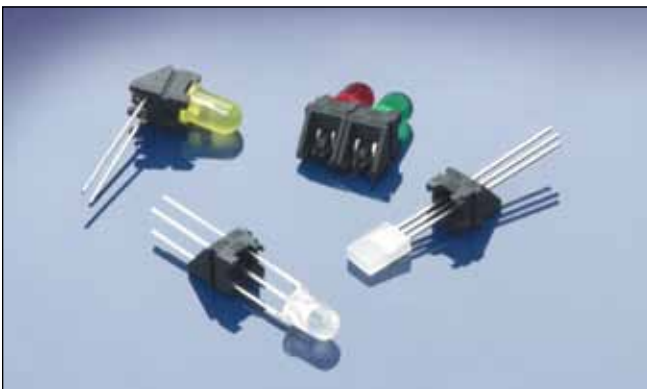

U.S. & Foreign Patents Issued.

ORDERING CODES

PCH 175 1

LED COLOR (LED part number)*

- 1 - Red (VAOL-5LAE2)
- 2 - Yellow (VAOL-5LCE2)
- 3 - Green (VAOL-5LDE2)
- 4 - Blue (VAOL-5LSBY2)
- 5 - White (VAOL-5LWY4)
- 10 - Red/Yellow (VAOB-5GACT2-SC)
- 11 - Red/Green (VAOB-5GADT2-SC)
- 12 - Yellow/Green (VAOB-5GCdT2-SC)

*Additional LED options available
Available without an LED installed

SPECIFICATIONS

MATERIAL	Housing - Thermoplastic (black) U.L. 94 V0.
DESIGN	PCH 175 - Right angle through-hole mount for LEDs. Can be used as a single LED mount or banded together in an array with its dove-tail interlocking feature. When banded together with the PCH 175 the LEDs are on .250" centers.
LEDs	5mm size - round or rectangular shape with or without flange. Bi-lead, standard .100" lead spacing. Tri-lead, either .050" or .100" lead spacing. Both the bi-lead and tri-lead LEDs can also be combined in arrays with one another.

OUTLINE DRAWING

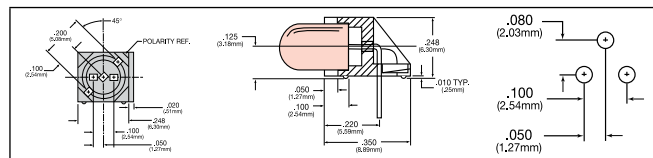

PCB MOUNTING

BI & TRI-LEAD LEDs	LEDs IN ARRAYS
Form leads with the mount, snap leads into retaining tabs.	Bi-lead and tri-lead LEDs can be combined with dove-tail interlocking feature.

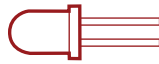

PART NUMBER	DESCRIPTION	LENS TYPE	EMITTED COLOR	WAVELENGTH λ_D (nm)	Luminous Intensity IV (mcd) @ 20mA	Viewing Angle Degree 2 θ 1/2	DIMENSIONS
VAOB-3GACE2-C	Bi-Color	Milky Diffused	Red/Yellow	640/590	100/80	-	
VAOB-3GADE2-C	Bi-Color	Milky Diffused	Red/Green	640/570	100/80	-	
VAOB-3GCDE2-C	Bi-Color	Milky Diffused	Yellow/Green	590/570	80/80	-	

PART NUMBER	DESCRIPTION	LENS TYPE	EMITTED COLOR	WAVELENGTH D (nm)	Luminous Intensity IV (mcd) @ 20mA	Viewing Angle Degree 2 θ 1/2	DIMENSIONS
VAOL-3GAE4	Single Color	Clear	Red	643	150	30	
VAOL-3GCE4	Single Color	Clear	Yellow	590	150	30	
VAOL-3GDE4	Single Color	Clear	Green	570	170	30	
VAOL-3GGE4	Single Color	Clear	Green	570	1300	30	
VAOL-3GRE4	Single Color	Clear	Red	625	2000	30	
VAOL-3GY4	Single Color	Clear	Yellow	590	2000	30	
VAOL-3GSBY4	Single Color	Clear	Blue	470	2500	30	
VAOL-3GWR4	Single Color	Clear	White	-	3500	30	
VAOL-3LAE2	Single Color	Diffused	Red	640	80	60	
VAOL-3LCE2	Single Color	Diffused	Yellow	590	85	60	
VAOL-3LDE2	Single Color	Diffused	Green	570	80	60	
VAOL-3LSBY1	Single Color	Milky Diffused	Blue	470	700	60	
VAOL-3LSBY2	Single Color	Diffused	Blue	470	1200	60	
VAOL-3LSBY4	Single Color	Clear	Blue	470	1200	60	
VAOL-3LWY4	Single Color	Clear	White	-	2500	60	
VAOL-3EUV0Y4	Single Color	Clear	Purple	405	150	15	
VAOL-3EUV8Y4	Single Color	Clear	Purple	385	72	15	
VAOL-3GUV0Y4	Single Color	Clear	Purple	405	120	30	
VAOL-3GUV8Y4	Single Color	Clear	Purple	385	55	30	

PART NUMBER	DESCRIPTION	LENS TYPE	EMITTED COLOR	WAVELENGTH D (nm)	Luminous Intensity IV (mcd) @ 20mA	Viewing Angle Degree 2 θ 1/2	DIMENSIONS
VAOL-3HAE4	Single Color-Flangeless	Clear	Red	643	150	30	
VAOL-3HCE4	Single Color-Flangeless	Clear	Yellow	590	150	30	
VAOL-3HDE4	Single Color-Flangeless	Clear	Green	570	170	30	
VAOL-3HSBY4	Single Color-Flangeless	Clear	Blue	470	2500	30	
VAOL-3HWY4	Single Color-Flangeless	Clear	White	-	3500	30	
VAOL-3MEA2	Single Color-Flangeless	Diffused	Red	640	80	60	
VAOL-3MCE2	Single Color-Flangeless	Diffused	Yellow	590	80	60	
VAOL-3MDE2	Single Color-Flangeless	Diffused	Green	570	80	60	
VAOL-3LMSBY2	Single Color-Flangeless	Diffused	Blue	470	1200	60	
VAOL-3MWY4	Single Color-Flangeless	Clear	White	-	2500	60	

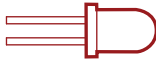

5mm (T-1 3/4)

PART NUMBER	DESCRIPTION	LENS TYPE	EMITTED COLOR	WAVELENGTH λ.D (nm)	Luminous Intensity IV (mcd) @ 20mA	Viewing Angle Degree 2 θ ½	DIMENSIONS
VAOB-5GACE2-C	Bi-Color	White Diffused	Red/Yellow	640/590	100/80	-	
VAOB-5GADE2-C	Bi-Color	White Diffused	Red/Green	640/570	100/80	-	
VAOB-5GCDE2-C	Bi-Color	White Diffused	Yellow/Green	590/570	80/80	-	

PART NUMBER	DESCRIPTION	LENS TYPE	EMITTED COLOR	WAVELENGTH λ.D (nm)	Luminous Intensity IV (mcd) @ 20mA	Viewing Angle Degree 2 θ ½	DIMENSIONS
VAOB-5GADT2-SC	Bi-Color	Milky Diffused	Red/Green	640/570	90/70	-	
VAOB-5GCDT2-SC	Bi-Color	Milky Diffused	Yellow/Green	590/570	70/63	-	
VAOB-5GACT2-SC	Bi-Color	Milky Diffused	Red/Yellow	640/590	80/70	-	

PART NUMBER	DESCRIPTION	LENS TYPE	EMITTED COLOR	WAVELENGTH D (nm)	Luminous Intensity IV (mcd) @ 20mA	Viewing Angle Degree 2 θ ½	DIMENSIONS
VAOL-5701AE4	Single Color	Clear	Red	643	85	100	
VAOL-5701CE4	Single Color	Clear	Yellow	590	80	100	
VAOL-5701DE4	Single Color	Clear	Green	570	100	100	
VAOL-570SBY4	Single Color	Clear	Blue	465	1000	100	
VAOL-570WY4	Single Color	Clear	White	-	1800	100	

PART NUMBER	DESCRIPTION	LENS TYPE	EMITTED COLOR	WAVELENGTH D (nm)	Luminous Intensity IV (mcd) @ 20mA	Viewing Angle Degree 2 θ ½	DIMENSIONS
VAOL-5MAE2	Single Color-Flangeless	Diffused	Red	640	80	60	
VAOL-5MCE2	Single Color-Flangeless	Diffused	Yellow	590	80	60	
VAOL-5MDE2	Single Color-Flangeless	Diffused	Green	570	50	60	
VAOL-5MSBY2	Single Color-Flangeless	Diffused	Blue	470	1500	60	
VAOL-5MWY2	Single Color-Flangeless	Milky Diffused	White	-	5000	60	

PART NUMBER	DESCRIPTION	LENS TYPE	EMITTED COLOR	WAVELENGTH D (nm)	Luminous Intensity IV (mcd) @ 20mA	Viewing Angle Degree 2 θ ½	DIMENSIONS
VAOB-5H2ACE2	Bi-color Bi-lead Flangeless	Diffused	Red/Yellow	640/590	100/80	-	
VAOB-5H2ADE2	Bi-color Bi-lead flangeless	Diffused	Red/Green	640/570	100/80	-	
VAOB-5H2CDE2	Bi-color Bi-lead Flangeless	Diffused	Yellow/Green	590/570	80/80	-	

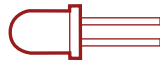

5mm (T-1 3/4) - 10mm (T-3 1/8)

PART NUMBER	DESCRIPTION	LENS TYPE	EMITTED COLOR	WAVELENGTH D (nm)	Luminous Intensity IV (mcd) @ 20mA	Viewing Angle Degree 2 θ 1/2	DIMENSIONS
VAOL-5GAE4	Single Color	Clear	Red	643	250	30	
VAOL-5GCE4	Single Color	Clear	Yellow	590	380	30	
VAOL-5GDE4	Single Color	Clear	Green	570	380	30	
VAOL-5GSBY4	Single Color	Clear	Blue	460	7000	30	
VAOL-5GWY4	Single Color	Clear	White	-	7000	30	
VAOL-5LAE1	Single Color	Milky Diffused	Red	640	80	60	
VAOL-5LAE2	Single Color	Diffused	Red	640	100	60	
VAOL-5LCE1	Single Color	Milky Diffused	Yellow	590	80	60	
VAOL-5LCE2	Single Color	Diffused	Yellow	590	100	60	
VAOL-5LDE1	Single Color	Milky Diffused	Green	570	50	60	
VAOL-5LDE2	Single Color	Diffused	Green	570	150	60	
VAOL-5LSBY1	Single Color	Milky Diffused	Blue	470	1500	60	
VAOL-5LSBY2	Single Color	Diffused	Blue	462	1500	60	
VAOL-5LSBY4	Single Color	Clear	Blue	462	1500	60	
VAOL-5LWY4	Single Color	Clear	White	-	4000	60	
VAOL-5EUV0T4	Single Color	Clear	Purple (UV)	405	200	15	
VAOL-5EUV8T4	Single Color	Clear	Purple (UV)	385	100	15	
VAOL-5GUV0T4	Single Color	Clear	Purple (UV)	405	160	30	
VAOL-5GUV8T4	Single Color	Clear	Purple (UV)	385	80	30	

10mm (T-3 1/8)

PART NUMBER	DESCRIPTION	LENS TYPE	EMITTED COLOR	WAVELENGTH λD (nm)	Luminous Intensity IV (mcd) @ 20mA	Viewing Angle Degree 2 θ 1/2	DIMENSIONS
VAOB-10GACE2-C	Bi-Color	White Diffused	Red/Yellow	640/590	100/90	-	
VAOB-10GADE2-C	Bi-Color	White Diffused	Red/Green	640/570	100/80	-	
VAOB-10GCDE2-C	Bi-Color	White Diffused	Yellow/Green	590/570	90/80	-	

PART NUMBER	DESCRIPTION	LENS TYPE	EMITTED COLOR	WAVELENGTH D (nm)	Luminous Intensity IV (mcd) @ 20mA	Viewing Angle Degree 2 θ 1/2	DIMENSIONS
VAOL-10GAT4	Single Color	Clear	Red	640	655	30	
VAOL-10GCE4	Single Color	Clear	Yellow	590	593	30	
VAOL-10GDE4	Single Color	Clear	Green	570	350	30	
VAOL-10GGE4	Single Color	Clear	Green	572	1300	25	
VAOL-10GRE4	Single Color	Clear	Red	623	2500	25	
VAOL-10GYE4	Single Color	Clear	Yellow	590	2500	25	
VAOL-10GSBY4	Single Color	Clear	Blue	470	7000	30	
VAOL-10GWY4	Single Color	Clear	White	-	8000	30	

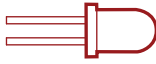

PART NUMBER	DESCRIPTION	LENS TYPE	EMITTED COLOR	WAVELENGTH	Viewing Angle	DIMENSIONS
VAOL-S4RP4	0402	Clear	Red	624	120	
VAOL-S4YP4	0402	Clear	Yellow	589	120	
VAOL-S4GT4	0402	Clear	Yellowish Green	573	120	
VAOL-S4SB4	0402	Clear	Blue	468	120	
VAOL-S4WR4	0402	Yellow Diffused Lens	White		130	

PART NUMBER	DESCRIPTION	LENS TYPE	EMITTED COLOR	WAVELENGTH	Viewing Angle	DIMENSIONS
VAOL-S6RP4	0603	Clear	Red	650	120	
VAOL-S6YP4	0603	Clear	Yellow	589	120	
VAOL-S6GT4	0603	Clear	Yellowish Green	573	120	
VAOL-S6SB4	0603	Clear	Blue	468	120	
VAOL-S6WR4	0603	Yellow Diffused Lens	White		130	

PART NUMBER	DESCRIPTION	LENS TYPE	EMITTED COLOR	WAVELENGTH	Viewing Angle	DIMENSIONS
VAOL-S8RP4	0805	Clear	Red	624	140	
VAOL-S8YP4	0805	Clear	Yellow	589	140	
VAOL-S8GT4	0805	Clear	Yellowish Green	573	140	
VAOL-S8SB4	0805	Clear	Blue	468	140	
VAOL-S8WR4	0805	Yellow Diffused Lens	White		150	

PART NUMBER	DESCRIPTION	LENS TYPE	EMITTED COLOR	WAVELENGTH	Viewing Angle	DIMENSIONS
VAOL-S12RP4	1206	Clear	Red	624	130	
VAOL-S12YP4	1206	Clear	Yellow	589	130	
VAOL-S12GT4	1206	Clear	Yellowish Green	573	130	
VAOL-S12SB4	1206	Clear	Blue	468	130	
VAOL-S12WR4	1206	Yellow Diffused Lens	White		140	

PART NUMBER	DESCRIPTION	LENS TYPE	EMITTED COLOR	WAVELENGTH	Viewing Angle	DIMENSIONS
VAOL-S2RP4	PLCC2	Clear	Red	624	120	
VAOL-S2YP4	PLCC2	Clear	Yellow	589	120	
VAOL-S2GT4	PLCC2	Clear	Yellowish Green	573	120	
VAOL-S2SB4	PLCC2	Clear	Blue	468	120	
VAOL-S2WR4	PLCC2	Clear	White		120	

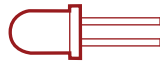

PART NUMBER	LED SIZE	DESCRIPTION	LENS TYPE	EMITTED COLOR	VIEWING ANGLE	WAVELENGTH	INTENSITY	DIMENSIONS
VAOL-S1513RGB	3.2 X2.6	PCB Type	Water Clear	RGB	120	632/518/468	140/180/70	Visit www.vcclite.com for dimensional data.
VAOL-5050RGB-W1		PLCC6	Water Clear	RGB	120	633/535/472	715/1420/450	
VAOL-SP4RGB4		PLCC4	Water Clear	RGB	120	631/30/475	285/450/180	
VAOL-S19337RGB	1.6 X1.6	PCB Type	Water Clear	RGB	120	624/525/470	100/180/50	
VAOL-S2223RGB	2.7 X 1.0	PCB Type	Water Clear	RGB	120	630/540/480	72/180/45	

PART NUMBER	DESCRIPTION	LENS TYPE	EMITTED COLOR	VIEWING ANGLE	WAVELENGTH	INTENSITY	DIMENSIONS
VAOL-SW1xAx-SA	1W LED on Starboard	Clear	White	130		90 lm	
VAOL-SX1x-SA	1W LED on Starboard	Clear	Warm White	130		80 lm	
VAOL-SR1-xAx-SA	1W LED on Starboard	Clear	Red	120	630	50 lm	
VAOL-SO1xAx-SA	1W LED on Starboard	Clear	Red/Orange	120	620	55 lm	
VAOL-SA1xAx-SA	1W LED on Starboard	Clear	Amber	120	595	50 lm	
VAOL-ST1xAx-SA	1W LED on Starboard	Clear	Green	150	535	90 lm	
VAOL-SB1xAx-SA	1W LED on Starboard	Clear	Blue	150	475	35 lm	

PART NUMBER	DESCRIPTION	LENS TYPE	EMITTED COLOR	VIEWING ANGLE	WAVELENGTH	INTENSITY	DIMENSIONS
VAOP-EWS-1	1W LED (Emitter Only)	Clear	White	125		80 lm	Visit www.vcclite.com for dimensional data.
VAOP-EWS-3	1W LED (Emitter Only)	Clear	White	125		136 lm	
VAQS-SP4W4	0.5W LED PLCC4 (Emitter Only)	Clear	White	125		25 lm	

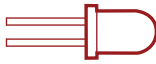

SEVEN SEGMENT AND DOT-MATRIX

PART NUMBER	DESCRIPTION	EMITTED COLOR	WAVLENGTH	CORRESPONDING SPEC SHEET
VAOS-C301G9-BW/40	0.3" - Common Cathode	Green	565	VAOS-C_A301G9-BW/40
VAOS-A301G9-BW/40	0.3" - Common Anode	Green	565	VAOS-C_A301G9-BW/40
VAOS-C301S9-BW/40	0.3" - Common Cathode	Super Bright Red	660	VAOS-C_A301S9-BW/40
VAOS-A301S9-BW/40	0.3" - Common Anode	Super Bright Red	660	VAOS-C_A301S9-BW/40
VAOS-C402G9-BW/50	0.4" - Common Cathode	Green	565	VAOS-C_A402G9-BW/50
VAOS-A402G9-BW/50	0.4" - Common Anode	Green	565	VAOS-C_A402G9-BW/50
VAOS-C402S9-BW/50	0.4" - Common Cathode	Super Bright Red	660	VAOS-C_A402S9-BW/50
VAOS-A402S9-BW/50	0.4" - Common Anode	Super Bright Red	660	VAOS-C_A402S9-BW/50
VAOS-C561G9-BW/43	0.56" - Common Cathode	Green	565	VAOS-C_A561G9-BW/43
VAOS-A561G9-BW/43	0.56" - Common Anode	Green	565	VAOS-C_A561G9-BW/43
VAOS-C561S9-BW/43	0.56" - Common Cathode	Super Bright Red	660	VAOS-C_A561S9-BW/43
VAOS-A561S9-BW/43	0.56" - Common Anode	Super Bright Red	660	VAOS-C_A561S9-BW/43

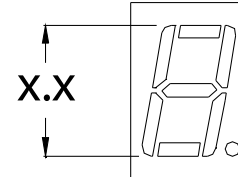

PART NUMBER	DESCRIPTION	EMITTED COLOR	WAVLENGTH	CORRESPONDING SPEC SHEET
VAOD-C301G9-BW/47	0.3" - Common Cathode	Green	565	VAOD-C_A301G9-BW/47
VAOD-A301G9-BW/47	0.3" - Common Anode	Green	565	VAOD-C_A301G9-BW/47
VAOD-C301S9-BW/47	0.3" - Common Cathode	Super Bright Red	660	VAOD-C_A301S9-BW/47
VAOD-A301S9-BW/47	0.3" - Common Anode	Super Bright Red	660	VAOD-C_A301S9-BW/47
VAOD-C403G9-BW/45	0.4" - Common Cathode	Green	565	VAOD-C_A403G9-BW/45
VAOD-A403G9-BW/45	0.4" - Common Anode	Green	565	VAOD-C_A403G9-BW/45
VAOD-C403S9-BW/45	0.4" - Common Cathode	Super Bright Red	660	VAOD-C_A403S9-BW/45
VAOD-A403S9-BW/45	0.4" - Common Anode	Super Bright Red	660	VAOD-C_A403S9-BW/45
VAOD-C565G9-BW/43	0.56" - Common Cathode	Green	565	VAOD-C_A565G9-BW/43
VAOD-A565G9-BW/43	0.56" - Common Anode	Green	565	VAOD-C_A565G9-BW/43
VAOD-C565S9-BW/43	0.56" - Common Cathode	Super Bright Red	660	VAOD-C_A565S9-BW/43
VAOD-A565S9-BW/43	0.56" - Common Anode	Super Bright Red	660	VAOD-C_A565S9-BW/43

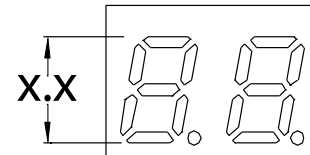

PART NUMBER	DESCRIPTION	EMITTED COLOR	WAVLENGTH	CORRESPONDING SPEC SHEET
VAOM-C07573G9-BW/32	.7" - Common Cathode	Green	565	VAOM-C_A07573G9-BW/32
VAOM-A07573G9-BW/32	.7" - Common Anode	Green	565	VAOM-C_A07573G9-BW/32
VAOM-C07573S9-BW/32	.7" - Common Cathode	Super Bright Red	660	VAOM-C_A07573S9-BW/32
VAOM-A07573S9-BW/32	.7" - Common Anode	Super Bright Red	660	VAOM-C_A07573S9-BW/32
VAOM-C12571G-BW/40	1.2" - Common Cathode	Green	565	VAOM-C_A12571G-BW/40
VAOM-A12571G-BW/40	1.2" - Common Anode	Green	565	VAOM-C_A12571G-BW/40
VAOM-C12571S-BW/40	1.2" - Common Cathode	Super Bright Red	660	VAOM-C_A12571S-BW/40
VAOM-A12571S-BW/40	1.2" - Common Anode	Super Bright Red	660	VAOM-C_A12571S-BW/40
VAOM-C20571G-BW/40	2.0" - Common Cathode	Green	565	VAOM-C_A20571G-BW/40
VAOM-A20571G-BW/40	2.0" - Common Anode	Green	565	VAOM-C_A20571G-BW/40
VAOM-C20571S-BW/40	2.0" - Common Cathode	Super Bright Red	660	VAOM-C_A20571S-BW/40
VAOM-A20571S-BW/40	2.0" - Common Anode	Super Bright Red	660	VAOM-C_A20571S-BW/40

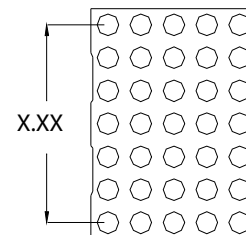

VCC

OPTOELECTRONICS

lighting:theway

VISUAL COMMUNICATIONS COMPANY, INC.

190 Bosstick Boulevard • Suite 101
San Marcos, California 92069 • U.S.A.

Toll Free: (800) 522-5546

Tel: (760) 560-1300

Fax: (760) 560-1301

Email: vccsales@vcclite.com



X-ON Electronics

Largest Supplier of Electrical and Electronic Components

Click to view similar products for [Visual Communications](#) manufacturer:

Other Similar products are found below :

[CNX722C40005W](#) [VAOM-C07573S9-BW/32](#) [2817](#) [139A-403A](#) [2191U5-24V](#) [25P-607W](#) [2620QK1](#) [LPC_127_CTP](#) [STD600BLK](#)
[CMC01R](#) [CNXBE4218](#) [4344](#) [5314N1](#) [1092D3-28V](#) [VC1510145W3](#) [5110F1-5V](#) [B2A-10PK](#) [1052QN5](#) [CNX722C900120T](#) [PML50RFVW](#)
[CNX"C"E"4"1"04](#) [1835LS3-W-CW](#) [2SB-NWG48H](#) [2SB-NWW48H](#) [2623T5](#) [CNX_310_220_E_4_1_08](#) [CNX310033X4124](#) [3150-10PK](#)
[4304H5](#) [VC18602452](#) [L65DR12L](#) [CNX_410_220_X02_4_1_24](#) [LFC063CTP](#) [PML50GFVW](#) [MF200-BCG28H](#) [STD_850_BLK](#) [2152QA5](#)
[2153A5](#) [5302H5-5V](#) [CNX722C50024W](#) [CNX"482"1"RTP"12](#) [L79D-Y125-W](#) [5352T1-5VLC](#) [CNX722C900FVB](#) [6013M5](#)
[CTHS15CIC06ALARM](#) [5602F5-5V](#) [1050A4](#) [5381H3](#) [CTHS15CIC07](#)