

CS3361

Alternator Voltage Regulator FET Driver

The CS3361 integral alternator regulator integrated circuit provides the voltage regulation for automotive, 3-phase alternators.

It drives an external logic level N channel enhancement power FET for control of the alternator field current. In the event of a charge fault, a lamp output pin is provided to drive an external darlington transistor capable of switching on a fault indicator lamp. An overvoltage or no Stator signal condition activates the lamp output.

This IC has customized current sense circuitry enabling it to drive FET transistors. The CS3361 is available in an SOIC-14 package.

Features

- Drives Logic Level Power NFET
- 80 V Load Dump
- Temperature Compensated Regulation Voltage
- Shorted Field Protection Duty Cycle, Self Clearing
- This is a Pb-Free Device



ON Semiconductor®

www.onsemi.com

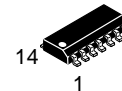

SOIC-14
D SUFFIX
CASE 751A

PIN CONNECTIONS AND MARKING DIAGRAM

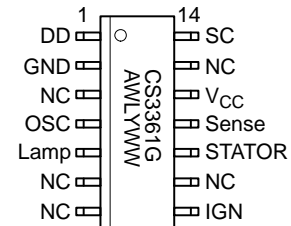

A = Assembly Location
WL = Wafer Lot
YY = Year
WW = Work Week
G = Pb-Free Package

ORDERING INFORMATION

Device	Package	Shipping†
CS3361YDR14G	SOIC-14 (Pb-Free)	2500 / Tape & Reel

†For information on tape and reel specifications, including part orientation and tape sizes, please refer to our Tape and Reel Packaging Specification Brochure, BRD8011/D.

CS3361

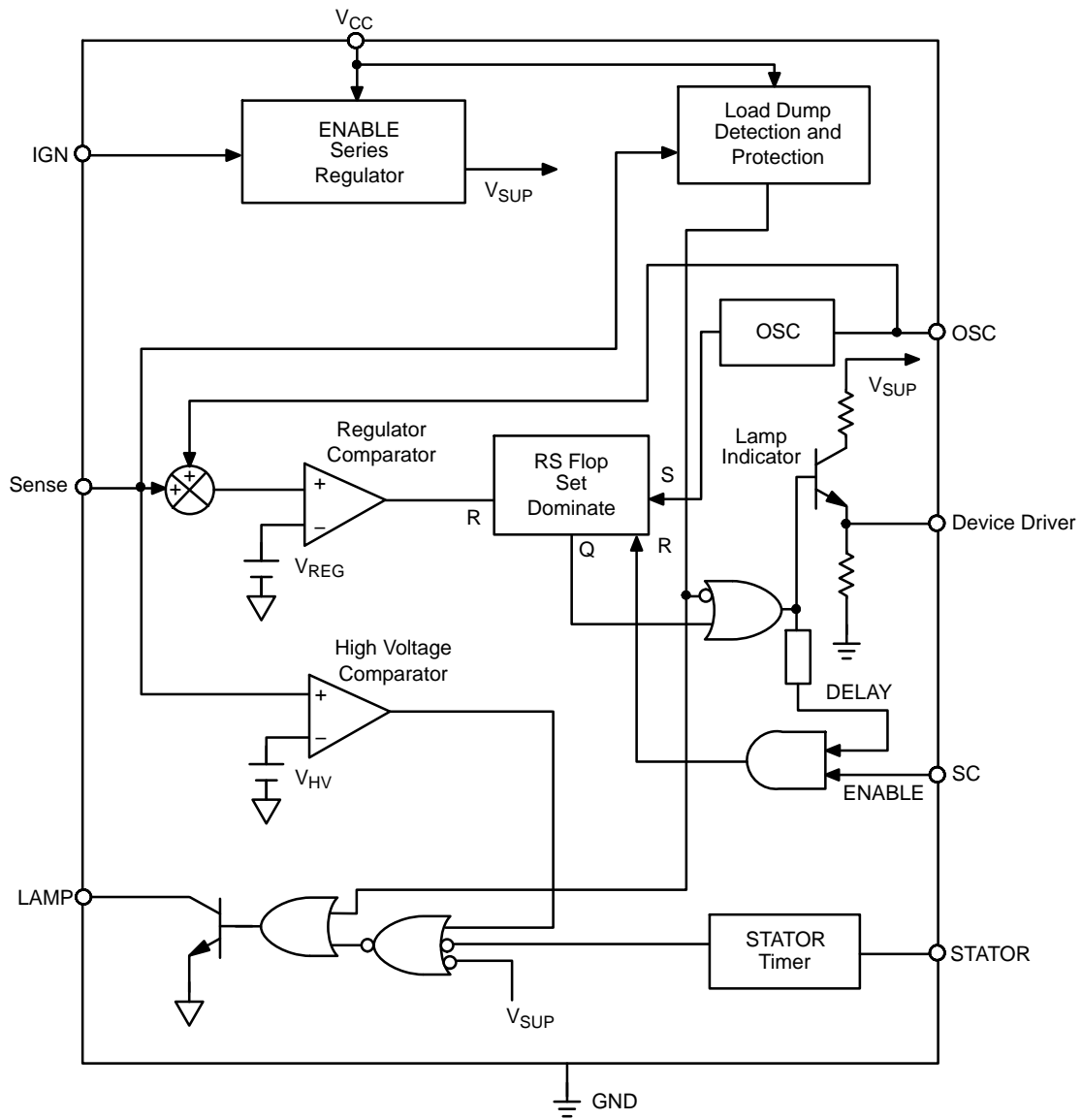

Figure 1. Block Diagram

PACKAGE PIN DESCRIPTION

PIN NO.	PIN SYMBOL	FUNCTION
1	Driver	Output driver for external power switch.
2	GND	Ground.
3, 6, 7, 9, 13	NC	No Connection.
4	OSC	Timing capacitor for oscillator.
5	Lamp	Base driver for lamp driver indicates no stator signal or overvoltage condition.
8	IGN	Switched ignition power up.
10	Stator	Stator signal input for stator timer.
11	Sense	Battery sense voltage regulator comparator input and protection.
12	V _{CC}	Supply for IC.
14	SC	Short circuit sensing.

MAXIMUM RATINGS

Rating	Value	Unit
Storage Temperature Range, T _S	-55 to +165	°C
Junction Temperature Range	-40 to 150	°C
Continuous Supply	27	V
I _{CC} Load Dump (@ V _{CC} = 80 V _{peak})	400	mA
Lead Temperature Soldering: Reflow: (SMD styles only) (Note 1)	260 peak	°C

Stresses exceeding those listed in the Maximum Ratings table may damage the device. If any of these limits are exceeded, device functionality should not be assumed, damage may occur and reliability may be affected.

1. 60 second maximum above 183°C.

PACKAGE THERMAL DATA

Parameter		SO-14	Unit
R _{θJC}	Typical	30	°C/W
R _{θJA}	Typical	125	°C/W

CS3361

ELECTRICAL CHARACTERISTICS (–40°C < T_A < 125°C, –40°C < T_J < 150°C, 9.0 V ≤ V_{CC} ≤ 17 V; unless otherwise specified.)

Characteristic	Test Conditions	Min	Typ	Max	Unit
----------------	-----------------	-----	-----	-----	------

Supply

Supply Current Enabled	–	–	–	10	mA
Supply Current Disabled	–	–	–	50	μA

Driver Stage

Output High Voltage	–	5.5	–	12	V
Output Low Voltage	I _{OL} = 25 μA	–	–	0.35	V
Output High Current	V _{DD} = 1.2 V	–10	–6.0	–4.0	mA
Minimum ON Time	C _{OSC} = 0.022 μF	200	–	–	μs
Minimum Duty Cycle	–	–	6.0	10	%
Short Circuit Duty Cycle	–	1.0	–	5.0	%
Field Switch Turn On Rise Time	–	15	–	75	μs
Field Switch Turn On Fall Time	–	15	–	75	μs

Stator

Input High Voltage	–	10	–	–	V
Input Low Voltage	–	–	–	6.0	V
Stator Time Out	High to Low	6.0	100	600	ms

Lamp

Output High Current	V _{LAMP} @ 3.0 V	–	–	50	μA
Output Low Voltage	I _{LAMP} @ 30 mA	–	–	0.35	V

Ignition

Input High Voltage	I _{CC} > 1.0 mA	1.8	–	–	V
Input Low Voltage	I _{CC} < 100 μA	–	–	0.5	V

Oscillator

Oscillator Frequency	C _{OSC} = 0.022 μF	90	–	210	Hz
Rise Time/Fall Time	C _{OSC} = 0.022 μF	–	17	–	–
Oscillator High Threshold	C _{OSC} = 0.022 μF	–	–	4.5	V

Battery Sense

Input Current	–	–10	–	+10	μA
Regulation Voltage	@25°C, R ₁ = 100 kΩ, R ₂ = 50 kΩ	13.8	–	15.8	V
Proportional Control	–	0.10	–	0.25	V
High Voltage Threshold Ratio	$\frac{V_{\text{High Voltage@LampOn}}}{V_{\text{Regulation@50\%Duty Cycle}}}$	1.083	–	1.190	V/V
High Voltage Hysteresis	–	0.020	–	0.600	V

Product parametric performance is indicated in the Electrical Characteristics for the listed test conditions, unless otherwise noted. Product performance may not be indicated by the Electrical Characteristics if operated under different conditions.

CS3361

TYPICAL PERFORMANCE CHARACTERISTICS

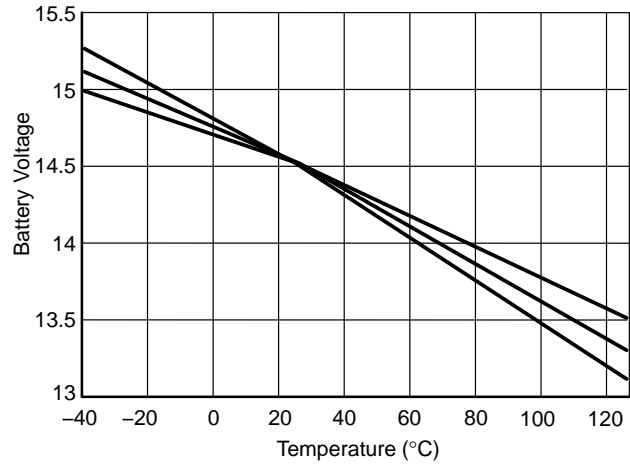

Figure 2. CS3361 Battery Voltage vs. Temperature (°C) Over Process Variation

APPLICATIONS INFORMATION

The CS3361 is designed for use in an alternator charging system.

In a standard alternator design (Figure 3), the rotor carries the field winding. An alternator rotor usually has several N and S poles. The magnetic field for the rotor is produced by forcing current through a field or rotor winding. The stator windings are formed into a number of coils spaced around a cylindrical core. The number of coils equals the number of pairs of N and S poles on the rotor. The alternating current in the stator windings is rectified by the diodes and applied to the regulator. By controlling the amount of field current, the magnetic field strength is controlled and hence the output voltage of the alternator.

Referring to Figure 7, a typical application diagram, the oscillator frequency is set by an external capacitor connected between OSC and ground. The sawtooth waveform ramps between 1.0 V and 3.0 V and provides the timing for the system. For the circuit shown the oscillator frequency is approximately 140 Hz. The alternator voltage is sensed at Terminal A via the resistor divider network R1/R2 on the Sense pin of the IC. The voltage at the sense pin determines the duty cycle for the regulator. The voltage is adjusted by potentiometer R2. A relatively low voltage on the sense pin causes a long duty cycle that increases the field current. A high voltage results in a short duty cycle.

The ignition Terminal (I) switches power to the IC through the V_{CC} pin. The Stator pin monitors the voltage from the stator and senses a stopped engine condition. It drives the Lamp pin high after the stator timeout expires. The Lamp pin also goes high when an overvoltage condition

is detected on the sense pin. This causes the darlington lamp drive transistor to switch on and pull current through the lamp. If the system voltage continues to increase, the field and lamp output turn off as in an overvoltage or load dump condition.

The SC or Short Circuit pin monitors the field voltage. If the drive output and the SC voltage are simultaneously high for a predetermined period, a short circuit condition is assumed and the output is disabled. The regulator is forced to a minimum short circuit duty cycle.

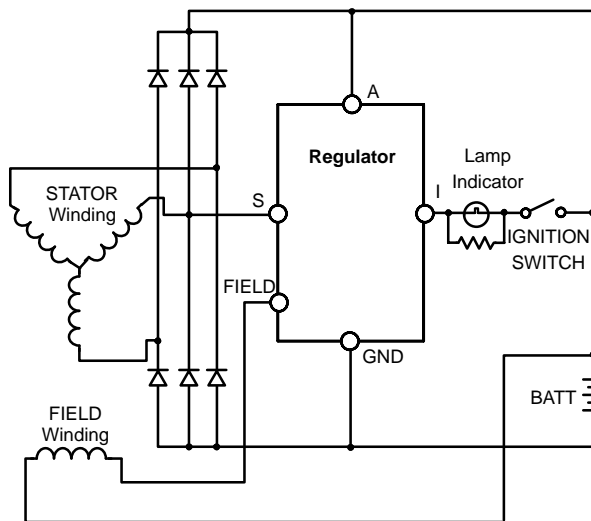

Figure 3. IAR System Block Diagram

REGULATION WAVEFORMS

The CS3361 utilizes proportion control to maintain regulation. Waveforms depicting operation are shown in Figures 4, 5 and 6, where $V_{BAT/N}$ is the divided down voltage present on the Sense pin using R1 and R2 (Figure 7). A sawtooth waveform is generated internally. The amplitude of this waveform is listed in the electric parameter section as proportion control. The oscillator voltage is summed with $V_{BAT/N}$, and compared with the internal voltage regulator (V_{REG}) in the regulation comparator which controls the field through the output "Device Driver."

Figure 4 shows typical steady-state operation. A 50% duty cycle is maintained.

Figure 5 shows the effect of a drop in voltage on ($V_{BAT/N} + V_{OSC}$). Notice the duty cycle increase to the field drive.

Figure 6 shows the effect of an increase in voltage (above the regulation voltage) on ($V_{BAT/N} + V_{OSC}$). Notice the decrease in field drive.

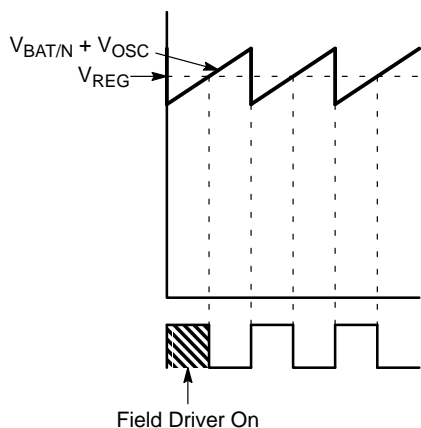

Figure 4. 50% Duty Cycle, Steady State

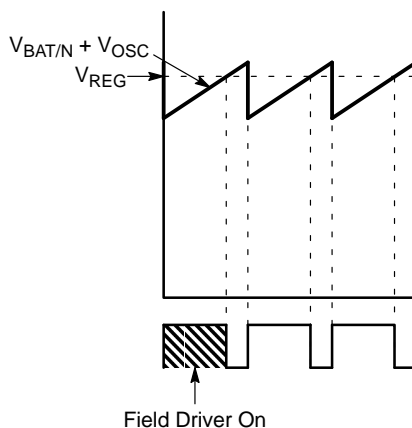

Figure 5. > 50% Duty Cycle, Increased Load

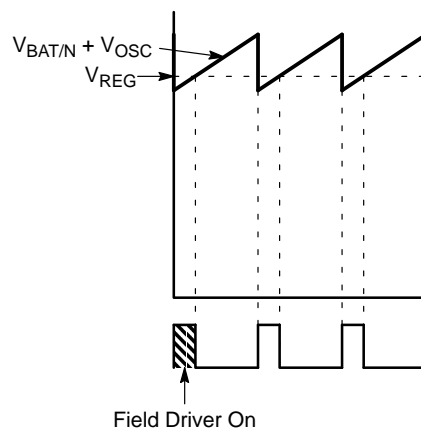

Figure 6. < 50% Duty Cycle, Decreased Load

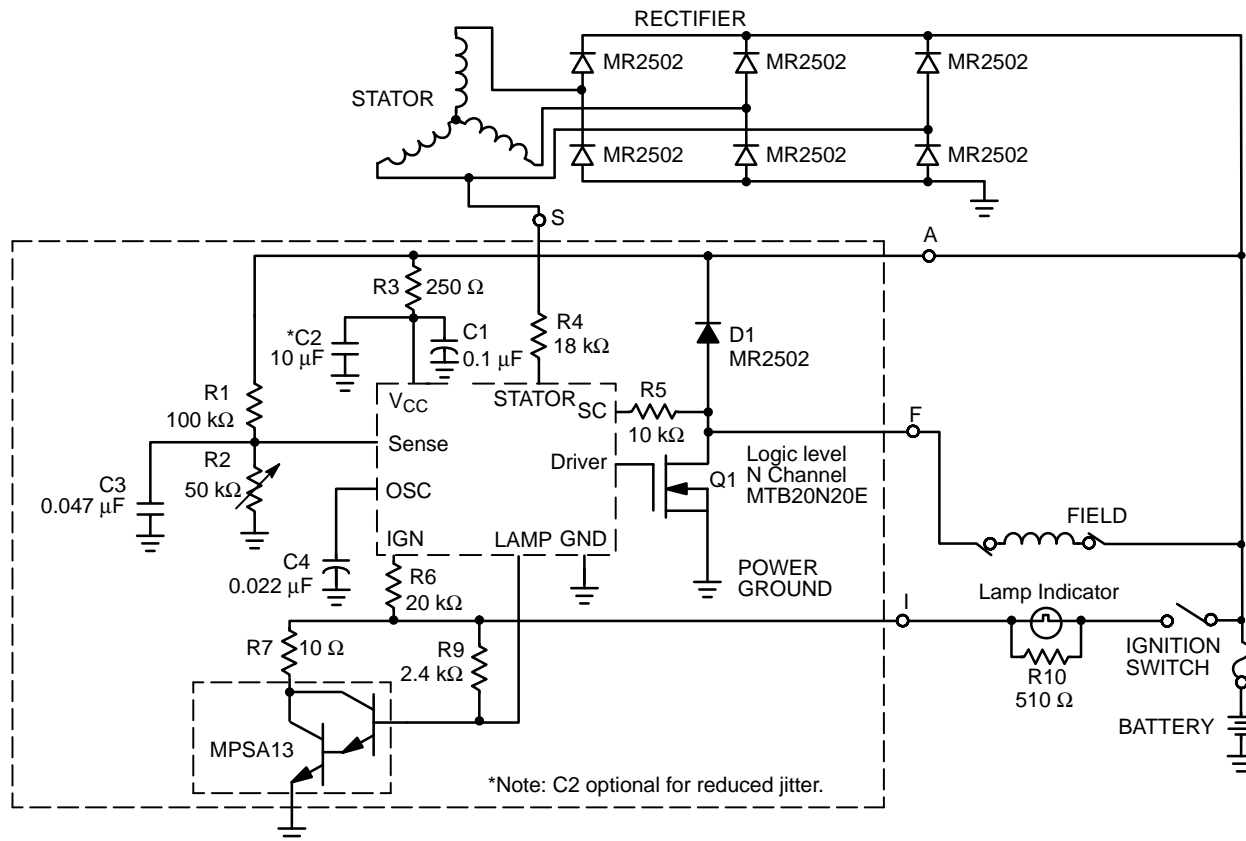
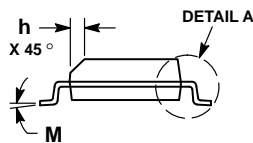
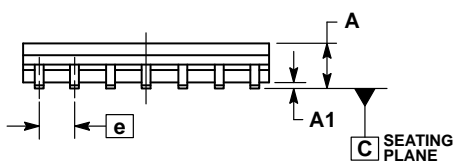
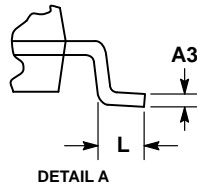
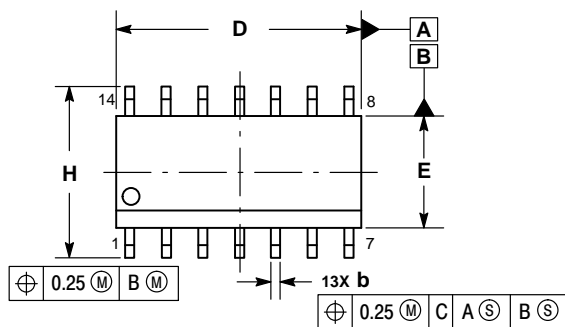

Figure 7. Typical Application Diagram

CS3361

PACKAGE DIMENSIONS

SOIC-14 NB CASE 751A-03 ISSUE K



NOTES:

1. DIMENSIONING AND TOLERANCING PER ASME Y14.5M, 1994.
2. CONTROLLING DIMENSION: MILLIMETERS.
3. DIMENSION b DOES NOT INCLUDE DAMBAR PROTRUSION. ALLOWABLE PROTRUSION SHALL BE 0.13 TOTAL IN EXCESS OF AT MAXIMUM MATERIAL CONDITION.
4. DIMENSIONS D AND E DO NOT INCLUDE MOLD PROTRUSIONS.
5. MAXIMUM MOLD PROTRUSION 0.15 PER SIDE.

DIM	MILLIMETERS		INCHES	
	MIN	MAX	MIN	MAX
A	1.35	1.75	0.054	0.068
A1	0.10	0.25	0.004	0.010
A3	0.19	0.25	0.008	0.010
b	0.35	0.49	0.014	0.019
D	8.55	8.75	0.337	0.344
E	3.80	4.00	0.150	0.157
e	1.27	BSC	0.050	BSC
H	5.80	6.20	0.228	0.244
h	0.25	0.50	0.010	0.019
L	0.40	1.25	0.016	0.049
M	0°	7°	0°	7°

SOLDERING FOOTPRINT*

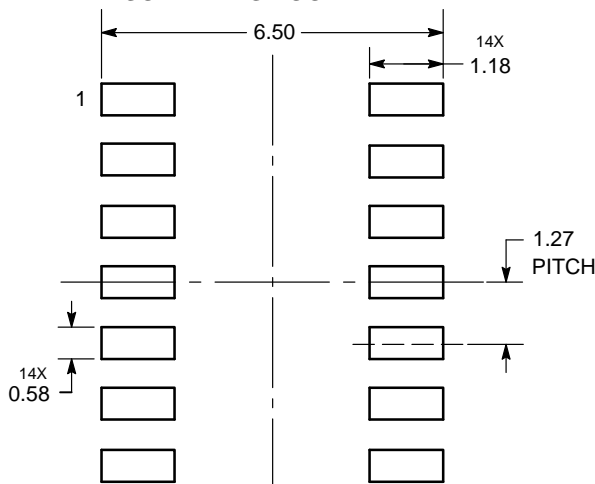

DIMENSIONS: MILLIMETERS

*For additional information on our Pb-Free strategy and soldering details, please download the ON Semiconductor Soldering and Mounting Techniques Reference Manual, SOLDERRM/D.

ON Semiconductor and the  are registered trademarks of Semiconductor Components Industries, LLC (SCILLC) or its subsidiaries in the United States and/or other countries. SCILLC owns the rights to a number of patents, trademarks, copyrights, trade secrets, and other intellectual property. A listing of SCILLC's product/patent coverage may be accessed at www.onsemi.com/site/pdf/Patent-Marking.pdf. SCILLC reserves the right to make changes without further notice to any products herein. SCILLC makes no warranty, representation or guarantee regarding the suitability of its products for any particular purpose, nor does SCILLC assume any liability arising out of the application or use of any product or circuit, and specifically disclaims any and all liability, including without limitation special, consequential or incidental damages. "Typical" parameters which may be provided in SCILLC data sheets and/or specifications can and do vary in different applications and actual performance may vary over time. All operating parameters, including "Typicals" must be validated for each customer application by customer's technical experts. SCILLC does not convey any license under its patent rights nor the rights of others. SCILLC products are not designed, intended, or authorized for use as components in systems intended for surgical implant into the body, or other applications intended to support or sustain life, or for any other application in which the failure of the SCILLC product could create a situation where personal injury or death may occur. Should Buyer purchase or use SCILLC products for any such unintended or unauthorized application, Buyer shall indemnify and hold SCILLC and its officers, employees, subsidiaries, affiliates, and distributors harmless against all claims, costs, damages, and expenses, and reasonable attorney fees arising out of, directly or indirectly, any claim of personal injury or death associated with such unintended or unauthorized use, even if such claim alleges that SCILLC was negligent regarding the design or manufacture of the part. SCILLC is an Equal Opportunity/Affirmative Action Employer. This literature is subject to all applicable copyright laws and is not for resale in any manner.

PUBLICATION ORDERING INFORMATION

LITERATURE FULFILLMENT:
Literature Distribution Center for ON Semiconductor
P.O. Box 5163, Denver, Colorado 80217 USA
Phone: 303-675-2175 or 800-344-3860 Toll Free USA/Canada
Fax: 303-675-2176 or 800-344-3867 Toll Free USA/Canada
Email: orderlit@onsemi.com

N. American Technical Support: 800-282-9855 Toll Free
USA/Canada
Europe, Middle East and Africa Technical Support:
Phone: 421 33 790 2910
Japan Customer Focus Center
Phone: 81-3-5817-1050

ON Semiconductor Website: www.onsemi.com
Order Literature: <http://www.onsemi.com/orderlit>

For additional information, please contact your local Sales Representative

X-ON Electronics

Largest Supplier of Electrical and Electronic Components

Click to view similar products for [Motor/Motion/Ignition Controllers & Drivers](#) category:

Click to view products by [ON Semiconductor](#) manufacturer:

Other Similar products are found below :

[LV8133JA-ZH](#) [LV8169MUTBG](#) [LV8774Q-AH](#) [LV8860PV-TLM-H](#) [MC33931EKR2](#) [FSB50250UTD](#) [FSB50550TB2](#) [FSBF15CH60BTH](#)
[FSBS10CH60T](#) [MP6507GR-P](#) [MP6508GF](#) [MSVGW54-14-5](#) [NTE7043](#) [CAT3211MUTAG](#) [LA6245P-CL-TLM-E](#) [LA6245P-TLM-E](#)
[LA6565VR-TLM-E](#) [LB11650-E](#) [LB1694N-E](#) [LB1837M-TLM-E](#) [LB1845DAZ-XE](#) [LC898111AXB-MH](#) [LC898300XA-MH](#) [SS30-TE-L-E](#)
[STK531-345A-E](#) [STK581U3A0D-E](#) [STK58AUNP0D-E](#) [STK621-068C-E](#) [STK621-140C](#) [STK621-728S-E](#) [STK625-728-E](#) [STK672-400B-E](#)
[STK672-432AN-E](#) [STK672-432BN-E](#) [STK672-440AN-E](#) [STK672-442AN-E](#) [AMIS30621AUA](#) [FSB50550ASE](#) [26700](#) [LV8161MUTAG](#)
[LV8281VR-TLM-H](#) [LV8702V-TLM-H](#) [LV8734VZ-TLM-H](#) [LV8773Z-E](#) [LV8807QA-MH](#) [MC33932EK](#) [MCP8024T-H/MP](#) [TND027MP-AZ](#)
[BA5839FP-E2](#) [MP6507GQ-P](#)