

PowerPact® H- and J-Frame Circuit Breakers

Catalog
0611CT0401R05/09

09
Class 0611



CONTENTS

Description	Page
General Information	Page 5
Mounting and Connections	Page 26
Accessories	Page 34
Wiring Diagrams	Page 45
Dimensions	Page 47
Trip Curves	Page 59
MCP Instantaneous Trip Points	Page 70



by Schneider Electric

PowerPact® H- and J-Frame Circuit Breakers

Table of Contents

SECTION 1: GENERAL INFORMATION	5
Introduction	5
Features and Benefits	5
Common Design Envelope	5
High Ampere Interrupting Ratings (AIR)	5
Dual-Break Rotating Contacts	6
Reduced Let-Through Currents	6
Internal Operating Mechanism	6
Handle Position Indication	6
Flexible Configurations	7
Field Installable Accessories and Trip Units	7
Catalog Numbering	8
Trip System (Trip Units)	9
H-Frame Trip Units	9
J-Frame Trip Units	10
Codes and Standards	10
Special Ratings	10
Suitable for Isolation (Positive Contact Indication)	11
Molded Case Circuit Breakers	11
Circuit Breaker Ratings	11
Marine Ratings	12
UL Marine Listed Circuit Breakers (UL489SA)	12
UL Naval Listed Circuit Breakers (UL 489 SB)	12
American Bureau of Shipping (ABS)	12
400 Hz Derating	12
Reverse Feeding of Circuit Breakers	12
Operating Conditions	13
Temperature	13
Altitude	13
Atmospheric Conditions	13
Vibration	13
Circuit Breaker Endurance	13
Corner Grounded Delta Ratings	13
Unit-Mount Circuit Breaker Catalog Numbers	15
I-Line Circuit Breaker Catalog Numbers	17
UL 489 SC Listed 500 Vdc Circuit Breakers	20
Electronic Motor Circuit Protectors	20
Full Load Amp Settings	21
Automatic Protection Settings	21
Manual Protection Settings	21
Automatic Molded Case Switches	24
 SECTION 2: MOUNTING AND CONNECTIONS	 26
Unit-Mount Circuit Breakers	26
Mounting	26
Mechanical Lugs	27
Bus-Bar Connections	28
Voltage Takeoff (Control Wire Terminals) for Mechanical Lugs and Terminal Nuts	28
Power Distribution Connectors	29
Compression Lugs	30
Terminal Shields	30
Rear Connections	31
I-Line® Circuit breakers	31
Plug-In and Drawout Circuit Breakers	32
Plug-In Circuit Breaker Mounting	32

PowerPact® H- and J-Frame Circuit Breakers

Table of Contents

Parts of a Plug-In Configuration	32
Drawout Circuit Breaker Mounting	33
Chassis Functions	33
SECTION 3: ACCESSORIES	34
Internal Accessories	34
Accessory Connections	34
Auxiliary and Alarm Switches	35
Shunt Trip (MX) and Undervoltage Trip (MN) Switches	36
Add-On Ground-Fault Module (GFM)	37
Earth Leakage Module (ELM) for PowerPact H- and J-Frame MCCBs	38
Motor Operator	39
Rotary Operating Handles	40
Directly-Mounted Rotary Operating Handles	40
Class 9421 NEMA Door Mounted Rotary Operating Handles	41
Class 9422 Cable Operating Handle	41
Variable Depth Mechanisms	42
Circuit Breaker Enclosures and Enclosure Accessories	42
Locking Systems	43
Interlocking Systems	44
Interlocking of Circuit Breakers With Toggle Control	44
Interlocking Two Circuit Breakers with Rotary Handles	44
SECTION 4: WIRING DIAGRAMS	45
Standard Motor Operator Wiring (Factory Wiring Configuration)	46
Remote Reset Wiring Without Overcurrent Trip Switch Protection	46
SECTION 5: DIMENSIONS	47
H-Frame Dimensional Drawings	47
J-Frame Dimensional Drawings	51
Plug-In H- and J-Frame Dimensional Drawings	53
Drawout H- and J-Frame Dimensional Drawings	54
Mounting Dimensional Drawings	55
H- and J-Frame Door Cutout Dimensional Drawings	56
SECTION 6: TRIP CURVES	59
SECTION 7: MCP INSTANTANEOUS TRIP POINTS	70

Section 1—General Information

Introduction

H-frame and J-frame molded case circuit breakers are designed to protect electrical systems from damage caused by overloads and short circuits. All circuit breakers are designed to open and close a circuit by nonautomatic means and to open the circuit automatically on a predetermined overcurrent.

Features and Benefits

The H- and J-frame modular platform provides many options for accessories, configurations, and actuation. H- and J-frame circuit breakers (15–250 A) and motor-circuit protectors (30–250 A) are designed to use common accessories. Some of the key features are defined below:

Common Design Envelope

Both the H-frame and J-frame circuit breakers feature common mounting holes, handle locations and trim dimensions.

Figure 1: Common Design for H- and J-Frame Circuit Breakers

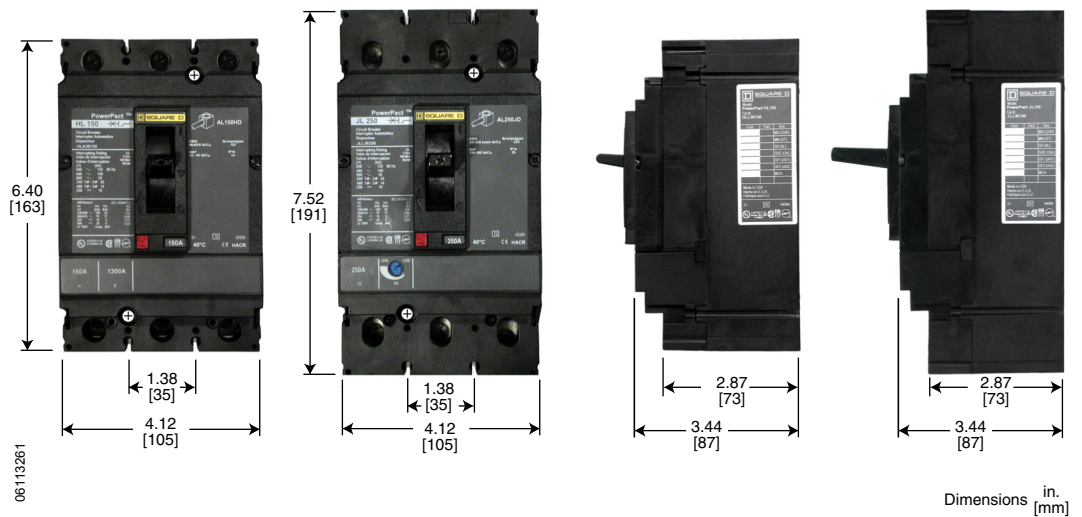

High Ampere Interrupting Ratings (AIR)

Circuit breakers are available with interrupting ratings up to:

- 125 kA at 240 Vac delta
- 100 kA at 480 Vac delta
- 50 kA at 600 Vac delta.

PowerPact® H- and J-Frame Circuit Breakers

Section 1—General Information

Dual-Break Rotating Contacts

All PowerPact® H-frame and J-frame circuit breakers are equipped with dual-break rotating contacts that reduce the amount of peak current during a short circuit fault. This reduces the let-through currents and enhances equipment protection.

Reduced Let-Through Currents

The moving contact has the shape of an elongated “S” and rotates around an floating axis. The shape of the fixed and moving contacts are such that the repelling forces appear as soon as the circuit reaches approximately 15 times I_n .

Due to the rotating movement, repulsion is rapid and the device greatly limits short-circuit currents, whatever the interrupting level of the unit (D, G, J or L). The fault current is extinguished before it can fully develop. Lower let-through currents provide less peak energy, reducing the required bus bar bracing, lowering enclosure pressure, and delivering improved series or combination ratings.

Special constructions are designed for continuous operation at 100% of their current rating. The 100% rated circuit breakers require a larger enclosure than the standard enclosures described on page 42.

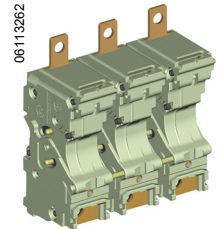
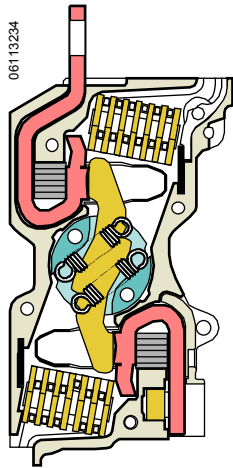

Internal Operating Mechanism

H-frame and J-frame circuit breakers have an over-center toggle mechanism providing quick-make, quick-break operation. The operating mechanism is also trip-free, which allows tripping even when the circuit breaker handle is held in the “ON” position.

Internal cross-bars provide common opening and closing of all poles with a single operating handle.

All H-frame and J-frame circuit breakers have an integral push-to-trip button in the cover to manually trip the circuit breaker. This should be used as part of a regular preventive maintenance program.

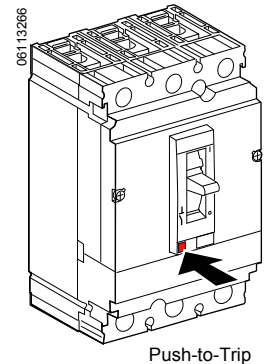

Handle Position Indication

The H-frame and J-frame circuit breaker handle can assume any of three positions, ON, tripped or OFF as shown. The center tripped position provides positive visual indication that the circuit breaker has tripped.

The circuit breaker can be reset by first pushing the handle to the extreme “OFF” position. Power can then be restored to the load by pushing the handle to the “ON” position.

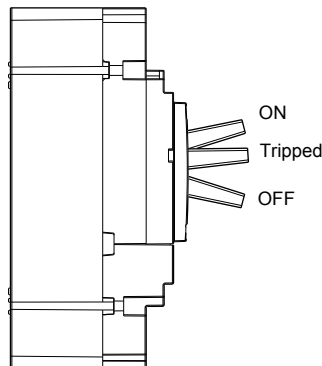

Flexible Configurations

The PowerPact H- and J-frame circuit breakers may be configured with lugs, bus bar connections, rear connections, I-Line®, drawout cradle, or plug-in base.

Field Installable Accessories and Trip Units

Figure 2: Field Installable Accessories and Trip Units

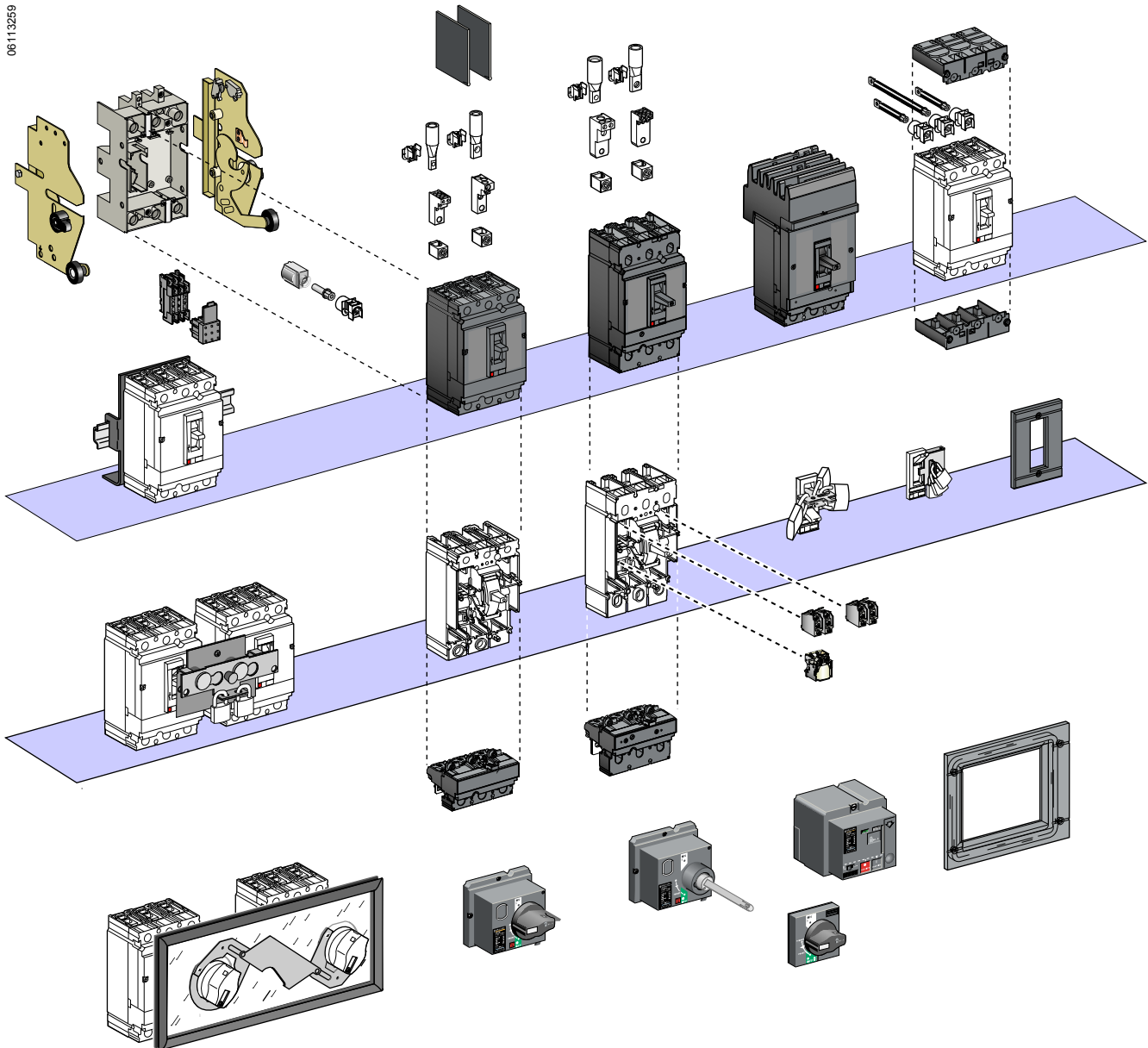

06113259

PowerPact® H- and J-Frame Circuit Breakers

Section 1—General Information

Catalog Numbering

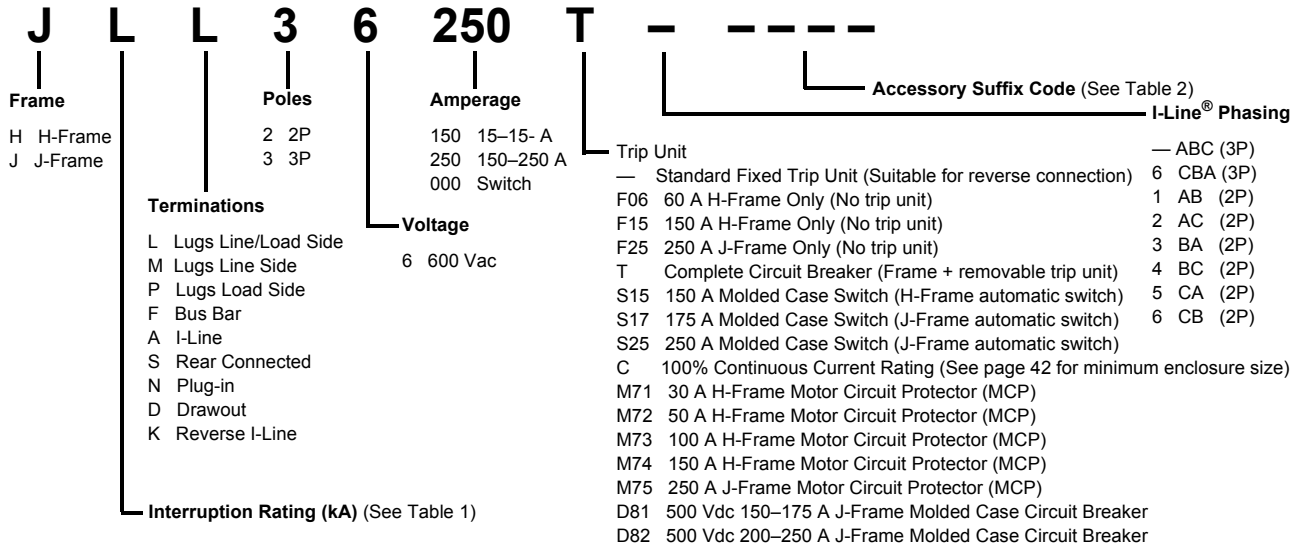

Table 1: Interrupting Rating

	UL/CSA/NOM					IEC 647-2 Icu/Ics				
	240 Vac	480 Vac	600 Vac	250 Vdc	500 Vdc ¹	220/240 Vac	380/440/415 Vac	500/525 Vac	250 Vdc	500 Vdc
D	25 kA	18 kA	14 kA	20 kA	—	25/25 kA	18/18 kA	14/14 kA	20 kA	20 kA
G	65 kA	35 kA	18 kA	20 kA	20 kA	65/65 kA	35/35 kA	18/18 kA	20 kA	20 kA
J	100 kA	65 kA	25 kA	20 kA	—	100/100 kA	65/65 kA	25/25 kA	20 kA	20 kA
L	125 kA	100 kA	50 kA	20 kA	—	125/125 kA	100/100 kA	50/50 kA	20 kA	20 kA

¹ Special DC J-frame circuit breakers only.

Table 2: Accessory Suffix Codes (Building Sequence as Listed)

(1) Auxiliary Switch			(3) Shunt Trip		(4) Undervoltage Release UVR		Voltage	(5) Motor Operator			
Suffix	Contacts	Kit Number	Suffix	Kit Number	Suffix	Kit Number		Suffix	Voltage	H-Frame	J-Frame
AA	1A/1B Standard	S29450	SK	S29384	UK	S29404	24 Vac	ML	48/60 Vac	S29440	S31548
AB	2A/2B Standard	S29450 (2)	SL	S29385	UL	S29405	48 Vac	MA	120 Vac	S29433	S31540
AE	1A/1B Gold	S29482	SA	S29386	UA	S29406	120 Vac	MD	277 Vac	S29434	S31541
AF	2A/2B Gold	S29482 (2)	SD	S29387	UD	S29407	208–277 Vac	MH	380/480 Vac	S29435	S31542
(2) Alarm/Overcurrent Trip Switch			SH	S29388	UH	S29408	380–480 Vac	MO	24/30 Vdc	S29436	S31543
BC	Alarm Switch (SD)	S29450	SJ	S29389	UJ	S29409	525–600 Vac	MP	48/60 Vdc	S29437	S31544
BH	Alarm Switch (SD) Low-level	S29452	SN	S29382	UN	S29402	12 Vdc	MR	110/130 Vdc	S29438	S31545
BD	SDE Standard	S29450 + S29451	SO	S29390	UO	S29410	24 Vdc	MS	250 Vdc	S29439	S31546
BJ	SDE Low-level	S29452 + S29451	SU	S29391	UU	S29411	30 Vdc	(6) IEC Style Rotary Handle			
BE	SD and SDE Standard	S29450 (2) + S29451	SP	S29392	UP	S29412	48 Vdc	Suffix	Handle Type (color)	Kit Number	
BK	SD and SDE Low-level	S29452 (2) + S29451	SV	S29383	UV	S29403	60 Vdc	RD10	Direct Mount (black)	S29337	
			SR	S29393	UR	S29413	125 Vdc	RE10	Extended Door Mount (black)	S29338	
			SS	S29394	US	S29414	250 Vdc	RT10	Telescoping (black)	S29343	
								RD20	Direct Mount (red)	S29339	
								RE20	Extended Door Mount (red)	S29340	

PowerPact® H- and J-Frame Circuit Breakers

Section 1—General Information

Trip System (Trip Units)

The H-frame and J-frame circuit breakers are equipped with a thermal-magnetic trip system designed to open automatically under overload or short circuit. H-frame and J-frame circuit breakers contain individual thermal (overload) and magnetic (short circuit) sensing elements in each pole.

The amperage ratings of the thermal trip elements are calibrated at 104°F (40°C) free air ambient temperature. Per the National Electric Code® (NEC®), circuit breakers may only be applied continuously at up to 80% of their rating.

Some models of the H- and J-frame circuit breakers are UL Listed to be applied at up to 100% of their current rating. Because of the additional heat generated, the use of specially-designed enclosures and 90°C rated wire is required when applying circuit breakers at 100% of continuous current rating. Markings on the circuit breaker indicate the minimum enclosure size and ventilation required. The 90°C wire must be sized according to the ampacities of the 75°C wire column in the NEC. Circuit breakers with 100% rating can also be used in applications requiring only 80% continuous loading.

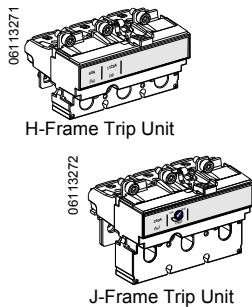

Table 3: H-Frame and J-Frame 3P Field-Installable Thermal-Magnetic Trip Unit

15–60 A H-Frame		70–150 A H-Frame		150–250 A J-Frame	
Amperage	Cat. No.	Amperage	Cat. No.	Amperage	Cat. No.
15 A	HT3015	70 A	HT3070	150 A	JT3150
20 A	HT3020	80 A	HT3080	175 A	JT3175
25 A	HT3025	90 A	HT3090	200 A	JT3200
30 A	HT3030	100 A	HT3100	225 A	JT3225
35 A	HT3035	110 A	HT3110	250 A	JT3250
40 A	HT3040	125 A	HT3125	—	—
45 A	HT3045	150 A	HT3150	—	—
50 A	HT3050	—	—	—	—
60 A	HT3060	—	—	—	—

H-Frame Trip Units

Table 4: Temperature Rerating (H-Frame Trip Unit Thermal Protection—Long-Time)

Temperature ¹		Rating (A) I _n															
°C	°F																
-10	14	23	30	38	46	53	60	68	76	88	103	112	123	137	160	180	221
0	32	21	28	36	43	49	56	63	71	83	97	107	117	131	151	171	207
10	50	20	26	33	40	46	52	59	66	77	90	101	111	126	141	161	194
20	68	18	24	31	37	42	48	54	62	72	84	96	105	120	132	152	180
30	86	17	22	28	34	39	44	50	56	66	77	88	98	110	121	139	165
40	104	15	20	25	30	35	40	45	50	60	70	80	90	100	110	125	150
50	122	12	17	21	25	30	34	38	43	53	62	72	80	86	95	109	131
60	140	9	14	17	20	24	28	31	35	46	53	63	70	72	80	93	111

¹ Shaded areas indicate temperature rerated values, non-shaded areas are standard circuit breaker ampere ratings at 40° C (104° F).

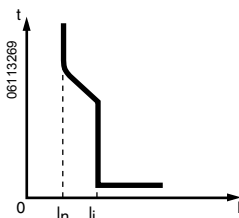

H-Frame Trip Curve

(I_n) Fixed threshold thermal protection against overload

(I_i) Fixed threshold magnetic protection against short circuits

Table 5: H-Frame Trip Unit Short Circuit Protection (Fixed) I_i

Ampere Rating	15–30 A	35–50 A	60–90 A	100–150 A
Hold (A)	350	400	800	900
Trip (A)	750	850	1450	1700

PowerPact® H- and J-Frame Circuit Breakers

Section 1—General Information

J-Frame Trip Units

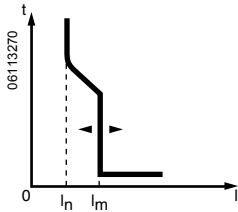

J-Frame Trip Unit

- (I_n) Fixed threshold thermal protection against overload
- (I_m) Adjustable magnetic protection against short circuits

Table 6: Temperature Rerating (J-Frame Trip Unit Thermal Protection—Long-Time)

Temperature ¹		Rating (A) I _n				
°C	°F					
-10	14	221	264	289	330	377
0	32	207	247	273	310	354
10	50	194	230	256	290	330
20	68	180	213	240	270	307
30	86	165	194	220	248	279
40	104	150	175	200	225	250
50	122	131	150	176	193	214
60	140	111	124	151	160	177

¹ Shaded areas indicate temperature rerated values, non-shaded areas are standard circuit breaker ampere ratings at 40° C (104° F).

Table 7: J-Frame Trip Unit Short Circuit Protection (Adjustable) I_m

Ampere Rating ¹	150 A	175 A	200 A	225 A	250 A
Low (A)	750	875	1000	1125	1250
High (A)	1500	1750	2000	2250	2500

¹ UL magnetic trip setting tolerances are -20% +30% from nominal values shown.

Codes and Standards

H- and J-frame circuit breakers, automatic switches and electronic motor circuit protectors are manufactured and tested in accordance with the following standards:

Table 8: Codes and Standards (Domestic)

NOTE: Apply circuit breakers according to guidelines detailed in the National Electric Code (NEC) and other local wiring codes.

PowerPact H- and J-Frame Circuit Breakers	H- and J-Frame Switches	PowerPact H- and J-Frame Motor Circuit Protectors
UL 489 ¹	UL 489 ³	UL 489 ¹
IEC Standard 60947-2	IEC Standard 60947-3	IEC Standard 60947-2
CSA 22.2 No. 5-02 ²	CSA 22.2 No. 5-02 ⁴	CSA 22.2 No. 5-02 ²
Federal Specification W-C-375B/GEN	Federal Specification W-C-375B/GEN	NEMA AB1
NEMA AB1	NEMA AB1	NMX J-515
NMX J-266	NMX J-266	CCC
NMX J-515	NMX J-515	CE Mark
UTE, VDE, BS, CEI, UNE	UTE, VDE, BS, CEI, UNE	
CCC	CCC	
CE Mark	CE Mark	

¹ PowerPact H- and J-frame circuit breakers and motor circuit protectors are in UL File E10027

² PowerPact H- and J-frame circuit breakers and motor circuit protectors are in CSA File LR40970

³ PowerPact H- and J-frame switches are in UL File E87159

⁴ PowerPact H- and J-frame switches are in CSA File LR32390

Special Ratings

The H-frame and J-frame circuit breakers also comply with the following special ratings:

- HACR rating
- SWD switch duty rating (applies only to 15 and 20 A / 277 Vac or less, 2P and 3P)
- HID high intensity discharge lighting rating (15–50 A)

Suitable for Isolation (Positive Contact Indication)

All PowerPact H-frame and J-frame circuit breakers and switches are suitable for isolation as defined in the IEC 60947-2 standard.

- The isolation position corresponds to the O (OFF position)
- The operating handle cannot indicate the OFF position unless the contacts are open
- Padlocks may not be installed unless the contacts are open

NOTE: Installation of a rotary handle or a motor mechanism does not alter the functionality of the position indication system.

The isolation function is certified by tests guaranteeing the mechanical reliability of the position indication system, the absence of leakage currents and the overvoltage withstand capacity between upstream and downstream connections.

Molded Case Circuit Breakers

Circuit Breaker Ratings

The interrupting rating is the highest current at rated voltage the circuit breaker is designed to safely interrupt under standard test conditions. Circuit breakers must be selected with interrupting ratings equal to or greater than the available short-circuit current at the point where the circuit breaker is applied to the system (unless it is a branch device in a series rated combination).

Interrupting ratings are shown on the front of the circuit breaker.

Table 9: UL 489 Circuit Breaker Ratings

		150 A H-Frame				250 A J-Frame			
Circuit Breaker Type		HD	HG	HJ	HL	JD	JG	JJ	JL
Number of Poles		2, 3	2, 3	2, 3	2, 3	2, 3	2, 3	2, 3	2, 3
Amperage Range (A)		15–150	15–150	15–150	15–150	150–250	150–250	150–250	150–250
UL/CSA/NOM (kA)	240 Vac	25	65	100	125	25	65	100	125
	480 Vac	18	35	65	100	18	35	65	100
	600 Vac	14	18	25	50	14	18	25	50
	250 Vdc	20	20	20	20	20	20	20	20
	500 Vdc ¹	—	—	—	—	20	20	20	20

¹ 500 Vdc rating applies only to catalog numbers with suffix D81 or D82, meeting UL489SC (Supplement C).

Table 10: IEC 60947-2 Circuit Breaker Ratings

		150 A H-Frame				250 A J-Frame			
Circuit Breaker Type		HD	HG	HJ	HL	JD	JG	JJ	JL
Number of Poles		2, 3	2, 3	2, 3	2, 3	2, 3	2, 3	2, 3	2, 3
Amperage Range (A)		15–150	15–150	15–150	15–150	150–250	150–250	150–250	150–250
IEC 60947-2 I_{cu}/I_{cs} (kA)	220/240 Vac	25/25	65/65	100/100	125/125	25/25	65/65	100/100	125/125
	380/440/415 Vac	18/18	35/35	65/65	100/100	18/18	35/35	65/65	100/100
	500/525 Vac	14/14	18/18	25/25	50/50	14/14	18/18	25/25	50/50
	250 Vdc	20	20	20	20	20	20	20	20
	500 Vdc ^{1, 2}	20	20	20	20	20	20	20	20
Insulation Voltage	U_i	750 Vac				750 Vac			
Impulse Withstand Voltage	U_{imp}	8 kVac				8 kVac			
Operational Voltage	U_e	525 Vac				525 Vac			
Rated Current	I_n	150 A				250 A			
Utilization Category	—	A				A			

¹ 2P in series

² 500 Vdc rating applies only to catalog numbers with suffix D81 or D82, meeting UL489SC (Supplement C).

PowerPact® H- and J-Frame Circuit Breakers

Section 1—General Information

Marine Ratings

UL Marine Listed Circuit Breakers (UL489SA)

A standard for molded case circuit breakers which are intended to be installed and used aboard a boat or vessel is included in Supplement SA SB to UL 489, “Standard for Molded Case Circuit Breakers and Circuit Breaker Enclosures” (also referred to as UL product category DKTY). This UL Standard was established in accordance with U.S. Coast Guard regulations, applicable American Boat and Yacht Council Inc. publications, and NFPA® 302 “Standard for Motor Craft (Pleasure and Commercial)”. In order to be UL Listed for marine use, circuit breakers must not use aluminum or aluminum alloys for terminal connections and must be calibrated at an ambient temperature of 40°C. Standard circuit breakers should not be specified or used in place of marine circuit breakers.

The PowerPact H and J-frame circuit breakers are UL 489 SA and SB Marine Listed for use on vessels over 65 ft. (19.8 m) in length and under 65 ft. [19.8 m] in length.) These breakers can be added by ordering with the suffix “YA” which includes the required copper lugs.

UL Naval Listed Circuit Breakers (UL 489 SB)

The standard for molded case circuit breakers which are intended or use aboard non-combatant and auxiliary naval ships is included in Supplement SB to UL 489, “Standard for Molded Case Circuit Breakers and Circuit Breaker Enclosures”. The PowerPact H and J-frame circuit breakers are UL 489 SB are UL Naval Listed for use on vessels over 65 ft. (19.8 m) in length and under 65 feet (19.8 m) in length. These breakers can be added by ordering with the suffix “YA” which includes the required copper lugs.

American Bureau of Shipping (ABS)

The PowerPact H- and J-Frame circuit breakers are certified to ABSNVR (American Bureau of Shipping - Naval Vessel Rules), for use on Naval vessels.

400 Hz Derating

Application of thermal-magnetic circuit breakers at frequencies above 60 Hz requires that special consideration be given to the effects of high frequency on the circuit breaker characteristics. Thermal and magnetic operations must be treated separately.

At frequencies below 60 Hz, the thermal rerating of thermal-magnetic circuit breakers is negligible. However, at frequencies above 60 Hz, thermal rerating is required.

One of the most common high frequency applications is at 400 Hz.

Table 11: 400 Hz Derating

Circuit Breaker	400 Hz Derating Multiplier
H-Frame	0.95
J-Frame	0.90

For more information, refer to Data Bulletin 0100DB0101, *Determining Current Carrying Capacity in Special Applications*.

Reverse Feeding of Circuit Breakers

The standard unit-mount H- and J-frame circuit breakers have sealed trip units and may be reverse fed. See Tables 15–18 for catalog numbers.

Circuit breakers with field-interchangeable trip units (designated by the suffix T and labeled “LINE” and “LOAD”) cannot be reverse fed. Neither can circuit breaker frames without terminations or trip units. See Tables 19–21.

PowerPact® H- and J-Frame Circuit Breakers

Section 1—General Information

Operating Conditions

Temperature

To meet the requirements of the UL489 Standard, molded case circuit breakers are designed, built and calibrated for use on 50/60 Hz ac systems in a 40°C (104°F) ambient environment. The thermal-magnetic system is affected by changes in ambient temperature and the circuit breaker may require re-rating to suit the environment it operates within. The circuit breaker may be operated at temperatures between -25°C (-13°F) and +70°C (158° F). For temperature rerating tables, see Table 4 and Table 6.

NOTE: A special 50°C (122° F) Rating is available for special high ambient conditions (not UL listed). Order by adding CA suffix to catalog number.

Altitude

Circuit breakers are suitable for use at altitudes up to 13,100 ft. (4000 m). For altitudes higher than 6560 ft. (2000 m), circuit breakers must be rerated as shown.

Table 12: Altitude Rerating Values per ANSI C37.20.1 (table 10)

Altitude	≤ 6,600 ft. (≤ 2,000 m)	8,500 ft. (2,600 m)	13,000 ft. (3,900 m)
Voltage	1.00	0.95	0.80
Current	1.00	0.99	0.96

Atmospheric Conditions

The materials used in PowerPact circuit breakers will not support the growth of fungus and mold.

Vibration

PowerPact H- and J-frame circuit breakers meet IEC 60068-2-6 Standards for vibration:

- 2.0 Hz to 25 Hz - amplitude +/- 1.6 mm
- 25.0 Hz to 100 Hz - acceleration +/- 4.0 g

Circuit Breaker Endurance

Table 13: Operations (Open-Close Cycles)

Frame	Number of Operations	
	With Current	Without Current
150 A H-Frame	4000	4000
250 A J-Frame	1000	5000

Corner Grounded Delta Ratings (1Ø-3Ø)

Circuit breakers suitable for corner-grounded circuits are marked 1Ø-3Ø. For additional information, refer to data bulletin 2700DB0202R2/09.

Table 14: Corner Grounded Delta Ratings (1Ø-3Ø)

	2P H-Frame				2P J-Frame				3P H-Frame				3P J-Frame			
	HD	HG	HJ ¹	HL ¹	JD ¹	JG ¹	JJ ¹	JL ¹	HD	HG	HJ	HL	JD	JG	JJ	JL
Ampere Rating (A)	15–150				150–250				15–150				150–250			
Voltage Rating (Vac)	240				240				480				480			
UL Interrupting Rating (kA)	42	42	65	100	42	42	65	100	18	35	65	100	18	35	65	100

¹ Built using 3P module

PowerPact® H- and J-Frame Circuit Breakers

Section 1—General Information

Figure 3: Three-Phase 240 Vac Corner-Grounded Delta System

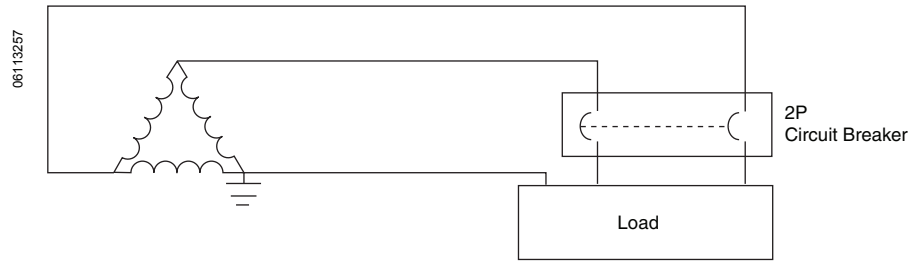

NOTE: Three-pole circuit breakers must be used on three-phase 480 Vac corner-grounded delta systems. See Figure 2. The outside poles are to be connected to the ungrounded phases and the grounded conductor connected to the center poles. Connecting the circuit breaker in a manner other than that described or shown may result in an unsafe application of the circuit breaker.

Figure 4: Three-Phase 480 Vac Corner-Grounded Delta System

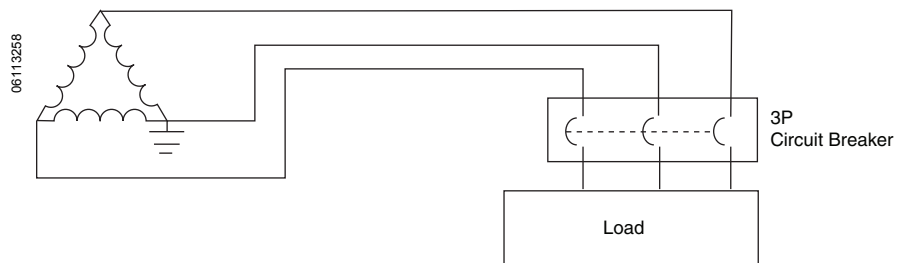

PowerPact® H- and J-Frame Circuit Breakers
Section 1—General Information

Unit-Mount Circuit Breaker Catalog Numbers

Table 15: PowerPact H-Frame 150 A Unit-Mount Thermal-Magnetic Current Limiting Circuit Breakers (600 Vac, 250 Vdc) with Factory Sealed Trip Unit (Suitable for Reverse Connection)

Current Rating @ 40 C	Fixed AC Magnetic Trip		Interrupting Rating								Terminal Wire Range
			D		G		J		L		
	Hold	Trip	80% Rated	100% Rated	80% Rated	100% Rated	80% Rated	100% Rated	80% Rated	100% Rated	
H-Frame, 150 A, 2P, 600 Vac 50/60Hz, 250 Vdc											
15 A	350 A	750 A	HDL26015	HDL26015C	HGL26015	HGL26015C	HJL26015	HJL26015C	HLL26015	HLL26015C	AL 150HD 14–3/0 AWG Al or Cu
20 A	350 A	750 A	HDL26020	HDL26020C	HGL26020	HGL26020C	HJL26020	HJL26020C	HLL26020	HLL26020C	
25 A	350 A	750 A	HDL26025	HDL26025C	HGL26025	HGL26025C	HJL26025	HJL26025C	HLL26025	HLL26025C	
30 A	350 A	750 A	HDL26030	HDL26030C	HGL26030	HGL26030C	HJL26030	HJL26030C	HLL26030	HLL26030C	
35 A	400 A	850 A	HDL26035	HDL26035C	HGL26035	HGL26035C	HJL26035	HJL26035C	HLL26035	HLL26035C	
40 A	400 A	850 A	HDL26040	HDL26040C	HGL26040	HGL26040C	HJL26040	HJL26040C	HLL26040	HLL26040C	
45 A	400 A	850 A	HDL26045	HDL26045C	HGL26045	HGL26045C	HJL26045	HJL26045C	HLL26045	HLL26045C	
50 A	400 A	850 A	HDL26050	HDL26050C	HGL26050	HGL26050C	HJL26050	HJL26050C	HLL26050	HLL26050C	
60 A	800 A	1450 A	HDL26060	HDL26060C	HGL26060	HGL26060C	HJL26060	HJL26060C	HLL26060	HLL26060C	
70 A	800 A	1450 A	HDL26070	HDL26070C	HGL26070	HGL26070C	HJL26070	HJL26070C	HLL26070	HLL26070C	
80 A	800 A	1450 A	HDL26080	HDL26080C	HGL26080	HGL26080C	HJL26080	HJL26080C	HLL26080	HLL26080C	
90 A	800 A	1450 A	HDL26090	HDL26090C	HGL26090	HGL26090C	HJL26090	HJL26090C	HLL26090	HLL26090C	
100 A	900 A	1700 A	HDL26100	HDL26100C	HGL26100	HGL26100C	HJL26100	HJL26100C	HLL26100	HLL26100C	
110 A	900 A	1700 A	HDL26110	HDL26110C	HGL26110	HGL26110C	HJL26110	HJL26110C	HLL26110	HLL26110C	
125 A	900 A	1700 A	HDL26125	HDL26125C	HGL26125	HGL26125C	HJL26125	HJL26125C	HLL26125	HLL26125C	
150 A	900 A	1700 A	HDL26150	HDL26150C	HGL26150	HGL26150C	HJL26150	HJL26150C	HLL26150	HLL26150C	
H-Frame, 150 A, 3P, 600 Vac 50/60Hz, 250 Vdc											
15 A	350 A	750 A	HDL36015	HDL36015C	HGL36015	HGL36015C	HJL36015	HJL36015C	HLL36015	HLL36015C	AL 150HD 14–3/0 AWG Al or Cu
20 A	350 A	750 A	HDL36020	HDL36020C	HGL36020	HGL36020C	HJL36020	HJL36020C	HLL36020	HLL36020C	
25 A	350 A	750 A	HDL36025	HDL36025C	HGL36025	HGL36025C	HJL36025	HJL36025C	HLL36025	HLL36025C	
30 A	350 A	750 A	HDL36030	HDL36030C	HGL36030	HGL36030C	HJL36030	HJL36030C	HLL36030	HLL36030C	
35 A	400 A	850 A	HDL36035	HDL36035C	HGL36035	HGL36035C	HJL36035	HJL36035C	HLL36035	HLL36035C	
40 A	400 A	850 A	HDL36040	HDL36040C	HGL36040	HGL36040C	HJL36040	HJL36040C	HLL36040	HLL36040C	
45 A	400 A	850 A	HDL36045	HDL36045C	HGL36045	HGL36045C	HJL36045	HJL36045C	HLL36045	HLL36045C	
50 A	400 A	850 A	HDL36050	HDL36050C	HGL36050	HGL36050C	HJL36050	HJL36050C	HLL36050	HLL36050C	
60 A	800 A	1450 A	HDL36060	HDL36060C	HGL36060	HGL36060C	HJL36060	HJL36060C	HLL36060	HLL36060C	
70 A	800 A	1450 A	HDL36070	HDL36070C	HGL36070	HGL36070C	HJL36070	HJL36070C	HLL36070	HLL36070C	
80 A	800 A	1450 A	HDL36080	HDL36080C	HGL36080	HGL36080C	HJL36080	HJL36080C	HLL36080	HLL36080C	
90 A	800 A	1450 A	HDL36090	HDL36090C	HGL36090	HGL36090C	HJL36090	HJL36090C	HLL36090	HLL36090C	
100 A	900 A	1700 A	HDL36100	HDL36100C	HGL36100	HGL36100C	HJL36100	HJL36100C	HLL36100	HLL36100C	
110 A	900 A	1700 A	HDL36110	HDL36110C	HGL36110	HGL36110C	HJL36110	HJL36110C	HLL36110	HLL36110C	
125 A	900 A	1700 A	HDL36125	HDL36125C	HGL36125	HGL36125C	HJL36125	HJL36125C	HLL36125	HLL36125C	
150 A	900 A	1700 A	HDL36150	HDL36150C	HGL36150	HGL36150C	HJL36150	HJL36150C	HLL36150	HLL36150C	

PowerPact® H- and J-Frame Circuit Breakers

Section 1—General Information

Table 16: PowerPact J-Frame 250 A Unit-Mount Thermal-Magnetic Current Limiting Circuit Breakers with Factory Sealed Trip Unit (Suitable for Reverse Connection)

Current Rating @ 40 C	Fixed AC Magnetic Trip		Interrupting Rating								Terminal Wire Range
			D		G		J		L		
	Hold	Trip	80% Rated	100% Rated	80% Rated	100% Rated	80% Rated	100% Rated	80% Rated	100% Rated	
J-Frame, 250 A, 2P, 600 Vac 50/60Hz, 250 Vdc											
150 A	750 A	1500 A	JDL36150	JDL36150C	JGL36150	JGL36150C	JJL36150	JJL36150C	JLL36150	JLL36150C	AL175JD 4–4/0 AWG Al or Cu
175 A	875 A	1750 A	JDL36175	JDL36175C	JGL36175	JGL36175C	JJL36175	JJL36175C	JLL36175	JLL36175C	
200 A	1000 A	2000 A	JDL36200	JDL36200C	JGL36200	JGL36200C	JJL36200	JJL36200C	JLL36200	JLL36200C	AL250JD 3/0 AWG–350 kcmil Al or Cu
225 A	1125 A	2250 A	JDL36225	JDL36225C	JGL36225	JGL36225C	JJL36225	JJL36225C	JLL36225	JLL36225C	
250 A	1250 A	2500 A	JDL36250	JDL36250C	JGL36250	JGL36250C	JJL36250	JJL36250C	JLL36250	JLL36250C	
J-Frame, 250 A, 3P, 600 Vac 50/60Hz, 250 Vdc											
150 A	750 A	1500 A	JDL36150	JDL36150C	JGL36150	JGL36150C	JJL36150	JJL36150C	JLL36150	JLL36150C	AL175JD 4–4/0 AWG Al or Cu
175 A	875 A	1750 A	JDL36175	JDL36175C	JGL36175	JGL36175C	JJL36175	JJL36175C	JLL36175	JLL36175C	
200 A	1000 A	2000 A	JDL36200	JDL36200C	JGL36200	JGL36200C	JJL36200	JJL36200C	JLL36200	JLL36200C	AL250JD 3/0 AWG–350 kcmil Al or Cu
225 A	1125 A	2250 A	JDL36225	JDL36225C	JGL36225	JGL36225C	JJL36225	JJL36225C	JLL36225	JLL36225C	
250 A	1250 A	2500 A	JDL36250	JDL36250C	JGL36250	JGL36250C	JJL36250	JJL36250C	JLL36250	JLL36250C	

PowerPact® H- and J-Frame Circuit Breakers

Section 1—General Information

I-Line Circuit Breaker Catalog Numbers

Table 17: PowerPact H-Frame 150 A I-Line® Thermal-Magnetic Current Limiting Circuit Breakers with Factory Sealed Trip Unit (Suitable for Reverse Connection)

Current Rating @ 40 C	Fixed AC Magnetic Trip		Interrupting Rating ¹				Terminal Wire Range
			D	G	J	L	
	Hold	Trip	80% Rated	80% Rated	80% Rated	80% Rated	
H-Frame, 150 A, 2P, 600 Vac 50/60Hz, 250 Vdc							
15 A	350 A	750 A	HDA26015()	HGA26015()	HJA26015()	HLA26015()	AL150HD 14-3/0 AWG Al or Cu
20 A	350 A	750 A	HDA26020()	HGA26020()	HJA26020()	HLA26020()	
25 A	350 A	750 A	HDA26025()	HGA26025()	HJA26025()	HLA26025()	
30 A	350 A	750 A	HDA26030()	HGA26030()	HJA26030()	HLA26030()	
35 A	400 A	850 A	HDA26035()	HGA26035()	HJA26035()	HLA26035()	
40 A	400 A	850 A	HDA26040()	HGA26040()	HJA26040()	HLA26040()	
45 A	400 A	850 A	HDA26045()	HGA26045()	HJA26045()	HLA26045()	
50 A	400 A	850 A	HDA26050()	HGA26050()	HJA26050()	HLA26050()	
60 A	800 A	1450 A	HDA26060()	HGA26060()	HJA26060()	HLA26060()	
70 A	800 A	1450 A	HDA26070()	HGA26070()	HJA26070()	HLA26070()	
80 A	800 A	1450 A	HDA26080()	HGA26080()	HJA26080()	HLA26080()	
90 A	800 A	1450 A	HDA26090()	HGA26090()	HJA26090()	HLA26090()	
100 A	900 A	1700 A	HDA26100()	HGA26100()	HJA26100()	HLA26100()	
110 A	900 A	1700 A	HDA26110()	HGA26110()	HJA26110()	HLA26110()	
125 A	900 A	1700 A	HDA26125()	HGA26125()	HJA26125()	HLA26125()	
150 A	900 A	1700 A	HDA26150()	HGA26150()	HJA26150()	HLA26150()	
H-Frame, 150 A, 3P, 600 Vac 50/60Hz, 250 Vdc							
15 A	350 A	750 A	HDA36015	HGA36015	HJA36015	HLA36015	AL150HD 14-3/0 AWG Al or Cu
20 A	350 A	750 A	HDA36020	HGA36020	HJA36020	HLA36020	
25 A	350 A	750 A	HDA36025	HGA36025	HJA36025	HLA36025	
30 A	350 A	750 A	HDA36030	HGA36030	HJA36030	HLA36030	
35 A	400 A	850 A	HDA36035	HGA36035	HJA36035	HLA36035	
40 A	400 A	850 A	HDA36040	HGA36040	HJA36040	HLA36040	
45 A	400 A	850 A	HDA36045	HGA36045	HJA36045	HLA36045	
50 A	400 A	850 A	HDA36050	HGA36050	HJA36050	HLA36050	
60 A	800 A	1450 A	HDA36060	HGA36060	HJA36060	HLA36060	
70 A	800 A	1450 A	HDA36070	HGA36070	HJA36070	HLA36070	
80 A	800 A	1450 A	HDA36080	HGA36080	HJA36080	HLA36080	
90 A	800 A	1450 A	HDA36090	HGA36090	HJA36090	HLA36090	
100 A	900 A	1700 A	HDA36100	HGA36100	HJA36100	HLA36100	
110 A	900 A	1700 A	HDA36110	HGA36110	HJA36110	HLA36110	
125 A	900 A	1700 A	HDA36125	HGA36125	HJA36125	HLA36125	
150 A	900 A	1700 A	HDA36150	HGA36150	HJA36150	HLA36150	

¹() Indicate phasing

PowerPact® H- and J-Frame Circuit Breakers

Section 1—General Information

Table 18: PowerPact J-Frame 250A I-Line Thermal-Magnetic Current Limiting Circuit Breakers with Factory Sealed Trip Unit (Suitable for Reverse Connection)

Current Rating @ 40 C	Fixed AC Magnetic Trip		Interrupting Rating ¹				Terminal Wire Range
			D	G	J	L	
	Hold	Trip	80% Rated	80% Rated	80% Rated	80% Rated	
J-Frame, 250 A, 2P, 600 Vac 50/60Hz, 250 Vdc							
150 A	750 A	1500 A	JDA36150()	JGA36150()	JJA36150()	JLA36150()	AL175JD 4-4/0 AWG Al or Cu
175 A	875 A	1750 A	JDA36175()	JGA36175()	JJA36175()	JLA36175()	
200 A	1000 A	2000 A	JDA36200()	JGA36200()	JJA36200()	JLA36200()	AL250JD 3/0 AWG-350 kcmil Al or Cu
225 A	1125 A	2250 A	JDA36225()	JGA36225()	JJA36225()	JLA36225()	
250 A	1250 A	2500 A	JDA36250()	JGA36250()	JJA36250()	JLA36250()	
J-Frame, 250 A, 3P, 600 Vac 50/60Hz, 250 Vdc							
150 A	750 A	1500 A	JDA36150	JGA36150	JJA36150	JLA36150	AL175JD 4-4/0 AWG Al or Cu
175 A	875 A	1750 A	JDA36175	JGA36175	JJA36175	JLA36175	
200 A	1000 A	2000 A	JDA36200	JGA36200	JJA36200	JLA36200	AL250JD 3/0 AWG-350 kcmil Al or Cu
225 A	1125 A	2250 A	JDA36225	JGA36225	JJA36225	JLA36225	
250 A	1250 A	2500 A	JDA36250	JGA36250	JJA36250	JLA36250	

¹() Indicate phasing

Circuit Breakers with Field-Interchangeable Trip Units

Table 19: H-Frame 150 A Current-Limiting Circuit Breaker Frame with Field-Interchangeable Thermal-Magnetic Trip Units¹ (3P, 600 Vac, 250 Vdc)

Ampere Rating	Fixed AC Magnetic Trip		Interrupting Rating				Terminal Wire Range
			D	G	J	L	
	Hold	Trip	Cat. No.	Cat. No.	Cat. No.	Cat. No.	
15 A	350 A	750 A	HDL36015T	HGL36015T	HJL36015T	HLL36015T	AL150HD 14-3/0 AWG Al or Cu
20 A	350 A	750 A	HDL36020T	HGL36020T	HJL36020T	HLL36020T	
25 A	350 A	750 A	HDL36025T	HGL36025T	HJL36025T	HLL36025T	
30 A	350 A	750 A	HDL36030T	HGL36030T	HJL36030T	HLL36030T	
35 A	400 A	850 A	HDL36035T	HGL36035T	HJL36035T	HLL36035T	
40 A	400 A	850 A	HDL36040T	HGL36040T	HJL36040T	HLL36040T	
45 A	400 A	850 A	HDL36045T	HGL36045T	HJL36045T	HLL36045T	
50 A	400 A	850 A	HDL36050T	HGL36050T	HJL36050T	HLL36050T	
60 A	800 A	1450 A	HDL36060T	HGL36060T	HJL36060T	HLL36060T	
70 A	800 A	1450 A	HDL36070T	HGL36070T	HJL36070T	HLL36070T	
80 A	800 A	1450 A	HDL36080T	HGL36080T	HJL36080T	HLL36080T	
90 A	800 A	1450 A	HDL36090T	HGL36090T	HJL36090T	HLL36090T	
100 A	900 A	1700 A	HDL36100T	HGL36100T	HJL36100T	HLL36100T	
110 A	900 A	1700 A	HDL36110T	HGL36110T	HJL36110T	HLL36110T	
125 A	900 A	1700 A	HDL36125T	HGL36125T	HJL36125T	HLL36125T	
150 A	900 A	1700 A	HDL36150T	HGL36150T	HJL36150T	HLL36150T	

¹ Circuit breakers will be labeled with Line and Load markings and are not suitable for reverse connections. Only available on standard (80%) rated 3P unit-mount circuit breakers; not available with I-Line® or Plug-In constructions.

PowerPact® H- and J-Frame Circuit Breakers

Section 1—General Information

Table 20: J-Frame 250 A Current-Limiting Circuit Breaker Frame with Field-Interchangeable Thermal-Magnetic Trip Units¹ (3P, 600 Vac, 250 Vdc)

Ampere Rating	Adjustable AC Magnetic Trip		Interrupting Rating				Terminal Wire Range
			D	G	J	L	
	Low	High	Cat. No.	Cat. No.	Cat. No.	Cat. No.	
150 A	750 A	1500 A	JDL36150T	JGL36150T	JJL36150T	JLL36150T	AL175JD
175 A	875 A	1750 A	JDL36175T	JGL36175T	JJL36175T	JLL36175T	4--4/0 AWG Al or Cu
200 A	1000 A	2000 A	JDL36200T	JGL36200T	JJL36200T	JLL36200T	AL250JD 3/0 AWG–350 kcmil Al or Cu
225 A	1125 A	2250 A	JDL36225T	JGL36225T	JJL36225T	JLL36225T	
250 A	1250 A	2500 A	JDL36250T	JGL36250T	JJL36250T	JLL36250T	

¹ Circuit breakers will be labeled with Line and Load markings and are not suitable for reverse connections. Only available on standard (80%) rated 3P unit-mount circuit breakers; not available with I-Line® or Plug-In constructions.

Table 21: H-Frame 150A and J-Frame 250 A 3P Basic Current-Limiting Circuit Breaker Frame Without Terminations or Trip Unit (600 Vac, 250 Vdc)

Circuit Breaker Frame	Ampere Rating	Interrupting Rating			
		D	G	J	L
		Cat. No.	Cat. No.	Cat. No.	Cat. No.
H-Frame	15–60 A	HDF36000F06	HGF36000F06	HJF36000F06	HLF36000F06
	70–150 A	HDF36000F15	HGF36000F15	HJF36000F15	HLF36000F15
J-Frame	150–250 A	JDF36000F25	JGF36000F25	JJF36000F25	JLF36000F25

Table 22: H-Frame and J-Frame 3P Field-Installable Thermal-Magnetic Trip Unit

15–60 A H-Frame		70–150 A H-Frame		150–250 A J-Frame	
Amperage	Cat. No.	Amperage	Cat. No.	Amperage	Cat. No.
15 A	HT3015	70 A	HT3070	150 A	JT3150
20 A	HT3020	80 A	HT3080	175 A	JT3175
25 A	HT3025	90 A	HT3090	200 A	JT3200
30 A	HT3030	100 A	HT3100	225 A	JT3225
35 A	HT3035	110 A	HT3110	250 A	JT3250
40 A	HT3040	125 A	HT3125	—	—
45 A	HT3045	150 A	HT3150	—	—
50 A	HT3050	—	—	—	—
60 A	HT3060	—	—	—	—



H-Frame

Trip Unit

PowerPact® H- and J-Frame Circuit Breakers

Section 1—General Information

UL 489 SC Listed 500 Vdc Circuit Breakers

The UL Listed thermal-magnetic molded case circuit breakers are specifically designed for use on ungrounded dc systems having a maximum short-circuit voltage of 500 Vdc or a maximum floating (unloaded) voltage of 600 Vdc. The circuit breakers are suitable for use only with UPS (uninterruptible power supplies) and ungrounded systems. This two-level voltage rating allows these circuit breakers to be applied to battery sources having a short-circuit availability of 20,000 amperes at 500 Vdc.

These circuit breakers are UL Listed for the interrupting ratings shown only if applied with three poles connected in series (series connection is external to circuit breaker). See diagram below.

NOTE: Due to external series connection, I-Line® circuit breakers are not available for this application.

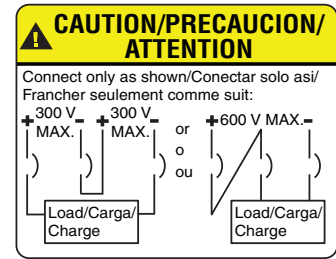

Source = 600 Vdc max. (floating)
 500 Vdc max. (loaded)

Table 23: DC Molded Case Circuit Breakers

Ampere Rating	Circuit Breaker Cat. No.	Adjustable Magnetic Trip Range—DC Amperes		Interrupting Rating @ 500 Vdc
		Low	High	
100 A	JGL37100D81	400	600	20 k AIR
125 A	JGL37125D81	400	600	
150 A	JGL37150D81	400	600	
175 A	JGL37175D81	400	600	
200 A	JGL37200D82	500	850	20 k AIR
225 A	JGL37225D82	500	850	
250 A	JGL37250D82	500	850	

Electronic Motor Circuit Protectors



PowerPact H- and J-frame Electronic Motor Circuit Protectors (MCP) are instantaneous-trip circuit breakers. They are designed to offer short circuit protection and are National Electrical Code® (NEC®) compliant when installed as part of a combination controller having motor overload protection. MCP circuit breakers accept the same accessories and terminals as the equivalent thermal-magnetic circuit breakers. (See Section 6, Figures 46 and 47 for trip curves. See Section 3 for Accessories.)

The unique design of the PowerPact MCPs include two dials to allow quick setting adjustments based on the characteristics of the motor.

The first dial allows for Full Load Amperes (FLA) adjustment across the range of the frame size.

The second dial selects the type of motor protection based on Automatic 1 for Standard Efficiency or Automatic 2 for High Energy Efficient. When using the automatic settings the MCP microprocessor automatically adjusts the trip settings for both current and time to align with the start-up characteristic for the motor type, whether it is a standard or energy-efficient motor. This includes a dampening means to accommodate a transient motor in-rush current without nuisance tripping of the circuit breaker. Dial 2 also allows for traditional motor protection from 8 to 13 times the selected FLA.

The MCP dials are detented and allow the device to be set to specific trip values within a typical accuracy range of +/-5%.

PowerPact® H- and J-Frame Circuit Breakers

Section 1—General Information

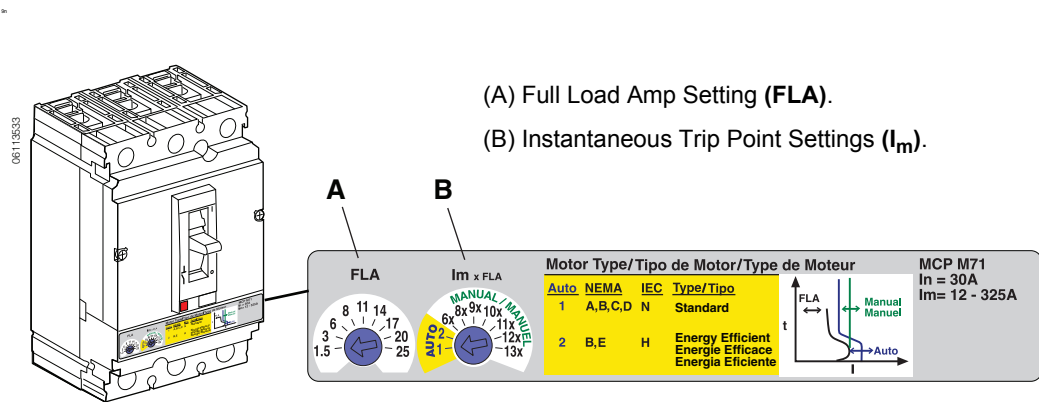

Full Load Amp Settings

1. Determine the motor's full-load current by referring to the nameplate on the motor.
2. Set the trip range by turning the FLA dial to the setting closest to the motor's full load current.

Automatic Protection Settings

The MCP microprocessor automatically adjusts the trip settings for both current and time to align with the start-up characteristics for the motor type selected. This includes a dampening means to accommodate a transient motor in-rush current without nuisance tripping of the circuit breaker.

Figure 5: Automatic Protection Settings

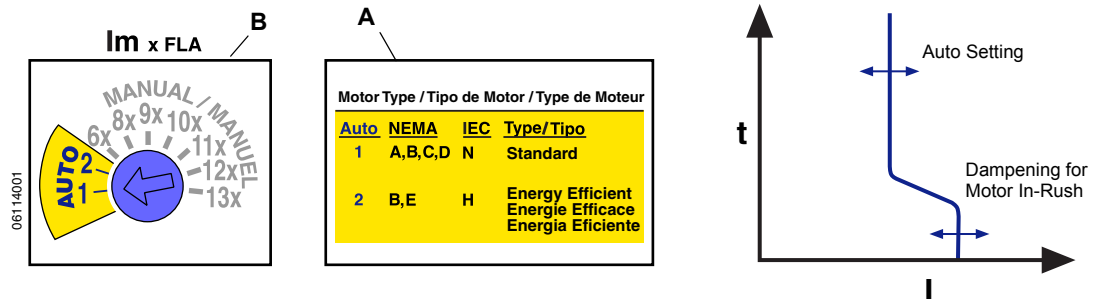

Manual Protection Settings

The manual settings may be adjusted to multiples of current based on the dial setting for motor Full Load Amps (FLA).

$$\text{Instantaneous Trip Point} = (\text{FLA}) \times (I_m)$$

PowerPact® H- and J-Frame Circuit Breakers

Section 1—General Information

For example, if FLA dial is set to 20 and I_m dial is set to 9x, then the instantaneous trip point will be 180 A.

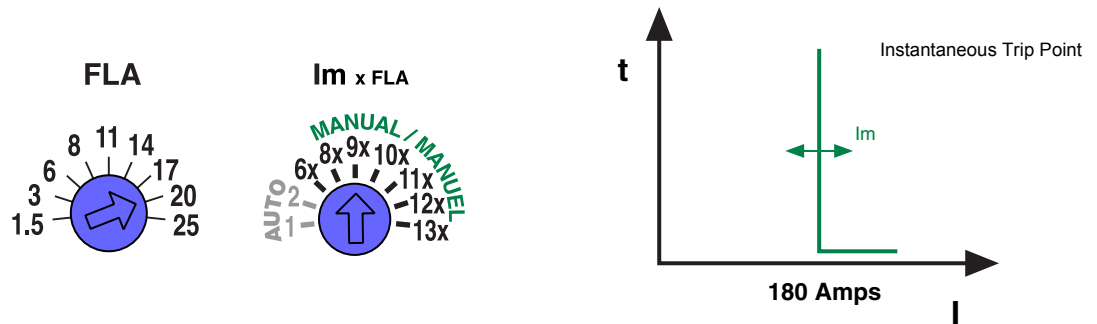

See Section 7 Tables 63 thru 67 for more information.

Table 24: H- and J-Frame Electronic Motor Circuit Protectors (MCP)

Frame	Current	Full Load Amperes Range	Adjustable Instantaneous Trip Range	Suffix	J Interrupting (See SCCR Table Below)	L Interrupting (See SCCR Table Below)
					Cat. No.	Cat. No.
H-Frame	30 A	1.5–25 A	9–325 A	M71	HJL36030M71	HLL36030M71
	50 A	14–42 A	84–546 A	M72	HJL36050M72	HLL36050M72
	100 A	30–80 A	180–1040 A	M73	HJL36100M73	HLL36100M73
	150 A	58–130 A	348–1690 A	M74	HJL36150M74	HLL36150M74
J-Frame	250 A	114–217 A	684–2500 A	M75	JJL36250M75	JLL36250M75

- High Short Circuit Current Ratings (SCCR)
The PowerPact MCP helps achieve the high UL508A Short Circuit Current Rating (SCCR) needed to meet NEC Article 409 requirements for industrial control panels. They deliver up to 100 kA at 480 Vac SCCR when used in combination with approved Square D® NEMA or Telemecanique® IEC motor starters.

Table 25: Short Circuit Current Ratings (SCCR)

Contactor/Starter	J Interrupting			L Interrupting		
	200–240 Vac	480 Vac	600 Vac	200–240 Vac	480 Vac	600 Vac
Tesys D-line and F-line	100 kA	65 kA	25 kA	100 kA	100 kA	50 kA
NEMA Type S	100 kA	65 kA	25 kA	100 kA	100 kA	50 kA

PowerPact® H- and J-Frame Circuit Breakers

Section 1—General Information

Table 26: MCP Selection by HP Ratings of Induction-Type Squirrel-Cage and Wound-Rotor Motors

Horsepower Rating of Induction-Type Squirrel-Cage and Wound-Rotor Motors 3Ø 60 Hz					NEC Full Load Amperes	PowerPact H-Frame and J-Frame Electronic MCP		
Starter Size	200 Vac	230 Vac	480 Vac	575 Vac				
00	1/2	1/2	1/2	1/2	0.9 A	HJL36030M71 and HLL36030M71 1/2–10 hp		
			3/4	3/4	1.1 A			
			1	1	1.3 A			
			1	1	1.7 A			
			1	1	2.1 A			
			1	1	2.2 A			
			1	1	2.4 A			
	3/4	3/4	3/4	1-1/2	1-1/2			2.5 A
				2	2			2.7 A
				2	2			3 A
				2	2			3.2 A
				2	2			3.4 A
				2	2			3.7 A
	1	1	1	3	3			3.9 A
				3	3			4.2 A
				3	3			4.8 A
				3	3			4.8 A
3				3	6 A			
1-1/2	1-1/2	1-1/2	5	5	6.1 A			
			5	5	6.8 A			
			5	5	6.9 A			
			5	5	7.6 A			
0	2	3	7-1/2	7-1/2	7.8 A			
			10	10	9 A			
1	5	5	10	10	9.6 A			
			10	10	11 A			
			10	10	14 A			
			10	10	15.2 A			
			10	10	17 A			
2	7-1/2	7-1/2	15	15	17.5 A			
			20	20	21 A			
			25	25	22 A			
3	10	10	25	25	25.3 A			
			30	30	27 A			
			30	30	28 A			
			30	30	32 A			
4	15	15	40	40	32.2 A			
			40	40	34 A			
			40	40	40 A			
			40	40	41 A			
			40	40	42 A			
5	20	20	50	50	48.3 A			
			50	50	52 A			
			50	50	54 A			
			50	50	62 A			
5	25	25	60	60	65 A			
			60	60	68 A			
			60	60	77 A			
5	30	30	75	75	78.2 A			
			75	75	80 A			
			75	75	92 A			
5	40	40	100	100	96 A			
			100	100	99 A			
			100	100	104 A			
5	50	50	125	125	120 A			
			125	125	124 A			
			125	125	125 A			
			125	125	130 A			
			125	125	144 A			
			125	125	150 A			
			125	125	154 A			
5	60	60	150	150	156 A			
			150	150	177.1 A			
			150	150	180 A			
			150	150	192 A			
			150	150	221 A			
5	75	75	200	200	240 A			
			200	200	248 A			
5	100	100	200	200	240 A			
			200	200	248 A			

Shaded area is not covered by J-frame electronic motor circuit protector.

PowerPact® H- and J-Frame Circuit Breakers

Section 1—General Information

Automatic Molded Case Switches

H-frame and J-frame circuit breakers are also available in automatic molded case switch construction. Automatic switches are similar in construction to circuit breakers, except that the switches open instantaneously at a factory-set non-adjustable trip point calibrated to protect only the molded case switch itself.

Because of their molded case construction, they are more compact than conventional disconnect switches and accept electrical accessories for added flexibility. Molded case switches are intended for use as disconnect devices only.

UL 489 requires molded case switches to be protected by a circuit breaker or fuse of equivalent rating. Molded case switches are labeled with their withstand ratings. The withstand rating of a switch is defined as the maximum current at rated voltage that the molded case switch will withstand without damage when protected by a circuit breaker or fuse with an equal or continuous current rating.

Table 27: Automatic Molded Case Switch Specifications

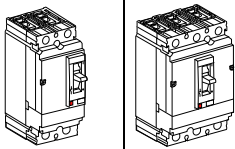
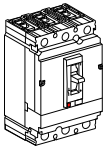
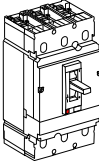
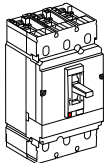
Frame		H-Frame				J-Frame				
Interrupting Performance		“G”		“L”		“G”		“L”		
										
UL 489	Poles	2P	3P	2P ¹	3P	2P ¹	3P	2P ¹	3P	
	Catalog Number	150 A	HGL26000S15	HGL3600S15	HLL26000S15	HLL36000S15	—	—	—	—
		175 A	—	—	—	—	JGL26000S17	JGL36000S17	JLL26000S17	JLL36000S17
		250 A	—	—	—	—	JGL26000S25	JGL36000S25	JLL26000S25	JLL36000S25
	Withstand Ratings	240 Vac	65 kA	65 kA	125 kA	125 kA	65 kA	65 kA	125 kA	125 kA
		480 Vac	35 kA	35 kA	100 kA	100 kA	35 kA	35 kA	100 kA	100 kA
600 Vac		18 kA	18 kA	50 kA	50 kA	18 kA	18 kA	50 kA	50 kA	
250 Vdc		20 kA	20 kA	20 kA	20 kA	20 kA	20 kA	20 kA	20 kA	
AC Trip Point		2250 A	2250 A	2250 A	2250 A	3125 A	3125 A	3125 A	3125 A	
IEC 60947-3	Rated Insulation Voltage		750 Vac	750 Vac	750 Vac	750 Vac	750 Vac	750 Vac	750 Vac	
	Rated Impulse Withstand Voltage		8 kV	8 kV	8 kV	8 kV	8 kV	8 kV	8 kV	
	Rated Operational Voltage	ac	525 Vac	525 Vac	525 Vac	525 Vac	525 Vac	525 Vac	525 Vac	525 Vac
dc		500 Vdc	500 Vdc	500 Vdc	500 Vdc	500 Vdc	500 Vdc	500 Vdc	500 Vdc	

¹ 2P devices use a 3P switch frame with the center pole inoperative.

Table 28: PowerPact H-Frame and J-Frame 250 A Unit-Mount Automatic Molded Case Switches, 600 Vac with Factory Sealed Trip Unit (Suitable for Reverse Connection)

Poles	Ampere Rating	G Interrupting		L Interrupting		Terminal	Wire Range
		Cat. No.	Trip Point	Cat. No.	Trip Point		
2	150 A	HGL26000S15 ¹	2250 A	HLL26000S15	2250A	AL150HD	14 AWG–3/0 AWG Al/Cu
	175 A	JGL26000S17	3125 A	JLL26000S17	3125 A	AL175JD	4–4/0 AWG Al/Cu
	250 A	JGL26000S25	3125 A	JLL26000S25	3125 A	AL250JD	3/0 AWG–350 kcmil Al/Cu
3	150 A	HGL36000S15	2250 A	HLL36000S15	2250 A	AL150HD	14 AWG–3/0 AWG Al/Cu
	175 A	JGL36000S17	3125A	JLL36000S17	3125 A	AL175JD	4–4/0 AWG Al/Cu
	250 A	JGL36000S25	3125A	JLL36000S25	3125 A	AL250JD	3/0 AWG–350 kcmil Al/Cu

¹ True 2P device. Others are a 2P in a 3P module.

PowerPact® H- and J-Frame Circuit Breakers Section 1—General Information

Table 29: PowerPact H-Frame and J-Frame I-Line Automatic Molded Case Switches, 600 Vac with Factory Sealed Trip Unit (Suitable for Reverse Connection)

Ampere Rating	2-pole	3-pole	Withstand Rating ¹			Trip Point	Terminal Wire Range
	Cat. No.	Cat. No.	240 Vac	480 Vac	600 Vac		
G Interrupting							
150 A	HGA26000S15() ²	HGA36000S15	65	35	18	1300 A	AL150HD #14–#3/0 AWG Al or Cu
175 A	JGA26000S17()	JGA36000S17	65	35	18	2500 A	AL250JD #3/0–350 kcmil Al or Cu
250 A	JGA26000S25()	JGA36000S25					
L Interrupting							
150 A	HLA26000S15()	HLA36000S15	125	100	50	1300 A	AL150HD #14–#3/0 AWG Al or Cu
175 A	HLA26000S17()	JLA36000S17	125	100	50	1300 A	AL250JD
250 A	JLA26000S25()	JLA36000S25				2500 A	#3/0–350 kcmil Al or Cu

¹ The withstand rating is the fault current, at rated voltage, that the molded case switch will withstand without damage when protected by a circuit breaker or fuse with an equal continuous current rating.

² 2-pole device with 3 in. (76 mm) mounting height, all other 2-pole circuit breakers use 3-pole module 4.5 in. (114 mm) mounting height.

Section 2—Mounting and Connections

Table 30: Circuit Breaker Mounting and Connections

Circuit Breaker Construction	Unit Mount ¹			I-Line®	Drawout
	Lug-Lug	Rear	Bus Bar		
H-Frame	X	X	X	X	X
J-Frame	X	X	X	X	X

¹ Including rail, backplate, and flush mounting

Unit-Mount Circuit Breakers

The standard lugs can be removed for the installation of compression-type lugs or bus connections. All lugs are UL Listed for their proper application and marked for use with aluminum and copper (Al/Cu) or copper only (Cu) conductors. Lugs suitable for copper and aluminum conductors are made of tin-plated aluminum.

Mounting

H- and J-frame circuit breakers may be mounted vertically, horizontally or flat on their back without any derating of characteristics.

Fixed-mounted H- and J-frame individually-mounted circuit breakers are supplied with two mounting screws. These mounting screws are inserted through mounting holes molded into the circuit breaker case and threaded into the mounting enclosure, rails or through the panel door for flush mounting.

A DIN rail mounting bracket (catalog no. S29305) is available for the H- and J-frame circuit breakers .

NOTE: DIN rail mounting is not compatible with motor operated applications.

Figure 6: Unit-Mounting Options

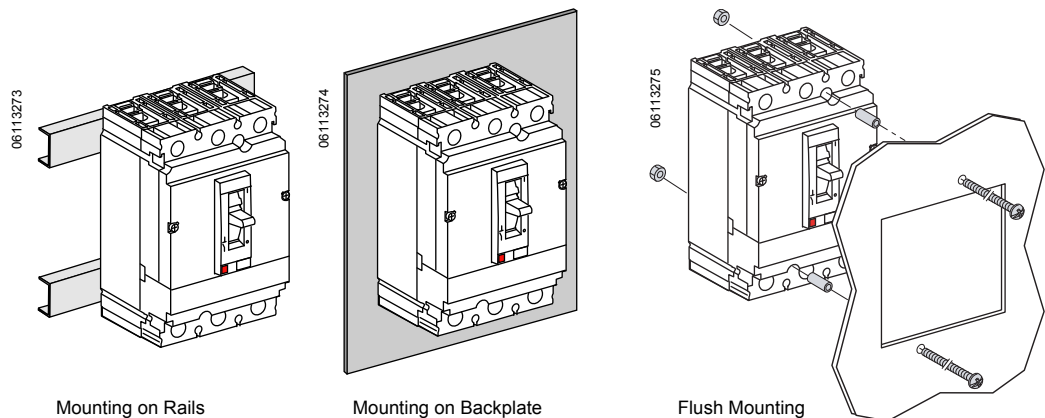

PowerPact® H- and J-Frame Circuit Breakers

Section 2—Mounting and Connections





Mechanical Lugs

Unit-mount H-frame and J-frame circuit breakers can be ordered with mechanical line and load side lugs. The standard lugs can be removed for the installation of compression-type lugs or bus connections. All lugs are UL Listed for their proper application and marked for use with aluminum and copper (Al/Cu) or copper only (Cu) conductors. Lugs suitable for copper and aluminum conductors are made of tin-plated aluminum. Lugs suitable for use with copper conductors only are made of copper.

Mechanical Lugs for the H- and J-frame circuit breakers lay on top of the circuit breaker terminals and can be installed without the use of any tools. The lugs are held in place with snap features built into the insulative retainer and are secured with the clamp force applied to the wire binding screw.

Mechanical lugs come in both aluminum and copper versions and are sold either factory installed or as field installable kits.

Table 31: Mechanical Lugs for H- and J-Frame Circuit Breakers

	Catalog Number	Frame	Ampere Range	Conductor	Wires Per Lug	Temp.	Strip Length	Wire Binding Screw Torque
06113289 	AL150HD	HD/HG/HJ/HL	15–150	Al/Cu	(1) 14–10 AWG (2.5–6 mm ²)	75°C	0.65 in. (16 mm)	50 lb-in (5 N•m)
					(1) 8–3/0 AWG (10–95 mm ²)	75°C	0.65 in. (16 mm)	120 lb-in (14 N•m)
06113290 	CU150HD	HD/HG/HJ/HL	15–150	Cu	(1) 14–2/0 AWG (2.5–70 mm ²)	75°C	0.65 in. (16 mm)	120 lb-in (14 N•m)
06113291 	AL175JD	JD/JG/JJ/JL	150–175	Al/Cu	(1) 4–4/0 AWG (20–95 mm ²)	75°C	1.0 in. (25 mm)	225 lb-in (26 N•m)
06113292 	AL250JD ¹	JD/JG/JJ/JL	200–250	Al/Cu	(1) #3/0–350 kcmil (120–185 mm ²)	75°C	1.0 in. (25 mm)	225 lb-in (26 N•m)
06113293 	CU250JD	JD/JG/JJ/JL	150–250	Cu	(1) 1/0 AWG–300 kcmil (50–185 mm ²)	75°C	1.0 in. (25 mm)	250 lb-in (28 N•m)

¹ AL250JD lugs are required for 250–350 kcmil wire range.

06113276

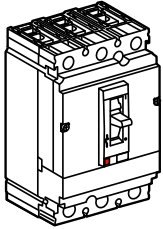

PowerPact® H- and J-Frame Circuit Breakers

Section 2—Mounting and Connections

Bus-Bar Connections

Both H-frame and J-frame circuit breakers may be equipped with captive nuts and screws for direct connection to bars.

Terminal nut inserts are needed for replacement of lug connections with bus bar connections.

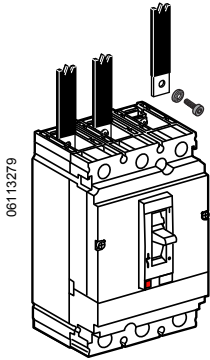
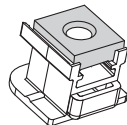

Table 32: Terminal Nuts for Bus Bar Connection of H-Frame and J-Frame Circuit Breakers

Description	Frame	Tap	Cat. No.	Qty Per Kit	Torque
H-Frame Terminal Nut Insert–English	HD/HG/HJ/HL	1/4-20	S37425	2	80–90 lb-in (9–10.2 N•m)
H-Frame Terminal Nut Insert–English	HD/HG/HJ/HL	1/4-20	S37444	3	
H-Frame Terminal Nut Insert–Metric	HD/HG/HJ/HL	M6	S37426	2	
J-Frame Terminal Nut Insert–English	JD/JG/JJ/JL	1/4-20	S37427	2	80–90 lb-in (9–10.2 N•m)
J-Frame Terminal Nut Insert–English	JD/JG/JJ/JL	1/4-20	S37445	3	
J-Frame Terminal Nut Insert–Metric	JD/JG/JJ/JL	M8	S37428	2	



Terminal Nut Insert

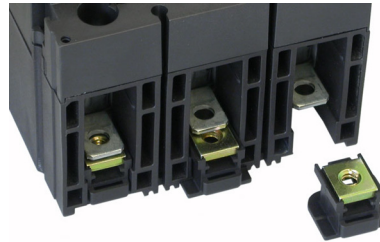
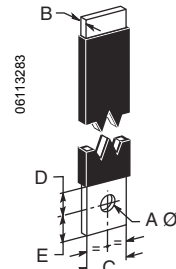

Table 33: Bar Dimensions

Dimension	H-Frame	J-Frame
A	0.250 in. (6.4 mm)	0.3125 in. (7.9 mm)
B	0.125–0.375 in. (3.2–9.5 mm)	0.125–0.375 in. (3.2–9.5 mm)
C	0.50 in. (12.7 mm)	0.50–0.75 in. (12.7–1.1 mm)
D	0.3 in. (7.6 mm)	0.625 in. (15.9 mm)
E	0.3 in. (7.6 mm)	0.375 in. (9.5 mm)



Voltage Takeoff (Control Wire Terminals) for Mechanical Lugs and Terminal Nuts

Mechanical lugs may be equipped with a separate control wire termination. The kit is available factory installed or as a field installable kit. The adaptor is secured underneath the lug and has a tab extension suitable for attachment of a .250 inch slip-on connector.

Fully insulated type connectors must be used to prevent live parts from extending into the wiring gutter area.

Table 34: Control Wire Terminals

Description	Frame	Cat. No.	Qty Per Kit
Mechanical Lugs			
Control Wire Terminal for H-Frame Lugs	HD/HG/HJ/HL	S37423	2
Control Wire Terminal for J-Frame Lugs	JD/JG/JJ/JL	S37424	2
Bussbar Connection			
Control Wire Terminal for H-Frame Terminal Nut	HD/HG/HJ/HL	S37429	2
Control Wire Terminal for J-Frame Terminal Nut	JD/JG/JJ/JL	S37430	2

Mechanical Lug Control Wire Terminal

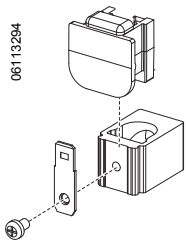

Bussbar Control Wire Terminal

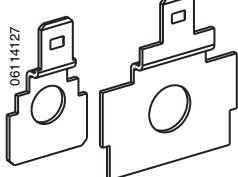

PowerPact® H- and J-Frame Circuit Breakers





Section 2—Mounting and Connections

Power Distribution Connectors

The power distribution connectors (PDC) can be used for multiple load wire connections on one circuit breaker. Use in place of standard distribution blocks to save space and time. Field installable kit includes tin-plated aluminum lug, connectors, and required mounting hardware.

- For use on load end of circuit breaker only
- For use in UL 508 Industrial Control applications only
- For use in UL 1995/CSA C22.2 No. 236 heating and cooling equipment
- For copper wire only

Table 35: Power Distribution Connectors

	Frame	Kit Number	Number of Wires	Wire Range	Wire Binding Screw Torque
06113296 	H-Frame	PDC6HD6	6	8–6 AWG (10–16 mm ²)	25 lb-in (2.8 N•m)
				14–10 AWG (2.5–6 mm ²)	20 lb-in (2.3 N•m)
06113297 	H-Frame	PDC3HD2	3	6–2 AWG (16–35 mm ²)	40 lb-in (4.5 N•m)
				14–8 AWG (2.5–10 mm ²)	35 lb-in (4.0 N•m)
06113298 	J-Frame	PDC6JD4	6	6–4 AWG (16–25 mm ²)	35 lb-in (4.0 N•m)
				8 AWG (10 mm ²)	25 lb-in (2.8 N•m)
				14–10 AWG (2.5–6 mm ²)	20 lb-in (2.3 N•m)
06113299 	J-Frame	PDC3JD20	2 and 1	14–6 AWG Cu (2.5–16 mm ²)	35 lb-in (4.0 N•m)
				3–2/0 AWG Cu (35–70 mm ²)	50 lb-in (5.6 N•m)
			2 and 1	4–1 AWG Cu (25–70 mm ²)	40 lb-in (4.5 N•m)
				3–2/0 AWG Cu (35–70 mm ²)	50 lb-in (5.6 N•m)

See Table 37 for the phase barriers for PDCs.

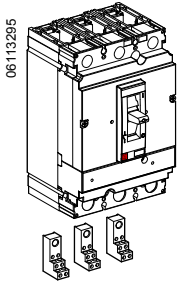

PowerPact® H- and J-Frame Circuit Breakers

Section 2—Mounting and Connections

Compression Lugs

Both copper and aluminum compression lug kits are available for the H-frame and J-frame circuit breakers. Each kit contains required insulators and all mounting hardware.

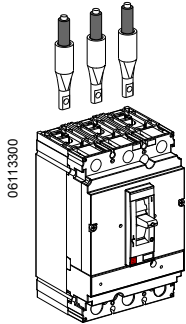

Table 36: Compression Lug Kits

Lug Type		Frame	Kit Number	Wire Range	Ampere Rating	Lugs Per Kit	Mounting Screw Torque
Aluminum	06113301	H-Frame	YA060HD	6–2 AWG Cu or Al (16–35 mm ²)	≤ 60 A	3	80–90 lb-in (9.0–10.2 N•m)
			YA150HD	1/0–4/0 AWG Cu or Al (50–95 mm ²)	≤ 150 A	3	80–90 lb-in (9.0–10.2 N•m)
	06113302	J-Frame	YA150JD	1–3/0 AWG Cu or Al (50–95 mm ²)	≤ 200 A	3	130–140 lb-in (14.7–15.8 N•m)
			YA250J35	3/0 AWG–350 kcmil Cu or Al (95–185 mm ²)	≤ 250 A	3	130–140 lb-in (14.7–15.8 N•m)
Copper	06113303	H-Frame	CYA060HD	6–1/0 AWG Cu (16–50 mm ²)	≤ 60 A	3	80–90 lb-in (9.0–10.2 N•m)
			CYA150HD	4–2/0 AWG Cu (25–70 mm ²)	≤ 150 A	3	80–90 lb-in (9.0–10.2 N•m)
	06113304	J-Frame	CYA150JD	4–2/0 AWG Cu (25–70 mm ²)	≤ 150 A	3	130–140 lb-in (14.7–15.8 N•m)
			CYA250J3	2/0 AWG–300 kcmil Cu (70–185 mm ²)	≤ 250 A	3	130–140 lb-in (14.7–15.8 N•m)

Terminal Shields

Table 37: Terminal Shields and Phase Barriers

Used With	Description		Cat. No.	Qty Per Kit	Dimension B (in.)			
Mechanical Lugs	Short Lug Shield ¹	Frame	Max. Wire Size					
		H-Frame 60 A	3 AWG	S37446	1		0.50	
		H-Frame 150 A	3/0 AWG	S37447	1		0.50	
		J-Frame	350 kcmil	S37448	1		0.24	
Power Distribution Connectors and Compression Lugs	Compatible with:	PDC						
		Compression Lugs						
	H-Frame Long Lug Shield	PDC6HD6	YA060HD	CYA060HD	S37449 ²		1	2.24
		PDC3HD2	YA150HD	CYA150HD				
	J-Frame Long Lug Shield	PDC6JD4	YA150JD	CYA150JD	S37450 ²		1	1.68
		PDC3JD2		CYA250J3				
Phase Barriers				29329	6	3.13		

¹ Short lug shields provide IP20 protection for mechanical lugs and are compatible with control wire terminals.

² J-frame terminal shield is not compatible with the YA250J35 compression terminal.

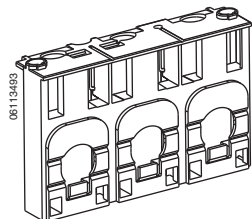

H-Frame Short Lug Shield

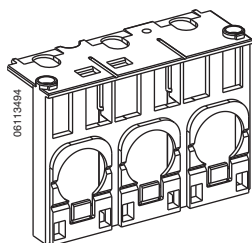

J-Frame Short Lug Shield

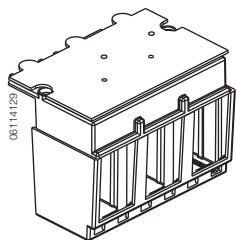

J-Frame Long Lug Shield

Rear Connections

Rear connections are easily installed on the circuit breaker terminals. The same connection may be installed flat, vertical or at a 45° angle with all combinations possible. The circuit breaker is mounted on a backplate.

Figure 7: Four Positions Possible for Each Connector

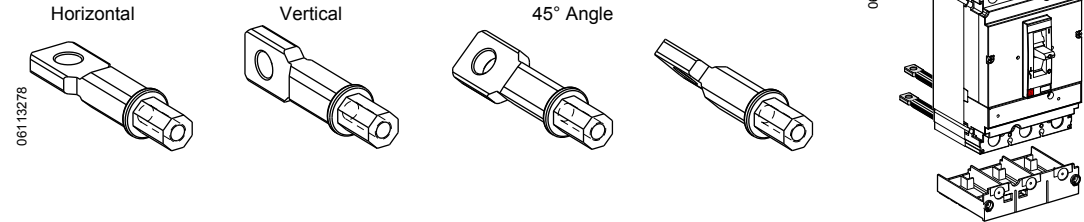

Table 38: Rear Connections

Device	Description	Poles	H-Frame		J-Frame	
			Factory-Installed Termination No.	Field-Installable Catalog Number	Factory-Installed Termination No.	Field-Installable Catalog Number
Mixed Rear Connection Kit		2 3	S S	— S37432	S S	— S37437
Consisting of:	Short Rear Connections (Set of 2)	2 or 3	—	2x S37433 ¹	—	2x S37438 ¹
	Long Rear Connections (Set of 2)	2 or 3	—	S37434	—	S37439
	Short Terminal Cover (3P)	3	—	S37436	—	S37440

¹ For use with 3P circuit breakers only.

I-Line® Circuit breakers

H- and J-frame circuit breakers are available in I-Line construction for easy installation and removal in I-Line panelboards and switchboards.

I-Line circuit breakers use “blow-on” type line side connectors. In case of a short circuit, increased magnetic flux causes the plug-on connectors of the circuit breaker to tighten their grasp on the panelboard or switchboard bus bars. The I-Line connectors and circuit breaker mounting bracket are integral parts of I-Line circuit breakers and cannot be removed or replaced. I-Line circuit breakers come with mechanical load side lugs.

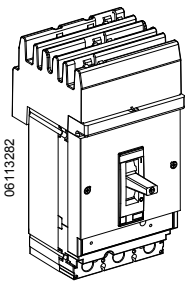

Table 39: Phase Options—Example HDA36150()

Phase Option Number	Phase Connection	2P Example	3P Example
1	AB	HDA261501	—
2	AC	HDA261502	—
3	BA	HDA261503	—
4	BC	HDA261504	—
5	CA	HDA261505	—
6	CB	HDA261506	—
Standard	ABC	—	HDA36150
6	CBA	—	HDA361506

PowerPact® H- and J-Frame Circuit Breakers

Section 2—Mounting and Connections

Plug-In and Drawout Circuit Breakers

H- and J-frame circuit breakers are available in a plug-in and drawout construction.

Plug-In Circuit Breaker Mounting

The plug-in base is mounted through a front panel. The plug-in configuration makes it possible to:

- Extract and/or rapidly replace the circuit breaker without having to touch connections
- Allow for addition of future circuits at a later date

When the circuit breaker is in the connected position, the primary voltage is fed through the circuit breaker by means of multiple finger disconnects. Control voltage of internal accessories is provided through secondary disconnects.

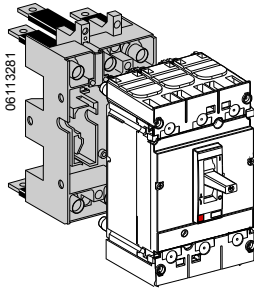

Plug-In Mounting

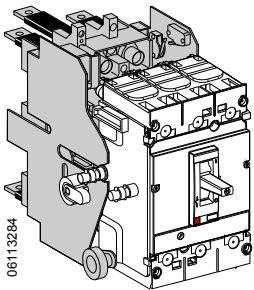

Drawout Mounting

Parts of a Plug-In Configuration

- Disconnects: Provides both primary and secondary disconnect to the circuit breaker.
- Safety Trip Interlock: The safety trip causes automatic tripping if the circuit breaker is ON before engaging or withdrawing it; the safety trip does not prevent the circuit breaker operation, even when the circuit breaker is disconnected.
- Plug-in Base: The plug-in base provides mounting through a front panel or mounting on rails.

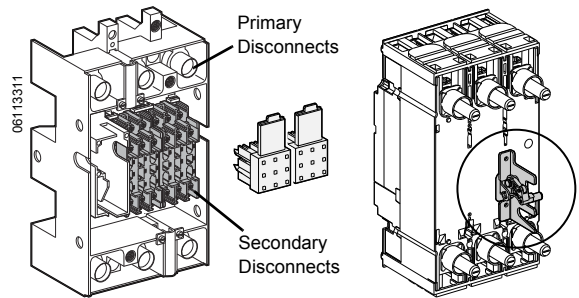

Safety Trip Interlock Mounted on Back of Circuit Breaker

Figure 8: Plug-In Base (Mounting Options)

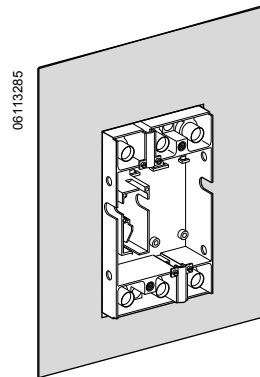

Mounting Through a Front Panel

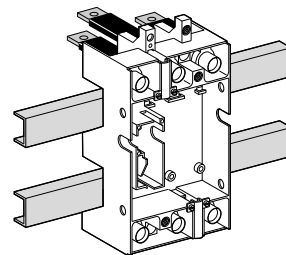

Mounting on Rails

Table 40: Plug-In Mounting

Description	Suffix	Catalog No.
Kit for Compact NSF Circuit Breaker (Stationary and Moving Part)	N	29293
Stationary Part	—	—
Plug-In Base	—	29278
Moving Part	HJ00	—
Consisting of:		
Short Terminal Covers	—	29321
Safety Trip Interlock	—	29270
Power Connections	—	29268 (3)

Drawout Circuit Breaker Mounting

The drawout-mounted chassis is Listed under UL file E113555 and Certified under CSA file LR69561. The chassis is made up of two side plates installed on the base and two other plates mounted on the circuit breaker.

Figure 9: Drawout Mounting Positions

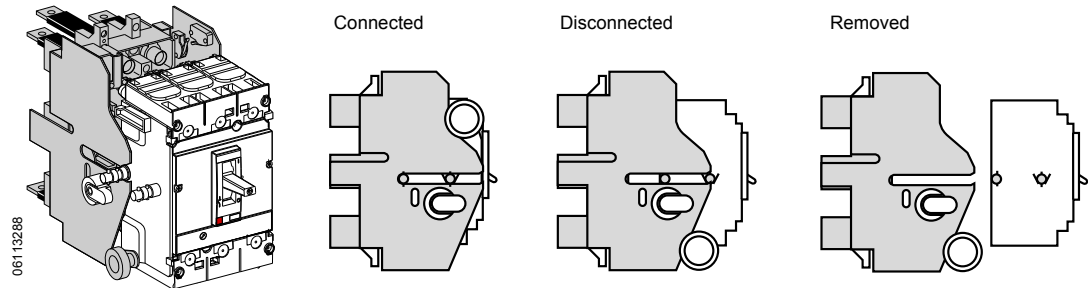

Table 41: Drawout Mounting

Description	Suffix	Catalog No.
Kit for Compact NSF Circuit Breaker (Stationary and Moving Part)	N	29293
Stationary Part	—	—
Plug-In Base	—	29278
Fixed Part of Chassis	—	29282
Moving Part	HJ00	—
Consisting of:		
Moving Part of Chassis	—	29282
Short Terminal Covers	—	29321
Safety Trip Interlock	—	29270
Power Connections	—	29268 (3)

Table 42: Plug-In and Drawout Accessories

Description	Catalog No.
Secondary Disconnecting Blocks	
Fixed Part 9-Wire Connector	29273
Moving Part 9-Wire Connector	29274
Support for 2 Moving Connectors	29275
Shutters	
Two Shutters for Plug-In Base	29271
Chassis Accessories	
Extended Escutcheon for Toggle (For circuit breakers with toggle through front panel, intended to maintain the degree of protection whatever the position of the circuit breaker. Supplied with a toggle extension.)	29284
Locking Device (Key Lock is Not Included)	29286
Two Position Indicating Switches (Connected/Disconnected) (Circuit breaker position switches may be applied on the fixed part of the chassis, indicating the “connected” and “disconnected” positions.)	29287

Toggle Collar

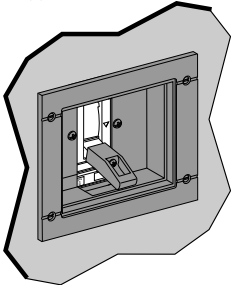

Chassis Functions

All functions of the plug-in base, plus:

- Disconnected position: the power circuit is disconnected, the circuit breaker is simply “withdrawn” and may still be operated (ON (I), OFF (O), push-to-trip)
- Circuit breaker may be locked using one to three padlocks—padlock diameters 0.19–0.31 in. (5–8 mm)

Section 3—Accessories

Internal Accessories

Field-installable accessories provide flexibility for installation at point of use.

Auxiliary switches and the shunt trip or undervoltage release are easy to install, reliable and common to many PowerPact® circuit breakers.

Figure 10: Accessory Locations

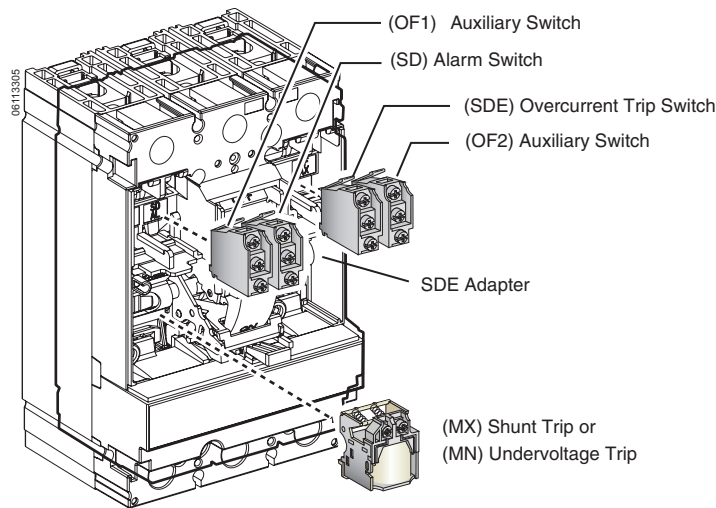

Table 43: Maximum Accessory Combinations

Poles	Device	Combination
2P (HD + HG) ¹	Shunt trip or UVR (Undervoltage Release)	1A/1B + Alarm (SD)
3P	Shunt trip or UVR (Undervoltage Release)	2A/2B + Alarm (SD) + Overcurrent Trip (SDE)

¹ All other 2P devices are 2P in a 3P module

Accessory Connections

Electrical accessories are fitted with numbered terminal blocks for wires with the following maximum size:

- 16 AWG (1.5 mm²) for auxiliary switches (OF1 or OF2), and shunt trip (MX) or undervoltage trip (MN)
- 14 AWG (2.5 mm²) for the motor operator

Auxiliary circuit wiring exits fixed mounted devices through a knock-out in the front cover.

Figure 11: Accessory Connections

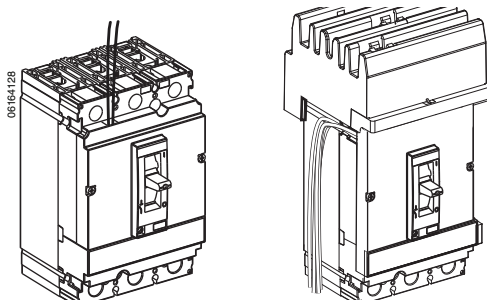

NOTE: See page 32 for plug-in and drawout options.

Auxiliary and Alarm Switches

Auxiliary switches provide remote information of the circuit breaker status and can thus be used for indications, electrical locking, relays, etc.



OF/SD Switch

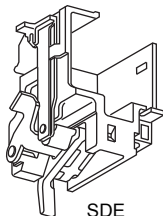

SDE

Applications	Open/Closed (OF) Auxiliary Switch
	<ul style="list-style-type: none"> Indicates the position of the circuit breaker contacts
	Trip Indication (SD) Switch
Installation & Connection	<ul style="list-style-type: none"> Bell alarm indicates that the circuit breaker has tripped due to an overload, short circuit or ground fault, the operation of a shunt trip or undervoltage trip or the "push-to-trip" button Resets when the circuit breaker is reset
	Overcurrent Trip Switch (SDE)
	<ul style="list-style-type: none"> Indicates that the circuit breaker has tripped due to an overload, short circuit or ground fault Resets when the circuit breaker is reset <p>The above auxiliary switches are also available in low-level versions capable of switching very low loads (e.g., for controlling PLCs or electronic circuits).</p>
Standards	<ul style="list-style-type: none"> The OF, SD and SDE switches snap into cavities behind the front accessory cover of the circuit breaker One model serves for all indication functions depending on where it is fitted in the circuit breaker The SDE function of a circuit breaker equipped with a thermal-magnetic trip unit requires the SDE adapter The internal accessories comply with requirements of Underwriters Laboratories® Inc. (UL®) UL 489 and Canadian Standard Association C22.2 No. 5-02 Standards All internal accessories are Listed for fixed installation per UL file E103955 and Certified under CSA file LR 69561 Auxiliary switches comply with UL 489, CSA C22.2 No. 5-02 and IEC 60947-5 Standards "Low-level" switches are not UL Recognized

Table 44: Electrical Characteristics

Characteristic	Voltage	Standard (Silver Contacts)	Low-Level (Gold Contacts)	
Supplied as Standard (Form C)		4	4	
Maximum Number of Contacts		4	4	
Breaking Capacity at a Power Factor (p.f.) of 0.3	Standard (100 mA/24 V minimum load)			
	Vac	240/380	6 A	5 A
		480	6 A	5 A
		600/690	6 A	—
	Vdc	24/48	2.5 A	2.5 A
		240	0.5 A	0.8 A
		380	0.3 A	0.3 A
	Low-level (1 mA/4 V minimum load with a maximum current and voltage of 100 mA 10 V.			
	NOTE: NOTE: If the maximum voltage and current is exceeded, the low-level function of the switch will be lost but the switch will continue to function as a standard switch with the following specifications.			
	Vac	24/48	5 A	—
		240	5 A	—
		380	5 A	—
	Vdc	24/48	5/2.5 A	—
125		0.5 A	—	
250		0.3 A	—	

Table 45: Switch Catalog Numbers

Alarm/Overcurrent Trip Switch		
Switch	Factory-Installed Suffix	Field-Installable Kit No.
Alarm Switch (SD)	BC	S29450
Alarm Switch (SD) Low-level	BH	S29452
SDE Standard ¹	BD	S29450 + S29451
SDE Low-level ¹	BJ	S29452 + S29451
SD and SDE Standard ¹	BE	S29450 (2) + S29451
SD and SDE Low-level ¹	BK	S29452 (2) + S29451

¹ Includes SDE Adapter S29451.

Auxiliary Switch		
Contacts	Factory-Installed Suffix	Field-Installable Kit No.
1A/1B Standard	AA	S29450
2A/2B Standard	AB	S29450 (2)
1A/1B Gold	AE	S29482
2A/2B Gold	AF	S29482 (2)

Shunt Trip (MX) and Undervoltage Trip (MN) Switches

A voltage release can be used to trip the circuit breaker via a control signal.



Applications	Shunt trip (MX)
	<ul style="list-style-type: none"> Trips the circuit breaker when the control voltage rises above 70% of its rated voltage Impulse type ≥ 20 ms or maintained control signals AC shunt trips are suitable for ground fault protection when combined with a Class I ground fault sensing element
Installation and Connection	Undervoltage trip (MN)
	<ul style="list-style-type: none"> Trips the circuit breaker when the control voltage drops below a tripping threshold Drops out between 35% and 70% of the rated voltage Circuit breaker closing is possible only if the voltage exceeds 85% of the rated voltage Permanent type If an undervoltage condition exists, operation of the closing mechanism of the circuit breaker will not permit the main contacts to touch, even momentarily. This is commonly called "Kiss Free"
Operation	<ul style="list-style-type: none"> Accessories are common to H- and J-frame circuit breakers and snap into cavities under the front accessory cover of the circuit breaker Each terminal may be connected by one #18–#14 AWG (1.0–2.5 mm²) stranded copper wire The circuit breaker must be reset locally after being tripped by shunt trip or undervoltage trip (MN or MX) MN or MX tripping has priority over manual (or motor operator) closing; in the presence of a standing trip order such an action does not result in any closing, even temporarily, of the main contacts Endurance: 50% of the rated mechanical endurance of the circuit breaker for circuit breakers

Table 46: Electrical Characteristics

Description	AC	DC
Rated Voltage (V)	24, 48, 110, 130, 208, 277, 380, 480, 525, 600	12, 24, 30, 48, 60, 125, 250
Consumption	Pickup (MX)	< 10 VA
	Seal-in (MN)	< 5 VA
Clearing Time (ms)	< 50	< 50

Table 47: Shunt Trip and Undervoltage Trip Suffix Codes and Kit Numbers

Voltage	Shunt Trip		Undervoltage Release UVR	
	Factory-Installed Suffix	Field-Installable Kit No.	Factory-Installed Suffix	Field-Installable Kit No.
24 Vac	SK	S29384	UK	S29404
48 Vac	SL	S29385	UL	S29405
120 Vac	SA	S29386	UA	S29406
208-277 Vac	SD	S29387	UD	S29407
380-480 Vac	SH	S29388	UH	S29408
525-600 Vac	SJ	S29389	UJ	S29409
12 Vdc	SN	S29382	UN	S29402
24 Vdc	SO	S29390	UO	S29410
30 Vdc	SU	S29391	UU	S29411
48 Vdc	SP	S29392	UP	S29412
60 Vdc	SV	S29383	UV	S29403
125 Vdc	SR	S29393	UR	S29413
250 Vdc	SS	S29394	US	S29414

Add-On Ground-Fault Module (GFM)

The Micrologic® Ground-Fault Module (GFM) is a UL Listed circuit breaker accessory which protects equipment from damage caused by ground faults. It is an add-on module which, when connected to a PowerPact H- or J-frame circuit breaker, provides ground-fault sensing and ground-fault relay functions.

HD/JD ground-fault modules feature:

- Adjustable ground-fault pickup levels.
- Adjustable ground-fault time delays.
- Integral ground-fault push-to-test feature.
- Ground-fault indicator (mechanical for local, contacts for remote).
- All GFMs are supplied for I-Line® mounting as standard, easily convertible to unit mount by removing the I-Line bracket.
- Fault-powered (via the sensing current transformer) for electronics, shunt trip, and integral test feature. Meets NEC 230-95(c).
- A 12 Vdc shunt trip module (Catalog No. S29382) is required in the circuit breaker. This may be field installed or factory installed when the circuit breaker is ordered with an -SN suffix.

The GFM system requires the following:

- H-frame (15–150 A) or J-frame (150–250 A) molded case circuit breaker.
- Shunt trip for circuit breaker (may be factory-installed or field-installed).
- Bus bar connection (terminal nut inserts) for OFF end of circuit breaker.
- Optional neutral current transformer, catalog number GFM25CT (must be ordered for 4-wire applications).

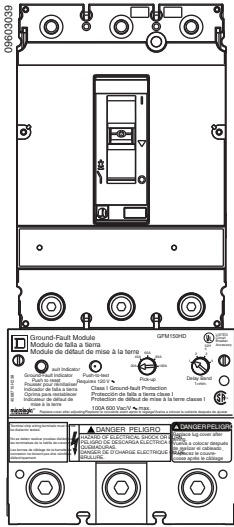

J-Frame Circuit Breaker
with GFM Installed

Table 48: Ground-Fault Module

Catalog No.	Rating	Sensitivity	Time Delay (Approximate)
GFM150HD	150 A	20, 40, 60, 80, 100 A	0.2, 0.3, 0.4, 0.6 sec
GFM250JD	250 A	40, 80, 120, 160, 200 A	0.2, 0.3, 0.4, 0.6 sec

See Section 6, Figure 48–49 for GFM trip curves.

Earth Leakage Module (ELM) for PowerPact H- and J-Frame MCCBs

The Earth Leakage Module (ELM) is an add-on module which, when connected to a PowerPact H- or J-frame MCCB, provides low-level ground-fault sensing and ground-fault relay functions.

Because these ELMs are highly sensitive (30 mA to 3 A), they provide much greater protection than GFMs (20 Amps to 200 Amps sensitivity). The ELMs provide greater protection of control circuits and other sensitive equipment. The associated circuit breaker must have a 48 Vdc shunt trip, which may be field-installed (kit S29392) or factory-installed (suffix –SP) in the H- or J-Frame circuit breaker.

The add-on Earth Leakage Module (ELM) features:

- Adjustable ground-fault pickup levels as low as 30 mA
- Adjustable ground-fault time delays from instantaneous to 500 msec (time delay can be applied to any setting)
- Integral ground fault push-to-test feature
- Ground-fault indicator; pop-up button for local status and contacts for remote indication (to be used only with the tripping option)
- All ELMs are supplied for I-Line® mounting and are easily convertible to unit-mount by removing the I-Line mounting feet
- Three poles; 240 to 600 Vac maximum: 3-phase, 3-wire (no neutral) and 1-phase, 2-wire applications
- Line-power obtained through internal bus to provide power for electronics, shunt trip, and integral test feature.
- A shunt trip is required in the circuit breaker; it may be field-installed or factory-installed in the PowerPact H and J circuit breakers.
- UL 1053 – Ground-fault Sensing and Relaying Equipment



J-Frame Circuit Breaker with ELM Installed

Table 49: ELM Selection Chart ¹

Companion Circuit Breaker		Enclosure Space Required I-Line Switchboard	Catalog Number	Pick-Up Adjustments	Ground-Fault Time Delay Adjustments
Prefix	Size				
HD, HG, HJ, HL	15–150 A	LA	ELM150HD	30 mA 100 mA 300 mA	Instantaneous 60 ms 100 ms 500 msec
JD, JG, JJ, JL	150–250 A	LA	ELM250JD	1A 3A	

¹ At 250 A, the ELM250JD can be used with 80% rated circuit breakers only.

See Section 6, Figure 50 for ELM Trip Curves.

Motor Operator

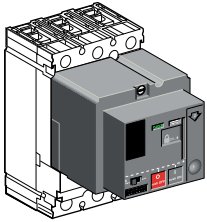

The motor operator remotely operates the circuit breaker featuring easy and sure operation:

- All circuit breaker indications and information remain visible and accessible, including trip unit settings and circuit breaker connection
- Suitability for isolation is maintained and padlocking remains possible
- Double insulation front face

Applications	<ul style="list-style-type: none"> • Local motor-driven operation, centralized operation, automatic distribution control • Normal/standby source changeover or switching to a replacement source to optimize energy costs • Load shedding and reconnection to optimize energy costs • Synchrocoupling—less than five cycle closing time
Installation and Connection	<ul style="list-style-type: none"> • All installation (fixed, plug-in/drawout mounting) and connection capabilities are maintained • Connections of the motor operator module are to a built-in terminal block behind its front cover • Stranded copper wire 14 AWG (2.5 mm²)
Automatic Operation	<p>The motor operator is connected in series with the overcurrent (SDE) trip switch. (The SDE adapter is included with the motor operator.) See wiring diagrams on page 44.</p> <ul style="list-style-type: none"> • ON (I) and OFF (O) by two impulse type or continuous control signals • Depending on the wiring, resetting can be done locally, remotely or automatically • Optional manual reset if tripping due to an electrical fault (with SDE) • Anti-pumping feature.
Manual Operation	<ul style="list-style-type: none"> • Transfer to manual mode with possibility of remote mode indication • ON (I) and OFF (O) by two push buttons • Recharging of stored-energy system by pumping the lever nine times • Padlocking in off position

Table 50: Motor Operator Characteristics

Response Time (ms)	Opening	< 500
	Closing	< 80
Maximum Cycles Per Minute		4
Control Voltage	AC 50/60 Hz	48–60
		110–130
		208–277
		380–480
		24–30
DC	48–60	
	110–130	
	250	
	250	
Consumption	AC (VA) Opening/Closing	500
	DC (W) Opening/Closing	500
Minimum Operating Order (ms)		700
Operating Voltage		85–110% rated

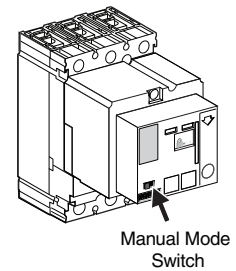

Table 51: Motor Operator Accessory Suffix Codes and Catalog Numbers

Voltage	Factory-Installed Suffix	Field-Installable Catalog No.	
		H-Frame	J-Frame
48/60 Vac	ML	S29440	S31548
120 Vac	MA	S29433	S31540
277 Vac	MD	S29434	S31541
380/480 Vac	MH	S29435	S31542
24/30 Vdc	MO	S29436	S31543
48/60 Vdc	MP	S29437	S31544
110/130 Vdc	MR	S29438	S31545
250 Vdc	MS	S29439	S31546

PowerPact® H- and J-Frame Circuit Breakers

Section 3—Accessories

Rotary Operating Handles

Directly-Mounted Rotary Operating Handles

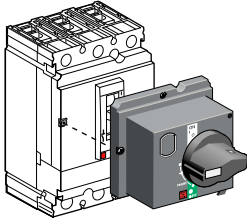

Directly Mounted Rotary Operating Handle

Installation	The directly mounted rotary operating handle replaces the circuit breaker front accessory cover (secured by screws).
Operation	<p>The direct rotary handle maintains:</p> <ul style="list-style-type: none"> • Suitability for isolation • Indication of three positions: ON (I), Tripped and OFF (O) • Access to the "push-to-trip" button • Visibility of, and access to, trip unit settings • The circuit breaker may be locked in the OFF position by using one to three padlocks (not supplied), padlock shackle diameter 0.19–0.31 in. (5–8 mm)
Models	<ul style="list-style-type: none"> • Standard with black handle • VDE type with red handle and yellow bezel for machine tool control
Variations	<p>Accessories transform the standard direct rotary handle for the following situations:</p> <ul style="list-style-type: none"> • Motor control centers (MCCs): <ul style="list-style-type: none"> – Opening of door prevented when circuit breaker is on – Closing of circuit breaker inhibited when door is open • Machine tool control; complies with CNOMO E03.81.501N; degree of protection IP54 • Early make or early break contacts may be installed into direct mount rotary handle
Standards	The directly-mounted rotary operating handle is UL Listed under file E103955 and CSA Certified under file LR 69561

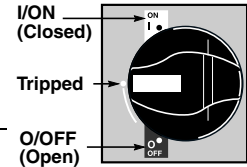

IEC-Style Door-Mounted Rotary Operating Handle

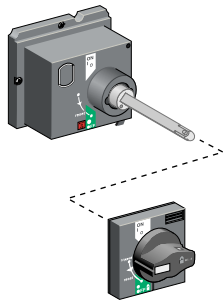

Door Mounted Rotary Operating Handle

Installation	<p>The extended rotary operating handle is made up of:</p> <ul style="list-style-type: none"> • A unit that replaces the front accessory cover of the circuit breaker (secured by screws) • An assembly (handle and front plate) on the door that is always secured in the same position, whether the circuit breaker is installed vertically or horizontally • An adjustable extension shaft • The handle mechanism can be used in NEMA 3R and 12 enclosure applications
Operation	<p>The door mounted operating handle makes it possible to operate circuit breakers installed in enclosure from the front. The door mounted operating handle maintains:</p> <ul style="list-style-type: none"> • Suitability for isolation • Indication of the three positions OFF (O), ON (I) and tripped • Visibility of and access to trip unit settings when the door is open • Degree of protection: IP40 as per IEC 529 <p>Defeatable interlock prevents opening of door when circuit breaker is on</p> <p>The circuit breaker may be locked in the off position by using one to three padlocks, padlock shackle diameter 0.19–0.31 in. (5–8 mm); padlocks are not supplied; locking prevents opening of the switchboard door</p>
Shaft Length	<p>The shaft length is the distance between the back of the circuit breaker and the door:</p> <ul style="list-style-type: none"> • Minimum shaft length is 7.4 (185 mm) • Maximum shaft length is 24 in. (600 mm) • Extended shaft length must be adjusted
Models	<ul style="list-style-type: none"> • Standard with black handle • VDE type with red handle and yellow bezel for machine tool control
Variations	For withdrawable configurations, the extended rotary handle is also available with a telescopic shaft containing two stable positions
Standards	The extended rotary operating handle is UL Listed under file E103955 and CSA Certified under file LR 69561

Table 52: Rotary Operating Handle Suffix Codes and Kit Numbers

Handle Type (color)	Factory-Installed Suffix	Field-Installable Kit No.
Direct Mount (black)	RD10	S29337
Extended Door Mount (black)	RE10	S29338
Telescoping (black)	RT10	S29343
Direct Mount (red)	RD20	S29339
Extended Door Mount (red)	RE20	S29340

Class 9421 NEMA Door Mounted Rotary Operating Handles



Installation	The extended rotary operating handle is made up of: <ul style="list-style-type: none"> • A mounting plate that provides a rotary actuator for a standard toggle circuit breaker • Handle assemblies available for NEMA 3, 3R, 4, and 4X • Available in standard or short (3 in.) handle assemblies
Operation	The door mounted operating handle makes it possible to operate circuit breakers installed in enclosure from the front. Provides ON (I) and OFF (O) indication The circuit breaker may be locked in the off position
Shaft Length	The shaft length is the distance between the back of the circuit breaker and the door: <ul style="list-style-type: none"> • Minimum mounting depth is 5.5 in. (138 mm) • Maximum mounting depth is 10.75 in. (273 mm) with standard shaft • Maximum mounting depth is 21.3 in. (543 mm) with long shaft

Table 53: Class 9421 Door-Mounted Operating Mechanism

Description	Catalog Number
Standard Shaft Kit	9421LJ1
Long Shaft Kit	9421LJ4

Table 54: Component Parts

Description		Catalog Number
Standard Handle Assembly	Type 1, 3R, 12	9421LH6
	NEMA Type 3 and 4, Painted	9421LH48
	NEMA Type 3 and 4, Chrome Plated	9421LC48
Operating Mechanism	Includes Lockout	9421LJ7
Standard Shaft	Support Bracket Not Required	9421LS8
Long Shaft	Support Bracket Included	9421LS10

Class 9422 Cable Operating Handle

Flange-mounted handle cable operating mechanism is for use with Class 9422 Type A handle operators especially designed for tall, deep enclosures where placement flexibility is required.

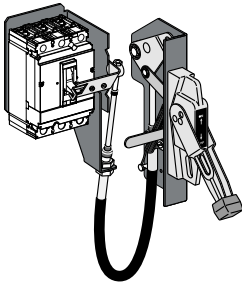

Applications	<ul style="list-style-type: none"> • The cable operator maintains: Suitability for isolation • Indication of three positions: O (OFF), I (ON) and tripped • Access to push-to-test • The circuit breaker may be locked in the off position by one to three padlocks • Door can be locked closed due to interlocking features of the handle operator
Installation	<ul style="list-style-type: none"> • Handle is mounted on flange of enclosure using specified mounting dimensions while circuit breaker and operating mechanism are mounted to inside of enclosure using two screws • Cable lengths available in 3-, 5- or 10-foot lengths to accommodate a variety of mounting locations • Handles are available in painted Nema 1, 3, 3R, 4 (sheet steel) and 12 ratings or chrome (Nema 4, 4x)

Table 55: Class 9422 Cable Mechanisms

Cable Mechanism Length	Catalog Number
36 in.	9422CSF30
60 in.	9422CSF50
84 in.	9422CSF70
120 in.	9422CSF10

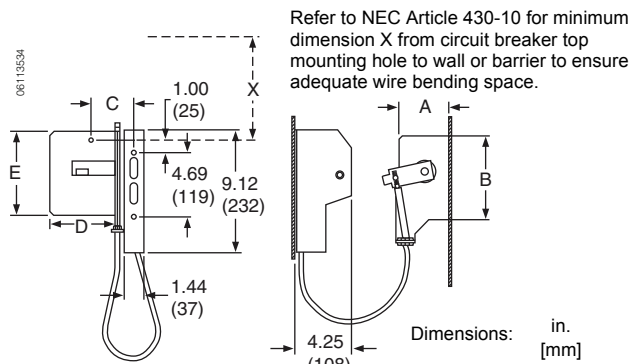

Note: Bend radius in cable must never be less than 6 in. (152 mm). Electrical clearances must be maintained between cable and live electrical parts.

PowerPact® H- and J-Frame Circuit Breakers

Section 3—Accessories

Variable Depth Mechanisms

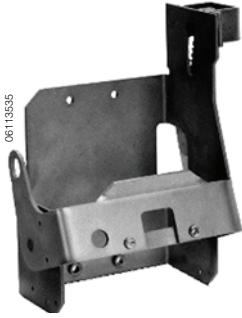

Designed for installation in custom built control enclosures where main or branch circuit protective devices are required.

- All circuit breaker operating mechanisms are suitable for either right- or left-hand flange mounting, convertible on the job.
- Variable mounting depth range: 5.88–17.75 in. (149–451 mm).
- Operating mechanism 9422RQ1 (does not include handle mechanism).

Circuit Breaker Enclosures and Enclosure Accessories

- Square D circuit breaker enclosures are UL Listed, CSA Certified and are suitable for use as service entrance equipment, except as footnoted.
- The short circuit rating of an enclosed circuit breaker is equal to the rating of the circuit breaker installed, except as footnoted.
- Circuit breakers are ordered and shipped separately for field installation.

Table 56: Enclosure Dimensions

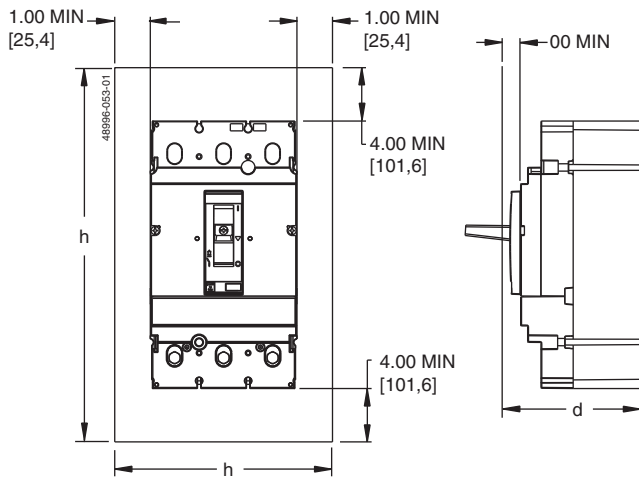

Circuit Breaker	Amperage	Enclosure Dimensions (h x w x d)	
		80%	100%
H-Frame	15–150 A	18.13 x 8.63 x 4.13 in. (461 x 219 x 105 mm)	62 x 14 x 22.5 in. (572 x 356 x 1575 mm)
J-Frame	150–250 A	28.5 x 12.38 x 5.38 in. (724 x 314 x 137 mm)	62 x 14 x 22.6 in. (572 x 356 x 1575 mm)

Table 57: Circuit Breaker Enclosure Catalog Numbers

Circuit Breaker			Enclosure Cat. No.				
Cat. No. Prefix	Rating	Poles	NEMA 1 Flush	NEMA 1 Surface	NEMA 3R ¹	NEMA 4, 4X, 5, 3, 3R Stainless Steel	NEMA 12/3R, 5 (Without Knockouts) ²
HDL,HGL,HJL,HLL	15–150 A	2, 3	J250F	J250S	J250R	J250DS	J250AWK
JDL,JGL,JJL,JLL	150–250 A	2, 3					
HDL	15–100 A	3	—	HD100S ^{3, 4, 5}	—	—	—
JDL	150–250 A	3	—	JD250S ^{3, 5, 6}	—	—	—

¹ Enclosures with NRB or RB suffix have provisions for 3/4 in. through 2-1/2 in. bolt-on hubs in top endwall. Enclosures with R suffix have blank endwalls and require field cut opening. For details and hub catalog numbers see Digest 174 page 3-9.

² Suitable for rainproof NEMA 3R application by removing drain screw from bottom endwall.

³ Copper wire only

⁴ Maximum short circuit rating is 25 kAIR, 240 Vac

⁵ Order service ground kit PKOGTA2 if required.

⁶ Maximum short circuit rating is 18 kAIR, 480 Vac.

PowerPact® H- and J-Frame Circuit Breakers

Section 3—Accessories

Table 58: Dimensions

Cat. No.	Approximate Dimension						
	Series	H		W		D	
HD100S	A01	17.00 in.	431.8 mm	7.90 in.	200.7 mm	4.75 in.	120.7 mm
J250F	A01	32.40 in.	823 mm	15.40 in.	391 mm	6.00 in.	152 mm
J250S	A01	31.36 in.	797 mm	14.36 in.	365 mm	6.00 in.	152 mm
J250R	A01	31.05 in.	789 mm	14.47 in.	368 mm	6.28 in.	160 mm
J250DS	A01	32.26 in.	819 mm	9.72 in.	247 mm	7.94 in.	202 mm
J250AWK	A01	32.26 in.	819 mm	9.72 in.	247 mm	7.94 in.	202 mm

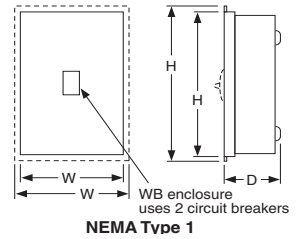

Table 59: Insulated Groundable Neutral Assembly

Circuit Breaker		Neutral Assembly For Use With		Terminal Lug Data—Total Available (Line plus Load) AWG/kcmil
Cat. No. Prefix	Ampere Rating	NEMA 1 & 3R	NEMA 4, 4X, 5, 12 & 12K	
		Cat. No.	Cat. No.	
HDL,HGL,HJL,HLL	15–100 A	SN100FA	SN100FA	(4) 14–1/0 Cu or (4) 12–1/0 Al
HDL,HGL,HJL,HLL	125–150 A	SN400LA	SN400LA	(2) 1–600 or (4) 1–250 Al/Cu, plus (2) 4–300 Al/Cu
JDL,JGL,JJL,JLL	150–250 A	SN400LA	SN400LA	(2) 1–600 or (4) 1–250 Al/Cu, plus (2) 4–300 Al/Cu

Table 60: Service Ground Kits

Circuit Breaker Cat. No. Prefix	Ground Bar Cat. No.	Number of Terminals	Conductors Per Terminal	Wire Range
HDL,HGL,HJL,HLL, JDL,JGL,JJL,JLL	PKOGTJ250	2	1	6 AWG–300 kcmil Al/Cu

Locking Systems

Padlocking systems can receive up to three padlocks with diameters of 0.19–0.31 in. (5–8 mm); padlocks not supplied.

Table 61: Device Locking Options

Control Device	Function	Type	Accessories Required	Kit Cat. No.
Toggle	Lock in OFF (O) Position	Padlock	Removable Device	S29370
	Lock in OFF (O) or ON (I) Position	Padlock	Fixed Device ¹	S29371
	Lock in OFF (O) Position	Padlock	Stationary Device	S37422
Direct Rotary Handle	Lock in OFF (O) Position	Padlock	None	—
Extended Rotary Operating Handle	Lock in OFF (O) Position, Door Opening Prevented	Padlock	None	—
Motor Operator	Lock in OFF (O) Position, Motor	Padlock	None	—

¹ Not available for 2P HD and HG devices

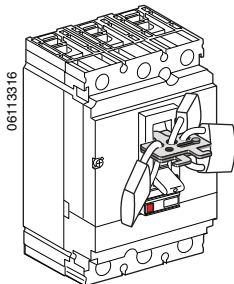

Removable Attachment*

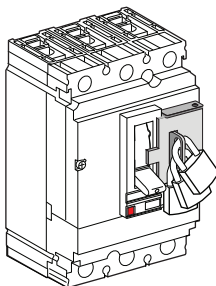

Fixed Padlock Attachment

Interlocking Systems

Interlocking of Circuit Breakers With Toggle Control

The toggle interlock system can receive one or two padlocks with diameters of 0.19–0.31 in. (5–8 mm). Both interlocked circuit breakers should be fixed version or plug-in version. Two sliding interlocking bars can be used to interlock three circuit breakers installed side-by-side, in which case one circuit breaker is in the ON (I) position and the two others in the OFF (O) position. (Kit S29354. Not available for 2P HD and HG devices.)

Interlocking Two Circuit Breakers with Rotary Handles

The rotary handles are padlocked with the devices in the OFF (I) position. The interlock mechanism inhibits the two devices from being closed (ON/I) at the same time, but allows for both devices to be open (OFF/O) simultaneously. (Kit S29369. Not available for 2P HD and HG devices.)

Figure 12: Interlocking Systems

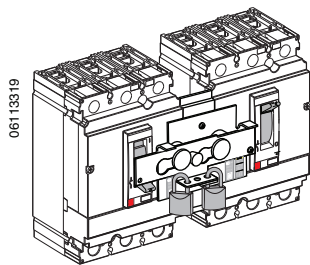

Interlocking with Toggle Control (S29354)

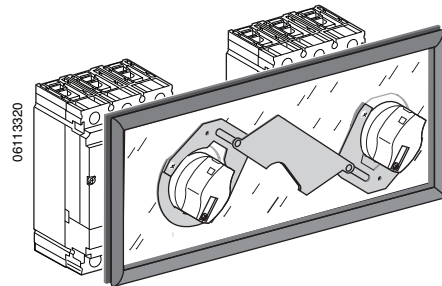

Interlocking with Rotary Handles (S29369)

Section 4—Wiring Diagrams

Table 62: Connector Descriptions

	Function	Description	Connector
	Auxiliary Contacts	Open/Closed circuit breaker or switch position contacts	OF/AX
		Bell alarm	SD/AL
	Remote Operation	Undervoltage trip device	MN/UVR
		Shunt trip	MX/SHT
	Remote Operation	Motor operator	MCH

Figure 13: Control Wiring Diagrams

Function	Connector	Description
Auxiliary Contacts	OF/AX	Open/Closed circuit breaker or switch position contacts
	SD/AL	Bell alarm
Remote Operation	MN/UVR	Undervoltage trip device
	MX/SHT	Shunt trip
	MCH	Motor operator

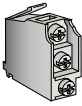
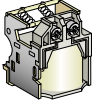
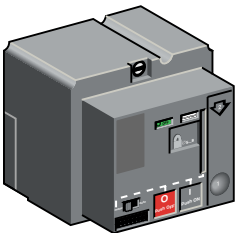
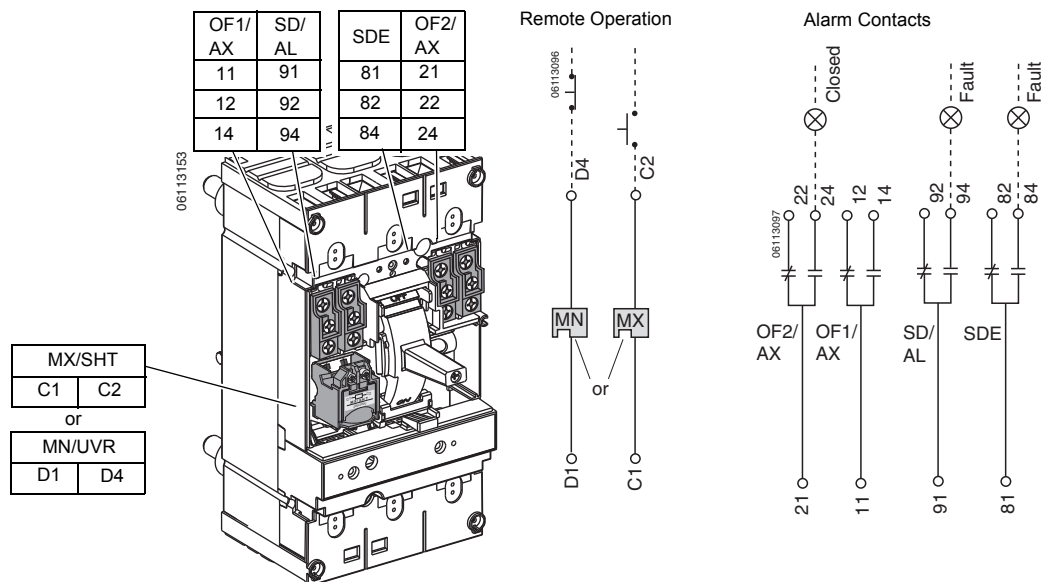

PowerPact® H- and J-Frame Circuit Breakers

Section 4—Wiring Diagrams

Standard Motor Operator Wiring (Factory Wiring Configuration)

A circuit breaker may be configured for remote operations. Remotely operated circuit breakers are factory wired for the power supply to the motor being switched by the overcurrent trip switch. This prevents the circuit breaker from being remotely reset after an overload fault as a precaution against closing on a fault.

Figure 14: Standard Motor Operator Control Wiring

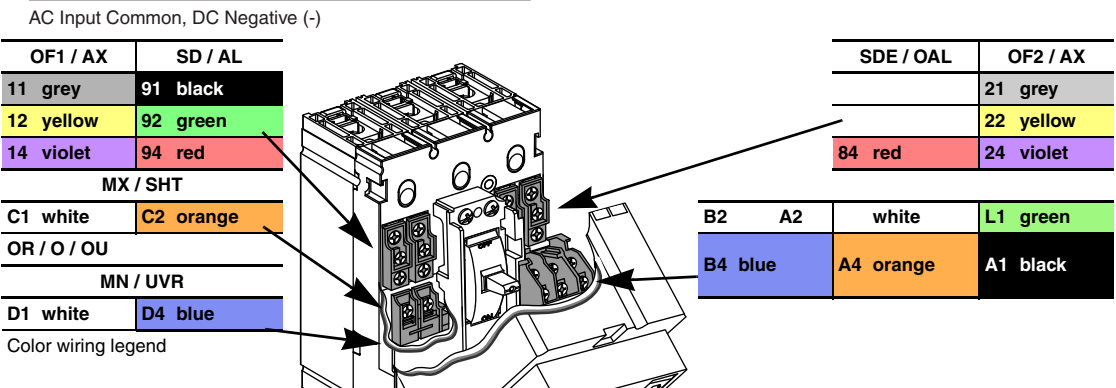
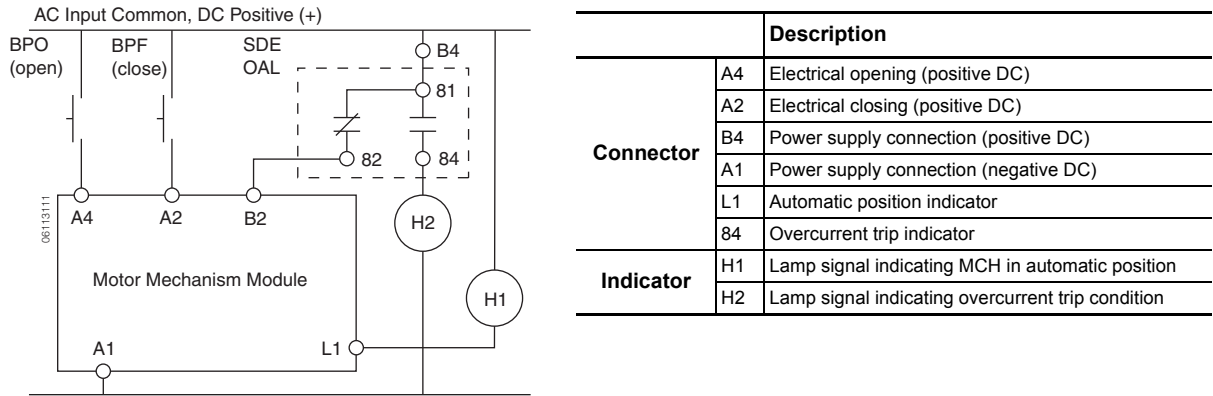

Remote Reset Wiring Without Overcurrent Trip Switch Protection

To configure circuit breaker for remote operation without overcurrent switch protection, follow the wiring diagram below.

Figure 15: Motor Operator Without Overcurrent Switch Protection

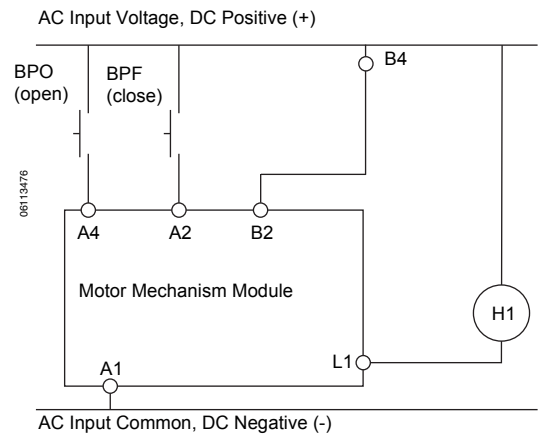

Section 5—Dimensions

H-Frame Dimensional Drawings

Figure 16: 15–150 A Bus Bar H-Frame 2P HD/HG Circuit Breaker

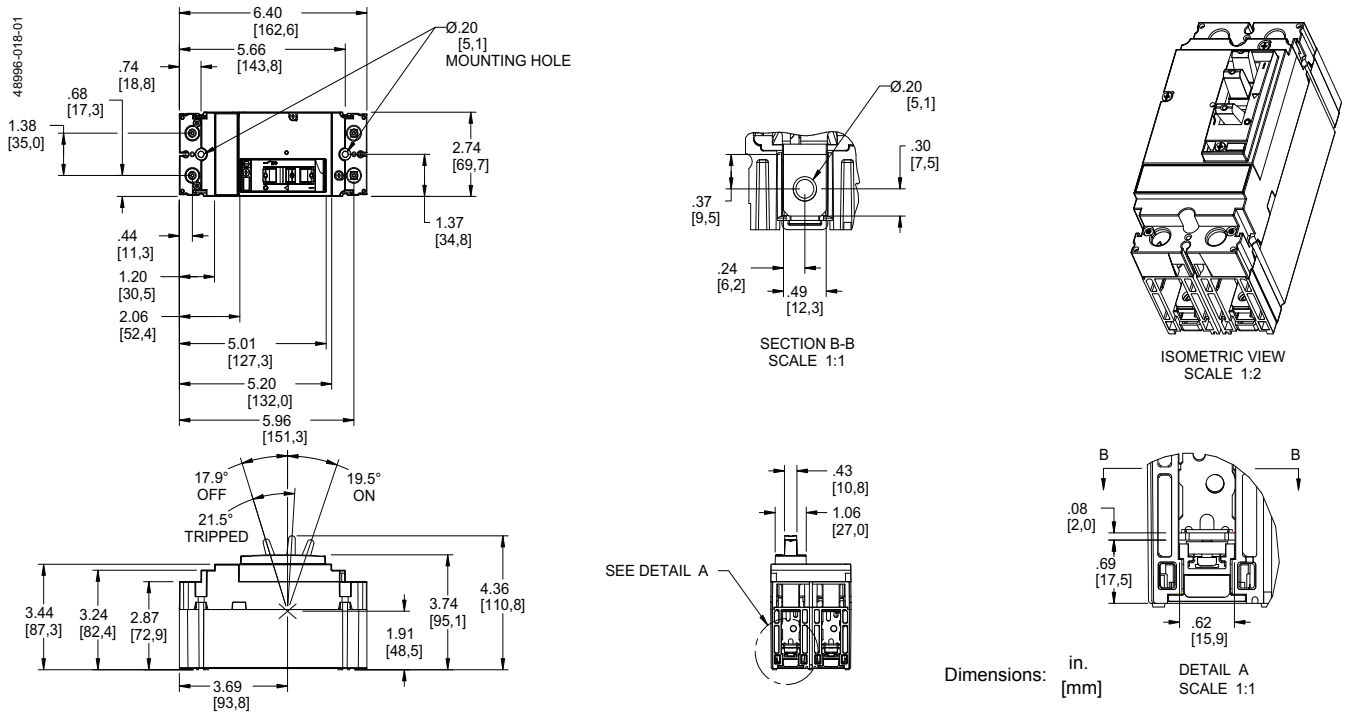

PowerPact® H- and J-Frame Circuit Breakers

Section 5—Dimensions

Figure 17: 15–150 A Unit Mount H-Frame 2P HD/HG Circuit Breaker

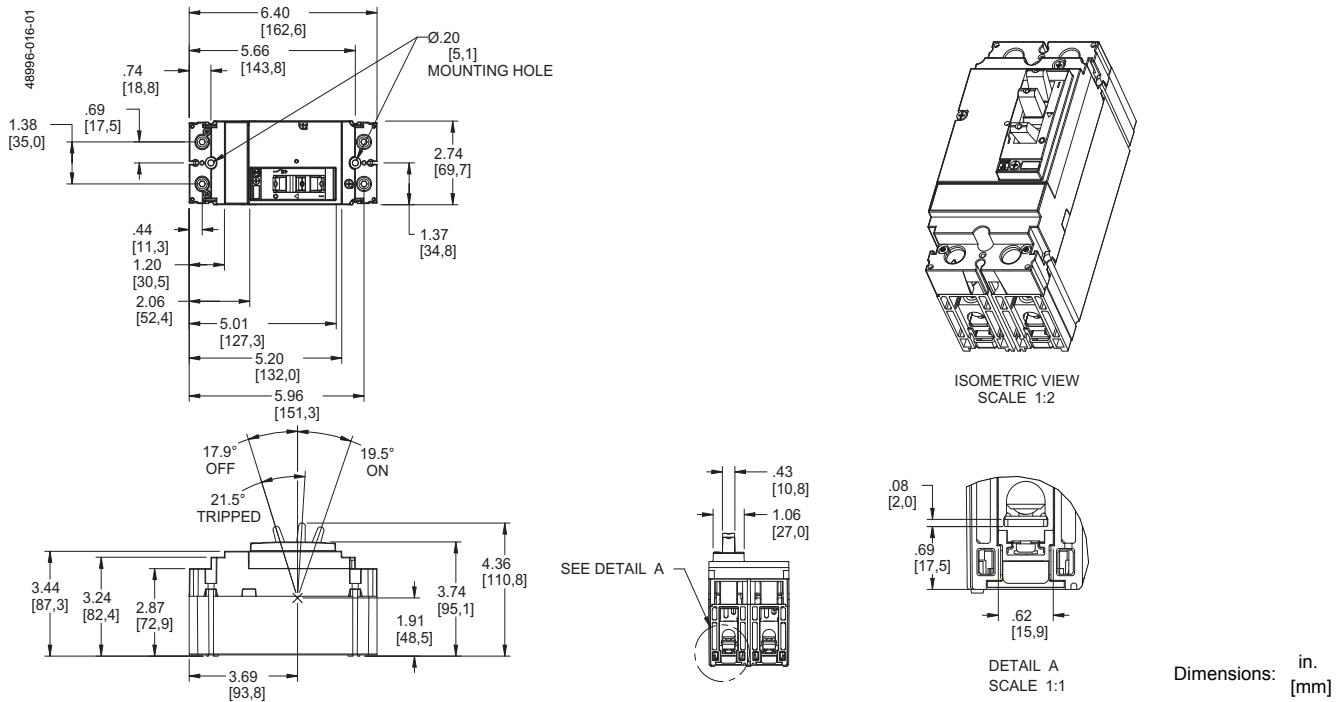
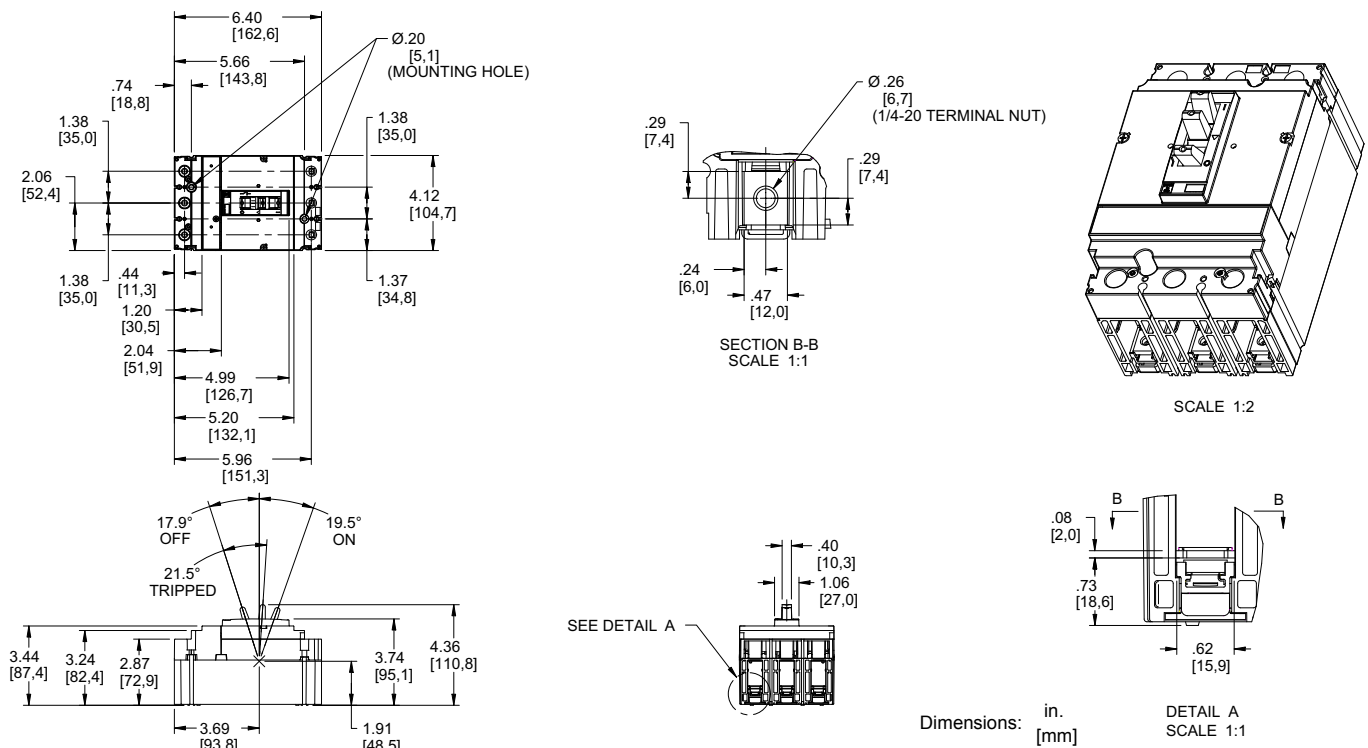

Figure 18: 15–150 A Bus Bar H-Frame 3P Circuit Breaker



PowerPact® H- and J-Frame Circuit Breakers

Section 5—Dimensions

Figure 19: 15–150 A Lug-Lug H-Frame 3P Circuit Breaker

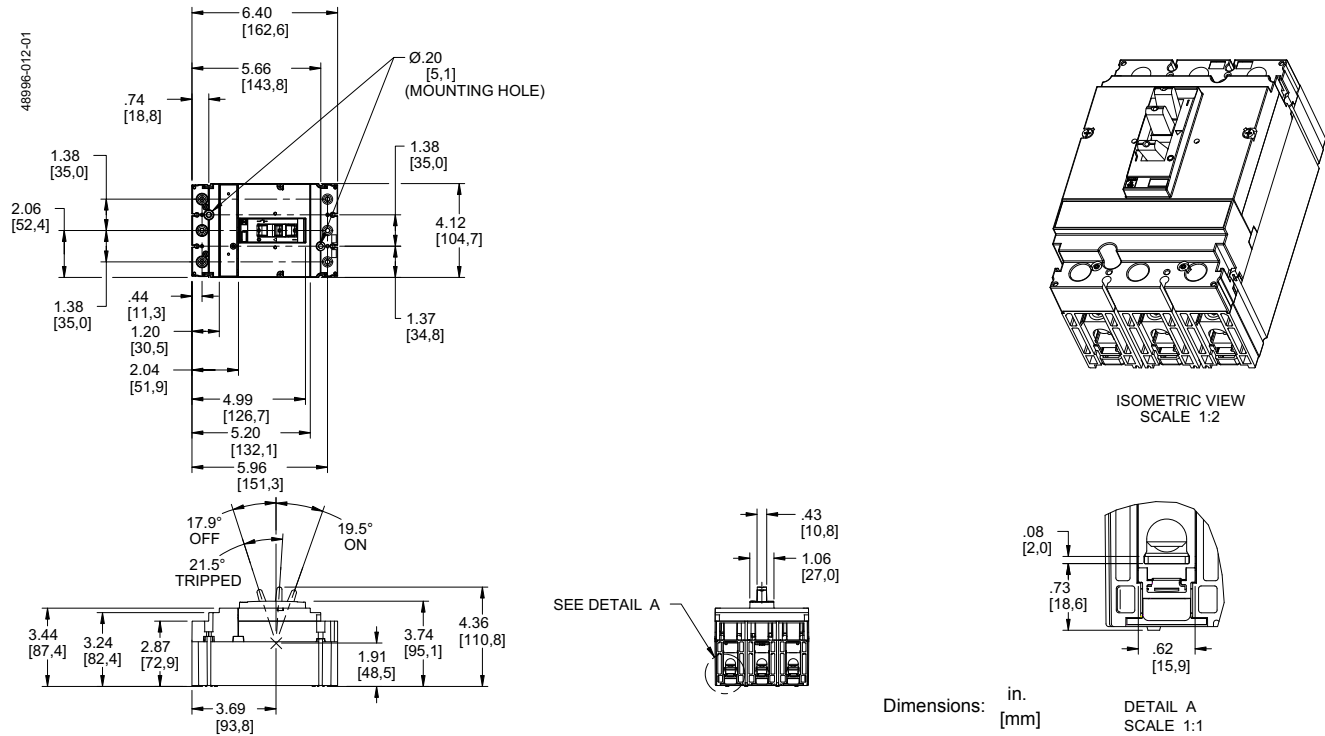
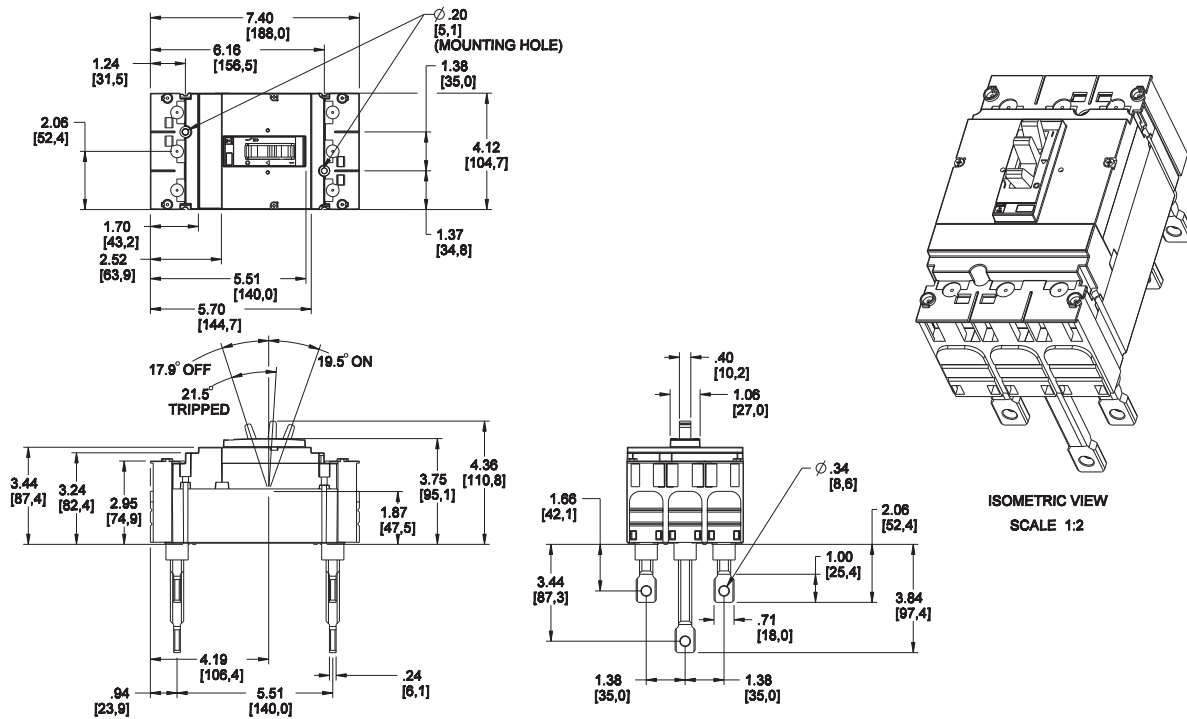

Figure 20: 15–150 A Rear Connected H-Frame 3P Circuit Breaker



PowerPact® H- and J-Frame Circuit Breakers

Section 5—Dimensions

Figure 21: Motor Operator Detail (H-Frame)

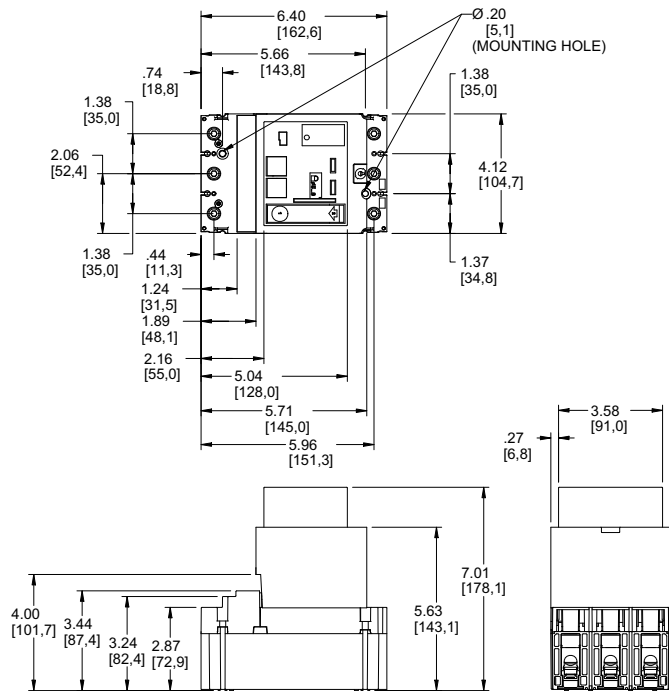
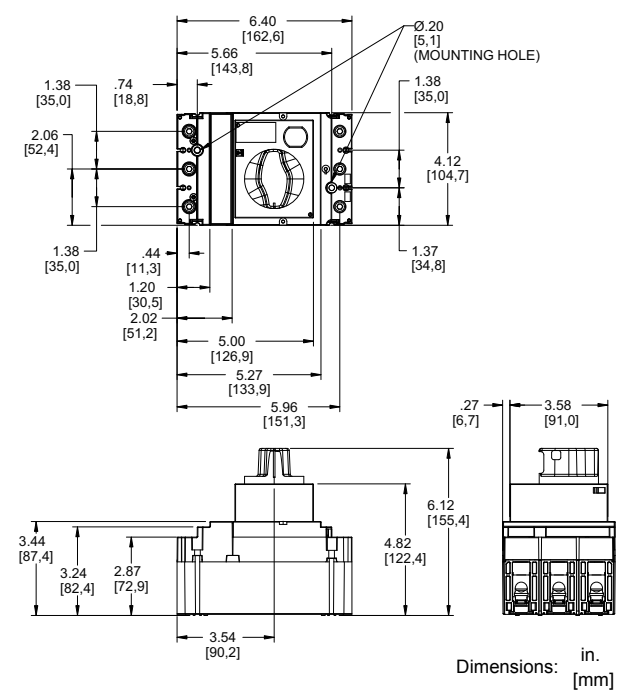

Figure 22: Rotary Handle Detail (H-Frame)



Dimensions: in. [mm]

J-Frame Dimensional Drawings

Figure 23: 150–250 A Bus Bar J-Frame 3P Circuit Breaker

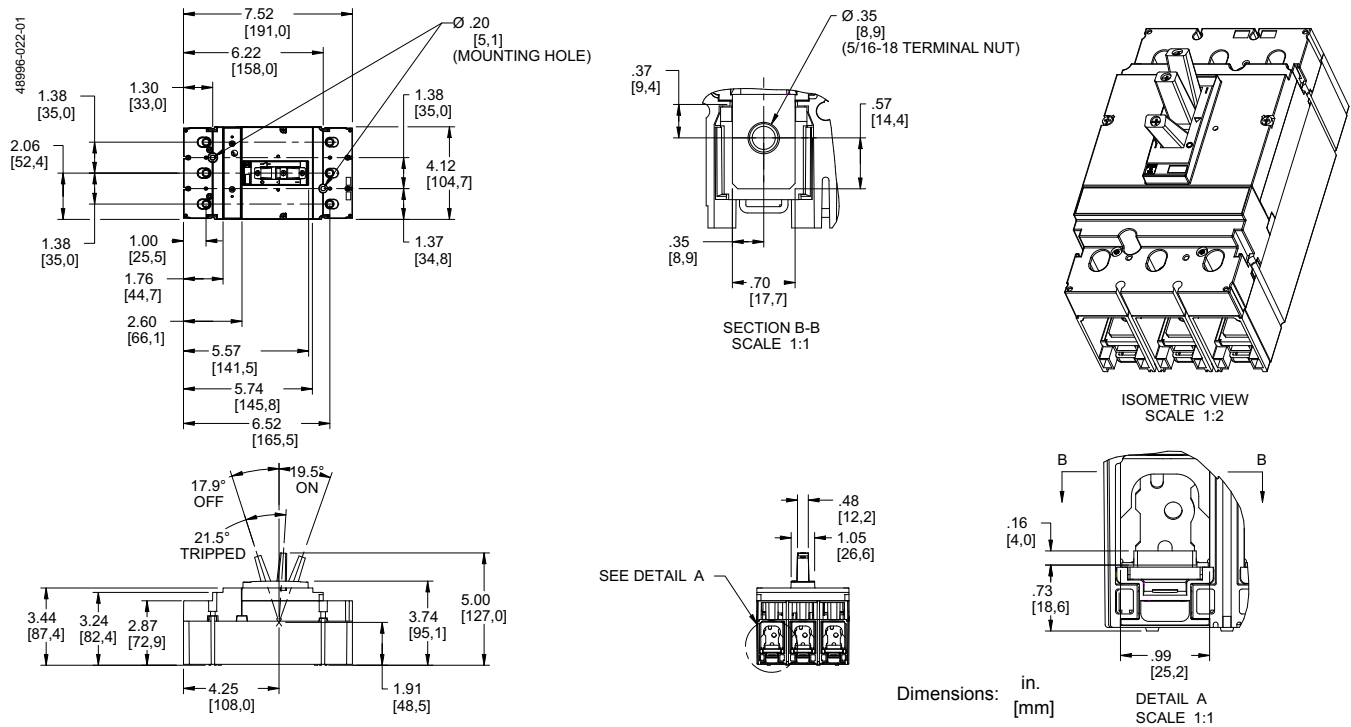
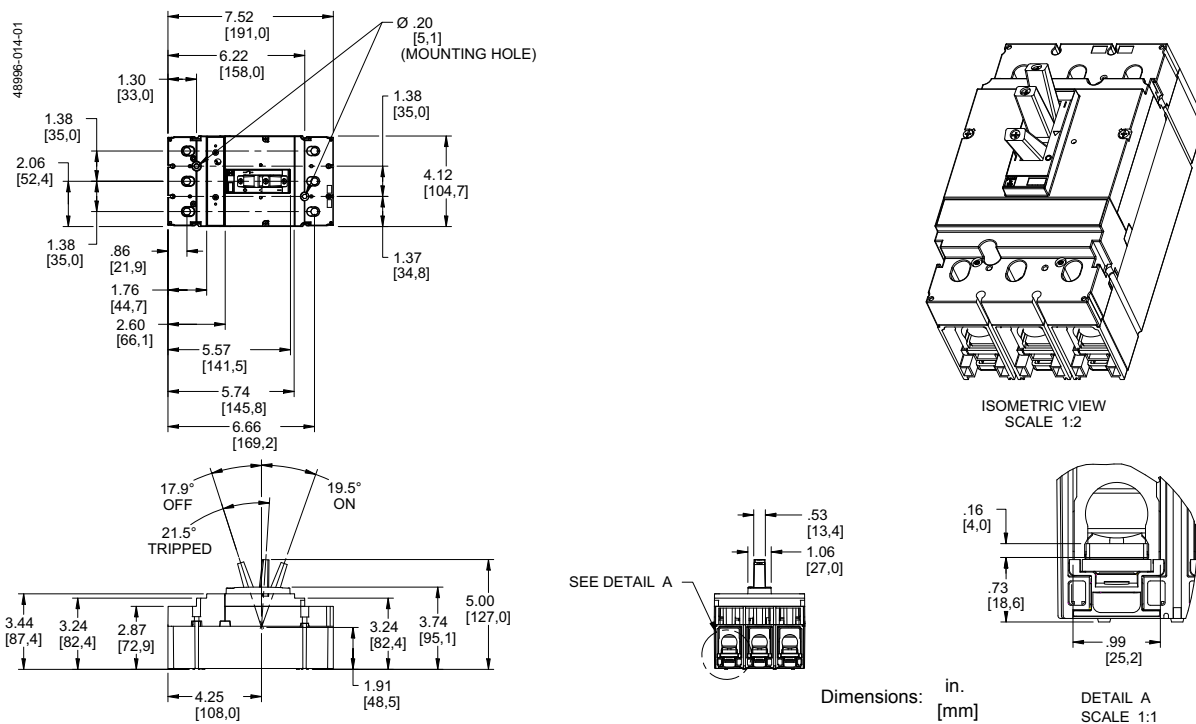

Figure 24: 150–250 A Lug-Lug J-Frame 3P Circuit Breaker



PowerPact® H- and J-Frame Circuit Breakers

Section 5—Dimensions

Figure 25: 150–250 A Rear Connected J-Frame 3P Circuit Breaker

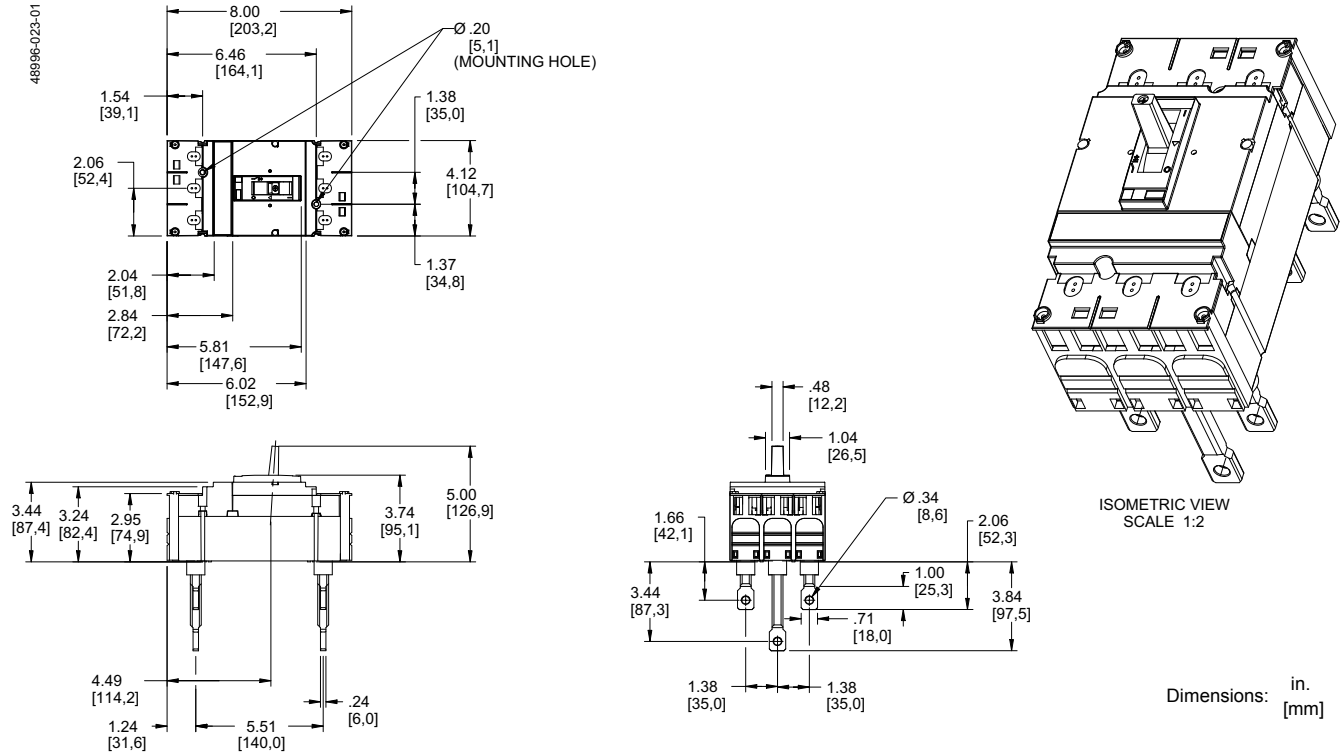

Figure 26: J-Frame Motor Operator Detail

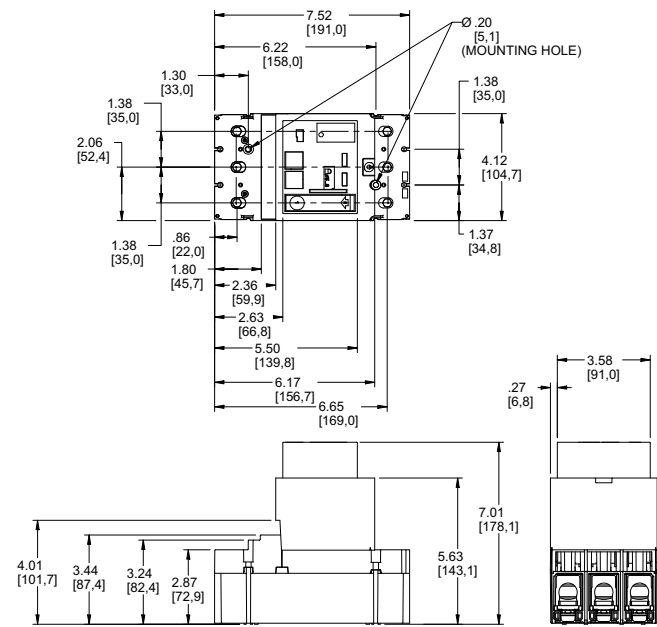
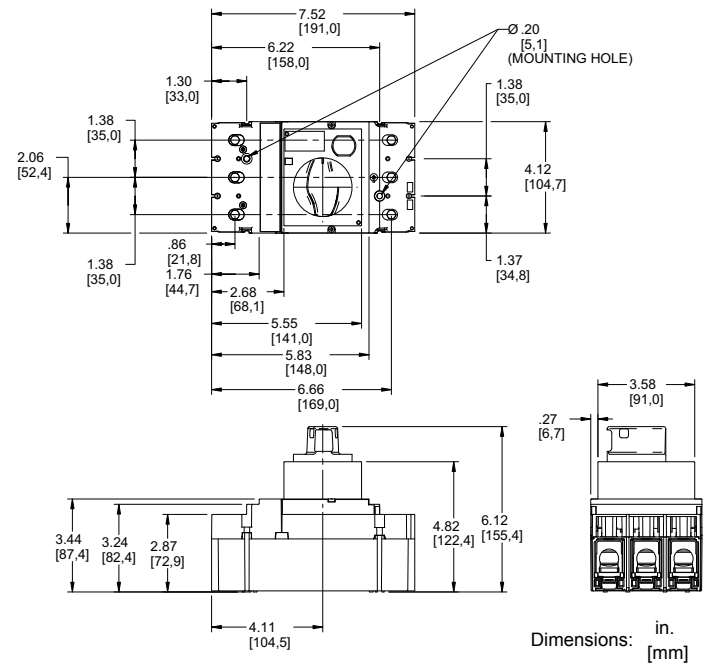

Figure 27: J-Frame Rotary Handle Detail



Plug-In H- and J-Frame Dimensional Drawings

Figure 28: 15–250 A H- and J-Frame Plug-In Base 3P Circuit Breaker

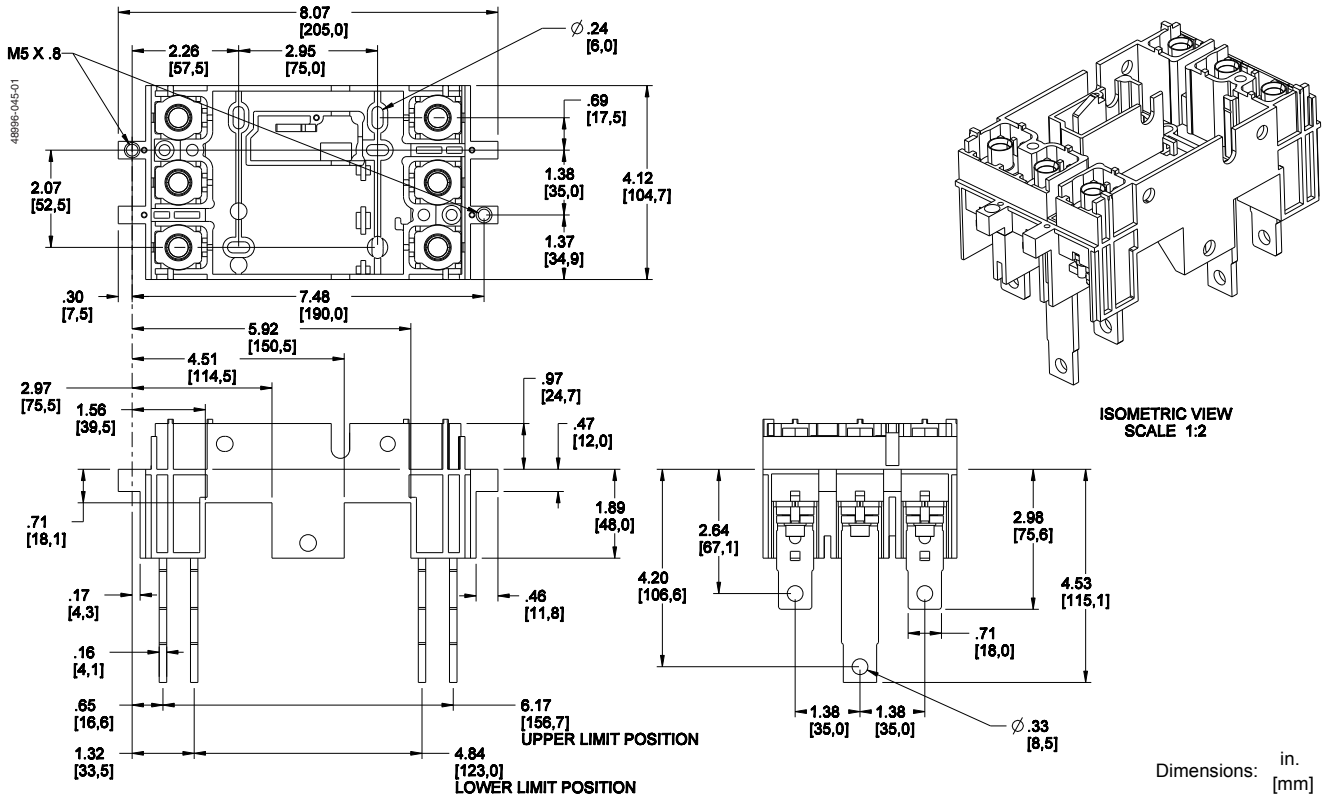
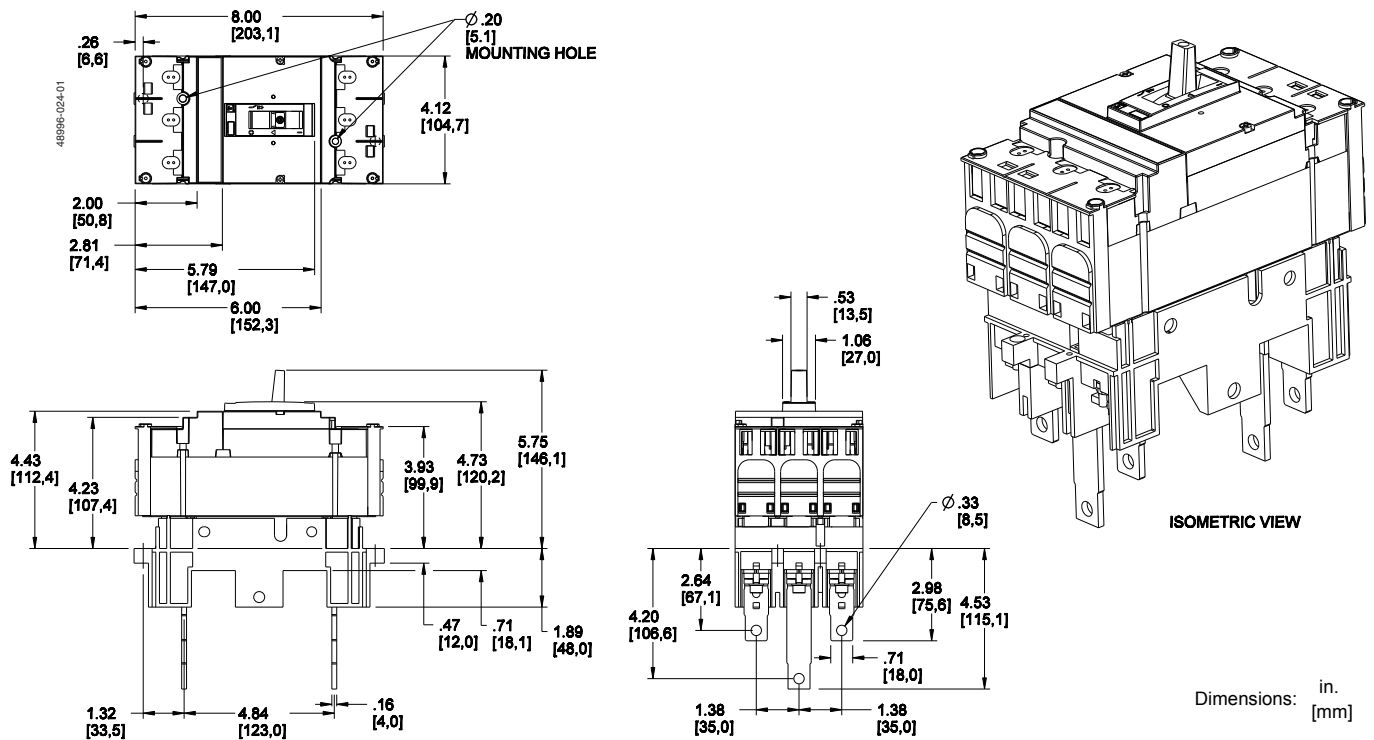

Figure 29: 15–250 A H- and J-Frame Plug-In Circuit Breaker 3P Circuit Breaker



PowerPact® H- and J-Frame Circuit Breakers
Section 5—Dimensions

Drawout H- and J-Frame Dimensional Drawings

Figure 30: 15–250 A H and J-Frame Cradle 3P Circuit Breaker

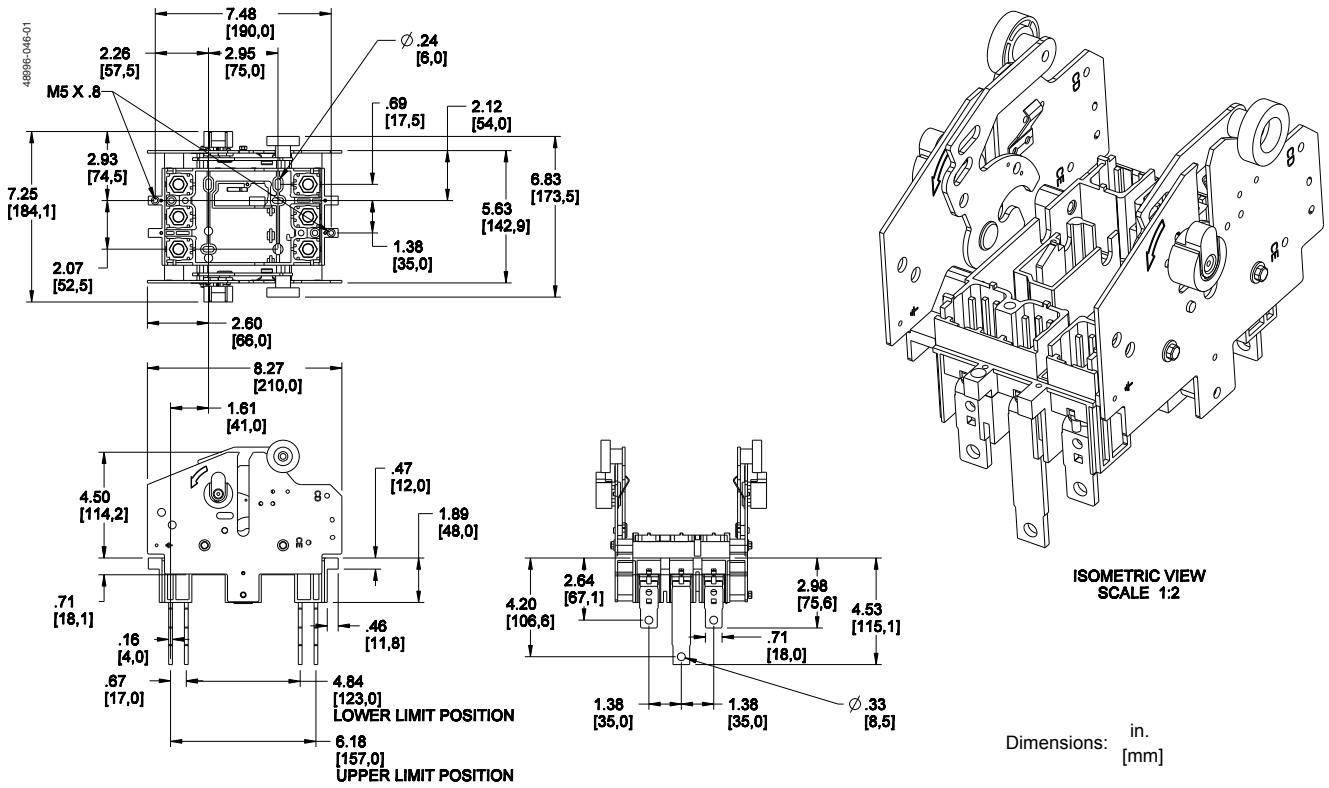
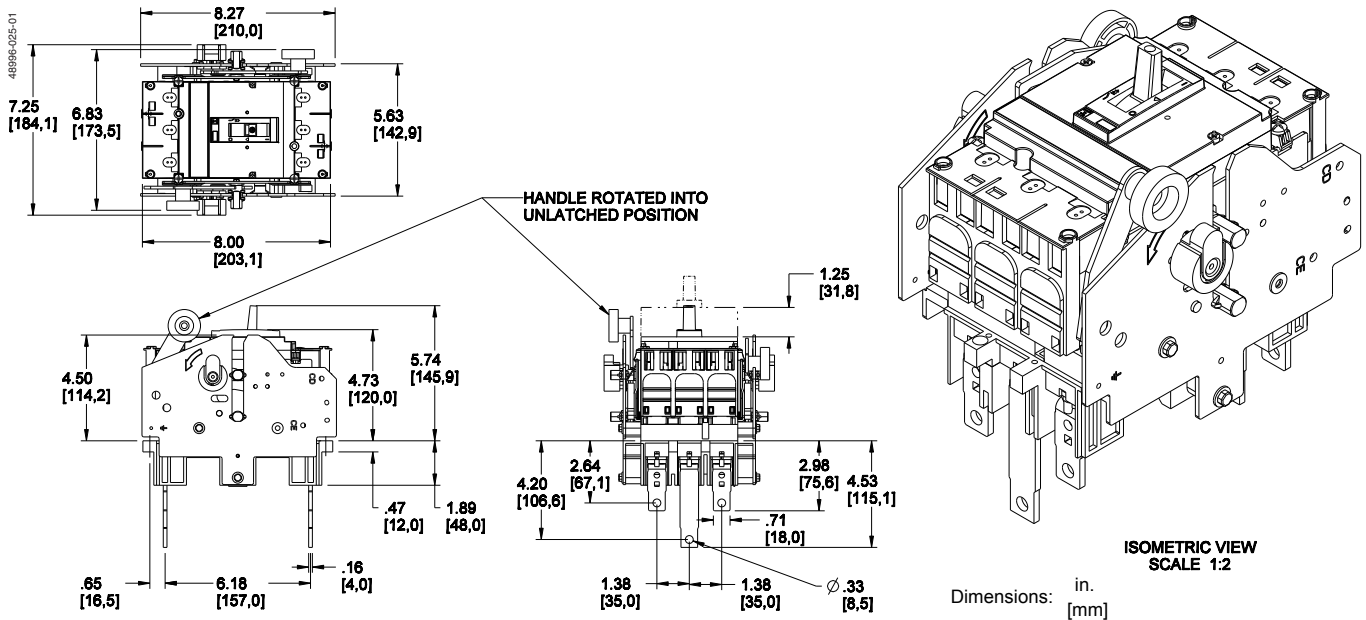
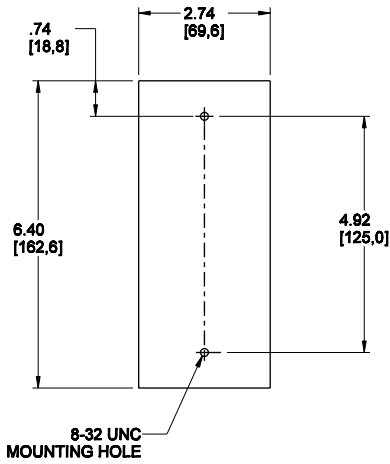

Figure 31: 15–250 A H- and J-Frame Drawout Circuit Breaker 3P Circuit Breaker



Mounting Dimensional Drawings

Figure 32: H-Frame 2P (HD and HG) Circuit Breaker



Dimensions: in.
[mm]

Figure 33: H and J-Frame 3P Circuit Breaker

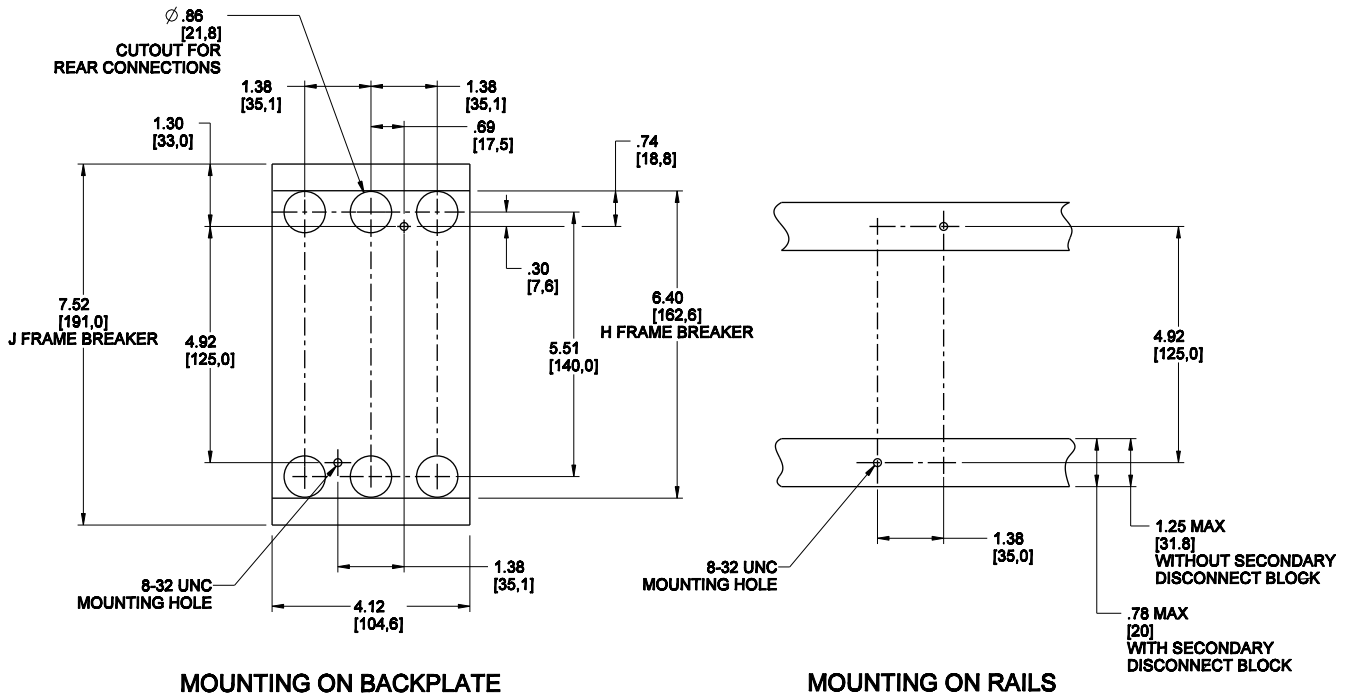

Dimensions: in.
[mm]

H- and J-Frame Door Cutout Dimensional Drawings

Figure 34: H and J-Frame Circuit Breaker Toggle Handle Door Cutout

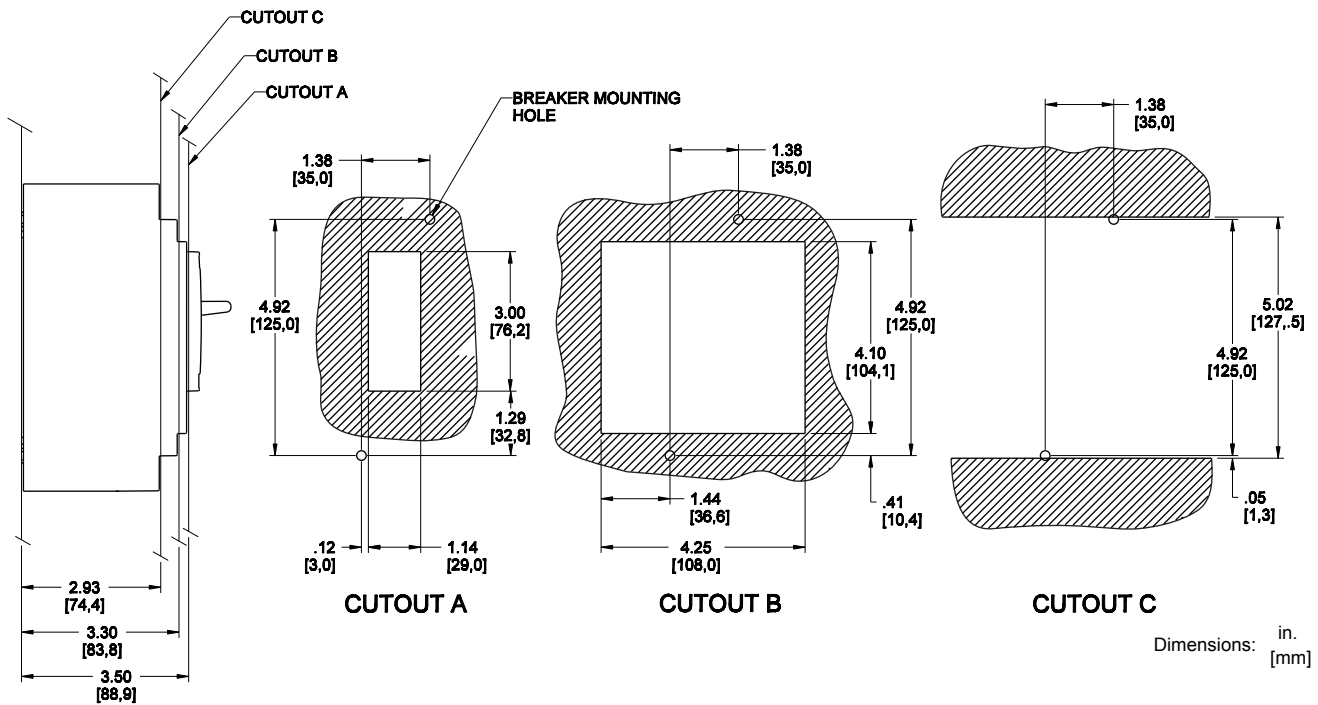

Figure 35: H and J-Frame Circuit Breaker Toggle Handle With Escutcheon Door Cutout

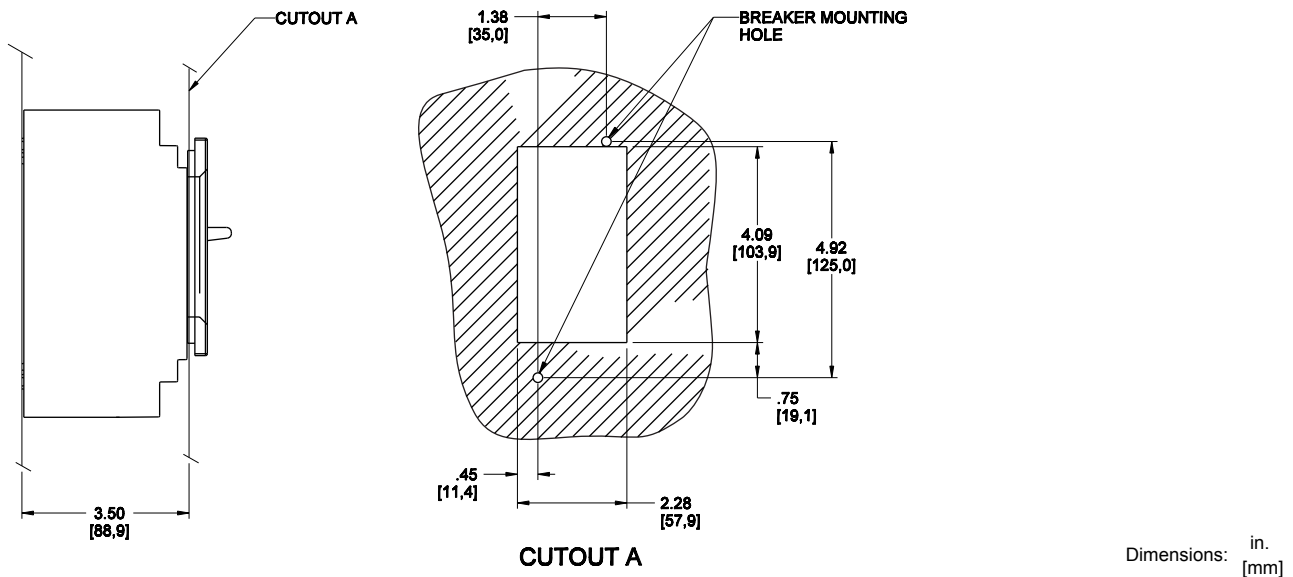

Figure 36: H and J-Frame Circuit Breaker Fixed Rotary Handle Cutout

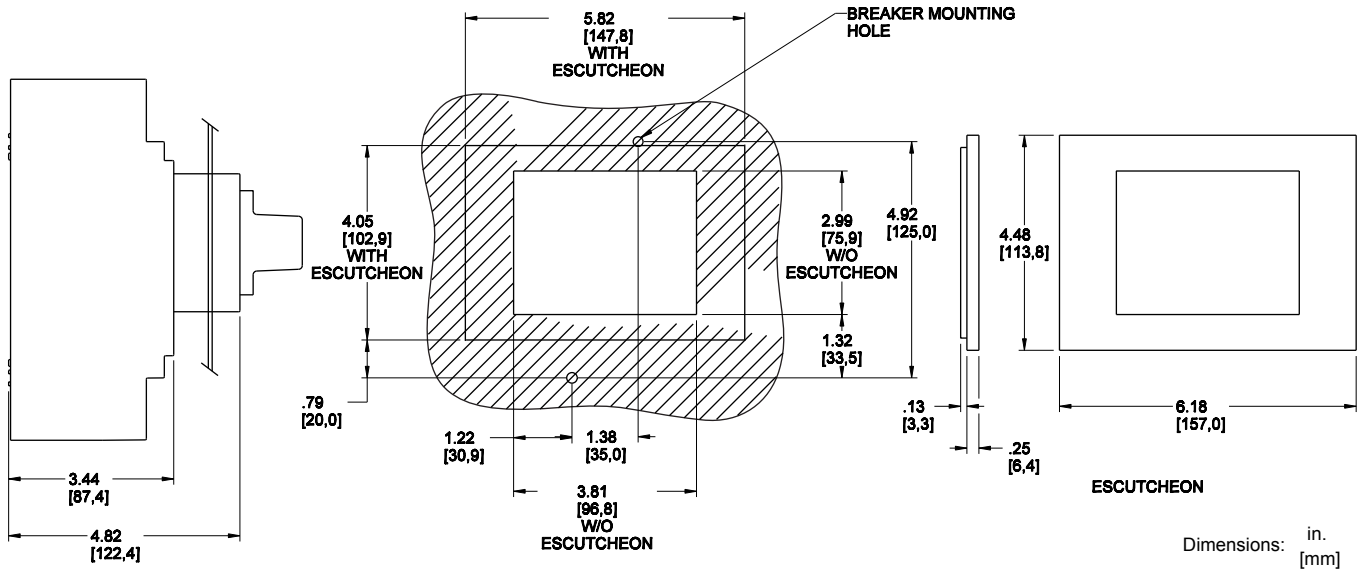
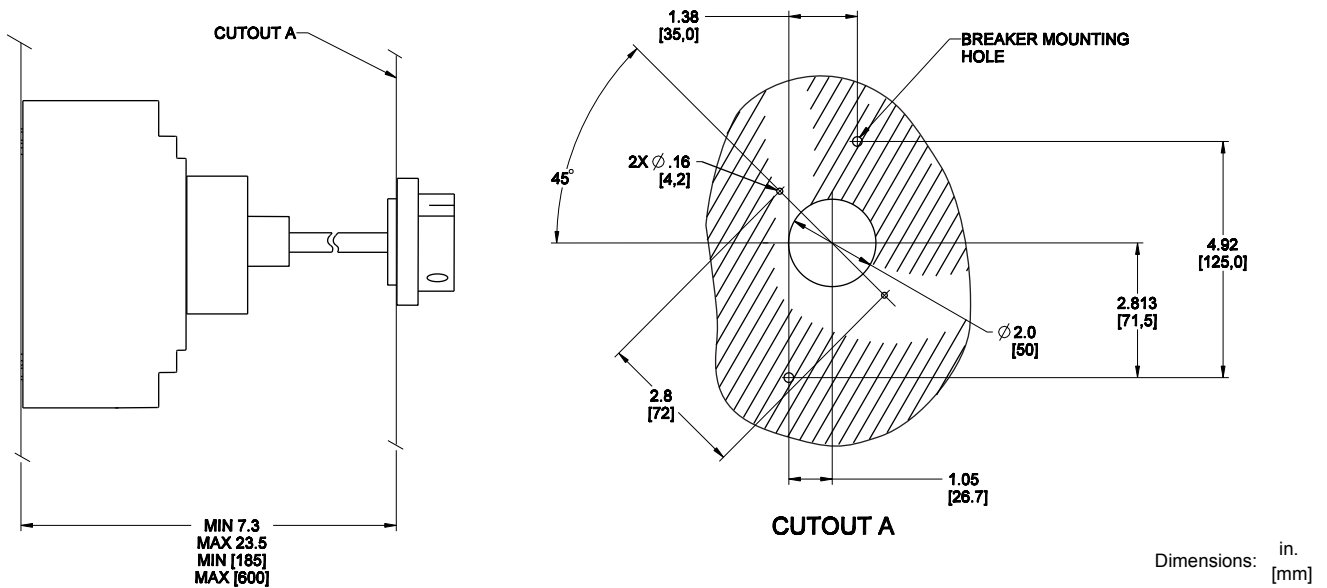

Figure 37: H and J-Frame Circuit Breaker Door Mounted Rotary Handle Cutout



PowerPact® H- and J-Frame Circuit Breakers

Section 5—Dimensions

Figure 38: H and J-Frame Circuit Breaker Motor Operator Cutout

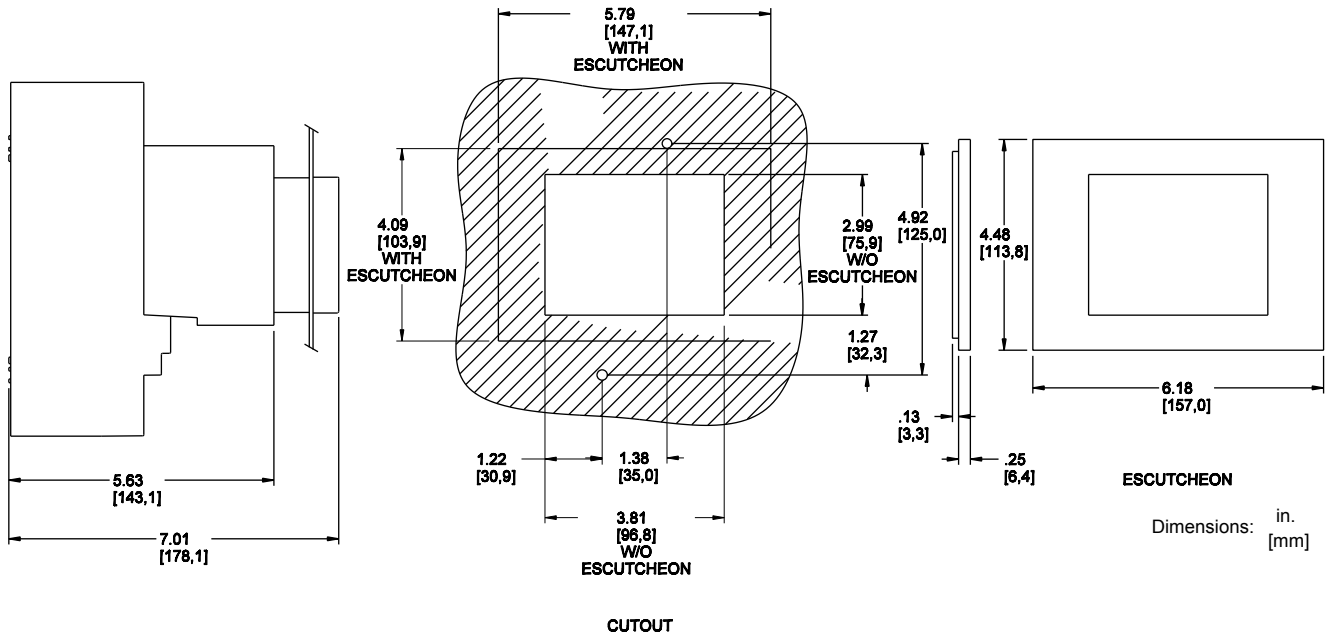

Section 6—Trip Curves

Figure 39: 15-35 A — HD, HG, HJ and HL

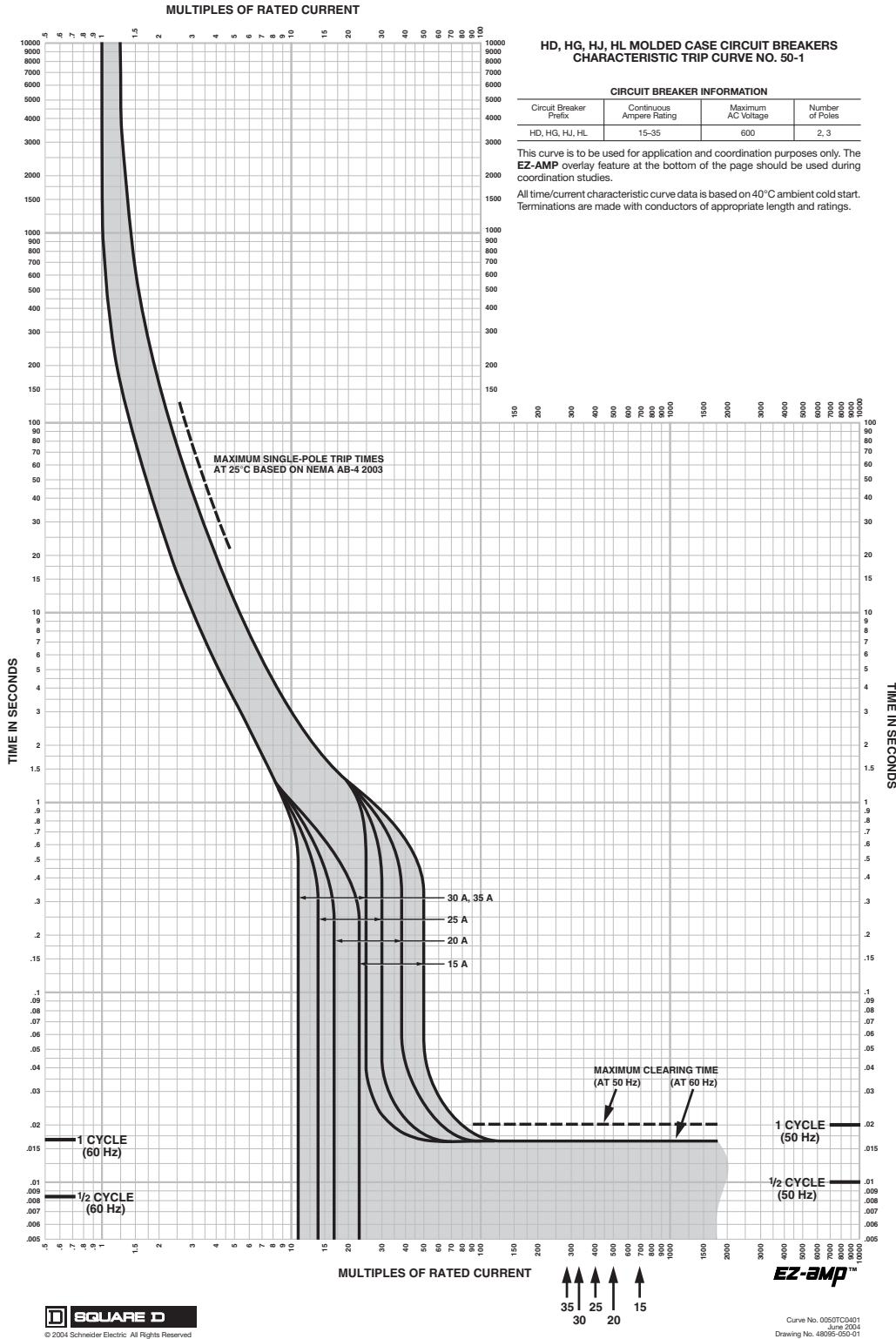

PowerPact® H- and J-Frame Circuit Breakers

Section 6—Trip Curves

Figure 40: 40-60 A — HD, HG, HJ and HL

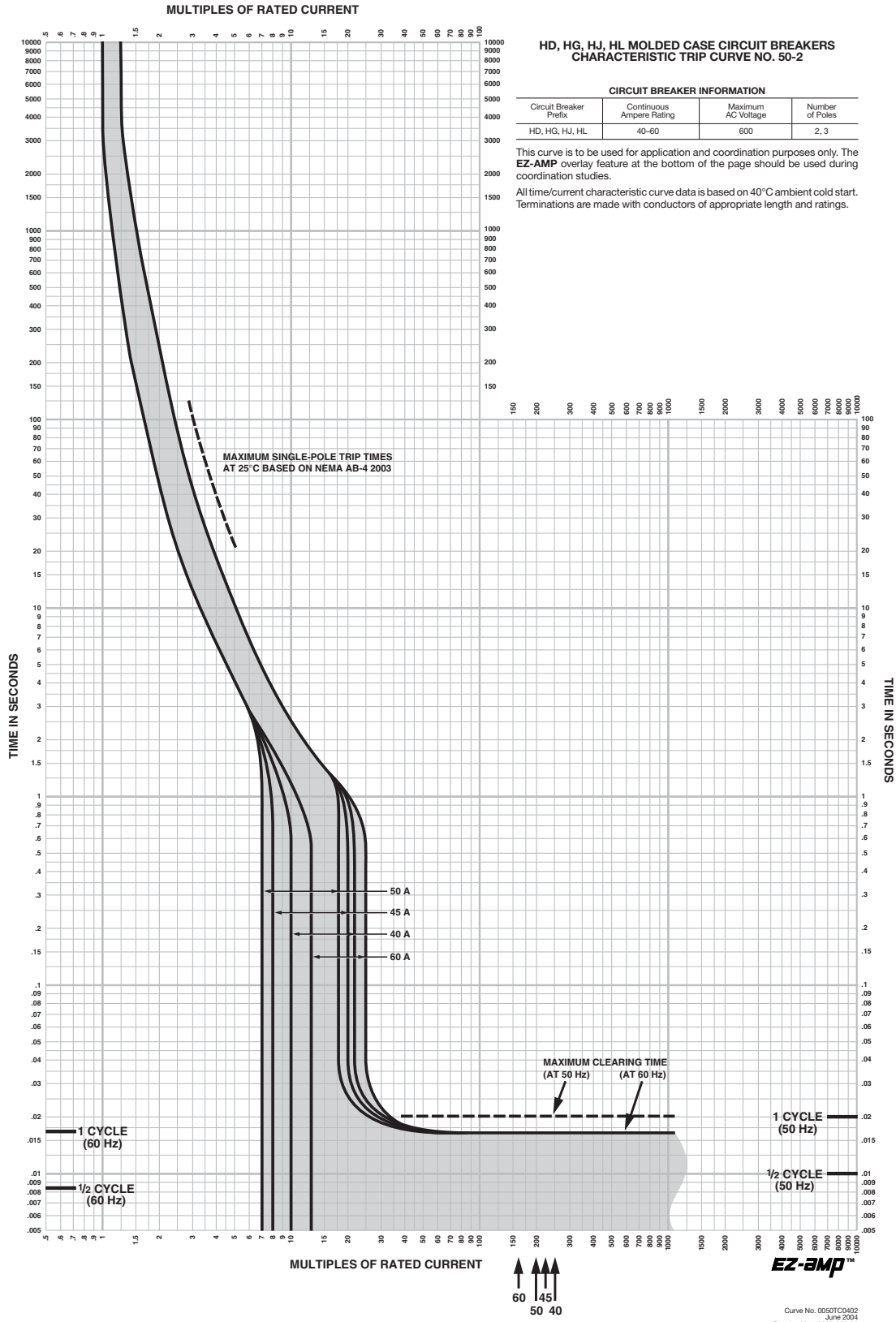

PowerPact® H- and J-Frame Circuit Breakers Section 6—Trip Curves

Figure 41: 70-100 A — HD, HG, HJ, and HL

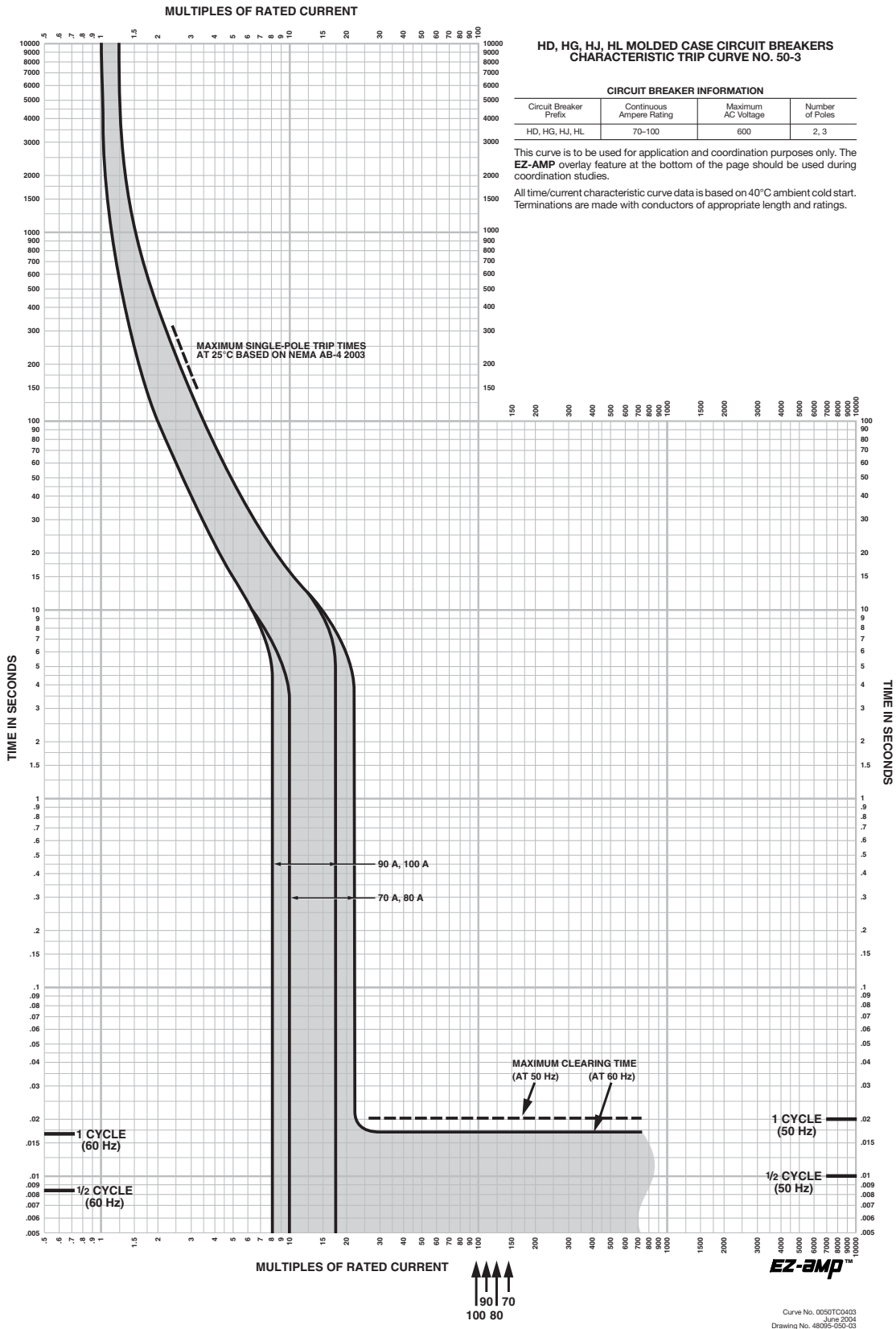

PowerPact® H- and J-Frame Circuit Breakers

Section 6—Trip Curves

Figure 42: 110-150 A — HD, HG, HJ, and HL

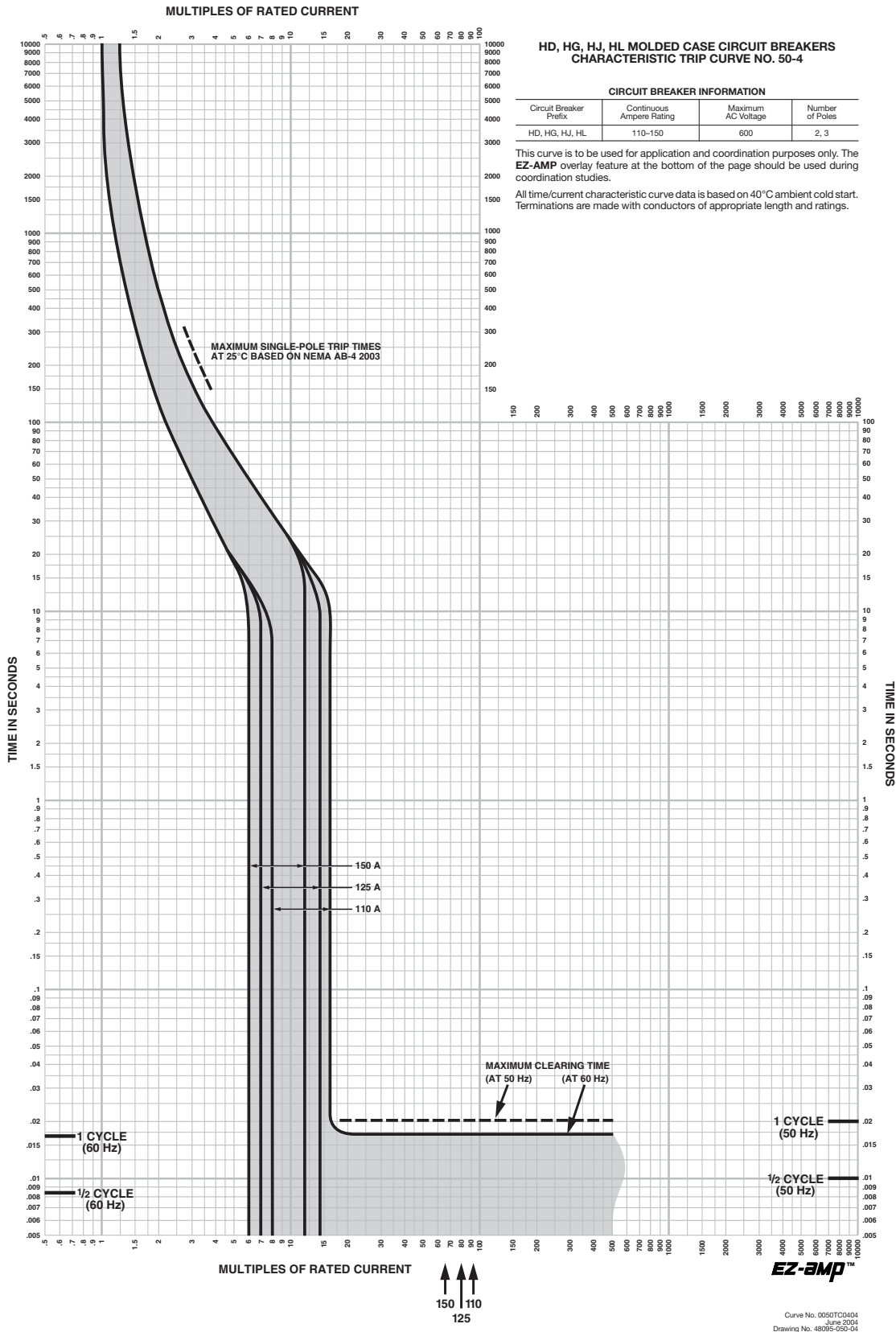

PowerPact® H- and J-Frame Circuit Breakers Section 6—Trip Curves

Figure 43: 150-250 A — JD, JG, JJ, and JL

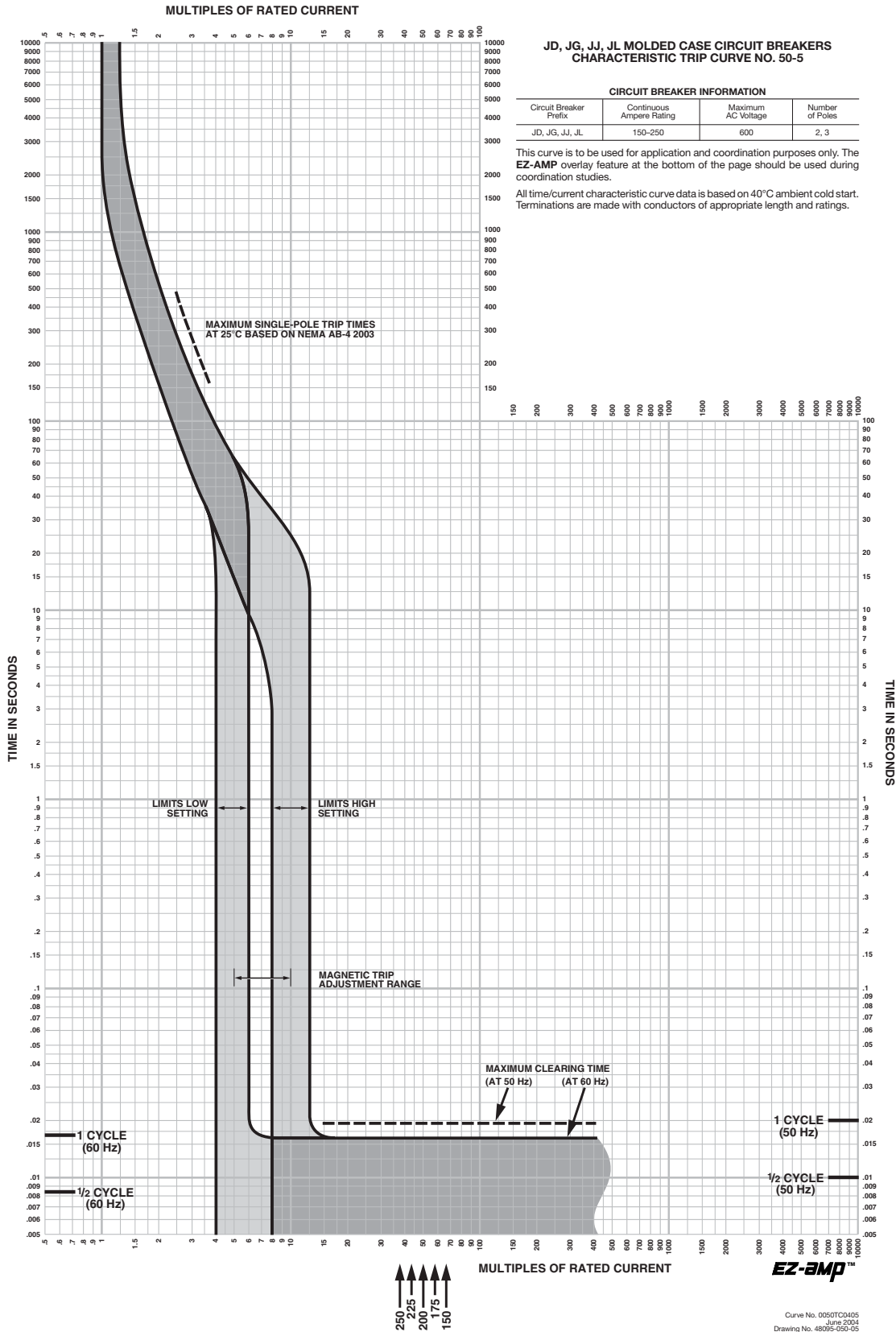

PowerPact® H- and J-Frame Circuit Breakers

Section 6—Trip Curves

Figure 44: H-Frame 150 A (HD, HG, HJ, and HL)

Curve No. 50-6 Let-Through I^2t
and 50-7 Peak Let-Through Current I_p

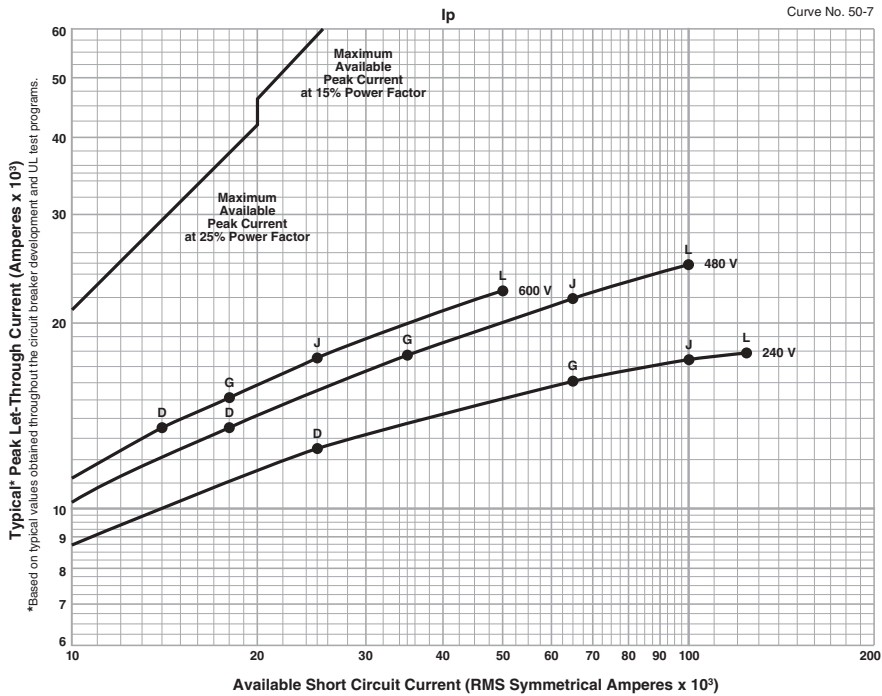
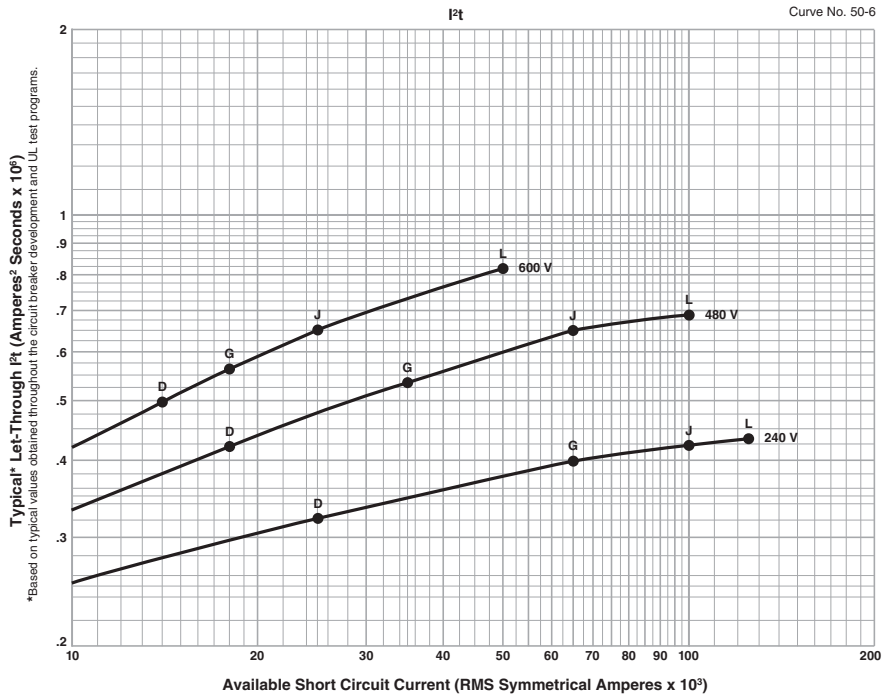
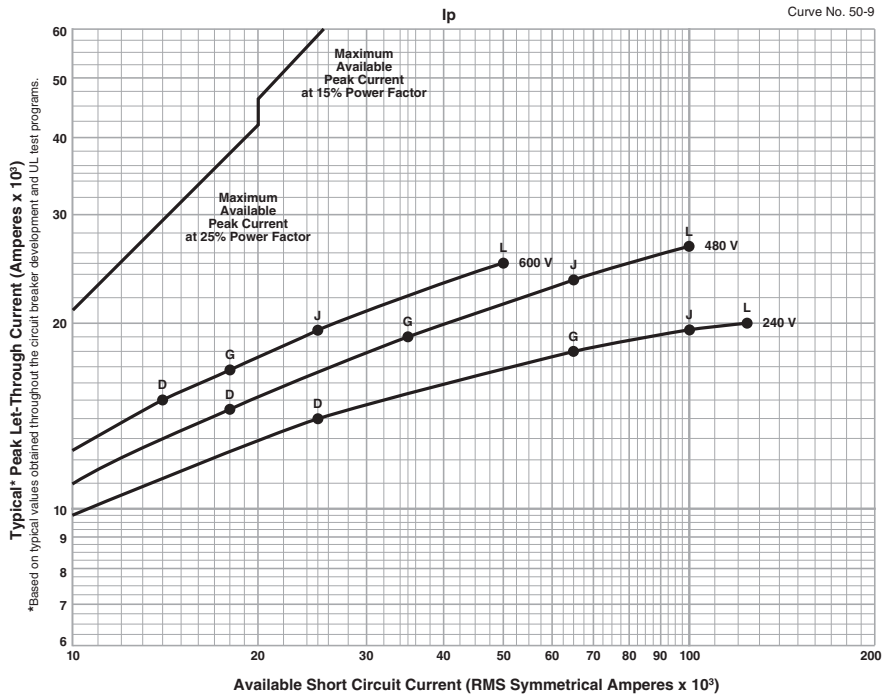
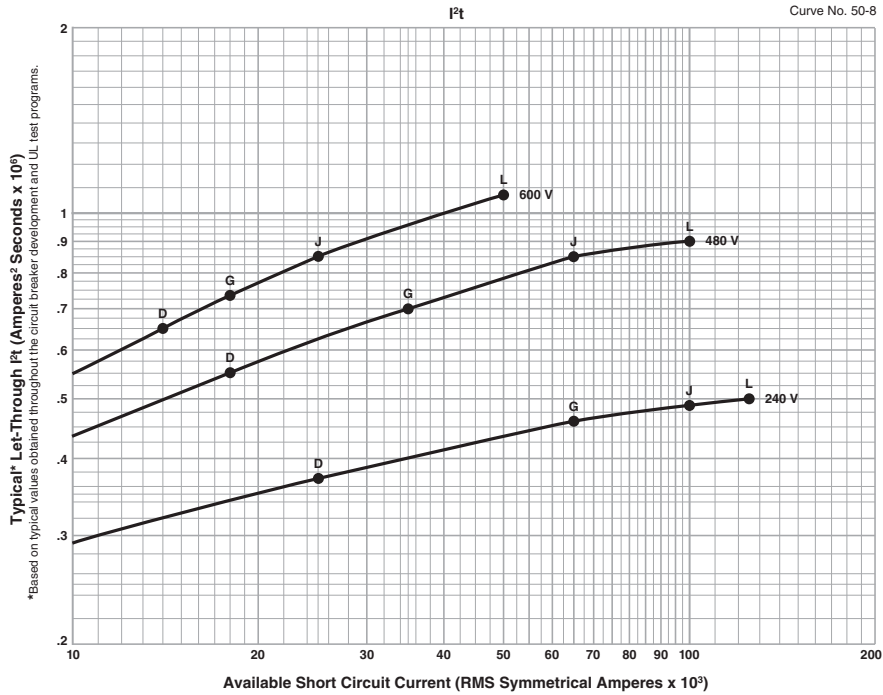

Figure 45: J-Frame 250 A (JD, JG, JJ, and JL)

Curve No. 50-8 Let-Through I^2t
and 50-9 Peak Let-Through Current I_p



PowerPact® H- and J-Frame Circuit Breakers

Section 6—Trip Curves

Figure 46: H- and J-Frame Motor Circuit Protector

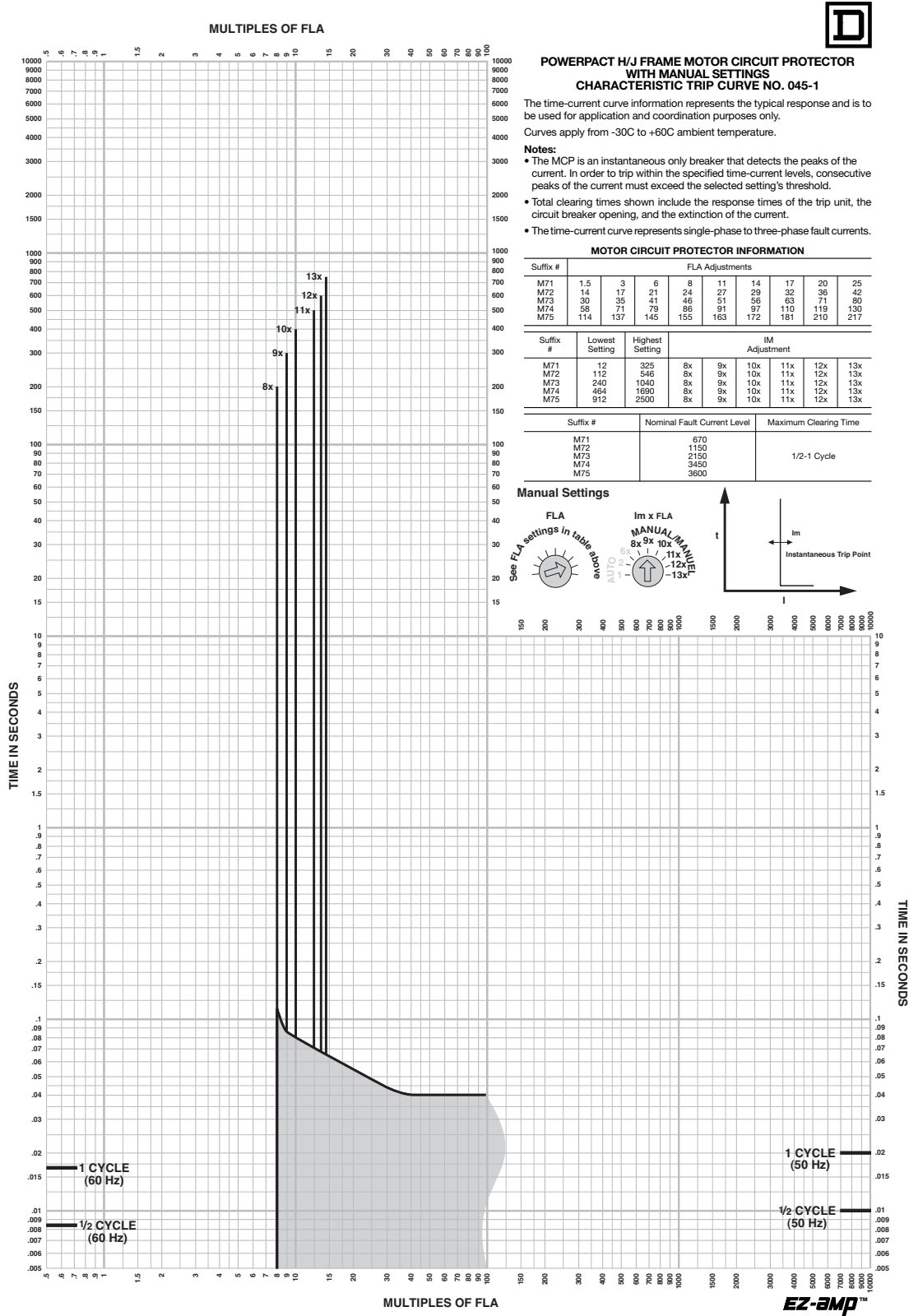

SQUARE D®
© 2006 Schneider Electric. All rights reserved.

Curve No. 0045TC0601
August 2006
Drawing No. 48095-045-01

PowerPact® H- and J-Frame Circuit Breakers

Section 6—Trip Curves

Figure 47: H- and J-Frame Motor Circuit Protector

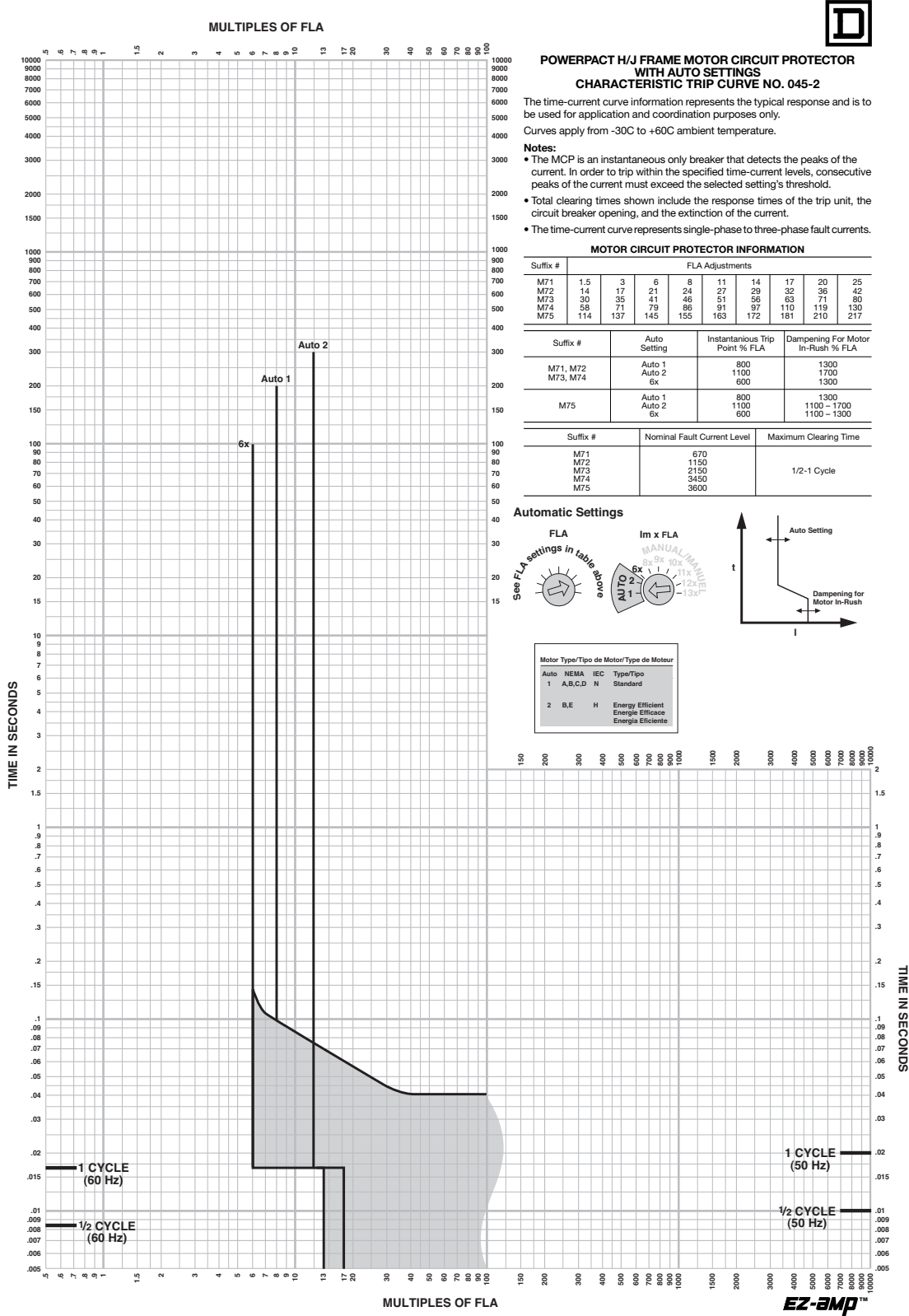

PowerPact® H- and J-Frame Circuit Breakers

Section 6—Trip Curves

Figure 48: Ground Fault Module GFM150HD Trip Curve

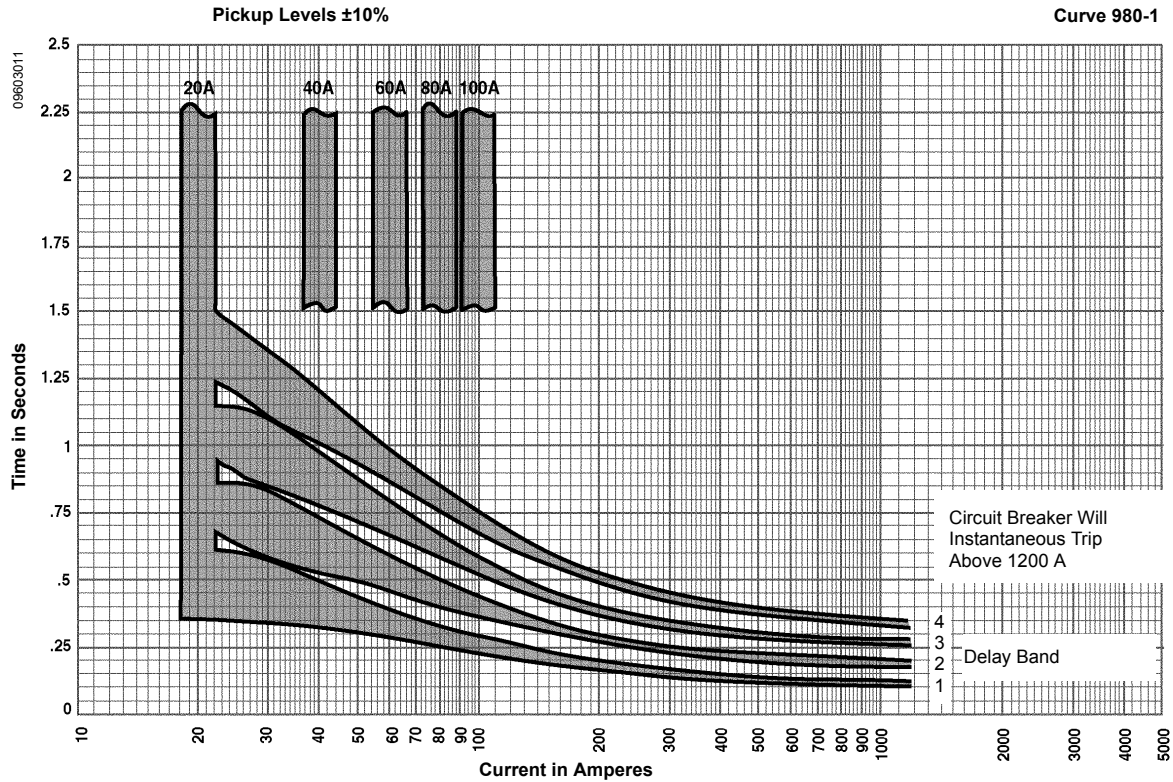
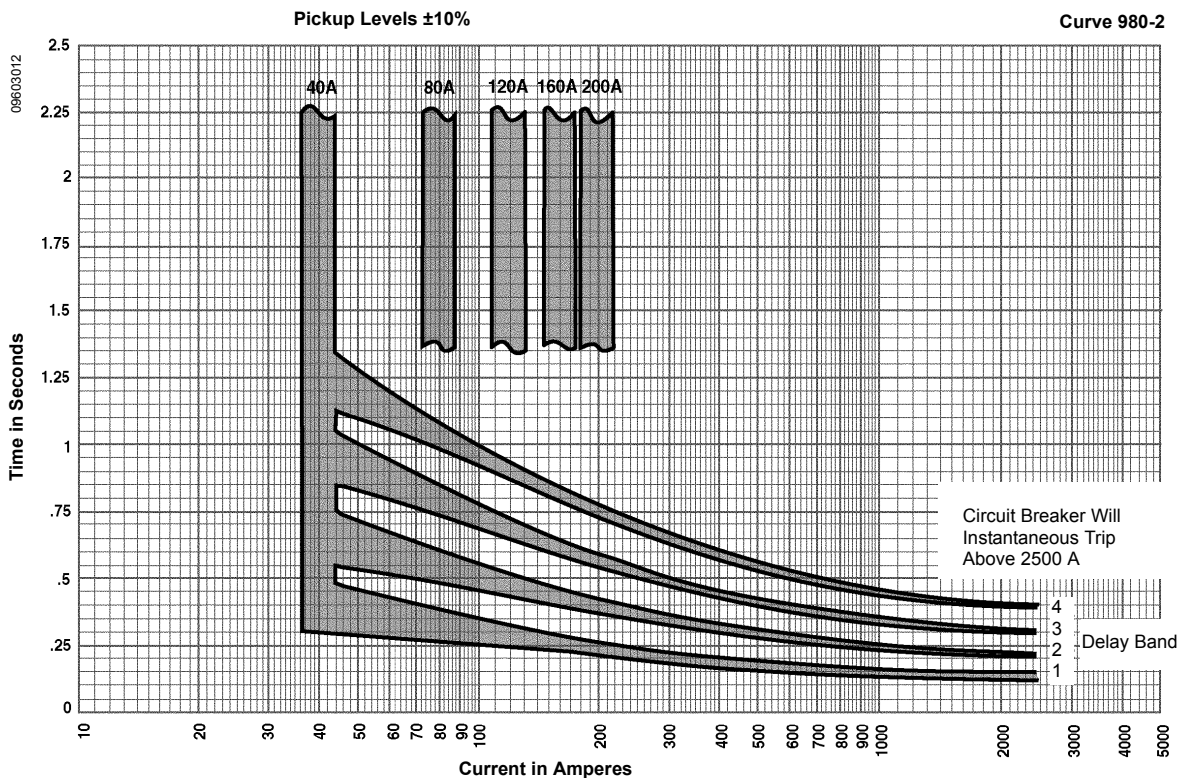

Figure 49: Ground Fault Module GFM250JD Trip Curve



PowerPact® H- and J-Frame Circuit Breakers

Section 6—Trip Curves

Figure 50: Earth Leakage Module Trip Curve

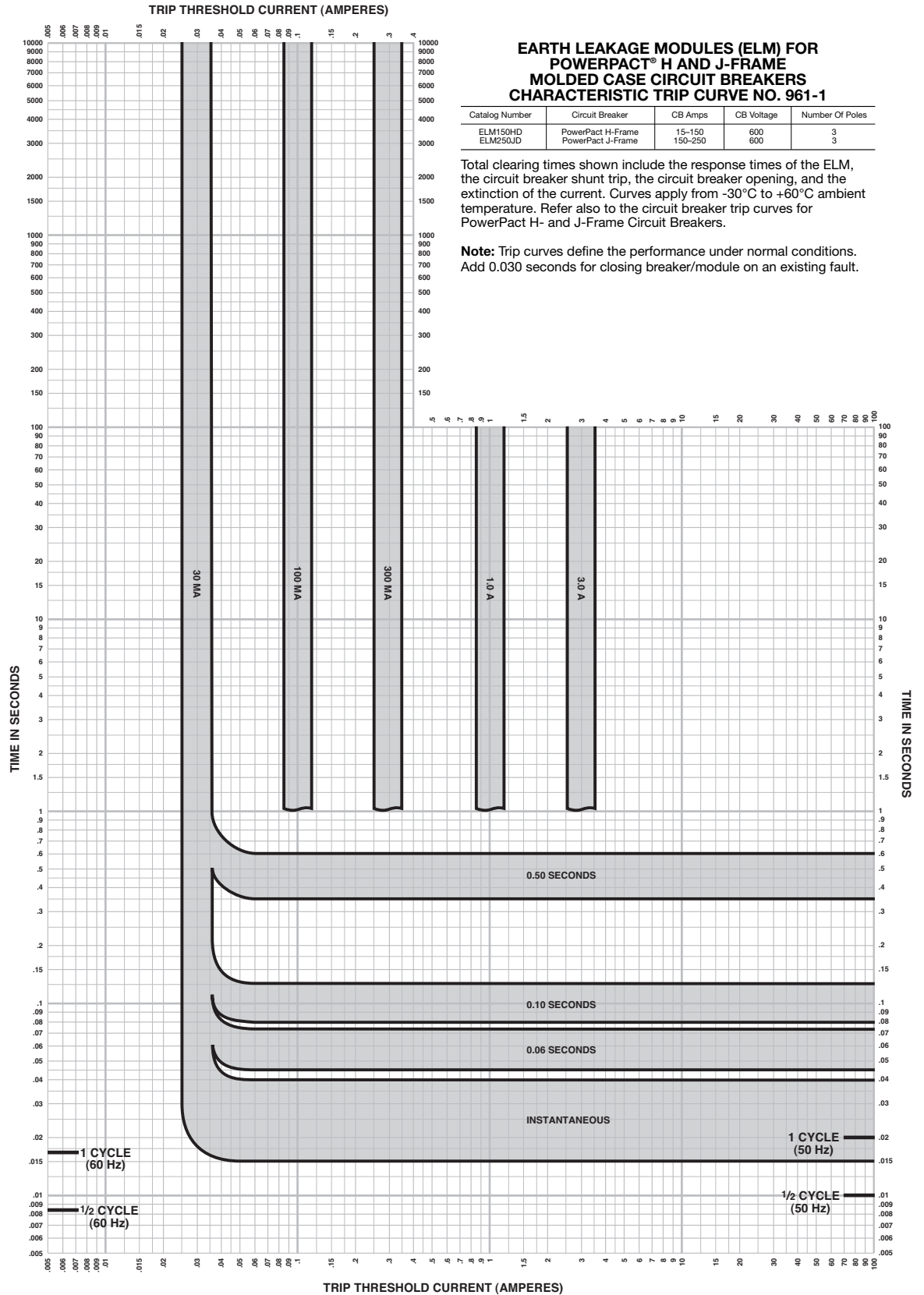

Section 7—MCP Instantaneous Trip Points

Table 63: M71 Instantaneous Trip Points

		Automatic Setting (A)		Manual Adjustment (A)							
I_m Setting		1	2	6x	8x	9x	10x	11x	12x	13x	
Motor Type	NEMA	A, B, C, D	B, E	(FLA) x (I_m)							
	IEC	N	H								
FLA	1.5	12	16.5	9	12	13.5	15	16.5	18	19.5	
	3	24	33	18	24	27	30	33	36	39	
	6	48	66	36	48	54	60	66	72	78	
	8	64	88	48	64	72	80	88	96	104	
	11	88	121	66	88	99	110	121	132	143	
	14	112	154	84	112	126	140	154	168	182	
	17	136	187	102	136	153	170	187	204	221	
	20	160	220	120	160	180	200	220	240	260	
	25	200	275	150	200	225	250	275	300	325	
Dampening for motor in-rush (% FLA)		1300%	1700%	1300%	—						

Table 64: M72 Instantaneous Trip Points

		Automatic Setting (A) ¹		Manual Adjustment (A) ¹							
I_m Setting		1	2	6x	8x	9x	10x	11x	12x	13x	
Motor Type	NEMA	A, B, C, D	B, E	(FLA) x (I_m)							
	IEC	N	H								
FLA	14	112	154	84	112	126	140	154	168	182	
	17	136	187	102	136	153	170	187	204	221	
	21	168	231	126	168	189	210	231	252	273	
	24	192	264	144	192	216	240	264	288	312	
	27	216	297	162	216	243	270	297	324	351	
	29	232	319	174	232	261	290	319	348	377	
	32	256	352	192	256	288	320	352	384	416	
	36	288	396	216	288	324	360	396	432	468	
	42	336	462	252	336	378	420	462	504	546	
Dampening for motor in-rush (% FLA)		1300%	1700%	1300%	—						

¹ ± 5% of nominal amperage shown above

PowerPact® H- and J-Frame Circuit Breakers
Section 7—MCP Instantaneous Trip Points

Table 65: M73 Instantaneous Trip Points

		Automatic Setting (A) ¹		Manual Adjustment (A) ¹							
I _m Setting		1	2	6x	8x	9x	10x	11x	12x	13x	
Motor Type	NEMA	A, B, C, D	B, E	(FLA) x (I _m)							
	IEC	N	H								
FLA	30	240	330	180	240	270	300	330	360	390	
	35	280	385	210	280	315	350	385	420	455	
	41	328	451	246	328	369	410	451	492	533	
	46	368	506	276	368	414	460	506	552	598	
	51	408	561	306	408	459	510	561	612	663	
	56	448	616	336	448	504	560	616	672	728	
	63	504	693	378	504	567	630	693	756	819	
	71	568	781	426	568	639	710	781	852	923	
	80	640	880	480	640	720	800	880	960	1040	
Dampening for motor in-rush (% FLA)		1300%	1700%	1300%	—						

¹ ± 5% of nominal amperage shown above

Table 66: M74 Instantaneous Trip Points

		Automatic Setting (A) ¹		Manual Adjustment (A) ¹							
I _m Setting		1	2	6x	8x	9x	10x	11x	12x	13x	
Motor Type	NEMA	A, B, C, D	B, E	(FLA) x (I _m)							
	IEC	N	H								
FLA	58	464	638	348	464	522	580	638	696	754	
	71	568	781	426	568	639	710	781	852	923	
	79	632	869	474	632	711	790	869	948	1027	
	86	688	946	516	688	774	860	946	1032	1118	
	91	728	1001	546	728	819	910	1001	1092	1183	
	97	776	1067	582	776	873	970	1067	1164	1261	
	110	880	1210	660	880	990	1100	1210	1320	1430	
	119	952	1309	714	952	1071	1190	1309	1428	1547	
	130	1040	1430	780	1040	1170	1300	1430	1560	1690	
Dampening for motor in-rush (% FLA)		1300%	1700%	1300%	—						

¹ ± 5% of nominal amperage shown above

Table 67: M75 Instantaneous Trip Points

		Automatic Setting (A) ¹		Manual Adjustment (A) ¹							
I _m Setting		1	2	6x	8x	9x	10x	11x	12x	13x	
Motor Type	NEMA	A, B, C, D	B, E	(FLA) x (I _m)							
	IEC	N	H								
FLA	114	912	1254	684	912	1026	1140	1254	1368	1482	
	137	1096	1507	822	1096	1233	1370	1507	1644	1781	
	145	1160	1595	870	1160	1305	1450	1595	1740	1885	
	155	1240	1705	930	1240	1395	1550	1705	1860	2015	
	163	1304	1793	978	1304	1467	1630	1793	1956	2119	
	172	1376	1892	1032	1376	1548	1720	1892	2064	2236	
	181	1448	1991	1086	1448	1629	1810	1991	2172	2353	
	210	1680	2310	1260	1680	1890	2100	2310	2500 ²	2500 ²	
	217	1736	2387	1302	1736	1953	2170	2387	2500 ²	2500 ²	
Dampening for motor in-rush (% FLA)		1100–1300%	1100–1700%	1100–1300%	—						

¹ ± 5% of nominal amperage shown above

² 2500 A maximum instantaneous trip point

PowerPact® H- and J-Frame Circuit Breakers
Section 7—MCP Instantaneous Trip Points



INDEX

A

accessories
 auxiliary switches 35
 locations of internal 34
 maximum combinations of 34
 motor operator 36
 accessory connections 34
 accessory suffix codes 8, 36, 39
 AIR **See** *ampere interrupting rating*
 altitude. **See** *operating conditions*
 ampere interrupting rating 5
 automatic protection settings 21
 auxiliary switches 35

B

bus-bar connections 28

C

cable operating handle 41
 catalog numbering 8
 chassis, drawout circuit breaker 33
 codes and standards
 H- and J-frame circuit breakers 10
 H- and J-frame switches 10
 connections. **See** *mounting and connections*
 connector
 MN/UVR 45
 MX/SHT 45
 OF/AX 45
 SD/AL 45

D

dimensional drawings
 H-frame 47
 J-frame 51, 53–55
 DIN rail mounting bracket 26
 drawout circuit breakers
 chassis functions 33
 mounting 33

E

endurance operations 13

F

features and benefits 24
 common design envelope 5
 dual-break rotating contacts 6
 high interrupting ratings (AIR) 5
 reduced let-through currents 6
 field installable accessories 7
 full load amp settings 21

H

handle position indication 6
 H-frame dimensional drawings 47

I

I-Line® circuit breakers 31
 installation
 plug-in circuit breakers 32
 interlocking 44

internal accessories 34
 interrupting rating 11

J

J-frame dimensional drawings 51, 53–55

L

locking systems 43
 locks
 direct rotary handle 43
 extended rotary operating handle 43
 motor operator 43
 toggle 43
 lugs
 voltage takeoff for mechanical 28

M

manual protection settings 21
 maximum accessory combinations 34
 MCP **See** *motor circuit protector*
 molded case switches 24
 motor circuit protector 20
 automatic protection settings 21
 full load amp settings 21
 motor circuit selector
 selection 23
 motor operator 36
 mounting and connections 26
 drawout circuit breakers 33
 I-Line® circuit breakers 31
 plug-in circuit breakers 32
 unit-mount circuit breakers 26
 MX shunt trip 45

N

numbering, catalog 8

O

open/closed position switch 45
 operating conditions 24
 altitude 13
 temperature 13
 vibration 13
 operating handle
 cable operating mechanism 41
 operating handles
 direct mounted rotary 40
 door mounted rotary 40–41
 operating mechanism 6
 operations, endurance 13

P

plug-in circuit breakers
 mounting 32
 parts of configuration 32
 safety trip interlock 32
 positive contact indication 11

R

ratings
 circuit breaker interrupting 11
 corner grounded delta 13
 UL 489 11
 re-rating

PowerPact® H- and J-Frame Circuit Breakers

Index

altitude 13
rotary operating handles 39
 directly mounted 40
 door mounted 40–41

S

safety trip interlock 32
shunt trip (MX) 35–36, 45
special ratings 10
specifications 24
 molded case switches 24
suffix codes 8, 36, 39
switch
 alarm 35
 auxiliary 35
 changeover 35
 electrical characteristics
 MX/MN 36
 OF, SD and SDE 35
 MN undervoltage trip switch 36
 MX shunt trip 36
switches
 OF auxiliary switch 45
switches, automatic molded case 24

T

temperature **See** *operating conditions*
trip curves 59, 70
trip units 9

U

UL 489 ratings 11
undervoltage trip 45
undervoltage trip (MN) 36
unit-mount circuit breakers 26
 bus-bar connections 28
 mounting 26

V

voltage takeoff for mechanical lugs 28

W

wire sizes for accessory connections 34

Schneider Electric USA

Street Address
City, State Zip Country
1-888-SquareD
(1-888-778-2733)
www.us.SquareD.com

Schneider Electric Canada

19 Waterman Avenue,
M4B 1 Y2
Toronto, Ontario
1-800-565-6699
www.schneider-electric.ca

0611CT0401R05/09 © 2004–2009 Schneider Electric All Rights Reserved
Replaces 0611CT0401R8/07

05/2009

X-ON Electronics

Largest Supplier of Electrical and Electronic Components

Click to view similar products for [Schneider manufacturer](#):

Other Similar products are found below :

[HMIGTO2310](#) [GS1AE21](#) [METSEPM8240](#) [LC1DT25B7](#) [LU9M1](#) [7D](#) [7S](#) [7XA1](#) [8501RS44V24](#) [8501RSD14P14V51](#) [8501XM4](#)
[8501XO20V03Y414](#) [9001KXRK](#) [9001SKR9P35RH25](#) [9001SKT35L31](#) [9003K2C003GA](#) [9007AA1](#) [9007BA1](#) [9007C54D](#) [9007C62A2](#)
[9007C68T5](#) [9007CA11](#) [9007FA3](#) [9007HA4](#) [9007HA6](#) [9007KA1](#) [9007KB11](#) [9007MS01S0206](#) [9007MS10S0100](#) [9012GAR4](#) [9012GAW2](#)
[9012GBW1](#) [9012GDW5E3](#) [9012GFW1](#) [9012GNG1](#) [9012GNG3](#) [9012GNG6](#) [9013FHG39J69](#) [9013GHG2J30](#) [9050JCK2F30V14](#) [GZ1E02](#)
[A9F07125](#) [ATS01N222RT](#) [ATV12H018F1](#) [RSL1PRJU](#) [9001KA35](#) [9001KA3G](#) [9001KR1GH5](#) [9001KXSDC](#) [9007C52A2](#)