

Sandflex® means world-class know-how and quality.

Sandflex program of holesaws is the result of more than 25 years of purposeful research and development – an effort that has given us superior know-how in the field of metal cutting techniques. It is this unique know-how that gives Sandflex saws and sawblades an unchallenged leadership in the world marketplace. Quality, performance and availability are the key words in our entire operation. This is why we design our products in close cooperation with customers and users all over the world, continuously taking note of their views and expressed needs and using them in our development work.

To us, quality is a concept that goes far beyond just product development. This reflects in our extensive effort to give our customers the best support there is. Making the end users everyday work a bit easier by providing practical advice and information is an important part of that effort. The new Sandflex packaging system is the most recent example of that.



The right saw and arbor combination in a flash.

The new Sandflex packaging system makes finding and combining the right saw and the right arbor an easy task.

Dimensions and information on suitable arbors for various types of jobs are also given on each individual package. Each package is also marked with its EAN-code, to facilitate handling of your stock.

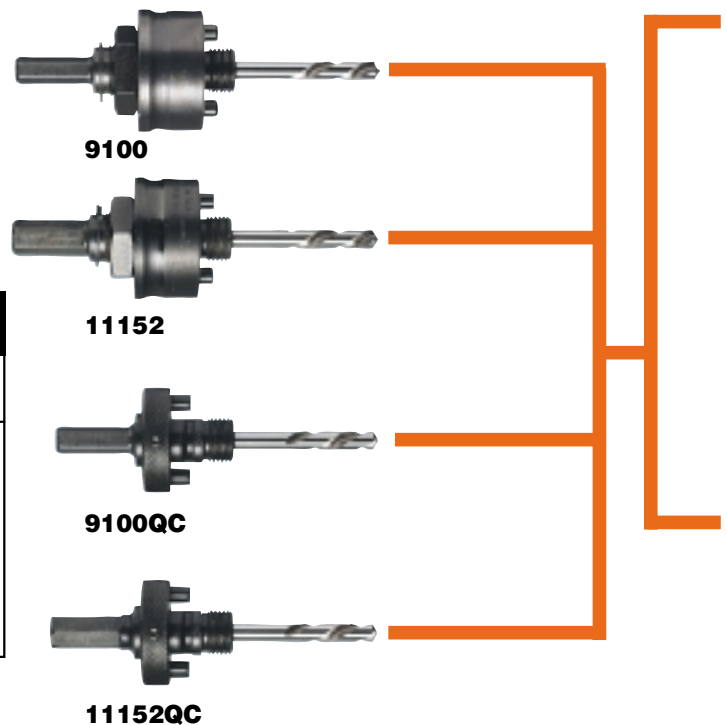
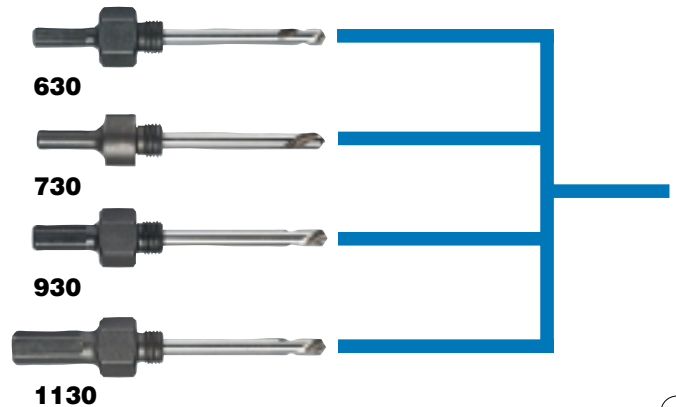

Arbors		
Product code	EAN-code 731151+	Dim. \blacklozenge \blacktriangle mm / inch
3834-ARBR-630-C	8228576	6,4 1/4 \blacklozenge
3834-ARBR-730-C	8225674	7,0 9/32 \blacktriangle
3834-ARBR-930-C	8225681	8,5 11/32 \blacklozenge
3834-ARBR-1130-C	8228583	11,1 7/16 \blacklozenge
3834-ARBR-9100-C	8228590	8,5 11/32 \blacklozenge
3834-ARBR-11152-C	8225698	11,1 7/16 \blacklozenge
3834-ARBR-9100QC-C	8225704	8,5 11/32 \blacklozenge
3834-ARBR-11152QC-C	8225711	11,1 7/16 \blacklozenge

For accessories and complete assortment, please refer to our main catalog.

The new Sandflex® – a complete family of high-performance holesaws.

For many years now, Sandflex holesaws have been the standard of comparison for precision, quality and flexibility of use. The new, orange version will carry this tradition further, in a complete family of saws and arbors that will each meet your most demanding requirements for performance and durability. The Sandflex family name is your guarantee for that.



Ø 14 – 30 mm
9/16 – 1 3/16 inch



Ø 32 – 76 mm
1 1/4 – 3 inch



Ø 79 – 152 mm
3 1/8 – 6 inch

Holesaws

Dim. mm /inch	Product-code	EAN-code 731151+
14 9/16	3830-14-C	8228347
16 5/8	3830-16-C	8225353
17 11/16	3830-17-C	8228354
19 3/4	3830-19-C	8225360
20 25/32	3830-20-C	8225377
21 13/16	3830-21-C	8228361
22 7/8	3830-22-C	8225384
24 15/16	3830-24-C	8228378
25 1	3830-25-C	8225391
27 1 1/16	3830-27-C	8225407
29 1 1/8	3830-29-C	8225414
30 1 3/16	3830-30-C	8225421
32 1 1/4	3830-32-C	8225438
33 1 5/16	3838-33-C	8228385
35 1 3/8	3830-35-C	8225445
37 1 7/16	3830-37-C	8228392
38 1 1/2	3830-38-C	8225452
40 1 9/16	3830-40-C	8228408
41 1 5/8	3830-41-C	8225469
43 1 11/16	3830-43-C	8228415
44 1 3/4	3830-44-C	8225476
46 1 13/16	3830-46-C	8228422
48 1 7/8	3830-48-C	8225483
51 2	3830-51-C	8225490
52 2 1/16	3830-52-C	8228439
54 2 1/8	3830-54-C	8225506
56 2 3/16	3830-56-C	8228446
57 2 1/4	3830-57-C	8225513
59 2 5/16	3830-59-C	8228453
60 2 3/8	3830-60-C	8225520
64 2 1/2	3830-64-C	8225537
65 2 9/16	3830-65-C	8228460
67 2 5/8	3830-67-C	8225544
68 2 11/16	3830-68-C	8228477
70 2 3/4	3830-70-C	8225551
73 2 7/8	3830-73-C	8228484
76 3	3830-76-C	8225568
79 3 1/8	3830-79-C	8228491
83 3 1/4	3830-83-C	8225575
86 3 3/8	3830-86-C	8228507
89 3 1/2	3830-89-C	8225582
92 3 5/8	3830-92-C	8225599
95 3 3/4	3830-95-C	8225605
98 3 7/8	3830-98-C	8228514
102 4	3830-102-C	8225612
105 4 1/8	3830-105-C	8225629
108 4 1/4	3830-108-C	8228521
111 4 3/8	3830-111-C	8228538
114 4 1/2	3830-114-C	8225636
121 4 3/4	3830-121-C	8225643
127 5	3830-127-C	8225650
133 5 1/4	3830-133-C	8228545
140 5 1/2	3830-140-C	8228552
146 5 3/4	3830-146-C	8228569
152 6	3830-152-C	8225667



BAHCO

Industrial holesaws

Power Driver PD Arbors stabilises the sawing operation and distributes efficiently the cutting forces on the saw.

Holesaws can be easily fitted or removed with the Arbor fixed in the power drill.



Hardened body for maximum strength

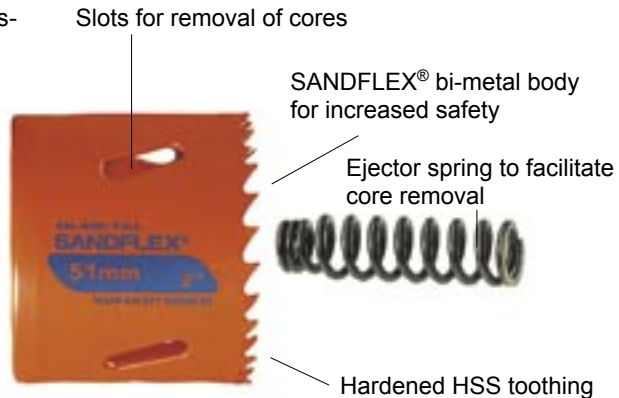

SANDFLEX® holesaws designed for metalcutting

Bahco's Sandflex® holesaws have a 4/6 tooth shape. By varying the distance between the teeth (vari-pitch) a smoother cut is achieved with less vibration, even in difficult-to-cut materials. The aggressive tooth shape cuts fast, whilst the large tooth gullets and large tooth set make swarf removal more efficient.

All VIP holesaws are manufactured from SANDFLEX® bi-metal steel with hardened teeth of high alloyed high-speed steel (HSS). Bi-metal gives increased safety as it will not shatter if overloaded. It enables the highest cutting performance in all machinable materials from wood to stainless steel, and it gives increased resistance to wear.

All Bahco's holesaws

- 38 mm (1 1/2") cutting depth.
- Solid, flat cap design to withstand heavy workload.
- All sizes are in millimetres.

The following are general points regarding the use of Bahco hole saws.

- Clamp the workpiece firmly.
- **Selection of arbor** - Select the proper arbor for the hole saw size and your power drill. If the arbor has drive pins, make sure they are engaged. For arbors with drive pins, slide pin ring back, screw hole saw onto arbor to shoulder, and push ring with pins into hole saw while backing off hole saw if necessary.
- Maintain positive feed rate, but exercise care not to abruptly feed saw into work. Always start operation perpendicular to the workpiece.
- **Removal of chips** - is extremely important. Intermittent withdrawal of holesaw is recommended to prevent clogging in the gullet area.
- **Operation speeds (RPM)** - The cutting speeds recommended in the table are intended as a general guide. Your experience may show that the variations from these general recommendations ensure better performance.

- Always use a lubricant when sawing in metal. It gives better performance and prolongs the life of the holesaw.
- A water coolant may be helpful when cutting ceramic tile. Plenty of water may be required.
- Use an arbor with a carbide tipped pilot drill when cutting ceramic tile, firebrick and other abrasive materials.
- When cutting fibreglass, glass reinforced plastics, bakelite and similar materials, reduce speed so that materials do not soften or clog the gullets of the saw.

Carbide tipped holesaws for cutting in hard, abrasive materials

On our new carbide tipped holesaws the tooth tips consist of a carbide "round rod" which is fusion welded to the back material. The tip is then ground to its final shape with 5 degrees positive cutting angle.

CT holesaws open new possibilities to cut holes in materials such as light concrete, brick, tile, reinforced plastics and other abrasive non-ferrous materials.



Carbide tipped hole saws are **not** recommended for cutting ferrous materials (steel).



When sawing in thick and difficult-to-cut materials, it may help to drill a few holes in the periphery of the circle, which greatly facilitates swarf removal.

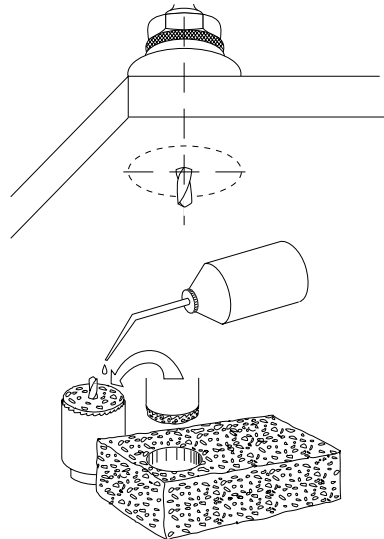
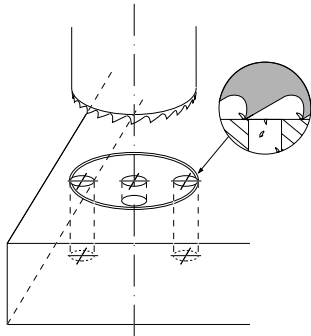

When sawing in wood finish off the sawing operation from the reverse side to avoid splinters.

Place an oil-imbibed sponge in the hole-saw if you

- cannot lubricate normally.
- are sawing in stainless steel.
- are sawing in a difficult-to-reach position (e.g. from underneath the material)

You may use your holesaw to manufacture your own sponge. Saw into a normal car sponge without using the pilot drill. Engage this afterwards.

Operating speeds VIP holesaws

Size MM	Size INCH	Mild steel	Cast iron	Tool and stainless steel	Brass	Aluminum	Wood
14	9/16	580	400	300	790	900	3000
16	5/8	550	365	275	730	825	3000
17	11/16	500	330	250	665	750	3000
19	3/4	460	300	230	600	690	3000
20	25/32	440	290	220	580	660	3000
21	13/16	425	280	210	560	635	3000
22	7/8	390	260	195	520	585	3000
24	15/16	370	245	185	495	555	3000
25	1	350	235	175	470	525	2700
27	1 1/16	325	215	160	435	480	2700
29	1 1/8	300	200	150	400	450	2700
30	1 3/16	285	190	145	380	425	2400
32	1 1/4	275	180	140	380	410	2400
33	1 5/16	260	175	135	345	390	2400
35	1 3/8	250	165	125	330	375	2400
37	1 7/16	240	160	120	315	360	2400
38	1 1/2	230	150	115	300	345	2400
40	1 9/16	220	145	110	290	330	2100
41	1 5/8	210	140	105	280	315	2100
43	1 11/16	205	135	100	270	305	2100
44	1	195	130	95	260	295	2100
46	1 13/16	190	125	95	259	285	2100
48	1 7/8	180	120	90	240	270	2100
51	2	170	115	85	230	255	2000
52	2 1/16	165	110	80	220	245	2000
54	2 1/8	160	105	80	210	240	2000
56	2 7/32	150	100	75	200	225	2000
57	2	150	100	75	200	225	2000
59	2 5/16	145	100	75	195	225	2000
60	2 3/8	140	95	70	190	220	2000
64	2 1/2	135	90	65	180	205	1800
65	2 9/16	130	85	65	175	200	1800
67	2 5/8	130	85	65	170	195	1800
68	2 11/16	130	85	65	170	195	1800
70	2	125	80	60	160	185	1800
73	2 7/8	120	80	60	160	180	1800
76	3	115	75	55	150	170	1800
79	3 1/8	110	70	55	140	165	1500
83	3	105	70	50	140	155	1500
86	3 3/8	100	65	50	130	150	1500
89	3 1/2	95	65	45	130	145	1200
92	3 5/8	95	60	45	120	140	1200
95	3	90	60	45	120	135	1200
98	3 7/8	90	60	45	120	135	1200
102	4	85	55	40	110	130	1000
105	4 1/8	80	55	40	110	120	1000
108	4	80	55	40	110	120	900
111	4 3/8	80	50	40	100	120	900
114	4 1/2	75	50	35	100	105	900
121	4	75	50	35	95	95	900
127	5	65	45	30	90	90	800
133	5	60	40	25	85	85	800
140	5 1/2	60	40	25	85	85	800
146	5	55	35	25	75	75	800
152	6	55	35	25	75	75	800
168	6 5/8	50	35	25	65	75	700
177	7	45	35	25	65	75	700
210	8 1/4	40	25	20	55	60	500

Operating speeds CT holesaws

Size MM	Size INCH	Fire brick Ceramic tile	Soft brick Slate	Ply-wood	Fibre glass	Bake-lite	Hard Wood
14	9/16	680	1705	3400	2380	1030	1360
16	5/8	610	1535	3060	2140	930	1220
17	11/16	560	1395	2785	1950	850	1110
19	3/4	510	1280	2550	1790	770	1020
20	25/32	480	1210	2430	1700	730	970
21	13/16	470	1180	2355	1650	710	940
22	7/8	430	1095	2180	1530	660	870
24	15/16	410	1020	2040	1430	620	810
25	1	380	960	1920	1340	580	760
27	1 1/16	360	900	1800	1260	550	720
29	1 1/8	340	850	1700	1190	510	680
30	1 3/16	320	810	1610	1130	490	640
32	1 1/4	310	770	1530	1070	460	610
33	1 5/16	290	730	1460	1020	440	580
35	1 3/8	280	700	1390	980	420	550
37	1 7/16	270	670	1330	930	400	530
38	1 1/2	260	640	1280	890	390	510
40	1 9/16	240	615	1220	860	370	490
41	1 5/8	235	590	1180	820	360	470
43	1 11/16	230	570	1130	790	340	450
44	1	220	550	1100	770	330	430
46	1 13/16	210	530	1060	740	320	420
48	1 7/8	205	510	1020	710	310	410
51	2	190	480	960	670	290	380
52	2 1/16	185	465	930	650	280	370
54	2 1/8	180	450	900	630	270	360
56	2 7/32	175	435	870	610	265	345
57	2	170	430	850	600	260	340
59	2 5/16	165	415	830	580	250	330
60	2 3/8	160	405	810	560	240	320
64	2 1/2	150	380	760	540	230	310
65	2 9/16	148	370	750	530	225	300
67	2 5/8	145	365	730	510	220	290
68	2 11/16	142	360	720	500	215	285
70	2	140	350	700	490	210	280
73	2 7/8	135	330	670	470	200	270
76	3	130	320	640	450	190	260
79	3 1/8	125	310	610	430	185	250
83	3	120	295	590	410	180	240
86	3 3/8	115	285	570	400	170	230
89	3 1/2	110	270	550	380	165	220
92	3 5/8	105	260	530	370	160	210
95	3	100	255	510	360	155	200
98	3 7/8	98	250	490	350	150	195
102	4	95	240	480	330	145	190
105	4 1/8	92	235	460	320	140	185
108	4	90	230	450	310	135	180
111	4 3/8	87	220	440	300	130	175
114	4 1/2	85	210	420	290	128	170
121	4	80	200	400	280	120	160
127	5	75	190	380	270	110	150
133	5	72	180	365	255	105	145
140	5 1/2	70	170	350	240	100	140
146	5	67	165	335	230	95	135
152	6	65	160	320	220	90	130

X-ON Electronics

Largest Supplier of Electrical and Electronic Components

Click to view similar products for [bahco manufacturer](#):

Other Similar products are found below :

[65I/7-1](#) [B219.005](#) [BE-7855](#) [BE-9675](#) [BE-9882I](#) [BE-9882S](#) [1RM-11](#) [KSR753-1P](#) [1931M/10T](#) [2101S-180](#) [3834-SET-95](#) [111M/11T](#)
[65I/T20-2P](#) [LINDSTROM SUPREME MODULE](#) [9073P](#) [1952M/17T](#) [1936M-16-17](#) [222D](#) [6M/S8](#) [6962L](#) [111M-15](#) [8074 IP](#) [8075 IP](#) [L7892](#)
[28M-10](#) [2928-200](#) [3906-300-24-100](#) [21HDG-200](#) [2223 D-150](#) [3417 NF](#) [3417NFB](#) [3417 NF VDE](#) [3419 B](#) [3736S/6](#) [3875-LY5](#) [3875-LY7](#)
[4532-AL](#) [4532-B](#) [4532-BL](#) [4532-C](#) [480-20](#) [BE-8870](#) [CR W 03](#) [NS006-1011](#) [NS006-1213](#) [NS006-1214](#) [NS006-1617](#) [NS006-1819](#) [NS006-1920](#) [TAH2628G-160](#)