

## Up to Category 2, EN 954-1 PNOZ X7



### Unit features

- ▶ Positive-guided relay outputs:
  - 2 safety contacts (N/O), instantaneous
- ▶ Connection options for:
  - E-STOP pushbutton
  - Reset button
- ▶ LED indicator for:
  - Switch status channel 1/2
  - Supply voltage
- ▶ See order reference for unit types



### Safety features

The relay conforms to the following safety criteria:

- ▶ The circuit is redundant with built-in self-monitoring.
- ▶ The safety function remains effective in the case of a component failure.
- ▶ The correct opening and closing of the safety function relays is tested automatically in each on-off cycle.

Safety relay for monitoring E-STOP pushbuttons.

### Approvals

	PNOZ X7
	◆
	◆

### Unit description

The safety relay meets the requirements of EN 60204-1 and IEC 60204-1 and may be used in applications with

- ▶ E-STOP pushbuttons

The safety relay is not suitable for non-contact barriers because

- ▶ a dynamic start is not possible
- ▶ the unit can be started during the delay-on de-energisation time.

### Block diagram

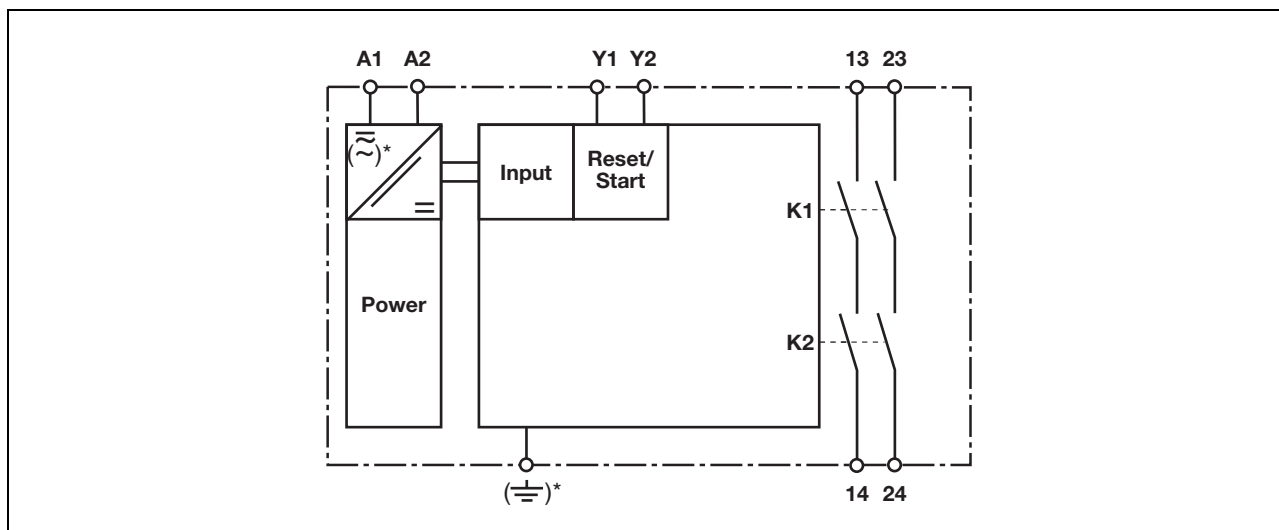

\*Only when  $U_B = 42 - 240 \text{ VAC}$

Galvanic isolation only when  $U_B = 42 - 240 \text{ VAC}$

## Up to Category 2, EN 954-1 PNOZ X7

### Function description

- ▶ Single-channel operation: no redundancy in the input circuit, earth faults in the reset and input circuit are detected.
- ▶ Automatic start: Unit is active once the input circuit has been closed.
- ▶ Manual reset: Unit is active once the input circuit is closed and then the reset circuit is closed.
- ▶ Increase in the number of available contacts by connecting contact expander modules or external contactors/relays.

### Timing diagram

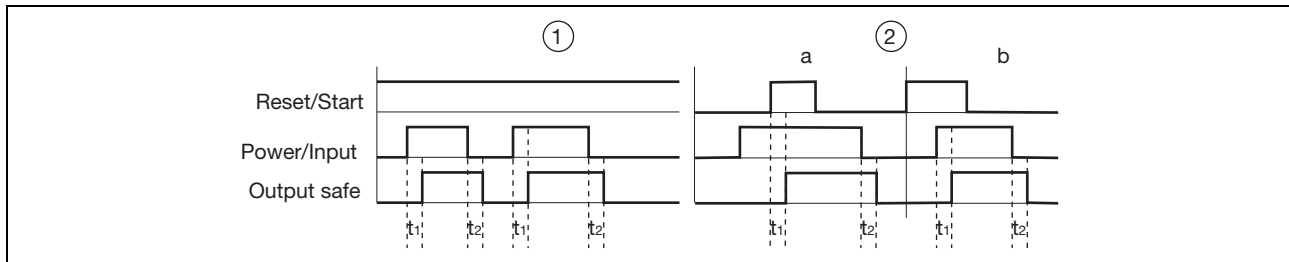

### Key

- ▶ Power: Supply voltage
- ▶ Reset/start: Reset circuit Y1-Y2
- ▶ Input: Input circuits A1
- ▶ Output safe: Safety contacts 13-14, 23-24
- ▶ ①: Automatic reset
- ▶ ②: Manual reset
- ▶ a: Input circuit closes before reset circuit
- ▶ b: Reset circuit closes before input circuit
- ▶ t<sub>1</sub>: Switch-on delay
- ▶ t<sub>2</sub>: Delay-on de-energisation

### Wiring

#### Please note:

- ▶ Information given in the “Technical details” must be followed.
- ▶ Outputs 13-14, 23-24 are safety contacts.
- ▶ To prevent contact welding, a fuse should be connected before the output contacts (see technical details).
- ▶ Calculation of the max. cable runs  $l_{max}$  in the input circuit:

$$l_{max} = \frac{R_{lmax}}{R_l / km}$$

$R_{lmax}$  = max. overall cable resistance (see technical details)  
 $R_l / km$  = cable resistance/km

- ▶ Use copper wire that can withstand 60/75 °C.
- ▶ Sufficient fuse protection must be provided on all output contacts with capacitive and inductive loads.

PNOZ X7 AC: The cable runs depend on the cable capacitance.

- ▶ Loop circuit, 1 phase: max.  $l_r = 1$  km
- ▶ Stub circuit: Cable capacitance  $C_L$  and therefore the cable runs  $l_s$  are dependent on the supply voltage  $U_B$

Cable capacitance  $C_L$  depends on the supply voltage  $U_B$

$U_B$ [V]	42	48	110	115	120	230	240
$C_L$ [nF]	37.5	37.5	37.5	37.5	37.5	7.5	7.5

	Loop circuit	Stub circuit
Cable runs		

## Up to Category 2, EN 954-1 PNOZ X7

### Preparing for operation

#### ► Supply voltage

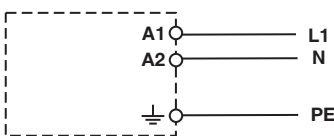
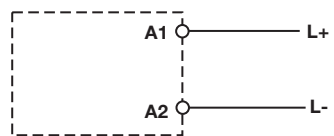
Supply voltage	AC	DC
		

#### ► Input circuit

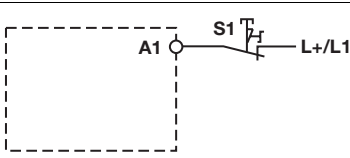
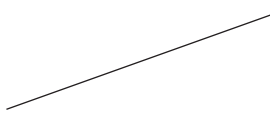
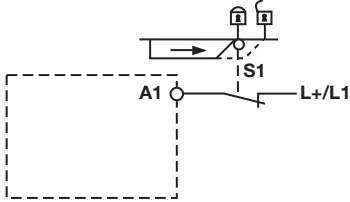
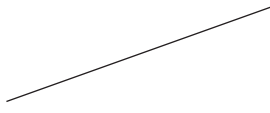
Input circuit	Single-channel	Dual-channel
E-STOP <b>without</b> detection of shorts across contacts		
Safety gate <b>without</b> detection of shorts across contacts		

#### ► Reset circuit

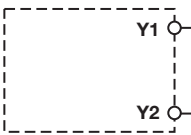
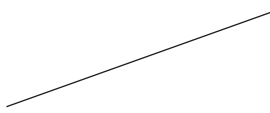
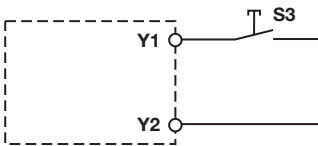
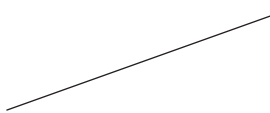

Reset circuit	E-STOP wiring (single-channel) Safety gate (single-channel)	E-STOP wiring (dual-channel) Safety gate (dual-channel)
Automatic reset		
Manual reset		

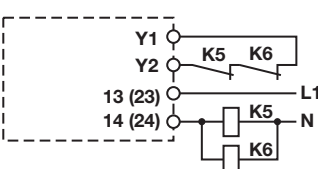
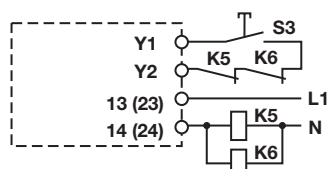
#### ► Feedback loop

Feedback loop	Automatic reset	Manual reset
Contacts from external contactors		

## Up to Category 2, EN 954-1 PNOZ X7

### ▶ Key

S1	E-STOP pushbutton
S3	Reset button
	Switch operated
	Gate open
	Gate closed

### Terminal configuration

$U_B = 24 \text{ VAC/DC}$

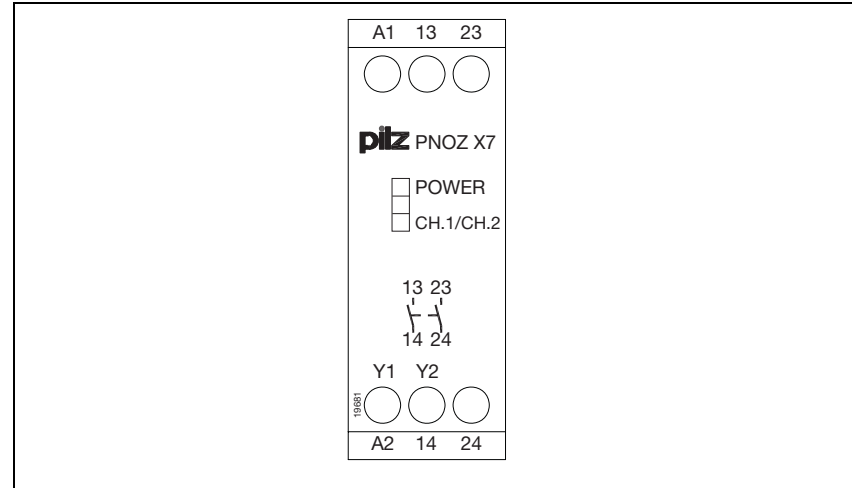

$U_B \text{ AC}$

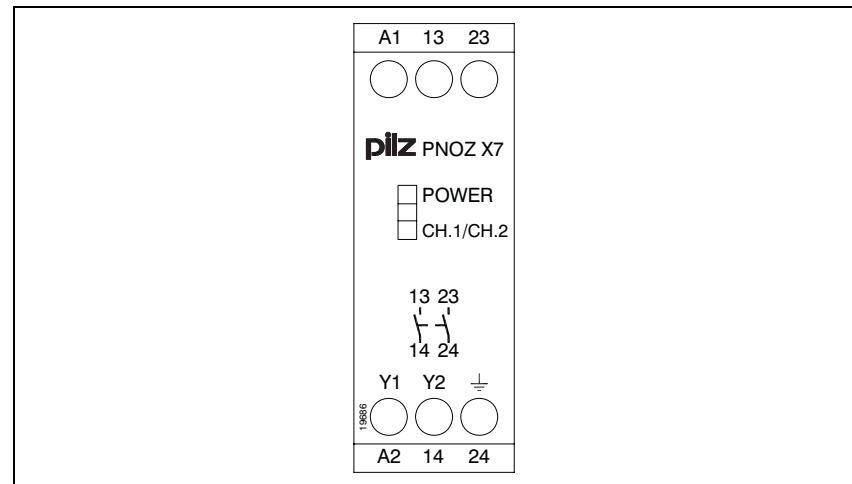

### Installation

- ▶ The safety relay should be installed in a control cabinet with a protection type of at least IP54.
- ▶ Use the notch on the rear of the unit to attach it to a DIN rail.
- ▶ Ensure the unit is mounted securely on a vertical DIN rail (35 mm) by using a fixing element (e.g. retaining bracket or an end angle).

### Dimensions

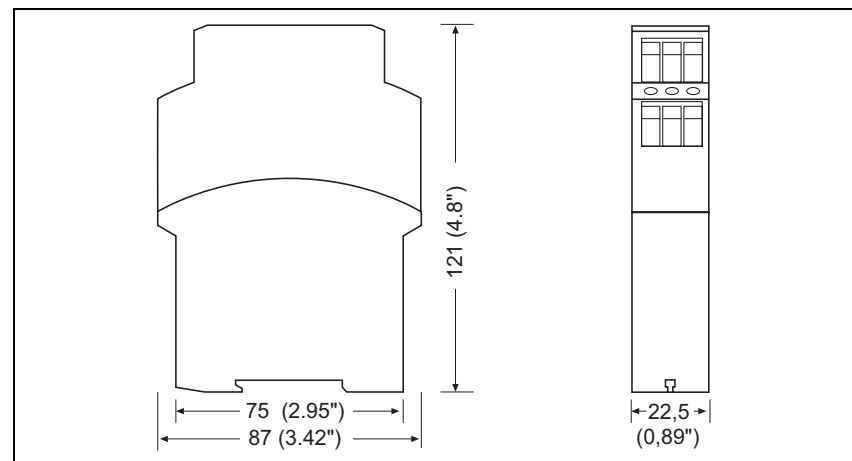

## Up to Category 2, EN 954-1 PNOZ X7

### Notice

This data sheet is only intended for use during configuration. For installation and operation, please refer to the operating instructions supplied with the unit.

### Service life graph

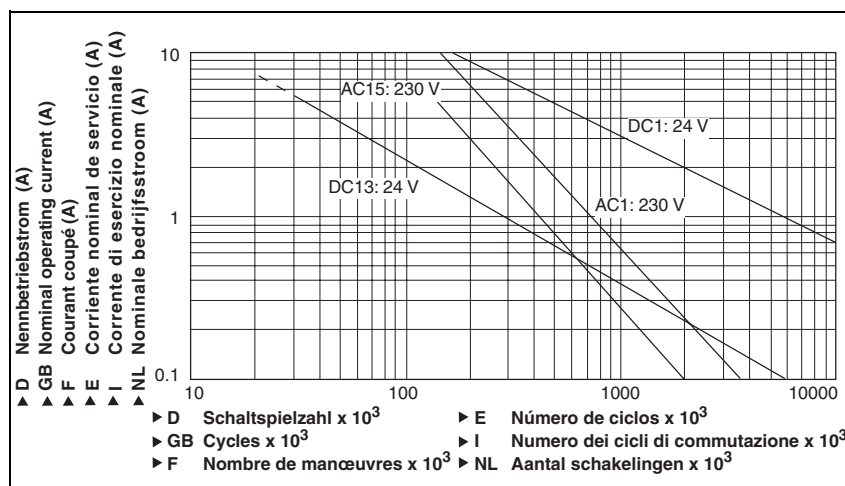

### Technical details

#### Electrical data

Supply voltage	
Supply voltage U <sub>B</sub> AC	<b>42 V, 48 V, 110 V, 115 V, 120 V, 230 V, 240 V</b>
Supply voltage U <sub>B</sub> AC/DC	<b>24 V</b>
Voltage tolerance	<b>-15 %/+10 %</b>
Power consumption at U <sub>B</sub> AC	<b>2.0 VA</b> Order no.: 774049, 774053, 774054, 774055, 774056, 774057, 774058 <b>3.0 VA</b> Order no.: 774059
Power consumption at U <sub>B</sub> DC	<b>1.5 W</b> Order no.: 774059
Frequency range AC	<b>50 - 60 Hz</b>
Residual ripple DC	<b>160 %</b>
Voltage and current at input circuit DC:	
<b>24.0 V</b>	<b>50.0 mA</b>
<b>42.0 V</b>	<b>49.0 mA</b>
<b>48.0 V</b>	<b>45.0 mA</b>
<b>110.0 V</b>	<b>14.0 mA</b>
<b>115.0 V</b>	<b>17.0 mA</b>
<b>120.0 V</b>	<b>16.0 mA</b>
<b>230.0 V</b>	<b>8.0 mA</b>
<b>240.0 V</b>	<b>7.0 mA</b>
reset circuit DC: <b>24.0 V</b>	<b>40.0 mA</b> Order no.: 774049, 774053, 774054, 774055, 774056, 774057, 774058 <b>210.0 mA</b> Order no.: 774059
feedback loop DC: <b>24.0 V</b>	<b>40.0 mA</b> Order no.: 774049, 774053, 774054, 774055, 774056, 774057, 774058 <b>210.0 mA</b> Order no.: 774059
Output contacts in accordance with <b>EN 954-1</b> Category 2	Safety contacts (N/O): <b>2</b>

## Up to Category 2, EN 954-1 PNOZ X7

### Electrical data

Utilisation category in accordance with <b>EN 60947-4-1</b>	$I_{\min}$ : <b>0.01 A</b> , $I_{\max}$ : <b>4.00 A</b> Order no.: 774049, 774053, 774054, 774055, 774056, 774057, 774058
Safety contacts: AC1 at <b>240 V</b>	<b>6.00 A</b> Order no.: 774059
	$P_{\max}$ : <b>1,000 VA</b> Order no.: 774049, 774053, 774054, 774055, 774056, 774057, 774058
	<b>1,500 VA</b> Order no.: 774059
Safety contacts: DC1 at <b>24 V</b>	$I_{\min}$ : <b>0.01 A</b> , $I_{\max}$ : <b>4.0 A</b> Order no.: 774049, 774053, 774054, 774055, 774056, 774057, 774058
	<b>6.0 A</b> Order no.: 774059
	$P_{\max}$ : <b>100 W</b> Order no.: 774049, 774053, 774054, 774055, 774056, 774057, 774058
	<b>150 W</b> Order no.: 774059
Utilisation category in accordance with <b>EN 60947-5-1</b>	
Safety contacts: AC15 at <b>230 V</b>	$I_{\max}$ : <b>4.0 A</b> Order no.: 774049, 774053, 774054, 774055, 774056, 774057, 774058
	<b>5.0 A</b> Order no.: 774059
Safety contacts: DC13 at <b>24 V</b> (6 cycles/min)	$I_{\max}$ : <b>4.0 A</b> Order no.: 774049, 774053, 774054, 774055, 774056, 774057, 774058
	<b>6.0 A</b> Order no.: 774059
Contact material	<b>AgSnO<sub>2</sub> + 0.2 µm Au</b>
External contact fuse protection to <b>EN 60947-5-1</b>	
Blow-out fuse, quick	
Safety contacts:	<b>4 A</b> Order no.: 774049, 774053, 774054, 774055, 774056, 774057, 774058
	<b>6 A</b> Order no.: 774059
Blow-out fuse, slow	
Safety contacts:	<b>4 A</b>
Circuit breaker 24 VAC/DC, characteristic B/C	
Safety contacts:	<b>4 A</b>
Max. overall cable resistance $R_{i\max}$ input circuits, reset circuits	
single-channel at $U_B$ DC	<b>15 Ohm</b> Order no.: 774059
single-channel at $U_B$ AC	<b>15 Ohm</b> Order no.: 774059
<b>Times</b>	
Switch-on delay	
with automatic reset typ.	<b>230 ms</b> Order no.: 774049, 774053, 774054, 774055, 774056, 774057, 774058
	<b>50 ms</b> Order no.: 774059
with automatic reset max.	<b>150 ms</b> Order no.: 774059
	<b>700 ms</b> Order no.: 774049, 774053, 774054, 774055, 774056, 774057, 774058
with automatic reset after power on typ.	<b>230 ms</b> Order no.: 774049, 774053, 774054, 774055, 774056, 774057, 774058
	<b>50 ms</b> Order no.: 774059
with automatic reset after power on max.	<b>150 ms</b> Order no.: 774059
	<b>700 ms</b> Order no.: 774049, 774053, 774054, 774055, 774056, 774057, 774058
with manual reset typ.	<b>140 ms</b> Order no.: 774049, 774053, 774054, 774055, 774056, 774057, 774058
	<b>35 ms</b> Order no.: 774059
with manual reset max.	<b>150 ms</b> Order no.: 774059
	<b>700 ms</b> Order no.: 774049, 774053, 774054, 774055, 774056, 774057, 774058

## Up to Category 2, EN 954-1 PNOZ X7

Times	
Delay-on de-energisation with E-STOP typ.	<b>45 ms</b> Order no.: 774059 <b>70 ms</b> Order no.: 774049, 774053, 774054, 774055, 774056, 774057, 774058
with E-STOP max.	<b>100 ms</b> Order no.: 774049, 774053, 774054, 774055, 774056, 774057, 774058
with power failure typ.	<b>70 ms</b> Order no.: 774059 <b>45 ms</b> Order no.: 774059 <b>70 ms</b> Order no.: 774049, 774053, 774054, 774055, 774056, 774057, 774058
with power failure max.	<b>100 ms</b> Order no.: 774049, 774053, 774054, 774055, 774056, 774057, 774058 <b>70 ms</b> Order no.: 774059
Recovery time at max. switching frequency 1/s after E-STOP	<b>120 ms</b> Order no.: 774049, 774053, 774054, 774055, 774056, 774057, 774058 <b>50 ms</b> Order no.: 774059
after power failure	<b>120 ms</b> Order no.: 774049, 774053, 774054, 774055, 774056, 774057, 774058 <b>150 ms</b> Order no.: 774059
Supply interruption before de-energisation	<b>20 ms</b>
Environmental data	
EMC	<b>EN 60947-5-1, EN 61000-6-2</b>
Vibration in accordance with <b>EN 60068-2-6</b>	
Frequency	<b>10 - 55 Hz</b>
Amplitude	<b>0.35 mm</b>
Climatic suitability	<b>EN 60068-2-78</b>
Airgap creepage	<b>EN 60947-1</b>
Ambient temperature	<b>-10 - 55 °C</b>
Storage temperature	<b>-40 - 85 °C</b>
Protection type	
Mounting (e.g. control cabinet)	<b>IP54</b>
Housing	<b>IP40</b>
Terminals	<b>IP20</b>
Mechanical data	
Housing material	
Housing	<b>PPO UL 94 V0</b>
Front	<b>ABS UL 94 V0</b>
Max. cross section of external conductors with screw terminals	
1 core flexible	<b>0.20 - 4.00 mm<sup>2</sup>, 24 - 10 AWG</b>
2 core, same cross section, flexible:	
with crimp connectors, without insulating sleeve	<b>0.20 - 2.50 mm<sup>2</sup>, 24 - 14 AWG</b>
without crimp connectors or with TWIN crimp connectors	<b>0.20 - 2.50 mm<sup>2</sup>, 24 - 14 AWG</b>
Torque setting with screw terminals	<b>0.60 Nm</b>
Dimensions	
Height	<b>87.0 mm</b>
Width	<b>22.5 mm</b>
Depth	<b>121.0 mm</b>
Weight	<b>190 g</b> Order no.: 774059 <b>225 g</b> Order no.: 774049, 774053, 774054, 774055, 774056, 774057, 774058

The standards current on **09/04** apply.

## Up to Category 2, EN 954-1 PNOZ X7

### Max. continuous current

Number of contacts  $I_{\max}$  (A) at  $U_B$  AC

1	<b>4.00 A</b> Order no.: 774049, 774053, 774054, 774055, 774056, 774057, 774058
2	<b>3.00 A</b> Order no.: 774049, 774053, 774054, 774055, 774056, 774057, 774058

### Order reference

Type	Features	Terminals	Order no.
PNOZ X7	42 VAC	Screw terminals	774 058
PNOZ X7	48 VAC	Screw terminals	774 049
PNOZ X7	110 VAC	Screw terminals	774 053
PNOZ X7	115 VAC	Screw terminals	774 054
PNOZ X7	120 VAC	Screw terminals	774 055
PNOZ X7	230 VAC	Screw terminals	774 056
PNOZ X7	240 VAC	Screw terminals	774 057
PNOZ X7	24 VAC/DC	Screw terminals	774 059



## X-ON Electronics

Largest Supplier of Electrical and Electronic Components

*Click to view similar products for [Safety Relays](#) category:*

*Click to view products by [Pilz](#) manufacturer:*

Other Similar products are found below :

[7-1618103-5](#) [1351-1X](#) [1618089-2](#) [C200HDA003](#) [C200HMR432](#) [C200HMR832](#) [C200HMR833](#) [20-050-36X](#) [C500OD415CN](#) [2-1618068-0](#)  
[25994](#) [9-1618103-2](#) [SP10-ETL01](#) [21-890](#) [3-1618060-0](#) [C200HNC112](#) [C200HOD214](#) [C500CN812N](#) [1100X](#) [1100-42X](#) [1-1618062-0](#) [7-](#)  
[1618103-6](#) [50.12.9.110.1000](#) [SP16DRD](#) [SP16DRA](#) [XPSAXE5120P](#) [XPSECPE5131P](#) [C500-CE243](#) [607.5111.020](#) [439390016](#) [607.5111.009](#)  
[607.5111.010](#) [PSR-MM25-1NO-2DO-24DC-SC](#) [NXSL5500](#) [600PSR-165/300-CU](#) [SR4D4110](#) [J73KN-AM-22](#) [G7SA-3A1B DC12](#) [G7SA-](#)  
[4A2B DC12](#) [G7SA-3A1B DC48](#) [G7SA-2A2B DC48](#) [ES-FA-9AA](#) [50.12.9.024.5000](#) [44510-2310](#) [V23047-A1036-A501](#) [44510-1081](#) [44510-](#)  
[2021](#) [44510-2232](#) [WUF-12-5060-T](#) [SR4M4021](#)