

### Features

- 160 MHz maximum frequency
- Low skew: 250ps
- Fast rise/fall time: 1.5ns
- Output Enable with tri-states
- Industrial Temperature
- 3.3V or 5V power supply
- Packaging (Pb-free & Green available):  
–8-pin SOIC (W)

### Applications

- 33 MHz for PCI
- 106.25 MHz for Fibre Channel
- 125 MHz for Ethernet
- 133 MHz for PCIX
- 155.52 MHz for OC3/SONET

### Logic Block Diagram

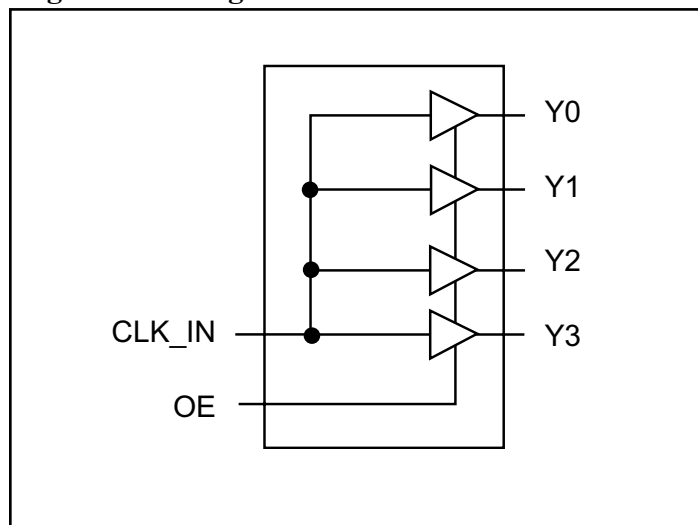

### Description

PI6C18551 is a low skew, low noise and high-speed clock buffer for computing, networking and communication applications. It is a non-inverting buffer with four outputs from a single input. The outputs are controlled by output enable pin (OE), outputs are tri-states when OE is LOW, and outputs are enabled when OE is HIGH.

### Pin Description

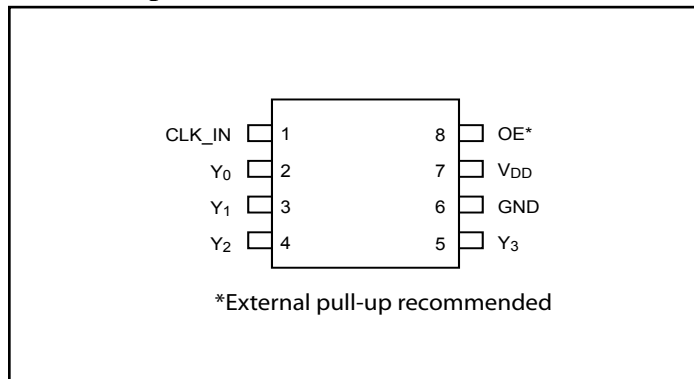

### Function Table

Inputs		Outputs
CLK_IN	OE	Y[3:0]
X	L	Z
L	H	L
H	H	H

#### Note:

1. X = Don't Care; Z = Tri-state

**Pin Description**

Pin Name	Type	Pin No	Descriptions
CLK_IN	Input	1	Input clock with pull-up resistor
Y0	Output	2	Output clock
Y1	Output	3	Output clock
Y2	Output	4	Output clock
Y3	Output	5	Output clock
GND	Ground	6	GROUND
V <sub>DD</sub>	Power	7	3.3V or 5V power supply
OE	Input	8	Output Enable with pull-up resistor. External pull-up resistor is recommended.

**External Components**

A minimum number of external components are required for proper operation. A decoupling capacitor of 0.01 $\mu$ F should be connected between V<sub>DD</sub> on pin 7 and GND on pin 6, as close to the device as possible. A 33-Ohm series terminating resistor may be used on each clock output if the trace is longer than 1 inch. An external 100k-Ohm pull-up resistor should be used on pin 8, OE.

**Absolute Maximum Ratings** (Over operating free-air temperature range)

Symbol	Parameters	Min.	Max.	Units
V <sub>DD</sub>	Supply Voltage		7	V
V <sub>I</sub>	Input Voltage	-0.5	V <sub>DD</sub> +0.5	
V <sub>O</sub>	Output Voltage	-0.5	V <sub>DD</sub> +0.5	
T <sub>s</sub>	Storage Temperature	-65	150	°C
T <sub>a</sub>	Ambient Temperature	-40	85	
T <sub>so</sub>	Soldering Temperature		260	

**DC Electrical Characteristics** ( $V_{DD} = 3.3V \pm 5\%$ ,  $T_A = -40$  to  $85^\circ C$ )

Symbol	Parameters	Condition	Min.	Typ.	Max.	Units
$V_{DD}$	3.3V I/O Supply Voltage		3.135		3.465	V
$V_{IH}$	Input High Voltage	CLK_IN, Note 1	$V_{DD}/2 + 0.7$		3.8	
		OE	2		$V_{DD}$	
$V_{IL}$	Input Low Voltage	CLK_IN, Note 1			$V_{DD}/2 - 0.7$	
		OE			0.8	
$V_{OH}$	Output High Voltage	$I_{OH} = -12mA$	2.4			
$V_{OL}$	Output Low Voltage	$I_{OL} = 12mA$			0.4	
$I_{DD}$	Power Supply Current	No load at 135 MHz		34		mA
$Z_O$	Output Impedance			20		Ohm
$R_{PU}$	Internal Pull-up Resistor	CLK_IN & OE		192		k-Ohm
$I_{OS}$	Short Circuit Current			-46		mA

**Notes:**

- Nominal switching threshold is  $V_{DD}/2$

**DC Electrical Characteristics** ( $V_{DD} = 5V \pm 5\%$ ,  $T_A = -40$  to  $85^\circ C$ )

Symbol	Parameters	Condition	Min.	Typ.	Max.	Units
$V_{DD}$	5V I/O Supply Voltage		4.75		5.25	V
$V_{IH}$	Input High Voltage	CLK_IN, Note 1	$V_{DD}/2 + 1$		5.5	
		OE	2		$V_{DD}$	
$V_{IL}$	Input Low Voltage	CLK_IN, Note 1			$V_{DD}/2 - 1$	
		OE			0.8	
$V_{OL}$	Output Low Voltage	$I_{OL} = 12mA$			0.4	
$V_{OH}$	Output High Voltage (CMOS Level)	$I_{OH} = -12mA$	4			
$I_{DD}$	Power Supply Current	No load at 135MHz		61		mA
$Z_O$	Output Impedance			20		Ohm
$R_{PU}$	Internal Pull-up Resistor	CLK_IN & OE		193		k-Ohm
$I_{OS}$	Short Circuit Current			-90		mA

**Notes:**

- Nominal switching threshold is  $V_{DD}/2$

**AC Electrical Characteristics** ( $V_{DD} = 3.3 \pm 5\%$ ,  $T_A = -40$  to  $85^\circ C$ )

Symbol	Parameters	Condition	Min.	Typ.	Max.	Units
$F_{in}$	Input Frequency		0		160	MHz
$F_o$	Output Frequency	3.3V, 15pF load <sup>(5)</sup>			160	
$F_o$	Output Frequency	5V, 15pF load <sup>(5)</sup>			135	
$T_R$	Rise Time	0.8V to 2.0V			1.5	ns
$T_F$	Fall Time	2.0V to 0.8V			1.5	
$T_{PD}$	Propagation Delay	3.3V, 135MHz <sup>(2)</sup>	2	4	8	
$T_{PD}$	Propagation Delay	5V, 135MHz <sup>(2)</sup>	1.5	3	6	
$T_{SK}$	Output Skew	$V_{DD}/2^{(3)}$			250	ps
$T_{jit}$	Additive Jitter	RMS @ 12KHz~20MHz		45.6		fs

**Notes:**

- With rail to rail input clock.
- All outputs with equal loading.
- Duty cycle on outputs will match incoming clock duty cycle.
- With external series resistor 33Ω positioned close to each output pin.

Jitter (RMS @ 12KHz~20MHz)

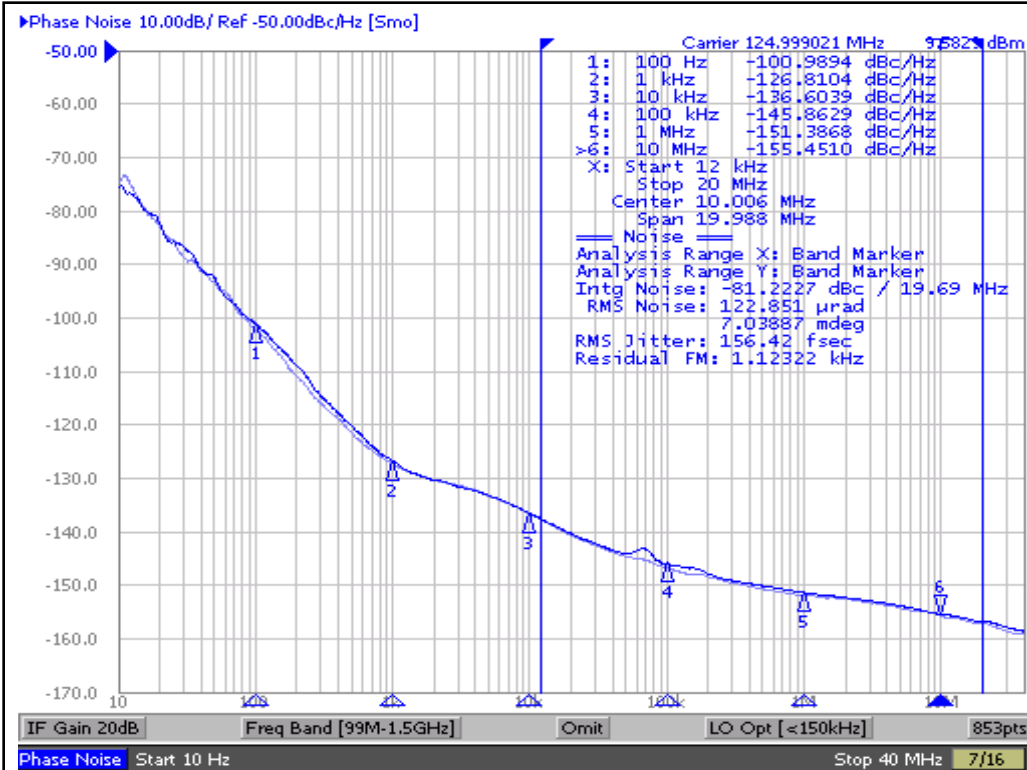

Output phase noise vs. input (light blue line) plot

Output RMS phase jitter=156.4fs

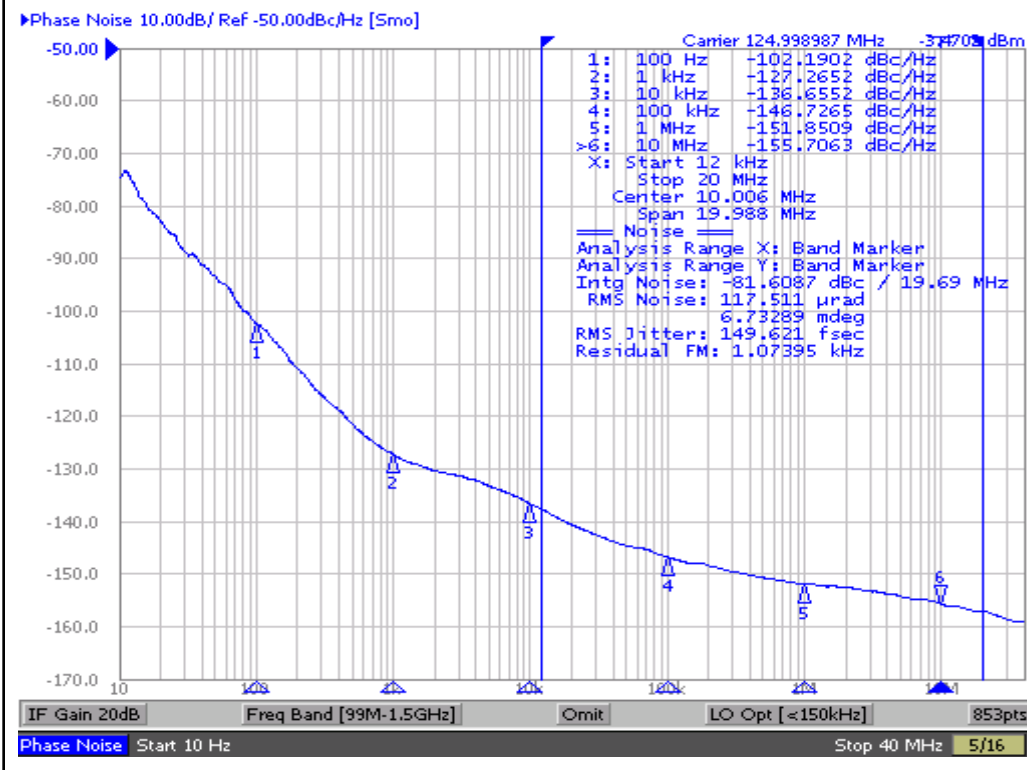

Input phase noise plot

Input RMS phase jitter=149.6fs

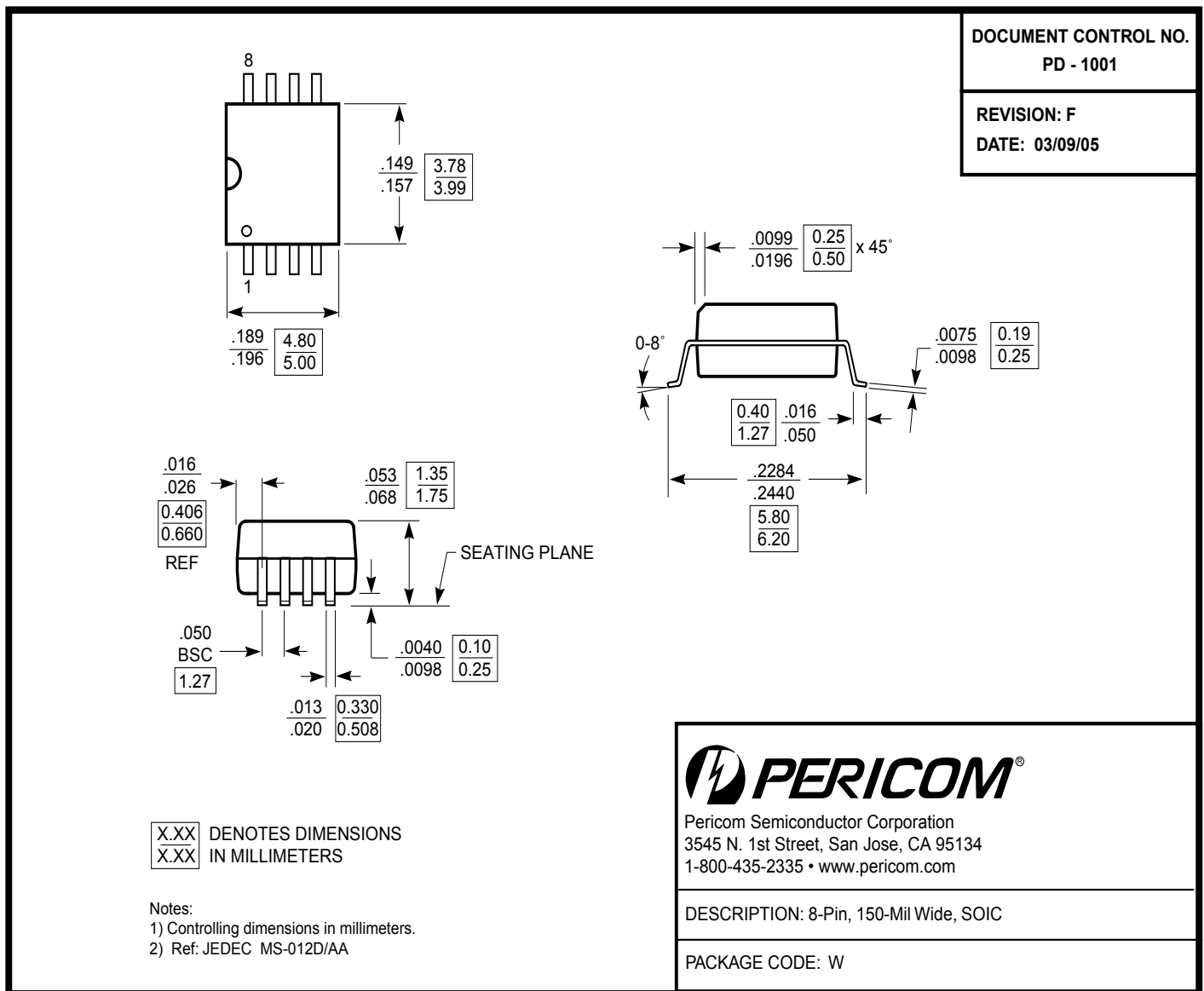
**Packaging Mechanical: 8-pin SOIC (W)**

**Ordering Information<sup>(1,2,3)</sup>:**

Ordering Code	Package Code	Package Description
PI6C18551WE	W	Pb-free & Green, 8-pin SOIC

**Notes:**

1. Thermal characteristics can be found on the company web site at [www.pericom.com/packaging/](http://www.pericom.com/packaging/)
2. E = Pb-free and Green
3. Adding an X Suffix = Tape/Reel

## X-ON Electronics

Largest Supplier of Electrical and Electronic Components

*Click to view similar products for [Clock Buffer](#) category:*

*Click to view products by [Pericom](#) manufacturer:*

Other Similar products are found below :

[PL133-27GI](#) [9DBV0541AKLF](#) [9DBV0941AKLF](#) [MPC962309EJ-1H](#) [NB3M8304CDG](#) [NB4N121KMNG](#) [NB7VQ58MMNG](#)  
[8T39S11ANLGI](#) [8T73S1802NLGI](#) [9DBV0941AKILF](#) [MC10E111FNG](#) [MK2308S-1HILF](#) [5PB1216NDGK](#) [6V31024NLG](#) [PL133-27GI-R](#)  
[9DBV0941AKILFT](#) [NB3L02FCT2G](#) [NB3L03FCT2G](#) [NB7VQ58MMNHTBG](#) [ZL40203LDG1](#) [ZL40200LDG1](#) [9DMV0141AKILFT](#)  
[ZL40205LDG1](#) [ZL40201LDG1](#) [9DBV0541AKILF](#) [PI49FCT32807QE](#) [552-02SPGGI](#) [9FG1200DF-1LF](#) [MDB1900ZCQY](#) [9ZXL1530DKILF](#)  
[8SLVP1102ANLGI/W](#) [ZL40223LDG1](#) [5PB1203NTGK8](#) [9FG1001BGLF](#) [MDB1900ZBQY](#) [5PB1213NTGK](#) [5PB1214CMGK](#)  
[ZL40202LDG1](#) [8L30205NLGI8](#) [5PB1204CMGK](#) [5PB1214CMGK8](#) [5PB1203NTGK](#) [5PB1206NDGK](#) [PI49FCT20802QE](#) [MAX9317AECJ+](#)  
[SL2305SC-1T](#) [PI6C10810HE](#) [5P1103A517NLGI](#) [9ZX21901DKLF](#) [NB7L1008MNG](#)