

RES80F01

Rev. 0

**CHARACTERISTICS:**

Rated Voltage:	250VAC max
Rated Current at Ambient:	1A @ 40°C
Operating Frequency:	DC-400HZ
Climatic Class (IEC60068-1):	25/100/21
Temperature Range:	-25°C to +100°C
Over load Current:	1.5 x Rated Ct. for 1 Min
Operational Leakage current : (at 230VAC/50Hz and Total C +/-20%)	0.734 mA max
Worst case Leakage current : (N interrupted and Total C +/-20%)	<1.101 mA max
DCR @ 25°C (+/-25%) :	900 mΩ
Test Voltage (100%) for 2 sec:-	L-N: 1100VDC L-GND: 3000VDC
Ingress Protection:	IP 20
Weight (Approximate):	200 gr

**FILTER PARAMETERS:**

Total Inductance (L-L'+N-N') @10KHz:	22.5mH +50%,-30%
Total Capacitance (L-L/L-N) @1KHz:	0.66μF +/- -20%
Total Capacitance (L/N-GND) @1KHz:	9.4nF +/- -20%
Total Resistance (L-L/L-N):	1MΩ +/- -10%
Total Resistance (L/N-GND):	

**APPROVALS:** REACH  
RoHS  
UL



APPROVED BY  
AJAY  
Date:25-04-2014

**CIRCUIT DIAGRAM:**

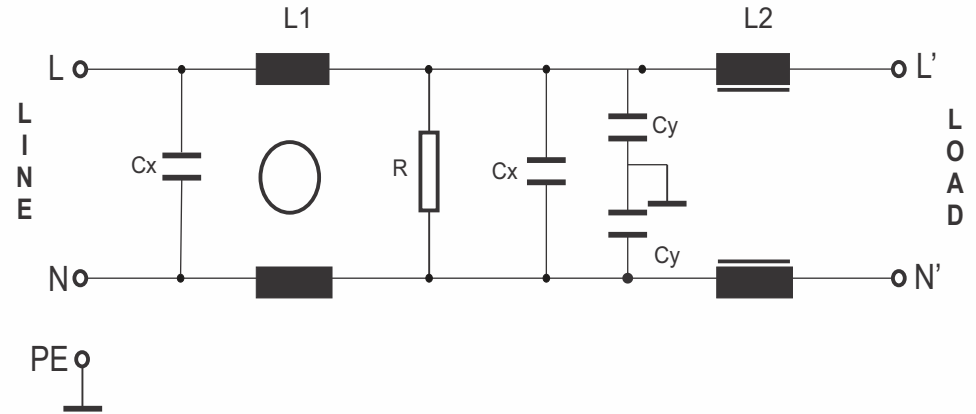

**MECHANICAL DIMENSION (mm):**

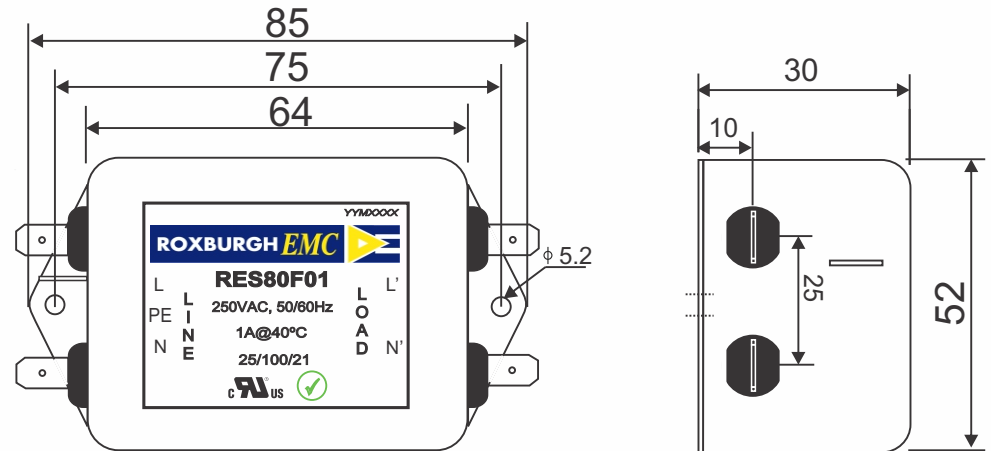

**Note:**

Housing matl. Fe with Ni Plated  
Fast-On Terminal ( 6.3 x 0.8mm)  
Connections

TOLERANCE: +/-1.0 mm



Tel:- +44(0) 1724 273200  
email:- sales@dem-uk.com  
web :- www.dem-uk.com/roxburgh

**ROXBURGH EMC**  
FILTER INSERTION LOSS CHARACTERISTICS  
CISPR 17 - 50 OHM METHOD

**RES80F01**

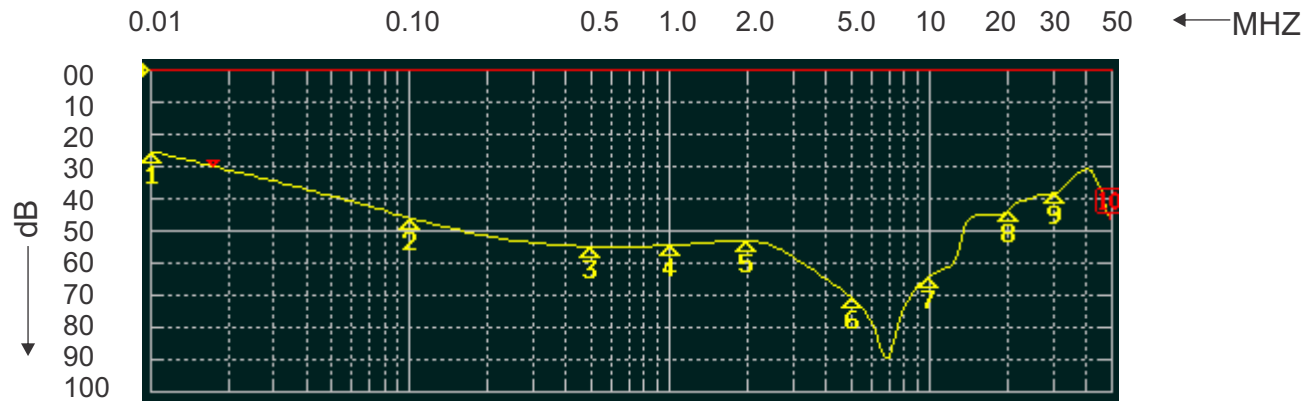

COMMON MODE

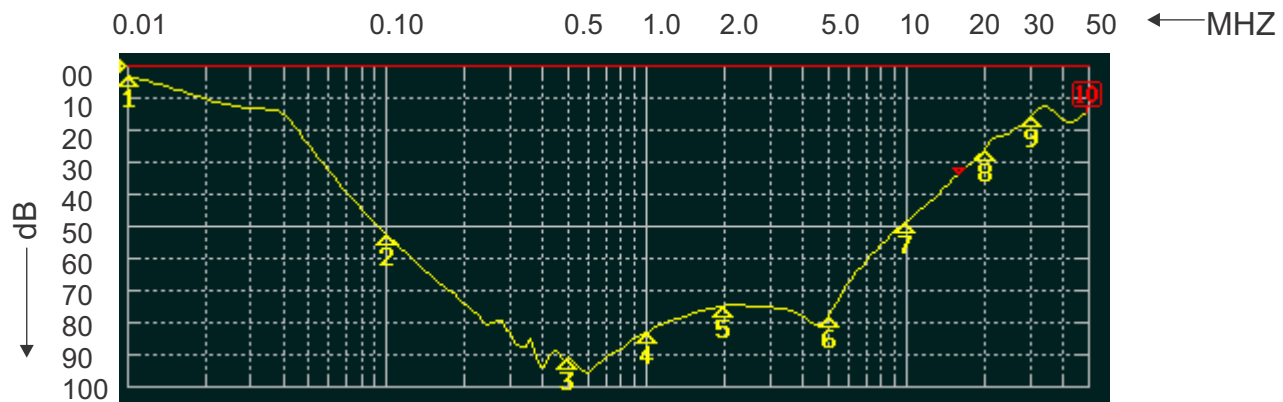

DIFFERENTIAL MODE



## **X-ON Electronics**

Largest Supplier of Electrical and Electronic Components

*Click to view similar products for [roxburgh](#) manufacturer:*

Other Similar products are found below :

[RES90F10](#) [KMF3100](#) [RIS0622H2](#) [XE12001](#) [SF1121](#) [RES5-FO8](#) [CMV10](#) [DVS24](#) [DRF10](#) [C225](#) [RES20F16](#) [RES20F20](#) [RES20F10](#)  
[DVS240](#) [XEB01010](#) [DRF08](#) [RES5-F15](#) [RIP0642H2](#) [DRF06](#) [C215](#) [RES10F06](#) [RES30F03](#) [XE0475](#) [RID-0342-H](#) [RES5-F10](#) [RIR-0622-H](#)  
[XE01010](#) [SMV20](#) [SF1123](#) [CMV30](#) [RIR-0222-H](#) [SF1122](#) [SMV40](#) [RIQ-0442-H2](#) [SMV10](#) [RX730RC+CLIP](#) [3CRH30330](#) [CMV20](#) [XE1201](#)  
[RE1201](#)