

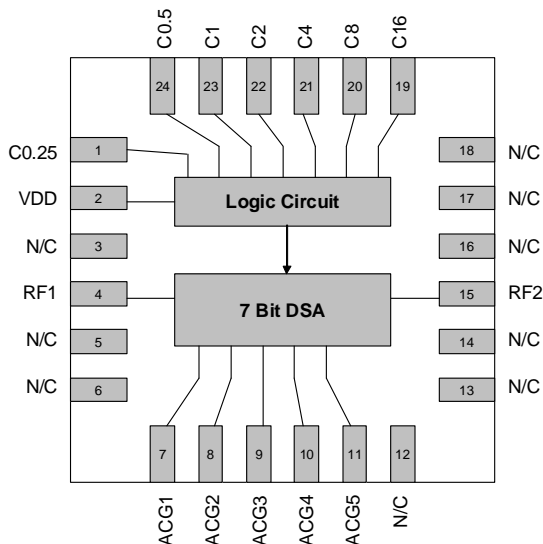

Features

- Frequency Range 50MHz to 4000MHz
- 7-Bit, 31.75dB Range, 0.25dB Step
- High Linearity, IP3 > 50dBm
- 3V and 5V Logic Compatible
- On-chip Parallel Decoder
- Parallel Programming Interface
- On-chip ESD Protection > 500V HBM
- Single Supply, 3V to 5V Operation
- Footprint Compatible with Most 24-Pin, 4mm x 4mm QFNs



Functional Block Diagram

Applications

- Transceiver IF Applications
- Cellular, PCS, GSM, UMTS, LTE,
- WiMax/WLAN
- Wireless Data, Satellite Terminals
- Test Equipment

Product Description

RFMD's RFSA2714 is a 7-bit Digital Step Attenuator (DSA) that features high linearity over the entire 31.75dB gain control range with excellent step accuracy in 0.25dB steps. The parallel-controlled RFSA2714 has an on-chip decoder that is both 3V and 5V compatible. The RFSA2714 also offers a rugged Class 1B HBM ESD rating via on-chip ESD circuitry. The MCM package is footprint compatible with most 24-pin, 4mm x 4 mm, QFN packages.

Ordering Information

RFSA2714SR	7" Reel with 100 pieces
RFSA2714SQ	Sample bag with 25 pieces
RFSA2714TR7	7" Reel with 750 pieces
RFSA2714TR13	13" Reel with 2500 pieces
RFSA2714PCK-410	PCBA with 5-piece sample bag

Optimum Technology Matching® Applied

- | | | | |
|--------------------------------------|--------------------------------------|--|-----------------------------------|
| <input type="checkbox"/> GaAs HBT | <input type="checkbox"/> SiGe BiCMOS | <input checked="" type="checkbox"/> GaAs pHEMT | <input type="checkbox"/> GaN HEMT |
| <input type="checkbox"/> GaAs MESFET | <input type="checkbox"/> Si BiCMOS | <input type="checkbox"/> Si CMOS | <input type="checkbox"/> RF MEMS |
| <input type="checkbox"/> InGaP HBT | <input type="checkbox"/> SiGe HBT | <input type="checkbox"/> Si BJT | <input type="checkbox"/> LDMOS |

RF MICRO DEVICES®, RFMD®, Optimum Technology Matching®, Enabling Wireless Connectivity™, PowerStar®, POLARIS™ TOTAL RADIO™ and UltimateBlue™ are trademarks of RFMD, LLC. BLUETOOTH is a trademark owned by Bluetooth SIG, Inc., U.S.A. and licensed for use by RFMD. All other trade names, trademarks and registered trademarks are the property of their respective owners. ©2006, RF Micro Devices, Inc.

Absolute Maximum Ratings

Parameter	Rating	Unit
Supply Voltage	+5.5	V
DC Supply Current	15	mA
Power Dissipation	83	mW
Max RF Input Power	27	dBm
Operating Temperature (Tcase)	-40 to +85	°C
Storage Temperature	-40 to +150	°C
Junction Temperature	150	°C
ESD Rating (HBM)	Class 1B	
Moisture Sensitivity Level	MSL1	



Caution! ESD sensitive device.

Exceeding any one or a combination of the Absolute Maximum Rating conditions may cause permanent damage to the device. Extended application of Absolute Maximum Rating conditions to the device may reduce device reliability. Specified typical performance or functional operation of the device under Absolute Maximum Rating conditions is not implied.

RoHS status based on EUDirective2002/95/EC (at time of this document revision).

The information in this publication is believed to be accurate and reliable. However, no responsibility is assumed by RF Micro Devices, Inc. ("RFMD") for its use, nor for any infringement of patents, or other rights of third parties, resulting from its use. No license is granted by implication or otherwise under any patent or patent rights of RFMD. RFMD reserves the right to change component circuitry, recommended application circuitry and specifications at any time without prior notice.

Parameter	Specification			Unit	Condition
	Min.	Typ.	Max.		
Frequency Range	50		4000	MHz	
Insertion Loss		0.85 1.1 1.6 2.1		dB	150MHz - 0dB attenuation 850MHz - 0dB attenuation 2700MHz - 0dB attenuation 3800MHz - 0dB attenuation
Gain Control Range		31.75		dB	0.25dB step size
Step Accuracy	+/- (0.1+4% attenuation setting)			dB	
Input IP3		50		dBm	100 - 4000MHz
Input P0.1dB		25		dBm	1000MHz
Return Loss		15		dB	DC - 3000MHz, all states
Control Interface		7-bit, Parallel			Parallel Interface
Settling Time		200		ns	t _{RISE} , t _{FALL} (10%/90% RF)
Switching Speed		200		ns	t _{ON} , t _{OFF} (50% CTL to 10%/90% RF)
Supply Voltage (V _{DD})	4.75	5.0	5.25	V	
Supply Current		7.5		mA	
Control Voltage (V _{CTL})	Low, V _{CTL} =0 to 0.8V High, V _{CTL} =2.0 to V _{DD}			V	
Notes:					
1. V _{DD} =5V, V _{CTL} =5V, T=25C					
2. Broadband Application Circuit (with ACG caps)					
3. IIP3 measured with Pin=+10dBm/tone, 1MHz spacing					

Typical Performance - Broadband Application Circuit (5V, 25 °C)

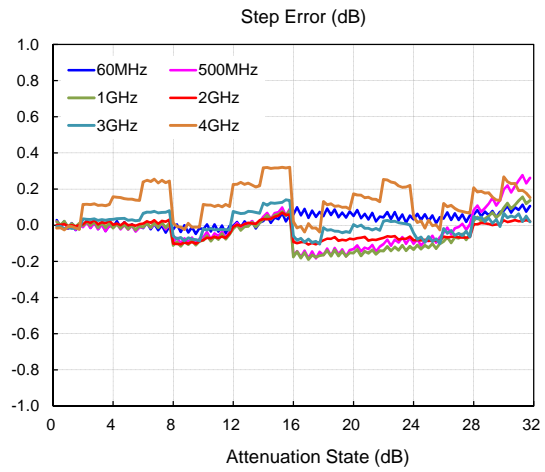
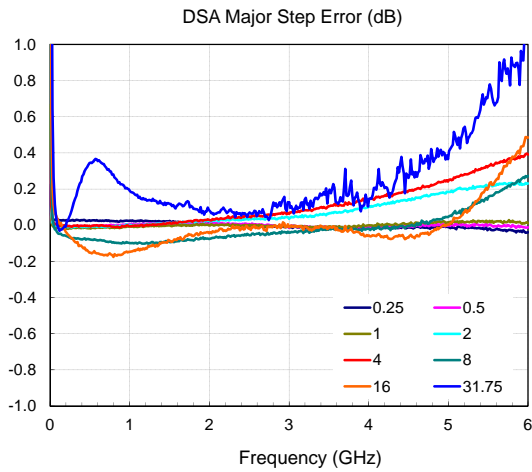
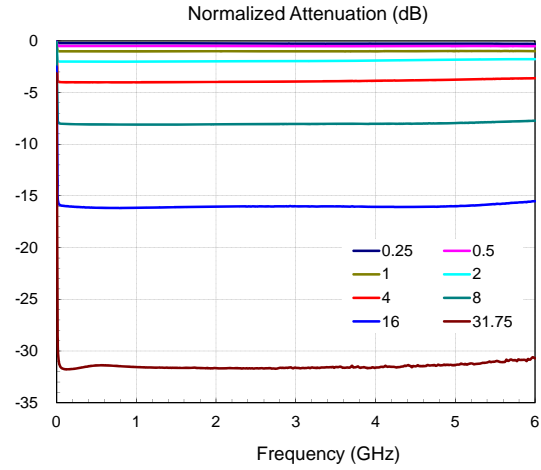
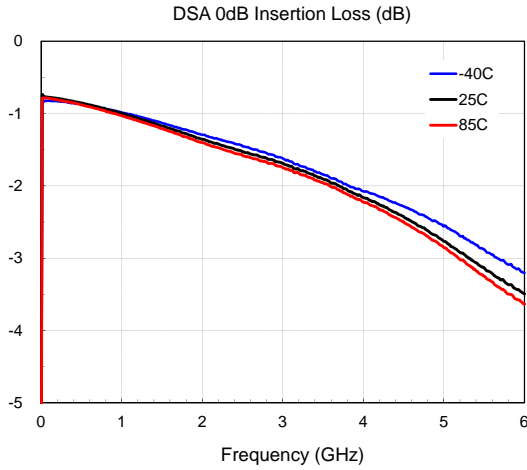

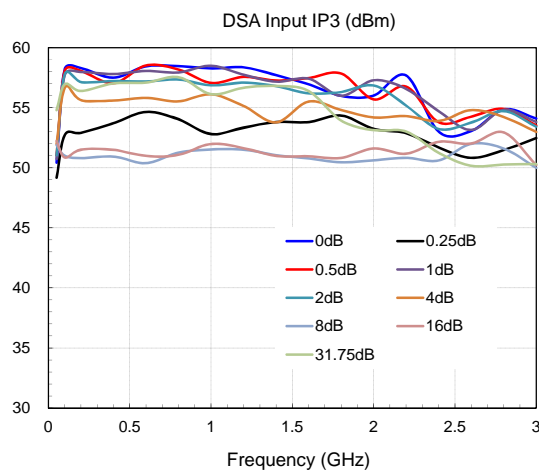
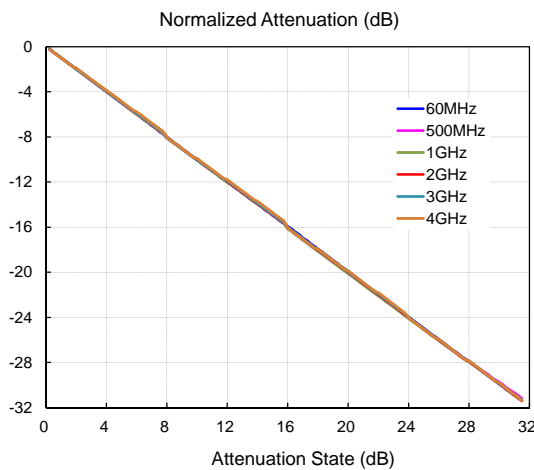
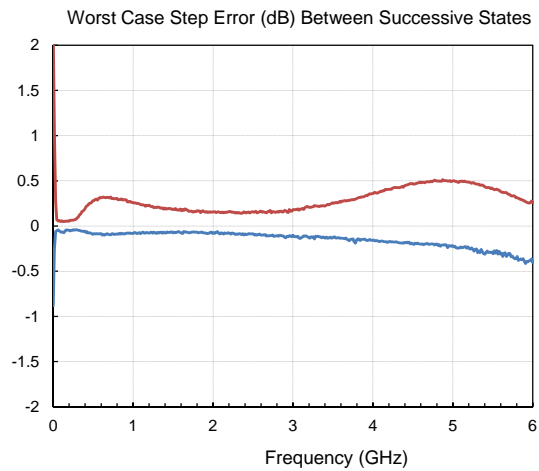
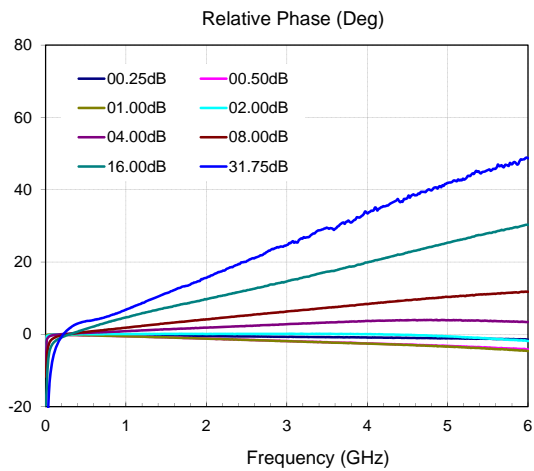
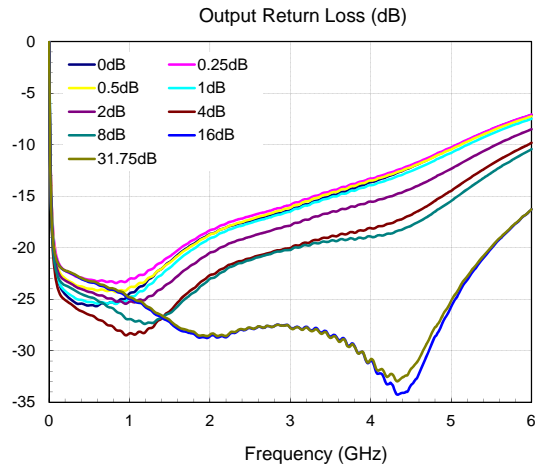
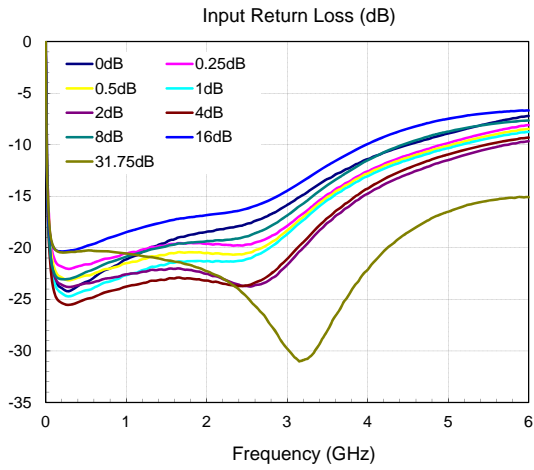

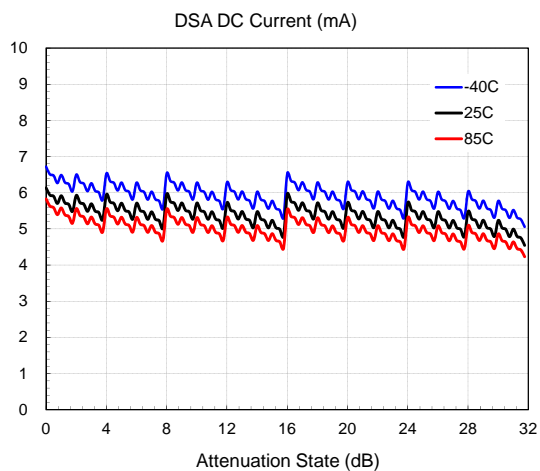

Truth Table

Control Bit							Relative Gain Setting
C16	C8	C4	C2	C1	C0.5	C0.25	
1	1	1	1	1	1	1	Max Gain
1	1	1	1	1	1	0	-0.25dB
1	1	1	1	1	0	1	-0.5dB
1	1	1	1	0	1	1	-1dB
1	1	1	0	1	1	1	-2dB
1	1	0	1	1	1	1	-4dB
1	0	1	1	1	1	1	-8dB
0	1	1	1	1	1	1	-16dB
0	0	0	0	0	0	0	-31.75dB

Note: C0.25=D0, C0.5=D1, ..., C16=D6 (for the purpose of the example below)

Logic Voltage Levels	
State	Logic
Low	0V to 0.8V
High	2.0V to 5.0V

Pin Name and Description Table

Pin	Function	Description
1	C0.25	0.25dB Control Bit
2	VDD	Power Supply
3	NC	No Internal Connection. EVB can be ground or no connect.
4	RF1	RF Port. External DC Block Required.
5	NC	No Internal Connection. EVB can be ground or no connect.
6	NC	No Internal Connection. EVB can be ground or no connect.
7	ACG	AC Ground Connection for Operation below 500MHz
8	ACG	AC Ground Connection for Operation below 500MHz
9	ACG	AC Ground Connection for Operation below 500MHz
10	ACG	AC Ground Connection for Operation below 500MHz
11	ACG	AC Ground Connection for Operation below 500MHz
12	NC	No Internal Connection. EVB can be ground or no connect.
13	NC	No Internal Connection. EVB can be ground or no connect.
14	NC	No Internal Connection. EVB can be ground or no connect.
15	RF2	RF Port. External DC Block Required.
16	NC	No Internal Connection. EVB can be ground or no connect.
17	NC	No Internal Connection. EVB can be ground or no connect.
18	NC	No Internal Connection. EVB can be ground or no connect.
19	C16	16dB Control Bit
20	C8	8dB Control Bit
21	C4	4dB Control Bit
22	C2	2dB Control Bit
23	C1	1dB Control Bit
24	C0.5	0.5dB Control Bit
EPAD	GND	DC & RF Ground. Must be soldered to EVB ground plane over a bed of vias for thermal and RF performance.

Evaluation Board Assembly Drawing

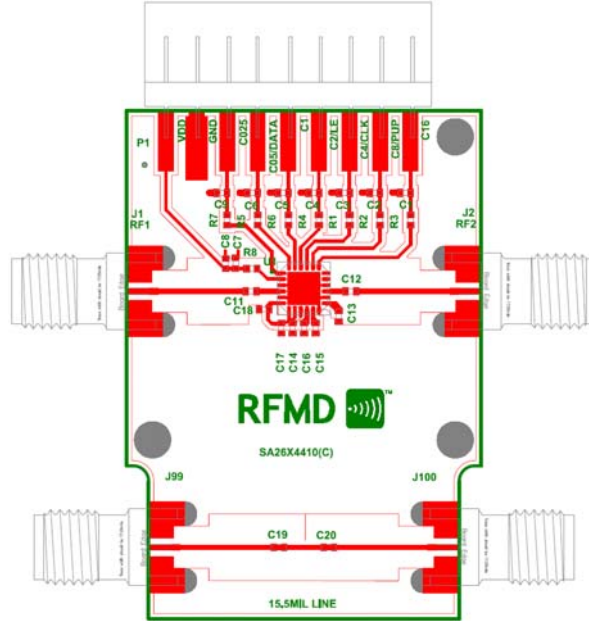

Evaluation Board Schematic

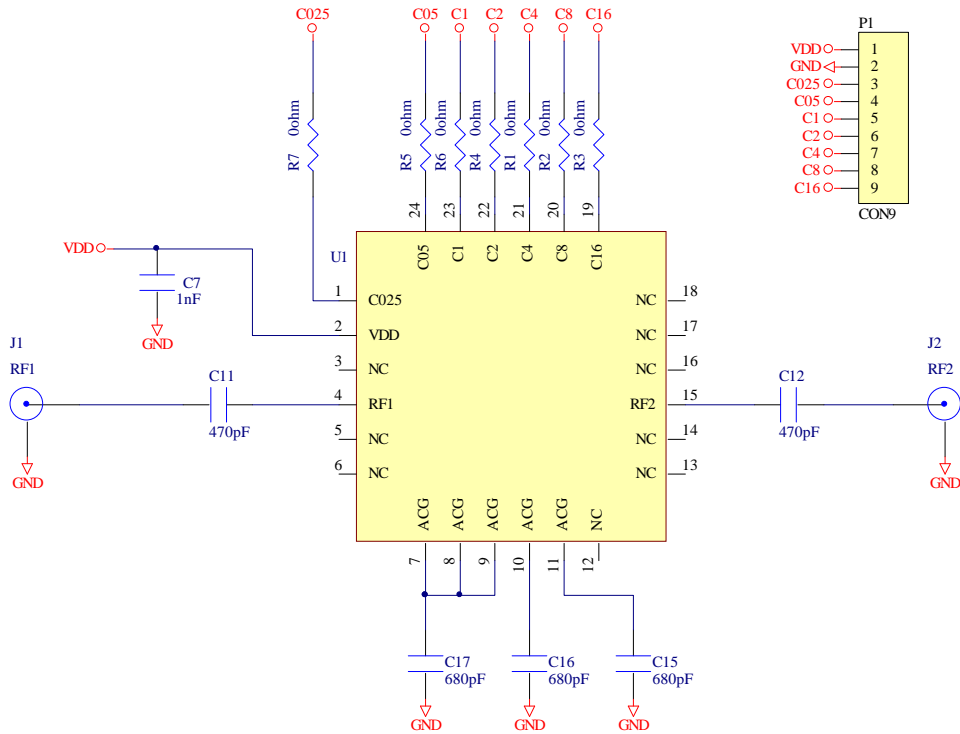

Evaluation Board Bill of Materials

Component	Description
U1	RFSA2714 Digital Step Attenuator
J1, J2	PCB Mount SMA Connector
P1	9-Pin DC Connector
C15, C16, C17	680pF Capacitor 0402
C8	1nF Capacitor 0402
C11, C12	470pF Capacitor 0402
R1, R2, R3, R4, R5, R6, R7	0Ω Resistor 0402

Package Outline Drawing

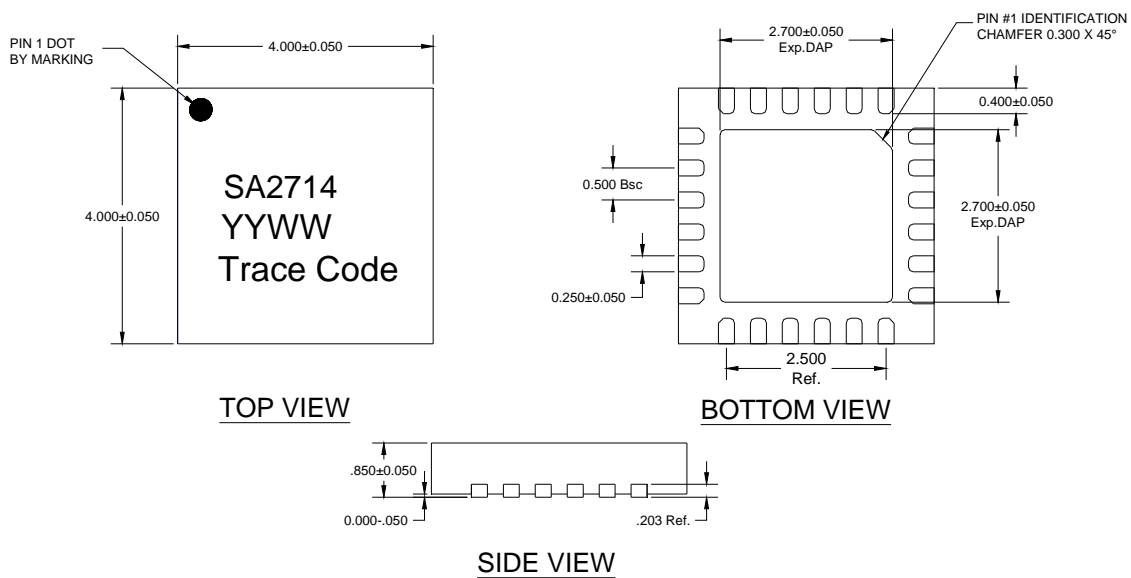

YYWW = Date Code, where YY=year, WW=week
 Trace Code to be assigned by assembly SubCon

X-ON Electronics

Largest Supplier of Electrical and Electronic Components

Click to view similar products for [rfmd](#) manufacturer:

Other Similar products are found below :

[S10040220GT](#) [S10040180P1](#) [NBB-400-T1](#) [SPF5189Z](#) [NBB-310-T1](#) [SPF5122Z](#) [SPF5043Z](#) [RFSA2033TR7](#)