

750kHz – 800MHz Low Phase Noise Multiplier VCXO

Universal Low Phase Noise ICs

FEATURES

- Selectable 750kHz to 800MHz range
- Low phase noise output (@ 10kHz frequency offset, -142dBc/Hz for 19.44MHz, -125dBc/Hz for 155.52MHz, -115dBc/Hz for 622.08MHz)
- LVCMOS (PL502-37), LVPECL (PL502-35 and PL502-38) or LVDS (PL502-39) output
- 12MHz to 25MHz crystal input
- No external load capacitor or varicap required.
- Output Enable selector
- Wide pull range (± 200 ppm)
- Selectable /16 to x32 frequency divider/multiplier
- 3.3V operation
- Available in 16-Pin TSSOP or 16-pin 3x3mm QFN GREEN/RoHS compliant packages

DESCRIPTION

The PL502-35 (LVPECL with inverted OE), PL502-37 (LVCMOS), PL502-38 (LVPECL), and PL502-39 (LVDS) are high performance and low phase noise VCXO IC chips. They provide phase noise performance as low as -125 dBc at 10kHz offset (at 155MHz), by multiplying the input crystal frequency up to 32x. The wide pull range (± 200 ppm) and very low jitter make them ideal for a wide range of applications, including SONET/SDH and FEC. They accept fundamental parallel resonant mode crystals from 12MHz to 25MHz.

BLOCK DIAGRAM

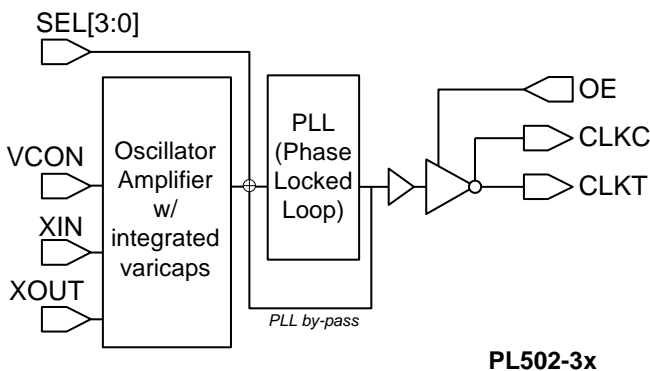

PIN CONFIGURATION

(Top View)

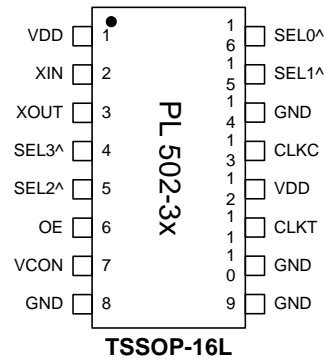

^: Internal pull-up

*: On 3x3 package, PL502-35/-38 do not have SEL0 available: Pin 10 is VDD, pin 11 is GND. However, PL502-37/-39 have SEL0 (pin 10), and pin11 is VDD. See pin assignment table for details.

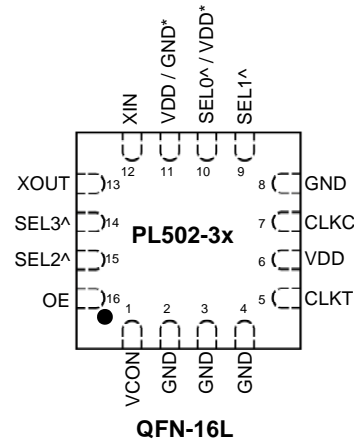

OUTPUT ENABLE LOGICAL LEVELS

Part #	OE	State
PL502-38	0 (Default)	Output enabled
	1	Tri-state
PL502-35 PL502-37 PL502-39	0	Tri-state
	1 (Default)	Output enabled

OE input: Logical states defined by LVPECL levels for PL502-38
Logical states defined by LVCMOS levels for PL502-37/-39



PL502-35/-37/-38/-39

750kHz – 800MHz Low Phase Noise Multiplier VCXO

Universal Low Phase Noise ICs

FREQUENCY SELECTION TABLE

SEL3	SEL2	SEL1	SEL0	Selected Multiplier
0	0	1	1	Fin x 32
0	1	1	0	Fin / 8
0	1	1	1	Fin x 2
1	0	0	1	Fin / 2
1	0	1	0	Fin / 16
1	0	1	1	Fin x 4
1	1	0	0	Fin / 4
1	1	0	1	Fin x 8
1	1	1	0	Fin x 16
1	1	1	1	No multiplication

Note: SEL0 is not available (always "1") for PL502-35 and PL502-38 in 3x3mm package

PIN DESCRIPTIONS PL502-35 and PL502-38 (see next page for PL502-37/-39)

Name	TSSOP Pin number	3x3mm QFN Pin number	Type	Description
XIN	2	12	I	Crystal input (See Crystal Specification on page 4)
XOUT	3	13	I	Crystal output (See Crystal Specification on page 4)
OE	6	16	I	Output enable pin (See OE logic state table on page 1)
VCON	7	1	I	Voltage Control input
GND	8,9,10,14	2,3,4,8,11	P	Ground connection
CLKT	11	5	O	LVPECL True output
CLKC	13	7	O	LVPECL Complementary output
SEL0	16	Not available	I	Multiplier selector pins. These pins have an internal pull-up that will default SEL to '1' when not connected to GND.
SEL1	15	9	I	
SEL2	5	15	I	
SEL3	4	14	I	
VDD	1, 12	6,10	P	+3.3V power supply.



PL502-35/-37/-38/-39

750kHz – 800MHz Low Phase Noise Multiplier VCXO

Universal Low Phase Noise ICs

PIN DESCRIPTIONS PL502-37/-39 (see previous page for PL502-35/-38)

Name	TSSOP Pin number	3x3mm QFN Pin number	Type	Description
XIN	2	12	I	Crystal input. See Crystal Specification on page 4.
XOUT	3	13	I	Crystal output. See Crystal Specification on page 4.
OE	6	16	I	Output enable pin (see OE logic state table on page 1).
VCON	7	1	I	Voltage Control input.
GND	8,9,10,14	2,3,4,8	P	Ground.
CLKT	11	5	O	LVDS True output for PL502-39 No Connect for PL502-37
CLKC	13	7	O	LVDS Complementary output for PL502-39 LVCMOS out for PL502-37
SEL0	16	10	I	Multiplier selector pins. These pins have an internal pull-up that will default SELx to '1' when not connected to GND.
SEL1	15	9	I	
SEL2	5	15	I	
SEL3	4	14	I	
VDD	1, 12	6,11	P	+3.3V power supply.

ELECTRICAL SPECIFICATIONS

1. Absolute Maximum Ratings

PARAMETERS	SYMBOL	MIN.	MAX.	UNITS
Supply Voltage	V_{DD}		4.6	V
Input Voltage, dc	V_I	-0.5	$V_{DD}+0.5$	V
Output Voltage, dc	V_O	-0.5	$V_{DD}+0.5$	V
Storage Temperature	T_S	-65	150	°C
Ambient Operating Temperature*	T_A	-40	85	°C
Junction Temperature	T_J		125	°C
Lead Temperature (soldering, 10s)			260	°C
ESD Protection, Human Body Model			2.5	kV

Exposure of the device under conditions beyond the limits specified by Maximum Ratings for extended periods may cause permanent damage to the device and affect product reliability. These conditions represent a stress rating only, and functional operations of the device at these or any other conditions above the operational limits noted in this specification is not implied.

* **Note:** Operating Temperature is guaranteed by design for all parts (COMMERCIAL and INDUSTRIAL), but tested for COMMERCIAL grade only.

750kHz – 800MHz Low Phase Noise Multiplier VCXO

Universal Low Phase Noise ICs

2. Crystal Specifications

PARAMETERS	SYMBOL	CONDITIONS	MIN.	TYP.	MAX.	UNITS
Crystal Resonator Frequency	F_{XIN}	Parallel Fundamental Mode	12		25	MHz
Crystal Loading Rating	$C_{L(xtal)}$	At $V_{CON} = 1.65V$		9.5		pF
Crystal Pullability	$C_0/C_1(xtal)$	AT cut			250	-
Recommended ESR	R_E	AT cut			30	Ω

Note: Crystal Loading rating: 9.5pF is the loading the crystal sees from the VCXO chip at $V_{CON} = 1.65V$. It is assumed that the crystal will be at nominal frequency at this load. If the crystal requires more load to be at nominal frequency, the additional load must be added externally. This however may reduce the pull range.

3. Voltage Control Crystal Oscillator

PARAMETERS	SYMBOL	CONDITIONS	MIN.	TYP.	MAX.	UNITS
VCXO Stabilization Time *	$T_{VCXOSTB}$	From power valid			10	ms
VCXO Tuning Range		$F_{XIN} = 12 - 25MHz$; $XTAL C_0/C_1 < 250$ $0V \leq V_{CON} \leq 3.3V$		500		ppm
CLK output pullability		$V_{CON} = 1.65V, \pm 1.65V$	± 200			ppm
VCXO Tuning Characteristic				150		ppm/V
Pull range linearity					10	%
VCON pin input impedance			2000			k Ω
VCON modulation BW		$0V \leq V_{CON} \leq 3.3V, -3dB$	10			kHz

Note: Parameters denoted with an asterisk (*) represent nominal characterization data and are not production tested to any specific limits.

4. General Electrical Specifications

PARAMETERS	SYMBOL	CONDITIONS	MIN.	TYP.	MAX.	UNITS	
Supply Current, Dynamic (with Loaded Outputs)	I_{DD}	LVPECL/LVDS/LVCMOS	$F_{OUT} < 24MHz$			60/28/15	mA
			$24MHz < F_{OUT} < 96MHz$			65/45/30	
			$96MHz < F_{OUT} < 800MHz$			100/80/40	
Operating Voltage	V_{DD}		2.97		3.63	V	
Output Clock Duty Cycle		@ 50% V_{DD} (LVCMOS)	45	50	55	%	
		@ 1.25V (LVDS)	45	50	55		
		@ $V_{DD} - 1.3V$ (LVPECL)	45	50	55		
Short Circuit Current				± 50		mA	

750kHz – 800MHz Low Phase Noise Multiplier VCXO

Universal Low Phase Noise ICs

5. Jitter Specifications

PARAMETERS	CONDITIONS	FREQUENCY	MIN.	TYP.	MAX.	UNITS
Period jitter RMS	With capacitive decoupling between V _{DD} and GND. Over 10,000 cycles.	19.44MHz		2.2		ps
		77.76MHz		4.5		
		155.52MHz		4.5		
		622.08MHz		5.0		
Period jitter Peak-to-Peak	With capacitive decoupling between V _{DD} and GND. Over 10,000 cycles.	19.44MHz		17		ps
		77.76MHz		25		
		155.52MHz		27		
		622.08MHz		35		
Integrated jitter RMS	Integrated 12kHz to 20MHz	155.52MHz		2.5	4	ps
		622.08MHz		2.5	4	

6. Phase Noise Specifications

PARAMETERS	FREQUENCY	@10Hz	@100Hz	@1kHz	@10kHz	@100kHz	UNITS
Phase Noise relative to carrier (typical)	19.44MHz	-80	-108	-132	-142	-150	dBc/Hz
	77.76MHz	-72	-103	-122	-130	-125	
	155.52MHz	-65	-95	-120	-125	-121	
	622.08MHz	-55	-85	-109	-115	-110	

Note: Phase Noise measured at VCON = 0V

7. LVCMOS Electrical Characteristics

PARAMETERS	SYMBOL	CONDITIONS	MIN.	TYP.	MAX.	UNITS
Output drive current	I _{OH}	V _{OH} = V _{DD} -0.4V, V _{DD} =3.3V	10			mA
	I _{OL}	V _{OL} = 0.4V, V _{DD} = 3.3V	10			mA
Output Clock Rise/Fall Time		0.3V ~ 3.0V with 15 pF load		2.4		ns

750kHz – 800MHz Low Phase Noise Multiplier VCXO

Universal Low Phase Noise ICs

8. LVDS Electrical Characteristics

PARAMETERS	SYMBOL	CONDITIONS	MIN.	TYP.	MAX.	UNITS
Output Differential Voltage	V_{OD}	$R_L = 100\Omega$ (see figure)	247	355	454	mV
V_{DD} Magnitude Change	ΔV_{OD}		-50		50	mV
Output High Voltage	V_{OH}			1.4	1.6	V
Output Low Voltage	V_{OL}		0.9	1.1		V
Offset Voltage	V_{OS}		1.125	1.2	1.375	V
Offset Magnitude Change	ΔV_{OS}		0	3	25	mV
Power-off Leakage	I_{OXD}	$V_{out} = V_{DD}$ or GND $V_{DD} = 0V$		± 1	± 10	μA
Output Short Circuit Current	I_{OSD}			-5.7	-8	mA

9. LVDS Switching Characteristics

PARAMETERS	SYMBOL	CONDITIONS	MIN.	TYP.	MAX.	UNITS
Differential Clock Rise Time	t_r	$R_L = 100\Omega$ $C_L = 10\text{ pF}$ (see figure)	0.2	0.7	1.0	ns
Differential Clock Fall Time	t_f		0.2	0.7	1.0	ns

LVDS Levels Test Circuit

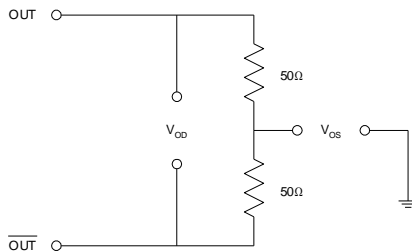

LVDS Switching Test Circuit

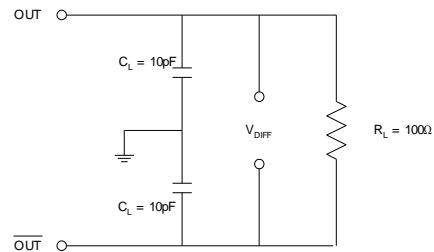

LVDS Transition Time Waveform

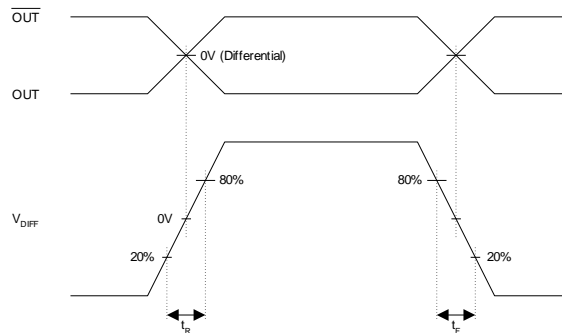

750kHz – 800MHz Low Phase Noise Multiplier VCXO

Universal Low Phase Noise ICs

10. LVPECL Electrical Characteristics

PARAMETERS	SYMBOL	CONDITIONS	MIN.	MAX.	UNITS
Output High Voltage	V_{OH}	$R_L = 50\Omega$ to ($V_{DD} - 2V$) (see figure)	$V_{DD} - 1.025$		V
Output Low Voltage	V_{OL}			$V_{DD} - 1.620$	V

11. LVPECL Switching Characteristics

PARAMETERS	SYMBOL	CONDITIONS	MIN.	TYP.	MAX.	UNITS
Clock Rise Time	t_r	20%~80% of Waveform		0.6	1.5	ns
Clock Fall Time	t_f			0.6	1.5	ns

LVPECL Levels Test Circuit

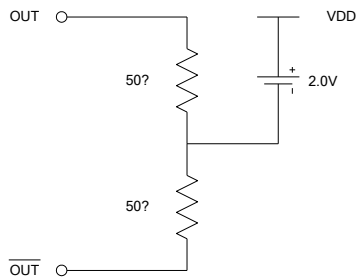

LVPECL Output Skew

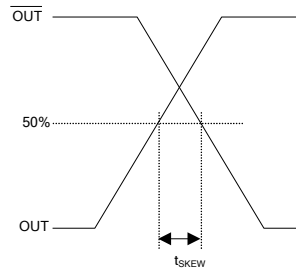

LVPECL Transition Time Waveform

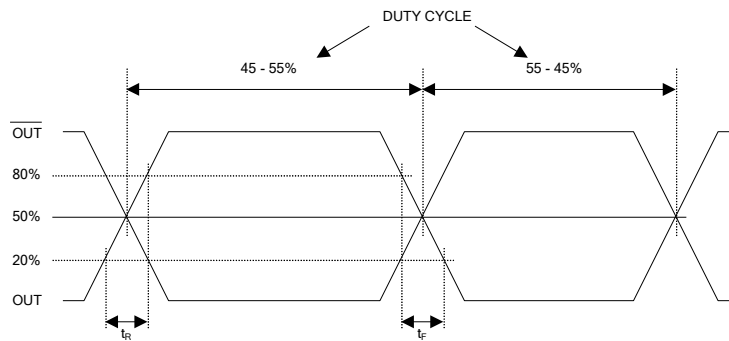

750kHz – 800MHz Low Phase Noise Multiplier VCXO

Universal Low Phase Noise ICs

PACKAGE INFORMATION (GREEN PACKAGE COMPLIANT)

TSSOP-16L

Symbol	Dimension in MM	
	Min.	Max.
A	-	1.20
A1	0.05	0.15
b	0.19	0.30
C	0.09	0.20
D	4.90	5.10
E	4.30	4.50
H	6.20	6.60
L	0.45	0.75
e	0.65 BSC	

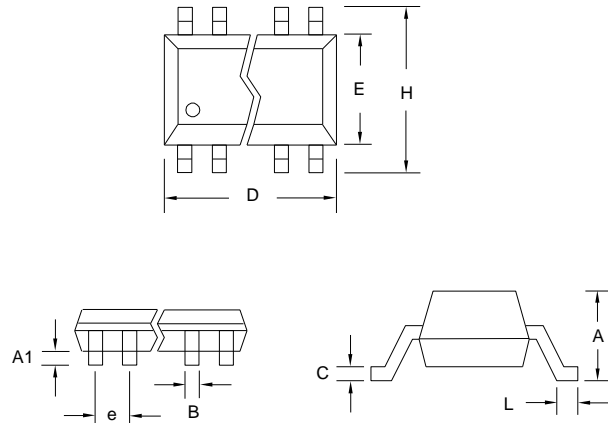

QFN-16L

Symbol	Dimension (mm)		
	Min	Nom	Max
A	0.70	0.75	0.80
A1	0.00	-	0.05
A3	0.203		
b	0.20	0.25	0.30
D	2.95	3.00	3.05
E	2.95	3.00	3.05
D1	1.65	1.70	1.75
E1	1.65	1.70	1.75
L	0.250	0.300	0.350
e	0.50BSC		

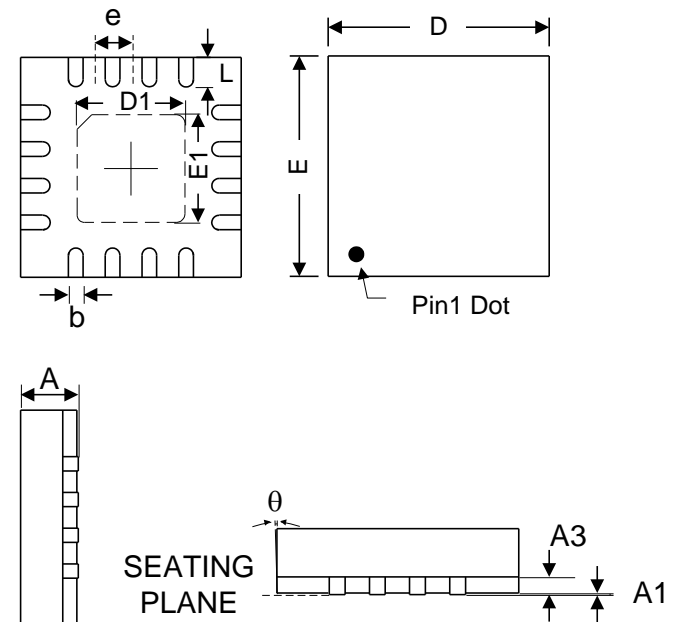

750kHz – 800MHz Low Phase Noise Multiplier VCXO

Universal Low Phase Noise ICs

ORDERING INFORMATION

For part ordering, please contact our Sales Department:

2180 Fortune Drive, San Jose, CA 95131, USA

Tel: (408) 944-0800 Fax: (408) 474-1000

PART NUMBER

The order number for this device is a combination of the following:

Part number, Package type, Operating temperature range, shipping method

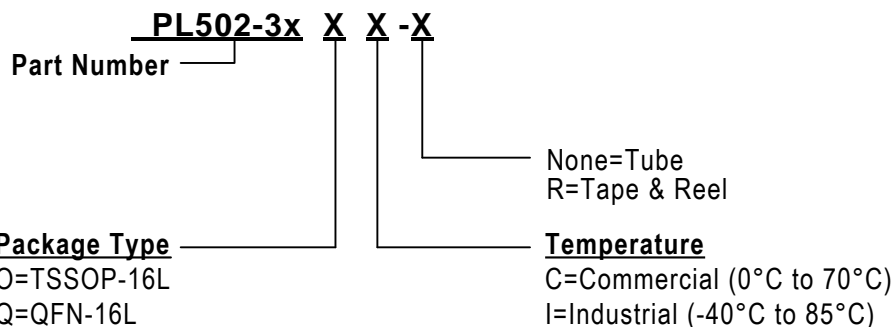

Part/Order Number*	Marking**		Package Option
	Commercial	Industrial	
PL502-35OC	P502-35 OC	P502-35 OI	8-pin TSSOP-16L – (Tube)
PL502-35OC-R	LLLLL	LLLLL	8-pin TSSOP-16L – (Tape and Reel)
PL502-35QC-R	P502 35 LLL	P502 35I LLL	16-pin QFN-16L - (Tape and Reel)
PL502-37OC	P502-37 OC	P502-37 OI	8-pin TSSOP-16L – (Tube)
PL502-37OC-R	LLLLL	LLLLL	8-pin TSSOP-16L – (Tape and Reel)
PL502-37QC-R	P502 37 LLL	P502 37I LLL	16-pin QFN-16L - (Tape and Reel)
PL502-38OC	P502-38 OC	P502-38 OI	8-pin TSSOP-16L – (Tube)
PL502-38OC-R	LLLLL	LLLLL	8-pin TSSOP-16L – (Tape and Reel)
PL502-38QC-R	P502 38 LLL	P502 38I LLL	16-pin QFN-16L - (Tape and Reel)
PL502-39OC	P502-39 OC	P502-39 OI	8-pin TSSOP-16L – (Tube)
PL502-39OC-R	LLLLL	LLLLL	8-pin TSSOP-16L – (Tape and Reel)
PL502-39QC-R	P502 39 LLL	P502 39I LLL	16-pin QFN-16L - (Tape and Reel)

*Note: For Industrial use "I" instead of "C" in the Part/Order number.

**Note: "LLL" or "LLLLL" are designates lot number



PL502-35/-37/-38/-39

750kHz – 800MHz Low Phase Noise Multiplier VCXO

Universal Low Phase Noise ICs

Micrel Inc., reserves the right to make changes in its products or specifications, or both at any time without notice. The information furnished by Micrel is believed to be accurate and reliable. However, Micrel makes no guarantee or warranty concerning the accuracy of said information and shall not be responsible for any loss or damage of whatever nature resulting from the use of, or reliance upon this product.

LIFE SUPPORT POLICY: *Micrel's products are not authorized for use as critical components in life support devices or systems without the express written approval of the President of Micrel Inc.*

X-ON Electronics

Largest Supplier of Electrical and Electronic Components

Click to view similar products for [Clock Synthesizer / Jitter Cleaner](#) category:

Click to view products by [Microchip](#) manufacturer:

Other Similar products are found below :

[CY28323OXC](#) [MPC9230EIR2](#) [8T49N287A-998NLGI](#) [8T49N286A-999NLGI](#) [PI6CX201ALE](#) [8T49N285A-999NLGI](#) [PL902166USY](#)
[954204CGLF](#) [252MI-52LF](#) [9LPRS485DGLF](#) [8T49N285A-998NLGI](#) [P1P8160AG-10CR](#) [DS31406GN+](#) [PL902167USY](#) [8T49N287A-](#)
[999NLGI](#) [8T49N286A-998NLGI](#) [AD9542BCPZ](#) [8T49N287A-041NLGI](#) [SI5344H-D-GM](#) [8A34001E-000AJG](#) [HMC822LP6CETR](#) [SI5345D-](#)
[A03700-GM](#) [83PN187DKILF](#) [CS230009-CZZ](#) [8T49N287-999NLGI](#) [84330CYLN](#) [83PN625DKILF](#) [83PN156DKILF](#) [MK2703BSLFTR](#)
[954101DFLF](#) [AD9578BCPZ-REEL7](#) [SM802124UMG](#) [8T49N286-999NLGI](#) [840001BGLF](#) [251PMLF](#) [SI5324E-C-GM](#) [SI5324D-C-GM](#)
[PI6CX201ALE](#) [841S101EGILFT](#) [LMK04808BISQ/NOPB](#) [8T49N287-998NLGI](#) [291PGILF](#) [9LRS3165BGLFT](#) [SI2168-D60-GMR](#) [SI5347A-](#)
[B03693-GM](#) [SI5347A-D-GM](#) [SI5347A-D04325-GM](#) [83PN15639ANRGI](#) [8430252CGI-45LF](#) [9LPRS365BGLFT](#)