

Electrical Interconnections

Supplementary Catalog to
Full Line Catalogs, Volumes 1/2/5
Edition 2014/2

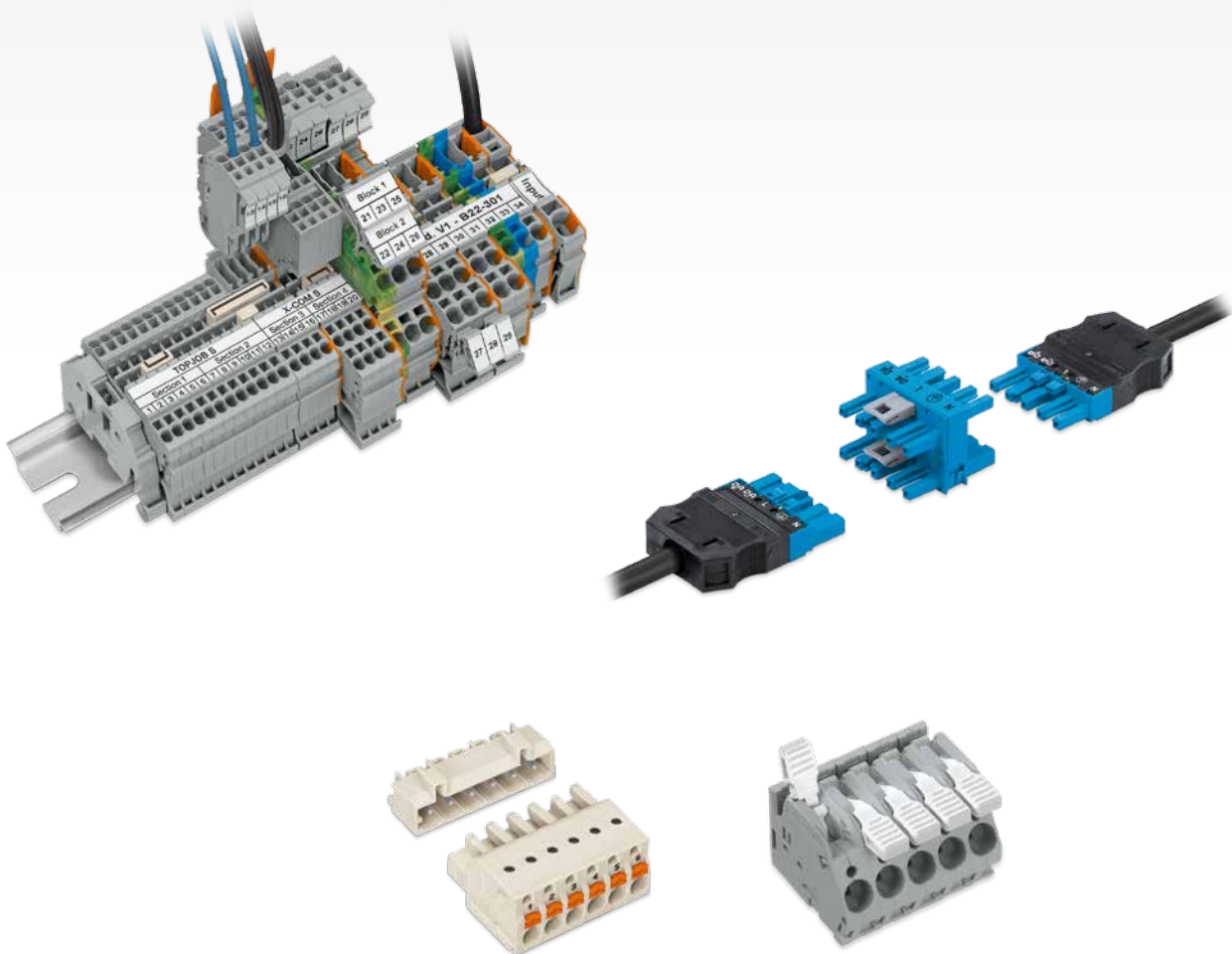

The new items in this catalog supplement products found in the following main catalogs

N 1/2/5

Volume 5
WINSTA® - The Pluggable Connection System



Volume 2
Connectors and PCB Terminal Blocks

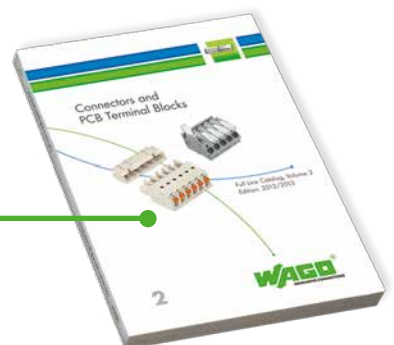

Volume 1
Rail-Mounted Terminal Block Systems

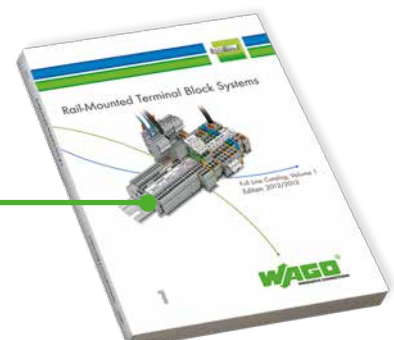

CONTENTS



Rail-Mounted Terminal Block Systems

Volume 1

02 – 55



Connectors and PCB Terminal Blocks

Volume 2

56 – 99



WINSTA® - The Pluggable Connection System

Volume 5

100 – 125



Marking

126 – 129



Tools

130

Item Numbers

132 – 135

CONTENTS

Volume 1



TOPJOB®
 Double-Deck Terminal Blocks 1 mm² 2000 Series 04 – 05
 Shield Terminal Blocks 6/10/16 mm² 2006 – 2016 Series 08



Double-Deck Terminal Blocks 2.5 mm² 2002 Series 07
 Colored Push-In Type Jumper Bars 2000 Series 12
 Pluggable Diode Modules on
 Carrier Terminal Blocks 2.5 mm² 2002 Series 09



TOPJOB®
 Multilevel Installation Terminal Blocks 2.5 mm² 2003 Series 10

Double Fuse Plugs 2003 Series 12

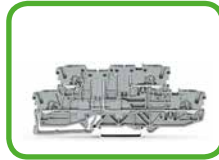

TOPJOB®
 Double-Deck Carrier Terminal Blocks 2.5 mm² 2002 Series 15

Colored Push-In Type Jumper Bars 2000 Series 14



TOPJOB®
 Double-Deck Terminal Blocks 2.5 mm² 2002 Series 16

Double-Deck Disconnect Terminal Blocks and
 Double-Deck Carrier Terminal Blocks 2.5 mm² 2002 Series 18

Double-Deck Fuse Disconnect
 Terminal Blocks 2.5 mm² 2002 Series 19

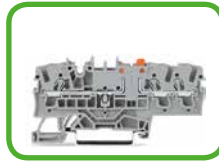

TOPJOB®
 3-Conductor Disconnect Terminal Blocks for
 Test and Measurement 2.5 mm² 2002 Series 20

**3-Conductor-Fuse Terminal Blocks and
 Carrier Terminal Blocks 2.5 mm²** 2002 Series 22



TOPJOB®
 Disconnect Terminal Blocks for Test and Measurement,
 Through and Ground Terminal Blocks
 for Current and Voltage Transformer Circuits
 6 mm² 2007 Series 28 – 29



TOPJOB®
 Terminal Block Assemblies for Current and
 Voltage Transformers 2007 Series 30 – 31



TOPJOB®
 Disconnect Terminal Blocks for Test and Measurement,
 Through and Carrier Terminal Blocks 6 mm² 2006 Series 32

Disconnect Plug for Carrier Terminal Blocks 2006 Series 32



Fuse Terminal Blocks for Cylindrical Fuses 811 Series 34

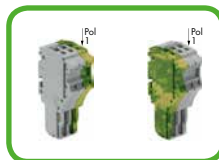

X-COM®-SYSTEM-MINI
 Pre-Assembled Female Plugs 1 mm² 2020 Series 36 – 37

X-COM®-SYSTEM
 Male Headers with Solder Pins and
 Rivet Fixing Flanges, Pin Spacing 5 mm 769 Series 38

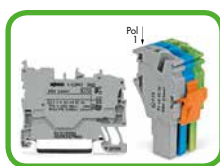

X-COM® -SYSTEM
Carrier Terminal Blocks and Female Plugs
2.5 mm² for Ex Applications

2022 Series

40 – 45



Busbar Carriers

790 Series

46

Voltage Tap

283 Series

47

High-Current, Rail-Mounted Terminal
Blocks 185 mm²

285 Series

50

COMPACT PUSH WIRE® Connectors for
Junction Boxes

221 Series

53



Vario-T-BOXX and Variobox

887 Series

54

Separators for Matrix Patching Terminal Blocks

280 Series

55

Lighting Connectors

294 Series

55

Strain Relief Plates for 294 Series

55

TOPJOB® Double-Deck Terminal Blocks 1 (1.5) mm² 2000 Series



0.14 - 1 (1.5) mm² ① | AWG 24 - 16
500 V/6 kV/3 ②
I_N 13.5 A (16 A)
Terminal block width 3.5 mm / 0.138 in
9 - 11 mm / 0.39 in ③

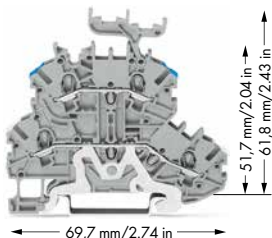

- ① Conductor sizes: 0.14 mm² - 1.5 mm² "s + f-st";
Push-in conductor sizes: 0.5 mm² - 1.5 mm² "s"
and 0.5 mm² - 0.75 mm²
"insulated ferrule, 10 mm"
- ② 500 V = rated voltage
6 kV = rated surge voltage
3 = pollution degree
(see Full Line Catalog, Volume 1, Section 14)
- ③ Strip length, see packaging or instructions.

Item No.	Pack. Unit	2000 Series Accessories	
Ground conductor/through terminal block, with marker carrier, gray housing		Appropriate marking systems: WMB/Marking strips (see Full Line Catalog, Volume 1, Section 13)	
Shield/N	2000-2248	50	
Shield/L	2000-2258	50	
Ground conductor/through terminal block, without marker carrier, gray housing			
Shield/N	2000-2218	50	
Shield/L	2000-2228	50	
		End and intermediate plate, 0.7 mm thick	
		orange	2000-2292 25
		gray	2000-2291 25
		Test plug adapter,	
			for 4 mm Ø test plug
		gray	2009-174 100 (4x25)
		Push-in type jumper bar, insulated,	
		I _N 14 A, light gray	
		2-way	2000-402 200 (8x25)
		3-way	2000-403 200 (8x25)
		4-way	2000-404 200 (8x25)
		5-way	2000-405 100 (4x25)
		6-way	2000-406 100 (4x25)
		7-way	2000-407 100 (4x25)
		8-way	2000-408 100 (4x25)
		9-way	2000-409 100 (4x25)
		10-way	2000-410 100 (4x25)
		Push-in type jumper bar, insulated,	
		I _N 14 A, light gray	
		from 1 to 3	2000-433 200 (8x25)
		from 1 to 4	2000-434 200 (8x25)
		from 1 to 5	2000-435 100 (4x25)
		from 1 to 6	2000-436 100 (4x25)
		from 1 to 7	2000-437 100 (4x25)
		from 1 to 8	2000-438 100 (4x25)
		from 1 to 9	2000-439 100 (4x25)
		from 1 to 10	2000-440 100 (4x25)
		Protective warning marker,	
		with high-voltage symbol, black, for 5 terminal blocks	
		yellow	2000-115 100 (4x25)
		Double-deck marker carrier,	
		pivoting	
		gray	2000-121 50 (2x25)
		WMB Multi marking system,	
		10 strips with 10 markers per card, for 3.5 mm terminal block width	
		plain	793-3501 5
		Marking strip, plain,	
		11 mm wide, 50 m roll	
		white	2009-110 1
		Banana plug,	
			for socket 4 mm Ø, color mixed
			215-111 50
		Testing tap,	
			for max. 2.5 mm ²
		gray	2009-182 100 (4x25)

TOPJOB® S

Double-Deck Terminal Blocks 1 (1.5) mm²

2000 Series

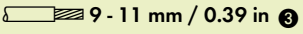
0.14 - 1 (1.5) mm² ① | AWG 24 - 16
 800 V/8 kV/3 ②
 I_N 13.5 A (16 A)
 Terminal block width 4.2 mm / 0.165 in

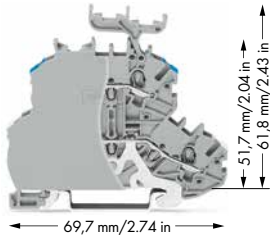

- ① Conductor sizes: 0.14 mm² - 1.5 mm² "s + f-st";
 Push-in conductor sizes: 0.5 mm² - 1.5 mm² "s"
 and 0.5 mm² - 0.75 mm²
 "insulated ferrule, 10 mm"
- ② 800 V = rated voltage
 8 kV = rated surge voltage
 3 = pollution degree
 (see Full Line Catalog, Volume 1, Section 14)
- ③ Strip length, see packaging or instructions.

Item No.	Pack. Unit	2000 Series Accessories	
Ground conductor/through terminal block, with end plate, with marker carrier,		Appropriate marking systems: WMB/Marking strips (see Full Line Catalog, Volume 1, Section 13)	
gray housing		End and intermediate plate, 0.7 mm thick	Test plug adapter,
○ Shield/N	2000-2248/099-000 50	orange 2000-2292 25	for 4 mm Ø test plug
○ Shield/L	2000-2258/099-000 50	gray 2000-2291 25	gray 2009-174 100 (4x25)
Ground conductor/through terminal block, with end plate, without marker carrier,		Push-in type jumper bar, insulated,	Testing tap,
gray housing		I _N 18 A,	for max. 2.5 mm ²
○ Shield/N	2000-2218/099-000 50	light gray	gray 2009-182 100 (4x25)
○ Shield/L	2000-2228/099-000 50	2-way 2001-402 200 (8x25)	Banana plug,
		3-way 2001-403 200 (8x25)	for socket 4 mm Ø,
		4-way 2001-404 200 (8x25)	color mixed
		5-way 2001-405 100 (4x25)	215-111 50
		6-way 2001-406 100 (4x25)	WMB Inline, plain,
		7-way 2001-407 100 (4x25)	stretchable 4 - 4.2 mm,
		8-way 2001-408 100 (4x25)	2,000 WMB markers, 4 mm, on roll
		9-way 2001-409 100 (4x25)	white 2009-114 1
		10-way 2001-410 100 (4x25)	WMB Multi marking system,
Push-in type jumper bar, insulated,		I _N 18 A,	10 strips with 10 markers per card,
		light gray	stretchable 4 - 4.2 mm
		from 1 to 3 2001-433 200 (8x25)	plain 793-4501 5
		from 1 to 4 2001-434 200 (8x25)	WMB Multi marking system, plain,
		from 1 to 5 2001-435 100 (4x25)	10 strips with 10 markers per card,
		from 1 to 6 2001-436 100 (4x25)	stretchable 4 - 4.2 mm
		from 1 to 7 2001-437 100 (4x25)	yellow 793-4501/000-002
		from 1 to 8 2001-438 100 (4x25)	red 793-4501/000-005
		from 1 to 9 2001-439 100 (4x25)	blue 793-4501/000-006
		from 1 to 10 2001-440 100 (4x25)	gray 793-4501/000-007
Protective warning marker,		with high-voltage symbol, black,	orange 793-4501/000-012
		for 5 terminal blocks	light green 793-4501/000-017
		yellow 2001-115 100 (4x25)	green 793-4501/000-023
Double-deck marker carrier,			violet 793-4501/000-024
		pivoting	5
		gray 2000-121 50 (2x25)	
Marking strip, plain,			
		11 mm wide,	
		50 m roll	
		white 2009-110 1	

0.25 - 2.5 (4) mm² ① | AWG 22 - 12
800 V/8 kV/3 ②
I_N 24 A (28 A)
Terminal block width 5.2 mm / 0.205 in
10 - 12 mm / 0.43 in ③

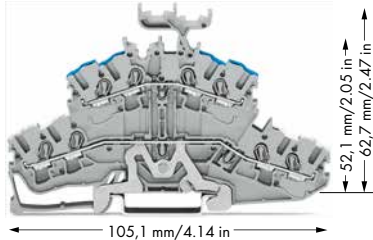

- ① Conductor sizes: 0.25 mm² - 4 mm² "s + f-st"; Push-in conductor sizes: 0.75 mm² - 4 mm² "s" and 0.75 mm² - 2.5 mm² "insulated ferrule, 1.2 mm"
- ② 800 V = rated voltage
8 kV = rated surge voltage
3 = pollution degree
(see Full Line Catalog, Volume 1, Section 14)
- ③ Strip length, see packaging or instructions.
- ④ See application notes in Full Line Catalog, Volume 1, for:
Colored push-in type jumper bars, page 139
Vertical jumper, page 142

Item No.	Pack. Unit	2002 Series Accessories	
Shield conductor/through terminal block, with marker carrier,		Appropriate marking systems: WMB/Marking strips/WMB Inline (see Full Line Catalog, Volume 1, Section 13)	
gray housing		End and intermediate plate, 0.8 mm thick	Test plug adapter,
○ Shield/N	2002-2448	orange	for 4 mm Ø test plug
○ Shield/L	2002-2458	gray	gray
Shield conductor/through terminal block, without marker carrier,		Double-deck marker carrier,	Banana plug,
gray housing		pivoting	for socket 4 mm Ø,
○ Shield/N	2002-2418	gray	color mixed
○ Shield/L	2002-2428		215-111
		Insulation stop,	Testing tap,
		5 pcs/strip,	for max. 2.5 mm ²
		0.25 - 0.5 mm ²	gray
		light gray	2002-171
			200 (8x25)
		Insulation stop,	WMB Multi marking system,
		5 pcs/strip,	10 strips with 10 markers per card,
		0.75 - 1 mm ²	stretchable 5 - 5.2 mm
		dark gray	plain
		2002-172	793-5501
		200 (8x25)	5
		Push-in type jumper bar, insulated,	WMB Multi marking system, plain,
		I _N 25 A,	10 strips with 10 markers per card,
		light gray	stretchable 5 - 5.2 mm
		2-way	yellow
		2002-402	793-5501/000-002
		200 (8x25)	red
		3-way	793-5501/000-005
		2002-403	200 (8x25)
		4-way	blue
		2002-404	793-5501/000-006
		200 (8x25)	gray
		5-way	793-5501/000-007
		2002-405	100 (4x25)
		6-way	793-5501/000-012
		2002-406	100 (4x25)
		7-way	793-5501/000-017
		2002-407	100 (4x25)
		8-way	793-5501/000-023
		2002-408	100 (4x25)
		9-way	793-5501/000-024
		2002-409	100 (4x25)
		10-way	2002-410
		100 (4x25)	5
		Push-in type jumper bar, insulated,	WMB Inline, plain,
		I _N 25 A,	stretchable 5 - 5.2 mm,
		light gray	1,500 WMB markers, 5 mm, on roll
		from 1 to 3	white
		2002-433	2009-115
		200 (8x25)	1
		from 1 to 4	Marking strip, plain,
		2002-434	11 mm wide,
		200 (8x25)	50 m roll
		from 1 to 5	white
		2002-435	2009-110
		100 (4x25)	1
		from 1 to 6	TOPJOB®S group marker carrier,
		2002-437	snap-on type for jumper slot,
		100 (4x25)	5 mm wide
		from 1 to 7	gray
		2002-438	2009-191
		100 (4x25)	50 (2x25)
		from 1 to 8	
		2002-439	
		100 (4x25)	
		from 1 to 9	
		2002-440	
		100 (4x25)	
		from 1 to 10	
		Double-deck vertical jumper, insulated,	
		I _N 24 A	
		light gray	
		2002-492	
		100 (4x25)	
		orange	
		2002-492/000-012	
		Protective warning marker,	
		with high-voltage symbol, black,	
		for 5 terminal blocks	
		yellow	
		2002-115	
		100 (4x25)	

Pluggable Diode Modules on Carrier Terminal Blocks 2.5 (4) mm², 2002 Series







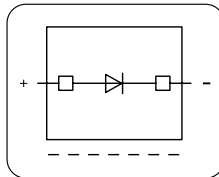

Diode module
with 1N4007 diode
U_N 250 V, U_{RM} 1000 V
I_N 1 A
Plug width 5.2 mm / 0.205 in







- 1 Conductor sizes: 0.5 mm² - 10 mm² "s + f-st";
Push-in conductor sizes: 1 mm² - 10 mm² "s"
and 1.5 mm² - 6 mm²
"insulated ferrule, 12 mm"
- 2 Conductor sizes: 0.5 mm² - 16 mm² "s + f-st";
Push-in conductor sizes: 2.5 mm² - 16 mm² "s"
and 2.5 mm² - 10 mm²
"insulated ferrule, 18 mm"
- 3 Conductor sizes: 0.5 mm² - 16 mm² "s + f-st",
25 mm² "f-st";
Push-in conductor sizes: 2.5 mm² - 16 mm² "s"
and 2.5 mm² - 16 mm²
"insulated ferrule, 18 mm"
- 4 Suitable for Ex e II applications
- 5 Strip length, see packaging or instructions.



- 1 Length of 2002-1661: 66.5 mm / 2.62 in
2-conductor carrier terminal block
- 2 Length of 2002-1861: 87.5 mm / 3.45 in
4-conductor carrier terminal block
- 3 Length of 2002-1961: 72.9 mm / 2.87 in
2-conductor carrier terminal block with additional
jumper position
- 4 See application notes in Full Line Catalog, Volume 1,
for:
Colored push-in type jumper bars, page 139
Staggered jumper, page 141
Push-in type wire jumper, page 140

Item No.	Pack. Unit
Diode module, with 1N4007 diode, max. operating temperature: 85°C, 5.2 mm wide	
○ gray	2002-800/1000-410 100
Carrier Term. Blocks and Accessories Appropriate marking system: WMB/Marking strips	
2-conductor carrier terminal block,	
1 	0.25 - 2.5 (4) mm ² / AWG 22 - 12 Terminal block width 5.2 mm / 0.205 in gray 2002-1661 50
End and intermediate plate, 1 mm thick	
	orange 2002-1692 100 (4x25) gray 2002-1691 100 (4x25)
4-conductor carrier terminal block,	
2 	0.25 - 2.5 (4) mm ² / AWG 22 - 12 Terminal block width 5.2 mm / 0.205 in gray 2002-1861 50
End and intermediate plate, 1 mm thick	
	orange 2002-1892 100 (4x25) gray 2002-1891 100 (4x25)
2-conductor carrier terminal block,	
3 	0.25 - 2.5 (4) mm ² / AWG 22 - 12 Terminal block width 5.2 mm / 0.205 in gray 2002-1961 50
End and intermediate plate, 1 mm thick	
	orange 2002-1992 100 (4x25) gray 2002-1991 100 (4x25)
Insulation stop,	
	5 pcs/strip, 0.25 - 0.5 mm ² light gray 2002-171 200 (8x25)
Insulation stop,	
	5 pcs/strip, 0.75 - 1 mm ² dark gray 2002-172 200 (8x25)

Accessories			
Push-in type wire jumper,			
4 	insulated, I _N 18 A, wire size 1.5 mm ²		
	L = 60 mm	2009-412	100 (10x10)
	L = 110 mm	2009-414	100 (10x10)
	L = 250 mm	2009-416	100 (10x10)
Push-in type jumper bar, insulated,			
4 	I _N 25 A, light gray		
	2-way	2002-402	200 (8x25)
	3-way	2002-403	200 (8x25)
	4-way	2002-404	200 (8x25)
	5-way	2002-405	100 (4x25)
	6-way	2002-406	100 (4x25)
	7-way	2002-407	100 (4x25)
	8-way	2002-408	100 (4x25)
	9-way	2002-409	100 (4x25)
	10-way	2002-410	100 (4x25)
Push-in type jumper bar, insulated,			
	I _N 25 A, light gray		
	from 1 to 3	2002-433	200 (8x25)
	from 1 to 4	2002-434	200 (8x25)
	from 1 to 5	2002-435	100 (4x25)
	from 1 to 6	2002-436	100 (4x25)
	from 1 to 7	2002-437	100 (4x25)
	from 1 to 8	2002-438	100 (4x25)
	from 1 to 9	2002-439	100 (4x25)
	from 1 to 10	2002-440	100 (4x25)
Staggered jumper,			
4 	insulated, I _N 25 A, light gray		
	2-way	2002-472	100 (4x25)
	3-way	2002-473	100 (4x25)
	4-way	2002-474	100 (4x25)
	5-way	2002-475	50 (2x25)
	6-way	2002-476	50 (2x25)
	7-way	2002-477	50 (2x25)
	8-way	2002-478	50 (2x25)
	9-way	2002-479	50 (2x25)
	10-way	2002-480	50 (2x25)
	11-way	2002-481	50 (2x25)
	12-way	2002-482	50 (2x25)

TOPJOB®

Multilevel Installation Terminal Blocks 2.5 (4) mm² 2003 Series

0.25 - 2.5 (4) mm² ① | AWG 22 - 12
 250 V/4 kV/3; 20 A (25 A) ② ③
 400 V/6 kV/3; 20 A (25 A) ② ④
 Terminal block width 5.2 mm / 0.205 in
 10 - 12 mm / 0.43 in ⑤

0.25 - 2.5 (4) mm² ① | AWG 22 - 12
 400 V/6 kV/3 ②
 I_N 24 A (28 A)
 Terminal block width 5.2 mm / 0.205 in
 10 - 12 mm / 0.43 in ⑤

0.25 - 2.5 (4) mm² ① | AWG 22 - 12
 250 V/4 kV/3; 24 A (28 A) ② ③
 400 V/6 kV/3; 24 A (28 A) ② ④
 Terminal block width 5.2 mm / 0.205 in
 10 - 12 mm / 0.43 in ⑤

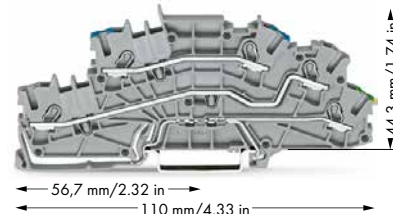
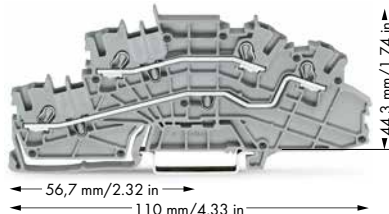
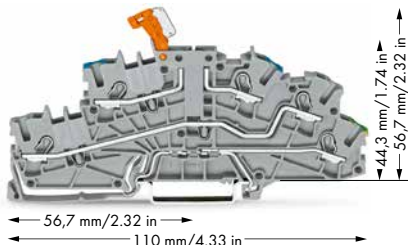

Item No.	Pack. Unit	Item No.	Pack. Unit	Item No.	Pack. Unit
Multilevel installation terminal block, with movable knife disconnect, gray		Multilevel installation terminal block, gray		Multilevel installation terminal block, gray	
○ NTi/L/PE 2003-6641	50	○ L/L 2003-6642	50	○ N/L/PE 2003-6646	50
○ LTi/L/PE 2003-6644	50	○ N/L 2003-6649	50	○ L/L/PE 2003-6645	50
Item-Specific Accessories					
Test plug adapter N/L, for vertical test slot, gray 2-pole 2003-499 100 (4x25)					
Test plug adapter N, for vertical test slot, gray 1-pole 2003-500 100 (4x25)					

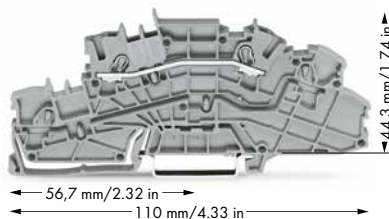
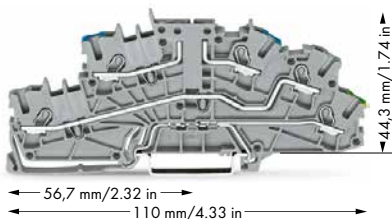

Item No.	Pack. Unit	Item No.	Pack. Unit
Multilevel installation terminal block, I_N 10 A carrier terminal block without knife disconnect, gray Maximum current depends on accessories used.		Multilevel installation terminal block, gray	
○ N/L/PE 2003-6640	50	○ L 2003-6650	50
		○ N 2003-6651	50
Black upper-deck, brown middle-deck, green-yellow lower-deck printing			
○ P2/P1/PE 2003-6643	50		
Brown upper-deck, black middle-deck, green-yellow lower-deck printing			
○ P1/P2/PE 2003-6660	50		
Item-Specific Accessories			
Fuse plug with pull-tab, for miniature metric fuses 5 x 20 mm, nominal voltage and current are given by the fuse gray 2004-911 50			
End and intermediate plate, only for use with fuse plugs, 1 mm thick orange 2003-6693 100 (4x25)			



Multilevel installation terminal block (2003-6641) with N/L test plug adapter (2003-499) for insulation resistance measurement with connected N and L potentials

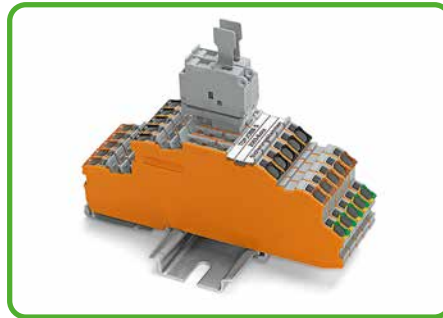

In combination with the 1 mm thick end and intermediate plate (2003-6693), the single fuse holder (2004-911) can also be used with the carrier terminal blocks (2003-6640 and 2003-6643).

- ❶ Conductor sizes: 0.25 mm² - 4 mm² "s + f-st";
Push-in conductor sizes: 0.75 mm² - 4 mm² "s"
and 0.75 mm² - 2.5 mm²
"insulated ferrules, 12 mm"
- ❷ 250 V/
400 V = rated voltage
4 kV/
6 kV = rated surge voltage
3 = pollution degree
(see Full Line Catalog, Volume 1, Section 14)
- ❸ 250 V/4 kV potential-ground
- ❹ 400 V/6 kV potential-potential
- ❺ Strip length, see packaging or instructions.

Accessories Multilevel Installation Terminal Block

Push-in type jumper bars and staggered jumpers, see 2002 Series

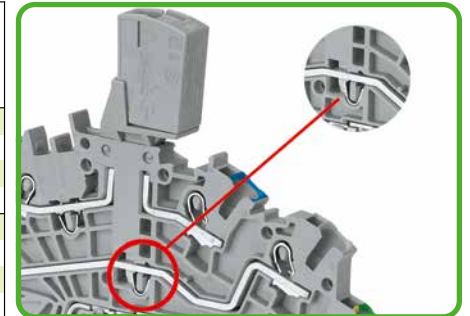

Multilevel installation terminal block (2003-6640) with N/L test plug adapter (2003-499) for insulation resistance measurement with connected N and L potentials

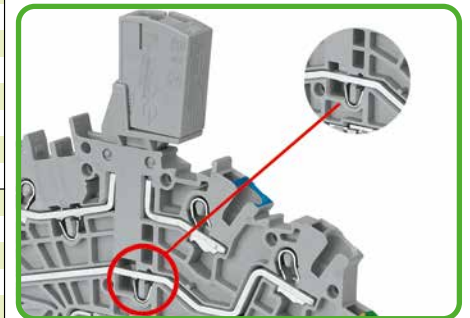

Multilevel installation terminal block (2003-6640) with N test plug adapter (2003-500) for insulation resistance measurement of N potential

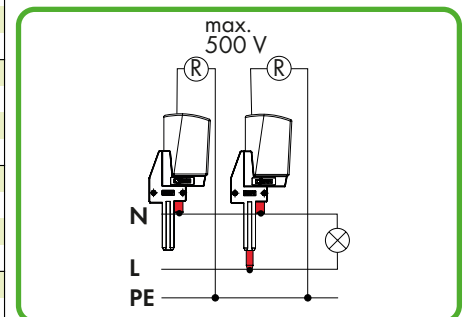

End and intermediate plate, for use without fuse plug, 0.8 mm thick orange 2003-6692 100 (4x25)	Insulation stop, 5 pcs/strip, 0.25 - 0.5 mm ² light gray 2002-171 200 (8x25)
Adjacent jumper for continuous commoning, insulated, I _N 25 A, light gray 2-way 2002-400 100 (4x25)	Insulation stop, 5 pcs/strip, 0.75 - 1 mm ² dark gray 2002-172 200 (8x25)
Busbar carrier, not suitable as end stop, for DIN 35 rail, 1.5 mm thick blue 2009-304 100 (4x25)	Staggered jumper, insulated, I _N 25 A, light gray 2-way 2002-472 100 (4x25) 3-way 2002-473 100 (4x25) 4-way 2002-474 100 (4x25) 5-way 2002-475 50 (2x25) 6-way 2002-476 50 (2x25) 7-way 2002-477 50 (2x25) 8-way 2002-478 50 (2x25) 9-way 2002-479 50 (2x25) 10-way 2002-480 50 (2x25) 11-way 2002-481 50 (2x25) 12-way 2002-482 50 (2x25)
Busbar carrier, can replace end bracket, with detachable separator plate, for DIN 35 rail, 7.5 mm thick blue 2009-305 25	Push-in type wire jumper, insulated, I _N 18 A, wire size 1.5 mm ² L = 60 mm 2009-412 100 (10x10) L = 110 mm 2009-414 100 (10x10) L = 250 mm 2009-416 100 (10x10)
Push-in type jumper bar, insulated, I _N 25 A, light gray 2-way 2002-402 200 (8x25) 3-way 2002-403 200 (8x25) 4-way 2002-404 200 (8x25) 5-way 2002-405 100 (4x25) 6-way 2002-406 100 (4x25) 7-way 2002-407 100 (4x25) 8-way 2002-408 100 (4x25) 9-way 2002-409 100 (4x25) 10-way 2002-410 100 (4x25)	WMB Multi marking system, 10 strips with 10 markers per card, stretchable 5 - 5.2 mm plain 793-5501 5
Push-in type jumper bar, insulated, I _N 25 A, light gray from 1 to 3 2002-433 200 (8x25) from 1 to 4 2002-434 200 (8x25) from 1 to 5 2002-435 100 (4x25) from 1 to 6 2002-436 100 (4x25) from 1 to 7 2002-437 100 (4x25) from 1 to 8 2002-438 100 (4x25) from 1 to 9 2002-439 100 (4x25) from 1 to 10 2002-440 100 (4x25)	WMB Inline, plain, stretchable 5 - 5.2 mm, 1,500 WMB markers, 5 mm, on roll white 2009-115 1
Operating tool, 3.5 mm and 2.5 mm blade, for TOPJOB®S installation terminal blocks 2009-309 50	Marking strip, plain, 11 mm wide, 50 m roll white 2009-110 1
Operating tool, 3.5 mm and 5.5 mm blade, for TOPJOB®S installation terminal blocks 2009-310 50	Operating tool, 3.5 mm and 5.5 mm blade, for TOPJOB®S installation terminal blocks 2009-310 50

TOPJOB®

2003 Series Double Fuse Plugs on 2002 Series Carrier Terminal Blocks

Double fuse plug for miniature metric fuses 5 x 20 mm
250 V / I_N 6 A
Plug width 10.4 mm / 0.409 in

Double fuse plug for miniature metric fuses 5 x 20 mm
250 V / I_N 6 A
Plug width 10.4 mm / 0.409 in

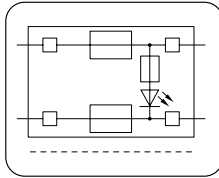
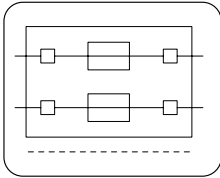

Accessories

WMB Multi marking system,
10 strips with 10 markers per card,
stretchable 5 - 5.2 mm
plain **793-5501** 5

WMB Multi marking system, plain,
10 strips with 10 markers per card,
stretchable 5 - 5.2 mm
yellow **793-5501/000-002**
red **793-5501/000-005**
blue **793-5501/000-006**
gray **793-5501/000-007**
orange **793-5501/000-012**
light green **793-5501/000-017**
green **793-5501/000-023**
violet **793-5501/000-024** 5

Item No.	Pack. Unit	Item No.	Pack. Unit
Double fuse plug, for miniature metric fuses 5 x 20 mm Both nominal voltage and current are given by the fuse.		Double fuse plug, for miniature metric fuses 5 x 20 mm, with indicator lamp, gray Both nominal voltage and current are given by the LED or fuse. Leakage current in case of blown fuse: LED 2mA	
○ gray 2003-911	25	○ 12 - 30 V 2003-911/1000-923	25

Accessories

Appropriate marking systems: WMB/Marking strips
(see Full Line Catalog, Volume 1, Section 13)

2-conductor carrier terminal block, ① 0.25 - 2.5 (4) mm ² / AWG 22 - 12 Terminal block width 5.2 mm / 0.205 in gray 2002-1661 50	Double-deck carrier terminal block, 0.25 - 2.5 (4) mm ² / AWG 22 - 12 Terminal block width 5.2 mm / 0.205 in L/L 2002-2961 50
End and intermediate plate, 1 mm thick orange 2002-1692 100 (4x25) gray 2002-1691 100 (4x25)	Double-deck carrier terminal block, 0.25 - 2.5 (4) mm ² / AWG 22 - 12 Terminal block width 5.2 mm / 0.205 in L/N 2002-2963 50
4-conductor carrier terminal block, ② 0.25 - 2.5 (4) mm ² / AWG 22 - 12 Terminal block width 5.2 mm / 0.205 in gray 2002-1861 50	End and intermediate plate, 1 mm thick orange 2002-2992 100 (4x25) gray 2002-2991 100 (4x25)
End and intermediate plate, 1 mm thick orange 2002-1892 100 (4x25) gray 2002-1891 100 (4x25)	End plate for fuse terminal blocks, 2 mm thick orange 2002-992 100 (4x25) gray 2002-991 100 (4x25)
2-conductor carrier terminal block, ③ 0.25 - 2.5 (4) mm ² / AWG 22 - 12 Terminal block width 5.2 mm / 0.205 in gray 2002-1961 50	Shorting link, 5 x 20 mm, if the fuse plug is used as disconnect plug I _N 6.3 A 250 (10x25) 281-503
End and intermediate plate, 1 mm thick orange 2002-1992 100 (4x25) gray 2002-1991 100 (4x25)	

1 TOPJOB® Colored Push-In Type Jumper Bars 2000 Series

Volume 1

Push-in type jumper bar

Push-in type jumper bar



Item No.	Pack. Unit	Item No.	Pack. Unit
Push-in type jumper bar, insulated, In 14 A, red		Push-in type jumper bar, insulated, In 14 A, blue	
● 2-way	2000-402/000-005	● 2-way	2000-402/000-006
● 3-way	2000-403/000-005	● 3-way	2000-403/000-006
● 4-way	2000-404/000-005	● 4-way	2000-404/000-006
	200 (8x25)		200 (8x25)
● 5-way	2000-405/000-005	● 5-way	2000-405/000-006
● 6-way	2000-406/000-005	● 6-way	2000-406/000-006
● 7-way	2000-407/000-005	● 7-way	2000-407/000-006
● 8-way	2000-408/000-005	● 8-way	2000-408/000-006
● 9-way	2000-409/000-005	● 9-way	2000-409/000-006
● 10-way	2000-410/000-005	● 10-way	2000-410/000-006
	100 (4x25)		100 (4x25)

TOPJOB®

Double-Deck Carrier Terminal Blocks

2.5 (4) mm², 2002 Series

0.25 - 2.5 (4) mm² ① AWG 22 - 12
 400 V/6 kV/3 ②
 I_N 16 A
 Terminal block width 5.2 mm / 0.205 in
 10 - 12 mm / 0.43 in ③

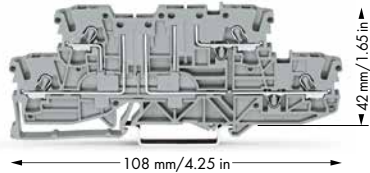

- ① Conductor sizes: 0.25 mm² - 4 mm² "s + f-st";
 Push-in conductor sizes: 0.75 mm² - 4 mm² "s"
 and 0.75 mm² - 2.5 mm²
 "insulated ferrules, 12 mm"
- ② 400 V = rated voltage
 6 kV = rated surge voltage
 3 = pollution degree
 (see Full Line Catalog, Volume 1, Section 14)
- ③ Strip length, see packaging or instructions.
- ④ See application notes in Full Line Catalog, Volume 1,
 for:
 Colored push-in type jumper bars, page 139
 Push-in type wire jumper, page 140



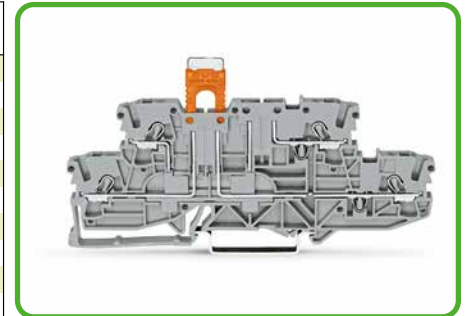





Item No.	Pack. Unit
Double-deck carrier terminal Block, same profile as double-deck, double-disconnect terminal block, gray housing	
○ L/L 2002-2941	50
Double-deck carrier terminal Block, same profile as double-deck, double-disconnect terminal block, blue housing	
● N/N 2002-2944	50



Carrier terminal block (2002-2941) with disconnect plug (2002-401) in parked position.

2002 Series Accessories

Appropriate marking systems: WMB/Marking strips
 (see Section 13)

End and intermediate plate, 1 mm thick  orange 2002-2992 100 (4x25)  gray 2002-2991 100 (4x25)	Push-in type jumper bar, insulated,  I _N 25 A, light gray from 1 to 3 2002-433 200 (8x25) from 1 to 4 2002-434 200 (8x25) from 1 to 5 2002-435 100 (4x25) from 1 to 6 2002-436 100 (4x25) from 1 to 7 2002-437 100 (4x25)
Insulation stop,  5 pcs/strip, 0.25 - 0.5 mm ² light gray 2002-171 200 (8x25)	from 1 to 8 2002-438 100 (4x25) from 1 to 9 2002-439 100 (4x25) from 1 to 10 2002-440 100 (4x25)
Insulation stop,  5 pcs/strip, 0.75 - 1 mm ² dark gray 2002-172 200 (8x25)	Protective warning marker, with high-voltage symbol, black, for 5 terminal blocks  yellow 2002-115 100 (4x25)
Push-in type jumper bar, insulated, ④ I _N 25 A, light gray 2-way 2002-402 200 (8x25) 3-way 2002-403 200 (8x25) 4-way 2002-404 200 (8x25) 5-way 2002-405 100 (4x25) 6-way 2002-406 100 (4x25) 7-way 2002-407 100 (4x25) 8-way 2002-408 100 (4x25) 9-way 2002-409 100 (4x25) 10-way 2002-410 100 (4x25)	WMB Multi marking system,  10 strips with 10 markers per card, stretchable 5 - 5.2 mm plain 793-5501 5
Push-in type wire jumper, ④ insulated, I _N 18 A, wire size 1.5 mm ² L = 60 mm 2009-412 100 (10x10) L = 110 mm 2009-414 100 (10x10) L = 250 mm 2009-416 100 (10x10)	WMB Multi marking system, plain,  10 strips with 10 markers per card, stretchable 5 - 5.2 mm yellow 793-5501/000-002 red 793-5501/000-005 blue 793-5501/000-006 gray 793-5501/000-007 orange 793-5501/000-012 light green 793-5501/000-017 green 793-5501/000-023 violet 793-5501/000-024

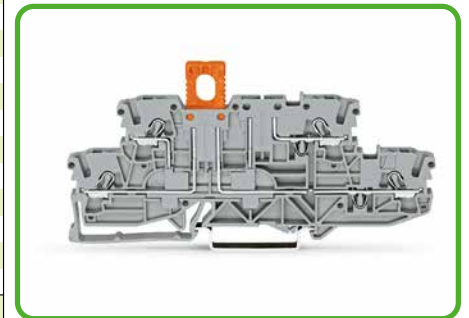

Carrier terminal block (2002-2941) with disconnect plug (2002-401) in operating position.

TOPJOB®

Double-Deck Terminal Blocks 2.5 (4) mm²

2002 Series

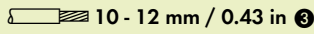
0.25 - 2.5 (4) mm² ① | AWG 22 - 12
 500 V/6 kV/3 ②
 I_N 24 A (28 A)
 Terminal block width 5.2 mm / 0.205 in
 10 - 12 mm / 0.43 in ③

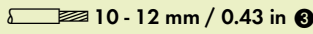
0.25 - 2.5 (4) mm² ① | AWG 22 - 12
 500 V/6 kV/3 ②
 I_N 24 A (28 A)
 Terminal block width 5.2 mm / 0.205 in
 10 - 12 mm / 0.43 in ③

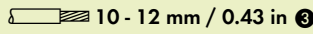
0.25 - 2.5 (4) mm² ① | AWG 22 - 12
 500 V/6 kV/3 ②
 I_N 24 A (28 A)
 Terminal block width 5.2 mm / 0.205 in
 10 - 12 mm / 0.43 in ③

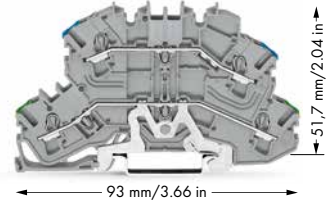
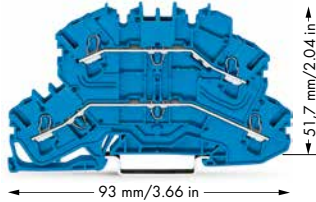
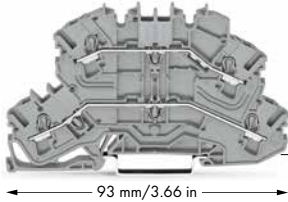

Item No.	Pack. Unit	Item No.	Pack. Unit	Item No.	Pack. Unit
Through/through terminal block, same profile as double-deck disconnect terminal block without marker carrier, gray housing ○ L/L 2002-2601 50 ○ N/L 2002-2602 50 ○ L/N 2002-2603 50		Through/through terminal block, same profile as double-deck disconnect terminal block without marker carrier, blue housing ● N/N 2002-2604 ④ 50		Ground conductor/through terminal block, same profile as double-deck disconnect terminal block without marker carrier, gray housing ○ PE/N 2002-2647 50 ○ PE/L 2002-2657 50	
Other terminal blocks with the same profile: Carrier 2002-2661 Page 16 Disconnect 2002-2671 Page 16 Fuse 2002-2611 Page 17					

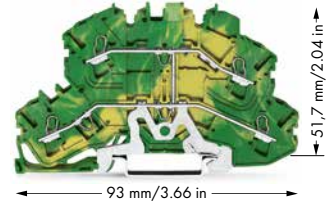
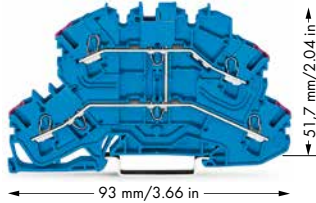
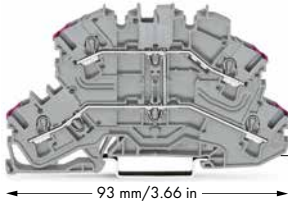

Item No.	Pack. Unit	Item No.	Pack. Unit	Item No.	Pack. Unit
4-conductor through terminal block, same profile as double-deck disconnect terminal block, without marker carrier, internal commoning, conductor entry position colored in violet, gray housing ○ L 2002-2608 50		4-conductor through terminal block, same profile as double-deck disconnect terminal block, without marker carrier, internal commoning, conductor entry position colored in violet, blue housing ● N 2002-2609 ④ 50		Through/through terminal block, same profile as double-deck disconnect terminal block without marker carrier, internal commoning, green-yellow housing ● PE 2002-2607 50	

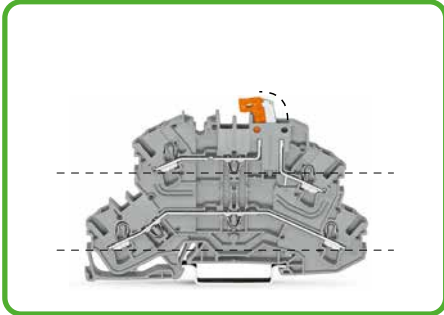

Multifunctional terminal blocks:
The double-deck disconnect terminal block with movable knife disconnect (2002-2671) can be used as through terminal block on the lower deck and as disconnect terminal block on the upper deck.

Besides disconnection and measurement, the **2002-2667 double-deck carrier terminal block** also provides ground conductor functionality.

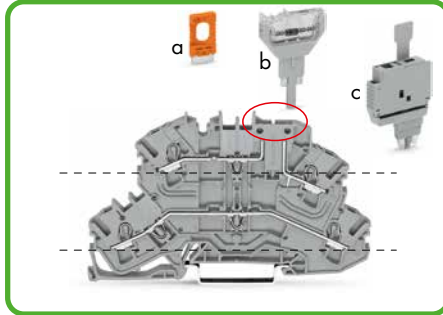

The associated **carrier terminal block (2002-2661)** has the same design as the disconnect terminal block. However, disconnect plugs (a: 2002-401), pluggable diode (b: 2002-800/1000-411) and LED modules (not shown here, 2002-800/1000-541) or fuse plugs (c: 2004-911) can alternatively be used here.

- ① Conductor sizes: 0.25 mm² - 4 mm² "s + f-st";
Push-in conductor sizes: 0.75 mm² - 4 mm² "s"
and 0.75 mm² - 2.5 mm²
"insulated ferrule, 12 mm"
- ② 500 V = rated voltage
6 kV = rated surge voltage
3 = pollution degree
(see Full Line Catalog, Volume 1, Section 14)
- ③ Strip length, see packaging or instructions.
- ④ Suitable for Ex i applications
- ⑤ See application notes in Full Line Catalog, Volume 1, for:
Colored push-in type jumper bars, page 139
Vertical jumper, page 142



The **double-deck fuse disconnect terminal block with pivoting fuse holder (2002-2611, gray)** is compatible with disconnect, carrier, through and ground conductor terminal blocks. The fuse holder is also available with a blown fuse LED indicator.
(e.g., 2002-2611/1000-541 for 12-30 V)





An **end plate for fuse terminal blocks (shown in orange, 2002-1092)** is used for additional protection, preventing the fuse shaft from being opened. The fuse cannot be replaced until disconnecting the fuse holder from the power supply.

2002 Series Accessories

Appropriate marking systems: WMB/Marking strips/WMB Inline

End and intermediate plate,			
1 mm thick			
	orange	2002-2692	100 (4x25)
	gray	2002-2691	100 (4x25)

Double-deck marker carrier,			
pivoting			
	gray	2002-121	50 (2x25)

Insulation stop,			
5 pcs/strip,			
0.25 - 0.5 mm ²			
	light gray	2002-171	200 (8x25)

Insulation stop,			
5 pcs/strip,			
0.75 - 1 mm ²			
	dark gray	2002-172	200 (8x25)

Push-in type jumper bar, insulated,			
	In 25 A, light gray		
	2-way	2002-402	200 (8x25)
	3-way	2002-403	200 (8x25)
	4-way	2002-404	200 (8x25)
	5-way	2002-405	100 (4x25)
	6-way	2002-406	100 (4x25)
	7-way	2002-407	100 (4x25)
	8-way	2002-408	100 (4x25)
	9-way	2002-409	100 (4x25)
	10-way	2002-410	100 (4x25)

Push-in type jumper bar, insulated,			
	In 25 A, light gray		
	from 1 to 3	2002-433	200 (8x25)
	from 1 to 4	2002-434	200 (8x25)
	from 1 to 5	2002-435	100 (4x25)
	from 1 to 6	2002-436	100 (4x25)
	from 1 to 7	2002-437	100 (4x25)
	from 1 to 8	2002-438	100 (4x25)
	from 1 to 9	2002-439	100 (4x25)
	from 1 to 10	2002-440	100 (4x25)

Double-deck vertical jumper, insulated,			
	In 24 A, light gray	2002-492	100 (4x25)
	orange	2002-492/000-012	

Adjacent jumper for continuous commoning, insulated,			
	In 25 A, light gray		
	2-way	2002-400	100 (4x25)

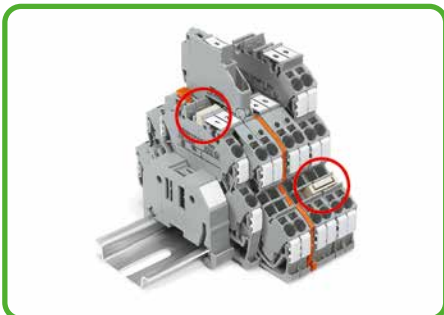

Same profile allows for commoning with TOPJOB® S double-deck terminal blocks (upper deck) and with triple-deck terminal blocks (lower deck).

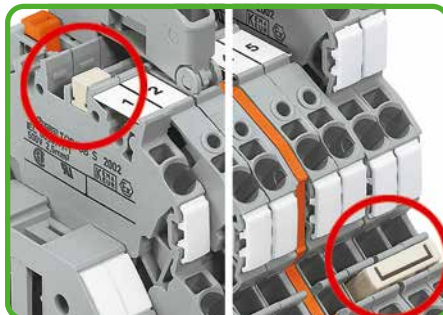

Left picture - Vertical jumper (2002-492)
Right picture - Push-in type jumper bar for 2002 Series

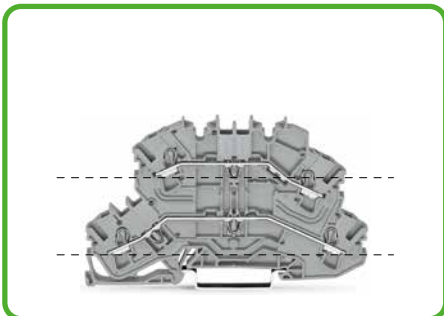

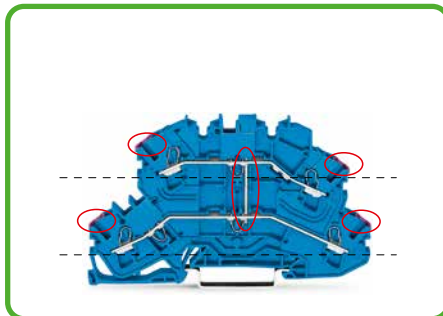

The **through terminal block (2002-2601)** features two independent current bars on both lower and upper deck, sharing the same profile as the disconnect terminal block. Commoning is also possible for these terminal blocks using the double-deck vertical jumper (2002-492).



The **4-conductor through terminal block (2002-2609)** with internal commoning can be immediately identified via violet-colored conductor entry.

Double-Deck Fuse Disconnect Terminal Blocks with Pivoting Fuse Holder 2.5 (4) mm², 2002 Series

<p>0.25 - 2.5 (4) mm² ① AWG 22 - 12 250 V/6 kV/3 ② I_N 6.3 A</p> <p>Terminal block width 6.2 mm / 0.244 in  10 - 12 mm / 0.43 in ③</p>	<p>0.25 - 2.5 (4) mm² ① AWG 22 - 12 250 V/6 kV/3 ② I_N 6.3 A</p> <p>Terminal block width 6.2 mm / 0.244 in  10 - 12 mm / 0.43 in ③</p>
---	---

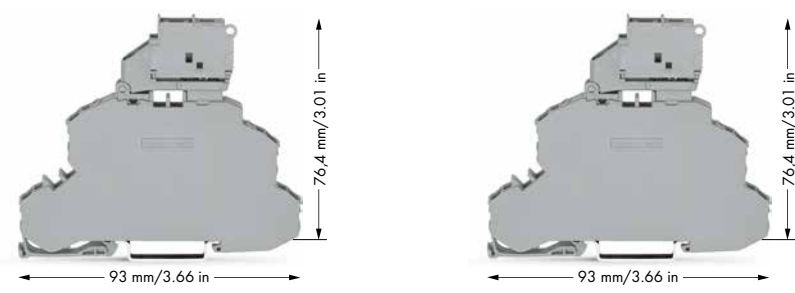

- ① Conductor sizes: 0.25 mm² - 4 mm² "s + f-st"; Push-in conductor sizes: 0.75 mm² - 4 mm² "s" and 0.75 mm² - 2.5 mm² "insulated ferrule, 1.2 mm"
- ② 250 V = rated voltage
 6 kV = rated surge voltage
 3 = pollution degree
 (see Full Line Catalog, Volume 1, Section 14)
- ③ Strip length, see packaging or instructions.
- ④ See application notes in Full Line Catalog, Volume 1, for:
 Vertical jumper, page 142
- ⑤ Protective warning marker and insulation stop must be applied individually.
- ⑥ Due to the 6.2 mm width of fuse terminal blocks with pivoting fuse holder, 2004 Series jumpers must be used.



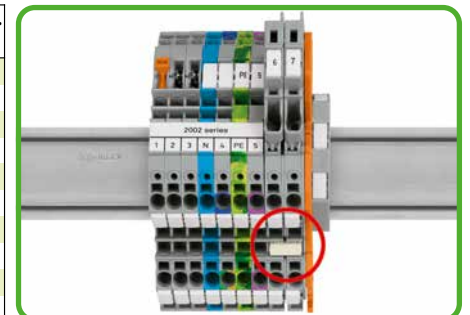

Item No.	Pack. Unit	Item No.	Pack. Unit		
Double-deck fuse disconnect terminal block with pivoting fuse holder, Through/fuse terminal block, for miniature metric fuses 5 x 20 mm, without blown fuse indication Nominal voltage and current are given by the fuse.		Double-deck fuse disconnect terminal block with pivoting fuse holder, Through/fuse terminal block, with blown fuse indication by LED, gray Nominal voltage and current are given by the LED or fuse. Leakage current in case of blown fuse: LED 2mA			
○ L/L	2002-2611	25	○ 12 - 30 V	2002-2611/1000-541	25
○ N/L	2002-2612	25	○ 30 - 65 V	2002-2611/1000-542	25
			○ 230 V	2002-2611/1000-836	25



A spacer plate is supplied with all 6.2 mm wide fuse terminal blocks. Due to the 6.2 mm width of fuse terminal blocks with pivoting fuse holder, 2004 Series jumpers must be used.

2002 Series Accessories

Appropriate marking systems: WMB/Marking strips
 (see Full Line Catalog, Volume 1, Section 13)

End and intermediate plate, 1 mm thick  orange 2002-2692 100 (4x25)  gray 2002-2691 100 (4x25)	End plate for fuse terminal blocks, 2 mm thick  orange 2002-1092 100 (4x25)  gray 2002-1091 100 (4x25)
Push-in type jumper bar, insulated, I _N 32 A, light gray ④ ⑥ 2-way 2004-402 200 (8x25) 3-way 2004-403 200 (8x25) 4-way 2004-404 100 (4x25) 5-way 2004-405 100 (4x25) 6-way 2004-406 100 (4x25) 7-way 2004-407 100 (4x25) 8-way 2004-408 100 (4x25) 9-way 2004-409 100 (4x25) 10-way 2004-410 100 (4x25)	Insulation stop, ⑤ 5 pcs/strip, 0.25 - 0.5 mm ² light gray 2002-171 200 (8x25) Insulation stop, 5 pcs/strip, 0.75 - 1 mm ² dark gray 2002-172 200 (8x25)
Push-in type jumper bar, insulated, I _N 32 A, light gray from 1 to 3 2004-433 200 (8x25) from 1 to 4 2004-434 200 (8x25) from 1 to 5 2004-435 100 (4x25) from 1 to 6 2004-436 100 (4x25) from 1 to 7 2004-437 100 (4x25) from 1 to 8 2004-438 100 (4x25) from 1 to 9 2004-439 100 (4x25) from 1 to 10 2004-440 100 (4x25)	Protective warning marker, ⑤ with high-voltage symbol, black, for 5 terminal blocks yellow 2002-115 100 (4x25)
Push-in type jumper bar, insulated, I _N 24 A light gray 2002-492 100 (4x25) orange 2002-492/000-012	Test plug, with 500 mm cable, 2 mm Ø red 210-136 50 Test plug, with 500 mm cable, 2.3 mm Ø yellow 210-137 50 Marking strip, plain, 11 mm wide, 50 m roll white 2009-110 1

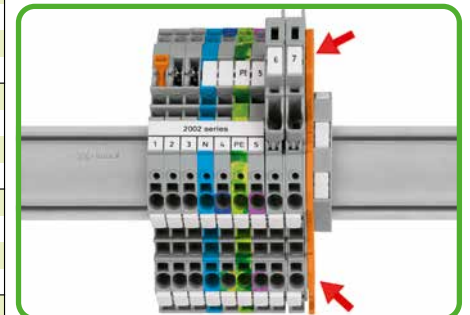

Additionally, an end plate for fuse terminal blocks (e.g., 2002-1092, orange) must be used at the end of an assembly or if there is no adjacent fuse terminal block.

TOPJOB®

Disconnect Terminal Blocks for Test and Measurement, Through Terminal Blocks of Same Profile 2.5 (4) mm², 2002 Series

<p>0.25 - 2.5 (4) mm² ① AWG 22 - 12 400 V/6 kV/3 ② I_N 16 A</p> <p>Terminal block width 5.2 mm / 0.205 in 10 - 12 mm / 0.43 in ③</p>	<p>0.25 - 2.5 (4) mm² ① AWG 22 - 12 400 V/6 kV/3 ② I_N 16 A</p> <p>Terminal block width 5.2 mm / 0.205 in 10 - 12 mm / 0.43 in ③</p>	<p>0.25 - 2.5 (4) mm² ① AWG 22 - 12 400 V/6 kV/3 ② I_N 16 A</p> <p>Terminal block width 5.2 mm / 0.205 in 10 - 12 mm / 0.43 in ③</p>
---	---	---

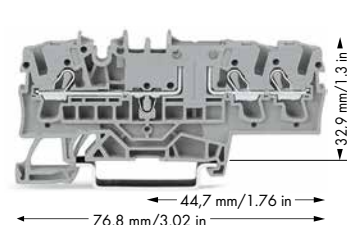
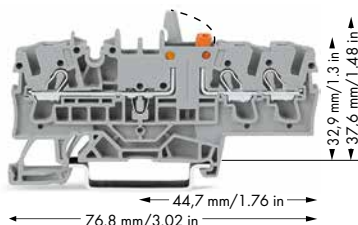
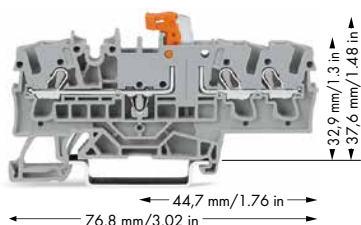

Item No.	Pack. Unit	Item No.	Pack. Unit	Item No.	Pack. Unit
3-conductor disconnect terminal block for test and measurement, with test point, orange disconnect link		3-conductor disconnect terminal block for test and measurement with mechanical interlock, with test point, orange disconnect link		3-conductor through terminal block, with test point, same profile as 3-conductor disconnect terminal block	
gray 2002-1771	50	gray 2002-1771/401-000	50	gray 2002-1701	50
blue 2002-1774	50	blue 2002-1774/401-000	50	blue 2002-1704	50
orange 2002-1772	50	orange 2002-1772/401-000	50	orange 2002-1702	50
				2-conductor ground terminal block	
				green-yellow 2002-1707	50
				Other terminal blocks with the same profile:	
				Carrier 2002-1761	Page 23
				Fuse 2002-1781	Page 23

2002 Series Accessories

Appropriate marking systems: WMB/Marking strips/WMB Inline (see Full Line Catalog, Volume 1, Section 13)



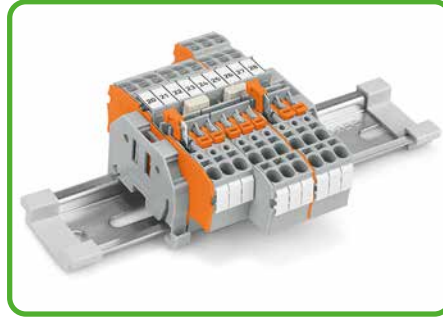



<p>End and intermediate plate, 1 mm thick</p> <p>orange 2002-1792 100 (4x25)</p> <p>gray 2002-1791 100 (4x25)</p>	<p>Push-in type jumper bar, insulated,</p> <p>I_N 25 A, light gray</p> <p>from 1 to 3 2002-433 200 (8x25)</p> <p>from 1 to 4 2002-434 200 (8x25)</p> <p>from 1 to 5 2002-435 100 (4x25)</p> <p>from 1 to 6 2002-436 100 (4x25)</p> <p>from 1 to 7 2002-437 100 (4x25)</p> <p>from 1 to 8 2002-438 100 (4x25)</p> <p>from 1 to 9 2002-439 100 (4x25)</p> <p>from 1 to 10 2002-440 100 (4x25)</p>	<p>Customized staggered jumper,</p> <p>insulated, I_N 25 A, light gray</p> <p>1-3 2002-473/011-000 100 (4x25)</p> <p>1-3-5 2002-475/011-000 100 (4x25)</p> <p>1-3-5-7 2002-477/011-000 100 (4x25)</p> <p>1-3-5-7-9 2002-479/011-000 100 (4x25)</p> <p>1-3-5-7-9-11 2002-481/011-000 50 (2x25)</p>
<p>Insulation stop,</p> <p>5 pcs/strip, 0.25 - 0.5 mm² light gray 2002-171 200 (8x25)</p>		
<p>Insulation stop,</p> <p>5 pcs/strip, 0.75 - 1 mm² dark gray 2002-172 200 (8x25)</p>		
<p>Push-in type jumper bar, insulated,</p> <p>I_N 25 A, light gray</p> <p>2-way 2002-402 200 (8x25)</p> <p>3-way 2002-403 200 (8x25)</p> <p>4-way 2002-404 200 (8x25)</p> <p>5-way 2002-405 100 (4x25)</p> <p>6-way 2002-406 100 (4x25)</p> <p>7-way 2002-407 100 (4x25)</p> <p>8-way 2002-408 100 (4x25)</p> <p>9-way 2002-409 100 (4x25)</p> <p>10-way 2002-410 100 (4x25)</p>	<p>Staggered jumper,</p> <p>insulated, I_N 25 A, light gray</p> <p>2-way 2002-472 100 (4x25)</p> <p>3-way 2002-473 100 (4x25)</p> <p>4-way 2002-474 100 (4x25)</p> <p>5-way 2002-475 50 (2x25)</p> <p>6-way 2002-476 50 (2x25)</p> <p>7-way 2002-477 50 (2x25)</p> <p>8-way 2002-478 50 (2x25)</p> <p>9-way 2002-479 50 (2x25)</p> <p>10-way 2002-480 50 (2x25)</p> <p>11-way 2002-481 50 (2x25)</p> <p>12-way 2002-482 50 (2x25)</p>	<p>Protective warning marker,</p> <p>with high-voltage symbol, black, for 5 terminal blocks</p> <p>yellow 2002-115 100 (4x25)</p>
<p>Push-in type wire jumper,</p> <p>insulated, I_N 18 A, wire size 1.5 mm²</p> <p>L = 60 mm 2009-412 100 (10x10)</p> <p>L = 110 mm 2009-414 100 (10x10)</p> <p>L = 250 mm 2009-416 100 (10x10)</p>	<p>Adjacent jumper for continuous commoning, insulated,</p> <p>I_N 25 A, light gray</p> <p>2-way 2002-400 100 (4x25)</p>	<p>Testing tap,</p> <p>for max. 2.5 mm² gray 2009-182 100 (4x25)</p>
		<p>Test plug adapter,</p> <p>for 4 mm Ø test plug gray 2009-174 100 (4x25)</p>
		<p>Banana plug,</p> <p>for socket 4 mm Ø, color mixed</p> <p>215-111 50</p>
		<p>TOPJOB®S L-test plug module,</p> <p>can be snapped together gray 2002-611 100 (4x25)</p>



One center and two side marker slots for WMB markers or marking strips. Dual jumper slots, in the same position as the 2002 Series terminal blocks. Commoning options in front of or behind the knife disconnect, depending on the power supply direction.

- ❶ Conductor sizes: 0.25 mm² - 4 mm² "s + f-st";
Push-in conductor sizes: 0.75 mm² - 4 mm² "s"
and 0.75 mm² - 2.5 mm² "insulated ferrules, 12 mm"
- ❷ 400 V = rated voltage
6 kV = rated surge voltage
3 = pollution degree
(see Full Line Catalog, Volume 1, Section 14)
- ❸ Strip length, see packaging or instructions.
- ❹ See application notes in Full Line Catalog, Volume 1, for:
Colored push-in type jumper bars, page 139
Staggered jumper, page 141
Adjacent jumper for continuous commoning, page 139
Push-in type wire jumper, page 140
TOPJOB®S connector, page 134
TOPJOB®S L-type test plug module, page 136

Accessories

Modular TOPJOB®S connector,			
❹		can be snapped together, for jumper contact slot gray	2002-511 100 (4x25)
Spacer module, can be snapped together, e.g., for bridging commoned terminal blocks			
		gray	2002-549 100 (4x25)
End plate, for modular TOPJOB®S connectors, 1.5 mm thick			
		gray	2002-541 100 (4x25)
Double-deck marker carrier, pivoting			
		gray	2002-121 50 (2x25)
WMB Multi marking system, 10 strips with 10 markers per card, stretchable 5 - 5.2 mm			
		plain	793-5501 5
WMB Inline, plain, stretchable 5 - 5.2 mm, 1,500 WMB markers, 5 mm, on roll			
		white	2009-115 1
Marking strip, plain, 11 mm wide, 50 m roll			
		white	2009-110 1

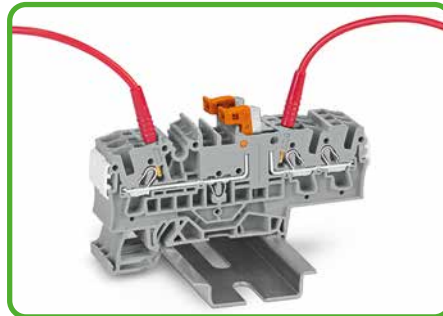

Testing with test plug 2 mm Ø

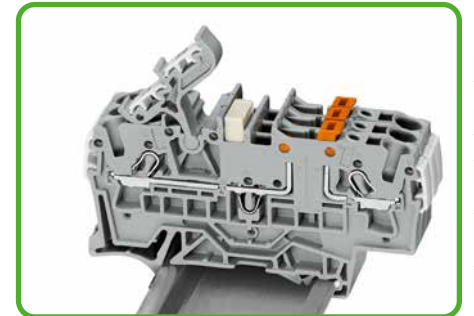

Additional marking option via pivoting marking adapter



2- and 4-conductor disconnect terminal blocks for test und measurement
Opening the knife disconnect.

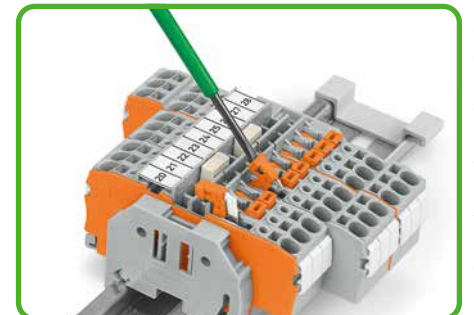

2- and 4-conductor disconnect terminal blocks for test and measurement
Closing the knife disconnect.





Carrier terminal block with disconnect plug in operating position.



Carrier terminal block with disconnect plug in parked position.

Fuse Disconnect Terminal Blocks with Pivoting Fuse Holder 2.5 (4) mm² for Miniature Metric Fuses 5 x 20 mm, 2002 Series

Volume 1

<p>0.25 - 2.5 (4) mm² ① AWG 22 - 12 250 V/6 kV/3 ② 250 V, 6 A^{VA} I_N 6.3 A 250 V, 6 A[Ⓒ]</p> <p>Terminal block width 6.2 mm / 0.244 in  10 - 12 mm / 0.43 in ③</p>	<p>0.25 - 2.5 (4) mm² ① AWG 22 - 12 250 V/6 kV/3 ② 250 V, 6 A^{VA} I_N 6.3 A 250 V, 6 A[Ⓒ]</p> <p>Terminal block width 6.2 mm / 0.244 in  10 - 12 mm / 0.43 in ③</p>
---	--

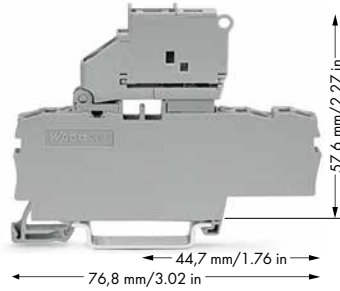
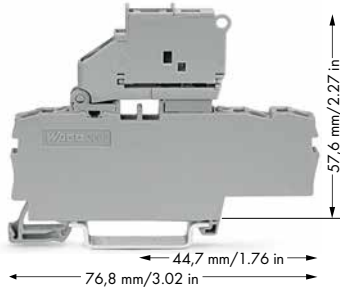



- ① Conductor sizes: 0.25 mm² - 4 mm² "s + f-st";
 Push-in conductor sizes: 0.75 mm² - 4 mm² "s"
 and 0.75 mm² - 2.5 mm²
 "insulated ferrule, 12 mm"
- ② 250 V = rated voltage
 6 kV = rated surge voltage
 3 = pollution degree
 (see Full Line Catalog, Volume 1, Section 14)
- ③ Strip length, see packaging or instructions.
- ④ See application notes in Full Line Catalog, Volume 1, for:
 Push-in type wire jumper, page 140

Item No.	Pack. Unit	Item No.	Pack. Unit
3-conductor fuse disconnect terminal block with pivoting fuse holder, for miniature metric fuses 5 x 20 mm, without blown fuse indication Both nominal voltage and current are given by the fuse.		3-conductor fuse disconnect terminal block with pivoting fuse holder, for miniature metric fuses 5 x 20 mm, with blown fuse indication by LED, gray Both nominal voltage and current are given by the LED or fuse. Leakage current in case of blown fuse: LED 2mA	
○ gray	2002-1711 50	○ 12 - 30 V	2002-1711/1000-541 50
		○ 30 - 65 V	2002-1711/1000-542 50
		○ 230 V	2002-1711/1000-836 50
		○ 120 V	2002-1711/1000-867 50

Accessories

Appropriate marking systems: WMB/Marking strips
 (see Full Line Catalog, Volume 1, Section 13)

End plate for fuse terminal blocks,	Push-in type jumper bar, insulated,	Push-in type jumper bar, insulated,
 2 mm thick orange 2002-992 100 (4x25) gray 2002-991 100 (4x25)	 I _N 32 A, light gray 2-way 2004-402 200 (8x25) 3-way 2004-403 200 (8x25) 4-way 2004-404 100 (4x25) 5-way 2004-405 100 (4x25) 6-way 2004-406 100 (4x25) 7-way 2004-407 100 (4x25) 8-way 2004-408 100 (4x25) 9-way 2004-409 100 (4x25) 10-way 2004-410 100 (4x25)	 I _N 32 A, light gray from 1 to 3 2004-433 200 (8x25) from 1 to 4 2004-434 200 (8x25) from 1 to 5 2004-435 100 (4x25) from 1 to 6 2004-436 100 (4x25) from 1 to 7 2004-437 100 (4x25) from 1 to 8 2004-438 100 (4x25) from 1 to 9 2004-439 100 (4x25) from 1 to 10 2004-440 100 (4x25)
Insulation stop, 5 pcs/strip, 0.25 - 0.5 mm ² light gray 2002-171 200 (8x25)		
Insulation stop, 5 pcs/strip, 0.75 - 1 mm ² dark gray 2002-172 200 (8x25)		
Push-in type wire jumper, insulated, I _N 16 A, wire size 1.5 mm ² L = 60 mm 2009-412 100 (10x10) L = 110 mm 2009-414 100 (10x10) L = 250 mm 2009-416 100 (10x10)	Protective warning marker, with high-voltage symbol, black, for 5 terminal blocks yellow 2002-115 100 (4x25)	

<p>0.25 - 2.5 (4) mm² ① AWG 22 - 12 400 V/6 kV/3 ② I_N 10 A ③</p> <p>Terminal block width 5.2 mm / 0.205 in 10 - 12 mm / 0.43 in ④</p>	<p>300 V, 10 A ⑤ 300 V, 10 A ⑥</p>	<p>0.25 - 2.5 (4) mm² ① AWG 22 - 12 400 V/6 kV/3 ② I_N 6.3 A</p> <p>Terminal block width 5.2 mm / 0.205 in 10 - 12 mm / 0.43 in ④</p>	<p>300 V, 10 A ⑤ 300 V, 10 A ⑥</p>
---	--	--	--

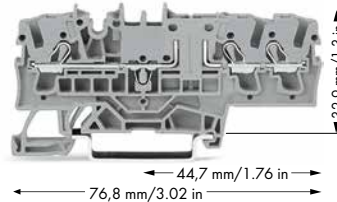
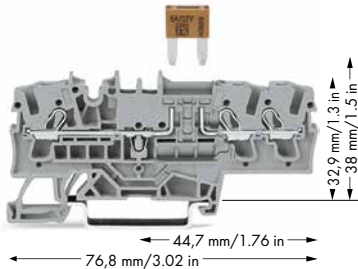

- ① Conductor sizes: 0.25 mm² - 4 mm² "s + f-st"; Push-in conductor sizes: 0.75 mm² - 4 mm² "s" and 0.75 mm² - 2.5 mm² "insulated ferrules, 12 mm"
- ② 400 V = rated voltage
6 kV = rated surge voltage
3 = pollution degree
(see Full Line Catalog, Volume 1, Section 14)
- ③ - Individual arrangement: 10 A
- Block arrangement: 5 A
Protection against direct contact must be observed for 42 V and higher voltages
- ④ Strip length, see packaging or instructions.
- ⑤ See application notes in Full Line Catalog, Volume 1, for:
Colored push-in type jumper bars, page 139
Staggered jumper, page 141
Adjacent jumper for continuous commoning, page 139
Push-in type wire jumper, page 140
TOPJOB®S connector, page 134
TOPJOB®S L-type test plug module, page 136

Item No.	Pack. Unit	Item No.	Pack. Unit	Accessories
3-conductor fuse terminal block, with test point, for blade-style fuses acc. to DIN 72581-3f, ISO 8820-3		3-conductor carrier terminal block		
○ gray 2002-1781	50	○ gray 2002-1761	50	Staggered jumper, ⑤ insulated, I _N 25 A, light gray 2-way 2002-472 100 (4x25) 3-way 2002-473 100 (4x25) 4-way 2002-474 100 (4x25) 5-way 2002-475 50 (2x25) 6-way 2002-476 50 (2x25) 7-way 2002-477 50 (2x25) 8-way 2002-478 50 (2x25) 9-way 2002-479 50 (2x25) 10-way 2002-480 50 (2x25) 11-way 2002-481 50 (2x25) 12-way 2002-482 50 (2x25)
Blade-style fuses are not offered by WAGO				
Other terminal blocks with the same profile: Through 2002-1701 Page 20		Other terminal blocks with the same profile: Through 2002-1701 Page 20		
2002 Series Accessories Appropriate marking systems: WMB/Marking strips/WMB Inline (see Full Line Catalog, Volume 1, Section 13)				
End and intermediate plate, 1 mm thick orange 2002-1792 100 (4x25) gray 2002-1791 100 (4x25)		Adjacent jumper for continuous commoning, insulated, ⑤ I _N 25 A, light gray 2-way 2002-400 100 (4x25)		Modular TOPJOB®S connector, ⑤ can be snapped together, for jumper contact slot gray 2002-511 100 (4x25)
Insulation stop, 5 pcs/strip, 0.25 - 0.5 mm ² light gray 2002-171 200 (8x25)		Push-in type jumper bar, insulated, I _N 25 A, light gray from 1 to 3 2002-433 200 (8x25) from 1 to 4 2002-434 200 (8x25) from 1 to 5 2002-435 100 (4x25) from 1 to 6 2002-436 100 (4x25) from 1 to 7 2002-437 100 (4x25) from 1 to 8 2002-438 100 (4x25) from 1 to 9 2002-439 100 (4x25) from 1 to 10 2002-440 100 (4x25)		Spacer module, can be snapped together, e.g., for bridging commoned terminal blocks gray 2002-549 100 (4x25)
Insulation stop, 5 pcs/strip, 0.75 - 1 mm ² dark gray 2002-172 200 (8x25)		Push-in type wire jumper, ⑤ insulated, I _N 16 A, wire size 1.5 mm ² L = 60 mm 2009-412 100 (10x10) L = 110 mm 2009-414 100 (10x10) L = 250 mm 2009-416 100 (10x10)		End plate, for modular TOPJOB®S connectors, 1.5 mm thick gray 2002-541 100 (4x25)
Push-in type jumper bar, insulated, ⑤ I _N 25 A, light gray 2-way 2002-402 200 (8x25) 3-way 2002-403 200 (8x25) 4-way 2002-404 200 (8x25) 5-way 2002-405 100 (4x25) 6-way 2002-406 100 (4x25) 7-way 2002-407 100 (4x25) 8-way 2002-408 100 (4x25) 9-way 2002-409 100 (4x25) 10-way 2002-410 100 (4x25)		Test plug, with 500 mm cable, 2 mm Ø red 210-136 50		TOPJOB®S L-test plug module, ⑤ can be snapped together gray 2002-611 100 (4x25)
Protective warning marker, with high-voltage symbol, black, for 5 terminal blocks yellow 2002-115 100 (4x25)		Banana plug, for socket 4 mm Ø, color mixed 215-111 50		Test plug adapter, for 4 mm Ø test plug gray 2009-174 100 (4x25)
Double-deck marker carrier, pivoting gray 2002-121 50 (2x25)				Testing tap, for max. 2.5 mm ² gray 2009-182 100 (4x25)
				WMB Multi marking system, 10 strips with 10 markers per card, stretchable 5 - 5.2 mm plain 793-5501 5

TOPJOB® S 2007-8821 Current Transformer Terminal Blocks (Orange Disconnect Link)

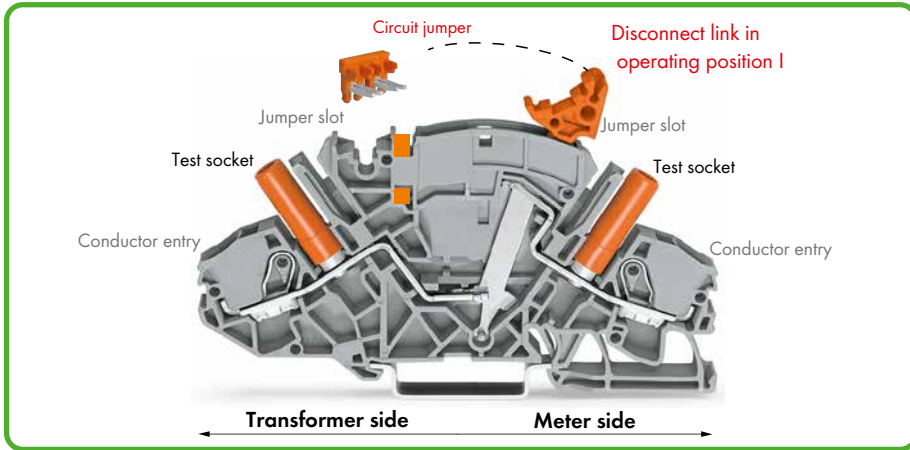

The TOPJOB® S current transformer (disconnect/test) terminal block (2007-8821) has been specially designed for current and voltage transformer circuits to measure the current transformer's operability.

First, the current transformer is shorted via disconnect link and circuit jumper (insert jumper, move disconnect link from operation position I to shorting position II, activate shorting path). Connecting a measuring device via test socket on the meter side can only be performed once circuit disconnection is complete (disconnect link in measuring position III).

- Features top-of-unit circuit jumper slot for shorting path activation.
- Disconnect link provides intuitive and easy operation, as well as exact switching status indication.
- Combines high functionality with compact design (99.6 mm long and 8 mm wide).
- All 2007 Series terminal blocks are rated 30 A/500 V (IEC) and 300 V (UL).
- With a terminal block width of 8 mm, the maximum cross-section for solid and fine-stranded conductors is 10 mm² (AWG 8) and 6 mm² (AWG 10) for ferruled conductors.
- Touch-proof test sockets for 4 mm Ø test plugs on transformer and meter side.
- Compatible with through and ground conductor terminal blocks of same profile.

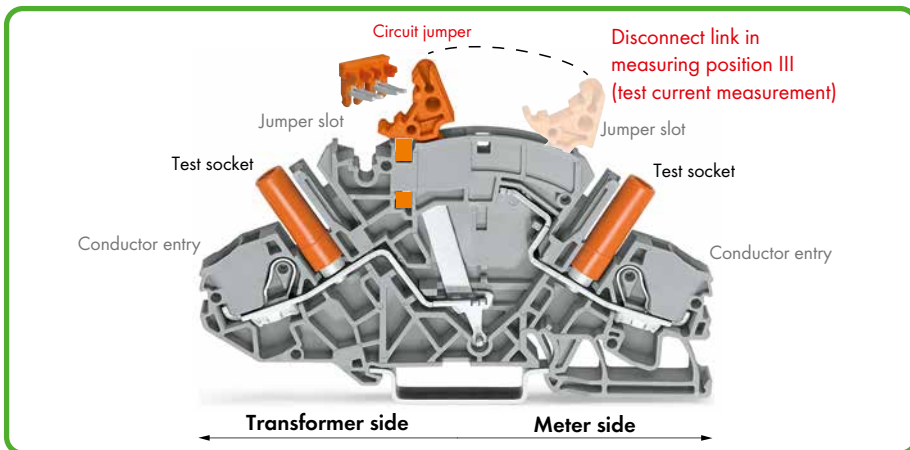
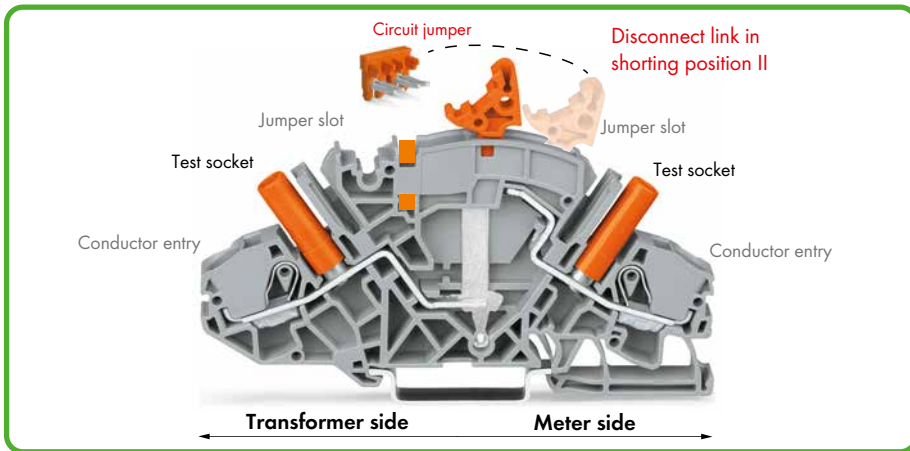

Preparing the shorting path for current transformer circuits
Inserting insulated, touch-proof circuit jumpers into jumper slot. Using locking covers or profiles for adjacent terminal blocks allows disconnect links to be operated simultaneously.



CAGE CLAMP® S
clamps the following
copper conductors:*

solid



stranded



fine-stranded,
also with tinned
single strands

* For aluminum conductors, see notes in Full Line Catalog, Volume 1, Section 14.

Disconnect link in operating position I



Terminal blocks required:
 2 x disconnect/test terminal block 2007-8821
 1 x circuit jumper, orange 2007-8442
 optional with locking covers or interlocking links

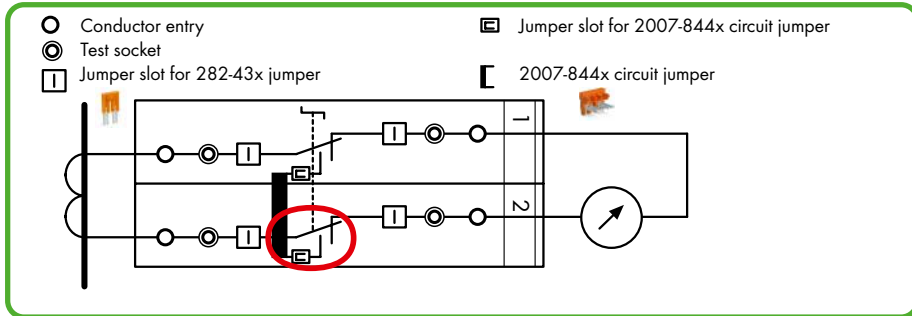

In operating position, the measuring device is connected to the transformer, the circuit jumper is inserted and the disconnect link is in position I.

Disconnect link in shorting position II

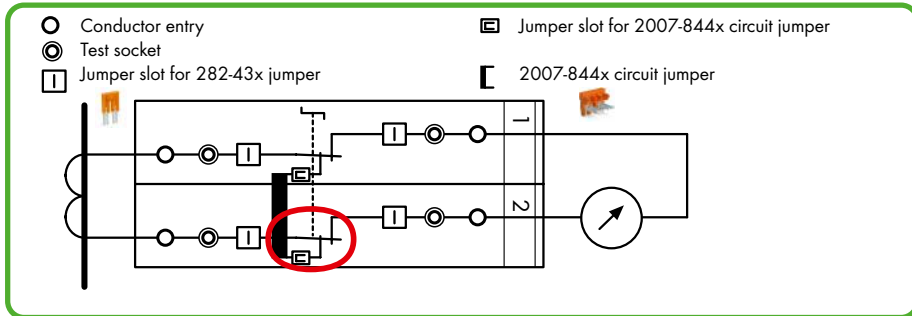

The transformer is **not** disconnected from the measuring device yet, the shorting path is activated by moving the disconnect link into shorting position II and the transformer is safely shorted.

Measuring, disconnect link in measuring position III / test current measurement

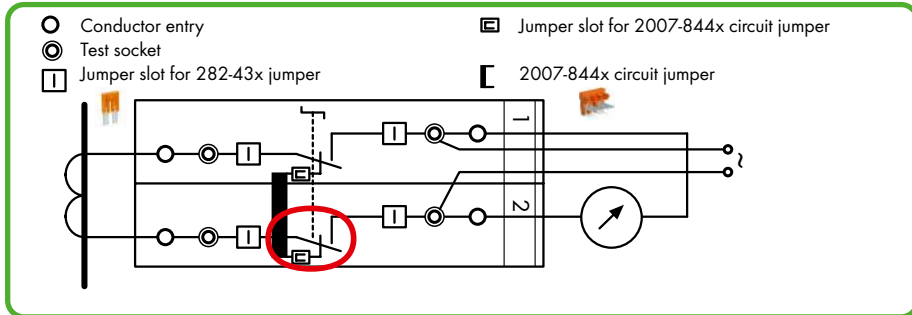

The measuring device/relay is electrically disconnected from the transformer. If required, an external voltage can be applied to the measuring device/relay via the test socket.

Measurement testing via both test sockets



Terminal block 1: Disconnect link in operating position I
 Terminal block 2: Disconnect link in measuring position III

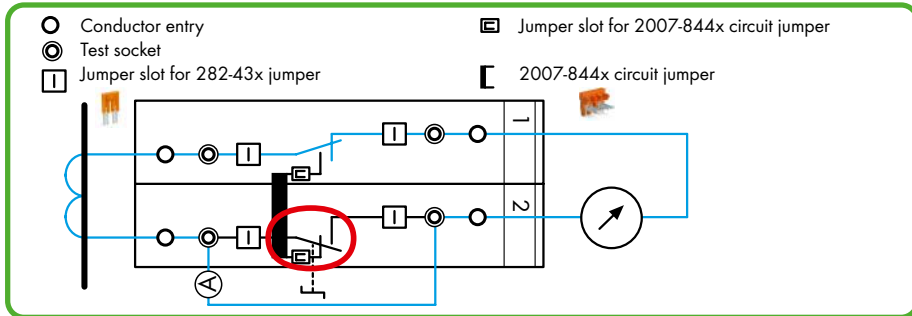

Measurement testing: First insert the reference current meter (A) into the test socket, then move the disconnect link into measurement position III (test current measurement).



fine-stranded, tip-bonded



fine-stranded, with ferrule (gas-tight crimped)



fine-stranded, with pin terminal (gas-tight crimped)

Examples for Current Transformer Circuits

26 Measuring set for a 3-phase current transformer



Terminal blocks required:
 6 x disconnect/test terminal block 2007-8821
 3 x circuit jumper, orange 2007-8442
 In addition: interlocking links, locking covers, lock-outs

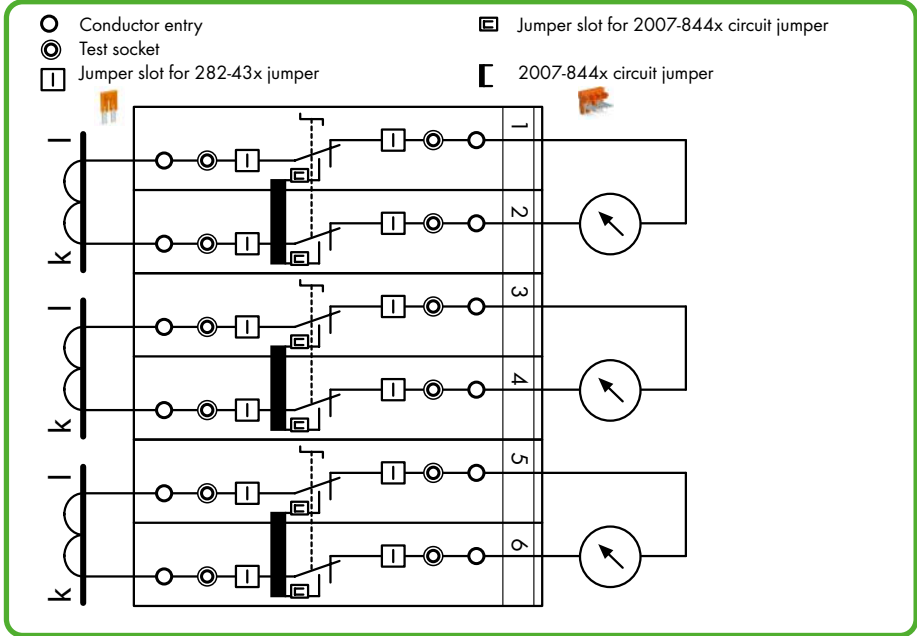

Pairs of disconnect links are interconnected via locking covers or interlocking links. Measurement testing is performed after the interlocking is released.

Measuring set for a 3-phase current transformer with 'Y' point



Terminal blocks required:
 6 x disconnect/test terminal block 2007-8821
 1 x circuit jumper, orange 2007-8446
 1 x jumper, orange 282-433
 In addition: interlocking links, locking covers, lock-outs

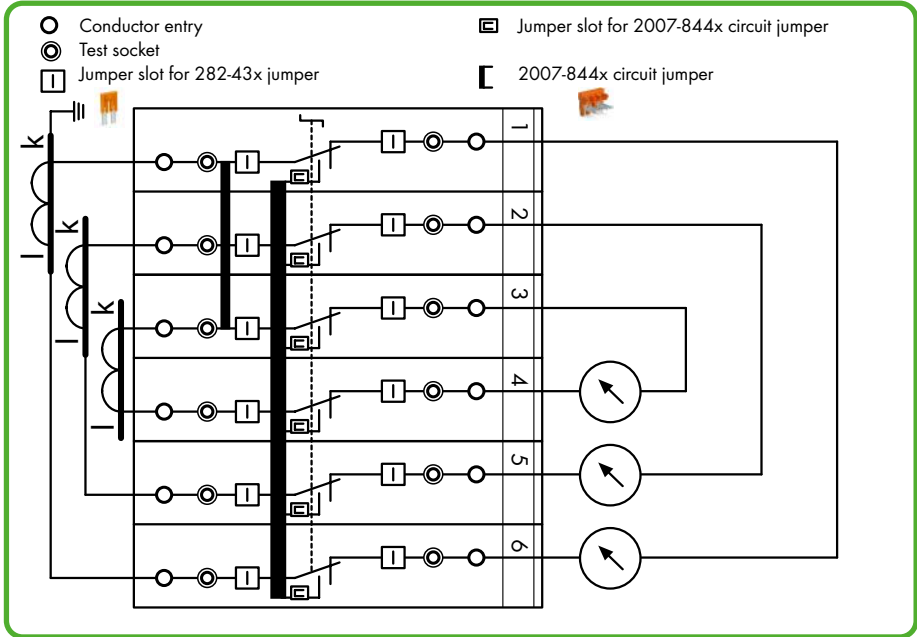

All 6 disconnect links are interconnected via via locking covers or interlocking links.

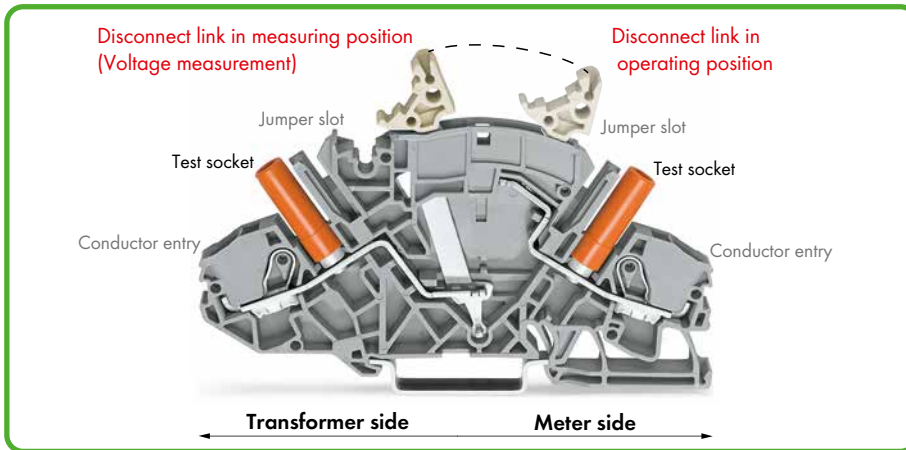

The TOPJOB® S voltage transformer (disconnect/test) terminal block (2007-8811) has been specially designed for voltage transformer circuits.

First, the voltage transformer must be disconnected from the circuit (from operating position to measuring position). Connecting a measuring device via test socket on the meter side can only be performed once circuit disconnection is completed (measuring position).

- For voltage transformer circuits (no circuit jumper slot required as for current transformer terminal block 2007-8821).
- Disconnect link provides intuitive and easy operation, as well as exact switching status indication.
- Combines high functionality with compact design (99.6 mm long and 8 mm wide).
- All 2007 Series terminal blocks are rated at 30 A/500 V (IEC) and 300 V (UL).
- With a terminal block width of 8 mm, the maximum cross-section for solid and fine-stranded conductors is 10 mm² (AWG 8) and 6 mm² (AWG 10) for ferruled conductors.
- Touch-proof test sockets for 4 mm Ø test plugs on transformer and meter side.
- Compatible with through and ground conductor terminal blocks of same profile.

Example for voltage transformer testing
Measuring set for single-phase voltage transformer testing

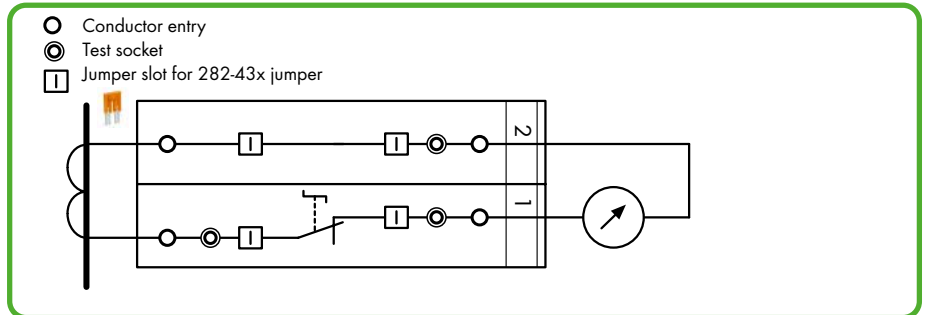

- Terminal blocks required:
 1 x disconnect/test terminal block 2007-8811
 1 x through terminal block 2007-8801
 1 x end plate, orange 2007-8892
 In addition: locking cover, lock-out

Disconnecting the voltage transformer from the circuit: Move disconnect link from operating position to measuring position.
 Voltage measurement: Connecting a measuring device via test socket on the meter side can only be performed after disconnection is completed (measuring position).

Marking



Marking via WMB Multi markers or marking strips.

Commoning



Additional commoning option via circuit-related jumpers or testing via test plug adapters (209-170) on transformer side

Locking cover for disconnect links



Multipole switching via snap-on type, transparent (locking) cover for disconnect links.

Disconnect Terminal Blocks for Test and Measurement, 6 mm²/30 A, for Current and Voltage Transformer Circuits, 2007 Series

0.5 - 6 (10) mm² ① | AWG 20 - 8
500 V/6 kV/3 ②
I_N 30 A

Terminal block width 8 mm / 0.315 in
13 - 15 mm / 0.55 in ③

0.5 - 6 (10) mm² ① | AWG 20 - 8
500 V/6 kV/3 ②
I_N 30 A

Terminal block width 8 mm / 0.315 in
13 - 15 mm / 0.55 in ③

0.5 - 6 (10) mm² ① | AWG 20 - 8
500 V/6 kV/3 ②
I_N 30 A

Terminal block width 8 mm / 0.315 in
13 - 15 mm / 0.55 in ③

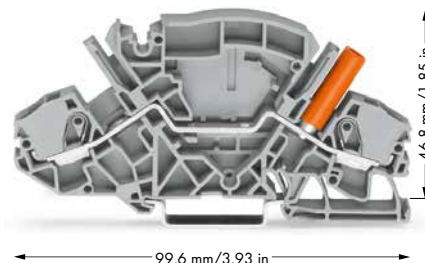
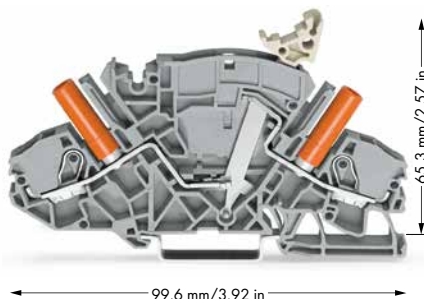
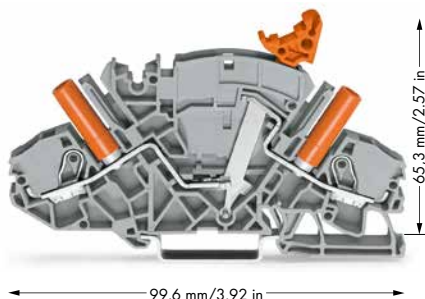

Item No.	Pack. Unit	Item No.	Pack. Unit	Item No.	Pack. Unit
2-conductor disconnect terminal block for test and measurement , e.g., current transformer circuits, with receptacle for adjacent jumper with switch lever, with touch-proof test sockets, for 4 mm Ø test plug		2-conductor disconnect terminal block for test and measurement , e.g., voltage transformer circuits, with touch-proof test sockets, for 4 mm Ø test plug		2-conductor through terminal block , with touch-proof test socket, for 4 mm Ø test plug	
○ gray 2007-8821	20	○ gray 2007-8811	20	○ gray 2007-8801	20
Item-Specific Accessories					
Adjacent jumper for switch lever , insulated, orange, I _N 30 A					
 2-way	2007-8442	50 (5x10)			
3-way	2007-8443	50 (5x10)			
4-way	2007-8444	50 (5x10)			
5-way	2007-8445	50 (5x10)			
6-way	2007-8446	50 (5x10)			
7-way	2007-8447	50 (5x10)			
8-way	2007-8448	50 (5x10)			

2006 Series Accessories

Appropriate marking systems: WMB/Marking strips
(see Full Line Catalog, Volume 1, Section 13)

End and separator plate , 1.5 mm thick, without use of lock-out seal	Jumper , insulated, I _N 30 A, orange	Jumper , special design, I _N 30 A, orange
orange 2007-8892 50 (5x10)	2-way 282-432 50 (5x10)	1-3-5 282-435/011-000
gray 2007-8891 50 (5x10)	3-way 282-433 50 (5x10)	1-2-4-6 282-436/301-000
End and separator plate , 1.5 mm thick, for use of lock-out seal	4-way 282-434 50 (5x10)	1-3-5-7 282-437/011-000
orange 2007-8894 50 (5x10)	5-way 282-435 50 (5x10)	1-4-7 282-437/012-000
gray 2007-8893 50 (5x10)	6-way 282-436 50 (5x10)	1-2-5-8 282-438/300-000
Lock-out , for disconnect link	7-way 282-437 50 (5x10)	1-4-7-8 282-438/301-000
yellow 2007-8899 100 (5x20)	8-way 282-438 50 (5x10)	1-3-5-7-9 282-439/011-000 50 (5x10)
Locking cover , transparent, mechanically locks multiple links	Jumper with safety lid , insulated, I _N 30 A, orange	Protective warning marker , with high-voltage symbol, black, for 5 terminal blocks
1-pole 282-881 50 (5x10)	2-way 282-432/100-000	yellow 2006-115 100 (4x25)
2-pole 282-882 50 (5x10)	3-way 282-433/100-000	WMB Multi marking system , 10 strips with 10 markers per card, for terminal widths 5 - 17.5 mm
3-pole 282-883 50 (5x10)	4-way 282-434/100-000 50 (5x10)	plain 793-501 5
4-pole 282-884 50 (5x10)		Marking strip , plain, 11 mm wide, 50 m roll
5-pole 282-885 50 (5x10)	Interlocking link , mechanically locks multiple links, 1 m/3'3" long	white 2009-110 1
6-pole 282-886 50 (5x10)	transparent 210-254 1	
7-pole 282-887 50 (5x10)		
8-pole 282-888 50 (5x10)		



0.5 - 6 (10) mm² ① | AWG 20 - 8

Terminal block width 8 mm / 0.315 in
 13 - 15 mm / 0.55 in ③



The terminal blocks feature integrated test sockets for touch-proof 4 mm Ø test plugs.

- ① Conductor sizes: 0.5 mm² - 10 mm² "s + f-st";
 Push-in conductor sizes: 1 mm² - 10 mm² "s"
 and 1.5 mm² - 6 mm²
 "insulated ferrule, 12 mm"
- ② 500 V = rated voltage
 6 kV = rated surge voltage
 3 = pollution degree
 (see Full Line Catalog, Volume 1, Section 14)
- ③ Strip length, see packaging or instructions.

Item No.	Pack. Unit
2-conductor ground terminal block, with touch-proof test socket, for 4 mm Ø test plug	
 green-yellow 2007-8807	20
WMB Multi marking system,  10 strips with 10 markers per card, for terminal widths 5 - 17.5 mm, yellow k/1 (50x) 794-5553/000-002	
5	
WMB Multi marking system,  10 strips with 10 markers per card, for terminal widths 5 - 17.5 mm, blue U/V (50x) 794-5554/000-006	
5	



Lock-out prevents accidental operation of disconnect link.



Lock-out snaps into one of two notched positions.



Interlocking link for mechanical interlocking of several links for multi-pole switching



A lock-out seal can be used on the disconnect link in operating position I in connection with end and separator plate (2007-8893 or 2007-8894)

TOPJOB®

Terminal Block Assemblies for Current and Voltage Transformers

2007 Series

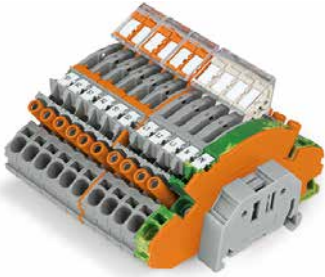

Item No. for 2007-8873	Description	Quantity
249-117	Screwless end stop, 10 mm wide	2
282-882	Locking cover, mechanically locks multiple links, 2-pole	3
282-884	Locking cover, mechanically locks multiple links, 4-pole	1
2007-8442	Adjacent jumper for switch lever, insulated, 2-way	3
2007-8807	2-conductor ground terminal block, with touch-proof test socket, for 4 mm Ø test plug	1
2007-8811	2-conductor disconnect terminal block for test and measurement, with touch-proof test sockets, for 4 mm Ø test plug	4
2007-8821	2-conductor disconnect terminal block for test and measurement, with touch-proof test sockets, for 4 mm Ø test plug	6
2007-8892	End and separator plate, 1.5 mm thick, without use of lock-out seal	2
209-135	WMB Inline, plain, stretchable 5 - 5.2 mm, 8,000 WMB markers, 5 mm, on roll	21 Markers
282-435/011-000	Jumper, insulated, 1-3-5	1
Assembly width incl. end stop		11.2 cm

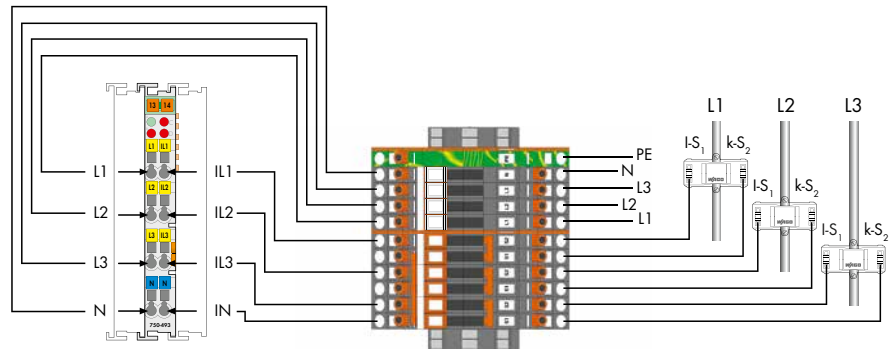

3-Phase Power Measurement Module
750 Series

Terminal Block Assembly for
Current and Voltage Transformers
2007 Series

Current Transformers
855 Series



Item No. for 2007-8876	Quantity
Description	
249-117 Screwless end stop, 10 mm wide	2
282-369 Collective carrier for jumpers, for DIN 35 rail, for jumpers for transverse switching terminal block (282-811) and longitudinal switching disconnect terminal block (282-821)	1
282-882 Locking cover, mechanically locks multiple links, 2-pole	3
2007-8442 Adjacent jumper for switch lever, insulated, 2-way	3
2007-8821 2-conductor disconnect terminal block for test and measurement, with touch-proof test sockets, for 4 mm Ø test plug	6
2007-8892 End and separator plate, 1.5 mm thick, without use of lock-out seal	1
2009-135 WMB Inline, plain, stretchable 5 - 5.2 mm, 8,000 WMB markers, 5 mm, on roll	12 Markers
282-435/011-000 Jumper, insulated, 1-3-5	1
Assembly width incl. end stop	8.5 cm

TOPJOB®

Disconnect Terminal Blocks for Test and Measurement 1500 VDC, Carrier/Through Terminal Blocks of Same Profile 6 (10) mm²/30 A, 2006 Series

0.5 - 6 (10) mm² ① | AWG 20 - 8
AC/DC 1000 V/ DC 1500 V/12 kV/3 ②
I_N 30 A
Terminal block width 15 mm / 0.591 in
13 - 15 mm / 0.55 in ③

0.5 - 6 (10) mm² ① | AWG 20 - 8
AC/DC 1000 V/ DC 1500 V/12 kV/3 ②
I_N 30 A
Terminal block width 15 mm / 0.591 in
13 - 15 mm / 0.55 in ③



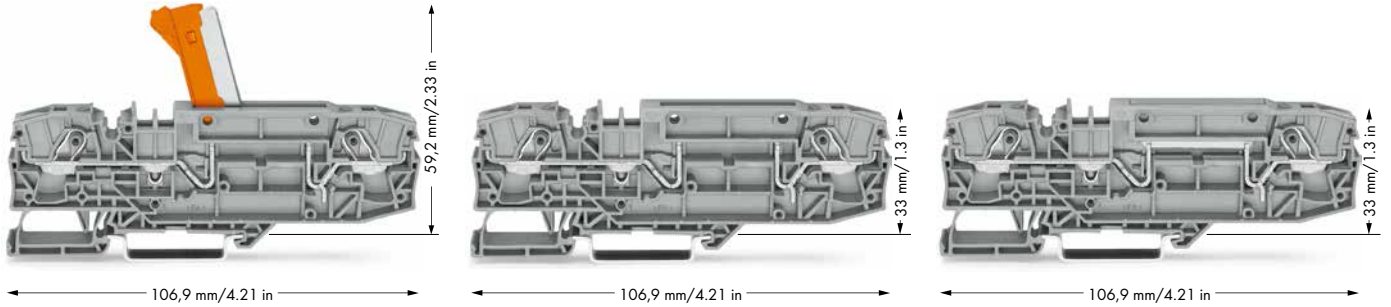





0.5 - 6 (10) mm² ① | AWG 20 - 8
AC/DC 1000 V/ DC 1500 V/12 kV/3 ②
I_N 30 A
Terminal block width 15 mm / 0.591 in
13 - 15 mm / 0.55 in ③

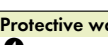

Item No.	Pack. Unit	Item No.	Pack. Unit	Item No.	Pack. Unit
2-conductor disconnect terminal block for test and measurement, with test point, orange disconnect link		2-conductor carrier terminal block, with test point		2-conductor through terminal block, with test point, same profile as 2-conductor disconnect terminal block	
○ gray	2006-8671	12	○ gray	2006-8661	12
● blue	2006-8674	12	● blue	2006-8664	12
Item-Specific Accessories					
 Disconnect plug for carrier terminal blocks, suited when using a carrier terminal block as disconnect terminal block orange 2006-8401 48 (4x12)					

2006 Series Accessories

Appropriate marking systems: WMB/Marking strips
(see Full Line Catalog, Volume 1, Section 13)

End and intermediate plate, 1 mm thick  orange 2006-8692 48 (4x12)  gray 2006-8691 48 (4x12)	WMB Multi marking system,  10 strips with 10 markers per card, for terminal widths 5 - 17.5 mm plain 793-501 5
Protective warning marker, ④ with high-voltage symbol, black, for 5 terminal blocks  yellow 2006-115 100 (4x25)	WMB Multi marking system, plain,  10 strips with 10 markers per card, for terminal widths 5 - 17.5 mm yellow 793-501/000-002 red 793-501/000-005 blue 793-501/000-006 gray 793-501/000-007 orange 793-501/000-012 light green 793-501/000-017 green 793-501/000-023 violet 793-501/000-024 5
Push-in type jumper bar, insulated, I _N 41 A, light gray  from 1 to 3 2006-433 50 (2x25) from 1 to 5 2006-435 50 (2x25)	Marking strip, plain,  11 mm wide, 50 m roll white 2009-110 1
Lockout cap, for conductor entry hole and operating slot  gray 2006-191 25	WMB Inline, plain,  stretchable 5 - 5.2 mm, 1,500 WMB markers, 5 mm, on roll white 2009-115 1

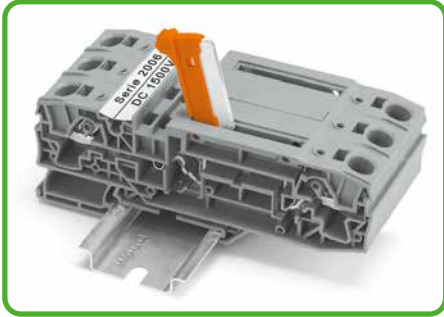

Disconnect/test terminal block with knife disconnect (2006-8671) in disconnect position

Both 2006-8671 and 2006-8661 TOPJOB® S disconnect terminal blocks have been specially designed for use in photovoltaic and wind power systems, where voltages exceeding 1,000 V (IEC) and 600 V (UL) are required (e.g., generator junction boxes).

- Ideal for high voltages in renewable energy applications
- **Disconnect terminal blocks with two alternative disconnect options:**
with orange knife disconnect (2006-8671)
with orange disconnect plug (2006-8661)
- This 2006 Series terminal blocks are approved for 30 A/1,500 VDC (IEC) or 1,000 VDC (UL)
- With a terminal block width of 15 mm, the maximum cross-section for solid and fine-stranded conductors is 10 mm² (AWG 8) and 6 mm² (AWG 10) for ferruled conductors.
- Equipped with test slots
- Compatible with through terminal blocks of the same profile and all other TOPJOB® S terminal blocks

- 1 Conductor sizes: 0.5 mm² - 10 mm² "s + f-st";
Push-in conductor sizes: 1 mm² - 10 mm² "s" and 1.5 mm² - 6 mm² "insulated ferrule, 12 mm"

- 2 AC/DC 1000 V = rated voltage
DC 1500 V
12 kV = rated surge voltage
3 = pollution degree
(see Full Line Catalog, Volume 1, Section 14)

- 3 Strip length, see packaging or instructions.
- 4 Protective warning marker must be applied individually.

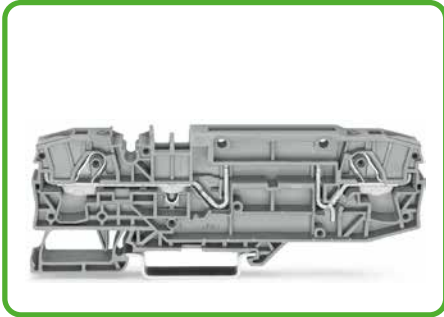

Carrier terminal block (2006-8661) with receptacle for orange disconnect plug

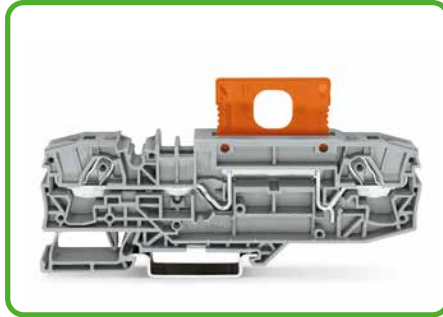

Orange disconnect plug (2006-8401) in operating position

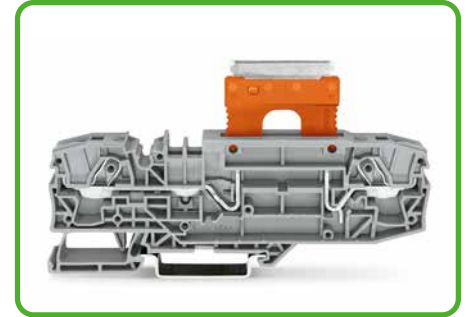

Orange disconnect plug (2006-8401) in parked position

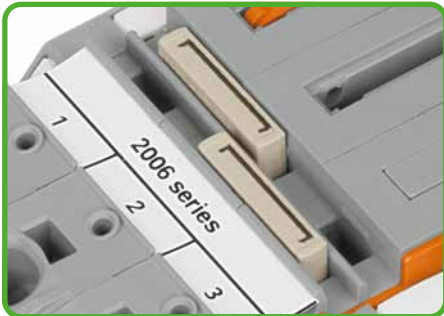

Commoning a 15 mm wide terminal block via push-in type jumper bars: 1 to 3 (2006-433) and 1 to 5 (2006-435).

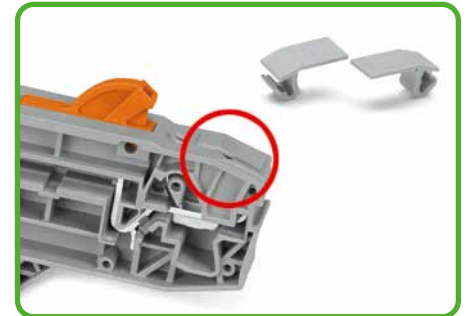

Cover seals unused conductor entry.

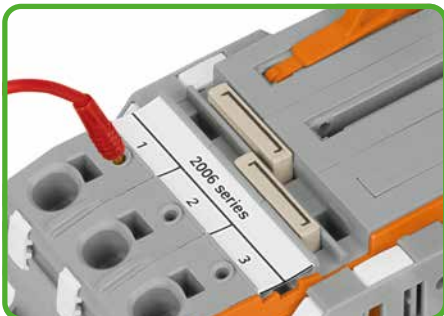

Test slots on both terminal block sides allow for direct measurement.



Alternatively, measurement can also be performed using TOPJOB® S connectors (2006-511) from terminal block 1 to 2. Spacer modules (2006-549) must be used to compensate for the 15 mm terminal block width.

Fuse Terminal Blocks for Class CC and 10 x 38 mm (1 3/32" x 1 1/2") Fuses 811 Series

2.5 - 16 mm ² 1000 VDC, 32 A	AWG 16 - 6 1000 VDC, 30 A [Ⓜ]	2.5 - 16 mm ² 690 VAC, 32 A 1000 VDC, 32 A	AWG 16 - 6 600 VAC, 30 A [Ⓜ] 750 VAC, 30 A [Ⓜ] 1000 VDC, 30 A [Ⓜ]	2.5 - 16 mm ² -	AWG 16 - 6 600 V, 30 A [Ⓜ] 600 V, 30 A [Ⓜ]
Terminal block width 17.5 mm / 0.689 in 12 - 13 mm / 0.49 in		Terminal block width 17.5 mm / 0.689 in 12 - 13 mm / 0.49 in		Terminal block width 17.5 mm / 0.689 in 12 - 13 mm / 0.49 in	



Item No.	Pack. Unit	Item No.	Pack. Unit	Item No.	Pack. Unit
Fuse terminal block for cylindrical fuses 10 x 38 mm; 1 3/32" x 1 1/2", for photovoltaic applications, light gray, without blown fuse indication, suitable for DIN 35 rail acc. to EN 60715		Fuse terminal block for 10 x 38 mm; 1 3/32" x 1 1/2", light gray, without blown fuse indication, suitable for DIN 35 rail acc. to EN 60715		Fuse terminal block for class CC fuses, light gray, without blown fuse indication, suitable for DIN 35 rail acc. to EN 60715	
○ 1-pole 811-316	12	○ 1-pole 811-310	12	○ 1-pole 811-410	12
		○ 2-pole 811-320	6	○ 2-pole 811-420	6
		○ 3-pole 811-330	4	○ 3-pole 811-430	4
Fuse terminal block for cylindrical fuses 10 x 38 mm; 1 3/32" x 1 1/2", for photovoltaic applications, light gray, with blown fuse indication, 230 - 1000 VDC, suitable for DIN 35 rail acc. to EN 60715		Fuse terminal block for 10 x 38 mm; 1 3/32" x 1 1/2", light gray, with blown fuse indication, 90 - 600 VAC, 115 - 600 VDC, suitable for DIN 35 rail acc. to EN 60715		Fuse terminal block for class CC fuses, light gray, with blown fuse indication, 90 - 600 VAC, 115 - 600 VDC, suitable for DIN 35 rail acc. to EN 60715	
○ 1-pole 811-317	12	○ 1-pole 811-311	12	○ 1-pole 811-411	12
		○ 2-pole 811-321	6	○ 2-pole 811-421	6
		○ 3-pole 811-331	4	○ 3-pole 811-431	4
		Fuse terminal block for 10 x 38 mm; 1 3/32" x 1 1/2", light gray, with blown fuse indication, 24 VDC, suitable for DIN 35 rail acc. to EN 60715		Fuse terminal block for class CC fuses, light gray, with blown fuse indication, 24 VDC, suitable for DIN 35 rail acc. to EN 60715	
		○ 1-pole 811-314		○ 1-pole 811-414	
Cylindrical fuses are not offered by WAGO. Temperature scale handling from -35 °C to +85 °C. Nominal voltage and current are given by the LED or fuse.		Cylindrical fuses are not offered by WAGO. Temperature scale handling from -35 °C to +85 °C. Nominal voltage and current are given by the LED or fuse.		Cylindrical fuses are not offered by WAGO. Temperature scale handling from -35 °C to +85 °C. Nominal voltage and current are given by the LED or fuse.	

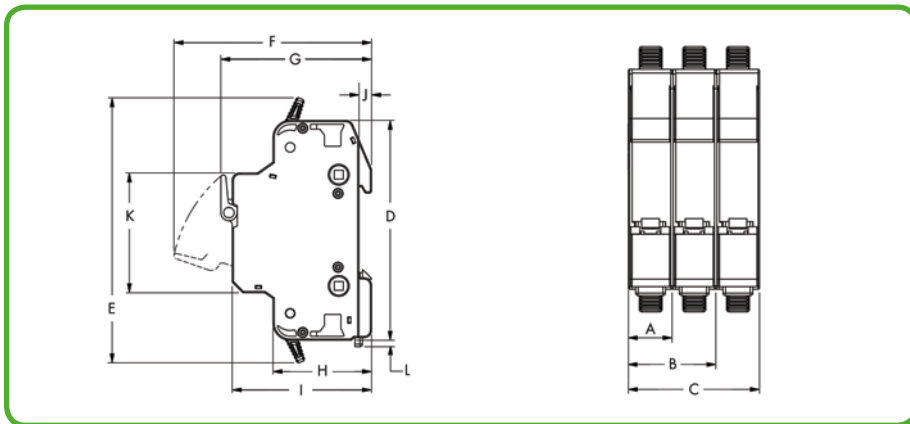

Dimension	mm (in.)
A	17.3 (0.68)
B	34.6 (1.36)
C	51.9 (2.04)
D	87 (3.43)
E	104.9 (4.13)
F	78.3 (3.08)
G	59.7 (2.35)
H	39 (1.54)
I	55.2 (2.17)
J	5 (0.2)
K	47.4 (1.87)
L	2.5 (0.1)



Conductor termination:
Open clamping unit via integrated lever.



Ferruled conductors up to 10 mm² (AWG 8) can be terminated.



Screwdriver used to open and close lever.



Inserting a fuse.



Remove terminal block from the carrier rail.



WMB marking location for convenient identification.



Marking adapter (285-442) allows the continuous marking strip to be used.



Jumper bar for quick and convenient commoning.



Coupling kit used to create a 2- or 3-pole fuse terminal block.

811 Series Accessories

Jumper bar, I_N 63 A, 1000 V (2 to 12 way versions)

	2-way	811-472	50 (5x10)
	3-way	811-473	40 (4x10)
	4-way	811-474	40 (4x10)
	5-way	811-475	40 (4x10)
	6-way	811-476	30 (3x10)
	7-way	811-477	20 (2x10)
	8-way	811-478	20 (2x10)
	9-way	811-479	20 (2x10)
	10-way	811-480	20 (2x10)
	11-way	811-481	20 (2x10)
	12-way	811-482	20 (2x10)

Supply module, 35 mm², 600 VAC, 1000 VDC

		811-471	16 (4x4)
---	--	----------------	----------

Test plug, with 500 mm cable, 2 mm Ø

	red	210-136	50
---	-----	----------------	----

Coupling kit for 12 poles

		811-612	1
---	--	----------------	---

Marker carrier, uses 2009-110 marker strip, 10.4 mm wide

	gray	285-442	25
---	------	----------------	----

Marking strip, plain, 11 mm wide, 50 m roll

	white	2009-110	1
---	-------	-----------------	---

WMB Multi marking system, 10 strips with 10 markers per card, stretchable 5 - 5.2 mm

	plain	793-5501	5
---	-------	-----------------	---

Screwless end stop, for DIN 35 rail, gray

	6 mm/0.236"	249-116	100 (4x25)
	10 mm/0.394"	249-117	50 (2x25)

Twin ferrules for 811 Series, insulated, L1 = 12 mm, sleeve for 2 x 2.5 mm² / AWG 14

	blue	216-545	100
	sleeve for 2 x 4 mm ² / AWG 12	216-546	100
	gray	216-546	100
	sleeve for 2 x 6 mm ² / AWG 10	216-547	100
	yellow	216-547	100

X-COM®-SYSTEM



Male Headers with Solder Pins and Rivet Fixing Flanges

Pin Spacing 5 mm

Pin spacing 5 mm / 0.197 in, gray
 250 V/4 kV/3 ①
 500 V/4 kV/2 ①
 I_N 32 A ②



- ① 250 V/500 V = rated voltage
 4 kV = rated surge voltage
 3/2 = pollution degree
 (see Full Line Catalog, Volume 1, Section 14)
- ② See current-carrying capacity curve at www.wago.com

Pole No.	Item No.	Pack. Unit
Male header with straight solder pins and rivet fixing flanges, 1 x 1 mm,		
gray		
2	769-632/007-000	200
3	769-633/007-000	50
4	769-634/007-000	50
5	769-635/007-000	50
6	769-636/007-000	50
7	769-637/007-000	25
8	769-638/007-000	25
9	769-639/007-000	25
10	769-640/007-000	25
11	769-641/007-000	25
12	769-642/007-000	25
13	769-643/007-000	15
14	769-644/007-000	15
15	769-645/007-000	15
Accessories		
1-conductor female plug,		1-conductor female plug,
	straight	
	gray	with lateral locking levers
	769-102	gray
	100	769-102/021-000
		50
Coding pin,		
	for coding female plugs	
	orange	769-435
		100 (4x25)

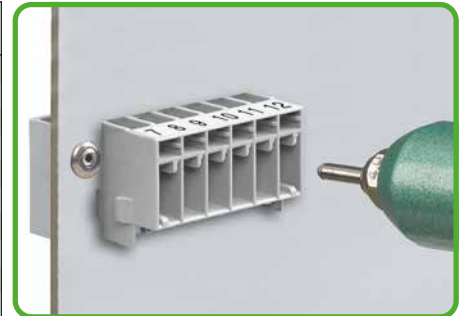

Mounting with 3 mm Ø blind rivets

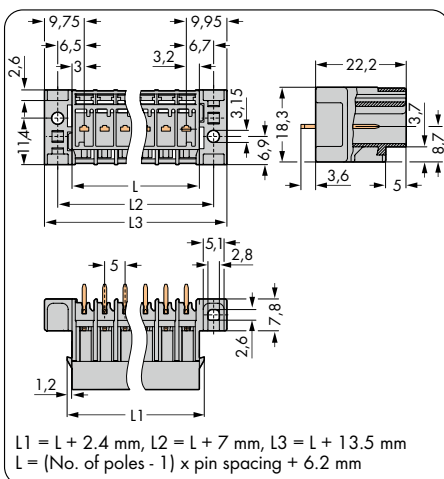

Dimensions in mm

Orange Version

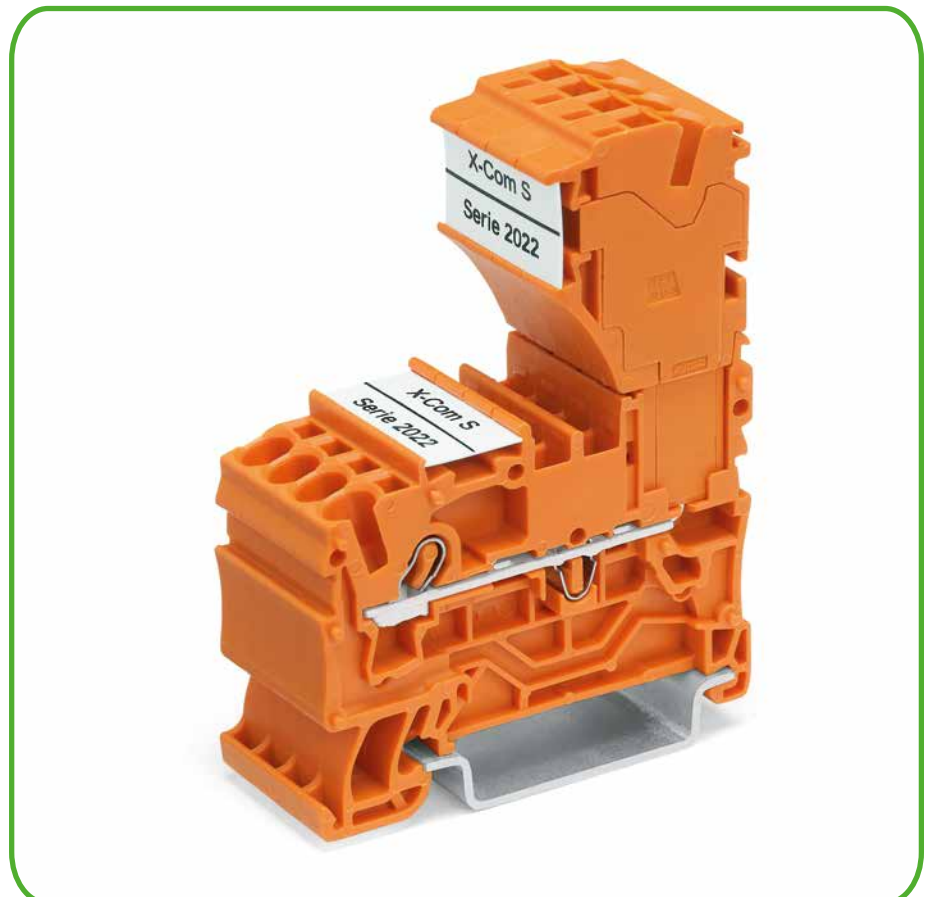

Technical Data see Full Line Catalog, Volume 1

1-Conductor/1-Pin Carrier Terminal Blocks 2022-1202	Page 394
2-Conductor/1-Pin-Carrier Terminal Blocks 2022-1302	Page 396
2-Conductor/2-Pin-Carrier Terminal Blocks 2022-1402	Page 396
and	
Female Plugs for Self-Assembly	Page 402
1-conductor end module 2022-182	
1-conductor center module 2022-172	
1-conductor base module 2022-162	
and	
1-Conductor Female Plugs	Page 400
2022-101/000-012	
2022-102/000-012	
2022-103/000-012	
2022-104/000-012	
2022-105/000-012	
2022-106/000-012	
2022-107/000-012	
2022-108/000-012	
2022-109/000-012	
2022-110/000-012	
2022-111/000-012	
2022-112/000-012	
2022-113/000-012	
2022-114/000-012	
2022-115/000-012	



2-Conductor/1-Pin; 2-Conductor/1-Pin and 2-Conductor/2-Pin
Carrier Terminal Blocks for Ex nA Applications, 2022 Series

Volume 1

0.25 - 2.5 (4) mm ² ① AWG 22 - 12 630 V ② I _N 20 A Terminal block width 5.2 mm / 0.205 in  10 - 12 mm / 0.43 in ③	0.25 - 2.5 (4) mm ² ① AWG 22 - 12 Terminal block width 5.2 mm / 0.205 in  10 - 12 mm / 0.43 in ③	0.25 - 2.5 (4) mm ² ① AWG 22 - 12 630 V ② I _N 20 A Terminal block width 5.2 mm / 0.205 in  10 - 12 mm / 0.43 in ③
---	--	--

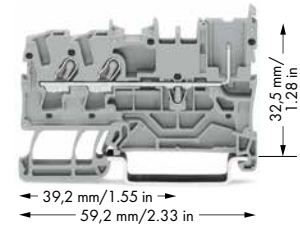
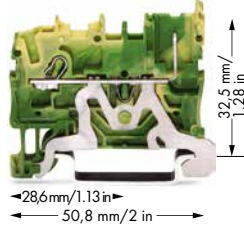
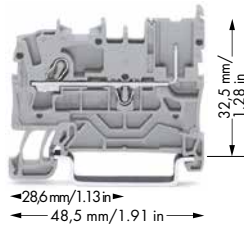

Item No.	Pack. Unit	Item No.	Pack. Unit	Item No.	Pack. Unit
1-conductor/1-pin carrier terminal block, for DIN 35 rail, acc. to EN 60715		1-conductor/1-pin ground carrier terminal block, for DIN 35 rail, acc. to EN 60715		2-conductor/1-pin carrier terminal block, for DIN 35 rail, acc. to EN 60715	
gray 2022-1201/999-953	100	green-yellow 2022-1207/999-953	100	gray 2022-1301/999-953	100
blue 2022-1204/999-953	100			blue 2022-1304/999-953	100
				2-conductor/1-pin ground carrier terminal block, for DIN 35 rail, acc. to EN 60715	
				green-yellow 2022-1307/999-953	100
Item-Specific Accessories		Item-Specific Accessories		Item-Specific Accessories	
End and intermediate plate, 1 mm thick		End and intermediate plate, 1 mm thick		End and intermediate plate, 1 mm thick	
orange 2022-1292	100 (4x25)	orange 2022-1292	100 (4x25)	orange 2022-1392	100 (4x25)
gray 2022-1291	100 (4x25)	gray 2022-1291	100 (4x25)	gray 2022-1391	100 (4x25)

2022 Series Accessories

Appropriate marking systems: WMB/Marking strips/WMB Inline
(see Full Line Catalog, Volume 1, Section 13)

Insulation stop, 5 pcs/strip, 0.25 - 0.5 mm ² light gray 2002-171 200 (8x25)	Staggered jumper, ④ insulated, I _N 25 A, light gray 2-way 2002-472 100 (4x25) 3-way 2002-473 100 (4x25) 4-way 2002-474 100 (4x25) 5-way 2002-475 50 (2x25) 6-way 2002-476 50 (2x25) 7-way 2002-477 50 (2x25) 8-way 2002-478 50 (2x25) 9-way 2002-479 50 (2x25) 10-way 2002-480 50 (2x25) 11-way 2002-481 50 (2x25) 12-way 2002-482 50 (2x25)	Protective warning marker, with high-voltage symbol, black, for 5 terminal blocks yellow 2002-115 100 (4x25)
Insulation stop, 5 pcs/strip, 0.75 - 1 mm ² dark gray 2002-172 200 (8x25)	Push-in type jumper bar, insulated, ④ I _N 25 A, light gray 2-way 2002-402 200 (8x25) 3-way 2002-403 200 (8x25) 4-way 2002-404 200 (8x25) 5-way 2002-405 100 (4x25) 6-way 2002-406 100 (4x25) 7-way 2002-407 100 (4x25) 8-way 2002-408 100 (4x25) 9-way 2002-409 100 (4x25) 10-way 2002-410 100 (4x25)	WMB Multi marking system, 10 strips with 10 markers per card, stretchable 5 - 5.2 mm plain 793-5501 5
Push-in type jumper bar, insulated, I _N 25 A, light gray from 1 to 3 2002-433 200 (8x25) from 1 to 4 2002-434 200 (8x25) from 1 to 5 2002-435 100 (4x25) from 1 to 6 2002-436 100 (4x25) from 1 to 7 2002-437 100 (4x25) from 1 to 8 2002-438 100 (4x25) from 1 to 9 2002-439 100 (4x25) from 1 to 10 2002-440 100 (4x25)	Push-in type wire jumper, ④ insulated, I _N 18 A, wire size 1.5 mm ² L = 60 mm 2009-412 100 (10x10) L = 110 mm 2009-414 100 (10x10) L = 250 mm 2009-416 100 (10x10)	WMB Multi marking system, plain, 10 strips with 10 markers per card, stretchable 5 - 5.2 mm yellow 793-5501/000-002 red 793-5501/000-005 blue 793-5501/000-006 gray 793-5501/000-007 orange 793-5501/000-012 light green 793-5501/000-017 green 793-5501/000-023 violet 793-5501/000-024 5
	Carrier with 6 coding pins, for coding female plugs orange 2022-100 100 (4x25)	WMB Inline, plain, stretchable 5 - 5.2 mm, 1,500 WMB markers, 5 mm, on roll white 2009-115 1
	Test pin, 1 mm Ø 859-500 1	Marking strip, plain, 11 mm wide, 50 m roll white 2009-110 1
		Screwless end stop, for DIN 35 rail, 6 mm wide gray 249-116 100 (4x25)

0.25 - 2.5 (4) mm² ① AWG 22 - 12
 630 V ②
 I_N 20 A
 Terminal block width 5.2 mm / 0.205 in
 10 - 12 mm / 0.43 in ③

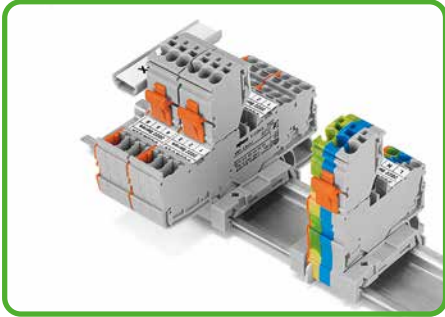

Each female plug is supplied with a locking lever.

- ① Conductor sizes: 0.25 mm² - 4 mm² "s + f-st"; Push-in conductor sizes: 0.75 mm² - 4 mm² "s" and 0.75 mm² - 2.5 mm² "insulated ferrule, 12 mm"
- ② 630 V = rated voltage for Ex nA applications (see Full Line Catalog, Volume 1, Section 14)
- ③ Strip length, see packaging or instructions.
- ④ See application notes in Full Line Catalog, Volume 1, for: Colored push-in type jumper bars, page 139; Staggered jumper, page 141; Push-in type wire jumper, page 140; Marker carrier, page 145

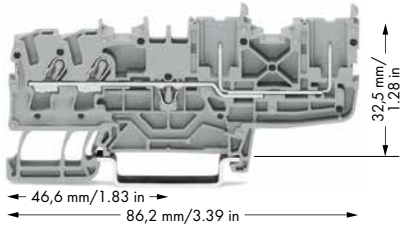

Item No.	Pack. Unit
2-conductor/2-pin carrier terminal block, for DIN 35 rail, acc. to EN 60715	
gray 2022-1401/999-953	50
blue 2022-1404/999-953	50
2-conductor/2-pin ground carrier terminal block, for DIN 35 rail, acc. to EN 60715	
green-yellow 2022-1407/999-953	50
Item-Specific Accessories	
End and intermediate plate, 1 mm thick	
orange 2022-1492	100 (4x25)
gray 2022-1491	100 (4x25)

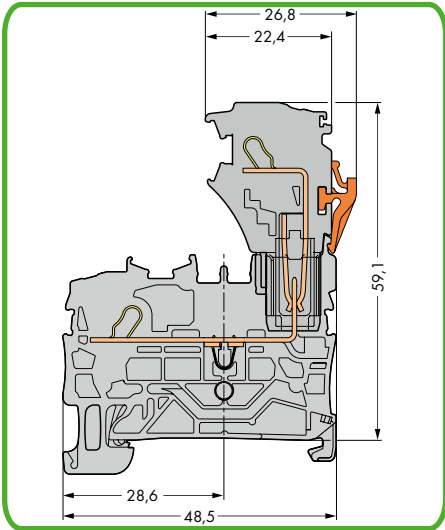



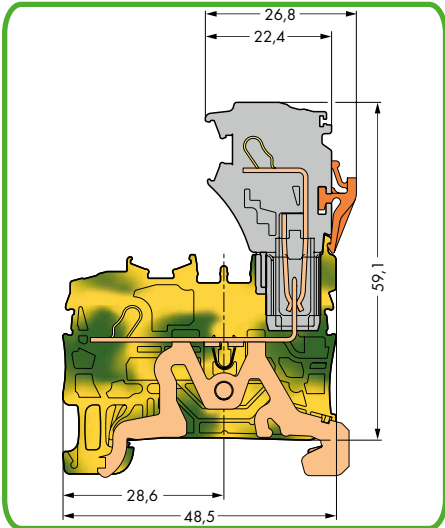











Carrier terminal block



Ground carrier terminal block

- ❶ Conductor sizes: 0.25 mm² – 4 mm² "s + f-st";
Push-in conductor sizes: 0.75 mm² – 4 mm² "s"
and 0.75 mm² – 2.5 mm²
"insulated ferrule, 12 mm"
- ❷ 630 V = rated voltage for Ex nA applications
(see Full Line Catalog, Volume 1, Section 14)
- ❸ with double-deck vertical jumper 19 A
- ❹ Strip length, see packaging or instructions.
- ❺ See application notes in Full Line Catalog, Volume 1, for:
Colored push-in type jumper bars, page 139
Vertical jumper, page 142

2022 Series Accessories	
Appropriate marking systems: WMB/Marking strips/WMB Inline (see Full Line Catalog, Volume 1, Section 13)	
End and intermediate plate, 1 mm thick  orange 2022-2292 100 (4x25)  gray 2022-2291 100 (4x25)	Protective warning marker, with high-voltage symbol, black,  for 5 terminal blocks yellow 2002-115 100 (4x25)
Insulation stop,  5 pcs/strip, 0.25 - 0.5 mm ² light gray 2002-171 200 (8x25)	Double-deck marker carrier,  pivoting gray 2002-121 50 (2x25)
Insulation stop,  5 pcs/strip, 0.75 - 1 mm ² dark gray 2002-172 200 (8x25)	WMB Multi marking system,  10 strips with 10 markers per card, stretchable 5 - 5.2 mm plain 793-5501 5
Push-in type jumper bar, insulated, I _N 25 A,  light gray 2-way 2002-402 200 (8x25) 3-way 2002-403 200 (8x25) 4-way 2002-404 200 (8x25) 5-way 2002-405 100 (4x25) 6-way 2002-406 100 (4x25) 7-way 2002-407 100 (4x25) 8-way 2002-408 100 (4x25) 9-way 2002-409 100 (4x25) 10-way 2002-410 100 (4x25)	WMB Multi marking system, plain,  10 strips with 10 markers per card, stretchable 5 - 5.2 mm yellow 793-5501/000-002 red 793-5501/000-005 blue 793-5501/000-006 gray 793-5501/000-007 orange 793-5501/000-012 light green 793-5501/000-017 green 793-5501/000-023 violet 793-5501/000-024 5
Push-in type jumper bar, insulated, I _N 25 A,  light gray from 1 to 3 2002-433 200 (8x25) from 1 to 4 2002-434 200 (8x25) from 1 to 5 2002-435 100 (4x25) from 1 to 6 2002-436 100 (4x25) from 1 to 7 2002-437 100 (4x25) from 1 to 8 2002-438 100 (4x25) from 1 to 9 2002-439 100 (4x25) from 1 to 10 2002-440 100 (4x25)	WMB Inline, plain,  stretchable 5 - 5.2 mm, 1,500 WMB markers, 5 mm, on roll white 2009-115 1
	Marking strip, plain,  11 mm wide, 50 m roll white 2009-110 1
Double-deck vertical jumper, insulated, I _N 24 A  light gray 2002-492 100 (4x25) orange 2002-492/000-012	
Carrier with 6 coding pins,  for coding female plugs orange 2022-100 100 (4x25)	
Test pin,  1 mm Ø 859-500 1	

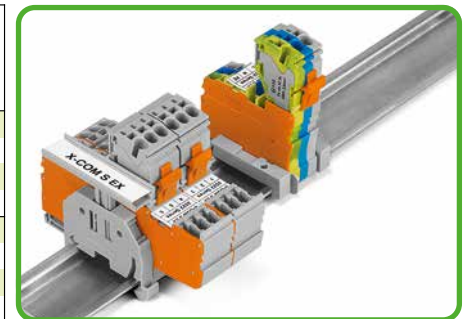

Group marking with height-adjustable group marker carrier (2009-163)

X-COM® S-SYSTEM

1-Conductor Female Plugs for Ex nA Applications

2022 Series

0.25 - 2.5 (4) mm² ① AWG 22 - 12
 630 V ②
 I_N 20 A
 Module width 5.2 mm / 0.205 in
 10 - 12 mm / 0.43 in ③



- ① Conductor sizes: 0.25 mm² - 4 mm² "s + f-st"; Push-in conductor sizes: 0.75 mm² - 4 mm² "s" and 0.75 mm² - 2.5 mm² "insulated ferrule, 12 mm"
- ② 630 V = rated voltage for Ex nA applications
- ③ (see Full Line Catalog, Volume 1, Section 14)
- ④ Strip length, see packaging or instructions.

Pole No.	Item No.	Pack. Unit	Accessories
1-conductor female plug with shorter locking lever, for insertion into carrier terminal blocks, with coding fingers, gray According to EN 61984, connectors without current interrupting capacity shall not be mated and unmated when live or under load.			Appropriate marking system: (see Full Line Catalog, Volume 1, Section 13)
② 2 2022-102/999-953 200 ③ 3 2022-103/999-953 100 ④ 4 2022-104/999-953 100 ⑤ 5 2022-105/999-953 50 ⑥ 6 2022-106/999-953 50 ⑦ 7 2022-107/999-953 50 ⑧ 8 2022-108/999-953 50			Insulation stop, 5 pcs/strip, 0.25 - 0.5 mm ² light gray 2002-171 200 (8x25)
			Insulation stop, 5 pcs/strip, 0.75 - 1 mm ² dark gray 2002-172 200 (8x25)
			Protective warning marker, with high-voltage symbol, black, for 5 terminal blocks yellow 2002-115 100 (4x25)
			Carrier with 6 coding pins, for coding female plugs orange 2022-100 100 (4x25)
			Strain relief plate, gray 35 mm width 734-326 100 (4x25) 6 mm wide 734-327 100 (4x25) 12.5 mm width 734-328 100 (4x25) 25 mm wide 734-329 100 (4x25) 55 mm width 734-430 50 (2x25) 75 mm width 734-431 50 (2x25)
			WMB Multi marking system, 10 strips with 10 markers per card, stretchable 5 - 5.2 mm plain 793-5501 5
			WMB Inline, plain, stretchable 5 - 5.2 mm, 1,500 WMB markers, 5 mm, on roll white 2009-115 1
			Marking strip, plain, 11 mm wide, 50 m roll white 2009-110 1



To code a female plug, remove the desired coding finger using a suitable tool.

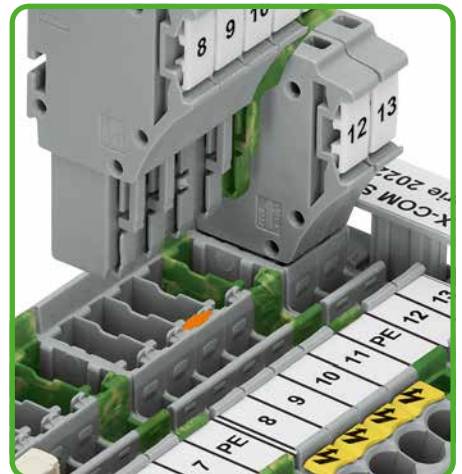

Insert a 2022-100 coding pin into the corresponding location of the carrier terminal block.

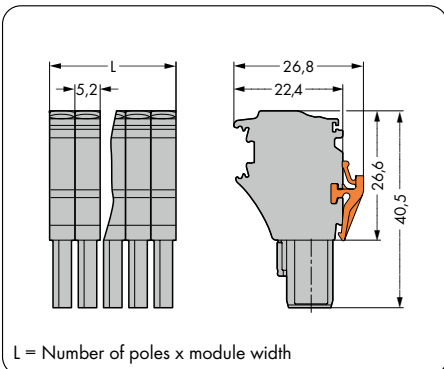

Dimensions in mm

X-COM® -SYSTEM

Pre-Assembled Female Plugs for Ex nA Applications

2022 Series

0.25 - 2.5 (4) mm² ❶ | AWG 22 - 12

630 V ❷

I_N 20 A

Module width 5.2 mm / 0.205 in

 10 - 12 mm / 0.43 in ❸

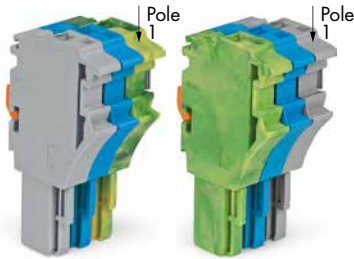
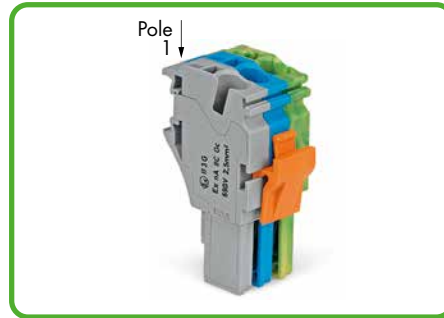







- ❶ Conductor sizes: 0.25 mm² - 4 mm² "s + f-st"; Push-in conductor sizes: 0.75 mm² - 4 mm² "s" and 0.75 mm² - 2.5 mm² "insulated ferrule, 12 mm"
- ❷ 630 V = rated voltage for Ex nA applications
- ❸ (see Full Line Catalog, Volume 1, Section 14)
- ❹ Strip length, see packaging or instructions.

Pole No.	Item No.	Pack. Unit		
1-conductor female plug with shorter locking lever with ground base module (green-yellow), for insertion into carrier terminal blocks, with coding fingers, gray, blue, green-yellow				
3	2022-103/000-038/999-953	100		
1-conductor female plug with shorter locking lever with ground end module (green-yellow), for insertion into carrier terminal blocks, with coding fingers, green-yellow, blue, gray				
3	2022-103/000-039/999-953	100		
For other lengths up to maximum 15 poles, please contact factory.				

Accessories Female Plugs

Appropriate marking systems: WMB/Marking strips/WMB Inline
(see Full Line Catalog, Volume 1, Section 13)

Insulation stop,  5 pcs/strip, 0.25 - 0.5 mm ² light gray 2002-171 200 (8x25)	WMB Multi marking system,  10 strips with 10 markers per card, stretchable 5 - 5.2 mm plain 793-5501 5
Insulation stop,  5 pcs/strip, 0.75 - 1 mm ² dark gray 2002-172 200 (8x25)	WMB Inline, plain,  stretchable 5 - 5.2 mm, 1,500 WMB markers, 5 mm, on roll white 2009-115 1
Protective warning marker,  with high-voltage symbol, black, for 5 terminal blocks yellow 2002-115 100 (4x25)	Marking strip, plain,  11 mm wide, 50 m roll white 2009-110 1
Strain relief plate, gray 	
35 mm width 734-326 100 (4x25) 6 mm wide 734-327 100 (4x25) 12.5 mm width 734-328 100 (4x25) 25 mm wide 734-329 100 (4x25) 55 mm width 734-430 50 (2x25) 75 mm width 734-431 50 (2x25)	

Conductor termination – Step 1



Rotate Allen wrench counterclockwise to the stop ①. Then, push in orange locking tab for hands-free wiring.

Commoning

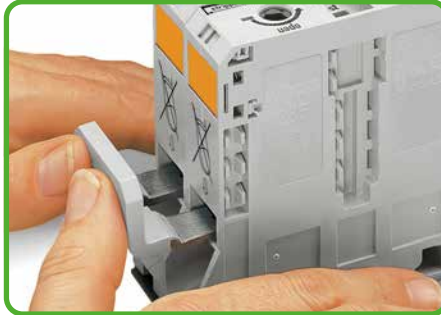

Commoning with adjacent jumper: Inserting the jumper above the conductor entry hole – prior to conductor termination. The nominal cross section remains unchanged.



Removing jumper via operating tool.

Conductor termination – Step 2



Insert stripped conductor until it hits backstop; hold this in position.



Conductor termination – Step 3



Unlock the locking tab with a short counter-clockwise turn ② of the Allen wrench to securely terminate the conductor.

Assembly



Snapping a terminal block onto the carrier rail. From the left or from the right.

Removal



Removing a terminal block from the assembly. To the left or to the right.



POWER CAGE CLAMP clamps the following copper conductors:
solid



stranded



fine-stranded, also with tinned single strands

- Description and Handling -

Safety notes



For an optimum clamping force:
 1. Bend conductor
 2. Cut conductor to length (Conductor end must be straight!)
 3. Strip conductor



Always observe the printed strip length!



Caution! Health hazard!
 Keep your fingers out of the conductor entry hole!

Safety notes



Protective warning marker may indicate:
 Caution! Power is still on even after switching off the main switch!

Grounding foot



Ground conductor terminal blocks (limited to max. 120 mm²/250 MCM acc. to EN 60947-7-2) must be snapped onto a 2.3 mm thick copper carrier rail.

Ground conductor terminal blocks

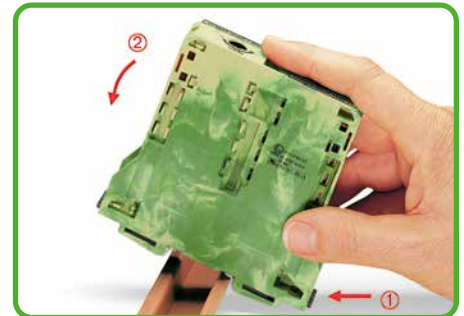

Firmly snap the ground conductor terminal block onto the carrier rail. The contact foot is automatically secured on the rail, providing the appropriate power grounding connection.

Touchproof protection



Yellow, detachable covers provide touchproof safety by shielding jumper contact slots and/or unused conductor entries.

Testing



Testing with touch-proof test sockets 4 mm Ø.
 (not offered by WAGO - e.g., mfd by Multi-Contact Deutschland GmbH)



Side-entry wiring means that even larger conductors, which offer limited flexibility, can be easily connected.

Marking



WMB markers or self-adhesive, printable marking strips can be accommodated on 35, 50 and 95 mm² high-current terminal blocks.

Marking

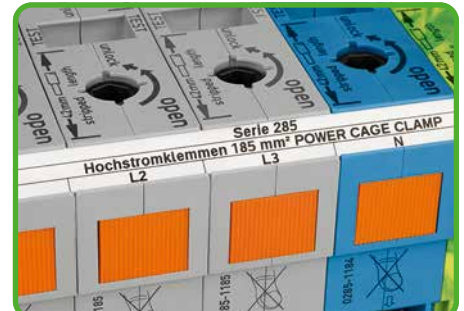

Besides WMB markers, marking strips can also be directly accommodated on the 185 mm² (350 MCM) terminal block.



fine-stranded,
 with ferrule
 (gastight crimped)

High-Current Through and Ground Conductor Terminal Blocks

185 mm² 285 Series

50 - 185 mm² | 2/0 AWG - 350 kcmil
1000 V AC/DC/1500 VDC/12 kV/3 ①
I_N 353 A

Terminal block width 32 mm / 1.26 in
45 - 47 mm / 1.77 - 1.85 in ②

50 - 120 mm² | 1/0 AWG - 250 kcmil

Terminal block width 32 mm / 1.26 in
45 - 47 mm / 1.77 - 1.85 in ②

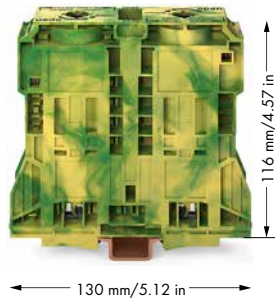
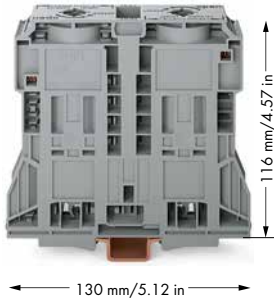

Item No.	Pack. Unit	Item No.	Pack. Unit
2-conductor through terminal block, to be used exclusively on DIN 35 x 15 rail gray 285-1185 5 blue 285-1184 5		2-conductor ground terminal block, to be used exclusively on DIN 35 x 15 rail; 2.3 mm thick, copper green-yellow 285-1187 5	
Item-Specific Accessories		Item-Specific Accessories	
Steel carrier rail, acc. to EN 60715, 35 x 15 mm, 2.3 mm, 2 m/6'6" long unslotted 210-118 10		Copper carrier rail, acc. to EN 60715, 35 x 15 mm, 2.3 mm, 2 m/6'6" long unslotted 210-198 10	
Copper carrier rail, acc. to EN 60715, 35 x 15 mm, 2.3 mm, 2 m/6'6" long unslotted 210-198 10			
285 Series Accessories			
Appropriate marking systems: WMB/Marking strips/WMB Inline (see Full Line Catalog, Volume 1, Section 13)			
Adjacent jumper, insulated, I _N 309 A for 1 jumper gray 285-1171 25		WMB Inline, plain, stretchable 5 - 5.2 mm, 1,500 WMB markers, 5 mm, on roll white 2009-115 1	
Protective warning marker, with high-voltage symbol, black yellow 285-1177 50 (2x25)		Marking strip, plain, 11 mm wide, 50 m roll white 2009-110 1	
Finger guard, touchproof cover protects unused conductor entries and jumper slots yellow 285-1178 25		WMB Multi marking system, 10 strips with 10 markers per card, for terminal widths 5 - 17.5 mm plain 793-501 5	
Allen wrench with partially insulated shaft 285-172 1		WMB Multi marking system, 10 strips with 10 markers per card, stretchable 5 - 5.2 mm plain 793-5501 5	
Three-phase set, with 35mm ² high-current terminal blocks 285-1169 1			
Screwless end stop, for DIN 35 rail, 14 mm wide gray 249-197 10			

- 1 AC/DC up to 1000 V = rated voltage
DC up to 1500 V
12 kV = rated surge voltage
3 = pollution degree
(see Full Line Catalog, Volume 1, Section 14)
- 2 Strip length, see packaging or instructions.

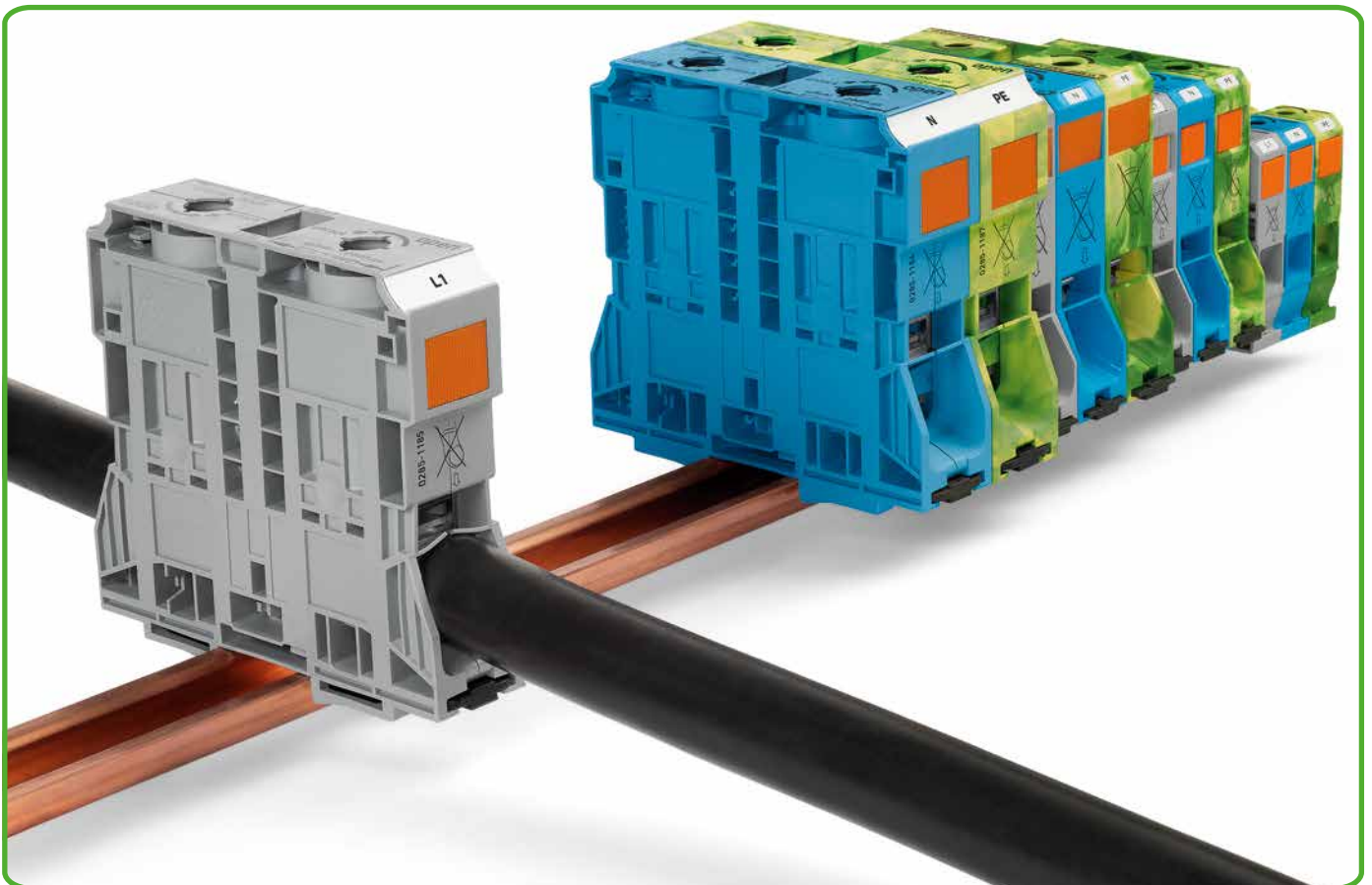

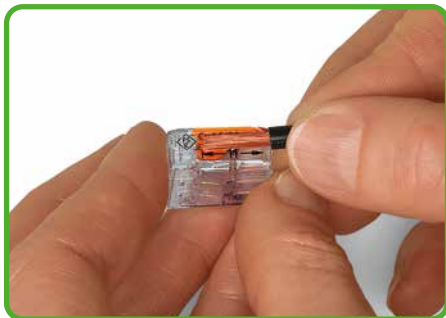

Strip wire to 11 mm / 0.43 in.



Termination: Open clamping unit using the lever and insert conductor.

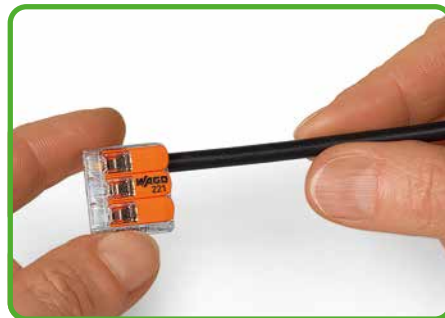

Then lower lever to close the clamp.

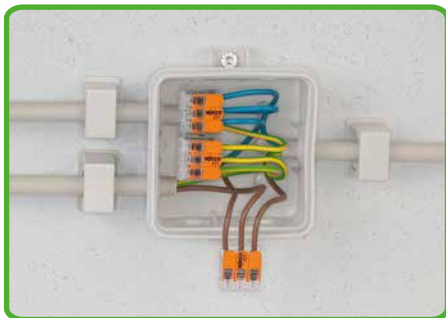

Wiring fine-stranded conductors in a junction box.



Individual design of low-voltage lighting systems.



Lighting distribution in ceiling canopy



Pendant light connection in suspended ceilings

CAGE CLAMP®
 clamps the following
 copper conductors:*

solid

stranded

fine-stranded,
 also with tinned
 single strands

fine-stranded,
 tip-bonded

* For aluminum conductors, see notes in Full Line Catalog, Volume 1, Section 14.

COMPACT Splicing Connectors for All Conductor Types 221 Series

0.2 - 4 mm ² "s+st" 0.14 - 4 mm ² "f-st" 450 V/4 kV/2 ① I _N 32 A 11 mm / 0.43 in ②	AWG 24 - 12	0.2 - 4 mm ² "s+st" 0.14 - 4 mm ² "f-st" 450 V/4 kV/2 ① I _N 32 A 11 mm / 0.43 in ②	AWG 24 - 12
---	-------------	---	-------------



- ① in grounded power lines
450 V = rated voltage
4 kV = rated surge voltage
2 = pollution degree
(see Full Line Catalog, Volume 1, Section 14)
- ② Strip length, see packaging or instructions.

Item No.	Pack. Unit	Item No.	Pack. Unit
COMPACT splicing connector for all conductor types, 2-conductor connector, with levers,		COMPACT splicing connector for all conductor types, 3-conductor connector, with levers,	
max. continuous service temperature 105°C		max. continuous service temperature 105°C	
221-412	1000 (10x100)	221-413	500 (10x50)



Compact splicing connectors
Tool-free connection of up to 5 stripped fine-stranded conductors from 0.14 to 4 mm²/AWG 24 - 12, solid or stranded conductors from 0.2 to 4 mm²/AWG 24 - 12.

This is how it works:

Open the clamping point using one of the orange operating levers until the lever is in vertical position. The conductor can now be inserted, then the lever can be returned to its rest position, flush with the connector housing.

The safety:

The specially designed rest position of the lever reliably prevents accidental unclamping of a connected conductor. Application safety, for any type of conductor (solid, stranded, fine-stranded), is confirmed by approvals like ENEC and UL.

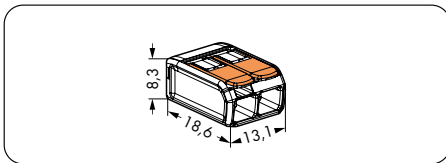

Dimensions in mm

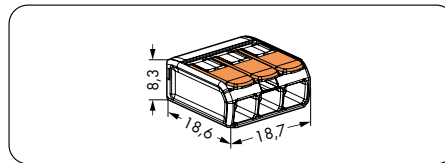

Dimensions in mm



Item No.	Pack. Unit
COMPACT splicing connector for all conductor types, 5-conductor connector, with levers,	
max. continuous service temperature 105°C	
221-415	400 (10x40)

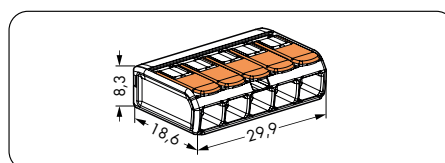

Dimensions in mm

	Vario-T-BOXX High-quality Sortimo® plastic case containing a selection of WAGO installation connectors Dimensions: 440 x 350 x 80 mm	Variobox Indestructible Sortimo® metal case containing a selection of WAGO installation connectors Dimensions: 440 x 330 x 66 mm
--	---	---



Description	Item No.	Pack. Unit	Item No.	Pack. Unit
Vario-T-BOXX, Variobox	Vario-T-BOXX		Variobox	
	887-910	1	887-911	1
High-quality Sortimo® cases contain a selection of WAGO connectors for all applications in electrical building installations.	Contains:		Contains:	
	COMPACT PUSH WIRE® connectors for junction boxes		COMPACT PUSH WIRE® connectors for junction boxes	
	2 x 0.5 - 2.5 mm ² 2273-202	100	2 x 0.5 - 2.5 mm ² 2273-202	100
	3 x 0.5 - 2.5 mm ² 2273-203	100	3 x 0.5 - 2.5 mm ² 2273-203	100
	5 x 0.5 - 2.5 mm ² 2273-205	100	5 x 0.5 - 2.5 mm ² 2273-205	100
	8 x 0.5 - 2.5 mm ² 2273-208	50	8 x 0.5 - 2.5 mm ² 2273-208	50
	Compact splicing connectors		Compact splicing connectors	
	3 x 0.08 - 4 mm ² 222-413	50	3 x 0.08 - 4 mm ² 222-413	50
	5 x 0.08 - 4 mm ² 222-415	40	5 x 0.08 - 4 mm ² 222-415	40
	Lighting connectors		Lighting connectors	
	1 - 2.5 mm ² 224-101	100	1 - 2.5 mm ² 224-101	100
	MICRO PUSH WIRE® connectors for junction boxes		MICRO PUSH WIRE® connectors for junction boxes	
	dark gray		dark gray	
	4 x 0.6 - 0.8 mm Ø 243-204	100	4 x 0.6 - 0.8 mm Ø 243-204	100
	red		red	
	4 x 0.6 - 0.8 mm Ø 243-804	100	4 x 0.6 - 0.8 mm Ø 243-804	100
	dark gray		dark gray	
	8 x 0.6 - 0.8 mm Ø 243-208	50	8 x 0.6 - 0.8 mm Ø 243-208	50
	Mounting carrier		Mounting carrier	
	for 6 connectors 243-113	10	for 6 connectors 243-113	10

New Products – Volume 1

Separators for Matrix Patching Terminal Blocks, Power Supply Connectors and Strain Relief Plates

Seperator	0.5 - 2.5 mm ² 500 V/4 kV/2 I _N 24 A 8 - 9 mm / 0.31 - 0.35 in	AWG 18 - 12	Strain relief plate
-----------	---	-------------	---------------------

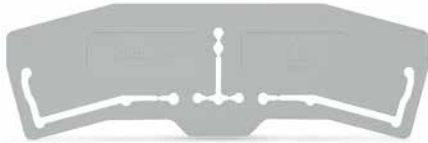

Item No.	Pack. Unit	Item No.	Pack. Unit	Item No.	Pack. Unit
Seperator, 3 mm oversized, 1 mm thick		Lighting connector without ground contact, Linect[®], with snap-in mounting feet,		Strain relief plate, with locking clip, for multicore cable: 1 x outer diameter 5.2 - 12 mm	
○ gray	280-394	100 (4x25)			
● orange	280-395	100 (4x25)			
		2-pole, white			
		○ DA- DA+	294-8032	1000	○ white 294-364 50
					Strain relief plate, with locking clip, for flat cables and individual conductors: min. 3 x 0.5 mm², max. 5 x 2.5 mm² or 7 x 1.5 mm²
					○ white 294-384 50

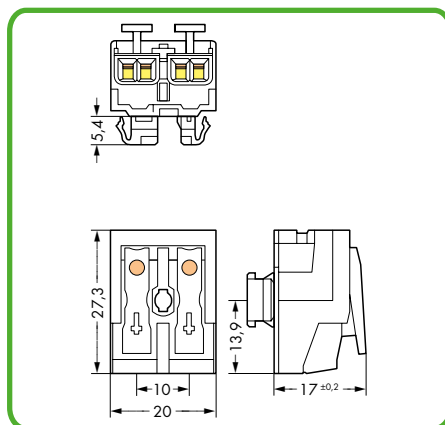

Dimensions in mm

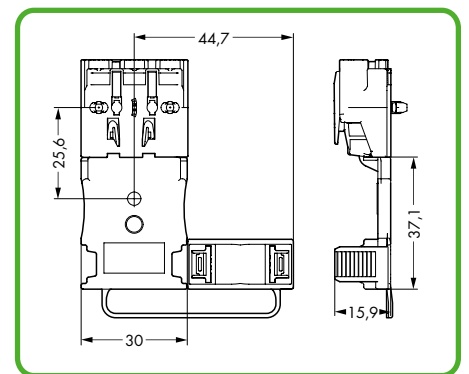

Dimensions in mm



Separator for 3-conductor, double-potential terminal blocks (280-675)

Contents

Volume 2

	Series	Pages
	SMD Terminal Blocks, 0.34 mm ² , 3 mm Pin Spacing, White	2059 58 – 59
	SMD Terminal Blocks with Push-Buttons, 0.75 mm ² , 4 mm Pin Spacing, White	2060 60 – 61
	SMD Terminal Blocks with Push-Buttons 0.75 mm ² , 8 mm Pin Spacing, White and Black	2060 62 – 63
	SMD Terminal Blocks with Push-Buttons 1.5 mm ² , 6 mm Pin Spacing, White and Black	2061 64 – 65
	SMD Terminal Blocks with Push-Buttons, 0.75 mm ² , 4 mm Pin Spacing, Black	2060 66 – 67
	SMD Terminal Blocks with Push-Buttons 0.75 mm ² , 8 mm Pin Spacing, Light Gray	2060 68 – 69
	THR Terminal Blocks with Push-Buttons 0.75 mm ² , 4 mm Pin Spacing, Light Gray and Black	2060 70 – 71
	THR Terminal Blocks with Push-Buttons 0.75 mm ² , 8 mm Pin Spacing, Light Gray and Black	2060 72 – 73
	Connecting Link for SMD Terminal Blocks with Push-Buttons, 4 mm Pin Spacing	2060 74 – 75
	Operating Tools	2059 76 2060 76 2061 76

Contents

Volume 2

	Series	Pages
	THR Terminal Blocks with Push-Buttons, 3.5 mm Pin Spacing, in Tape-and-Reel Packaging	2081 78 – 79
	THR Terminal Blocks with Push-Buttons, 3.5 mm Pin Spacing, in Tape-and-Reel Packaging	805 80 – 81
	Terminal Blocks with Push-Buttons, 3.5 mm Pin Spacing	805 82 – 83
	Terminal Blocks with Push-Buttons, 2.5 mm Pin Spacing	250 84 – 85
	Terminal Blocks with Angled Push-Buttons, Pin Spacing 5/5.08 mm, 7.5/7.62 mm, 10/10.16 mm	256 86 – 88
	Male Headers with Solder Pins 1 x 1 mm, THR, Pin spacing 5.08 mm <i>MCS MIDI Classic</i>	231 90 – 91
	Strain Relief Plates <i>MCS MAXI</i>	831 92
	Empty Housings	2857 86 – 89
	Stripboards for Empty Housings	2857 98 – 99

1 SMD Terminal Blocks, 0.34 mm² 3 mm Pin Spacing 2059 Series

58

Volume 2



- SMD terminal blocks with PUSH WIRE® connection technology
- Push-in termination of solid conductors
- Easy conductor removal, e.g., via operating tool
- Just 2.7 mm high
- Side-by-side arrangement without pole loss
- Available in tape-and-reel packaging for automated assembly

Technical Data

Pin Spacing	3 mm 0.118 in		
Ratings per	IEC/EN 60664-1		
Overvoltage category	III	III	II
Degree of contamination	3	2	2
Rated voltage	63 V	160 V	320 V
Rated surge voltage	2.5 kV	2.5 kV	2.5 kV
Nominal current	3 A	3 A	3 A
Approvals per	UL 1977		
Rated voltage, 1-pole	600 V		
Rated voltage, 2 or more poles	250 V		
Nominal current UL	3 A		

Conductor data:

Connection technology	PUSH WIRE®
Conductor size: solid	0.14–0.34 mm ²
AWG	26–22 "sol."
Strip length	4–5.5 mm / 0.16–0.22 in
Conductor entry	0° to PCB

Material data:

Material group	I
Insulation material	Glass-fiber-reinforced polyphthalamide (PPA-GF)
Flammability rating per UL 94	V0
Lower/Upper limit temperature	-60 °C / +105 °C
Contact material	Copper alloy
Contact plating	Tin-plated

2059 Series accessories:

Page:

Operating tool (206-859)	76
Operating tool (2059-189)	76

Application note:

Suitable for lead-free, reflow-soldering profiles acc. to DIN EN 61760-1 and IEC 60068-2-58 up to max. 260 °C peak temperature. Due to customer-specific variables (e.g., component configuration and orientation, type of soldering machine, solder paste), trial runs are recommended to ensure product and process compatibility under actual manufacturing conditions.

Recommendation for SMD positioning pattern: Material thickness, 150 µm. Pattern layout identical to solder pad layout.

Pin spacing 3 mm / 0.118 in	
0.14–0.34 mm ² "sol."	26–22 AWG "sol."
160 V/2.5 kV/2	3 A

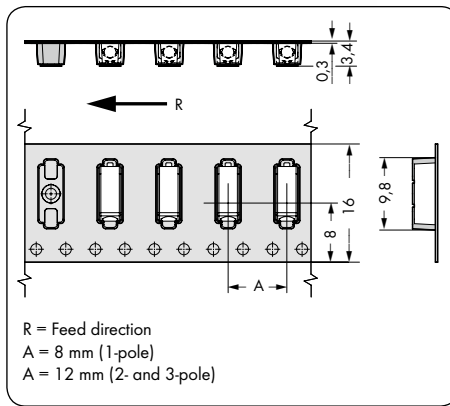
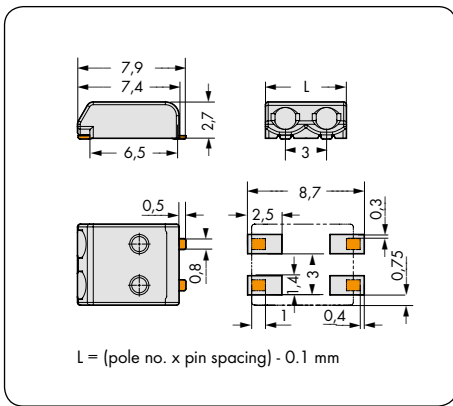

Pole No.	Item No.	Pack. Unit
SMD terminal blocks in tape-and-reel packaging, white *		
1	2059-301/998-403	31800 (12 x 2650)
2	2059-302/998-403	21000 (12 x 1750)
3	2059-303/998-403	21000 (12 x 1750)
Reel diameter: 330 mm		



Inserting solid conductors via push-in termination.



Easy conductor removal, e.g., via 206-859 operating tool.

* Depending on reflow soldering temperatures and times, color deviations may occur. These deviations will have no impact on functionality.

SMD Terminal Blocks with Push-Buttons, 0.75 mm² 4 mm Pin Spacing 2060 Series



- SMD terminal blocks with CAGE CLAMP® S and push-buttons
- Push-in termination of solid and ferruled conductors
- Convenient termination/removal of fine-stranded conductors via push-buttons
- Just 4.5 mm high
- Available in tape-and-reel packaging for automated assembly
- White version

Technical Data

Pin Spacing	4 mm 0.157 in		
Ratings per	IEC/EN 60664-1		
Overtoltage category	III	III	II
Degree of contamination	3	2	2
Rated voltage	63 V	160 V	320 V
Rated surge voltage	2.5 kV	2.5 kV	2.5 kV
Nominal current	9 A	9 A	9 A
Approvals per	UL 1977		
Rated voltage, 1-pole	600 V		
Rated voltage, 2 or more poles	250 V		
Nominal current UL	9 A		

Conductor data:

Connection technology	CAGE CLAMP® S
Conductor size: solid	0.2–0.75 mm ²
Conductor size: fine-stranded	0.2–0.75 mm ²
Conductor size: fine-stranded	0.25–0.34 mm ² (with insulated ferrule)
Conductor size: fine-stranded	0.25–0.34 mm ² (with uninsulated ferrule)
AWG	24 – 18
Strip length	7–9 mm / 0.28–0.35 in
Conductor entry	0° to PCB

Material data:

Material group	I
Insulation material	Glass-fiber-reinforced polyphthalamide (PPA-GF)
Flammability rating per UL 94	V0
Lower/Upper limit temperature	-60 °C / +105 °C
Contact material	Copper alloy
Contact plating	Tin-plated

Application note:

Suitable for lead-free, reflow-soldering profiles acc. to DIN EN 61760-1 and IEC 60068-2-58 up to max. 260 °C peak temperature. Due to customer-specific variables (e.g., component configuration and orientation, type of soldering machine, solder paste), trial runs are recommended to ensure product and process compatibility under actual manufacturing conditions.

Recommendation for SMD positioning pattern: Material thickness, 150 µm. Pattern layout identical to solder pad layout.

Current-Carrying Capacity Curve

Pin spacing: 4 mm / Conductor size: 0.75 mm² "f-st"
Based on: EN 60512-5-2 / Reduction factor: 1

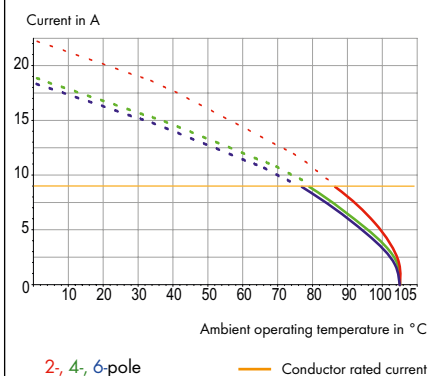

2060 Series accessories:

Page:

Operating tool (206-860)	76
Operating tool (2060-189)	76

Pin spacing 4 mm / 0.157 in	
0.2-0.75 mm ² 160 V/2.5 kV/2 9 A	24-18 AWG

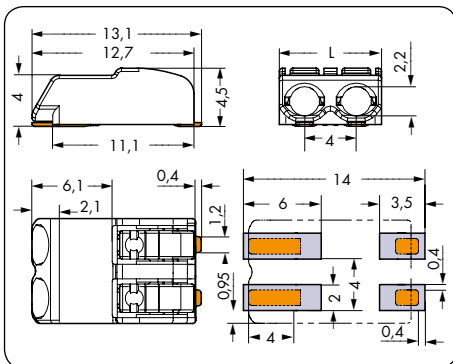

L = (pole no. x pin spacing) + 0.1 mm

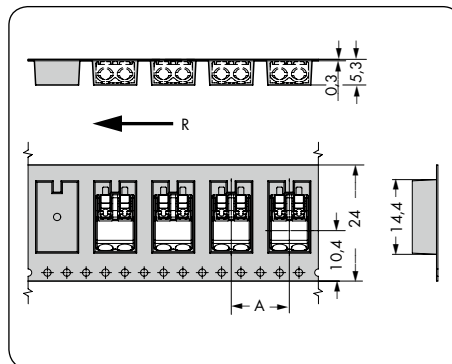

R = Feed direction
A = (pole no. x pin spacing) + 4 mm

Pole No.	Item No.	Pack. Unit
SMD terminal blocks with push-buttons, in tape-and-reel packaging, white*		
1	2060-451/998-404	13500 (9 x 1500)
2	2060-452/998-404	9000 (9 x 1000)
3	2060-453/998-404	6750 (9 x 750)
Reel diameter: 330 mm		



Inserting solid conductors via push-in termination.



Inserting/removing fine-stranded conductors by lightly pressing on push-button (e.g., using a 206-860 operating tool).



Terminal blocks can be arranged side-by-side without loss of poles.

* Depending on reflow soldering temperatures and times, color deviations may occur. These deviations will have no impact on functionality.

SMD Terminal Blocks with Push-Buttons, 0.75 mm² 8 mm Pin Spacing 2060 Series



- SMD terminal blocks with CAGE CLAMP® S and push-buttons
- 8 mm pin spacing version for higher rated voltages
- Push-in termination of solid and ferruled conductors
- Convenient termination/removal of fine-stranded conductors via push-buttons
- Height of just 4.5 mm minimizes on-board LED shadowing
- Available in tape-and-reel packaging for automated assembly

Technical Data

Pin Spacing	8 mm 0.314 in		
Ratings per	IEC/EN 60664-1		
Overtoltage category	III	III	II
Degree of contamination	3	2	2
Rated voltage	400 V	630 V	1000 V
Rated surge voltage	6 kV	6 kV	6 kV
Nominal current	9 A	9 A	9 A
Approvals per	UL 1977		
Rated voltage	600 V		
Nominal current UL	9 A		

Conductor data:

Connection technology	CAGE CLAMP® S
Conductor size: solid	0.2–0.75 mm ²
Conductor size: fine-stranded	0.2–0.75 mm ²
Conductor size: fine-stranded	0.25–0.34 mm ² (with insulated ferrule)
Conductor size: fine-stranded	0.25–0.34 mm ² (with uninsulated ferrule)
AWG	24 – 18
Strip length	7–9 mm / 0.28–0.35 in
Conductor entry	0° to PCB

Material data:

Material group	I
Insulation material	Glass-fiber-reinforced polyphthalamide (PPA-GF)
Flammability rating per UL 94	V0
Lower/Upper limit temperature	-60 °C / +105 °C
Contact material	Copper alloy
Contact plating	Tin-plated

Application note:

Suitable for lead-free, reflow-soldering profiles acc. to DIN EN 61760-1 and IEC 60068-2-58 up to max. 260 °C peak temperature. Due to customer-specific variables (e.g., component configuration and orientation, type of soldering machine, solder paste), trial runs are recommended to ensure product and process compatibility under actual manufacturing conditions.

Recommendation for SMD positioning pattern: Material thickness, 150 µm. Pattern layout identical to solder pad layout.

Current-Carrying Capacity Curve

Pin spacing: 4 mm / Conductor size: 0.75 mm² "f-st"
Based on: EN 60512-5-2 / Reduction factor: 1

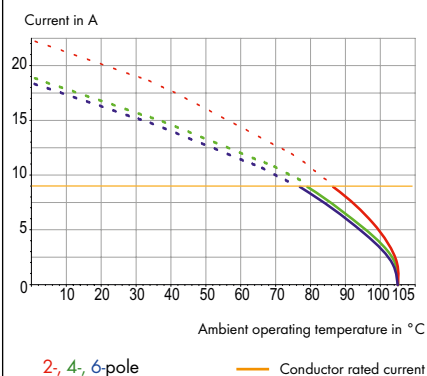

2060 Series accessories:

Page:

Operating tool (206-860)	76
Operating tool (2060-189)	76

Pin spacing 8 mm / 0.314 in		Pin spacing 8 mm / 0.314 in		
0.2-0.75 mm ²	24-18 AWG	0.2-0.75 mm ²	24-18 AWG	
630 V/6 kV/2 9 A		630 V/6 kV/2 9 A		

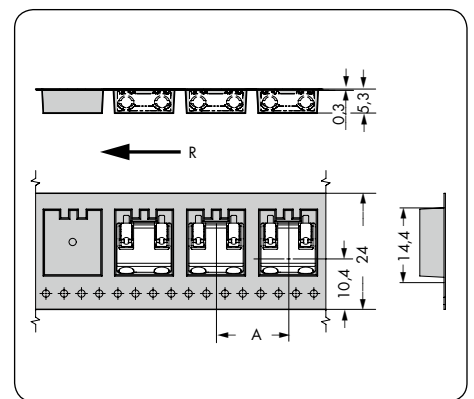
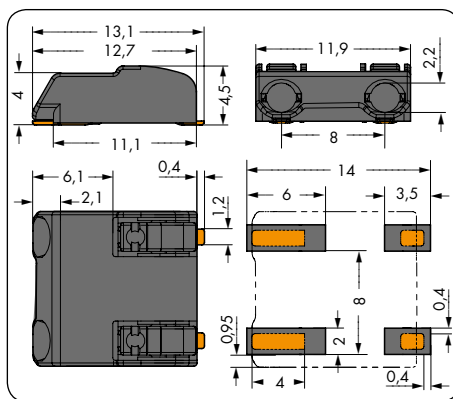
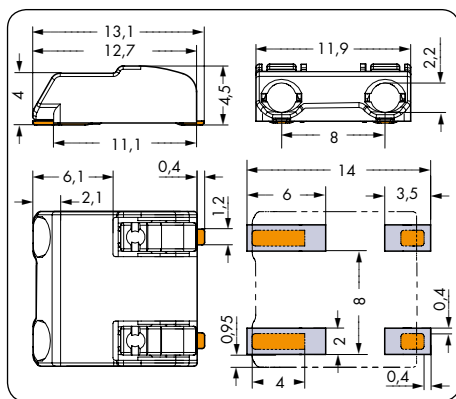

R = Feed direction
A + 16 mm

Pole No.	Item No.	Pack. Unit	Pole No.	Item No.	Pack. Unit
SMD terminal blocks with push-buttons, in tape-and-reel packaging, white*			SMD terminal blocks with push-buttons in tape-and-reel packaging, black*		
2	2060-852/998-404	6750 (9 x 750)	2	2060-872/998-404	6750 (9 x 750)
Reel diameter: 330 mm			Reel diameter: 330 mm		



Inserting solid conductors via push-in termination. (Picture shows 2060 Series)



Inserting/removing fine-stranded conductors by lightly pressing on push-button (e.g., using a 206-860 operating tool).

* Depending on reflow soldering temperatures and times, color deviations may occur. These deviations will have no impact on functionality.

SMD Terminal Blocks with Push-Buttons, 1.5 mm² 6 mm Pin Spacing 2061 Series



- SMD terminal blocks with CAGE CLAMP® S and push-buttons
- Just 5.6 mm high
- Push-in termination of solid and ferruled conductors
- Push-buttons for easy connection and removal of all conductor types
- Available in tape-and-reel packaging for automated assembly

Technical Data

Pin Spacing	6 mm / 0.24 in		
Ratings per	IEC/EN 60664-1		
Overtoltage category	III	III	II
Degree of contamination	3	2	2
Rated voltage	250 V	320 V	630 V
Rated surge voltage	4 kV	4 kV	4 kV
Nominal current	17.5 A	17.5 A	17.5 A
Approvals per	UL		
Use group UL 1059	B	C	D
Rated voltage, 1-pole	600 V	-	600 V
Rated voltage, 2 or more poles	300 V	-	300 V
Nominal current UL	10 A	-	10 A

Conductor data:

Connection technology	CAGE CLAMP® S
Conductor size: solid	0.5–1.5 mm ²
Conductor size: fine-stranded	0.5–1.5 mm ²
Conductor size: fine-stranded	0.5–0.75 mm ² (with insulated ferrule)
Conductor size: fine-stranded	0.5–0.75 mm ² (with uninsulated ferrule)
AWG	20 – 16
Strip length	7–10 mm / 0.28–0.39 in
Conductor entry	0° to PCB

Material data:

Material group	I
Insulation material	Glass-fiber-reinforced polyphthalamide (PPA-GF)
Flammability rating per UL 94	V0
Lower/Upper limit temperature	-60°C / +105°C
Contact material	Copper alloy
Contact plating	Tin-plated

Application note:

Suitable for lead-free, reflow-soldering profiles acc. to DIN EN 61760-1 and IEC 60068-2-58 up to max. 260°C peak temperature. Due to customer-specific variables (e.g., component configuration and orientation, type of soldering machine, solder paste), trial runs are recommended to ensure product and process compatibility under actual manufacturing conditions.

Recommendation for SMD positioning pattern: Material thickness, 150 µm. Stencil layout identical to pad layout.

Current-Carrying Capacity Curve

Pin spacing: 6 mm / Conductor size: 1.5 mm² "f-st"
Based on: EN 60512-5-2 / Reduction factor: 1

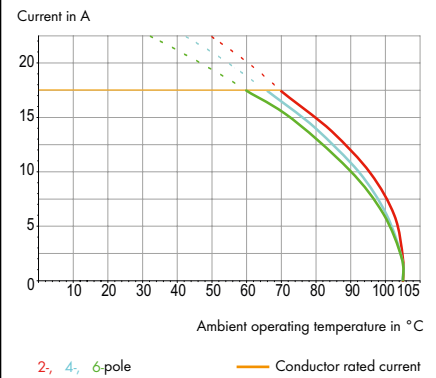

2061 Series accessories:	Page:
Operating tool (206-861)	76
Operating tool (2061-189)	76

SMD Terminal Blocks with Push-Buttons, 1.5 mm²

Pin spacing: 6 mm / 0.24 in 0.5-1.5 mm ² 20-16 AWG 320 V/4 kV/2 17.5 A		Pin spacing: 6 mm / 0.24 in 0.5-1.5 mm ² 20-16 AWG 320 V/4 kV/2 17.5 A	
--	--	--	--

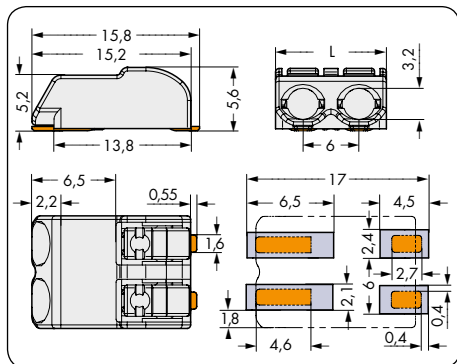

L = (pole no. x pin spacing) + 0.3 mm

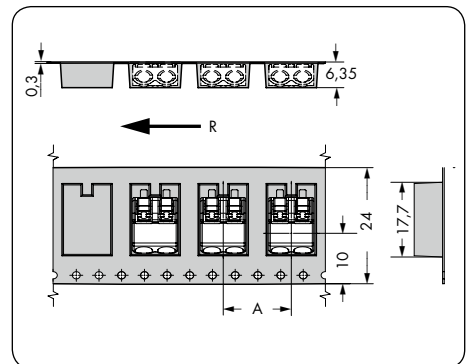
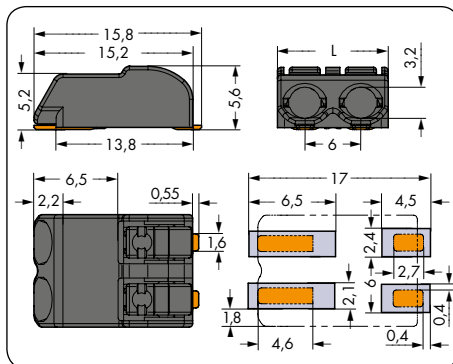

R = Feed direction
 A = 12 mm (1-pole)
 A = 16 mm (2-pole)
 A = 22 mm (3-pole)

Pole No.	Item No.	Pack. Unit	Pole No.	Item No.	Pack. Unit
SMD terminal blocks with push-buttons in tape-and-reel packaging, white*			SMD terminal blocks with push-buttons in tape-and-reel packaging, black*		
1	2061-601/998-404	8100 (9 x 900)	1	2061-621/998-404	8100 (9 x 900)
2	2061-602/998-404	6300 (9 x 700)	2	2061-622/998-404	6300 (9 x 700)
3	2061-603/998-404	4050 (9 x 450)	3	2061-623/998-404	4050 (9 x 450)
Reel diameter: 330 mm			Reel diameter: 330 mm		



Inserting solid conductors via push-in termination.



Inserting/removing fine-stranded conductors by lightly pressing on push-button (e.g., using a 206-861 operating tool).

* Depending on reflow soldering temperatures and times, color deviations may occur for white connectors. These deviations will have no impact on functionality.

SMD Terminal Blocks with Push-Buttons, 0.75 mm² 4 mm Pin Spacing 2060 Series



- SMD terminal blocks with CAGE CLAMP® S and push-buttons
- Push-in termination of solid and ferruled conductors
- Convenient termination/removal of fine-stranded conductors via push-buttons
- Just 4.5 mm high
- Available in tape-and-reel packaging for automated assembly

Technical Data

Pin Spacing	4 mm 0.157 in		
Ratings per	IEC/EN 60664-1		
Overtoltage category	III	III	II
Degree of contamination	3	2	2
Rated voltage	63 V	160 V	320 V
Rated surge voltage	2.5 kV	2.5 kV	2.5 kV
Nominal current	9 A	9 A	9 A
Approvals per	UL 1977		
Rated voltage, 1-pole	600 V		
Rated voltage, 2 or more poles	250 V		
Nominal current UL	9 A		

Conductor data:

Connection technology	CAGE CLAMP® S
Conductor size: solid	0.2–0.75 mm ²
Conductor size: fine-stranded	0.2–0.75 mm ²
Conductor size: fine-stranded	0.25–0.34 mm ² (with insulated ferrule)
Conductor size: fine-stranded	0.25–0.34 mm ² (with uninsulated ferrule)
AWG	24 – 18
Strip length	7–9 mm / 0.28–0.35 in
Conductor entry	0° to PCB

Material data:

Material group	I
Insulation material	Glass-fiber-reinforced polyphthalamide (PPA-GF)
Flammability rating per UL 94	V0
Lower/Upper limit temperature	-60 °C / +105 °C
Contact material	Copper alloy
Contact plating	Tin-plated

Application note:

Suitable for lead-free, reflow-soldering profiles acc. to DIN EN 61760-1 and IEC 60068-2-58 up to max. 260 °C peak temperature. Due to customer-specific variables (e.g., component configuration and orientation, type of soldering machine, solder paste), trial runs are recommended to ensure product and process compatibility under actual manufacturing conditions.

Recommendation for SMD positioning pattern: Material thickness, 150 µm. Pattern layout identical to solder pad layout.

Current-Carrying Capacity Curve

Pin spacing: 4 mm / Conductor size: 0.75 mm² "f-st"
Based on: EN 60512-5-2 / Reduction factor: 1

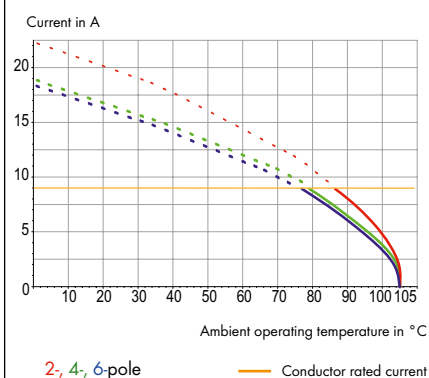

2060 Series accessories:

Page:

Operating tool (206-860)	76
Operating tool (2060-189)	76

Pin spacing 4 mm / 0.157 in	
0.2-0.75 mm ² 160 V/2.5 kV/2 9 A	24-18 AWG

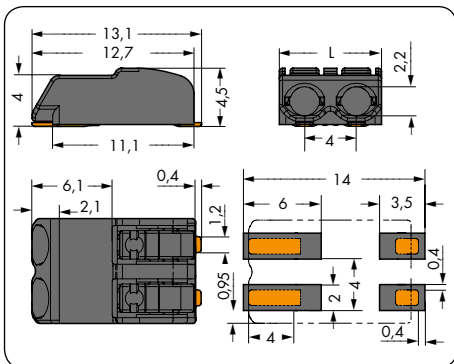

$L = (\text{pole no.} \times \text{pin spacing}) + 0.1 \text{ mm}$

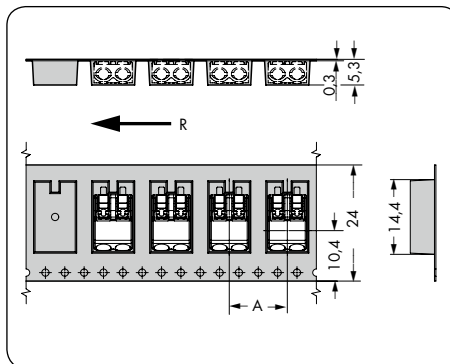

R = Feed direction
A = (pole no. x pin spacing) + 4 mm

Pole No.	Item No.	Pack. Unit
SMD terminal blocks with push-buttons in tape-and-reel packaging, black*		
1	2060-471/998-404	13500 (9 x 1500)
2	2060-472/998-404	9000 (9 x 1000)
3	2060-473/998-404	6750 (9 x 750)
Reel diameter: 330 mm		



Inserting solid conductors via push-in termination.



Inserting/removing fine-stranded conductors by lightly pressing on push-button (e.g., using a 206-860 operating tool).



Terminal blocks can be arranged side-by-side without loss of poles.

SMD Terminal Blocks with Push-Buttons, 0.75 mm² 8 mm Pin Spacing 2060 Series



- SMD terminal blocks with CAGE CLAMP® S and push-buttons
- 8 mm pin spacing version for higher rated voltages
- Push-in termination of solid and ferruled conductors
- Convenient termination/removal of fine-stranded conductors via push-buttons
- Height of just 4.5 mm minimizes on-board LED shadowing
- Available in tape-and-reel packaging for automated assembly

Technical Data

Pin Spacing	8 mm 0.314 in		
Ratings per	IEC/EN 60664-1		
Overtoltage category	III	III	II
Degree of contamination	3	2	2
Rated voltage	400 V	630 V	1000 V
Rated surge voltage	6 kV	6 kV	6 kV
Nominal current	9 A	9 A	9 A
Approvals per	UL 1977		
Rated voltage	600 V		
Nominal current UL	9 A		

Conductor data:

Connection technology	CAGE CLAMP® S
Conductor size: solid	0.2–0.75 mm ²
Conductor size: fine-stranded	0.2–0.75 mm ²
Conductor size: fine-stranded	0.25–0.34 mm ² (with insulated ferrule)
Conductor size: fine-stranded	0.25–0.34 mm ² (with uninsulated ferrule)
AWG	24 – 18
Strip length	6–7 mm / 0.24–0.28 in
Conductor entry	0° to PCB

Material data:

Material group	I
Insulation material	Glass-fiber-reinforced polyphthalamide (PPA-GF)
Flammability rating per UL 94	V0
Lower/Upper limit temperature	-60 °C / +105 °C
Contact material	Copper alloy
Contact plating	Tin-plated

Application note:

Suitable for lead-free, reflow-soldering profiles acc. to DIN EN 61760-1 and IEC 60068-2-58 up to max. 260 °C peak temperature. Due to customer-specific variables (e.g., component configuration and orientation, type of soldering machine, solder paste), trial runs are recommended to ensure product and process compatibility under actual manufacturing conditions.

Recommendation for SMD positioning pattern: Material thickness, 150 µm. Pattern layout identical to solder pad layout.

Current-Carrying Capacity Curve

Pin spacing: 4 mm / Conductor size: 0.75 mm² "f-st"
Based on: EN 60512-5-2 / Reduction factor: 1

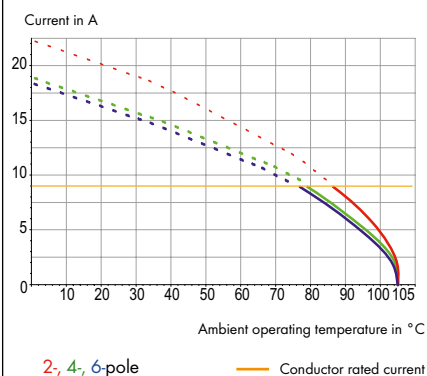

2060 Series accessories:

Page:

Operating tool (206-860)	76
Operating tool (2060-189)	76

Pin spacing 8 mm / 0.314 in	
0.2-0.75 mm ²	24-18 AWG
630 V/6 kV/2 9 A	

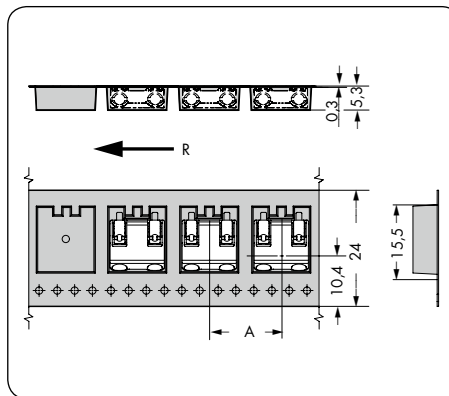
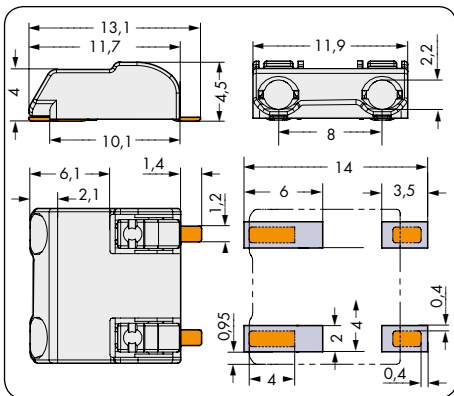

R = Feed direction
A + 16 mm

Pole No.	Item No.	Pack. Unit
SMD terminal blocks with push-buttons in tape-and-reel packaging, light gray*		
2	2060-802/998-404	6750 (9 x 750)
Reel diameter: 330 mm		



Inserting solid conductors via push-in termination. (Picture shows 2060 Series)



Inserting/removing fine-stranded conductors by lightly pressing on push-button (e.g., using a 206-860 operating tool).

THR Terminal Blocks with Push-Buttons, 0.75 mm² 4 mm Pin Spacing 2060 Series



- THR terminal blocks with CAGE CLAMP® S and push-buttons
- Push-in termination of solid and ferruled conductors
- Convenient termination/removal of fine-stranded conductors via push-buttons
- Just 4.5 mm high
- Available in tape-and-reel packaging for automated assembly
- Also suitable for wave soldering

Technical Data

Pin Spacing	4 mm 0.157 in		
Ratings per	IEC/EN 60664-1		
Overtoltage category	III	III	II
Degree of contamination	3	2	2
Rated voltage	63 V	160 V	320 V
Rated surge voltage	2.5 kV	2.5 kV	2.5 kV
Nominal current	9 A	9 A	9 A

Conductor data:

Connection technology	CAGE CLAMP® S
Conductor size: solid	0.2 – 0.75 mm ²
Conductor size: fine-stranded	0.2 – 0.75 mm ²
Conductor size: fine-stranded	0.25 – 0.34 mm ² (with insulated ferrule)
Conductor size: fine-stranded	0.25 – 0.34 mm ² (with uninsulated ferrule)
AWG	24 – 18
Strip length	6–7 mm / 0.24–0.28 in
Conductor entry	0° to PCB
Solder pin: length/width	2.4 mm / 1.2 x 0.75 mm
Solder pin: metal-plated hole	1.5 ^{+0.1} mm Ø
Outer diameter of metal-plated PCB hole	min. 2.4 mm

Material data:

Material group	I
Insulation material	Glass-fiber-reinforced polyphthalamide (PPA-GF)
Flammability rating per UL 94	V0
Lower/Upper limit temperature	-60 °C / +105 °C
Contact material	Copper alloy
Contact plating	Tin-plated

Application note:

Suitable for lead-free, reflow-soldering profiles acc. to DIN EN 61760-1 and IEC 60068-2-58 up to max. 260 °C peak temperature. Due to customer-specific variables (e.g., component configuration and orientation, type of soldering machine, solder paste), trial runs are recommended to ensure product and process compatibility under actual manufacturing conditions.

Recommendation for SMD positioning pattern: Material thickness, 150 µm.
The stencil hole diameter is identical to the outer diameter of the metal-plated PCB hole.

Current-Carrying Capacity Curve

Pin spacing: 4 mm / Conductor size: 0.75 mm² "f-st"
Based on: EN 60512-5-2 / Reduction factor: 1

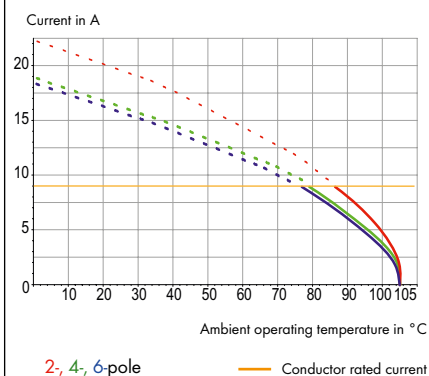

2060 Series accessories:

Page:

Operating tool (206-860)	76
Operating tool (2060-189)	76

Pin spacing 4 mm / 0.157 in		Pin spacing 4 mm / 0.157 in	
0.2-0.75 mm ²	24-18 AWG	0.2-0.75 mm ²	24-18 AWG
160 V/2.5 kV/2 9 A		160 V/2.5 kV/2 9 A	

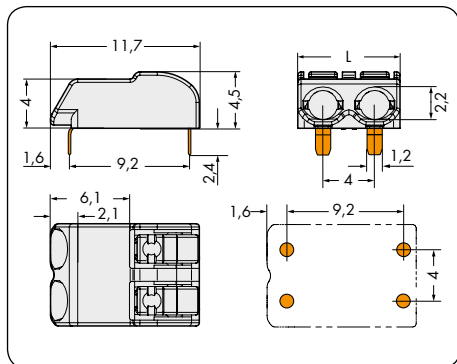

L = (pole no. x pin spacing) + 0.1 mm

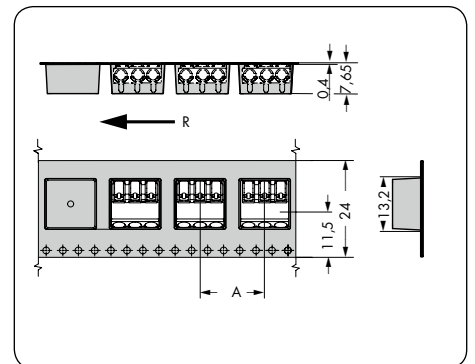
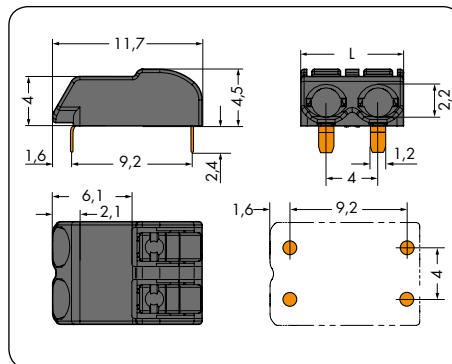

R = Feed direction
A = (pole no. x pin spacing) + 4 mm

Pole No.	Item No.	Pack. Unit	Pole No.	Item No.	Pack. Unit
THR terminal blocks with push-buttons in tape-and-reel packaging, light gray*			THR terminal blocks with push-buttons in tape-and-reel packaging, black*		
1	2060-1401/998-404	10800 (9 x 1200)	1	2060-1421/998-404	10800 (9 x 1200)
2	2060-1402/998-404	6750 (9 x 750)	2	2060-1422/998-404	6750 (9 x 750)
3	2060-1403/998-404	4950 (9 x 550)	3	2060-1423/998-404	4950 (9 x 550)
Reel diameter: 330 mm			Reel diameter: 330 mm		



Inserting solid conductors via push-in termination.



Inserting/removing fine-stranded conductors by lightly pressing on push-button (e.g., using a 206-860 operating tool).



Terminal blocks can be arranged side-by-side without loss of poles.

* Depending on reflow soldering temperatures and times, color deviations may occur. These deviations will have no impact on functionality.

THR Terminal Blocks with Push-Buttons, 0.75 mm² 8 mm Pin Spacing 2060 Series



- THR terminal blocks with CAGE CLAMP® S and push-buttons
- Push-in termination of solid and ferruled conductors
- Convenient termination/removal of fine-stranded conductors via push-buttons
- Just 4.5 mm high
- Available in tape-and-reel packaging for automated assembly
- Also suitable for wave soldering

Technical Data

Pin Spacing	8 mm 0.314 in		
Ratings per	IEC/EN 60664-1		
Overtoltage category	III	III	II
Degree of contamination	3	2	2
Rated voltage	400 V	630 V	1000 V
Rated surge voltage	6 kV	6 kV	6 kV
Nominal current	9 A	9 A	9 A

Conductor data:

Connection technology	CAGE CLAMP® S
Conductor size: solid	0.2 – 0.75 mm ²
Conductor size: fine-stranded	0.2 – 0.75 mm ²
Conductor size: fine-stranded	0.25 – 0.34 mm ² (with insulated ferrule)
Conductor size: fine-stranded	0.25 – 0.34 mm ² (with uninsulated ferrule)
AWG	24 – 18
Strip length	6–7 mm / 0.24–0.28 in
Conductor entry	0° to PCB
Solder pin: length/width	2.4 mm / 1.2 x 0.75 mm
Solder pin: metal-plated hole	1.5 ^{+0.1} mm Ø
Outer diameter of metal-plated PCB hole	min. 2.4 mm

Material data:

Material group	I
Insulation material	Glass-fiber-reinforced polyphthalamide (PPA-GF)
Flammability rating per UL 94	V0
Lower/Upper limit temperature	-60 °C / +105 °C
Contact material	Copper alloy
Contact plating	Tin-plated

Application note:

Suitable for lead-free, reflow-soldering profiles acc. to DIN EN 61760-1 and IEC 60068-2-58 up to max. 260 °C peak temperature. Due to customer-specific variables (e.g., component configuration and orientation, type of soldering machine, solder paste), trial runs are recommended to ensure product and process compatibility under actual manufacturing conditions.

Recommendation for SMD positioning pattern: Material thickness, 150 µm.
The stencil hole diameter is identical to the outer diameter of the metal-plated PCB hole.

Current-Carrying Capacity Curve

Pin spacing: 4 mm / Conductor size: 0.75 mm² "f-st"
Based on: EN 60512-5-2 / Reduction factor: 1

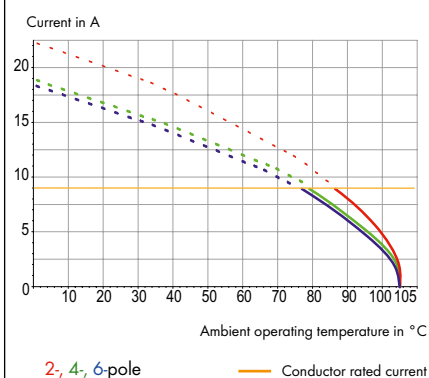

2060 Series accessories:

Page:

Operating tool (206-860)	76
Operating tool (2060-189)	76

Pin spacing 8 mm / 0.314 in		Pin spacing 8 mm / 0.314 in		
0.2-0.75 mm ²	24-18 AWG	0.2-0.75 mm ²	24-18 AWG	
630 V/6 kV/2 9 A		630 V/6 kV/2 9 A		

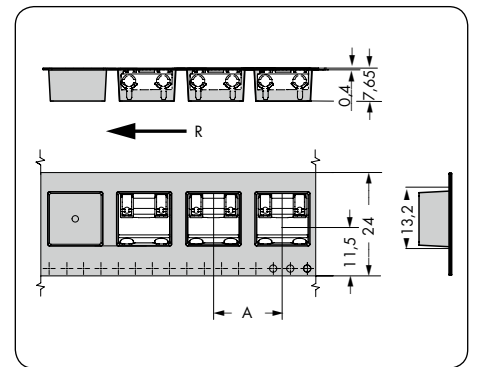
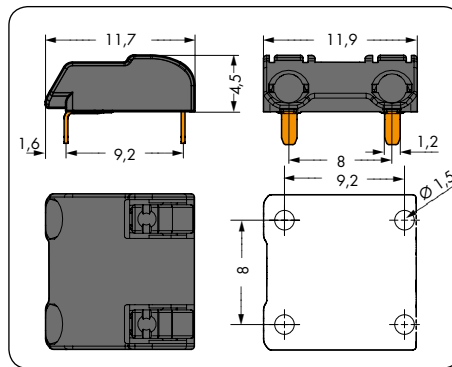
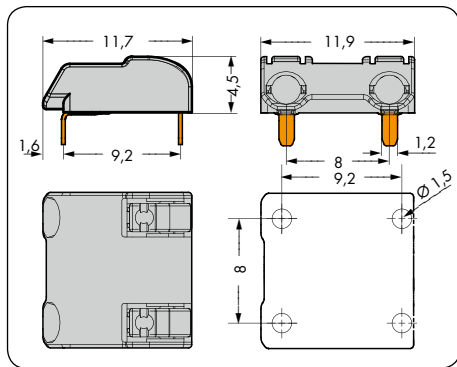

R = Feed direction
A + 16 mm

Pole No.	Item No.	Pack. Unit	Pole No.	Item No.	Pack. Unit
THR terminal blocks with push-buttons in tape-and-reel packaging, light gray*			THR terminal blocks with push-buttons in tape-and-reel packaging, black*		
2	2060-1802/998-404	4950 (9 x 550)	2	2060-1822/998-404	4950 (9 x 550)
Reel diameter: 330 mm			Reel diameter: 330 mm		



Inserting solid conductors via push-in termination.



Inserting/removing fine-stranded conductors by lightly pressing on push-button (e.g., using a 206-860 operating tool).

Board-to-Board Links for SMD Terminal Blocks with Push-Buttons, 0.75 mm², 4 mm Pin Spacing 2060 Series



- Board-to-board link simplifies in-line assembly of LED modules
- Easy push-in termination and disconnection without push-button actuation

Technical Data

Pin Spacing	4 mm 0.157 in				
Ratings per	IEC/EN 60664-1				
Overvoltage category	III	III	II		
Degree of contamination	3	2	2		
Rated voltage	63 V	160 V	320 V		
Rated surge voltage	2.5 kV	2.5 kV	2.5 kV		
Nominal current	9 A	9 A	9 A		
Approvals per	UL/CSA				
Rated voltage	250 V				
Nominal current UL	9 A				

Material data:

Material group	I
Insulation material	Polyamide 6.6 (PA 6.6)
Flammability rating per UL 94	V0
Lower/Upper limit temperature	-60 °C / +105 °C
Contact material	Copper alloy
Contact plating	Silver-plated

Board-to-Board Links for SMD Terminal Blocks with Push-Buttons, 0.75 mm²

Pin spacing 4 mm / 0.157 in	
160 V/2.5 kV/2 9 A	250 V/9 A

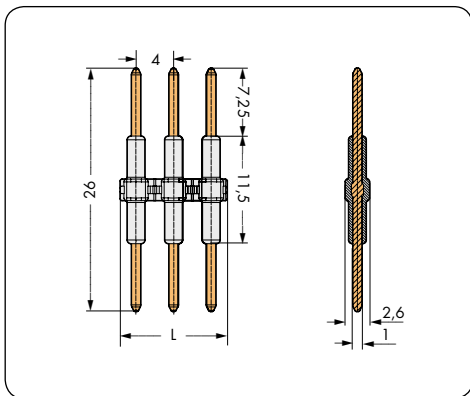
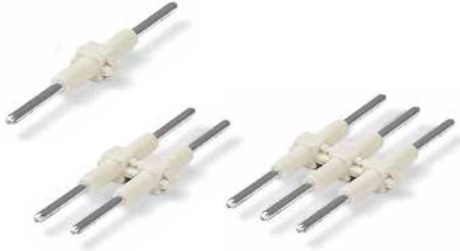

$L = (\text{pole no.} \times \text{pin spacing}) + 0.6 \text{ mm}$

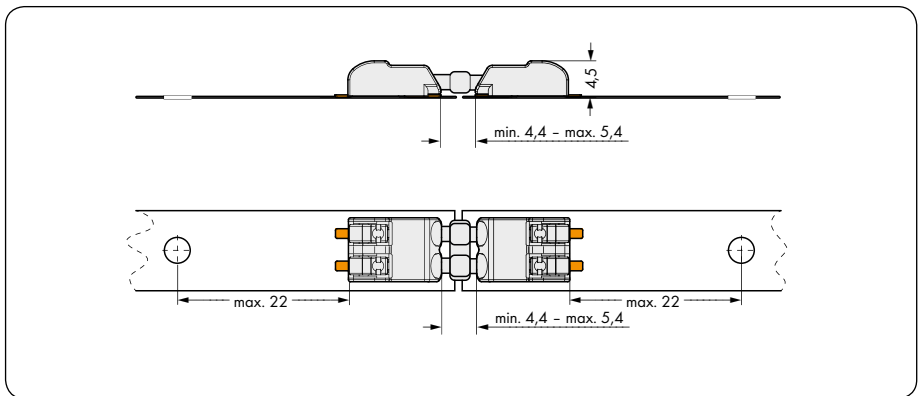

Pole No.	Item No.	Pack. Unit
Board-to-board link for SMD terminal blocks with push-buttons		
1	2060-901	1500
2	2060-902	500
3	2060-903	375

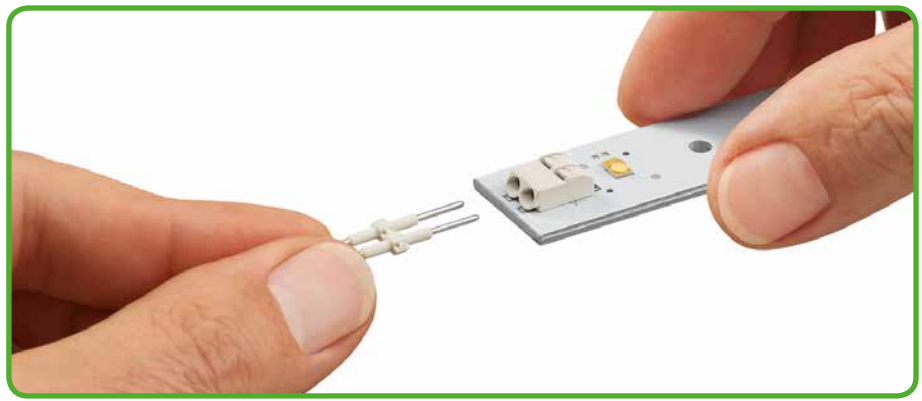

Inserting board-to-board link into terminal block.

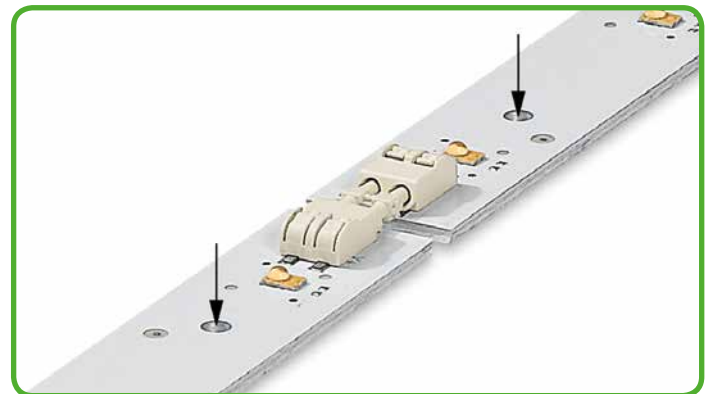
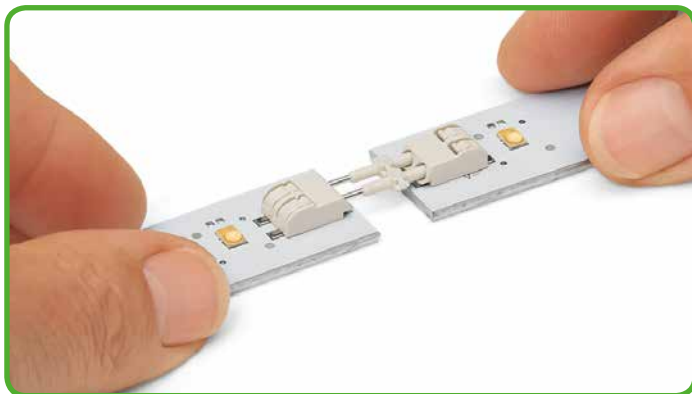

Assembly: Place PCBs on a flat surface and insert links into terminal blocks on adjoining PCBs.

Disassembly: Pull PCBs apart.

(max. 10 connections/disconnections)

The PCBs must be secured (see figure above).

Operating Tools

Operating Tools	Operating Tools Insulated	
-----------------	------------------------------	--



Item No.	Pack. Unit	Item No.	Pack. Unit
Operating tool, suitable for 2059, 2060 and 2061 Series		Operating tool, insulated, suitable for 2059, 2060 and 2061 Series	
for 2059 Series	206-859	5	
for 2060 Series	206-860	5	
for 2061 Series	206-861	5	
		for 2059 Series	2059-189 600 (12 x 50)
		for 2060 Series	2060-189 300 (6 x 50)
		for 2061 Series	2061-189 300 (6 x 50)



Inserting/removing fine-stranded conductors by lightly pressing on push-button.

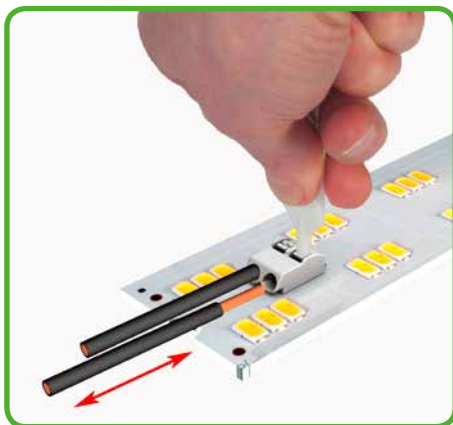

Inserting/removing fine-stranded conductors by lightly pressing on push-button.



1 THR* Terminal Blocks with Push-Buttons

3.5 mm Pin Spacing

2081 Series

78



- Integration of high-temperature resistant THR* terminal blocks into SMT Reflow soldering processes
- Tape-and-reel packaging for automated assembly available on request
- Simple, push-in termination of solid and ferruled conductors
- Convenient termination/removal of fine-stranded conductors via push-buttons
- Versions with alternating soldering pins available for higher voltage levels

Technical Data

Pin Spacing	Solder pins, in line 3.5 mm / 0.138 in			Solder pins, staggered 3.5 mm / 0.138 in		
	IEC/EN 60664-1			IEC/EN 60664-1		
Ratings per	III	III	II	III	III	II
Overtoltage category	3	2	2	3	2	2
Degree of contamination	3	2	2	3	2	2
Rated voltage	160 V	160 V	320 V	250 V	320 V	630 V
Rated surge voltage	2.5 kV	2.5 kV	2.5 kV	4 kV	4 kV	4 kV
Nominal current	17.5 A	17.5 A	17.5 A	17.5 A	17.5 A	17.5 A
Approvals per	UL/CSA**			UL/CSA**		
Use group UL 1059	B	C	D	B	C	D
Rated voltage						
Nominal current UL						
Nominal current CSA						

Conductor and solder pin data:

Connection technology	CAGE CLAMP® S
Conductor size: solid	0.2-1.5 mm ²
Conductor size: fine-stranded	0.2-1.5 mm ²
Conductor size: fine-stranded	0.75 mm ² (with insulated ferrule)
Conductor size: fine-stranded	1.0 mm ² (with uninsulated ferrule)
AWG	24 - 16
Strip length	8-9 mm
Conductor entry	90° to PCB
Solder pin: length/width	2.4 mm / 0.4 x 0.75 mm
Solder pin: drilled hole diameter	1.0 ^{+0.1} mm

Material data:

Material group	I
Insulation material	Glass-fiber-reinforced polyphthalamide (PPA-GF)
Flammability rating per UL 94	V0
Lower/Upper limit temperature	-60 °C / +105 °C
Clamping spring material	Chrome nickel spring steel (CrNi)
Contact material	Electrolytic copper (E _{cu})
Contact plating	Tin-plated

2081 Series accessories:

Volume 2/Page:

Operating Tools	526 - 528
Test pin	538

THR* terminal blocks with push-buttons, in tape-and-reel packaging

With angled, in-line solder pins Pin spacing: 3.5 mm / 0.138 in		With angled, staggered solder pins Pin spacing: 3.5 mm / 0.138 in		With straight, staggered solder pins Pin spacing: 3.5 mm / 0.138 in	
0.2-1.5 mm ²	24-16 AWG	0.2-1.5 mm ²	24-16 AWG	0.2-1.5 mm ²	24-16 AWG
160 V/2.5 kV/2	17.5 A	320 V/4 kV/2	17.5 A	320 V/4 kV/2	17.5 A

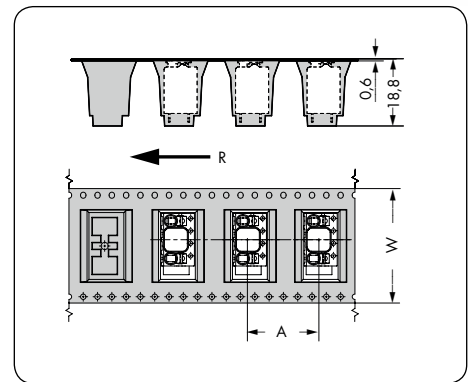
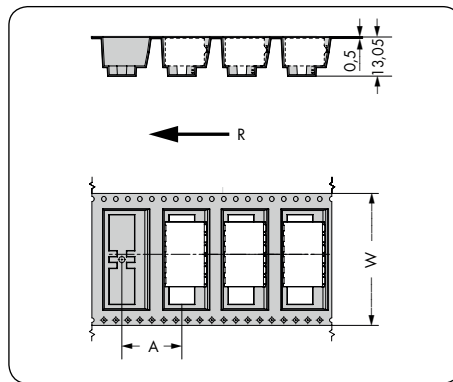
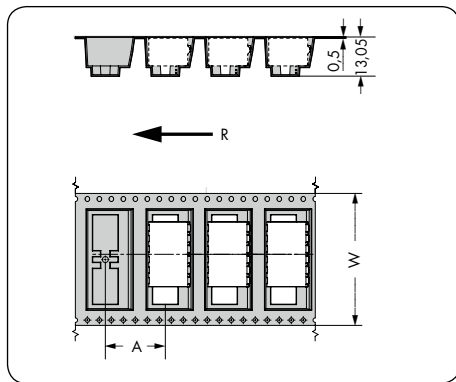

R = Feed direction
A = 20 mm

Pole No.	Item No.	W	Pole No.	Item No.	W	Pole No.	Item No.	W
THR terminal blocks with push-buttons, with angled, in-line solder pins, in tape-and-reel packaging acc. to IEC 60286-3, black			THR* terminal blocks with push-buttons, with angled, staggered solder pins, in tape-and-reel packaging acc. to IEC 60286-3, black			THR* terminal blocks with push-buttons, with angled, straight solder pins, in tape-and-reel packaging acc. to IEC 60286-3, black		
3	2081-1203/200-604/997-404	24	3	2081-1223/200-604/997-404	24	3	2081-1123/200-604/997-405	32
4	2081-1204/200-604/997-404	24	4	2081-1224/200-604/997-404	24	4	2081-1124/200-604/997-405	32
5	2081-1205/200-604/997-406	44	5	2081-1225/200-604/997-406	44	5	2081-1125/200-604/997-405	32
6	2081-1206/200-604/997-406	44	6	2081-1226/200-604/997-406	44			
8	2081-1208/200-604/997-406	44	8	2081-1228/200-604/997-406	44			
Reel diameter: 330 mm, 230 pieces per reel			Reel diameter: 330 mm, 230 pieces per reel			Reel diameter: 330 mm, 150 pieces per reel		

THR* Terminal Blocks with Push-Buttons, 1,5 mm² 3.5 mm Pin Spacing 805 Series



- THR* terminal blocks with with push-button actuated CAGE CLAMP® S
- Simple, push-in terminations of solid and ferruled conductors
- Flush-mount push-buttons that close with minimal force for convenient termination/removal of fine-stranded conductors
- Convenient, tool-free operation

Technical Data

Pin Spacing	3.5 mm 0.138 in		
Ratings per	IEC/EN 60664-1		
Overtoltage category	III	III	II
Degree of contamination	3	2	2
Rated voltage	200 V	320 V	320 V
Rated surge voltage	4 kV	4 kV	4 kV
Nominal current	17.5 A	17.5 A	17.5 A
Approvals per	UL/CSA		
Use group UL 1059	B	C	D
Rated voltage	-	-	-
Nominal current UL	-	-	-
Nominal current CSA	-	-	-

Conductor and solder pin data:

Connection technology	CAGE CLAMP® S
Conductor size: solid	0.2-1.5 mm ²
Conductor size: fine-stranded	0.2-1.5 mm ²
Conductor size: fine-stranded	0.25-1 mm ² (with insulated ferrule)
Conductor size: fine-stranded	0.25-1 mm ² (with uninsulated ferrule)
AWG	24 - 16
Strip length	9-10 mm / 0.35-0.39 in
Conductor entry	0° to PCB
Solder pin: length/width	2.2 mm / 0.5 x 0.75 mm
Solder pin: metal-plated hole	1.1 ^{+0.1} mm Ø

Material data:

Material group	III a
Insulation material	Polyamide 4.6 (PA 4.6)
Flammability rating per UL 94	V2
Lower/Upper limit temperature	-60 °C / +105 °C
Clamping spring material	Chrome nickel spring steel (CrNi)
Contact material	Electrolytic copper (E _{Cu})
Contact plating	Tin-plated

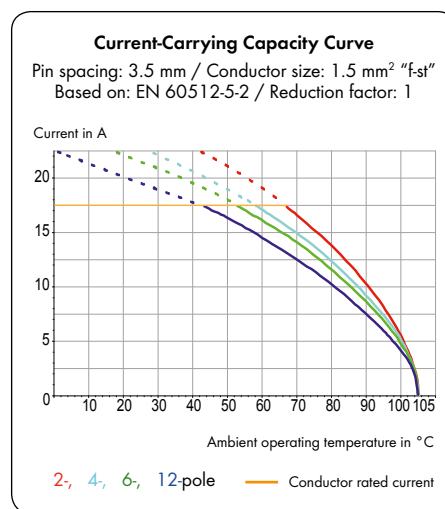

805 Series accessories:

Volume 2/Page:

Marking Accessories	540 - 543
Operating Tools	526 - 528
Test plug	538

Pin spacing: 3.5 mm / 0.138 in		Terminal strips in tape-and-reel packaging Pin spacing: 3.5 mm / 0.138 in		
0.2-1.5 mm ²	24-16 AWG	0.2-1.5 mm ²	24-16 AWG	
320 V/4 kV/2 17.5 A	300 V/10 A	320 V/4 kV/2 17.5 A	300 V/10 A	

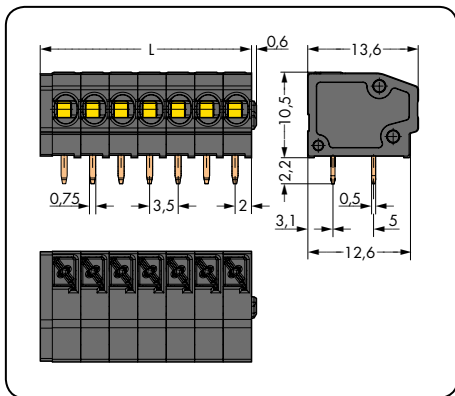

L = (pole no. x pin spacing) + 1.5 mm

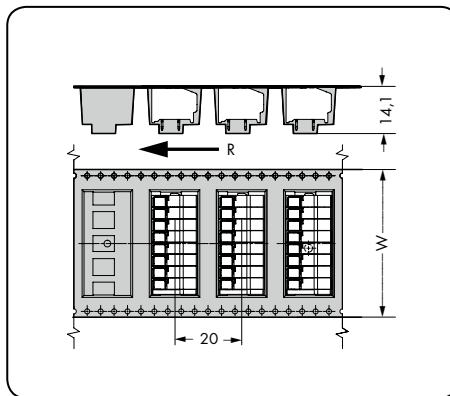

R = Feed direction
W = Tape width

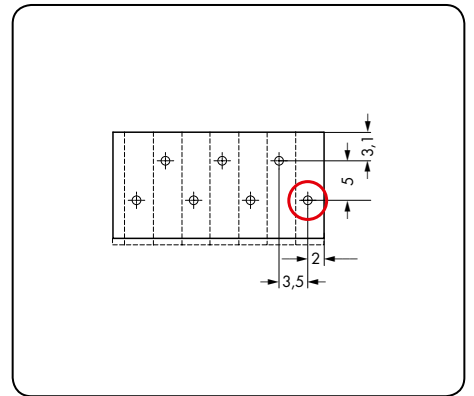

Pole No.	Item No.	PU/SPU	Pole No.	Item No.	W
THR* terminal block with push-buttons, black			THR* terminal block with push-buttons, in tape-and-reel packaging acc. to IEC 60286-3, black		
					(mm)
2	805-302/200-604	600 (4 x 150)	2	805-302/200-604/997-404	24
3	805-303/200-604	420 (4 x 105)	3	805-303/200-604/997-405	32
4	805-304/200-604	300 (4 x 75)	4	805-304/200-604/997-405	32
5	805-305/200-604	260 (4 x 65)	5	805-305/200-604/997-405	32
6	805-306/200-604	220 (4 x 55)	6	805-306/200-604/997-406	44
7	805-307/200-604	180 (4 x 45)	7	805-307/200-604/997-406	44
8	805-308/200-604	160 (4 x 40)	8	805-308/200-604/997-406	44
Reel diameter: 330 mm, 160 pieces per reel					

PCB Terminal Blocks with Push-Buttons, 1.5 mm², 1 In-Line Solder Pin/Pole, Front Side 3.5 mm Pin Spacing 805 Series

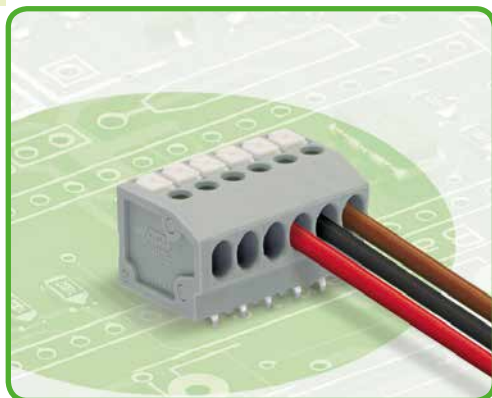

- PCB terminal blocks with with push-button actuated CAGE CLAMP® S
- Version with in-line solder pins
- Simple, push-in terminations of solid and ferruled conductors
- Flush-mount push-buttons that close with minimal force for convenient termination/removal of fine-stranded conductors
- Convenient, tool-free operation
- Versions with/without test slots and spacers
- Versions available with custom internal commoning (factory assembly), e.g., commoning ground conductor

Technical Data

Pin Spacing	3.5 mm 0.138 in		
Ratings per	IEC/EN 60664-1		
Overvoltage category	III	III	II
Degree of contamination	3	2	2
Rated voltage	160 V	160 V	320 V
Rated surge voltage	2.5 kV	2.5 kV	2.5 kV
Nominal current	17.5 A	17.5 A	17.5 A
Approvals per	UL/CSA		
Use group UL 1059	B	C	D
Rated voltage	-	-	-
Nominal current UL	-	-	-
Nominal current CSA	-	-	-

Conductor and solder pin data:

Connection technology	CAGE CLAMP® S
Conductor size: solid	0.2-1.5 mm ²
Conductor size: fine-stranded	0.2-1.5 mm ²
Conductor size: fine-stranded	0.25-1 mm ² (with insulated ferrule)
Conductor size: fine-stranded	0.25-1 mm ² (with uninsulated ferrule)
AWG	24 - 16
Strip length	9-10 mm / 0.35-0.39 in
Conductor entry	0° to PCB
Solder pin: length/width	3.2 mm / 0.5 x 0.75 mm
Solder pin: drilled hole diameter	1.1 ^{+0.1} mm

Material data:

Material group	I
Insulation material	Polyamide 6.6 (PA 6.6)
Flammability rating per UL 94	V0
Lower/Upper limit temperature	-60 °C / +105 °C
Clamping spring material	Chrome nickel spring steel (CrNi)
Contact material	Electrolytic copper (E _{Cu})
Contact plating	Tin-plated

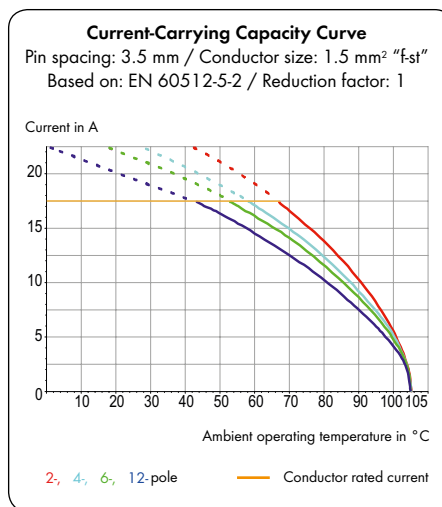

805 Series accessories:

Volume 2/Page:

Marking Accessories	540 - 543
Operating Tools	526 - 528
Test plug	538

PCB Terminal Blocks with Push-Buttons, 1.5 mm² 1 In-Line Solder Pin/Pole, Front Side

With test slots Pin spacing: 3.5 mm / 0.138 in		Pin spacing: 3.5 mm / 0.138 in		
0.2-1.5 mm ²	24-16 AWG	0.2-1.5 mm ²	24-16 AWG	
320 V/4 kV/2 17.5 A	300 V/10 A	320 V/4 kV/2 17.5 A	300 V/10 A	

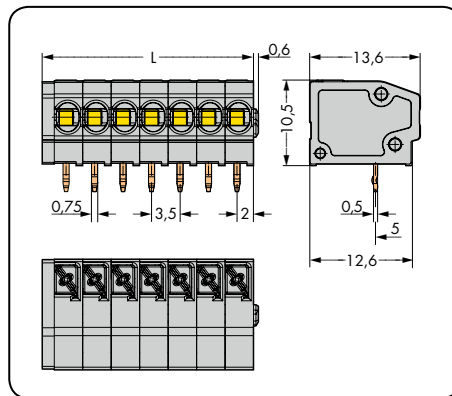
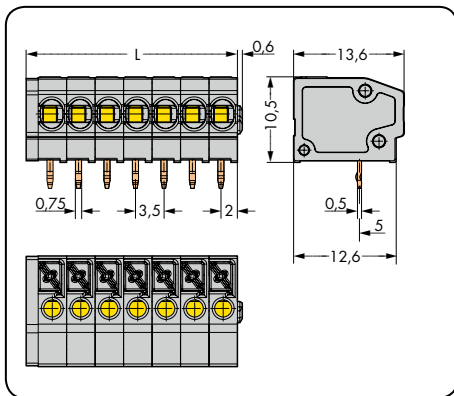

L = (pole no. x pin spacing) + 1.5 mm

Pole No.	Item No.	Pack. Unit	Pole No.	Item No.	Pack. Unit
PCB terminal block with push-buttons, 1 in-line solder pin/pole, front side, test slots for 2 mm Ø test plug, gray			PCB terminal block with push-buttons, 1 in-line solder pin/pole, front side, gray		
2	805-152	600 (4 x 150)	2	805-352	600 (4 x 150)
3	805-153	420 (4 x 105)	3	805-353	420 (4 x 105)
4	805-154	320 (4 x 80)	4	805-354	300 (4 x 75)
5	805-155	260 (4 x 65)	5	805-355	260 (4 x 65)
6	805-156	220 (4 x 55)	6	805-356	220 (4 x 55)
7	805-157	180 (4 x 45)	7	805-357	180 (4 x 45)
8	805-158	160 (4 x 40)	8	805-358	160 (4 x 40)
9	805-159	140 (4 x 35)	9	805-359	140 (4 x 35)
10	805-160	120 (4 x 30)	10	805-350	120 (4 x 30)
11	805-161	100 (4 x 25)	11	805-361	100 (4 x 25)
12	805-162	100 (4 x 25)	12	805-362	100 (4 x 25)
13	805-163	100 (4 x 25)	13	805-363	100 (4 x 25)
14	805-164	100 (4 x 25)	14	805-364	100 (4 x 25)
15	805-165	80 (4 x 20)	15	805-365	80 (4 x 20)
16	805-166	80 (4 x 20)	16	805-366	80 (4 x 20)
17	805-167	80 (4 x 20)	17	805-367	80 (4 x 20)
18	805-168	60 (4 x 15)	18	805-368	60 (4 x 15)
19	805-169	60 (4 x 15)	19	805-369	60 (4 x 15)
20	805-170	60 (4 x 15)	20	805-370	60 (4 x 15)
21	805-171	60 (4 x 15)	21	805-371	60 (4 x 15)
22	805-172	60 (4 x 15)	22	805-372	60 (4 x 15)
23	805-173	60 (4 x 15)	23	805-373	60 (4 x 15)
24	805-174	40 (4 x 10)	24	805-374	40 (4 x 10)

Item no. suffixes for colored PCB terminal blocks (production and prices depend on quantity required):

● blue	.../000-006	Ordering example: PCB terminal block, 3.5 mm pin spacing, 6-pole, blue: 805-356/000-006
● orange	.../000-012	

Please contact factory for other lengths, colors, direct printing, or mixed-color PCB terminal blocks.

PCB Terminal Blocks with Push-Buttons, 0.5 mm², 1 In-Line Solder Pin/Pole, Front Side 2.5 mm Pin Spacing 250 Series

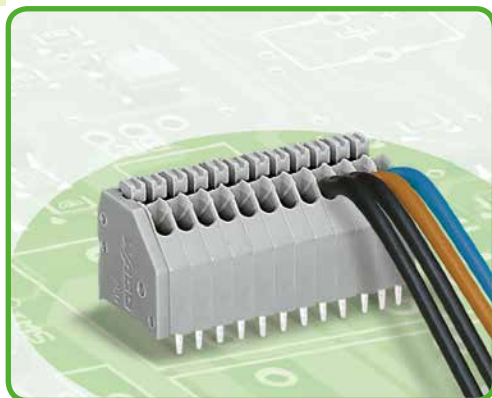

- Compact PCB terminal blocks with push-buttons
- Version with in-line solder pins
- Simple push-in termination for solid conductors
- Termination/removal of fine-stranded conductors via push-buttons
- 45° conductor entry angle provides easy, space-saving wiring
- Custom color combinations
- PCB terminal blocks also available with spacers upon request

Technical Data

Pin Spacing	2.5 mm 0.098 in		
Ratings per	IEC/EN 60664-1		
Overtoltage category	III	III	II
Degree of contamination	3	2	2
Rated voltage	100 V	160 V	320 V
Rated surge voltage	2.5 kV	2.5 kV	2.5 kV
Nominal current	4 A	4 A	4 A
Approvals per	UL/CSA		
Use group UL1059	B	C	D
Rated voltage	-	-	-
Nominal current UL	-	-	-
Nominal current CSA	-	-	-

Conductor and solder pin data:

Connection technology	CAGE CLAMP®S
Conductor size: solid	0.14-0.5 mm ² (0.4-0.8 mm Ø)
Conductor size: fine-stranded	0.2-0.5 mm ²
AWG	24 - 20 (26 "sol.")
Strip length	8.5-9.5 mm / 0.32-0.36 in
Conductor entry	45° to PCB
Solder pin: length/width	3.6 mm / 0.4 x 0.75 mm
Solder pin: drilled hole diameter	1.1 ^{-0.1} mm

Material data:

Material group	I
Insulation material	Polyamide 6.6 (PA 6.6)
Flammability rating per UL 94	V0
Lower/Upper limit temperature	-60 °C / +105 °C
Clamping spring material	Copper alloy
Contact plating	Copper

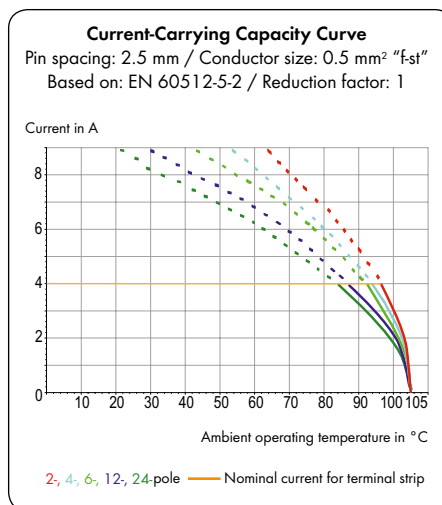

250 Series accessories:

Volume 2/Page:

Marking Accessories	540 - 543
Operating Tools	526 - 528
Test pin	538

PCB Terminal Blocks with Push-Buttons, 0.5 mm² 1 In-Line Solder Pin/Pole, Front Side

Pin spacing: 2.5 mm / 0.098 in			
0.2-0.5 mm ²	24-20 AWG		
160 V/2.5 kV/2 4 A			

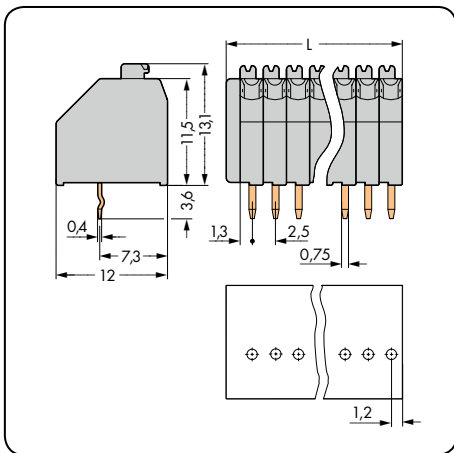

L = (pole no. x pin spacing) + 1.5 mm

Pole No.	Item No.	Pack. Unit	Color	Item No.	Pack. Unit
PCB terminal block with push-buttons, 1 in-line solder pin/pole, front side, gray			Item no. suffixes for colored PCB terminal blocks		
2	250-302	720 (4 x 180)	● black	...-.../000-004	
3	250-303	520 (4 x 130)	● red	...-.../000-005	
4	250-304	400 (4 x 100)	● blue	...-.../000-006	
5	250-305	340 (4 x 85)	○ light gray	...-.../000-009	
6	250-306	280 (4 x 70)	● orange	...-.../000-012	
7	250-307	240 (4 x 60)	● green	...-.../000-023	
8	250-308	220 (4 x 55)	● violet	...-.../000-024	
9	250-309	200 (4 x 50)	○ white	...-.../000-050	
10	250-310	180 (4 x 45)			
11	250-311	160 (4 x 40)	Ordering example:		
12	250-312	140 (4 x 35)	PCB terminal block, 2.5 mm pin spacing		
13	250-313	140 (4 x 35)	8-pole, orange: 250-308/000-012		
14	250-314	120 (4 x 30)	(Production and prices depend on quantity required)		
15	250-315	120 (4 x 30)			
16	250-316	100 (4 x 25)			
17	250-317	100 (4 x 25)			
18	250-318	80 (4 x 20)			
19	250-319	80 (4 x 20)			
20	250-320	80 (4 x 20)			
21	250-321	80 (4 x 20)			
22	250-322	80 (4 x 20)			
23	250-323	80 (4 x 20)			
24	250-324	60 (4 x 15)			

PCB Terminal Blocks with Angled Push-Buttons, 2.5 mm² 5/5.08 mm, 7.5/7.62 mm, 10/10.16 mm Pin Spacing 256 Series



- PCB terminal blocks with push-button actuated CAGE CLAMP®
- New version with angled push-buttons for easy top-of-unit actuation
- Set to metric or inch pin spacing by compressing terminal strips together or pulling them apart
- Ideal for in-the-field wiring thanks to simplified push-button actuation
- Convenient, tool-free operation

Technical Data

Pin Spacing	5/5.08 mm 0.2 in			7.5/7.62 mm 0.3 in			10/10.16 mm 0.4 in		
	IEC/EN 60664-1			IEC/EN 60664-1			IEC/EN 60664-1		
Ratings per									
Overtoltage category	III	III	II	III	III	II	III	III	II
Degree of contamination	3	2	2	3	2	2	3	2	2
Rated voltage	250 V	320 V	630 V	320 V	320 V	630 V	500 V	630 V	1000 V
Rated surge voltage	4 kV	4 kV	4 kV	4 kV	4 kV	4 kV	6 kV	6 kV	6 kV
Nominal current	24 A	24 A	24 A	24 A	24 A	24 A	24 A	24 A	24 A
Approvals per	UL/CSA			UL/CSA			UL/CSA		
Use group UL 1059	B	C	D	B	C	D	B	C	D
Rated voltage	300 V	-	300 V	300 V	-	300 V	300 V	-	300 V
Nominal current UL	15 A	-	10 A	15 A	-	10 A	15 A	-	10 A
Nominal current CSA	15 A	-	10 A	15 A	-	10 A	15 A	-	10 A

Conductor and solder pin data:

Connection technology	CAGE CLAMP®
Conductor size: solid	0.08 - 2.5 mm ²
Conductor size: fine-stranded	0.08 - 2.5 mm ²
Conductor size: fine-stranded	0.25 - 1.5 mm ² (with insulated ferrule)
Conductor size: fine-stranded	0.25 - 1.5 mm ² (with uninsulated ferrule)
AWG	28 - 12 (12: THHN, THWN)
Strip length	5 - 6 mm / 0.20 - 0.24 in
Conductor entry	45° to PCB
Solder pin: length/width	4 mm / 0.7 x 0.7 mm
Solder pin: drilled hole diameter	1.1 ^{+0.1} mm

Material data:

Material group	I
Insulation material	Polyamide 6.6 (PA 6.6)
Flammability rating per UL 94	V0
Lower/Upper limit temperature	-60 °C / +105 °C
Clamping spring material	Chrome nickel spring steel (CrNi)
Contact material	Electrolytic copper (E _{Cu})
Contact plating	Tin-plated

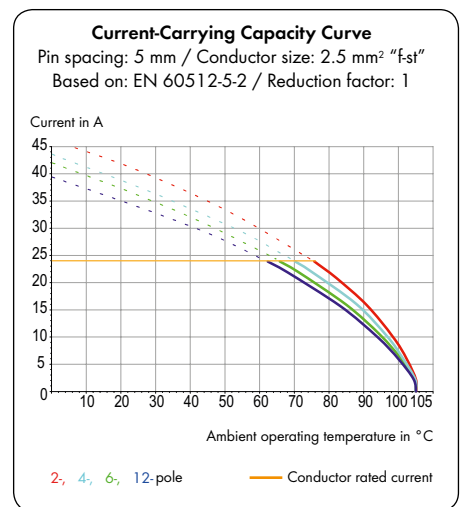

256 Series accessories:

Volume 2/Page:

Marking Accessories	540 - 543
Operating Tools	526 - 528
Commoning strips	67 - 69
Test plug adapter	196

Modular PCB terminal blocks with angled push-buttons, 2.5 mm²

CAGE CLAMP®

Pin spacing: 5/5.08 mm / 0.2 in		Pin spacing: 7.5/7.62 mm / 0.3 in		Pin spacing: 10/10.16 mm / 0.4 in	
0.08-2.5 mm ²	28-12 AWG	0.08-2.5 mm ²	28-12 AWG	0.08-2.5 mm ²	28-12 AWG
320 V/4 kV/2 24 A	300 V/10 A	320 V/4 kV/2 24 A	300 V/10 A	630 V/6 kV/2 24 A	300 V/10 A

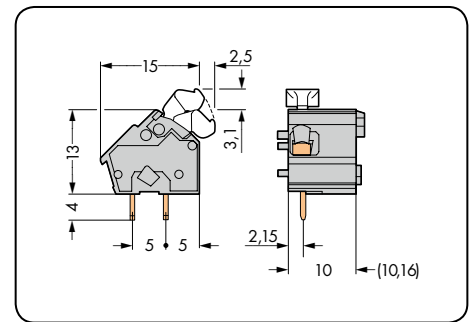
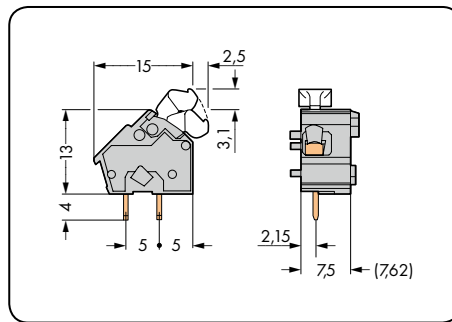
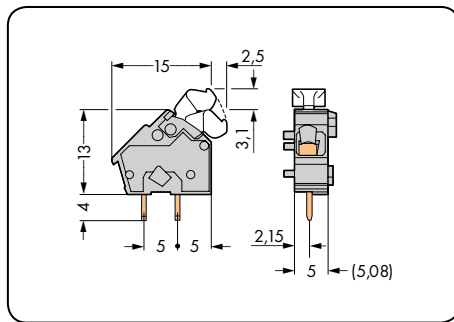

Color	Item No.	Pack. Unit	Color	Item No.	Pack. Unit	Color	Item No.	Pack. Unit
Modular PCB terminal block with angled push-button, 2 solder pins/pole			Modular PCB terminal block with angled push-button, 2 solder pins/pole			Modular PCB terminal block with angled push-button, 2 solder pins/pole		
gray	256-461	600 (6 x 100)	gray	256-561	400 (4 x 100)	gray	256-661	300 (3 x 100)
red	256-840	600 (6 x 100)	red	256-850	400 (4 x 100)	red	256-860	300 (3 x 100)
dark gray	256-842	600 (6 x 100)	dark gray	256-852	400 (4 x 100)	dark gray	256-862	300 (3 x 100)
light gray	256-843	600 (6 x 100)	light gray	256-853	400 (4 x 100)	light gray	256-863	300 (3 x 100)
blue	256-844	600 (6 x 100)	blue	256-854	400 (4 x 100)	blue	256-864	300 (3 x 100)
orange	256-846	600 (6 x 100)	orange	256-856	400 (4 x 100)	orange	256-866	300 (3 x 100)
light green	256-847	600 (6 x 100)	light green	256-857	400 (4 x 100)	light green	256-867	300 (3 x 100)

End plates for 256 Series		Color	Item No.	Pack. Unit
snap-on type, 1 mm/0.039 in thick		gray	256-100	100
		dark gray	256-200	100
		light gray	256-300	100
		blue	256-400	100
		red	256-500	100
		orange	256-600	100
		light green	256-700	100
		black	256-800	100



PCB Terminal Blocks with Angled Push-Buttons, 2.5 mm²

Pin spacing: 5/5.08 mm / 0.2 in		Pin spacing: 7.5/7.62 mm / 0.3 in		Pin spacing: 10/10.16 mm / 0.4 in	
0.08-2.5 mm ²	28-12 AWG	0.08-2.5 mm ²	28-12 AWG	0.08-2.5 mm ²	28-12 AWG
320 V/4 kV/2 24 A	300 V/10 A	320 V/4 kV/2 24 A	300 V/10 A	630 V/6 kV/2 24 A	300 V/10 A

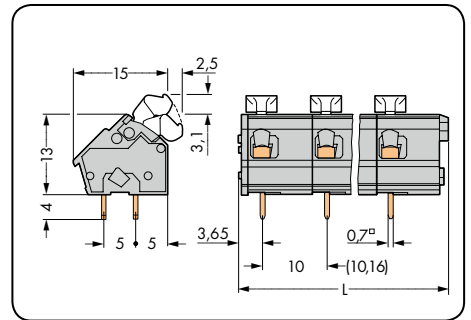
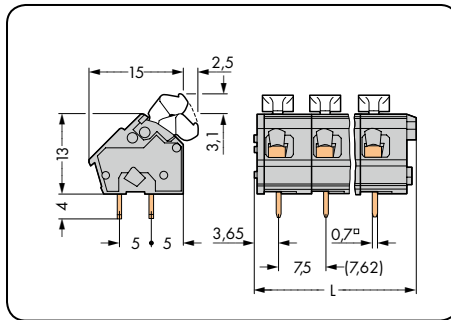
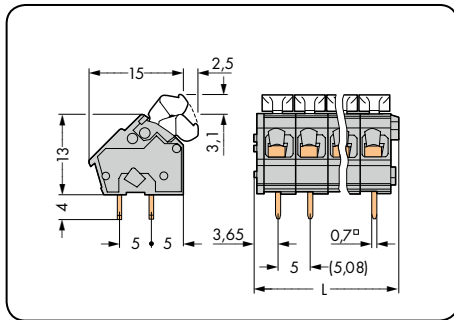
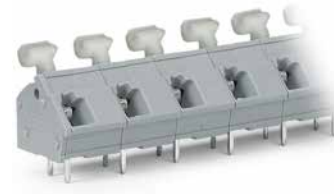
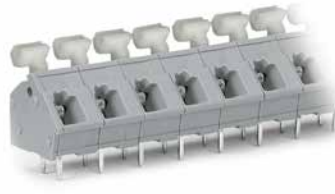

$L = (\text{pole no.} \times \text{pin spacing}) + 2.9 \text{ mm}$

Pole No.	Item No.	Pack. Unit	Pole No.	Item No.	Pack. Unit	Pole No.	Item No.	Pack. Unit
PCB terminal block with angled push-buttons, 2 solder pins/pole, gray			PCB terminal block with angled push-buttons, 2 solder pins/pole, gray			PCB terminal block with angled push-buttons, 2 solder pins/pole, gray		
2	256-402/334-000	400 (4 x 100)	2	256-502/334-000	280 (4 x 70)	2	256-602/334-000	200 (4 x 50)
3	256-403/334-000	280 (4 x 70)	3	256-503/334-000	180 (4 x 45)	3	256-603/334-000	140 (4 x 35)
4	256-404/334-000	200 (4 x 50)	4	256-504/334-000	140 (4 x 35)	4	256-604/334-000	100 (4 x 25)
5	256-405/334-000	160 (4 x 40)	5	256-505/334-000	120 (4 x 30)	5	256-605/334-000	80 (4 x 20)
6	256-406/334-000	140 (4 x 35)	6	256-506/334-000	100 (4 x 25)	6	256-606/334-000	60 (4 x 15)
7	256-407/334-000	120 (4 x 30)	7	256-507/334-000	80 (4 x 20)	7	256-607/334-000	60 (4 x 15)
8	256-408/334-000	100 (4 x 25)	8	256-508/334-000	60 (4 x 15)	8	256-608/334-000	60 (4 x 15)
9	256-409/334-000	100 (4 x 25)	9	256-509/334-000	60 (4 x 15)	9	256-609/334-000	40 (4 x 10)
10	256-410/334-000	80 (4 x 20)	10	256-510/334-000	60 (4 x 15)	10	256-610/334-000	40 (4 x 10)
12	256-412/334-000	60 (4 x 15)	12	256-512/334-000	40 (4 x 10)	12	256-612/334-000	40 (4 x 10)
16	256-416/334-000	60 (4 x 15)	16	256-516/334-000	40 (4 x 10)	16	256-616/334-000	20 (4 x 5)
24	256-424/334-000	40 (4 x 10)	24	256-524/334-000	20 (4 x 5)	24	256-624/334-000	20 (4 x 5)
36	256-436/334-000	20 (4 x 5)						
48	256-448/334-000	20 (4 x 5)						

Item no. suffixes for colored PCB terminal blocks (production and prices depend on quantity required):

● red/000-005	Ordering example: PCB terminal block, 5/5.08 mm pin spacing 8-pole, orange: 256-408/334-012
● blue/000-006	
● dark gray/000-008	
○ light gray/000-009	
● orange/000-012	
● light green/000-017	

Male Headers with 1 x 1 mm Solder Pins, THR (Through-Hole Reflow*)

5.08 mm Pin Spacing

MCS MIDI Classic



- THR male headers for reflow soldering in SMT applications
- Available in tape-and-reel packaging for automated pick-and-place assembly
- Also available in bulk packaging for manual placement
- Male headers may be mounted horizontally or vertically
- Coding pins available

Technical Data

1 x 1 mm

Pin Spacing	5.08 mm 0.2 in		
Ratings per	IEC/EN 60664-1		
Overtoltage category	III	III	II
Degree of contamination	3	2	2
Rated voltage	320 V	320 V	630 V
Rated surge voltage	4 kV	4 kV	4 kV
Nominal current	12 A	12 A	12 A
Approvals per	UL/CSA		
Use group UL 1059	B	C	D
Rated voltage	300 V	-	300 V
Nominal current UL	10 A	-	10 A
Nominal current CSA	10 A	-	10 A

The MCS-MIDI connection system is UL 1977 approved and capable of up to 600 V for factory wiring.

Solder pin data:

Solder pin: length/width	2.4 mm / 1 x 1 mm
Solder pin: drilled hole diameter	1.4 ^{+0.1} mm
For other pin lengths, please contact factory.	

Material data:

Material group	I
Insulation material	Glass-fiber-reinforced polyphthalamide (PPA-GF)
Flammability rating per UL 94	V0
Lower/Upper limit temperature	-60 °C / +100 °C
Contact material	Electrolytic copper (E _{CU})
Contact plating	Tin-plated
MCS connectors are also available upon request with gold-plated or partially gold-plated contact surfaces.	
Depending on the version requested, "item no. suffix ... /010-000" is added to the "basic item no."	

The MULTI CONNECTION SYSTEM (MCS) is designed without breaking capacity for compliance with DIN EN 61984. When used as intended, these connectors shall not be connected/disconnected when live or under load. The circuit design should ensure header pins, which can be touched, are not live when unmated.

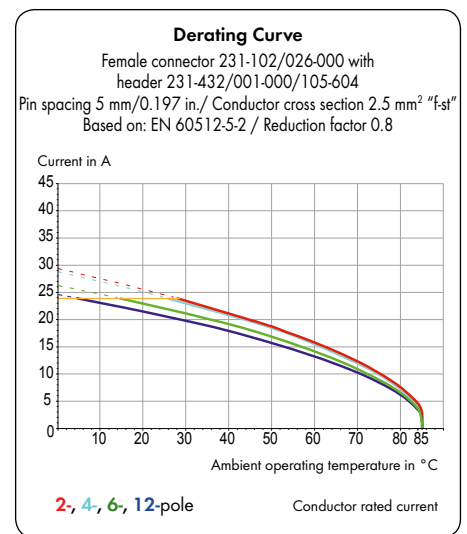

MCS MIDI accessories:

Volume 2/Page:

Separators	468
Coding keys	468
Fixing elements	469

Male Headers with Straight or Angled 1 x 1 mm Solder Pins, THR MCS MIDI Classic

With 1 x 1 mm straight solder pins Pin spacing 5.08 mm / 0.2 in		With 1 x 1 mm angled solder pins Pin spacing 5.08 mm / 0.2 in		With angled 1 x 1 mm solder pins, in tape-and-reel packaging Pin spacing 5.08 mm / 0.2 in	
320 V/4 kV/2 12 A	300 V/10 A	320 V/4 kV/2 12 A	300 V/10 A	320 V/4 kV/2 12 A	300 V/10 A

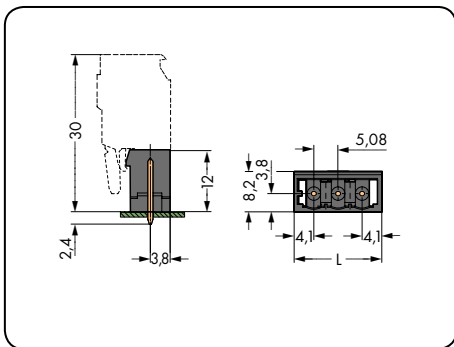

$L = (\text{pole no.} - 1) \times \text{pin spacing} + 8.2 \text{ mm}$

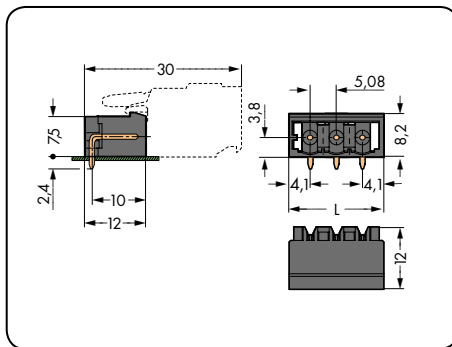

$L = (\text{pole no.} - 1) \times \text{pin spacing} + 8.2 \text{ mm}$

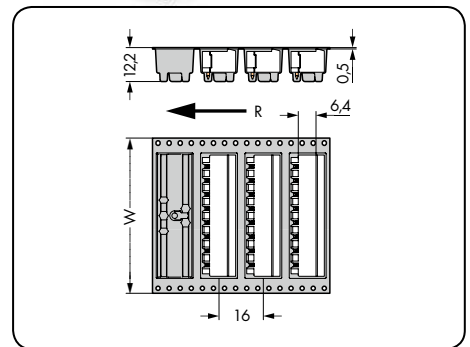

W= Tape width
R = Feed direction

Pole No.	Item No.	Pack. Unit	Pole No.	Item No.	Pack. Unit	Pole No.	Item No.	W
Male header with 1 x 1 mm straight solder pins, black			Male header with 1 x 1 mm angled solder pins, black			Male header with 1 x 1 mm straight solder pins, in tape-and-reel packaging acc. to IEC 60286-3, black		
2	231-332/001-000/105-604	200	2	231-532/001-000/105-604	200	2	231-532/001-000/105-604/997-405	32
3	231-333/001-000/105-604	200	3	231-533/001-000/105-604	200	3	231-533/001-000/105-604/997-405	32
						Reel diameter: 330 mm, 170 pieces per reel		

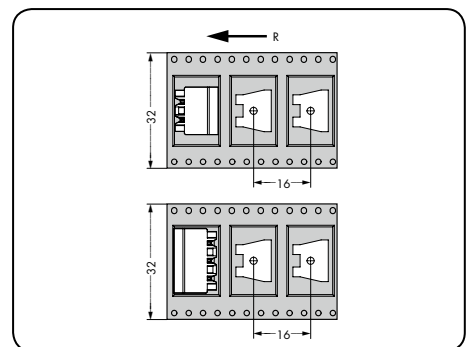

W= Tape width
R = Feed direction

Accessories

Strain Relief Plates

MCS MAXI

Strain relief plate for in-the-field assembly for 2- to 3-pole male and female connectors 831 Series	Strain relief plate for in-the-field assembly for 4- to 6-pole male and female connectors 831 Series	Strain relief plate for in-the-field assembly for 7- to 9-pole male and female connectors 831 Series
---	---	---



Width	Pole No.	Item No.	Pack. Unit	Width	Pole No.	Item No.	Pack. Unit	Width	Pole No.	Item No.	Pack. Unit
Strain relief plate, light gray				Strain relief plate, light gray				Strain relief plate, light gray			
15 mm	2 - 3	831-503	100 (4 x 25)	30 mm	4 - 6	831-505	100 (4 x 25)	51 mm	7 - 9	831-506	100 (4 x 25)

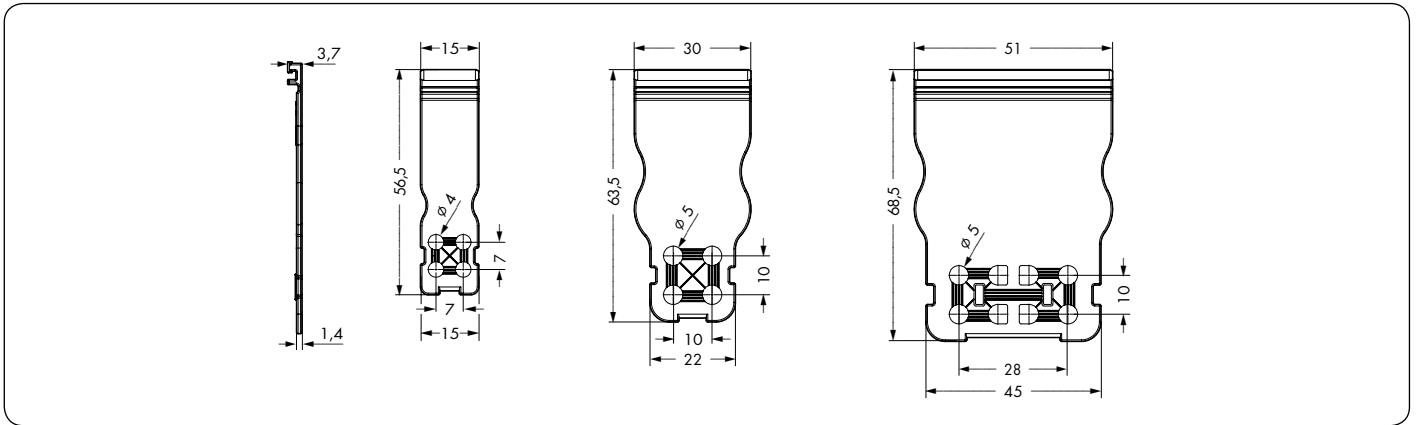

The arrangement of the attachments for cable ties allows single conductors or multi-core cables to be secured in different ways. The width of the cable ties must correspond to the hole dimensions of the strain relief plates shown above.

Cable ties and cable binding tools are not included in the WAGO scope of supply. Refer to the Hellermann company.

1 Modular Empty Housing, 2857 Series

Overview and Configuration

Pluggable connection with *picoMAX*[®]

Fixed connection with *picoMAX*[®]

Empty slot without connection technology

... freely selectable for each connection point

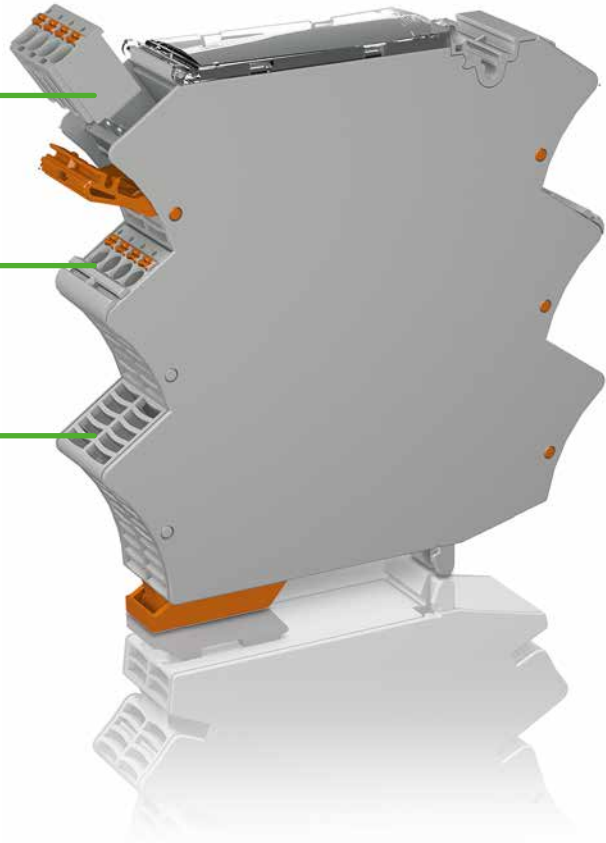

Supplied as a pre-assembled unit

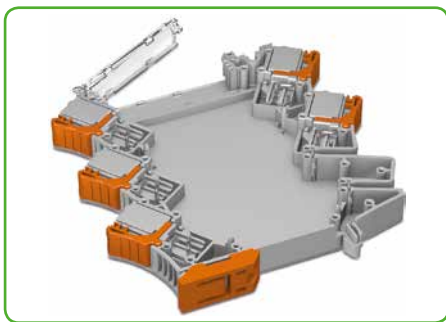

1. Pre-assembled unit

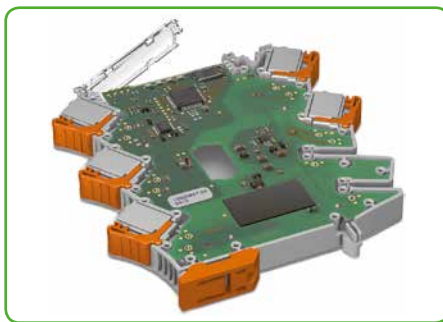



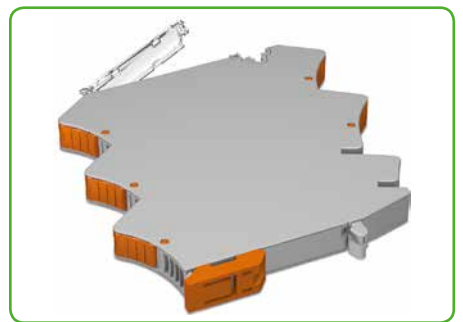



2. Inserting and soldering the PCB.



3. Snapping on side wall.

Housing configuration

Housing width: 12.5 mm	 2857-101	 2857-102	 2857-103	-
Housing width: 22.5 mm	 2857-121	 2857-122	 2857-123	 2857-124
Connection levels	2-2	3-2	3-3	1-1
Jumper slots	2-2	0-2	0-0	2-2

Mixed configuration (fixed/removable/empty slot) upon request

Example of connection level and jumper slot assignment:

Connection levels	3-2
Jumper slots	0-2

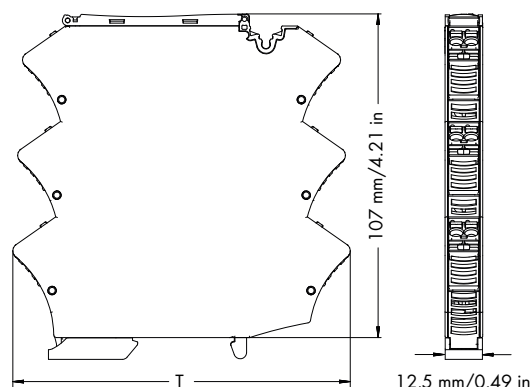
**Features:**

- picoMAX® female connectors, with coding keys, 2-pole
- Pre-assembled unit
- Flexible conductor termination
- Customization of connection levels
- Various marking options available
- Sealable, transparent cover
- Commoning option via 859-402 jumpers

Description	Item No.	Pack. Unit
Modular empty housing, for DIN 35 rail		
Housing width: 12.5 mm		
2-2 connection levels, 2-2 jumper slots	2857-101	10
3-2 connection levels, 0-2 jumper slots	2857-102	10
3-3 connection levels, 0-0 jumper slots	2857-103	10

Technical Data: Female Connector with picoMAX® 5.0 Conductor Termination			
Technical Data:			
Pin spacing	5 mm / 0.197 in		
Ratings per	IEC/EN 60664-1		
Overvoltage category EN	III	III	II
Pollution degree	3	2	2
Rated voltage EN	250 V	320 V	630 V
Rated surge voltage	4 kV	4 kV	4 kV
Nominal current	16 A	16 A	16 A
Approvals per	UL/CSA		
Use group UL 1059	B	C	D
Rated voltage	300 V	-	300 V
Nominal current UL	15 A	-	10 A
Conductor Data:			
Wire connection	CAGE CLAMP® S		
Solid sizes	0.2 ... 2.5 mm ² / AWG 24 ... 12		
Fine-stranded wires	0.2 ... 2.5 mm ² / AWG 24 ... 12		
Fine-stranded wires with insulated ferrule	0.2 ... 1.5 mm ² / AWG 24 ... 16		
Fine-stranded wires with uninsulated ferrule	0.2 ... 2.5 mm ² / AWG 24 ... 14		
Strip length	9 ... 10 mm / 0.35 ... 0.39 in		
Material Data:			
Clamping spring material	Chrome nickel spring steel (CrNi)		
Contact material	Electrolytic copper (Ecu)		
Contact plating	Tin-plated		
Insulating material	Polyphthalamide glass fiber (PPA-GF)		
Flammability rating	V0		
For additional technical data, see WAGO's picoMAX® catalog.			

Technical Data: Empty Housing	
Material Data:	
Housing material	PC
Flammability rating	V0
Environmental Requirements:	
Ambient operating temperature	-40 °C ... +70 °C
Storage temperature	-40 °C ... +85 °C
Dimensions:	
Dimensions (mm) W x H x L	12.5 x 107 x 108 (2857-101)
	12.5 x 107 x 110 (2857-102)
	12.5 x 107 x 112 (2857-103)
	Height from upper-edge of DIN 35 rail
Technical Data:	
Power loss	2 W
Accessories	Coding key carrier: 2092-1610
	Jumpers: 859-402
	Marker strips, WMB and
	WMB Inline: see Full Line Catalog
	INTERFACE ELECTRONIC 2012/2013,
	pages 402 and 408

Modular Empty Housing

Housing width: 22.5 mm

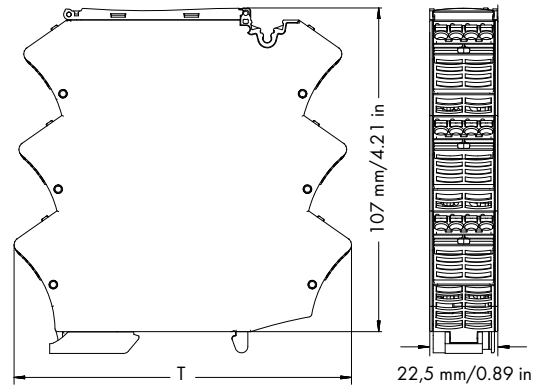

Features:

- picoMAX® female connectors, with coding keys, 4-pole
- Pre-assembled unit
- Flexible conductor termination
- Customization of connection levels
- Various marking options available
- Sealable, transparent cover
- Commoning option via 859-402 jumpers

Description	Item No.	Pack. Unit
Modular empty housing, for DIN 35 rail		
Housing width: 22.5 mm		
2-2 connection levels, 2-2 jumper slots	2857-121	5
3-2 connection levels, 0-2 jumper slots	2857-122	5
3-3 connection levels, 0-0 jumper slots	2857-123	5
1-1 connection levels, 2-2 jumper slots	2857-124	5

Technical Data: Empty Housing	
Material Data:	
Housing material	PC
Flammability rating	V0
Environmental Requirements:	
Ambient operating temperature	-40 °C ... +70 °C
Storage temperature	-40 °C ... +85 °C
Dimensions:	
Dimensions (mm) W x H x L	22.5 x 107 x 108 (2857-121)
	22.5 x 107 x 110 (2857-122)
	22.5 x 107 x 112 (2857-123)
	22.5 x 107 x 105 (2857-124)
	Height from upper-edge of DIN 35 rail
Technical Data:	
Power loss	3 W
Accessories	Coding key carrier: 2092-1610
	Jumpers: 859-402
	Marker strips, WMB and
	WMB Inline: see Full Line Catalog
	INTERFACE ELECTRONIC 2012/2013,
	pages 402 and 408

Technical Data: Female Connector with picoMAX® 5.0 Conductor Termination			
Technical Data:			
Pin spacing	5 mm / 0.197 in		
Ratings per	IEC/EN 60664-1		
Overvoltage category EN	III	III	II
Pollution degree	3	2	2
Rated voltage EN	250 V	320	630 V
Rated surge voltage	4 kV /	4 kV	4 kV
Nominal current	16 A	16 A	16 A
Approvals per	UL/CSA		
Use group UL 1059	B	C	D
Rated voltage	300 V	-	300 V
Nominal current UL	15 A	-	10 A
Conductor Data:			
Wire connection	CAGE CLAMP® S		
Solid sizes	0.2 ... 2.5 mm ² / AWG 24 ... 12		
Fine-stranded wires	0.2 ... 2.5 mm ² / AWG 24 ... 12		
Fine-stranded wires with insulated ferrule	0.2 ... 1.5 mm ² / AWG 24 ... 16		
Fine-stranded wires with uninsulated ferrule	0.2 ... 2.5 mm ² / AWG 24 ... 14		
Strip length	9 ... 10 mm / 0.35 ... 0.39 in		
Material Data:			
Clamping spring material	Chrome nickel spring steel (CrNi)		
Contact material	Electrolytic copper (Ecu)		
Contact plating	Tin-plated		
Insulating material	Polyphthalamide glass fiber (PPA-GF)		
Flammability rating	V0		
For additional technical data, see WAGO's picoMAX® catalog.			

Stripboards, 2857 Series

for Empty Housings

Stripboard
2-2 connection levels
2-2 jumper slots

Stripboard
3-2 connection levels
0-2 jumper slots

Stripboard
3-3 connection levels
0-0 jumper slots

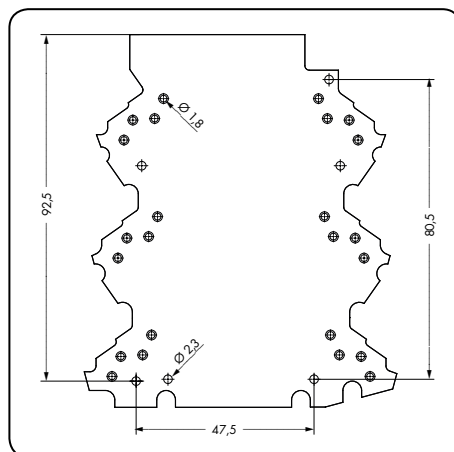
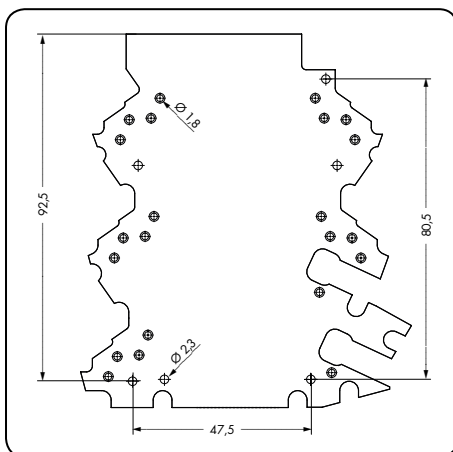
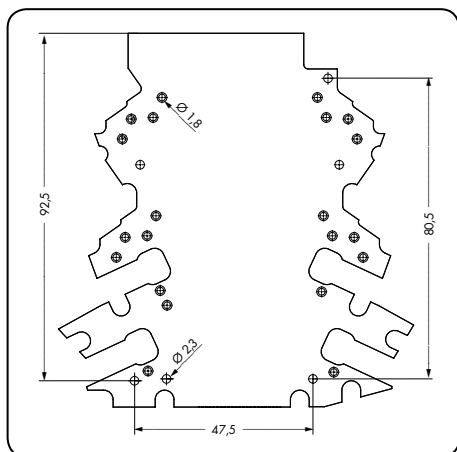
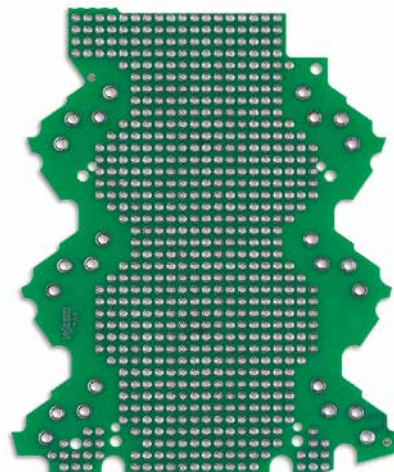
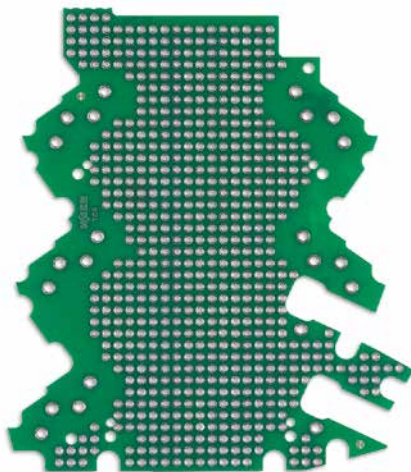
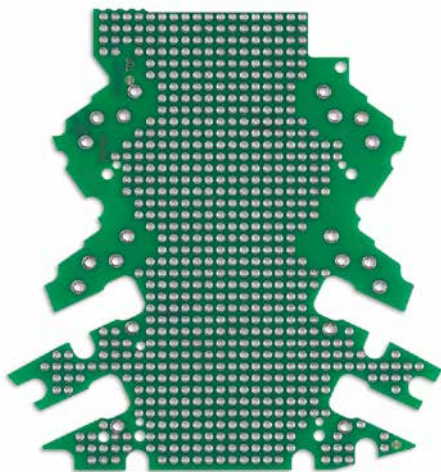

Item No.	Pack. Unit	Item No.	Pack. Unit	Item No.	Pack. Unit
Stripboard, for installation in 12.5mm and 22.5mm empty housings		Stripboard, for installation in 12.5mm and 22.5mm empty housings		Stripboard, for installation in 12.5mm and 22.5mm empty housings	
2857-191/3140-000	5 (5 x 1)	2857-192/3140-000	5 (5 x 1)	2857-193/3140-000	5 (5 x 1)

Stripboards, 2857 Series

for Empty Housings

<p>Stripboard 1-1 connection levels 2-2 jumper slots</p>		
---	--	--

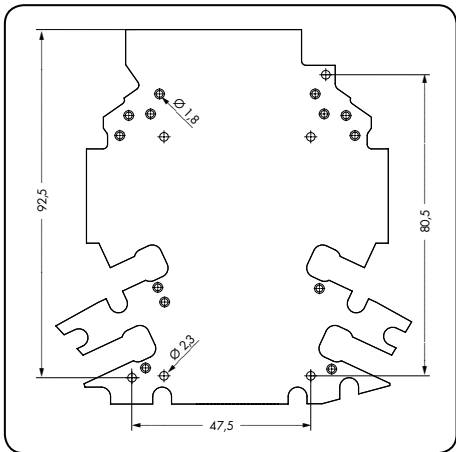
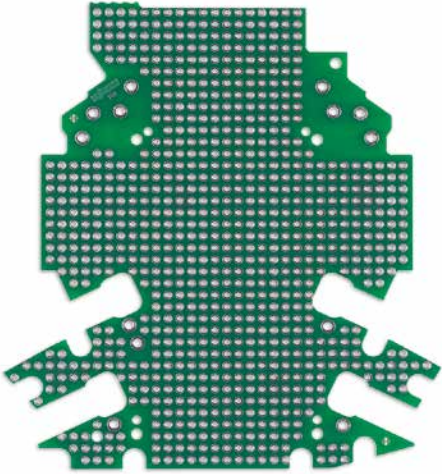

Item No.	Pack. Unit
<p>Stripboard, for installation in 12.5mm and 22.5mm empty housings</p>	
<p>2857-194/3140-000</p>	<p>5 (5 x 1)</p>

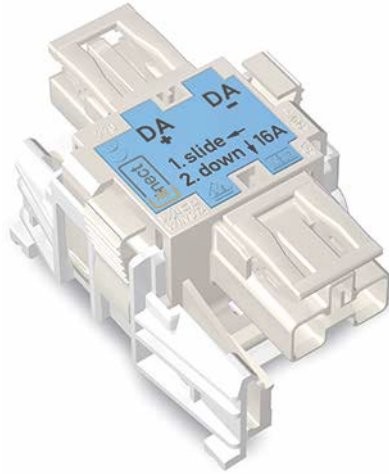
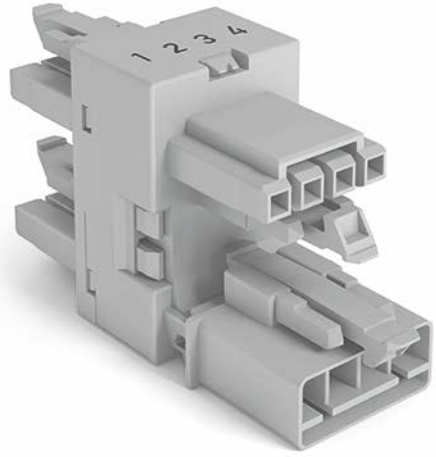

Contents

Volume 5

	WINSTA® MINI PCB Connectors, 2-Pole	890 Series	102
	PCB Connectors, 3-Pole	890 Series	104
	PCB Connectors, 4-Pole	890 Series	106
	PCB Connectors, 5-Pole	890 Series	108
	WINSTA® MINI special PCB Connectors, 2-Pole	890 Series	110
	PCB Connectors, 3-Pole	890 Series	112
	PCB Connectors, 4-Pole	890 Series	114
	PCB Connectors, 5-Pole	890 Series	120
	WINSTA® MINI special Distribution Connectors, 4-Pole	890 Series	116
	WINSTA® MINI special Plugs and Sockets, 5-Pole	890 Series	118
	Snap-In Plugs and Sockets, 5-Pole	890 Series	119
	WINSTA® MINI Strain Relief Housings, Short, 2-Pole	890 Series	122
	WINSTA® MINI Operating Tools, 2-, 3-, 4- and 5-Pole	890 Series	122 – 123
	WINSTA® MIDI-Linect® Linect® T-Connector, 2-Pole	770 Series	124
	WINSTA® MIDI Mounting Plate, for Distribution Connectors, 2-Pole	770 Series	125
	WINSTA® MIDI Operating Tool, 2- and 3-Pole	770 Series	125

WINSTA® MINI
PCB Connectors, 2-Pole

	250 V/4 kV/3 I_N 16 A 1 Approvals	250 V/4 kV/3 I_N 16 A 1 Approvals
--	---	---



Description	Color	Item No.	Pack. Unit	Color	Item No.	Pack. Unit
PCB connectors, 2 solder pins per pole	Socket, straight			Plug, straight		
	● black	890-802	100	● black	890-812	100
	○ white	890-822	100	○ white	890-832	100
	● blue	890-3102	100	● blue	890-3112	100
Info	Dimensions					

1 Approvals are available online at:
www.wago.com

● black	Coding A	(L N)
○ white	Coding A	(L N)
● blue	Coding I	(+ -)

For coding information, see Full Line Catalog, Volume 5.
Fire load data available upon request.

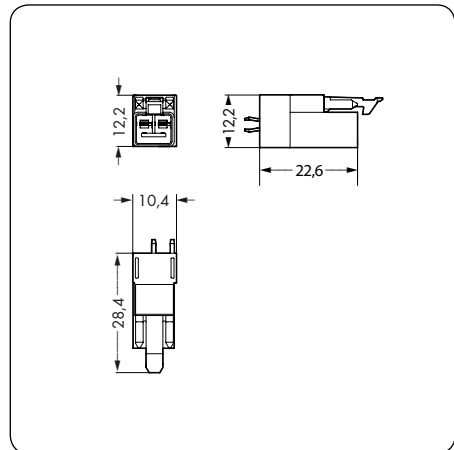
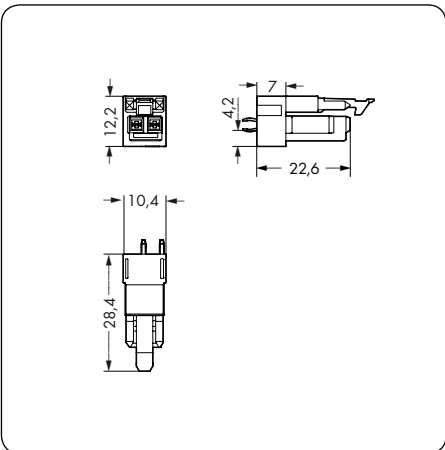

<p>250 V/4 kV/3 I_N 16 A</p> <p>① Approvals</p>	<p>250 V/4 kV/3 I_N 16 A</p> <p>① Approvals</p>
--	--



Color	Item No.	Pack. Unit	Color	Item No.	Pack. Unit
Socket, angled			Plug, angled		
● black	890-802/011-000	100	● black	890-812/011-000	100
○ white	890-822/011-000	100	○ white	890-832/011-000	100
● blue	890-3102/011-000	100	● blue	890-3112/011-000	100

Dimensions	Hole patterns
-------------------	----------------------

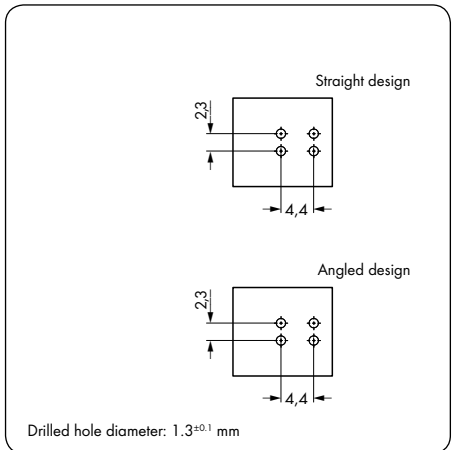
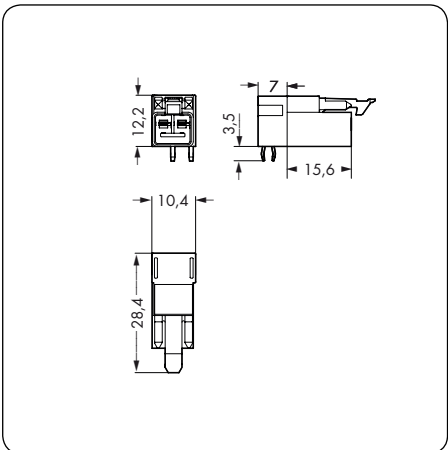
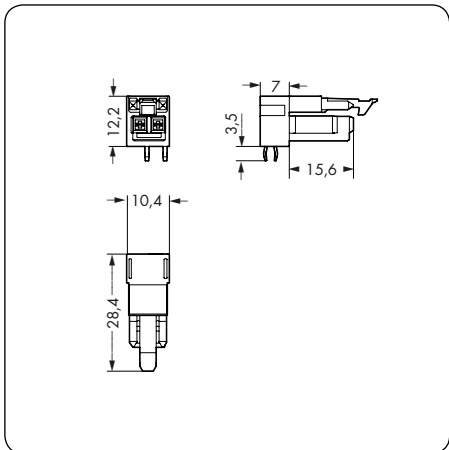

WINSTA® MINI PCB Connectors, 3-Pole

	250 V/4 kV/3 I_N 16 A ② ① Approvals	250 V/4 kV/3 I_N 16 A ② ① Approvals
--	---	---



Description	Color	Item No.	Pack. Unit	Color	Item No.	Pack. Unit
PCB connectors, 2 solder pins per pole	Socket, straight			Plug, straight		
	● black	890-803	100	● black	890-813	100
	○ white	890-823	100	○ white	890-833	100
Info	Dimensions					

① Approvals are available online at:
www.wago.com

② For 3-pole load $I_N = 13$ A!

● black Coding A (L ⊕ N)
○ white Coding A (L ⊕ N)

For coding information, see Full Line Catalog, Volume 5.
Fire load data available upon request.

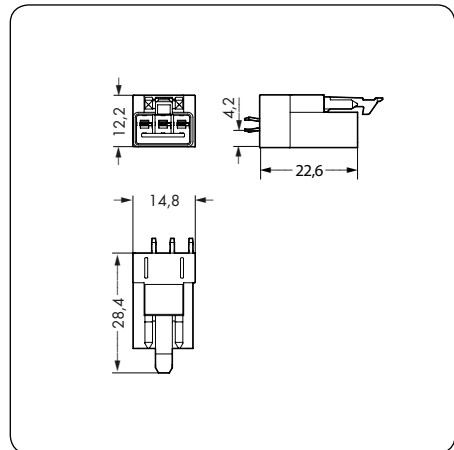
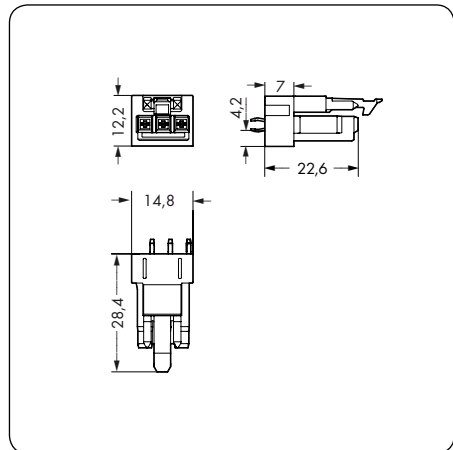

250 V/4 kV/3 I_N 16 A ② ① Approvals	250 V/4 kV/3 I_N 16 A ② ① Approvals
---	---



Color	Item No.	Pack. Unit	Color	Item No.	Pack. Unit
Socket, angled			Plug, angled		
● black	890-803/011-000	100	● black	890-813/011-000	100
○ white	890-823/011-000	100	○ white	890-833/011-000	100
Dimensions			Hole patterns		

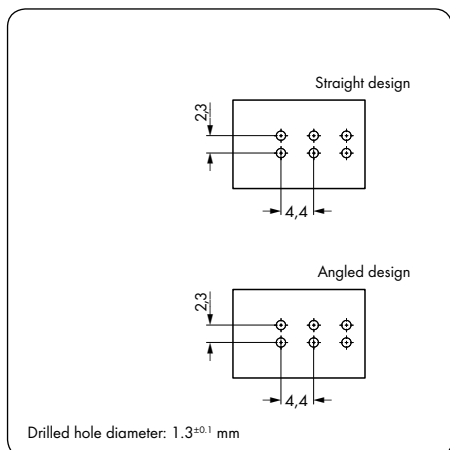
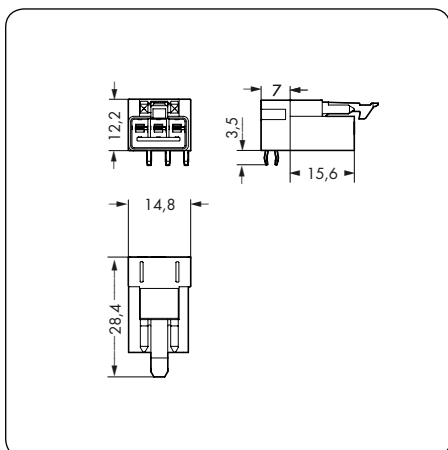
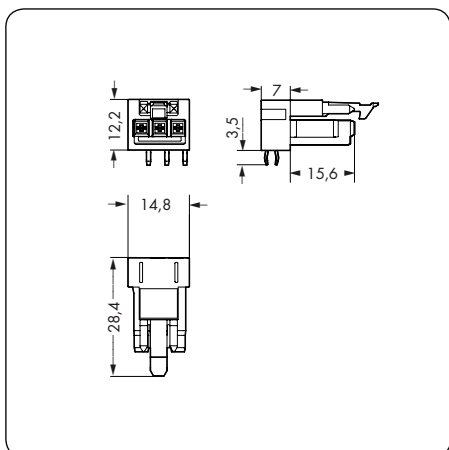

WINSTA® MINI PCB Connectors, 4-Pole

	<p>400 V/6 kV/3 I_N 16 A ②</p> <p>① Approvals</p>	<p>400 V/6 kV/3 I_N 16 A ②</p> <p>① Approvals</p>
--	--	--



Description	Color	Item No.	Pack. Unit	Color	Item No.	Pack. Unit
PCB connectors, 2 solder pins per pole	Socket, straight			Plug, straight		
	● black	890-804	100	● black	890-814	100
	○ white	890-824	100	○ white	890-834	100
Info	Dimensions					

① Approvals are available online at:
www.wago.com

② For 3-pole load $I_N = 13$ A!
For 4-pole load $I_N = 10$ A!

● black Coding A (N ⊕ 2L 1L)

○ white Coding A (N ⊕ 2L 1L)

For coding information, see Full Line Catalog, Volume 5.
Fire load data available upon request.

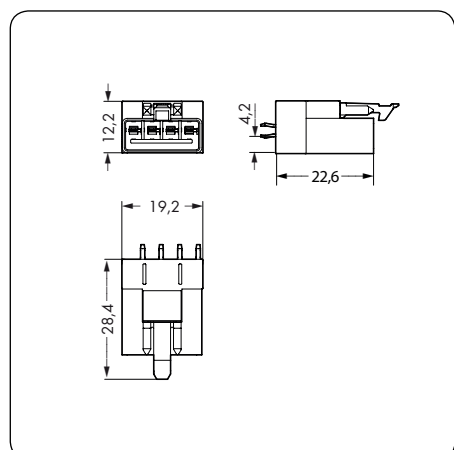
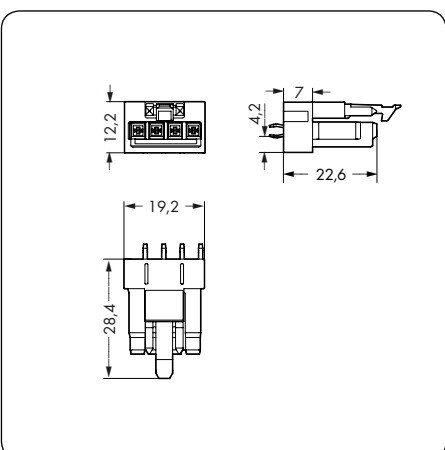

400 V/6 kV/3 I_N 16 A ② ① Approvals	400 V/6 kV/3 I_N 16 A ② ① Approvals
---	---



Color	Item No.	Pack. Unit	Color	Item No.	Pack. Unit
Socket, angled			Plug, angled		
● black	890-804/011-000	100	● black	890-814/011-000	100
○ white	890-824/011-000	100	○ white	890-834/011-000	100
Dimensions			Hole patterns		

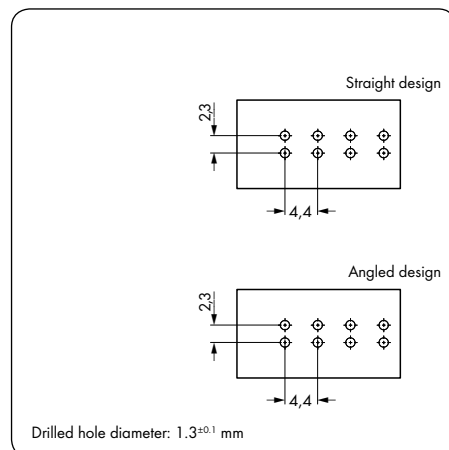
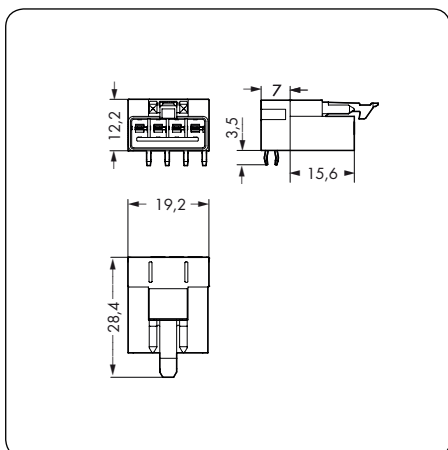
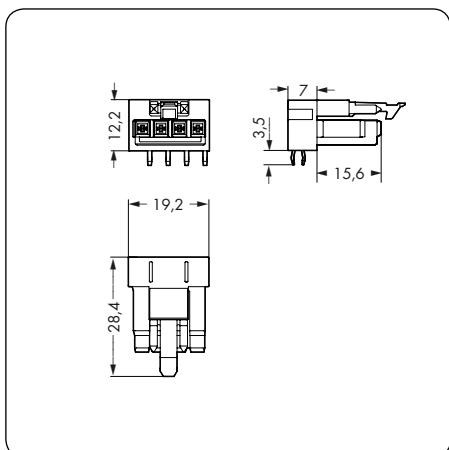

400 V/6 kV/3 I_N 16 A ②	400 V/6 kV/3 I_N 16 A ②
① Approvals	① Approvals



Color	Item No.	Pack. Unit	Color	Item No.	Pack. Unit
Socket, angled			Plug, angled		
● black	890-805/011-000	100	● black	890-815/011-000	100
○ white	890-825/011-000	100	○ white	890-835/011-000	100
● blue	890-3105/011-000	100	● blue	890-3115/011-000	100

Dimensions	Hole patterns
-------------------	----------------------

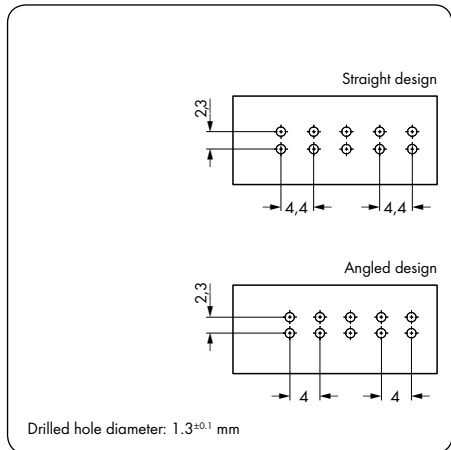
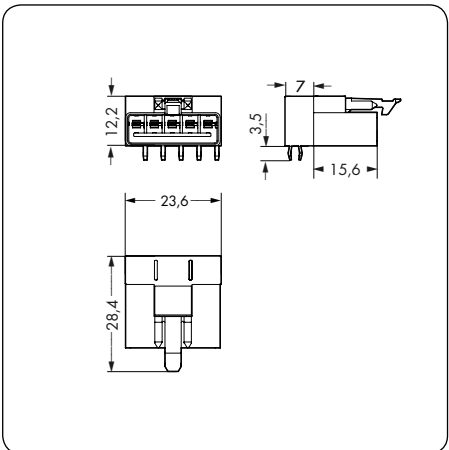
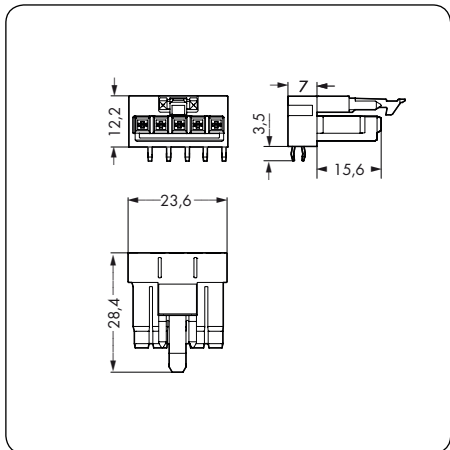

WINSTA® MINI special PCB Connectors, 2-Pole

	250 V/4 kV/3 I_N 16 A ① Approvals	250 V/4 kV/3 I_N 16 A ① Approvals
--	---	---



Description	Color	Item No.	Pack. Unit	Color	Item No.	Pack. Unit
PCB connectors, 2 solder pins per pole	Socket, straight			Plug, straight		
	gray	890-842	100	gray	890-852	100
	light green	890-862	100	light green	890-872	100
	pink	890-882	100	pink	890-892	100
Info	Dimensions					

① Approvals are available online at:
www.wago.com

- gray Coding B (1 2)
- light green Coding B (1 2)
- pink Coding B (1 2)

For coding information, see Full Line Catalog, Volume 5.
 Fire load data available upon request.

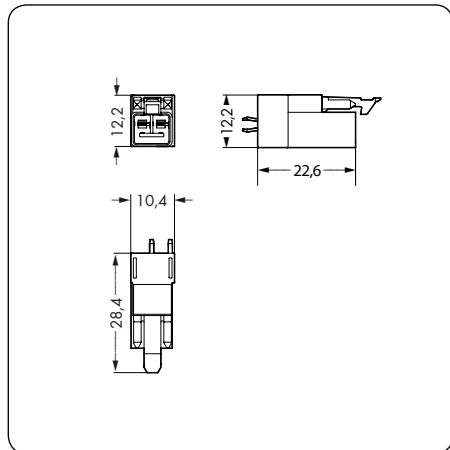
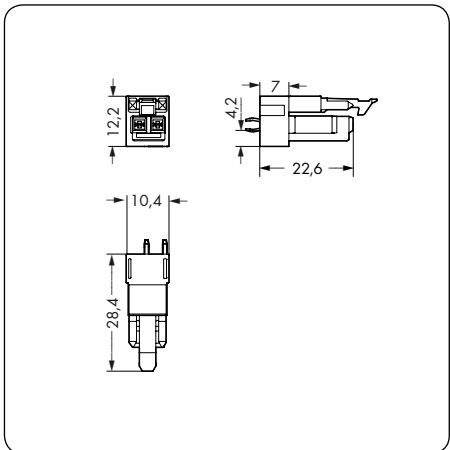

250 V/4 kV/3 I_N 16 A 1 Approvals	250 V/4 kV/3 I_N 16 A 1 Approvals
---	---



Color	Item No.	Pack. Unit	Color	Item No.	Pack. Unit
Socket, angled			Plug, angled		
gray	890-842/011-000	100	gray	890-852/011-000	100
light green	890-862/011-000	100	light green	890-872/011-000	100
pink	890-882/011-000	100	pink	890-892/011-000	100
Dimensions			Hole patterns		

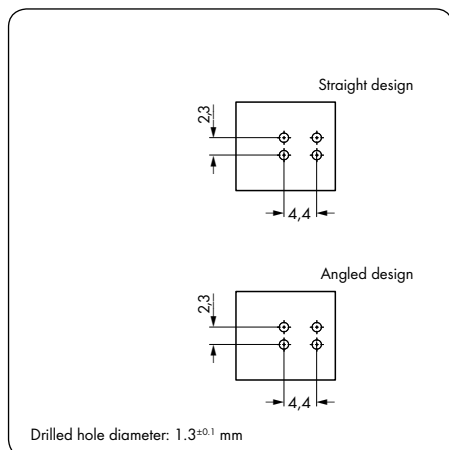
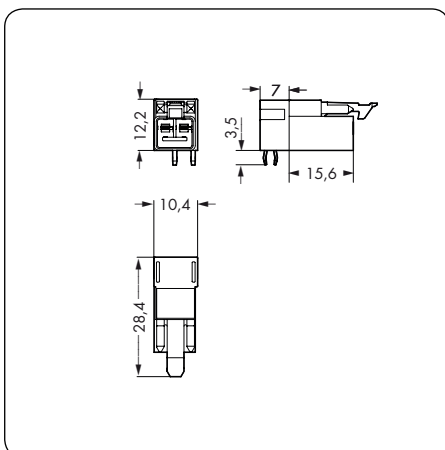
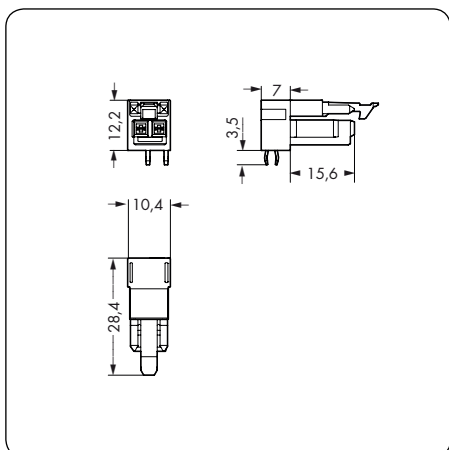

WINSTA® MINI special PCB Connectors, 3-Pole

	250 V/4 kV/3 I_N 16 A ② ① Approvals	250 V/4 kV/3 I_N 16 A ② ① Approvals
--	---	---



Description	Color	Item No.	Pack. Unit	Color	Item No.	Pack. Unit
PCB connectors, 2 solder pins per pole	Socket, straight			Plug, straight		
	gray	890-843	100	gray	890-853	100
	light green	890-863	100	light green	890-873	100
	pink	890-883	100	pink	890-893	100
Info	Dimensions					

① Approvals are available online at:
www.wago.com

② For 3-pole load $I_N = 13 A!$

gray	Coding B	(1 2 3)
light green	Coding B	(1 2 3)
pink	Coding B	(1 2 3)

For coding information, see Full Line Catalog, Volume 5.
Fire load data available upon request.

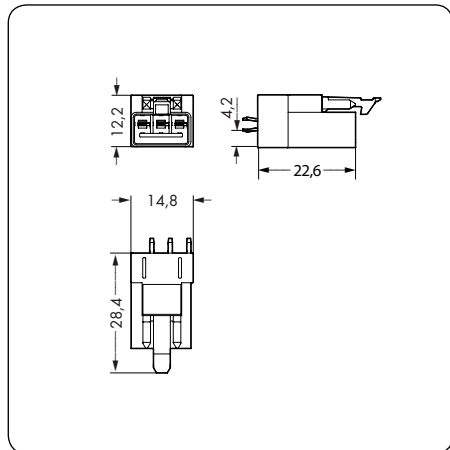
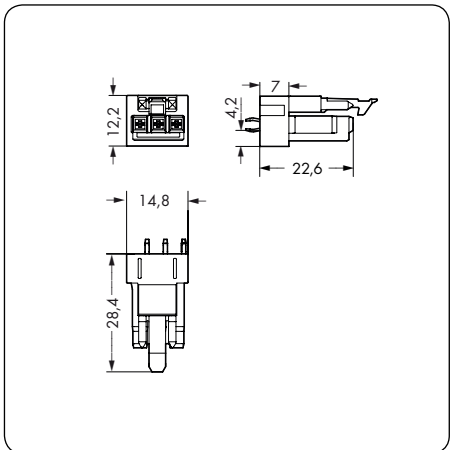

<p>250 V/4 kV/3 I_N 16 A ②</p> <p>① Approvals</p>	<p>250 V/4 kV/3 I_N 16 A ②</p> <p>① Approvals</p>
---	---



Color	Item No.	Pack. Unit	Color	Item No.	Pack. Unit
Socket, angled			Plug, angled		
gray	890-843/011-000	100	gray	890-853/011-000	100
light green	890-863/011-000	100	light green	890-873/011-000	100
pink	890-883/011-000	100	pink	890-893/011-000	100
Dimensions			Hole patterns		

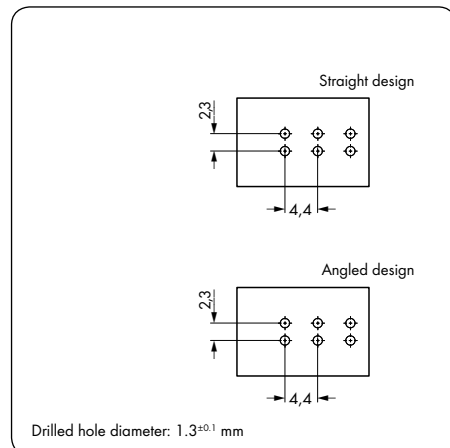
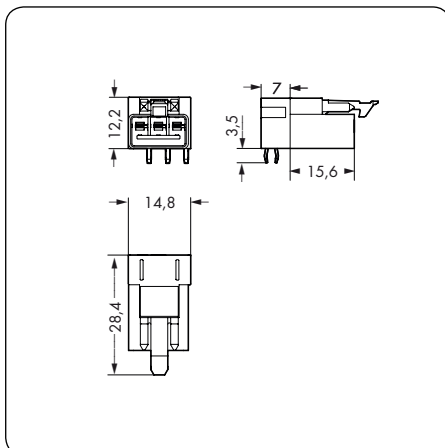
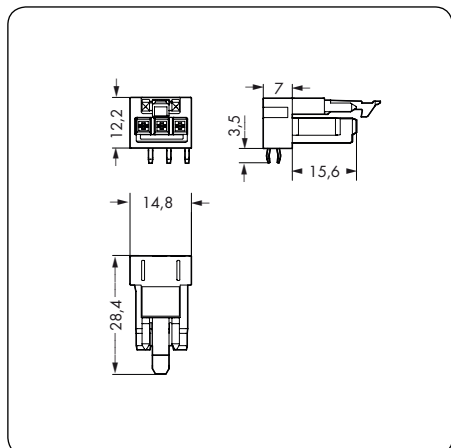

WINSTA® MINI special PCB Connectors, 4-Pole

	<p>400 V/6 kV/3 I_N 16 A ②</p> <p>① Approvals</p>	<p>400 V/6 kV/3 I_N 16 A ②</p> <p>① Approvals</p>
--	---	---



Description	Color	Item No.	Pack. Unit	Color	Item No.	Pack. Unit
PCB connectors, 2 solder pins per pole	Socket, straight			Plug, straight		
	gray	890-844	100	gray	890-854	100
	light green	890-864	100	light green	890-874	100
	pink	890-884	100	pink	890-894	100
Info	Dimensions					

① Approvals are available online at: www.wago.com

② For 3-pole load I_N = 13 A!
For 4-pole load I_N = 10 A!

gray	Coding B	(1 2 3 4)
light green	Coding B	(1 2 3 4)
pink	Coding B	(1 2 3 4)

For coding information, see Full Line Catalog, Volume 5.
Fire load data available upon request.

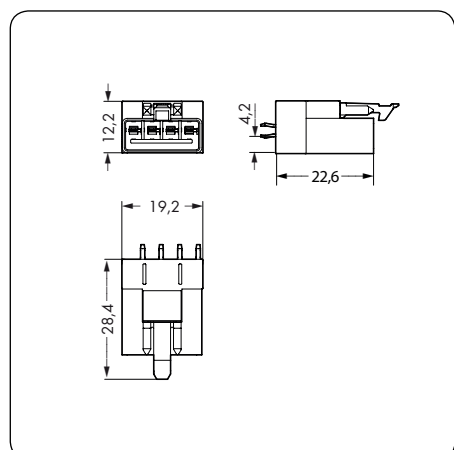
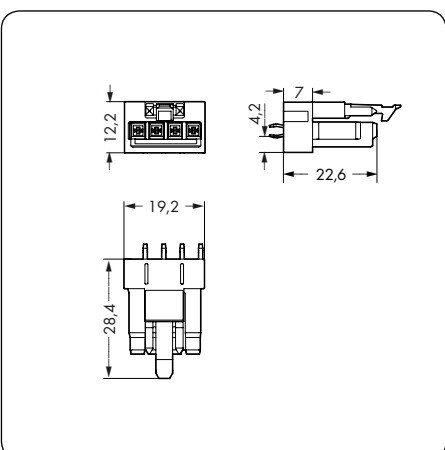

<p>400 V/6 kV/3 I_N 16 A ②</p> <p>① Approvals</p>	<p>400 V/6 kV/3 I_N 16 A ②</p> <p>① Approvals</p>
---	---

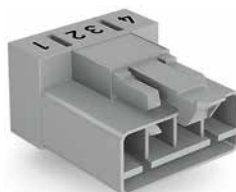
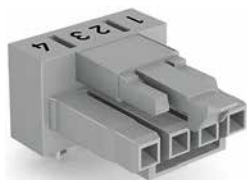

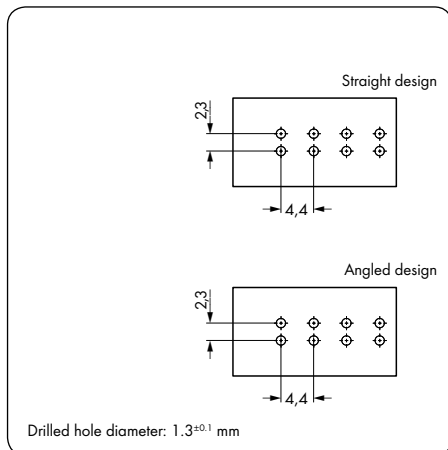
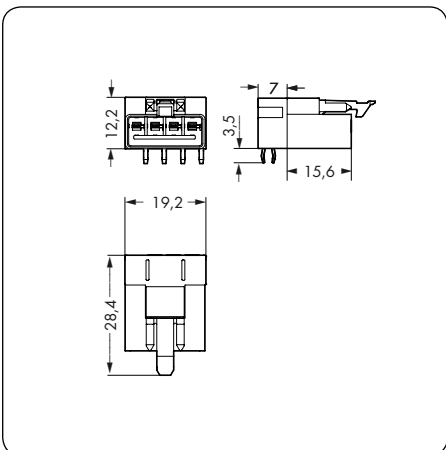
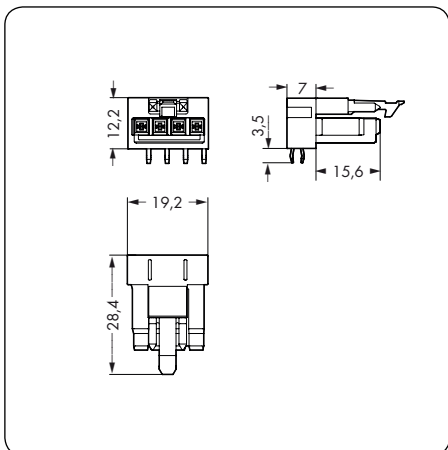

Color	Item No.	Pack. Unit	Color	Item No.	Pack. Unit
Socket, angled			Plug, angled		
gray	890-842/011-000	100	gray	890-852/011-000	100
light green	890-862/011-000	100	light green	890-872/011-000	100
pink	890-882/011-000	100	pink	890-892/011-000	100
Dimensions			Hole patterns		

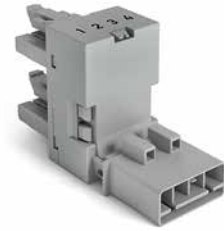

WINSTA® MINI special T- and h-Distribution Connectors, 4-Pole

	<p>400 V/6 kV/3 I_N 16 A ③</p> <p>① Approvals</p>	<p>400 V/6 kV/3 I_N 16 A ③</p> <p>① Approvals</p>
--	--	--



Description	Color	Item No.	Pack. Unit	Color	Item No.	Pack. Unit						
T-distribution connector, h-distribution connector, 4-pole	T-distribution connector, 1 x plug / 2 x socket			h-distribution connector, unidirectional, plug / socket – socket								
	gray	890-1631	50	gray	890-1681	50						
	light green	890-1632	50	light green	890-1682	50						
	pink	890-1633	50	pink	890-1683	50						
	for "flying leads," with 3rd locking lever			for "flying leads," with 3rd locking lever								
	gray	890-1731	50	gray	890-1781	50						
	light green	890-1732	50	light green	890-1782	50						
	pink	890-1733	50	pink	890-1783	50						
For pole marking, see Full Line Catalog, Volume 5!			For pole marking, see Full Line Catalog, Volume 5!									
Item-Specific Accessories												
				Mounting plate , for distribution connectors  <table border="0"> <tr> <td>black</td> <td>890-624</td> <td>50</td> </tr> <tr> <td>white</td> <td>890-674</td> <td>50</td> </tr> </table>			black	890-624	50	white	890-674	50
black	890-624	50										
white	890-674	50										
				Fixing pin , for mounting plates  <table border="0"> <tr> <td>② black</td> <td>890-601</td> <td>250</td> </tr> </table>			② black	890-601	250			
② black	890-601	250										
Info												
Dimensions												

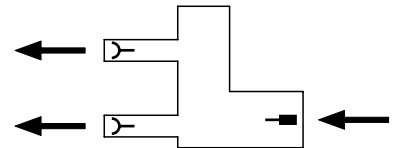
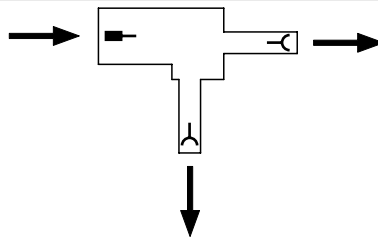

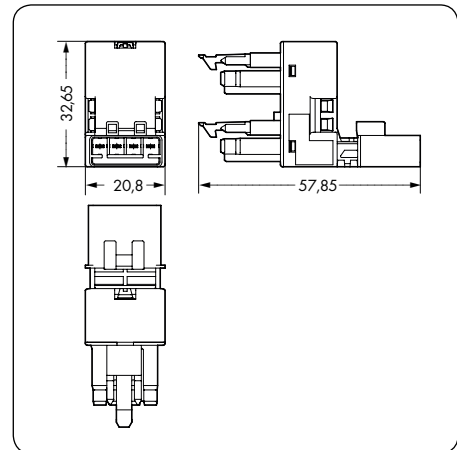
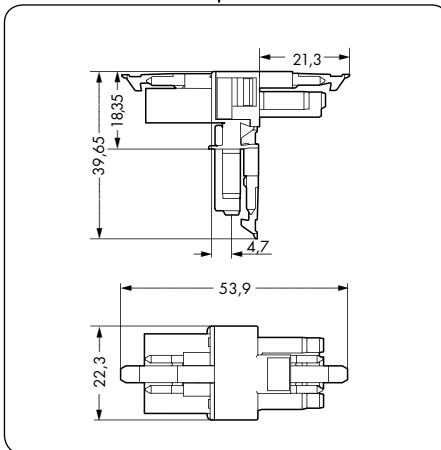

- ① Approvals are available online at: www.wago.com
 - ② 5.0 mm Ø, 0.2–1.2 mm plate thickness
 - ③ For 3-pole load I_N = 13 A!
For 4-pole load I_N = 10 A!
-
- | | | |
|-------------|----------|-----------|
| gray | Coding B | (1 2 3 4) |
| light green | Coding B | (1 2 3 4) |
| pink | Coding B | (1 2 3 4) |
- For coding information, see Full Line Catalog, Volume 5.
Fire load data available upon request.



WINSTA® MINI special Distribution Connectors, 4-Pole

	<p>400 V/6 kV/3 I_N 16 A Ⓢ</p> <p>① Approvals</p>	
--	---	--



Description	Color	Item No.	Pack. Unit
Distribution connectors, 4-pole	Distribution connector, 3-way, 1 x plug / 3 x socket		
	gray	890-1734	50
	light green	890-1735	50
	pink	890-1736	50
For pole marking, see Full Line Catalog, Volume 51			
Item-Specific Accessories			
	Mounting plate, for distribution connectors		
		black 890-624	50
		white 890-674	50
	Fixing pin, for mounting plates		
		② black 890-601	250
Dimensions			

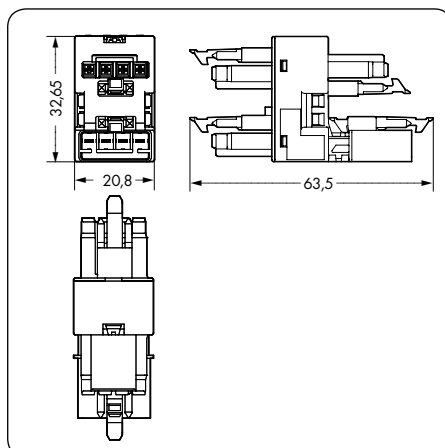
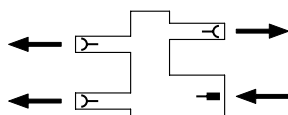

WINSTA® MINI Sockets and Plugs, 5-Pole

<p>0.25–1.5 mm² ① 400 V/6 kV/3 I_N 16 A ③</p> <p>9 mm / 0.35 in</p> <p>② Approvals</p>	<p>22–16 AWG</p> <p>0.25–1.5 mm² ① 400 V/6 kV/3 I_N 16 A ③</p> <p>9 mm / 0.35 in</p> <p>② Approvals</p>
---	--

Notice:

All connectors for fixed installations (snap-in versions for lighting fixtures, devices or all types of PCBs and distribution cabinets) are factory-equipped with locking levers to ensure plugs and sockets are securely locked. Additional locking levers are only required for “flying leads” (plug/socket).



Description	Color	Item No.	Pack. Unit	Color	Item No.	Pack. Unit
Connectors, 5-pole, with CAGE CLAMP® S connection	Socket			Plug		
	gray	890-245	50	gray	890-255	50
	gray	890-245/060-000*	50	gray	890-255/060-000*	50
	gray	890-245/062-000*	50	gray	890-255/062-000*	50
	light green	890-265	50	light green	890-275	50
	light green	890-265/073-000*	50	light green	890-275/073-000*	50
	pink	890-285	50	pink	890-295	50
	pink	890-285/080-000*	50	pink	890-295/080-000*	50
	pink	890-285/082-000*	50	pink	890-295/082-000*	50
	*For pole marking, see Full Line Catalog, Volume 5!			*For pole marking, see Full Line Catalog, Volume 5!		
Accessories, 890 Series						
	Locking lever, for “flying leads,” tool operated			Locking lever, for “flying leads,” tool operated		
		black 890-111 100 (2 x 50)			white 890-131 100 (2 x 50)	
		white 890-131 100 (2 x 50)				
	Mounting carrier, for 2- to 5-pole “flying leads”			Mounting carrier, for 2- to 5-pole “flying leads”		
		black 890-310 100			black 890-310 100	
		white 890-311 100			white 890-311 100	
Info	Dimensions					

① Conductor sizes: 0.25–1.5 mm² “s + f-st”
0.25–1 mm² “stranded”

② Approvals are available online at:
www.wago.com

③ For 3-pole load I_N = 13 A!
For 4- and 5-pole load I_N = 10 A!

Standard printing (without suffix number)

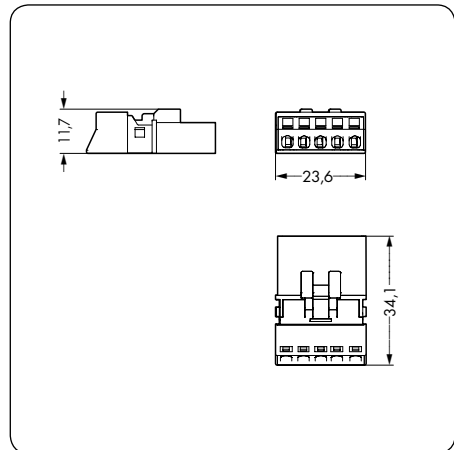
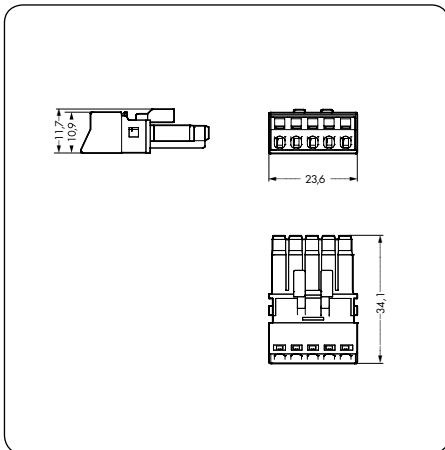

gray	Coding B	(1 2 3 4 5)
light green	Coding B	(1 2 3 4 5)
pink	Coding B	(1 2 3 4 5)

For coding information, see Full Line Catalog, Volume 5.
Fire load data available upon request.



WINSTA® MINI

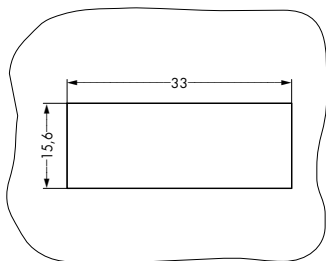

Snap-In Sockets and Plugs, 5-Pole

Cutout dimensions Plate thickness: 0.5–2 mm Cutout tolerance: +0.1 mm	0.25–1.5 mm ² ① 400 V/6 kV/3 I _N 16 A ③	22–16 AWG	0.25–1.5 mm ² ① 400 V/6 kV/3 I _N 16 A ③	22–16 AWG
	 9 mm / 0.35 in ② Approvals		 9 mm / 0.35 in ② Approvals	



Description	Color	Item No.	Pack. Unit	Color	Item No.	Pack. Unit
Snap-in device connectors, 5-pole, with CAGE CLAMP® S connection	Socket			Plug		
	gray	890-745	50	gray	890-755	50
	gray	890-745/060-000*	50	gray	890-755/060-000*	50
	gray	890-745/062-000*	50	gray	890-755/062-000*	50
	light green	890-765	50	light green	890-775	50
	light green	890-765/073-000*	50	light green	890-775/073-000*	50
	pink	890-785	50	pink	890-795	50
	pink	890-785/080-000*	50	pink	890-795/080-000*	50
	pink	890-785/082-000*	50	pink	890-795/082-000*	50
		*For pole marking, see Full Line Catalog, Volume 5!			*For pole marking, see Full Line Catalog, Volume 5!	

Accessories, 890 Series

	Lockout cap, for cutout, 5-pole	Lockout cap, for cutout, 5-pole
	 black 770-643 100 white 770-693 100	 black 770-643 100 white 770-693 100

Dimensions

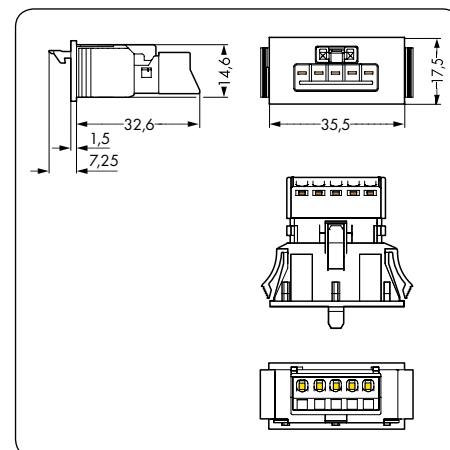
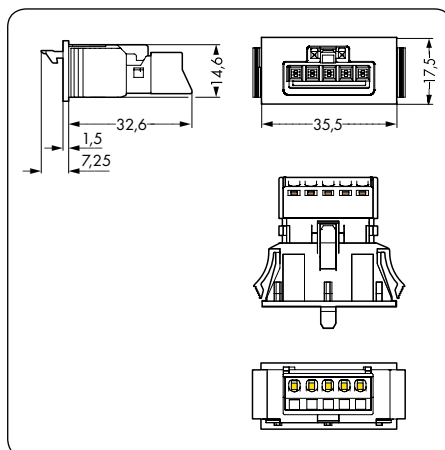

400 V/6 kV/3 I _N 16 A ②	400 V/6 kV/3 I _N 16 A ②
① Approvals	① Approvals

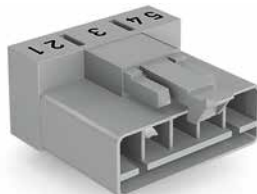
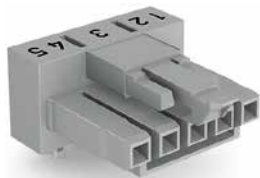

Color	Item No.	Pack. Unit	Color	Item No.	Pack. Unit
Socket, angled			Plug, angled		
gray	890-845/011-000	100	gray	890-855/011-000	100
light green	890-865/011-000	100	light green	890-875/011-000	100
pink	890-885/011-000	100	pink	890-895/011-000	100
Dimensions			Hole patterns		

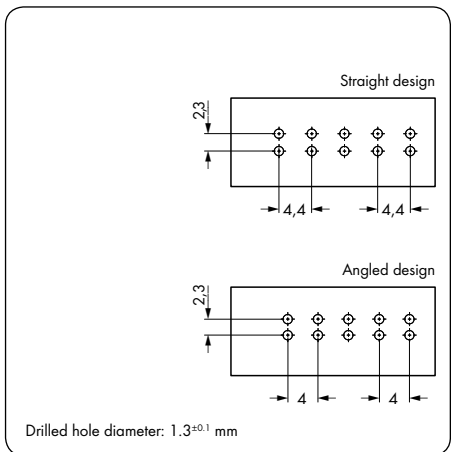
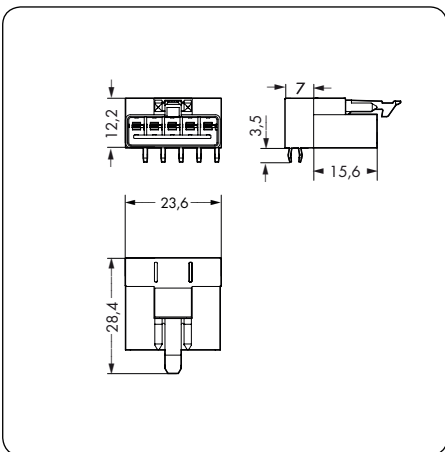
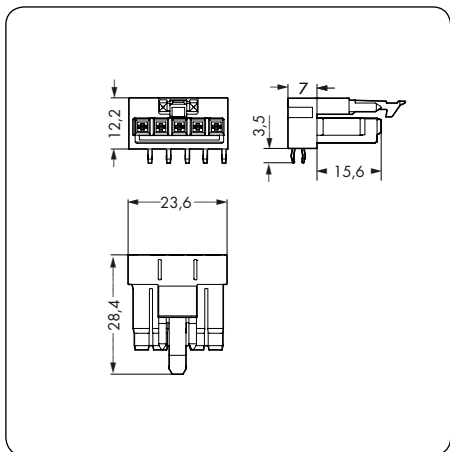

WINSTA® MINI Strain Relief Housings, 2-Pole Operating Tool, 2-Pole

	Snap-on type strain relief housings, short design for space-restricted applications, suitable for: - 2-pole sockets - 2-pole plugs	Operating tool for 2-pole WINSTA® MINI connectors
--	--	---



Description	Color	Item No.	Pack. Unit	Color	Item No.	Pack. Unit
Strain relief housings, operating tool	Strain relief housing, for 3.8-8.2 mm cable diameter			Operating tool, 2-pole, for WINSTA® MINI connectors, 890 Series		
	black	890-502/342-000	50			
	white	890-512/342-000	50	green	890-382	1
Info	Dimensions					

For coding information, see Full Line Catalog, Volume 5.
Fire load data available upon request.

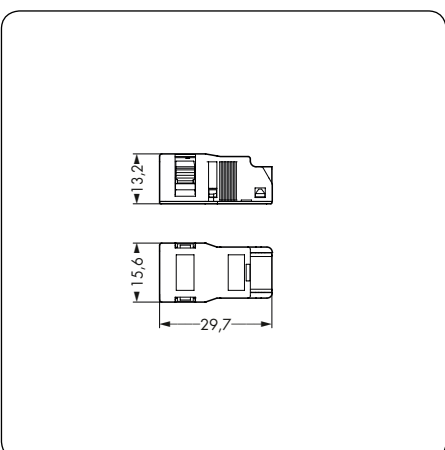

WINSTA® MINI

Operating Tool, 3- and 5-Pole

Operating tool for 3-pole WINSTA® MINI connectors	Operating tool for 4-pole WINSTA® MINI connectors	Operating tool for 5-pole WINSTA® MINI connectors
---	---	---



Color	Item No.	Pack. Unit	Color	Item No.	Pack. Unit	Color	Item No.	Pack. Unit
Operating tool, 3-pole, for WINSTA® MINI connectors, 890 Series			Operating tool, 4-pole, for WINSTA® MINI connectors, 890 Series			Operating tool, 5-pole, for WINSTA® MINI connectors, 890 Series		
green	890-383	1	green	890-384	1	green	890-385	1

WINSTA® MIDI
Linect® T-Connector, 2-Pole

250 V/4 kV/3
I_N 25 A (16 A) ①

② Approvals

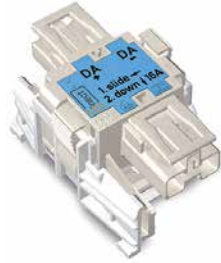

Description	Color	Item No.	Pack. Unit
Linect® T-connector, 2-pole, socket - plug, white housing, blue cover	● blue	770-7102	25
	Suitable for 294-8032 lighting connector		
Item-Specific Accessories			
Lockout cap, for socket, separable, 12-pole	black	770-201	100
	white	770-221	100
Lockout cap, for plug, separable, 5-pole	yellow	770-360	100
Info		Dimensions	

② Approvals are available online at:
www.wago.com

● blue Coding I (DA- DA+)

For coding information, see Full Line Catalog, Volume 5.
Fire load data available upon request.

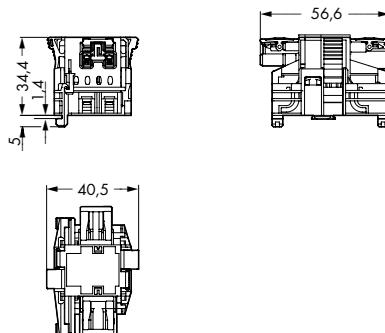

WINSTA® MIDI Mounting Plate, 2-Pole Operating Tool, 2- and 3-Pole

Mounting plate	Operating tool for 2-pole WINSTA® MIDI connectors	Operating tool for 3-pole WINSTA® MIDI connectors
----------------	---	---

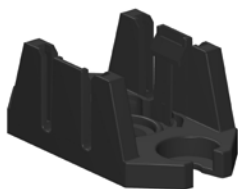

Color	Item No.	Pack. Unit	Color	Item No.	Pack. Unit	Color	Item No.	Pack. Unit
Mounting plate , for 2-pole distribution connectors			Operating tool , 2-pole, for WINSTA® MIDI connectors, 770 Series			Operating tool , 3-pole, for WINSTA® MIDI connectors, 770 Series		
● black	770-1626	25						
○ white	770-1627	25	green	770-382	1	green	770-383	1

Item-Specific Accessories





Fixing pin, for mounting plates				
	② black	890-601 250		
	③ black	770-601 250		

Thermal Transfer Printer

smartPRINTER

126



Description	Item No.	Pack. Unit
smartPRINTER		
includes:		
- Power supply unit and cable		
- USB cable		
- 1 x marking strip roll and WMB Inline markers		
- 2 x rollers		
- 1 x roll holder		
- 1 x ink ribbon		
- smartSCRIPT marking software and driver		
	258-5000	1
Accessories		
Ink ribbon for smartPRINTER		
	258-5005	1
Roller for markingSTRIP		
	258-5006	1
Roller for WMB Inline		
	258-5007	1
Roller for Miniature WSB Inline		
	258-5008	1
Carrying case for smartPRINTER		
light gray, with foam padding for printer		
Dimensions (W x H x D): 50 x 26 x 33 cm		
	258-5015	1

Technical Data	
Printing method	Thermal transfer
Print head	Glass layer, spring-mounted
Print speed	max. 127 mm/s (WAGO recommends 50.8 mm/s)
Print width (max.)	47 mm
Print length (max.)	762 mm
Print resolution	300 dpi (12 pixels/mm)
Transmissive/Reflective sensor	yes, centrally fixed
Operating display	Color TFT LCD with navigation button
Memory	8 MB Flash, 16 MB SDRAM
Interfaces	USB, RS-232, ETHERNET 10/100 Mbps
Operating voltage	100 ... 240 VAC, 50 ... 60 Hz (automatic adjustment)
Dimensions (W x H x D)	135 x 175 x 245 mm
Weight	2,000 g (without printing material)
Operating temperature	5 °C ... 40 °C (41 °F ... 104 °F)
Storage temperature	-20 °C ... 50 °C (-4 °F ... 122 °F)
Safety approvals	CE (EMC)
Ink ribbon	External roll diameter: 40 mm; Internal core diameter: 0.5" (12.7 mm); Max. length: 110 m; Max. width: 58 mm

Markers and Cable Marking

Markers	Cable Marking	Cable Marking
---------	---------------	---------------



Similar to picture

Item No.	Pack. Unit	Item No.	Pack. Unit	Item No.	Pack. Unit
Miniature WSB Inline markers		Marking sleeve		Marking sleeve	
plain		Sleeve length: 12 mm		Sleeve length: 23 mm	
stretchable 5 ... 5.2 mm		500 pcs		Mounting via cable tie	
1,700 markers (5 mm) per roll		for 1.4-5 mm wire diameter		200 pcs	
white	2009-145	transparent	211-812	transparent	211-829
	1		1		1
Spare roller for TP 298+		for 5-11 mm wire diameter		Marker for marking sleeve	
for accommodating the Mini-WSB Inline markers		transparent	211-813	23 x 4 mm	
(for printer 04/2012 and later)			1	2,500 pieces per roll	
258-183	1	Marker for marking sleeve		white	211-821
		12 x 4 mm			1
		2,500 pieces per roll			
		white	211-811		
			1		
		Marking sleeve			
		Sleeve length: 23 mm			
		500 pcs			
		for 1.4-5 mm wire diameter			
		transparent	211-823		
			1		
		200 pcs			
		for 5-11 mm wire diameter			
		transparent	211-824		
			1		
		Marker for marking sleeve			
		23 x 4 mm			
		2,500 pieces per roll			
		white	211-821		
			1		

Cable Marking and Labels

Cable Marking	Cable Marking	Label Rolls and Type Plates
---------------	---------------	-----------------------------



Similar to picture



Similar to picture

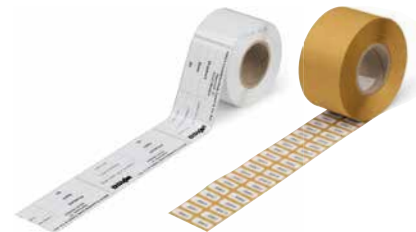

Item No.	Pack. Unit	Item No.	Pack. Unit	Item No.	Pack. Unit
Cable tie marker		Wire marker for thread-on mounting		Label roll	
500 pieces per roll		1,000 pieces per roll		Polyester, self-adhesive	
25 x 20 mm		0.75 ... 1.5 mm ²		3,000 labels per roll	
25 x 10 mm write-on surface		white		6 x 15 mm	
white	211-835		1	white	210-805
				yellow	210-805/000-002
800 pieces per roll		2.5 ... 6 mm ²		9 x 15 mm	
Inner wrap (write-on surface on the inner side)		white		white	
117.5 x 15 mm		211-862		210-806	
100 x 15 mm write-on surface		1		yellow	
white	211-836		1	210-806/000-002	
				8 x 20 mm	
				white	
				210-807	
				yellow	
				210-807/000-002	
Self-laminating labels (no illustration)				9.5 x 25 mm	
1,000 pieces per roll				white	
9 x 18 mm write-on surface				210-808	
white	211-855		1	5 x 35 mm	
				white	
				210-810	
				Type plates	
Self-laminating labels (no illustration)				Polyester	
1,000 pieces per roll				500 markers per roll	
15 x 22 mm write-on surface				70 x 33 mm	
white	211-856		1	white	210-801
				silver	210-802
				99 x 44 mm	
				white	
				210-803	
				silver	
				210-804	
				Label roll	
				Fabric, self-adhesive	
				3,000 labels per roll	
				7 x 20 mm	
				white	210-811
				yellow	210-811/000-002

Lables and Push-Button Markers

Continuous Labels	Push-Button Markers	Push-Button Markers
--------------------------	----------------------------	----------------------------



Item No.	Pack. Unit	Item No.	Pack. Unit	Item No.	Pack. Unit
Continuous labels		Push-button markers		Push-button markers	
Polyester, self-adhesive		semi-permanent adhesive		permanent adhesive	
9 lengths at 25 m		1000 markers per roll		1000 markers per roll	
Width: 2.3 mm		26.5 x 18 mm		27 x 12.5 mm	
white	210-831	1	silver	210-850	1
Width: 3 mm		Plastic cover		Plastic cover	
white		100 covers		100 covers	
210-832		26.5 x 18 mm		27 x 12.5 mm	
5 lengths at 25 m		transparent		transparent	
Width: 5 mm		210-851		210-863	
white		1		1	
210-834		Push-button markers		Push-button markers	
Width: 6 mm		semi-permanent adhesive		permanent adhesive	
white		1000 markers per roll		350 markers per roll	
210-833		27.5 x 17.5 mm		27 x 19 mm	
1		silver		silver	
		210-856		210-852	
		1		1	
		Plastic cover		Push-button markers	
		100 covers		permanent adhesive	
		27.5 x 17.5 mm		350 markers per roll	
		transparent		27 x 18 mm	
		210-857		silver	
		1		210-855	
		1		1	
		Push-button markers		Universal push-button frame	
		permanent adhesive		for push-button markers 210-852 and 210-855	
		1000 markers per roll		100 pcs per bag	
		22 x 22 mm		27 x 19 mm	
		silver		black	
		210-858		210-853	
		1		1	
		Plastic cover		Label roll DD (device designation)	
		100 covers		Polyester	
		22 x 22 mm		500 labels per roll	
		transparent		28 x 28 mm	
		210-859		175 µm thick	
		1		silver	
		1		210-854	
		1		1	
		Push-button markers			
		permanent adhesive			
		1000 markers per roll			
		27 x 27 mm			
		silver			
		210-860			
		1			
		Plastic cover			
		100 covers			
		27 x 27 mm			
		transparent			
		210-861			
		1			

Test and Measurement Tools

Clamp Meter
Clamp-Multi-Tester



Item No.	Pack. Unit		
Clamp-Multi-Tester,			
digital clamp meter			
- DC and AC current up to 600 A			
- True RMS and min./max. value measurement			
- DC and AC voltage up to 600 V			
- Manual or automatic selection of measurement range			
- Resistance up to 60 MΩ			
- Capacitance measurement			
- Acoustical continuity test			
- Diode test			
- Data hold function			
- Large LCD with backlight			
- LED measuring point lighting			
- CAT III 600 V overvoltage protection			
- IEC/EN 61010-1 (DIN VDE 0411)			
- Including batteries, measurement leads and carrying bag			
206-816	1		

Application Notes



Voltage testing in switchgear cabinet



Current measurement in switchgear cabinet

Item Number Index

Item No.	Page	Item No.	Page	Item No.	Page	Item No.	Page
206 Series		231 Series		256 Series		769 Series	
206-816	130	231-332/001-000/105-604	91	256-866	87	769-435	38
206-859	76	231-333/001-000/105-604	91	256-867	87		
206-860	76					769-632/007-000	38
206-861	76	231-532/001-000/105-604	91	258 Series			
		231-532/001-000/105-604/997-405	91	258-183	127	769-645/007-000	38
		231-533/001-000/105-604	91				
		231-533/001-000/105-604/997-405	91	258-5000	126		
210 Series		249 Series		258-5005	126	770 Series	
210-118	50	249-116	35	258-5006	126	770-201	124
210-136	19	249-117	35	258-5007	126	770-221	124
210-137	19	249-197	50	258-5008	126		
210-198	50			258-5015	126		
						770-360	124
210-254	28					770-382	125
				280 Series		770-383	125
210-801	128	250 Series		280-394	55		
210-802	128	250-302	85	280-395	55	770-601	125
210-803	128					770-643	121
210-804	128	250-324	85			770-693	121
210-805	128			282 Series			
210-805/000-002	128			282-432	28	770-1626	125
210-806	128	256 Series		282-432/100-000	28	770-1627	125
210-806/000-002	128	256-100	87	282-433	28		
210-807	128			282-433/100-000	28	770-7102	124
210-807/000-002	128	256-200	87	282-434	28		
210-808	128			282-434/100-000	28		
210-810	128	256-300	87	282-435	28	790 Series	
210-811	128			282-435/011-000	28	790-302	46
210-811/000-002	128	256-400	87	282-436	28	790-312	46
210-831	129			282-436/301-000	28		
210-832	129	256-402/334-000	88	282-437	28		
210-833	129			282-437/011-000	28	793 Series	
210-834	129	256-410/334-000	88	282-437/012-000	28	793-501	28
210-850	129			282-438	28	793-501/000-002	32
210-851	129	256-412/334-000	88	282-438/300-000	28	793-501/000-005	32
210-852	129	256-416/334-000	88	282-438/301-000	28	793-501/000-006	32
210-853	129	256-424/334-000	88	282-439	28	793-501/000-007	32
210-854	129	256-436/334-000	88	282-439/011-000	28	793-501/000-012	32
210-855	129	256-448/334-000	88	282-440	28	793-501/000-017	32
210-856	129	256-461	87			793-501/000-023	32
210-857	129			282-881	28	793-501/000-024	32
210-858	129	256-500	87				
210-859	129			282-888	28	793-3501	4
210-860	129	256-502/334-000	88				
210-861	129			283 Series		793-4501	5
210-862	129	256-510/334-000	88	283-407	47	793-4501/000-002	5
210-863	129					793-4501/000-005	5
		256-512/334-000	88	285 Series		793-4501/000-006	5
		256-516/334-000	88	285-172	50	793-4501/000-007	5
211 Series		256-524/334-000	88			793-4501/000-012	5
211-811	127	256-561	87	285-442	35	793-4501/000-017	5
211-812	127					793-4501/000-023	5
211-813	127	256-600	87			793-4501/000-024	5
211-821	127			285-1171	50	793-5501	7
211-823	127	256-602/334-000	88	285-1177	50	793-5501/000-002	7
211-824	127			285-1178	50	793-5501/000-005	7
211-829	127	256-610/334-000	88	285-1184	50	793-5501/000-006	7
211-835	128			285-1185	50	793-5501/000-007	7
211-836	128	256-612/334-000	88	285-1187	50	793-5501/000-012	7
211-855	128	256-616/334-000	88	285-1189	50	793-5501/000-017	7
211-856	128	256-624/334-000	88			793-5501/000-023	7
211-857	128	256-661	87	294 Series		793-5501/000-024	7
211-861	128			294-364	55		
211-862	128	256-700	87	294-384	55	794 Series	
211-863	128					794-5553/000-002	29
		256-800	87			794-5554/000-006	29
215 Series		256-840	87				
215-111	4	256-842	87	294-8032	55		
		256-843	87			805 Series	
		256-844	87			805-152	83
216 Series		256-846	87	734 Series			
216-545	35	256-847	87	734-326	36	805-174	83
216-546	35	256-850	87	734-327	36		
216-547	35	256-852	87	734-328	36	805-302/200-604	81
		256-853	87	734-329	36		
		256-854	87	734-430	44	805-308/200-604	81
221 Series		256-856	87	734-431	44		
221-412	53	256-857	87			805-302/200-604/997-404	81
221-413	53	256-860	87	769 Series			
221-415	53	256-862	87	769-102	38	805-308/200-604/997-406	81
		256-863	87				
		256-864	87	769-102/021-000	38		

Item No.	Page	Item No.	Page	Item No.	Page	Item No.	Page
805 Series		890 Series		890 Series		2001 Series	
805-352	83	890-745/060-000	119	890-882/011-000	111	2001-433	5
		890-745/062-000	119	890-883	112		
805-374	83	890-755	119	890-883/011-000	113	2001-440	5
		890-755/060-000	119	890-884	114		
		890-755/062-000	119	890-884/011-000	115		
		890-765	119	890-885	120		
811 Series		890-765/073-000	119	890-885/011-000	121	2002 Series	
811-310	34	890-775	119	890-892	110	2002-115	7
811-311	34	890-775/073-000	119	890-892/011-000	111	2002-121	7
811-314	34	890-785	119	890-893	112	2002-171	7
811-316	34	890-785/080-000	119	890-893/011-000	113	2002-172	7
811-317	34	890-785/082-000	119	890-894	114		
811-320	34	890-795	119	890-894/011-000	115	2002-400	11
811-321	34	890-795/080-000	119	890-895	120		
811-330	34	890-795/082-000	119	890-895/011-000	121	2002-410	7
811-331	34						
						2002-433	7
811-410	34	890-802	102	890-1631	116		
811-411	34	890-802/011-000	103	890-1632	116	2002-440	7
811-414	34	890-803	104	890-1633	116		
811-420	34	890-803/011-000	105	890-1681	116		
811-421	34	890-804	106	890-1682	116	2002-472	9
811-430	34	890-804/011-000	107	890-1683	116	2002-473	9
811-431	34	890-805	108			2002-473/011-000	20
		890-805/011-000	109	890-1731	116	2002-474	9
811-471	35	890-812	102	890-1732	116	2002-475	9
		890-812/011-000	103	890-1733	116	2002-475/011-000	20
811-482	35	890-813	104	890-1734	117	2002-476	9
		890-813/011-000	105	890-1735	117	2002-477	9
811-612	35	890-814	106	890-1736	117	2002-477/011-000	20
		890-814/011-000	107	890-1781	116	2002-478	9
		890-815	108	890-1782	116	2002-479	9
		890-815/011-000	109	890-1783	116	2002-479/011-000	20
831 Series		890-822	102			2002-480	9
831-503	92	890-822/011-000	103	890-3102	102	2002-481	9
831-505	92	890-823	104	890-3102/011-000	103	2002-481/011-000	20
831-506	92	890-823/011-000	105	890-3105	108	2002-482	9
		890-824	106	890-3105/011-000	109	2002-492	7
859 Series		890-824/011-000	107	890-3112	102	2002-492/000-012	7
859-500	40	890-825	108	890-3112/011-000	103		
		890-825/011-000	109	890-3115	108	2002-511	20
		890-832	102	890-3115/011-000	109	2002-541	20
		890-832/011-000	103			2002-549	20
887 Series		890-833	104	2000 Series			
887-910	54	890-833/011-000	105	2000-115	4	2002-611	20
887-911	54	890-834	106	2000-121	4	2002-800/1000-410	9
		890-834/011-000	107				
		890-835	108	2000-402	4	2002-991	22
890 Series		890-835/011-000	109			2002-992	22
890-111	118			2000-410	4		
890-131	118	890-842	110			2002-1091	19
		890-842/011-000	111	2000-402/000-005	14	2002-1092	19
890-245	118	890-843	112				
890-245/060-000	118	890-843/011-000	113	2000-410/000-005	14	2002-1661	9
890-245/062-000	118	890-844	114			2002-1691	9
890-255	118	890-844/011-000	115	2000-402/000-006	14	2002-1692	9
890-255/060-000	118	890-845	120				
890-255/062-000	118	890-845/011-000	121	2000-410/000-006	14	2002-1701	20
890-265	118	890-852	110			2002-1711	22
890-265/073-000	118	890-852/011-000	111	2000-433	4	2002-1711/1000-541	22
890-275	118	890-853	112			2002-1711/1000-542	22
890-275/073-000	118	890-853/011-000	113	2000-440	4	2002-1711/1000-836	22
890-285	118	890-854	114			2002-1711/1000-867	22
890-285/080-000	118	890-854/011-000	115	2000-492	6	2002-1702	20
890-285/082-000	118	890-855	120			2002-1704	20
890-295	118	890-855/011-000	121	2000-2218	4	2002-1707	20
890-295/080-000	118	890-862	110	2000-2218/099-000	5	2002-1761	23
890-295/082-000	118	890-862/011-000	111	2000-2228	4	2002-1771	20
		890-863	112	2000-2228/099-000	5	2002-1771/401-000	20
890-310	118	890-863/011-000	113	2000-2248	4	2002-1772	20
890-311	118	890-864	114	2000-2248/099-000	5	2002-1772/401-000	20
890-382	122	890-864/011-000	115	2000-2258	4	2002-1774	20
890-383	123	890-865	120	2000-2258/099-000	5	2002-1774/401-000	20
890-384	123	890-865/011-000	121	2000-2291	4	2002-1791	20
890-385	123	890-872	110	2000-2292	4	2002-1792	20
		890-872/011-000	111				
890-502/342-000	122	890-873	112	2001 Series			
890-512/342-000	122	890-873/011-000	113	2001-115	5	2002-1861	9
		890-874	114	2001-402	5	2002-1891	9
890-601	116	890-874/011-000	115			2002-1892	9
890-624	116	890-875	120	2001-410	5	2002-1961	9
890-674	116	890-875/011-000	121				
		890-882	110				

Item Number Index

Item No.	Page	Item No.	Page	Item No.	Page	Item No.	Page
2002 Series		2006 Series		2022 Series		2061 Series	
2002-1991	9	2006-8401	32	2022-103/000-038/999-953	45	2061-602/998-404	65
2002-1992	9			2022-103/000-039/999-953	45	2061-603/998-404	65
		2006-8601	32	2022-141	36		
2002-2418	7	2006-8604	32	2022-142	36	2061-621/998-404	65
2002-2428	7	2006-8661	32	2022-151	36	2061-622/998-404	65
2002-2448	7	2006-8664	32	2022-152	36	2061-623/998-404	65
2002-2458	7	2006-8671	32	2022-162	35		
2002-2491	7	2006-8674	32	2022-172	35		
2002-2492	7	2006-8691	32	2022-182	35		
		2006-8692	32				
				2022-1201/999-953	40		
2002-2601	16			2022-1202	35		
2002-2602	16			2022-1204/999-953	40		
2002-2603	16	2007 Series		2022-1207/999-953	40		
2002-2604	16	2007-8442	28	2022-1291	40		
2002-2607	16			2022-1292	40		
2002-2608	16	2007-8448	28				
2002-2609	16			2022-1301/999-953	40		
2002-2611	19	2007-8801	28	2022-1302	35		
2002-2611/1000-541	19	2007-8807	29	2022-1304/999-953	40		
2002-2611/1000-542	19	2007-8811	28	2022-1307/999-953	40		
2002-2611/1000-836	19	2007-8821	28	2022-1391	40		
2002-2612	19	2007-8873	30	2022-1392	40		
2002-2647	16	2007-8876	31				
2002-2657	16	2007-8891	28	2022-1401/999-953	40		
2002-2661	18	2007-8892	28	2022-1402	35		
2002-2662	18	2007-8893	28	2022-1404/999-953	40		
2002-2667	18	2007-8894	28	2022-1407/999-953	40		
2002-2671	18	2007-8899	28	2022-1491	41		
2002-2672	18			2022-1492	41		
2002-2691	17	2009 Series		2022-2201/999-953	42		
2002-2692	17	2009-110	4	2022-2207/999-953	42		
		2009-114	5	2022-2234/999-953	42		
2002-2941	15	2009-115	7	2022-2291	43		
2002-2944	15	2009-145	99	2022-2292	43		
2002-2991	12	2009-174	4				
2002-2992	12	2009-182	4	2059 Series			
		2009-191	7	2059-189	76		
		2009-304	11	2059-301/998-403	59		
2003 Series		2009-305	11	2059-302/998-403	59		
2003-499	10	2009-309	11	2059-303/998-403	59		
		2009-310	11				
2003-500	10			2060 Series			
		2009-402	6	2060-189	76		
2003-911	12	2009-404	6				
2003-911/1000-923	12	2009-406	6	2060-451/998-404	61		
		2009-412	9	2060-452/998-404	61		
2003-6640	10	2009-414	9	2060-453/998-404	61		
2003-6641	10	2009-416	9				
2003-6642	10			2060-471/998-404	67		
2003-6643	10	2010 Series		2060-472/998-404	67		
2003-6644	10	2010-1208	8	2060-473/998-404	67		
2003-6645	10						
2003-6646	10	2016 Series		2060-802/998-404	69		
2003-6649	10	2016-1208	8				
2003-6650	10			2060-852/998-404	63		
2003-6651	10	2020 Series		2060-872/998-404	63		
2003-6660	10	2020-103/000-036	36				
2003-6692	11	2020-103/000-037	36	2060-901	75		
2003-6693	10	2020-103/000-038	36	2060-902	75		
		2020-103/000-039	36	2060-903	75		
		2020-105/000-036	36				
2004 Series		2020-105/000-037	36	2060-1401/998-404	71		
2004-402	19	2020-105/000-038	37	2060-1402/998-404	71		
		2020-105/000-039	37	2060-1403/998-404	71		
2004-410	19						
		2022 Series		2060-1421/998-404	71		
2004-433	19	2022-100	40	2060-1422/998-404	71		
				2060-1423/998-404	71		
2004-440	19	2022-101/000-012	35				
				2060-1802/998-404	73		
2004-911	10	2022-115/000-012	35	2060-1822/998-404	73		
2006 Series		2022-102/999-953	44	2061 Series			
2006-115	28			2061-189	76		
2006-191	32	2022-108/999-953	44				
				2061-601/998-404	65		
2006-433	32						
2006-435	32						
2006-1208	8						

Item No.	Page	Item No.	Page	Item No.	Page	Item No.	Page

Algeria
please contact WAGO France

Argentina
Bruno Schillig S.A.
Arenales 4030, B1604CFD
Florida, PBA
Phone +54 11 4730 1100
Fax +54 11 4761 7244
wago@schillig.com.ar

Australia
Kontakt Group
Building Automation & WINSTA Systems
Office: 730 Springvale Rd
Mulgrave Victoria 3170
P.O. Box 3003, Wheelers Hill VIC 3150
Tel. +61 03 95602757
Fax +61 03 95601727
sales@kontaktgroup.com.au

NHP ELECTRICAL ENGINEERING PRODUCTS PTY LTD
43-67 River Street
Richmond, Victoria, 3121, P.O. Box 199
Phone +61 3 9429 2999
Fax +61 3 9429 1075
export@wago.com

Austria
WAGO Kontakttechnik Ges.m.b.H.
Laxenburger Straße 244
1230 Wien
Phone +43 1 6150780
Fax +43 1 6150775
info.at@wago.com

Azerbaijan
AZ Technics LTD
Zulfi V. Alizade
Y.Safarov str.33 , AZ1025,
Baku
Republic of Azerbaijan
Tel. +994 12 4968335
Fax +994 12 4968334
info@AZtechnics.az

Belarus
OOO FEK
pr-t Pushkina 29-B
220015 Minsk
Phone +375 17 2102189
Fax +375 17 2102189
wago@fek.by

UE ATAVA
ul. Denisovskaya, 47, office 1
220006 Minsk
Phone +375 17 2054015
Fax +375 17 2851759

Belgium
WAGO Kontakttechnik
Excelsiorlaan 11
1930 Zaventem
Phone +32 2 7179090
Fax +32 2 7179099
info-be@wago.com

Bolivia
Kohn s.r.l.
Barrio Convifag
C/Toborochi #6, Zona Norte
Santa Cruz
Tel. +591 3 3120272
Fax +591 3 3120272

Bosnia and Herzegovina
please contact WAGO Bulgaria

Brazil
WAGO Eletroeletrônicos Ltda
Rua Américo Simões 1470
São Roque da Chave
Itupeva SP Brasil 13295-000
Phone +55 11 4591 0199
Fax +55 11 4591 0190
info.br@wago.com

Bulgaria
WAGO Kontakttechnik GmbH & Co. KG/
Representative Office Sofia
Business Center Serdika
2E Akad. Ivan Geshov Blvd.
Building 1, Floor 4, Office 417
1330 Sofia
Tel. +359 2 489 46 09
Fax +359 2 928 28 50
info-BG@wago.com

Canada
please contact WAGO USA

Chile
Desimat Chile
Av Puerto Vespuccio 9670
Pudahuel Santiago
Phone +56 2 7470152
Fax +56 2 7470153
ventaschile@desimat.cl

China
WAGO ELECTRONIC (TIANJIN) Co. LTD
No.5, Quan Hui Road, Wuqing Development Area
Tianjin 301700
Phone +86 22 59617688
Fax +86 22 59617668
info-cn@wago.com

Columbia
T.H.L. Ltda.
Cra. 49 B # 91-33
Bogotá
Phone +57 1 621 85 50
Fax +57 1 621 60 28
ventas.thl@thltda.com

Croatia
M.B.A. d.o.o. za trgovinu i zastupanje
Frana Supila 5
51211 Matulji HR
Phone +385 51 275-736
Fax +385 51 275-066
mba@ri.hinet.hr

GENERA CTR d.o.o.
- just for automation technology -
Siget 18 b
10020 Zagreb
Phone +385 13647849
Fax +385 13636662
wago@geneza.hr

Czech Republic
WAGO Elektro spol. sr. o.
Rozvodova 1116/36
143 00 Praha 4 - Modřany
Phone +420 261 090 143
Fax +420 261 090 144
info.cz@wago.com

Denmark
WAGO Danmark
Filial of WAGO Kontakttechnik GmbH & Co. KG
Lejrvej 17
3500 Værløse
Phone +45 44 357777
Fax +45 44 357787
salg.dk@wago.com

Ecuador
ECUAINSETEC CIA LTDA
El Zurriago E9-32 y el Vengador
Quito
Tel. +593 2 2 26 91 48
Fax +593 2 2 46 18 33
g.castro@ecuainsetec.com.ec

Egypt
IBN Engineering Instrumentation & Control
71 a ElShaheed Ahmed Hamdi St.
King Faisal, Giza
Phone +20 2 7214350
Fax +20 2 7221709
sales@ibnengineering.com

Estonia
Eltarko OÜ
Laki 14 - 502
10621 Tallinn
Phone +372 651 7731
Fax +372 651 7786
andres@eltarko.ee

Finland
WAGO Kontakttechnik GmbH & Co. KG
Filial i Finland
Vellamonkatu 30 B
00550 Helsinki
Phone +358 9 7744 060
Fax +358 9 7744 0660
tilaus@wago.fi

France
WAGO CONTACT SAS
Paris Nord 2
83 Rue des Chardonnerets
B.P. 55065 - Tremblay en France
95947 - ROISSY CDG CEDEX
Phone +33 1 48 172590
Fax +33 1 48 632520
info-fr@wago.com

Germany
WAGO Kontakttechnik GmbH & Co. KG
Postfach 28 80, 32385 Minden
Hansastraße 27
32423 Minden
Phone +49 571 887-0
Fax +49 571 887-169
info@wago.com

WAGO Kontakttechnik GmbH & Co. KG
Waldstraße 1
99706 Sondershausen
Phone +49 3632 659-0
Fax +49 3632 659-100
info@wago.com

Great Britain
WAGO Limited
Triton Park, Swift Valley Industrial Estate
RUGBY
Warwickshire, CV21 1SG
Phone +44 1788 568008
Fax +44 1788 568050
uksales@wago.com

Greece
PANAGIOTIS SP. DIMOULAS - BIOMAT
DIMOULAS AUTOMATIONS
Kritis Str. 26
10439 Athen
Tel. +30 210 883 3337
Fax +30 210 883 4436
wago.info@dimoulas.com.gr

Honduras
CILASAS S.A. de C.V.
Barrio los Andes
7 Calle entre 14 y 15 Ave. N.O.
P.O. Box. 1061
San Pedro Sula
Tel. +504 25571146/7
Fax +504 25571149

Hong Kong
National Concord Eng., Ltd.
Unit A-B, 5/F,
Southeast Industrial Building
611-619 Castle Peak Road
Tsuen Wan, N.T.
Phone +852 24292611
Fax +852 24292164
sales@nce.com.hk

Hungary
WAGO Hungária KFT
Ipari Park, Gyár u. 2
2040 Budapest
Phone +36 23 502-170
Fax +36 23 502-166
info.hu@wago.com

Iceland
S. Gudjonsson ehf.
Audbrekkur 9-11
202 Kopavogur
Phone +354 520-4500
Fax +354 520-4501
export@wago.com

India
WAGO LTD.
C-27, Sector-58, Phase-III
Noida-201 301
Gautam Budh Nagar (U.P.)
Tel. +91 120 2 580409 10
Fax +91 120 2 580081
info@wagoindia.com

Indonesia
please contact WAGO Singapore

Iraq
please contact WAGO Middle East

Ireland
Drives & Controls
Unit F4, Riverview Business Park
Nangor Road
Dublin 12
Phone +353 1 4604474
Fax +353 1 4604507
wago@drivesandcontrols.ie

Israel
Comtel Israel Electronic Solutions Ltd.
Bet Hapaamon
20 Hataas Street
P.O. Box 66
44425 Kefar-Saba
Phone +972 9 76 77 240
Fax +972 9 76 77 243
sales@comtel.co.il

Italy
WAGO ELETTRONICA SRL a Socio Unico
Via Parini 1
40033 Casalecchio di Reno (BO)
Tel. +39 051 6132112
Fax +39 051 6272174
info-ita@wago.com

Japan
WAGO Co. of JAPAN Ltd.
Nittetsu ND-Tower Building 4F
5-7, Kameido 1-chome
Koto-Ku
Tokyo 136-0071
Tel. +81 3 5627 2050
Fax +81 3 5627 2055
info-jp@wago.com

Jordan
please contact WAGO Middle East

Kazakhstan
TOO INTANT
ul. Muratbaeva, d. 61
050026 Almaty
Tel. +7 727 2371492
Fax +7 727 2980151
info@intant.kz

TOO Technik-Trade
ul. i. A. Protosanova, 81
070004 Ust-Kamenogorsk
Tel. +7 7232 254064
Fax +7 7232 253251
info@technik.kz

ITC Electronics: Almaty
Prospekt Raiymbeka 221 ?/4
050016 Almaty
Kazakhstan
Tel. +7 727 2797117
Fax +7 727 2339344

Korea
WAGO Korea Co., Ltd.
#205 Anyang Mega Valley
Dongan-gu, Anyang-si
Kyunggi-do, South Korea
Phone +82 3142 12470
export@wago.com

Kosovo
please contact WAGO Bulgaria

Latvia
INSTABALT LATVIA SIA
Vestienas iela 6
Riga, LV-1035
Phone +371 790 1188
Fax +371 790 1180
info@instabalt.lv

Lebanon
Gemayel Trading & Contracting
Antonins Project
P.O. BOX 70-1096
Antelias, Lebanon
Phone +961 4 521 029
Fax +961 4 521 029
gtc.libanon@gmail.com

Lithuania
INSTABALT LIT UAB
Savanoriu 187
Vilnius, 2053
Phone +370 52 322 295
Fax +370 52 322 247
info@instabalt.lt

Luxembourg

please contact WAGO Belgium

Macedonia

please contact WAGO Bulgaria

Kompjinet Inzenering
Vladimir Komarov 1A-3/9
1000 Skopje
Republic of Macedonia
Tel. +389 2 521 12 00
Tel. +389 2 246 11 08

Malaysia

WAGO Representative Office Malaysia
No. 806, Block A4, Leisure Commerce Square,
No. 9, Jalan PJS 8/9, 46150 Petaling Jaya,
Selangor Darul Ehsan, Malaysia
Tel. +60 3 7877 1776
Fax +60 3 7877 2776
kian.guan.tan@wago.com

HPH Materials (M) Sdn Bhd
No. 4, Jalan Nilam 1/6
Suban Hi-Tech Industrial Park
40000 Shah Alam
Selangor, D.E. Malaysia
Tel. +60 3 5638 2213
Fax +60 3 5638 8213
info@hphmaterials.com

Setia Raya Teknik Sdn. Bhd.
40 & 42 Jalan SS15/4
Subang Jaya 47500 P.J.
Selangor D.E. Malaysia
Tel. +60 3 5633 5511
Tel. +60 3 5633 3411
sales@setiaraya.com.my

Mexico

WAGO SA de CV
Av. Del Marques 38 Bodega 3
P. I. Bernardo Quintana
76240 El Marques, Querétaro
Phone +52 442 221 5946
Fax +52 442 221 5063
Toll-Free: 001-800-309-5975
info.mx@wago.com

Moldova

Electroservice Slavinschi T.T.
str. Bolgarskaia 9, office 6
2001 Kishinev
Phone +373 22 274427
Fax +373 22 224481
es@es.mldnet.com

Morocco

please contact WAGO France

Netherlands

WAGO Nederland
Laan van de Ram 19
7234 BW APELDOORN
Tel. +31 55 36 83 500
Fax +31 55 36 83 599
info-nl@wago.com

New Zealand

NHP NZ
7 Lockhart Place
Mt Wellington
New Zealand
Phone +64 9 2761967
Fax +64 9 2761992
export@wago.com

Nigeria

GIL Automations Ltd.
Daily Times Complex
2 Lateef Jakande Rd., Agidingbi
100271 Ikeja, Lagos State
Tel. +234 17132672335
sales@gilautomation.com

Norway

WAGO Norge NUF
Jerikoveien 20
1067 Oslo
Phone +47 22 30 94 50
Fax +47 22 30 94 51
info.no@wago.com

Oman

please contact WAGO Middle East

Pakistan

Fuzilogix Automation & Control
Suite No. 14, 5th Floor, Shan Arcade
New Garden Town, Lahore
Pakistan
Phone +92 42 594 1503 - 4
Fax +92 42 585 1431
info@fuzilogix.com

Peru

Manufacturas Eléctricas S.A.
Av. O.R. Benavides 1215
15000 Lima
Tel. +511 6196200
Fax +511 6196247

Philippines

please contact WAGO Singapore

Poland

WAGO ELWAG sp. z o. o.
ul. Piekna 58 a
50-506 Wrocław
Phone +48 71 3602970
Fax +48 71 3602999
wago.elwag@wago.com

Portugal

MORGADO & CA. LDA - SEDE
Estrada Exterior da
Circunvalação 3558/3560
Apartado 1057
4435 Rio Tinto
Phone +351 22 9770600
Fax +351 22 9770699
geral@morgadocl.pt

Quatar

please contact WAGO Middle East

Romania

WAGO Kontakttechnik GmbH & Co. KG/
Representative Office Bukarest
Str. Nicolae G. Caramfil Nr. 26
Bl. 1D, Et. 3, Ap. 7, Sect. 1, OP 52
014144-Bucuresti
Tel. +40-(0)31 421 85 68
info-RO@wago.com

VDR & Servicii srl
Str. Valeriu Braniste, nr. 60, ap.1, sector 3
Romania
Tel. +40 21 3225074/76
Fax +40 21 3225075
office@componente-automatizari.ro

Russia

OOO WAGO Kontakt Rus
Dmitrovskoe shosse, 157, bldg. 12/5
127411 Moscow
Russia
Phone +7 495 663-3305
Fax +7 495 663-3308
info.ru@wago.com

WAGO Branch office
Ekaterinburg
Tel. +7 343 216 3426

WAGO Branch office
Novosibirsk
Tel. +7 383 217 9244

WAGO Branch office
St. Petersburg
Tel. +7 812 312 1918

Saudi Arabia

Saudi Electronic Trading Company (SETRA)
P.O. Box 60712
11555-Riyadh
Tel. +966 1 2062277
Fax +966 1 2062277
khaled.wafai@setra.com.sa

Serbia

über WAGO Bulgarien

Avalon Partners doo
Patrijarha Dimitrija 24
11000 Beograd
Tel. +381 11 2685311
Fax +381 11 2685311
office@avalon.rs

Sigma doo
Balzakova 3
21000 Novi Sad
Tel. +381 21 468431
Fax +381 21 6361785
office@sigmadoo.co.rs

Singapore

WAGO Electronic Pte Ltd
10 Upper Aljunied Link
#04-04 Johnson Controls Building
Singapore 367904
Phone +65 62866776
Fax +65 62842425
info-sing@wago.com

Slovakia

WAGO Elektrik spol. s r. o.
Odborárska 52
83102 Bratislava
Tel. +421 2 45692503
export@wago.com

Proelektro spol. s r.o.

Na barine 22
841 03 Bratislava - Lamač
Tel. +421 2 4569 2503
info@wago.sk

Slovenia

GENERA d.o.o.
Prevale 10
1236 Trzin
Phone +386 14393050
Fax +386 14393090
genera@genera.si

IC elektronika d.o.o.

Vodovodna cesta 100
1000 Ljubljana
Phone +386 15680110
Fax +386 15689107
info@ic-elect.si

South Africa

Shorrock Automation (Pty) Ltd
Postnet Suite # 219
Private Bag X 8, Elardus Park
0047 PRETORIA
Tel. +27 12 4500300
Fax +27 12 4500322
sales@shorrock.co.za

Spain

DICOMAT S.L.
Avda. de la Industria, 36
Apartado Correos, 1.178
28108 - Alcobendas (Madrid)
Phone +34 91 6621362
Fax +34 91 6610089
info@dicomat.com

Sweden

WAGO Sverige
WAGO Kontakttechnik GmbH
Tyskland Filial
Box 11127, 161 11 BROMMA
Besöksadress: Adolfsbergsv. 31
Tel. +46 858410680
Fax +46 858410699
info.se@wago.com

Switzerland

WAGO CONTACT SA
Rte. de l'Industrie 19
Case Postale 168
1564 Domdidier
Phone +41/26 676 75 86
Fax +41/26 676 75 01
info.switzerland@wago.com

Syria

Zahabi Co.
8/5 Shouhadaa St., P.O. Box 8262
Aleppo
Phone +963 21 21 22 235 / 6
Fax +963 21 21 24 768
info.uae@wago.com

Taiwan R.O.C.

WAGO Contact, Ltd.
5F, No.168, Jiankang Rd
Zhonghe City
Taipei County 23585, Taiwan
Phone +886 2 22250123
Fax +886 2 22251511
info.taiwan@wago.com

Thailand

WAGO Representative Office Thailand
4th Floor, KS Building
213/6-8 Rachada-Phisek Road
Dingdaeng, Bangkok 10320
Tel. +66 2 6935611
Fax +66 2 6935612
wago@truemail.co.th

US Power Distribution Co., Ltd.
4th Floor K.S. Building
213/6-8 Rachada Phisek Road
Ding Daeng, Bangkok 10400
Tel. +66 2 2763040
Fax +66 2 2763049
wago@truemail.co.th

Tunisia

please contact WAGO France

Turkey

WAGO Elektronik Sanayi ve Ticaret Ltd. Şti.
Yukan Dudullu Mahallesi Bayraktar Bulvan
Cad. Hattat Sok. No. 10
34775 Umraniye - Istanbul
Turkey
Tel. +90 216 472 1133
Fax +90 216 472 9910
info.tr@wago.com

Ukraine

NPP Logicon
Predslavinskaya street, 39, office 303
03150 Kiev
Tel. +380 44 5228019
Fax +380 44 2611803
info@logicon.ua

OOO Mikropribor
ul. Kotelnikova, 4
03115 Kiev
Tel. +380 44 5369386
Fax +380 44 5369387
sales@micropribor.kiev.ua

ITC Electronics: Kiev
pr. Vossovrednieniya 7a
office 107
02160 Kiev
Tel. +38 44 5596890
Fax +38 44 5011303
kiev@itc-electronics.com

United Arab Emirates (UAE)

WAGO Middle East (FZC)
SAIF Zone, Q4-282
P.O. Box: 120665
Sharjah, UAE
Phone +971 6 5579920
Fax +971 6 5579921
info.uae@wago.com

USA

WAGO Corporation
N120 W19129 Freistadt Road
Germantown, WI 53022
Phone +1 262 255 6222
Fax +1 262 255 3232
Toll-Free: 1-800 DIN Rail (346-7245)
info.us@wago.com

Venezuela

PETROBORNAS, C.A.
C.C. PLAZA AEROPUERTO - PISO 1 - LOCAL P1 - B - 03
(8015) UNARE - PUERTO ORDAZ - ESTADO BOLIVAR
REPÚBLICA BOLIVARIANA DE VENEZUELA
Tel. +58 286 951 3382
Fax +58 286 951 3382
info@petrobornas.com

Vietnam

please contact WAGO Germany (Minden)

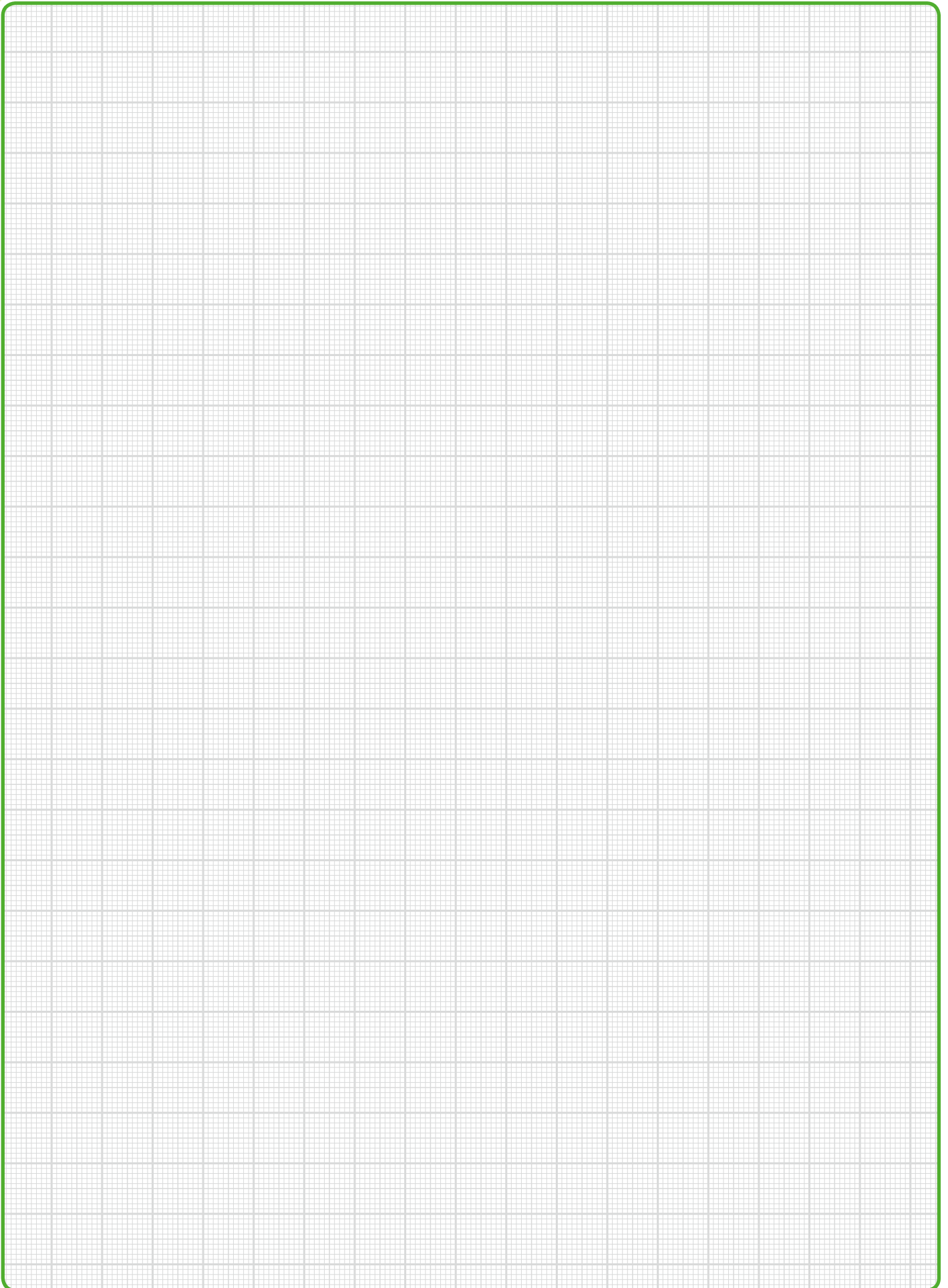

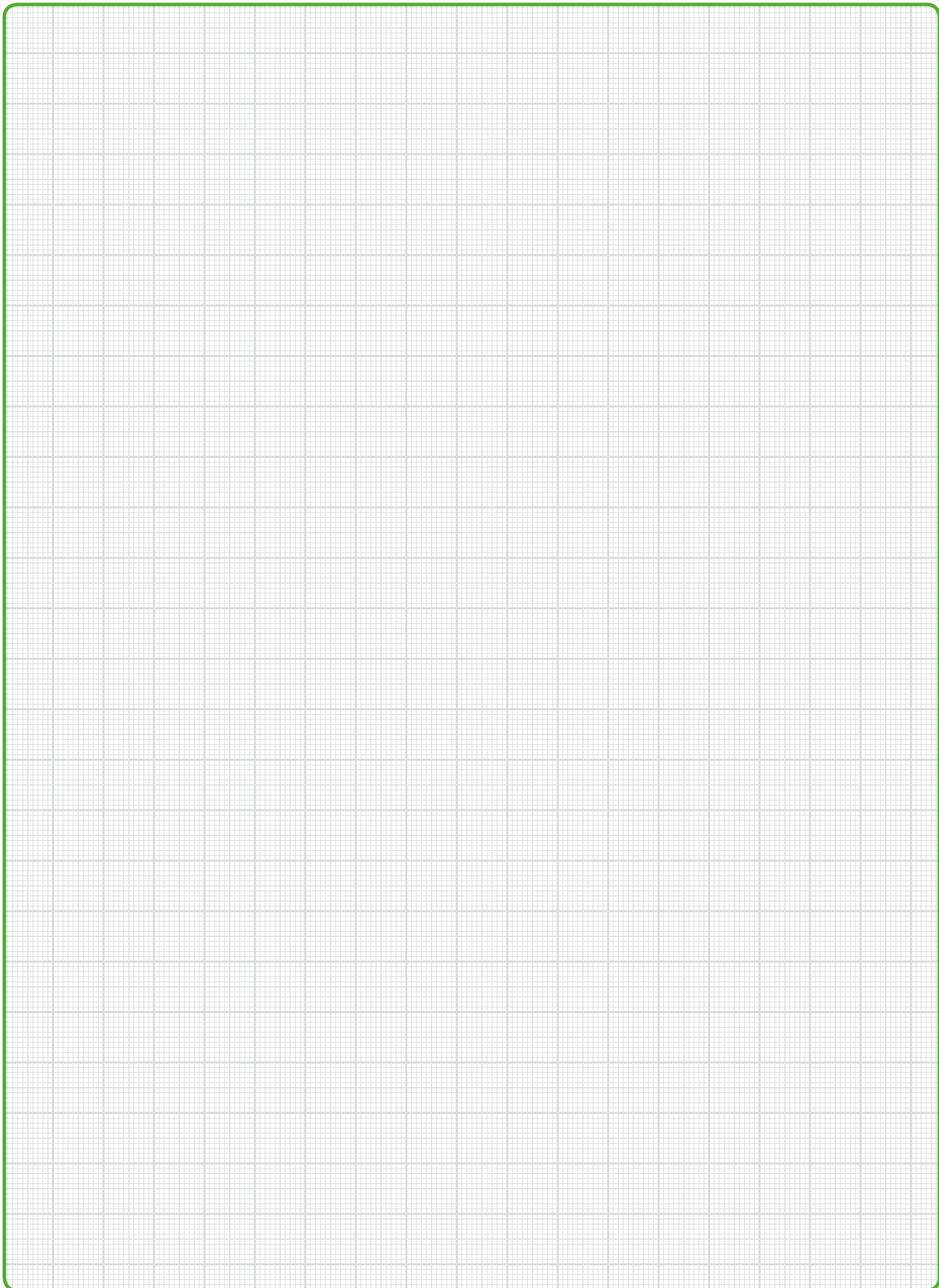

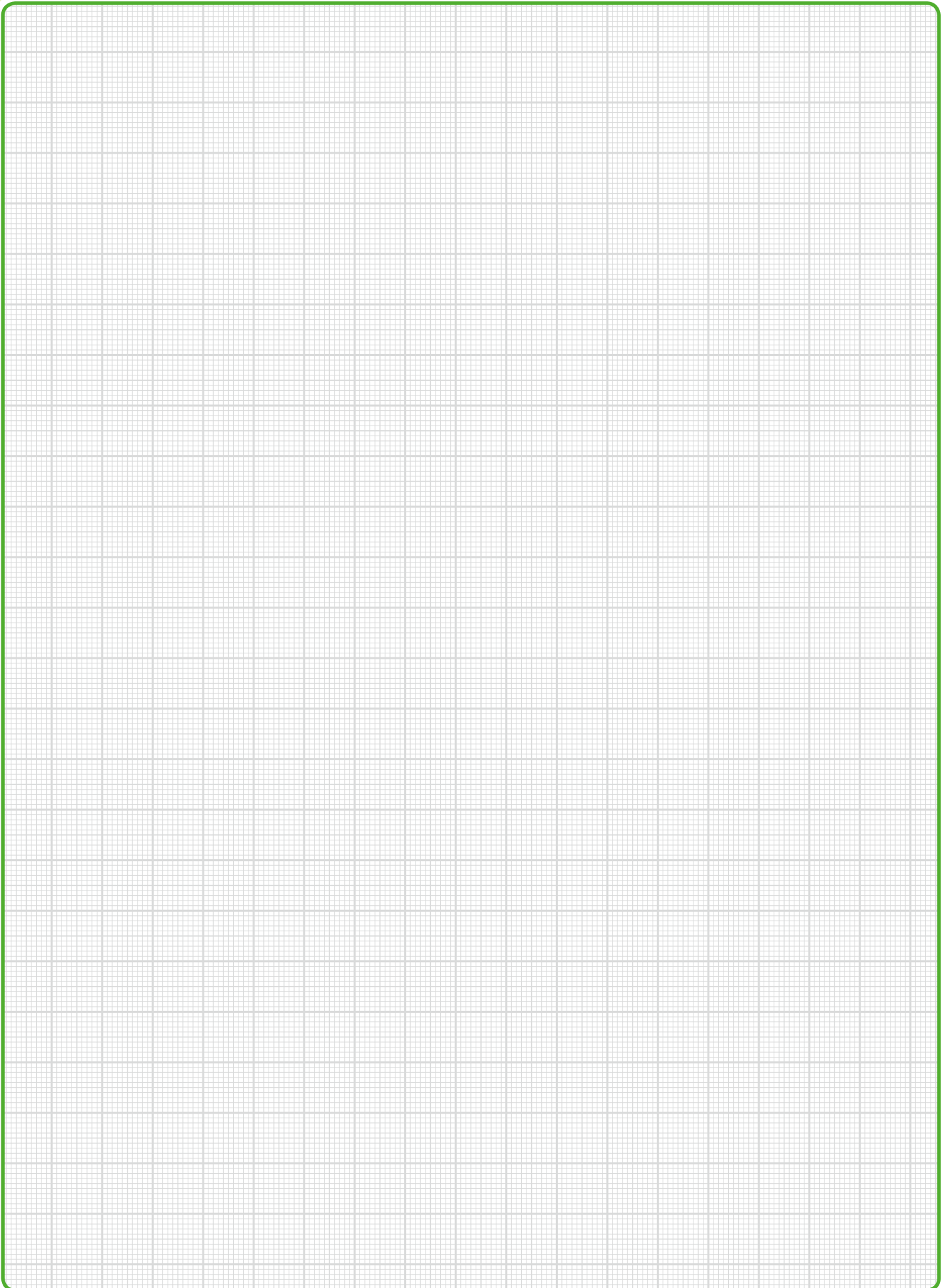

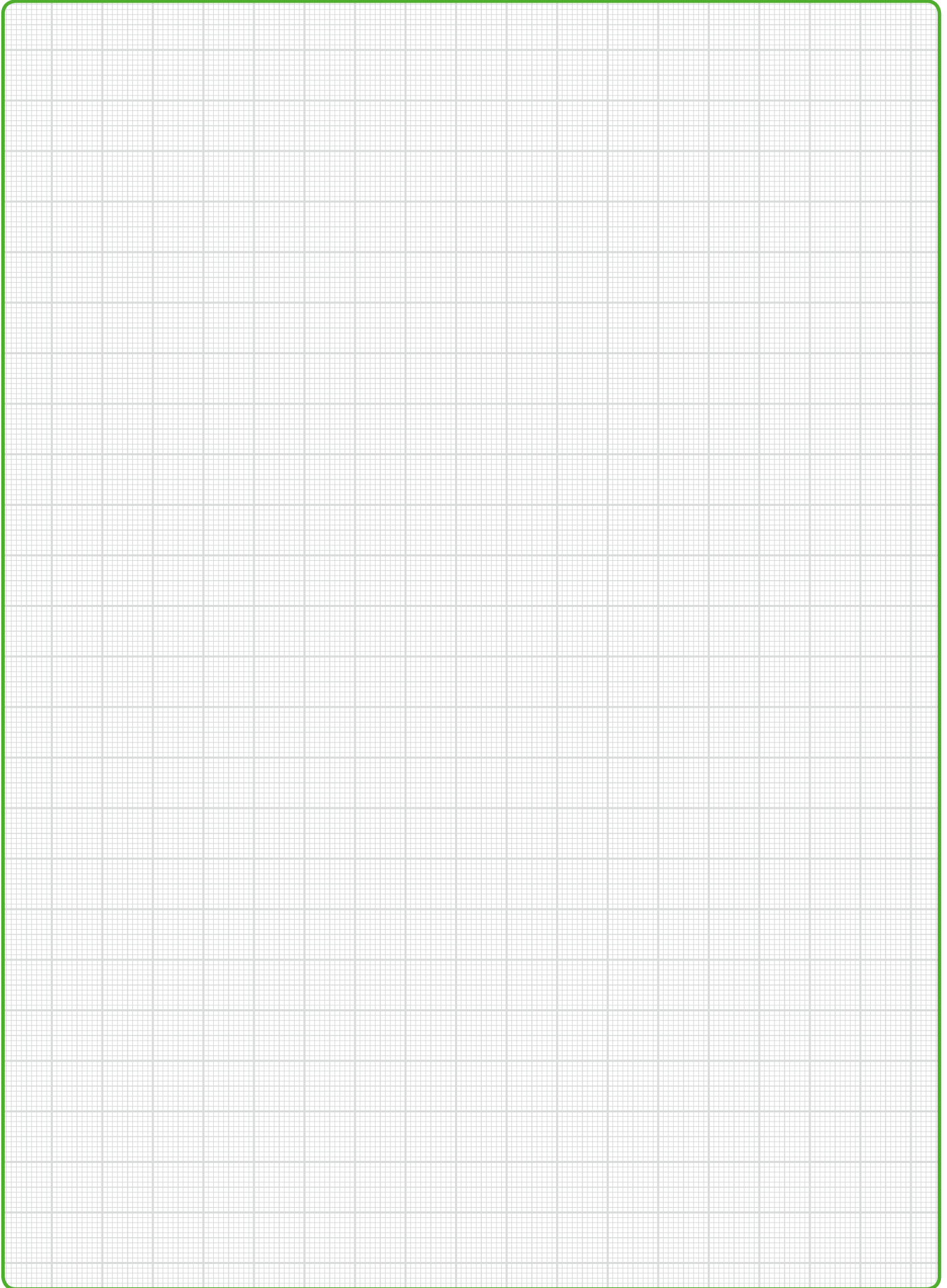

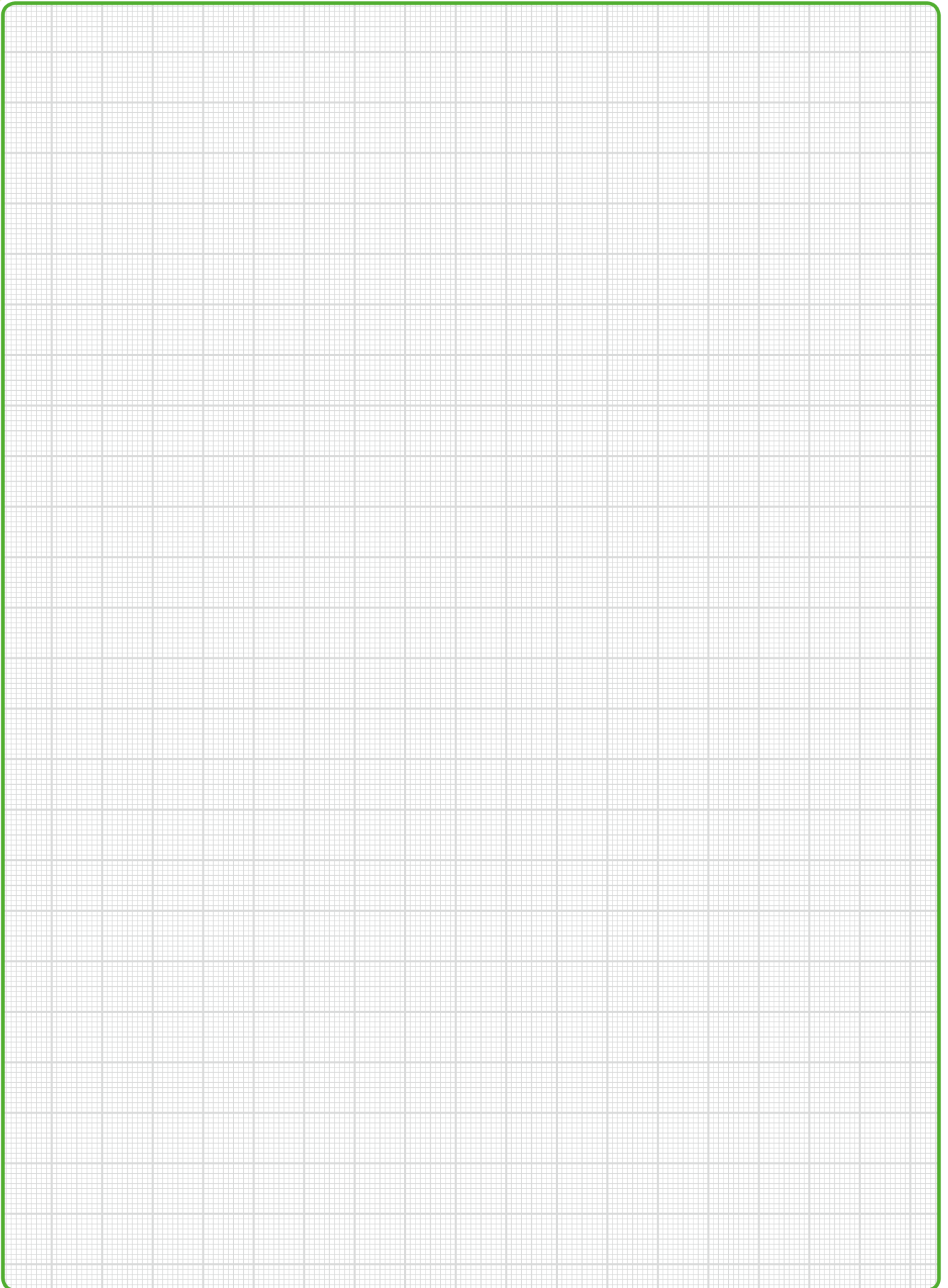

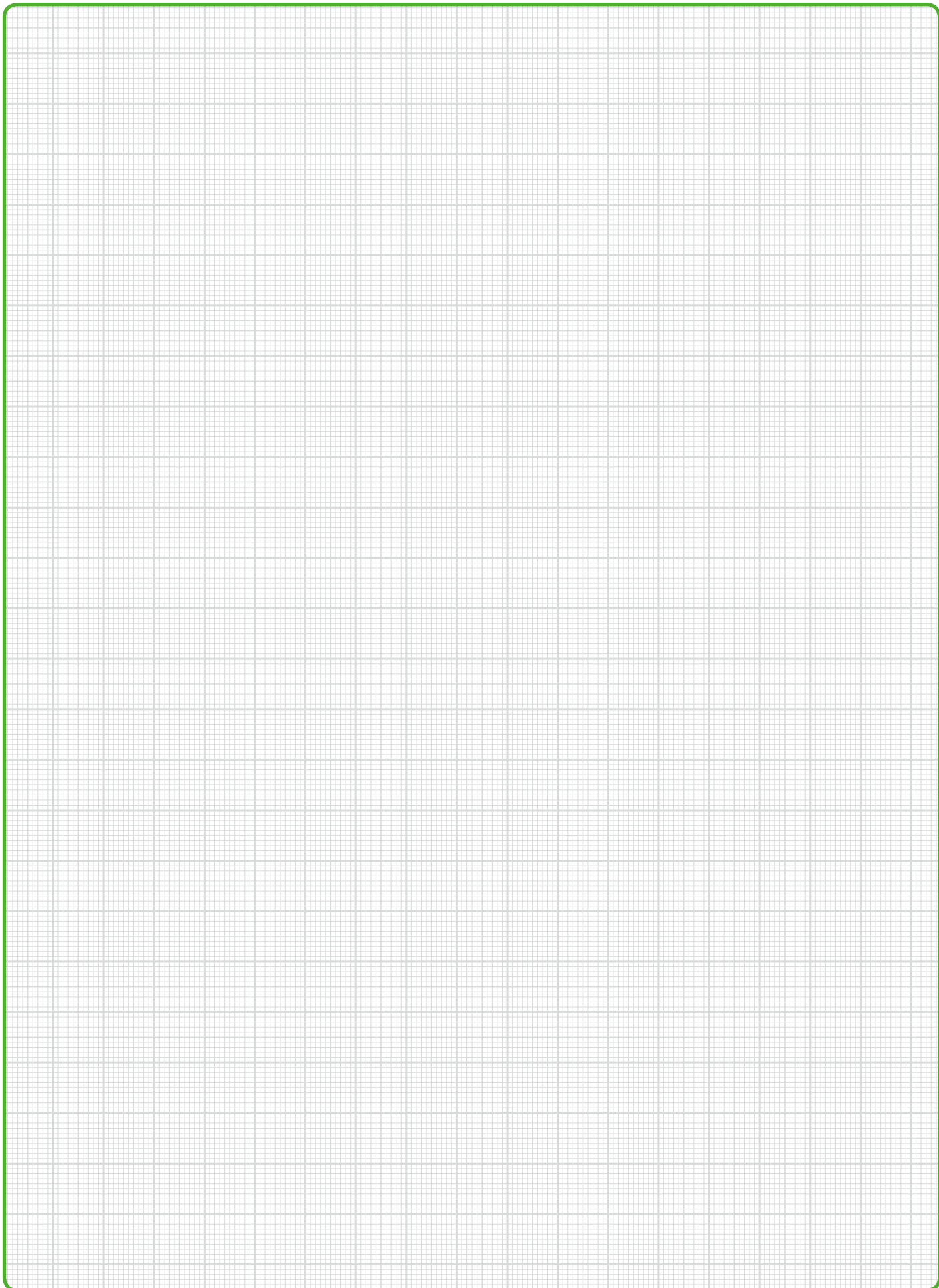

WE! INNOVATE!

WAGO Kontakttechnik GmbH & Co. KG
Postfach 2880 · D - 32385 Minden
Hansastraße 27 · D - 32423 Minden
Germany
Phone: +49 571 887 - 0
Fax: +49 571 887 - 169
E-Mail: info@wago.com
Online: www.wago.com



X-ON Electronics

Largest Supplier of Electrical and Electronic Components

Click to view similar products for [wago manufacturer](#):

Other Similar products are found below :

[750-460](#) [231-118/026-000](#) [231-303/026-000](#) [231-620/019-000](#) [257-403](#) [280-438](#) [280-831](#) [284-624](#) [210-111](#) [231-303/037-000](#) [231-446/001-000_NR](#) [232-216/026-000](#) [234-510](#) [264-726](#) [280-339](#) [0283-0671](#) [830-800/000-305](#) [750-512](#) [750-455](#) [51251782](#) [286-312](#) [713-1428/107-000](#) [731-138/048-000](#) [750-459](#) [750-517](#) [750-602](#) [793-3505](#) [826-172](#) [859-304](#) [280-335](#) [231-535/001-000](#) [2604-1105](#) [2604-1106](#) [2604-1504](#) [2606-1103/020-000](#) [2624-1103](#) [2626-3103/020-000](#) [821-104](#) [713-1107](#) [852-1411](#) [2106-1307](#) [2116-5307](#) [832-1205](#) [832-3604](#) [2009-110](#) [281-512/281-501](#) [286-336](#) [750-421](#) [750-838](#) [753-559](#)