Full-Featured 28/40/44-Pin Microcontrollers

Description

PIC16(L)F18856/76 microcontrollers feature Analog, Core Independent Peripherals and Communication Peripherals, combined with eXtreme Low-Power (XLP) technology for a wide range of general purpose and low-power applications. The family will feature the CRC/SCAN, Hardware Limit Timer (HLT) and Windowed Watchdog Timer (WWDT) to support customers looking to add safety to their application. Additionally, this family includes up to 28 KB of Flash memory, along with a 10-bit ADC with Computation (ADC²) extensions for automated signal analysis to reduce the complexity of the application.

Core Features

- C Compiler Optimized RISC Architecture
- Only 49 Instructions
- Operating Speed:
 - DC – 32 MHz clock input
 - 125 ns minimum instruction cycle
- Interrupt Capability
- 16-Level Deep Hardware Stack
- Three 8-Bit Timers (TMR2/4/6) with Hardware Limit Timer (HLT) Extensions
- Four 16-Bit Timers (TMR0/1/3/5)
- Low-Current Power-on Reset (POR)
- Configurable Power-up Timer (PWRTE)
- Brown-out Reset (BOR) with Fast Recovery
- Low-Power BOR (LPBOR) Option
- Windowed Watchdog Timer (WWDT):
 - Variable prescaler selection
 - Variable window size selection
 - All sources configurable in hardware or software
- Programmable Code Protection

Memory

- Up to 28 KB Flash Program Memory
- Up to 2 KB Data SRAM
- 256B of EEPROM
- Direct, Indirect and Relative Addressing modes

Operating Characteristics

- Operating Voltage Range:
 - 1.8V to 3.6V (PIC16LF18856/76)
 - 2.3V to 5.5V (PIC16F18856/76)
- Temperature Range:
 - Industrial: -40°C to 85°C
 - Extended: -40°C to 125°C

Power-Saving Functionality

- DOZE mode: Ability to run the CPU core slower than the system clock
- IDLE mode: Ability to halt CPU core while internal peripherals continue operating
- Sleep mode: Lowest Power Consumption
- Peripheral Module Disable (PMD):
 - Ability to disable hardware module to minimize power consumption of unused peripherals

eXtreme Low-Power (XLP) Features

- Sleep mode: 50 nA @ 1.8V, typical
- Watchdog Timer: 500 nA @ 1.8V, typical
- Secondary Oscillator: 500 nA @ 32 kHz
- Operating Current:
 - 8 μ A @ 32 kHz, 1.8V, typical
 - 32 μ A/MHz @ 1.8V, typical

Digital Peripherals

- Four Configurable Logic Cells (CLC):
 - Integrated combinational and sequential logic
- Three Complementary Waveform Generators (CWG):
 - Rising and falling edge dead-band control
 - Full-bridge, half-bridge, 1-channel drive
 - Multiple signal sources
- Five Capture/Compare/PWM (CCP) module:
 - 16-bit resolution for Capture/Compare modes
 - 10-bit resolution for PWM mode
- 10-bit PWM:
 - Two 10-bit PWMs
- Numerically Controlled Oscillator (NCO):
 - Generates true linear frequency control and increased frequency resolution
 - Input Clock: $0 \text{ Hz} < F_{\text{NCO}} < 32 \text{ MHz}$
 - Resolution: $F_{\text{NCO}}/2^{20}$
- Two Signal Measurement Timers (SMT):
 - 24-bit Signal Measurement Timer
 - Up to 12 different Acquisition modes

PIC16(L)F18856/76

Digital Peripherals (Cont.)

- Cyclical Redundancy Check (CRC/SCAN):
 - 16-bit CRC
 - Scans memory for NVM integrity
- Communication:
 - EUSART, RS-232, RS-485, LIN compatible
 - Two SPI
 - Two I²C, SMBus, PMBus™ compatible
- Up to 36 I/O Pins:
 - Individually programmable pull-ups
 - Slew rate control
 - Interrupt-on-change with edge-select
 - Input level selection control (ST or TTL)
 - Digital open-drain enable
 - Current mode enable
- Peripheral Pin Select (PPS):
 - Enables pin mapping of digital I/O
- Data Signal Modulator (DSM)
 - Modulates a carrier signal with digital data to create custom carrier synchronized output waveforms

Analog Peripherals

- Analog-to-Digital Converter with Computation (ADC²):
 - 10-bit with up to 35 external channels
 - Automated post-processing
 - Automates math functions on input signals: averaging, filter calculations, oversampling and threshold comparison
 - Operates in Sleep
- Two Comparators (COMP):
 - Fixed Voltage Reference at (non) inverting input(s)
 - Comparator outputs externally accessible
- 5-Bit Digital-to-Analog Converter (DAC):
 - 5-bit resolution, rail-to-rail
 - Positive Reference Selection
 - Unbuffered I/O pin output
 - Internal connections to ADCs and comparators
- Voltage Reference:
 - Fixed Voltage Reference with 1.024V, 2.048V and 4.096V output levels

Flexible Oscillator Structure

- High-Precision Internal Oscillator:
 - Software selectable frequency range up to 32 MHz, ±1% typical
- x2/x4 PLL with Internal and External Sources
- Low-Power Internal 32 kHz Oscillator (LFINTOSC)
- External 32 kHz Crystal Oscillator (SOSC)
- External Oscillator Block with:
 - Three crystal/resonator modes up to 20 MHz
 - Three external clock modes up to 20 MHz
- Fail-Safe Clock Monitor:
 - Allows for safe shutdown if peripheral clock stops
- Oscillator Start-up Timer (OST)
 - Ensures stability of crystal oscillator resources

PIC16(L)F18856/76

PIC16(L)F188XX Family Types

Device	Data Sheet Index	Program Flash Memory (Words)	Program Flash Memory (KB)	EEPROM (bytes)	Data SRAM (bytes)	I/O Pins ⁽¹⁾	10-Bit ADC ² (ch)	5-Bit DAC	Comparator	8-Bit (with HLT)/16-Bit Timers	SMT	Windowed Watchdog Timer	CRC and Memory Scan	CCP/10-Bit PWM	Zero-Cross Detect	CWG	NCO	CLC	DSM	EUSART/I ² C/SPI	Peripheral Pin Select	Peripheral Module Disable
PIC16(L)F18854	(1)	4096	7	256	512	25	24	1	2	3/4	2	Y	Y	5/2	Y	3	1	4	1	1/2	Y	Y
PIC16(L)F18855	(2)	8192	14	256	1024	25	24	1	2	3/4	2	Y	Y	5/2	Y	3	1	4	1	1/2	Y	Y
PIC16(L)F18856	(3)	16384	28	256	2048	25	24	1	2	3/4	2	Y	Y	5/2	Y	3	1	4	1	1/2	Y	Y
PIC16(L)F18857	(4)	32768	56	256	4096	25	24	1	2	3/4	2	Y	Y	5/2	Y	3	1	4	1	1/2	Y	Y
PIC16(L)F18875	(2)	8192	14	256	1024	36	35	1	2	3/4	2	Y	Y	5/2	Y	3	1	4	1	1/2	Y	Y
PIC16(L)F18876	(3)	16384	28	256	2048	36	35	1	2	3/4	2	Y	Y	5/2	Y	3	1	4	1	1/2	Y	Y
PIC16(L)F18877	(4)	32768	56	256	4096	36	35	1	2	3/4	2	Y	Y	5/2	Y	3	1	4	1	1/2	Y	Y

Note 1: One pin is input-only.

Data Sheet Index: (Unshaded devices are described in this document)

- 1: DS40001826 [PIC16\(L\)F18854 Data Sheet, 28-Pin, Full-Featured 8-bit Microcontrollers](#)
- 2: DS40001802 [PIC16\(L\)F18855/75 Data Sheet, 28/40-Pin, Full-Featured 8-bit Microcontrollers](#)
- 3: DS40001824 [PIC16\(L\)F18856/76 Data Sheet, 28/40-Pin, Full-Featured 8-bit Microcontrollers](#)
- 4: DS40001825 [PIC16\(L\)F18857/77 Data Sheet, 28/40-Pin, Full-Featured 8-bit Microcontrollers](#)

Note: For other small form-factor package availability and marking information, please visit <http://www.microchip.com/packaging> or contact your local sales office.

PIC16(L)F18856/76

TABLE 1: PACKAGES

Packages	(S)PDIP	SOIC	SSOP	QFN (6x6)	UQFN (4x4)	TQFP	QFN (8x8)	UQFN (5x5)
PIC16(L)F18856	•	•	•	•	•			
PIC16(L)F18876	•					•	•	•

Note: Pin details are subject to change.

PIN DIAGRAMS

28-pin SPDIP, SOIC, SSOP

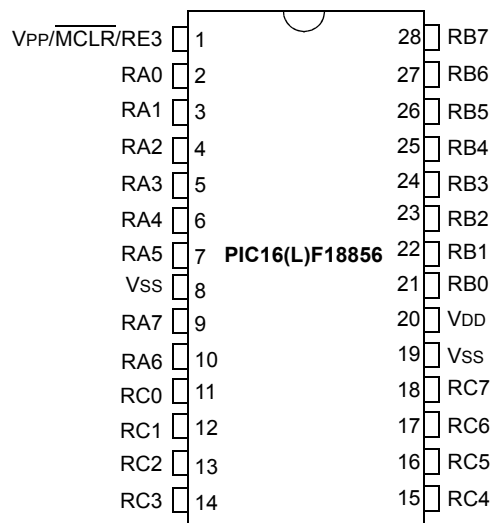

Note 1: See [Table 2](#) for location of all peripheral functions.

2: All VDD and all Vss pins must be connected at the circuit board level. Allowing one or more Vss or VDD pins to float may result in degraded electrical performance or non-functionality.

PIC16(L)F18856/76

28-pin QFN (6x6), UQFN (4x4)

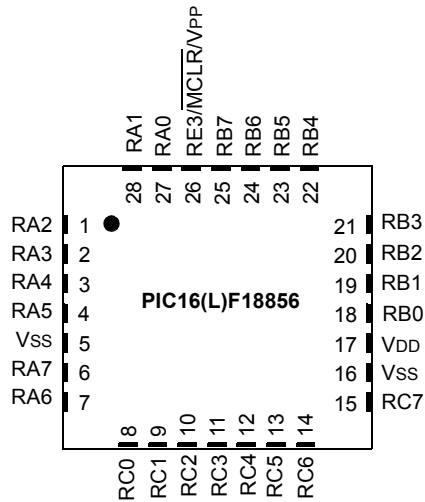

Note 1: See [Table 2](#) for location of all peripheral functions.

Note 2: All VDD and all VSS pins must be connected at the circuit board level. Allowing one or more VSS or VDD pins to float may result in degraded electrical performance or non-functionality.

Note 3: The bottom pad of the QFN/UQFN package should be connected to VSS at the circuit board level.

40-pin PDIP

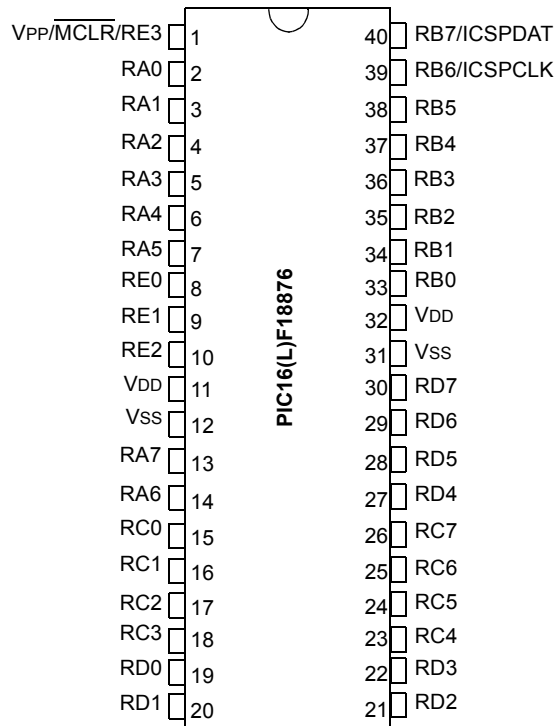

Note 1: See [Table 3](#) for location of all peripheral function.

Note 2: All VDD and all VSS pins must be connected at the circuit board level. Allowing one or more VSS or VDD pins to float may result in degraded electrical performance or non-functionality.

PIC16(L)F18856/76

40-pin UQFN (5x5)

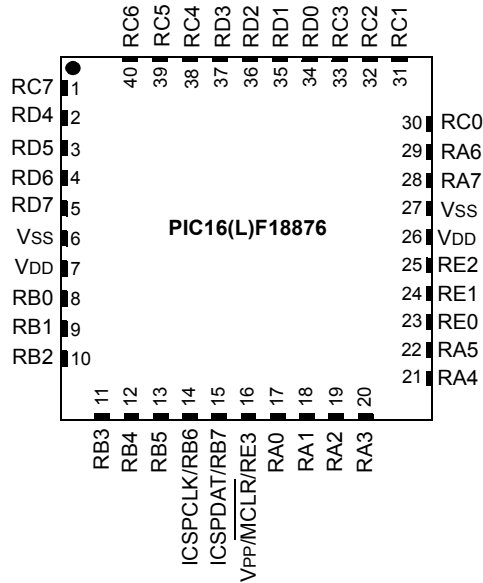

- Note 1:** See [Table 3](#) for location of all peripheral functions.
- Note 2:** All VDD and all Vss pins must be connected at the circuit board level. Allowing one or more Vss or VDD pins to float may result in degraded electrical performance or non-functionality.
- Note 3:** The bottom pad of the QFN/UQFN package should be connected to Vss at the circuit board level.

44-pin TQFP (10x10)

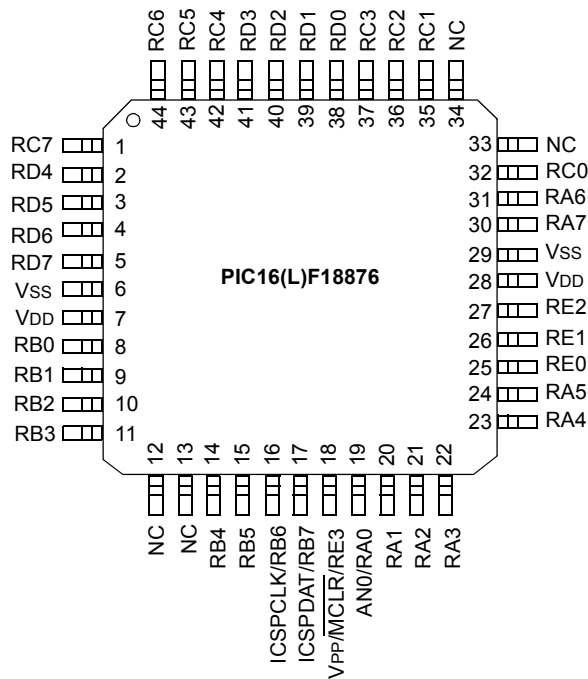

- Note 1:** See [Table 3](#) for location of all peripheral functions.
- Note 2:** All VDD and all Vss pins must be connected at the circuit board level. Allowing one or more Vss or VDD pins to float may result in degraded electrical performance or non-functionality.

PIC16(L)F18856/76

44-pin QFN (8x8)

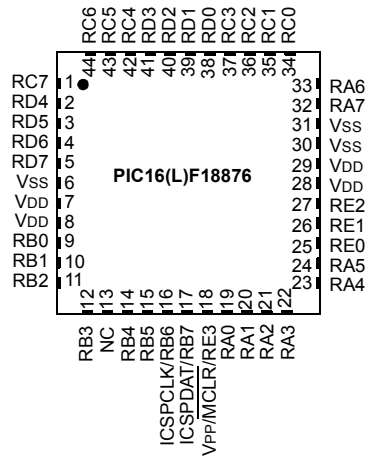

- Note 1:** See [Table 3](#) for location of all peripheral functions.
- Note 2:** All VDD and all Vss pins must be connected at the circuit board level. Allowing one or more Vss or VDD pins to float may result in degraded electrical performance or non-functionality.
- Note 3:** The bottom pad of the QFN/UQFN package should be connected to Vss at the circuit board level.

PIN ALLOCATION TABLES

TABLE 2: 28-PIN ALLOCATION TABLE (PIC16(L)F18856)

IO	28-Pin SPDIP/SOIC/SSOP		ADC	Voltage Reference	DAC	Comparators	Zero-Cross Detect	MSSP (SPI/I ² C)	EUSART	DSM	Timers/SMT	CCP and PWM	CWG	CLC	NCO
	28-Pin (U)QFN														
RA0	2	27	ANA0	—	—	C1IN0- C2IN0-	—	—	—	—	—	—	—	CLCIN0 ⁽¹⁾	—
RA1	3	28	ANA1	—	—	C1IN1- C2IN1-	—	—	—	—	—	—	—	CLCIN1 ⁽¹⁾	—
RA2	4	1	ANA2	VREF-	DAC1OUT1	C1IN0+ C2IN0+	—	—	—	—	—	—	—	—	—
RA3	5	2	ANA3	VREF+	—	C1IN1+	—	—	—	MDCARL ⁽¹⁾	—	—	—	—	—
RA4	6	3	ANA4	—	—	—	—	—	—	MDCARH ⁽¹⁾	T0CKI ⁽¹⁾	CCP5 ⁽¹⁾	—	—	—
RA5	7	4	ANA5	—	—	—	—	SS1 ⁽¹⁾	—	MDSRC ⁽¹⁾	—	—	—	—	—
RA6	10	7	ANA6	—	—	—	—	—	—	—	—	—	—	—	—
RA7	9	6	ANA7	—	—	—	—	—	—	—	—	—	—	—	—
RB0	21	18	ANB0	—	—	C2IN1+	ZCD	SS2 ⁽¹⁾	—	—	—	CCP4 ⁽¹⁾	CWG1IN ⁽¹⁾	—	—
RB1	22	19	ANB1	—	—	C1IN3- C2IN3-	—	SCL2 ^(3,4) SCK2 ⁽¹⁾	—	—	—	—	CWG2IN ⁽¹⁾	—	—
RB2	23	20	ANB2	—	—	—	—	SDA2 ^(3,4) SDI2 ⁽¹⁾	—	—	—	—	CWG3IN ⁽¹⁾	—	—
RB3	24	21	ANB3	—	—	C1IN2- C2IN2-	—	—	—	—	—	—	—	—	—
RB4	25	22	ANB4 ADCACT ⁽¹⁾	—	—	—	—	—	—	—	T5G ⁽¹⁾ SMTWIN2 ⁽¹⁾	—	—	—	—

- Note** 1: This is a PPS remappable input signal. The input function may be moved from the default location shown to one of several other PORTX pins. Refer to [Table 13-1](#) for used for this signal.
- 2: All output signals shown in this row are PPS remappable. These signals may be mapped to output onto one of several PORTX pin options as described in [Table 13-1](#).
- 3: This is a bidirectional signal. For normal module operation, the firmware should map this signal to the same pin in both the PPS input and PPS output registers.
- 4: These pins are configured for I²C logic levels.; The SCLx/SDAx signals may be assigned to any of the RB1/RB2/RC3/RC4 pins. PPS assignments to the other pins logic levels will be standard TTL/ST, as selected by the INLVL register, instead of the I²C specific or SMBus input buffer thresholds.

TABLE 2: 28-PIN ALLOCATION TABLE (PIC16(L)F18856) (CONTINUED)

I/O	28-Pin SPDIP/SOIC/SSOP		ADC	Voltage Reference	DAC	Comparators	Zero-Cross Detect	MSSP (SPI/I ² C)	EUSART	DSM	Timers/SMT	CCP and PWM	CWG	CLC	NCO
	28-Pin (U)	QFN													
RB5	26	23	ANB5	—	—	—	—	—	—	—	T1G ⁽¹⁾ SMTSIG2 ⁽¹⁾	CCP3 ⁽¹⁾	—	—	—
RB6	27	24	ANB6	—	—	—	—	—	—	—	—	—	—	CLCIN2 ⁽¹⁾	—
RB7	28	25	ANB7	—	DAC1OUT2	—	—	—	—	—	T6IN ⁽¹⁾	—	—	CLCIN3 ⁽¹⁾	—
RC0	11	8	ANC0	—	—	—	—	—	—	—	T1CKI ⁽¹⁾ T3CKI ⁽¹⁾ T3G ⁽¹⁾ SMTWIN1 ⁽¹⁾	—	—	—	—
RC1	12	9	ANC1	—	—	—	—	—	—	—	SMTSIG1 ⁽¹⁾	CCP2 ⁽¹⁾	—	—	—
RC2	13	10	ANC2	—	—	—	—	—	—	—	T5CKI ⁽¹⁾	CCP1 ⁽¹⁾	—	—	—
RC3	14	11	ANC3	—	—	—	—	SCL1 ^(3,4) SCK1 ⁽¹⁾	—	—	T2IN ⁽¹⁾	—	—	—	—
RC4	15	12	ANC4	—	—	—	—	SDA1 ^(3,4) SDI1 ⁽¹⁾	—	—	—	—	—	—	—
RC5	16	13	ANC5	—	—	—	—	—	—	—	T4IN ⁽¹⁾	—	—	—	—
RC6	17	14	ANC6	—	—	—	—	—	CK ⁽³⁾	—	—	—	—	—	—
RC7	18	15	ANC7	—	—	—	—	—	RX ⁽¹⁾ DT ⁽³⁾	—	—	—	—	—	—
RE3	1	26	—	—	—	—	—	—	—	—	—	—	—	—	—
VDD	20	17	—	—	—	—	—	—	—	—	—	—	—	—	—
VSS	8, 19	5, 16	—	—	—	—	—	—	—	—	—	—	—	—	—

- Note** 1: This is a PPS remappable input signal. The input function may be moved from the default location shown to one of several other PORTX pins. Refer to [Table 13-1](#) for used for this signal.
- 2: All output signals shown in this row are PPS remappable. These signals may be mapped to output onto one of several PORTX pin options as described in [Table 13-1](#).
- 3: This is a bidirectional signal. For normal module operation, the firmware should map this signal to the same pin in both the PPS input and PPS output registers.
- 4: These pins are configured for I²C logic levels.; The SCLx/SDAx signals may be assigned to any of the RB1/RB2/RC3/RC4 pins. PPS assignments to the other pins logic levels will be standard TTL/ST, as selected by the INLVL register, instead of the I²C specific or SMBus input buffer thresholds.

TABLE 2: 28-PIN ALLOCATION TABLE (PIC16(L)F18856) (CONTINUED)

I/O	28-Pin SPDIP/SOIC/SSOP	28-Pin (U)QFN	ADC	Voltage Reference	DAC	Comparators	Zero-Cross Detect	MSSP (SPI/I ² C)	EUSART	DSM	Timers/SMT	CCP and PWM	CWG	CLC	NCO
OUT ⁽²⁾	—	—	ADGRDA ADGRDB	—	—	C1OUT C2OUT	—	SDO1 SCK1 SDO2 SCK2	TX/ CK ⁽³⁾ DT ⁽³⁾	DSM	TMR0	CCP1 CCP2 CCP3 CCP4 CCP5 PWM6OUT PWM7OUT	CWG1A CWG1B CWG1C CWG1D CWG2A CWG2B CWG2C CWG2D CWG3A CWG3B CWG3C CWG3D	CLC1OUT CLC2OUT CLC3OUT CLC4OUT	NO

- Note**
- 1: This is a PPS remappable input signal. The input function may be moved from the default location shown to one of several other PORTX pins. Refer to [Table 13-1](#) for used for this signal.
 - 2: All output signals shown in this row are PPS remappable. These signals may be mapped to output onto one of several PORTX pin options as described in [Table 13-1](#).
 - 3: This is a bidirectional signal. For normal module operation, the firmware should map this signal to the same pin in both the PPS input and PPS output registers.
 - 4: These pins are configured for I²C logic levels.; The SCLx/SDAx signals may be assigned to any of the RB1/RB2/RC3/RC4 pins. PPS assignments to the other pins logic levels will be standard TTL/ST, as selected by the INLVL register, instead of the I²C specific or SMBus input buffer thresholds.

TABLE 3: 40/44-PIN ALLOCATION TABLE (PIC16(L)F18876)

I/O	40-Pin PDIP	40-Pin UQFN	44-Pin QFN	44-Pin TQFP	ADC	Voltage Reference	DAC	Comparators	Zero-Cross Detect	MSSP (SPI/I ² C)	EUSART	DSM	Timers/SMT	CCP and PWM	CWG	CLC
RA0	2	17	19	19	ANA0	—	—	C1IN0- C2IN0-	—	—	—	—	—	—	—	CLCIN0 ⁽¹⁾
RA1	3	18	20	20	ANA1	—	—	C1IN1- C2IN1-	—	—	—	—	—	—	—	CLCIN1 ⁽¹⁾
RA2	4	19	21	21	ANA2	VREF-	DAC1OUT1	C1IN0+ C2IN0+	—	—	—	—	—	—	—	—
RA3	5	20	22	22	ANA3	VREF+	—	C1IN1+	—	—	—	MDCARL ⁽¹⁾	—	—	—	—
RA4	6	21	23	23	ANA4	—	—	—	—	—	—	MDCARH ⁽¹⁾	T0CKI ⁽¹⁾	CCP5 ⁽¹⁾	—	—
RA5	7	22	24	24	ANA5	—	—	—	—	SS1 ⁽¹⁾	—	MDSRC ⁽¹⁾	—	—	—	—
RA6	14	29	33	31	ANA6	—	—	—	—	—	—	—	—	—	—	—
RA7	13	28	32	30	ANA7	—	—	—	—	—	—	—	—	—	—	—
RB0	33	8	9	8	ANB0	—	—	C2IN1+	ZCD	SS2 ⁽¹⁾	—	—	—	CCP4 ⁽¹⁾	CWG1IN ⁽¹⁾	—
RB1	34	9	10	9	ANB1	—	—	C1IN3- C2IN3-	—	SCL2 ^(3,4) SCK2 ⁽¹⁾	—	—	—	—	CWG2IN ⁽¹⁾	—
RB2	35	10	11	10	ANB2	—	—	—	—	SDA2 ^(3,4) SDI2 ⁽¹⁾	—	—	—	—	CWG3IN ⁽¹⁾	—
RB3	36	11	12	11	ANB3	—	—	C1IN2- C2IN2-	—	—	—	—	—	—	—	—
RB4	37	12	14	14	ANB4 ADCACT ⁽¹⁾	—	—	—	—	—	—	—	T5G ⁽¹⁾ SMTWIN2 ⁽¹⁾	—	—	—
RB5	38	13	15	15	ANB5	—	—	—	—	—	—	—	T1G ⁽¹⁾ SMTSIG2 ⁽¹⁾	CCP3(1)	—	—
RB6	39	14	16	16	ANB6	—	—	—	—	—	—	—	—	—	—	CLCIN2 ⁽¹⁾
RB7	40	15	17	17	ANB7	—	DAC1OUT2	—	—	—	—	—	T6IN ⁽¹⁾	—	—	CLCIN3 ⁽¹⁾

- Note** 1: This is a PPS remappable input signal. The input function may be moved from the default location shown to one of several other PORTx pins. Refer to [Table 13-1](#) for used for this signal.
- 2: All output signals shown in this row are PPS remappable. These signals may be mapped to output onto one of several PORTx pin options as described in [Table 13-1](#).
- 3: This is a bidirectional signal. For normal module operation, the firmware should map this signal to the same pin in both the PPS input and PPS output registers.
- 4: These pins are configured for I²C logic levels.; The SCLx/SDAx signals may be assigned to any of the RB1/RB2/RC3/RC4 pins. PPS assignments to the other pins logic levels will be standard TTL/ST, as selected by the INLVL register, instead of the I²C specific or SMBus input buffer thresholds.

TABLE 3: 40/44-PIN ALLOCATION TABLE (PIC16(L)F18876) (CONTINUED)

I/O	40-Pin PDIP	40-Pin UQFN	44-Pin QFN	44-Pin TQFP	ADC	Voltage Reference	DAC	Comparators	Zero-Cross Detect	MSSP (SPI/I ² C)	EUSART	DSM	Timers/SMT	CCP and PWM	CWG	CLC
RC0	15	30	34	32	ANC0	—	—	—	—	—	—	—	T1CKI ⁽¹⁾ T3CKI ⁽¹⁾ T3G ⁽¹⁾ SMTWIN1 ⁽¹⁾	—	—	—
RC1	16	31	35	35	ANC1	—	—	—	—	—	—	—	SMTSIG1 ⁽¹⁾	CCP2 ⁽¹⁾	—	—
RC2	17	32	36	36	ANC2	—	—	—	—	—	—	—	T5CKI ⁽¹⁾	CCP1 ⁽¹⁾	—	—
RC3	18	33	37	37	ANC3	—	—	—	—	SCL1 ^(3,4) SCK1 ⁽¹⁾	—	—	T2IN ⁽¹⁾	—	—	—
RC4	23	38	42	42	ANC4	—	—	—	—	SDA1 ^(3,4) SDI1 ⁽¹⁾	—	—	—	—	—	—
RC5	24	39	43	43	ANC5	—	—	—	—	—	—	—	T4IN ⁽¹⁾	—	—	—
RC6	25	40	44	44	ANC6	—	—	—	—	—	CK ⁽³⁾	—	—	—	—	—
RC7	26	1	1	1	ANC7	—	—	—	—	—	RX ⁽¹⁾ DT ⁽³⁾	—	—	—	—	—
RD0	19	34	38	38	AND0	—	—	—	—	—	—	—	—	—	—	—
RD1	20	35	39	39	AND1	—	—	—	—	—	—	—	—	—	—	—
RD2	21	36	40	40	AND2	—	—	—	—	—	—	—	—	—	—	—
RD3	22	37	41	41	AND3	—	—	—	—	—	—	—	—	—	—	—
RD4	27	2	2	2	AND4	—	—	—	—	—	—	—	—	—	—	—
RD5	28	3	3	3	AND5	—	—	—	—	—	—	—	—	—	—	—
RD6	29	4	4	4	AND6	—	—	—	—	—	—	—	—	—	—	—
RD7	30	5	5	5	AND7	—	—	—	—	—	—	—	—	—	—	—
RE0	8	23	25	25	ANE0	—	—	—	—	—	—	—	—	—	—	—
RE1	9	24	26	26	ANE1	—	—	—	—	—	—	—	—	—	—	—
RE2	10	25	27	27	ANE2	—	—	—	—	—	—	—	—	—	—	—

- Note** 1: This is a PPS remappable input signal. The input function may be moved from the default location shown to one of several other PORTx pins. Refer to [Table 13-1](#) for used for this signal.
- 2: All output signals shown in this row are PPS remappable. These signals may be mapped to output onto one of several PORTx pin options as described in [Table 13-1](#).
- 3: This is a bidirectional signal. For normal module operation, the firmware should map this signal to the same pin in both the PPS input and PPS output registers.
- 4: These pins are configured for I²C logic levels.; The SCLx/SDAx signals may be assigned to any of the RB1/RB2/RC3/RC4 pins. PPS assignments to the other pins logic levels will be standard TTL/ST, as selected by the INLVL register, instead of the I²C specific or SMBus input buffer thresholds.

TABLE 3: 40/44-PIN ALLOCATION TABLE (PIC16(L)F18876) (CONTINUED)

I/O	40-Pin PDIP	40-Pin UQFN	44-Pin QFN	44-Pin TQFP	ADC	Voltage Reference	DAC	Comparators	Zero-Cross Detect	MSSP (SPI/I ² C)	EUSART	DSM	Timers/SMT	CCP and PWM	CWG	CLC
RE3	1	16	18	18	—	—	—	—	—	—	—	—	—	—	—	—
VDD	11, 32	7, 26	8, 28	7, 28	—	—	—	—	—	—	—	—	—	—	—	—
VSS	12, 31	6, 27	6, 31, 30	6, 29	—	—	—	—	—	—	—	—	—	—	—	—
OUT ⁽²⁾	—	—	—	—	ADGRDA ADGRDB	—	—	C1OUT C2OUT	—	SDO1 SCK1 SDO2 SCK2	TX/ CK ⁽³⁾ DT ⁽³⁾	DSM	TMR0	CCP1 CCP2 CCP3 CCP4 CCP5 PWM6OUT PWM7OUT	CWG1A CWG1B CWG1C CWG1D CWG2A CWG2B CWG2C CWG2D CWG3A CWG3B CWG3C CWG3D	CLC1OUT CLC2OUT CLC3OUT CLC4OUT

- Note** 1: This is a PPS remappable input signal. The input function may be moved from the default location shown to one of several other PORTx pins. Refer to [Table 13-1](#) for used for this signal.
- 2: All output signals shown in this row are PPS remappable. These signals may be mapped to output onto one of several PORTx pin options as described in [Table 13-1](#).
- 3: This is a bidirectional signal. For normal module operation, the firmware should map this signal to the same pin in both the PPS input and PPS output registers.
- 4: These pins are configured for I²C logic levels.; The SCLx/SDAx signals may be assigned to any of the RB1/RB2/RC3/RC4 pins. PPS assignments to the other pins logic levels will be standard TTL/ST, as selected by the INLVL register, instead of the I²C specific or SMBus input buffer thresholds.

PIC16(L)F18856/76

Table of Contents

1.0	Device Overview	16
2.0	Enhanced Mid-Range CPU	33
3.0	Memory Organization	35
4.0	Device Configuration	92
5.0	Resets	101
6.0	Oscillator Module (with Fail-Safe Clock Monitor)	110
7.0	Interrupts	129
8.0	Power-Saving Operation Modes	155
9.0	Windowed Watchdog Timer (WWDT)	162
10.0	Nonvolatile Memory (NVM) Control.....	170
11.0	Cyclic Redundancy Check (CRC) Module	188
12.0	I/O Ports	200
13.0	Peripheral Pin Select (PPS) Module	243
14.0	Peripheral Module Disable	253
15.0	Interrupt-On-Change	260
16.0	Fixed Voltage Reference (FVR)	268
17.0	Temperature Indicator Module	271
18.0	Comparator Module.....	273
19.0	Pulse-Width Modulation (PWM)	283
20.0	Complementary Waveform Generator (CWG) Module	290
21.0	Zero-Cross Detection (ZCD) Module.....	314
22.0	Configurable Logic Cell (CLC).....	320
23.0	Analog-to-Digital Converter With Computation (ADC2) Module.....	337
24.0	Numerically Controlled Oscillator (NCO) Module	376
25.0	5-Bit Digital-to-Analog Converter (DAC1) Module	386
26.0	Data Signal Modulator (DSM) Module.....	391
27.0	Timer0 Module	404
28.0	Timer1/3/5 Module with Gate Control.....	410
29.0	Timer2/4/6 Module	424
30.0	Capture/Compare/PWM Modules	445
31.0	Master Synchronous Serial Port (MSSP) Modules	458
32.0	Signal Measurement Timer (SMT)	509
33.0	Enhanced Universal Synchronous Asynchronous Receiver Transmitter (EUSART)	554
34.0	Reference Clock Output Module	582
35.0	In-Circuit Serial Programming™ (ICSP™)	586
36.0	Instruction Set Summary	588
37.0	Electrical Specifications.....	602
38.0	DC and AC Characteristics Graphs and Charts	632
39.0	Development Support.....	648
40.0	Packaging Information.....	652
	Data Sheet Revision History	678

TO OUR VALUED CUSTOMERS

It is our intention to provide our valued customers with the best documentation possible to ensure successful use of your Microchip products. To this end, we will continue to improve our publications to better suit your needs. Our publications will be refined and enhanced as new volumes and updates are introduced.

If you have any questions or comments regarding this publication, please contact the Marketing Communications Department via E-mail at docerrors@microchip.com. We welcome your feedback.

Most Current Data Sheet

To obtain the most up-to-date version of this data sheet, please register at our Worldwide Website at:

<http://www.microchip.com>

You can determine the version of a data sheet by examining its literature number found on the bottom outside corner of any page. The last character of the literature number is the version number, (e.g., DS30000000A is version A of document DS30000000).

Errata

An errata sheet, describing minor operational differences from the data sheet and recommended workarounds, may exist for current devices. As device/documentation issues become known to us, we will publish an errata sheet. The errata will specify the revision of silicon and revision of document to which it applies.

To determine if an errata sheet exists for a particular device, please check with one of the following:

- Microchip's Worldwide Website; <http://www.microchip.com>
- Your local Microchip sales office (see last page)

When contacting a sales office, please specify which device, revision of silicon and data sheet (include literature number) you are using.

Customer Notification System

Register on our website at www.microchip.com to receive the most current information on all of our products.

PIC16(L)F18856/76

1.0 DEVICE OVERVIEW

The PIC16(L)F18856/76 are described within this data sheet. The PIC16(L)F18856 devices are available in 28-pin SPDIP, SSOP, SOIC, and UQFN packages. The PIC16(L)F18876 devices are available in 40-pin PDIP and UQFN and 44-pin TQFP and QFN packages.

Figure 1-1 shows a block diagram of the PIC16(L)F18856/76 devices. Table 1-2 and Table 1-3 show the pinout descriptions.

Reference Table 1-1 for peripherals available per device.

TABLE 1-1: DEVICE PERIPHERAL SUMMARY

Peripheral	PIC16(L)F18856	PIC16(L)F18856	
Analog-to-Digital Converter with Computation (ADC ²)	•	•	
Cyclic Redundancy Check (CRC)	•	•	
Digital-to-Analog Converter (DAC)	•	•	
Fixed Voltage Reference (FVR)	•	•	
Enhanced Universal Synchronous/Asynchronous Receiver/Transmitter (EUSART1)	•	•	
Digital Signal Modulator (DSM)	•	•	
Numerically Controlled Oscillator (NCO1)	•	•	
Temperature Indicator	•	•	
Zero-Cross Detect (ZCD)	•	•	
Capture/Compare/PWM (CCP/ECCP) Modules			
	CCP1	•	•
	CCP2	•	•
	CCP3	•	•
	CCP4	•	•
	CCP5	•	•
Comparators			
	C1	•	•
	C2	•	•
Configurable Logic Cell (CLC)			
	CLC1	•	•
	CLC2	•	•
	CLC3	•	•
	CLC4	•	•
Complementary Waveform Generator (CWG)			
	CWG1	•	•
	CWG2	•	•
	CWG3	•	•
Master Synchronous Serial Ports			
	MSSP1	•	•
	MSSP2	•	•
Pulse-Width Modulator (PWM)			
	PWM6	•	•
	PWM7	•	•
Signal Measure Timer (SMT)			
	SMT1	•	•
	SMT2	•	•
Timers			
	Timer0	•	•
	Timer1	•	•
	Timer2	•	•
	Timer3	•	•
	Timer4	•	•
	Timer5	•	•
	Timer6	•	•

PIC16(L)F18856/76

1.1 Register and Bit naming conventions

1.1.1 REGISTER NAMES

When there are multiple instances of the same peripheral in a device, the peripheral control registers will be depicted as the concatenation of a peripheral identifier, peripheral instance, and control identifier. The control registers section will show just one instance of all the register names with an 'x' in the place of the peripheral instance number. This naming convention may also be applied to peripherals when there is only one instance of that peripheral in the device to maintain compatibility with other devices in the family that contain more than one.

1.1.2 BIT NAMES

There are two variants for bit names:

- Short name: Bit function abbreviation
- Long name: Peripheral abbreviation + short name

1.1.2.1 Short Bit Names

Short bit names are an abbreviation for the bit function. For example, some peripherals are enabled with the EN bit. The bit names shown in the registers are the short name variant.

Short bit names are useful when accessing bits in C programs. The general format for accessing bits by the short name is *RegisterNamebits.ShortName*. For example, the enable bit, EN, in the COG1CON0 register can be set in C programs with the instruction `COG1CON0bits.EN = 1`.

Short names are generally not useful in assembly programs because the same name may be used by different peripherals in different bit positions. When this occurs, during the include file generation, all instances of that short bit name are appended with an underscore plus the name of the register in which the bit resides to avoid naming contentions.

1.1.2.2 Long Bit Names

Long bit names are constructed by adding a peripheral abbreviation prefix to the short name. The prefix is unique to the peripheral thereby making every long bit name unique. The long bit name for the COG1 enable bit is the COG1 prefix, G1, appended with the enable bit short name, EN, resulting in the unique bit name G1EN.

Long bit names are useful in both C and assembly programs. For example, in C the COG1CON0 enable bit can be set with the `G1EN = 1` instruction. In assembly, this bit can be set with the `BSF COG1CON0,G1EN` instruction.

1.1.2.3 Bit Fields

Bit fields are two or more adjacent bits in the same register. Bit fields adhere only to the short bit naming convention. For example, the three Least Significant bits of the COG1CON0 register contain the mode control bits. The short name for this field is MD. There is no long bit name variant. Bit field access is only possible in C programs. The following example demonstrates a C program instruction for setting the COG1 to the Push-Pull mode:

```
COG1CON0bits.MD = 0x5;
```

Individual bits in a bit field can also be accessed with long and short bit names. Each bit is the field name appended with the number of the bit position within the field. For example, the Most Significant mode bit has the short bit name MD2 and the long bit name is G1MD2. The following two examples demonstrate assembly program sequences for setting the COG1 to Push-Pull mode:

Example 1:

```
MOVLW ~(1<<G1MD1)
ANDWF COG1CON0,F
MOVLW 1<<G1MD2 | 1<<G1MD0
IORWF COG1CON0,F
```

Example 2:

```
BSF COG1CON0,G1MD2
BCF COG1CON0,G1MD1
BSF COG1CON0,G1MD0
```

1.1.3 REGISTER AND BIT NAMING EXCEPTIONS

1.1.3.1 Status, Interrupt, and Mirror Bits

Status, interrupt enables, interrupt flags, and mirror bits are contained in registers that span more than one peripheral. In these cases, the bit name shown is unique so there is no prefix or short name variant.

1.1.3.2 Legacy Peripherals

There are some peripherals that do not strictly adhere to these naming conventions. Peripherals that have existed for many years and are present in almost every device are the exceptions. These exceptions were necessary to limit the adverse impact of the new conventions on legacy code. Peripherals that do adhere to the new convention will include a table in the registers section indicating the long name prefix for each peripheral instance. Peripherals that fall into the exception category will not have this table. These peripherals include, but are not limited to, the following:

- EUSART
- MSSP

FIGURE 1-1: PIC16(L)F18856/76 BLOCK DIAGRAM

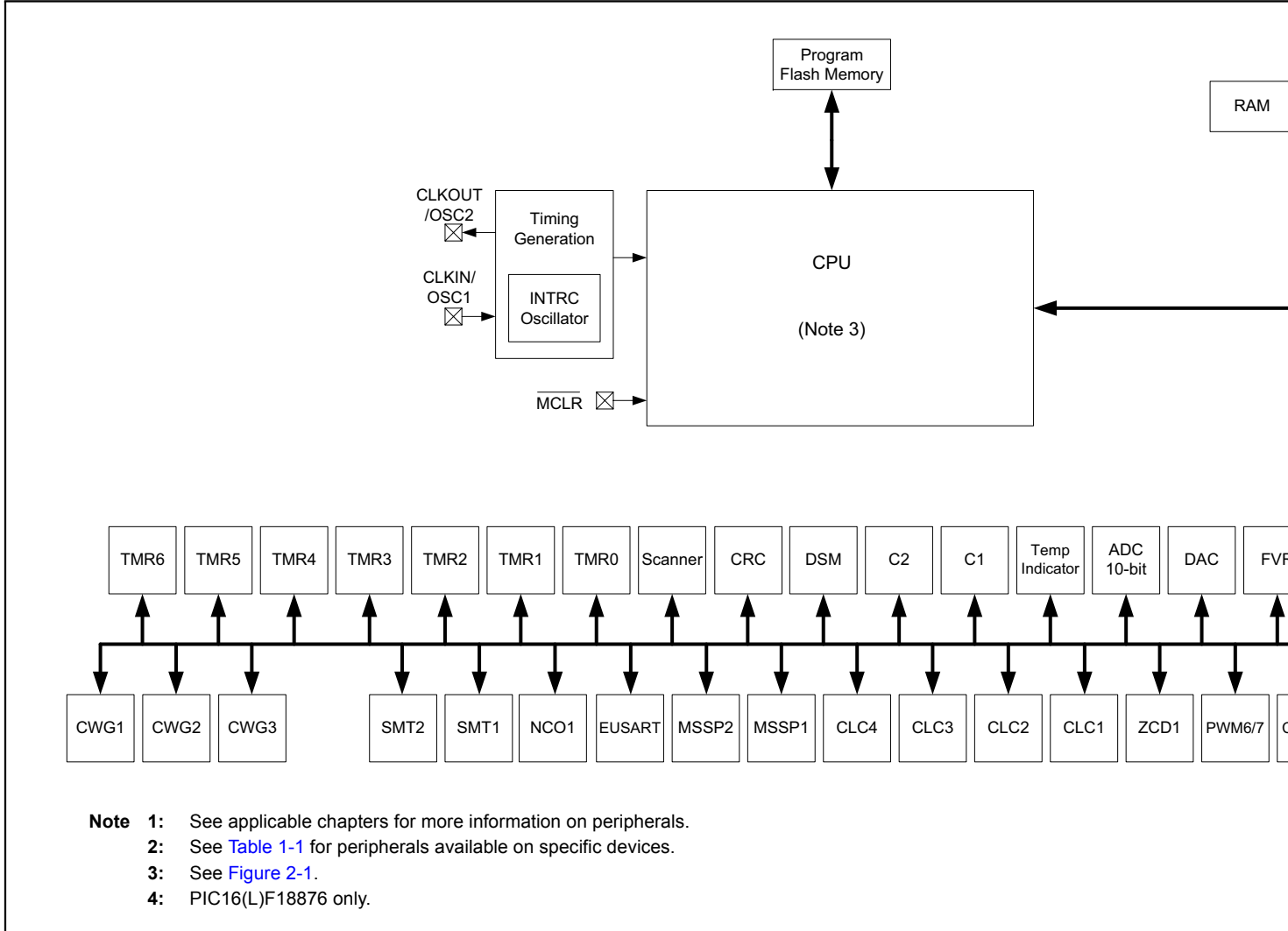

- Note**
- 1: See applicable chapters for more information on peripherals.
 - 2: See [Table 1-1](#) for peripherals available on specific devices.
 - 3: See [Figure 2-1](#).
 - 4: PIC16(L)F18876 only.

PIC16(L)F18856/76

TABLE 1-2: PIC16F18856 PINOUT DESCRIPTION

Name	Function	Input Type	Output Type	Description
RA0/ANA0/C1IN0-/C2IN0-/CLCIN0 ⁽¹⁾ /IOCA0	RA0	TTL/ST	CMOS/OD	General purpose I/O.
	ANA0	AN	—	ADC Channel A0 input.
	C1IN0-	AN	—	Comparator negative input.
	C2IN0-	AN	—	Comparator negative input.
	CLCIN0 ⁽¹⁾	TTL/ST	—	Configurable Logic Cell source input.
	IOCA0	TTL/ST	—	Interrupt-on-change input.
RA1/ANA1/C1IN1-/C2IN1-/CLCIN1 ⁽¹⁾ /IOCA1	RA1	TTL/ST	CMOS/OD	General purpose I/O.
	ANA1	AN	—	ADC Channel A1 input.
	C1IN1-	AN	—	Comparator negative input.
	C2IN1-	AN	—	Comparator negative input.
	CLCIN1 ⁽¹⁾	TTL/ST	—	Configurable Logic Cell source input.
	IOCA1	TTL/ST	—	Interrupt-on-change input.
RA2/ANA2/C1IN0+/C2IN0+/VREF-/DAC1OUT1/IOCA2	RA2	TTL/ST	CMOS/OD	General purpose I/O.
	ANA2	AN	—	ADC Channel A2 input.
	C1IN0+	AN	—	Comparator positive input.
	C2IN0+	AN	—	Comparator positive input.
	VREF-	AN	—	External ADC and/or DAC negative reference input.
	DAC1OUT1	—	AN	Digital-to-Analog Converter output.
	IOCA2	TTL/ST	—	Interrupt-on-change input.
RA3/ANA3/C1IN1+/VREF+/MDCARL ⁽¹⁾ /IOCA3	RA3	TTL/ST	CMOS/OD	General purpose I/O.
	ANA3	AN	—	ADC Channel A3 input.
	C1IN1+	AN	—	Comparator positive input.
	VREF+	AN	—	External ADC and/or DAC positive reference input.
	MDCARL ⁽¹⁾	TTL/ST	—	Modular Carrier input 1.
	IOCA3	TTL/ST	—	Interrupt-on-change input.
RA4/ANA4/MDCARH ⁽¹⁾ /T0CKI ⁽¹⁾ /CCP5 ⁽¹⁾ /IOCA4	RA4	TTL/ST	CMOS/OD	General purpose I/O.
	ANA4	AN	—	ADC Channel A4 input.
	MDCARH ⁽¹⁾	TTL/ST	—	Modular Carrier input 2.
	T0CKI ⁽¹⁾	TTL/ST	—	Timer0 clock input.
	CCP5 ⁽¹⁾	TTL/ST	CMOS/OD	Capture/compare/PWM5 (default input location for capture function).
	IOCA4	TTL/ST	—	Interrupt-on-change input.

Legend: AN = Analog input or output CMOS = CMOS compatible input or output OD = Open-Drain
TTL = TTL compatible input ST = Schmitt Trigger input with CMOS levels I²C = Schmitt Trigger input with I²C
HV = High Voltage XTAL = Crystal levels

- Note**
- 1: This is a PPS remappable input signal. The input function may be moved from the default location shown to one of several other PORTx pins. Refer to [Table 13-1](#) for details on which PORT pins may be used for this signal.
 - 2: All output signals shown in this row are PPS remappable. These signals may be mapped to output onto one of several PORTx pin options as described in [Table 13-3](#).
 - 3: This is a bidirectional signal. For normal module operation, the firmware should map this signal to the same pin in both the PPS input and PPS output registers.
 - 4: These pins are configured for I²C logic levels. The SCLx/SDAx signals may be assigned to any of the RB1/RB2/RC3/RC4 pins. PPS assignments to the other pins (e.g., RA5) will operate, but input logic levels will be standard TTL/ST, as selected by the INLVL register, instead of the I²C specific or SMBus input buffer thresholds.

PIC16(L)F18856/76

TABLE 1-2: PIC16F18856 PINOUT DESCRIPTION (CONTINUED)

Name	Function	Input Type	Output Type	Description
RA5/ANA5/SS1 ⁽¹⁾ /MDSRC ⁽¹⁾ /IOCA5	RA5	TTL/ST	CMOS/OD	General purpose I/O.
	ANA5	AN	—	ADC Channel A5 input.
	SS1 ⁽¹⁾	TTL/ST	—	MSSP1 SPI slave select input.
	MDSRC ⁽¹⁾	TTL/ST	—	Modulator Source input.
	IOCA5	TTL/ST	—	Interrupt-on-change input.
RA6/ANA6/OSC2/CLKOUT/IOCA6	RA6	TTL/ST	CMOS/OD	General purpose I/O.
	ANA6	AN	—	ADC Channel A6 input.
	OSC2	—	XTAL	External Crystal/Resonator (LP, XT, HS modes) driver output.
	CLKOUT	—	CMOS/OD	Fosc/4 digital output (in non-crystal/resonator modes).
	IOCA6	TTL/ST	—	Interrupt-on-change input.
RA7/ANA7/OSC1/CLKIN/IOCA7	RA7	TTL/ST	CMOS/OD	General purpose I/O.
	ANA7	AN	—	ADC Channel A7 input.
	OSC1	XTAL	—	External Crystal/Resonator (LP, XT, HS modes) driver input.
	CLKIN	TTL/ST	—	External digital clock input.
	IOCA7	TTL/ST	—	Interrupt-on-change input.
RB0/ANB0/C2IN1+/ZCD/SS2 ⁽¹⁾ /CCP4 ⁽¹⁾ /CWG1IN ⁽¹⁾ /INT ⁽¹⁾ /IOCB0	RB0	TTL/ST	CMOS/OD	General purpose I/O.
	ANB0	AN	—	ADC Channel B0 input.
	C2IN1+	AN	—	Comparator positive input.
	ZCD	AN	AN	Zero-cross detect input pin (with constant current sink/source).
	SS2 ⁽¹⁾	TTL/ST	—	MSSP2 SPI slave select input.
	CCP4 ⁽¹⁾	TTL/ST	CMOS/OD	Capture/compare/PWM4 (default input location for capture function).
	CWG1IN ⁽¹⁾	TTL/ST	—	Complementary Waveform Generator 1 input.
	INT ⁽¹⁾	TTL/ST	—	External interrupt request input.
	IOCB0	TTL/ST	—	Interrupt-on-change input.
RB1/ANB1/C1IN3-/C2IN3-/SCL2 ^(3,4) /SCK2 ⁽¹⁾ /CWG2IN ⁽¹⁾ /IOCB1	RB1	TTL/ST	CMOS/OD	General purpose I/O.
	ANB1	AN	—	ADC Channel B1 input.
	C1IN3-	AN	—	Comparator negative input.
	C2IN3-	AN	—	Comparator negative input.
	SCL2 ^(3,4)	I ² C/ SMBus	OD	MSSP2 I ² C clock input/output.
	SCK2 ⁽¹⁾	TTL/ST	CMOS/OD	MSSP2 SPI serial clock (default input location, SCK2 is a PPS remappable input and output).
	CWG2IN ⁽¹⁾	TTL/ST	—	Complementary Waveform Generator 2 input.
	IOCB1	TTL/ST	—	Interrupt-on-change input.

Legend: AN = Analog input or output CMOS = CMOS compatible input or output OD = Open-Drain
TTL = TTL compatible input ST = Schmitt Trigger input with CMOS levels I²C = Schmitt Trigger input with I²C
HV = High Voltage XTAL = Crystal levels

- Note**
- 1: This is a PPS remappable input signal. The input function may be moved from the default location shown to one of several other PORTx pins. Refer to [Table 13-1](#) for details on which PORT pins may be used for this signal.
 - 2: All output signals shown in this row are PPS remappable. These signals may be mapped to output onto one of several PORTx pin options as described in [Table 13-3](#).
 - 3: This is a bidirectional signal. For normal module operation, the firmware should map this signal to the same pin in both the PPS input and PPS output registers.
 - 4: These pins are configured for I²C logic levels. The SCLx/SDAx signals may be assigned to any of the RB1/RB2/RC3/RC4 pins. PPS assignments to the other pins (e.g., RA5) will operate, but input logic levels will be standard TTL/ST, as selected by the INLVL register, instead of the I²C specific or SMBus input buffer thresholds.

PIC16(L)F18856/76

TABLE 1-2: PIC16F18856 PINOUT DESCRIPTION (CONTINUED)

Name	Function	Input Type	Output Type	Description
RB2/ANB2/SDA2 ^(3,4) /SDI2 ⁽¹⁾ / CWG3IN ⁽¹⁾ /IOCB2	RB2	TTL/ST	CMOS/OD	General purpose I/O.
	ANB2	AN	—	ADC Channel B2 input.
	SDA2 ^(3,4)	I ² C/ SMBus	OD	MSSP2 I ² C serial data input/output.
	SDI2 ⁽¹⁾	TTL/ST	—	MSSP2 SPI serial data input.
	CWG3IN ⁽¹⁾	TTL/ST	—	Complementary Waveform Generator 3 input.
	IOCB2	TTL/ST	—	Interrupt-on-change input.
RB3/ANB3/C1IN2-/C2IN2-/IOCB3	RB3	TTL/ST	CMOS/OD	General purpose I/O.
	ANB3	AN	—	ADC Channel B3 input.
	C1IN2-	AN	—	Comparator negative input.
	C2IN2-	AN	—	Comparator negative input.
	IOCB3	TTL/ST	—	Interrupt-on-change input.
RB4/ANB4/ADCACT ⁽¹⁾ /T5G ⁽¹⁾ / SMTWIN2 ⁽¹⁾ /IOCB4	RB4	TTL/ST	CMOS/OD	General purpose I/O.
	ANB4	AN	—	ADC Channel B4 input.
	ADCACT ⁽¹⁾	TTL/ST	—	ADC Auto-Conversion Trigger input.
	T5G ⁽¹⁾	TTL/ST	—	Timer5 gate input.
	SMTWIN2 ⁽¹⁾	TTL/ST	—	Signal Measurement Timer 2 (SMT2) window input.
	IOCB4	TTL/ST	—	Interrupt-on-change input.
RB5/ANB5/T1G ⁽¹⁾ /SMTSIG2 ⁽¹⁾ / CCP3 ⁽¹⁾ /IOCB5	RB5	TTL/ST	CMOS/OD	General purpose I/O.
	ANB5	AN	—	ADC Channel B5 input.
	T1G ⁽¹⁾	TTL/ST	—	Timer1 gate input.
	SMTSIG2 ⁽¹⁾	TTL/ST	—	Signal Measurement Timer 2 (SMT2) signal input.
	CCP3 ⁽¹⁾	TTL/ST	CMOS/OD	Capture/compare/PWM3 (default input location for capture function).
	IOCB5	TTL/ST	—	Interrupt-on-change input.
RB6/ANB6/CLCIN2 ⁽¹⁾ /IOCB6/ICSPCLK	RB6	TTL/ST	CMOS/OD	General purpose I/O.
	ANB6	AN	—	ADC Channel B6 input.
	CLCIN2 ⁽¹⁾	TTL/ST	—	Configurable Logic Cell source input.
	IOCB6	TTL/ST	—	Interrupt-on-change input.
	ICSPCLK	ST	—	In-Circuit Serial Programming™ and debugging clock input.

Legend: AN = Analog input or output CMOS = CMOS compatible input or output OD = Open-Drain
TTL = TTL compatible input ST = Schmitt Trigger input with CMOS levels I²C = Schmitt Trigger input with I²C
HV = High Voltage XTAL = Crystal levels

- Note**
- 1: This is a PPS remappable input signal. The input function may be moved from the default location shown to one of several other PORTx pins. Refer to [Table 13-1](#) for details on which PORT pins may be used for this signal.
 - 2: All output signals shown in this row are PPS remappable. These signals may be mapped to output onto one of several PORTx pin options as described in [Table 13-3](#).
 - 3: This is a bidirectional signal. For normal module operation, the firmware should map this signal to the same pin in both the PPS input and PPS output registers.
 - 4: These pins are configured for I²C logic levels. The SCLx/SDAx signals may be assigned to any of the RB1/RB2/RC3/RC4 pins. PPS assignments to the other pins (e.g., RA5) will operate, but input logic levels will be standard TTL/ST, as selected by the INLVL register, instead of the I²C specific or SMBus input buffer thresholds.

PIC16(L)F18856/76

TABLE 1-2: PIC16F18856 PINOUT DESCRIPTION (CONTINUED)

Name	Function	Input Type	Output Type	Description
RB7/ANB7/DAC1OUT2/T6IN ⁽¹⁾ / CLCIN3 ⁽¹⁾ /IOCB7/ICSPDAT	RB7	TTL/ST	CMOS/OD	General purpose I/O.
	ANB7	AN	—	ADC Channel B7 input.
	DAC1OUT2	—	AN	Digital-to-Analog Converter output.
	T6IN ⁽¹⁾	TTL/ST	—	Timer6 external digital clock input.
	CLCIN3 ⁽¹⁾	TTL/ST	—	Configurable Logic Cell source input.
	IOCB7	TTL/ST	—	Interrupt-on-change input.
	ICSPDAT	ST	CMOS	In-Circuit Serial Programming™ and debugging data input/output.
RC0/ANC0/T1CKI ⁽¹⁾ /T3CKI ⁽¹⁾ /T3G ⁽¹⁾ / SMTWIN1 ⁽¹⁾ /IOCC0/SOSCO	RC0	TTL/ST	CMOS/OD	General purpose I/O.
	ANC0	AN	—	ADC Channel C0 input.
	T1CKI ⁽¹⁾	TTL/ST	—	Timer1 external digital clock input.
	T3CKI ⁽¹⁾	TTL/ST	—	Timer3 external digital clock input.
	T3G ⁽¹⁾	TTL/ST	—	Timer3 gate input.
	SMTWIN1 ⁽¹⁾	TTL/ST	—	Signal Measurement Timer1 (SMT1) input.
	IOCC0	TTL/ST	—	Interrupt-on-change input.
RC1/ANC1/SMTSIG1 ⁽¹⁾ /CCP2 ⁽¹⁾ / IOCC1/SOSCI	RC1	TTL/ST	CMOS/OD	General purpose I/O.
	ANC1	AN	—	ADC Channel C1 input.
	SMTSIG1 ⁽¹⁾	TTL/ST	—	Signal Measurement Timer1 (SMT1) signal input.
	CCP2 ⁽¹⁾	TTL/ST	CMOS/OD	Capture/compare/PWM2 (default input location for capture function).
	IOCC1	TTL/ST	—	Interrupt-on-change input.
	SOSCI	AN	—	32.768 kHz secondary oscillator crystal driver input.
	RC2/ANC2/T5CKI ⁽¹⁾ /CCP1 ⁽¹⁾ /IOCC2	RC2	TTL/ST	CMOS/OD
ANC2		AN	—	ADC Channel C2 input.
T5CKI ⁽¹⁾		TTL/ST	—	Timer5 external digital clock input.
CCP1 ⁽¹⁾		TTL/ST	CMOS/OD	Capture/compare/PWM1 (default input location for capture function).
IOCC2		TTL/ST	—	Interrupt-on-change input.
RC3/ANC3/SCL1 ^(3,4) /SCK1 ⁽¹⁾ /T2IN ⁽¹⁾ / IOCC3	RC3	TTL/ST	CMOS/OD	General purpose I/O.
	ANC3	AN	—	ADC Channel C3 input.
	SCL1 ^(3,4)	I ² C/ SMBus	OD	MSSP1 I ² C clock input/output.
	SCK1 ⁽¹⁾	TTL/ST	CMOS/OD	MSSP1 SPI clock input/output (default input location, SCK1 is a PPS remappable input and output).
	T2IN ⁽¹⁾	TTL/ST	—	Timer2 external input.
	IOCC3	TTL/ST	—	Interrupt-on-change input.

Legend: AN = Analog input or output CMOS = CMOS compatible input or output OD = Open-Drain
TTL = TTL compatible input ST = Schmitt Trigger input with CMOS levels I²C = Schmitt Trigger input with I²C
HV = High Voltage XTAL = Crystal levels

- Note**
- 1: This is a PPS remappable input signal. The input function may be moved from the default location shown to one of several other PORTx pins. Refer to [Table 13-1](#) for details on which PORT pins may be used for this signal.
 - 2: All output signals shown in this row are PPS remappable. These signals may be mapped to output onto one of several PORTx pin options as described in [Table 13-3](#).
 - 3: This is a bidirectional signal. For normal module operation, the firmware should map this signal to the same pin in both the PPS input and PPS output registers.
 - 4: These pins are configured for I²C logic levels. The SCLx/SDAx signals may be assigned to any of the RB1/RB2/RC3/RC4 pins. PPS assignments to the other pins (e.g., RA5) will operate, but input logic levels will be standard TTL/ST, as selected by the INLVL register, instead of the I²C specific or SMBus input buffer thresholds.

PIC16(L)F18856/76

TABLE 1-2: PIC16F18856 PINOUT DESCRIPTION (CONTINUED)

Name	Function	Input Type	Output Type	Description
RC4/ANC4/SDA1 ^(3,4) /SDI1 ⁽¹⁾ /IOCC4	RC4	TTL/ST	CMOS/OD	General purpose I/O.
	ANC4	AN	—	ADC Channel C4 input.
	SDA1 ^(3,4)	I ² C/ SMBus	OD	MSSP1 I ² C serial data input/output.
	SDI1 ⁽¹⁾	TTL/ST	—	MSSP1 SPI serial data input.
	IOCC4	TTL/ST	—	Interrupt-on-change input.
RC5/ANC5/T4IN ⁽¹⁾ /IOCC5	RC5	TTL/ST	CMOS/OD	General purpose I/O.
	ANC5	AN	—	ADC Channel C5 input.
	T4IN ⁽¹⁾	TTL/ST	—	Timer4 external input.
	IOCC5	TTL/ST	—	Interrupt-on-change input.
RC6/ANC6/CK ⁽³⁾ /IOCC6	RC6	TTL/ST	CMOS/OD	General purpose I/O.
	ANC6	AN	—	ADC Channel C6 input.
	CK ⁽³⁾	TTL/ST	CMOS/OD	EUSART synchronous mode clock input/output.
	IOCC6	TTL/ST	—	Interrupt-on-change input.
RC7/ANC7/RX ⁽¹⁾ /DT ⁽³⁾ /IOCC7	RC7	TTL/ST	CMOS/OD	General purpose I/O.
	ANC7	AN	—	ADC Channel C7 input.
	RX ⁽¹⁾	TTL/ST	—	EUSART Asynchronous mode receiver data input.
	DT ⁽³⁾	TTL/ST	CMOS/OD	EUSART Synchronous mode data input/output.
	IOCC7	TTL/ST	—	Interrupt-on-change input.
RE3/IOCE3/MCLR/VPP	RE3	TTL/ST	—	General purpose input only (when MCLR is disabled by the Configuration bit).
	IOCE3	TTL/ST	—	Interrupt-on-change input.
	MCLR	ST	—	Master clear input with internal weak pull up resistor.
	VPP	HV	—	ICSP™ High-Voltage Programming mode entry input.
VDD	VDD	Power	—	Positive supply voltage input.

Legend: AN = Analog input or output CMOS = CMOS compatible input or output OD = Open-Drain
TTL = TTL compatible input ST = Schmitt Trigger input with CMOS levels I²C = Schmitt Trigger input with I²C
HV = High Voltage XTAL = Crystal levels

- Note**
- 1: This is a PPS remappable input signal. The input function may be moved from the default location shown to one of several other PORTx pins. Refer to [Table 13-1](#) for details on which PORT pins may be used for this signal.
 - 2: All output signals shown in this row are PPS remappable. These signals may be mapped to output onto one of several PORTx pin options as described in [Table 13-3](#).
 - 3: This is a bidirectional signal. For normal module operation, the firmware should map this signal to the same pin in both the PPS input and PPS output registers.
 - 4: These pins are configured for I²C logic levels. The SCLx/SDAx signals may be assigned to any of the RB1/RB2/RC3/RC4 pins. PPS assignments to the other pins (e.g., RA5) will operate, but input logic levels will be standard TTL/ST, as selected by the INLVL register, instead of the I²C specific or SMBus input buffer thresholds.

PIC16(L)F18856/76

TABLE 1-2: PIC16F18856 PINOUT DESCRIPTION (CONTINUED)

Name	Function	Input Type	Output Type	Description
Vss	Vss	Power	—	Ground reference.
OUT ⁽²⁾	ADGRDA	—	CMOS/OD	ADC Guard Ring A output.
	ADGRDB	—	CMOS/OD	ADC Guard Ring B output.
	C1OUT	—	CMOS/OD	Comparator 1 output.
	C2OUT	—	CMOS/OD	Comparator 2 output.
	SDO1	—	CMOS/OD	MSSP1 SPI serial data output.
	SCK1	—	CMOS/OD	MSSP1 SPI serial clock output.
	SDO2	—	CMOS/OD	MSSP2 SPI serial data output.
	SCK2	—	CMOS/OD	MSSP2 SPI serial clock output.
	TX	—	CMOS/OD	EUSART Asynchronous mode transmitter data output.
	CK ⁽³⁾	—	CMOS/OD	EUSART Synchronous mode clock output.
	DT ⁽³⁾	—	CMOS/OD	EUSART Synchronous mode data output.
	DSM	—	CMOS/OD	Data Signal Modulator output.
	TMR0	—	CMOS/OD	Timer0 output.
	CCP1	—	CMOS/OD	Capture/Compare/PWM1 output (compare/PWM functions).
	CCP2	—	CMOS/OD	Capture/Compare/PWM2 output (compare/PWM functions).
	CCP3	—	CMOS/OD	Capture/Compare/PWM3 output (compare/PWM functions).
	CCP4	—	CMOS/OD	Capture/Compare/PWM4 output (compare/PWM functions).
	CCP5	—	CMOS/OD	Capture/Compare/PWM5 output (compare/PWM functions).
	PWM6OUT	—	CMOS/OD	PWM6 output.
	PWM7OUT	—	CMOS/OD	PWM7 output.
	CWG1A	—	CMOS/OD	Complementary Waveform Generator 1 output A.
	CWG1B	—	CMOS/OD	Complementary Waveform Generator 1 output B.
	CWG1C	—	CMOS/OD	Complementary Waveform Generator 1 output C.
	CWG1D	—	CMOS/OD	Complementary Waveform Generator 1 output D.
	CWG2A	—	CMOS/OD	Complementary Waveform Generator 2 output A.
	CWG2B	—	CMOS/OD	Complementary Waveform Generator 2 output B.
	CWG2C	—	CMOS/OD	Complementary Waveform Generator 2 output C.
	CWG2D	—	CMOS/OD	Complementary Waveform Generator 2 output D.
	CWG3A	—	CMOS/OD	Complementary Waveform Generator 3 output A.
	CWG3B	—	CMOS/OD	Complementary Waveform Generator 3 output B.

Legend: AN = Analog input or output CMOS = CMOS compatible input or output OD = Open-Drain
TTL = TTL compatible input ST = Schmitt Trigger input with CMOS levels I²C = Schmitt Trigger input with I²C
HV = High Voltage XTAL = Crystal levels

- Note**
- 1: This is a PPS remappable input signal. The input function may be moved from the default location shown to one of several other PORTx pins. Refer to [Table 13-1](#) for details on which PORT pins may be used for this signal.
 - 2: All output signals shown in this row are PPS remappable. These signals may be mapped to output onto one of several PORTx pin options as described in [Table 13-3](#).
 - 3: This is a bidirectional signal. For normal module operation, the firmware should map this signal to the same pin in both the PPS input and PPS output registers.
 - 4: These pins are configured for I²C logic levels. The SCLx/SDAx signals may be assigned to any of the RB1/RB2/RC3/RC4 pins. PPS assignments to the other pins (e.g., RA5) will operate, but input logic levels will be standard TTL/ST, as selected by the INLVL register, instead of the I²C specific or SMBus input buffer thresholds.

PIC16(L)F18856/76

TABLE 1-2: PIC16F18856 PINOUT DESCRIPTION (CONTINUED)

Name	Function	Input Type	Output Type	Description
OUT ⁽²⁾	CWG3C	—	CMOS/OD	Complementary Waveform Generator 3 output C.
	CWG3D	—	CMOS/OD	Complementary Waveform Generator 3 output D.
	CLC1OUT	—	CMOS/OD	Configurable Logic Cell 1 output.
	CLC2OUT	—	CMOS/OD	Configurable Logic Cell 2 output.
	CLC3OUT	—	CMOS/OD	Configurable Logic Cell 3 output.
	CLC4OUT	—	CMOS/OD	Configurable Logic Cell 4 output.
	NCO1	—	CMOS/OD	Numerically Controller Oscillator output.
	CLKR	—	CMOS/OD	Clock Reference module output.

Legend: AN = Analog input or output CMOS = CMOS compatible input or output OD = Open-Drain
TTL = TTL compatible input ST = Schmitt Trigger input with CMOS levels I²C = Schmitt Trigger input with I²C
HV = High Voltage XTAL = Crystal levels

- Note**
- 1: This is a PPS remappable input signal. The input function may be moved from the default location shown to one of several other PORTx pins. Refer to [Table 13-1](#) for details on which PORT pins may be used for this signal.
 - 2: All output signals shown in this row are PPS remappable. These signals may be mapped to output onto one of several PORTx pin options as described in [Table 13-3](#).
 - 3: This is a bidirectional signal. For normal module operation, the firmware should map this signal to the same pin in both the PPS input and PPS output registers.
 - 4: These pins are configured for I²C logic levels. The SCLx/SDAx signals may be assigned to any of the RB1/RB2/RC3/RC4 pins. PPS assignments to the other pins (e.g., RA5) will operate, but input logic levels will be standard TTL/ST, as selected by the INLVL register, instead of the I²C specific or SMBus input buffer thresholds.

PIC16(L)F18856/76

TABLE 1-3: PIC16F18876 PINOUT DESCRIPTION

Name	Function	Input Type	Output Type	Description
RA0/ANA0/C1IN0-/C2IN0-/CLCIN0 ⁽¹⁾ /IOCA0	RA0	TTL/ST	CMOS/OD	General purpose I/O.
	ANA0	AN	—	ADC Channel A0 input.
	C1IN0-	AN	—	Comparator negative input.
	C2IN0-	AN	—	Comparator negative input.
	CLCIN0 ⁽¹⁾	TTL/ST	—	Configurable Logic Cell source input.
	IOCA0	TTL/ST	—	Interrupt-on-change input.
RA1/ANA1/C1IN1-/C2IN1-/CLCIN1 ⁽¹⁾ /IOCA1	RA1	TTL/ST	CMOS/OD	General purpose I/O.
	ANA1	AN	—	ADC Channel A1 input.
	C1IN1-	AN	—	Comparator negative input.
	C2IN1-	AN	—	Comparator negative input.
	CLCIN1 ⁽¹⁾	TTL/ST	—	Configurable Logic Cell source input.
	IOCA1	TTL/ST	—	Interrupt-on-change input.
RA2/ANA2/C1IN0+/C2IN0+/VREF-/DAC1OUT1/IOCA2	RA2	TTL/ST	CMOS/OD	General purpose I/O.
	ANA2	AN	—	ADC Channel A2 input.
	C1IN0+	AN	—	Comparator positive input.
	C2IN0+	AN	—	Comparator positive input.
	VREF-	AN	—	External ADC and/or DAC negative reference input.
	DAC1OUT1	—	AN	Digital-to-Analog Converter output.
	IOCA2	TTL/ST	—	Interrupt-on-change input.
RA3/ANA3/C1IN1+/VREF+/MDCARL ⁽¹⁾ /IOCA3	RA3	TTL/ST	CMOS/OD	General purpose I/O.
	ANA3	AN	—	ADC Channel A3 input.
	C1IN1+	AN	—	Comparator positive input.
	VREF+	AN	—	External ADC and/or DAC positive reference input.
	MDCARL ⁽¹⁾	TTL/ST	—	Modular Carrier input 1.
	IOCA3	TTL/ST	—	Interrupt-on-change input.
RA4/ANA4/MDCARH ⁽¹⁾ /T0CKI ⁽¹⁾ /CCP5 ⁽¹⁾ /IOCA4	RA4	TTL/ST	CMOS/OD	General purpose I/O.
	ANA4	AN	—	ADC Channel A4 input.
	MDCARH ⁽¹⁾	TTL/ST	—	Modular Carrier input 2.
	T0CKI ⁽¹⁾	TTL/ST	—	Timer0 clock input.
	CCP5 ⁽¹⁾	TTL/ST	CMOS/OD	Capture/compare/PWM5 (default input location for capture function).
	IOCA4	TTL/ST	—	Interrupt-on-change input.

Legend: AN = Analog input or output CMOS = CMOS compatible input or output OD = Open-Drain
TTL = TTL compatible input ST = Schmitt Trigger input with CMOS levels I²C = Schmitt Trigger input with I²CHV=
High Voltage XTAL= Crystal levels

- Note**
- 1: This is a PPS remappable input signal. The input function may be moved from the default location shown to one of several other PORTx pins. Refer to [Table 13-1](#) for details on which PORT pins may be used for this signal.
 - 2: All output signals shown in this row are PPS remappable. These signals may be mapped to output onto one of several PORTx pin options as described in [Table 13-3](#).
 - 3: This is a bidirectional signal. For normal module operation, the firmware should map this signal to the same pin in both the PPS input and PPS output registers.
 - 4: These pins are configured for I²C logic levels. The SCLx/SDAx signals may be assigned to any of the RB1/RB2/RC3/RC4 pins. PPS assignments to the other pins (e.g., RA5) will operate, but input logic levels will be standard TTL/ST, as selected by the INLVL register, instead of the I²C specific or SMBus input buffer thresholds.

PIC16(L)F18856/76

TABLE 1-3: PIC16F18876 PINOUT DESCRIPTION (CONTINUED)

Name	Function	Input Type	Output Type	Description
RA5/ANA5/SS1 ⁽¹⁾ /MDSRC ⁽¹⁾ /IOCA5	RA5	TTL/ST	CMOS/OD	General purpose I/O.
	ANA5	AN	—	ADC Channel A5 input.
	SS1 ⁽¹⁾	TTL/ST	—	MSSP1 SPI slave select input.
	MDSRC ⁽¹⁾	TTL/ST	—	Modulator Source input.
	IOCA5	TTL/ST	—	Interrupt-on-change input.
RA6/ANA6/OSC2/CLKOUT/IOCA6	RA6	TTL/ST	CMOS/OD	General purpose I/O.
	ANA6	AN	—	ADC Channel A6 input.
	OSC2	—	XTAL	External Crystal/Resonator (LP, XT, HS modes) driver output.
	CLKOUT	—	CMOS/OD	Fosc/4 digital output (in non-crystal/resonator modes).
	IOCA6	TTL/ST	—	Interrupt-on-change input.
RA7/ANA7/OSC1/CLKIN/IOCA7	RA7	TTL/ST	CMOS/OD	General purpose I/O.
	ANA7	AN	—	ADC Channel A7 input.
	OSC1	XTAL	—	External Crystal/Resonator (LP, XT, HS modes) driver input.
	CLKIN	TTL/ST	—	External digital clock input.
	IOCA7	TTL/ST	—	Interrupt-on-change input.
RB0/ANB0/C2IN1+/ZCD/SS2 ⁽¹⁾ /CCP4 ⁽¹⁾ /CWG1IN ⁽¹⁾ /INT ⁽¹⁾ /IOCB0	RB0	TTL/ST	CMOS/OD	General purpose I/O.
	ANB0	AN	—	ADC Channel B0 input.
	C2IN1+	AN	—	Comparator positive input.
	ZCD	AN	AN	Zero-cross detect input pin (with constant current sink/source).
	SS2 ⁽¹⁾	TTL/ST	—	MSSP2 SPI slave select input.
	CCP4 ⁽¹⁾	TTL/ST	CMOS/OD	Capture/compare/PWM4 (default input location for capture function).
	CWG1IN ⁽¹⁾	TTL/ST	—	Complementary Waveform Generator 1 input.
	INT ⁽¹⁾	TTL/ST	—	External interrupt request input.
RB1/ANB1/C1IN3-/C2IN3-/SCL2 ^(3,4) /SCK2 ⁽¹⁾ /CWG2IN ⁽¹⁾ /IOCB1	RB1	TTL/ST	CMOS/OD	General purpose I/O.
	ANB1	AN	—	ADC Channel B1 input.
	C1IN3-	AN	—	Comparator negative input.
	C2IN3-	AN	—	Comparator negative input.
	SCL2 ^(3,4)	I ² C/SMBus	OD	MSSP2 I ² C clock input/output.
	SCK2 ⁽¹⁾	TTL/ST	CMOS/OD	MSSP2 SPI serial clock (default input location, SCK2 is a PPS remappable input and output).
	CWG2IN ⁽¹⁾	TTL/ST	—	Complementary Waveform Generator 2 input.
	IOCB1	TTL/ST	—	Interrupt-on-change input.

Legend: AN = Analog input or output CMOS = CMOS compatible input or output OD = Open-Drain
TTL = TTL compatible input ST = Schmitt Trigger input with CMOS levels I²C = Schmitt Trigger input with I²CHV=
High Voltage XTAL= Crystal levels

- Note**
- 1: This is a PPS remappable input signal. The input function may be moved from the default location shown to one of several other PORTx pins. Refer to [Table 13-1](#) for details on which PORT pins may be used for this signal.
 - 2: All output signals shown in this row are PPS remappable. These signals may be mapped to output onto one of several PORTx pin options as described in [Table 13-3](#).
 - 3: This is a bidirectional signal. For normal module operation, the firmware should map this signal to the same pin in both the PPS input and PPS output registers.
 - 4: These pins are configured for I²C logic levels. The SCLx/SDAx signals may be assigned to any of the RB1/RB2/RC3/RC4 pins. PPS assignments to the other pins (e.g., RA5) will operate, but input logic levels will be standard TTL/ST, as selected by the INLVL register, instead of the I²C specific or SMBus input buffer thresholds.

PIC16(L)F18856/76

TABLE 1-3: PIC16F18876 PINOUT DESCRIPTION (CONTINUED)

Name	Function	Input Type	Output Type	Description
RB2/ANB2/SDA2 ^(3,4) /SDI2 ⁽¹⁾ / CWG3IN ⁽¹⁾ /IOCB2	RB2	TTL/ST	CMOS/OD	General purpose I/O.
	ANB2	AN	—	ADC Channel B2 input.
	SDA2 ^(3,4)	I ² C/SMBus	OD	MSSP2 I ² C serial data input/output.
	SDI2 ⁽¹⁾	TTL/ST	—	MSSP2 SPI serial data input.
	CWG3IN ⁽¹⁾	TTL/ST	—	Complementary Waveform Generator 3 input.
	IOCB2	TTL/ST	—	Interrupt-on-change input.
RB3/ANB3/C1IN2-/C2IN2-/IOCB3	RB3	TTL/ST	CMOS/OD	General purpose I/O.
	ANB3	AN	—	ADC Channel B3 input.
	C1IN2-	AN	—	Comparator negative input.
	C2IN2-	AN	—	Comparator negative input.
	IOCB3	TTL/ST	—	Interrupt-on-change input.
RB4/ANB4/ADCACT ⁽¹⁾ /T5G ⁽¹⁾ / SMTWIN2 ⁽¹⁾ /IOCB4	RB4	TTL/ST	CMOS/OD	General purpose I/O.
	ANB4	AN	—	ADC Channel B4 input.
	ADCACT ⁽¹⁾	TTL/ST	—	ADC Auto-Conversion Trigger input.
	T5G ⁽¹⁾	TTL/ST	—	Timer5 gate input.
	SMTWIN2 ⁽¹⁾	TTL/ST	—	Signal Measurement Timer2 (SMT2) window input.
RB5/ANB5/T1G ⁽¹⁾ /SMTSIG2 ⁽¹⁾ / CCP3 ⁽¹⁾ /IOCB5	RB5	TTL/ST	CMOS/OD	General purpose I/O.
	ANB5	AN	—	ADC Channel B5 input.
	T1G ⁽¹⁾	TTL/ST	—	Timer1 gate input.
	SMTSIG2 ⁽¹⁾	TTL/ST	—	Signal Measurement Timer2 (SMT2) signal input.
	CCP3 ⁽¹⁾	TTL/ST	CMOS/OD	Capture/compare/PWM3 (default input location for capture function).
RB6/ANB6/CLCIN2 ⁽¹⁾ /IOCB6/ ICSPCLK	RB6	TTL/ST	CMOS/OD	General purpose I/O.
	ANB6	AN	—	ADC Channel B6 input.
	CLCIN2 ⁽¹⁾	TTL/ST	—	Configurable Logic Cell source input.
	IOCB6	TTL/ST	—	Interrupt-on-change input.
	ICSPCLK	ST	—	In-Circuit Serial Programming™ and debugging clock input.
RB7/ANB7/DAC1OUT2/T6IN ⁽¹⁾ / CLCIN3 ⁽¹⁾ /IOCB7/ICSPDAT	RB7	TTL/ST	CMOS/OD	General purpose I/O.
	ANB7	AN	—	ADC Channel B7 input.
	DAC1OUT2	—	AN	Digital-to-Analog Converter output.
	T6IN ⁽¹⁾	TTL/ST	—	Timer6 external digital clock input.
	CLCIN3 ⁽¹⁾	TTL/ST	—	Configurable Logic Cell source input.
	IOCB7	TTL/ST	—	Interrupt-on-change input.
	ICSPDAT	ST	CMOS	In-Circuit Serial Programming™ and debugging data input/output.

Legend: AN = Analog input or output CMOS = CMOS compatible input or output OD = Open-Drain
TTL = TTL compatible input ST = Schmitt Trigger input with CMOS levels I²C = Schmitt Trigger input with I²CHV=
High Voltage XTAL= Crystal levels

- Note**
- 1: This is a PPS remappable input signal. The input function may be moved from the default location shown to one of several other PORTx pins. Refer to [Table 13-1](#) for details on which PORT pins may be used for this signal.
 - 2: All output signals shown in this row are PPS remappable. These signals may be mapped to output onto one of several PORTx pin options as described in [Table 13-3](#).
 - 3: This is a bidirectional signal. For normal module operation, the firmware should map this signal to the same pin in both the PPS input and PPS output registers.
 - 4: These pins are configured for I²C logic levels. The SCLx/SDAx signals may be assigned to any of the RB1/RB2/RC3/RC4 pins. PPS assignments to the other pins (e.g., RA5) will operate, but input logic levels will be standard TTL/ST, as selected by the INLVL register, instead of the I²C specific or SMBus input buffer thresholds.

PIC16(L)F18856/76

TABLE 1-3: PIC16F18876 PINOUT DESCRIPTION (CONTINUED)

Name	Function	Input Type	Output Type	Description
RC0/ANC0/T1CKI ⁽¹⁾ /T3CKI ⁽¹⁾ /T3G ⁽¹⁾ /SMTWIN1 ⁽¹⁾ /IOCC0/SOSCO	RC0	TTL/ST	CMOS/OD	General purpose I/O.
	ANC0	AN	—	ADC Channel C0 input.
	T1CKI ⁽¹⁾	TTL/ST	—	Timer1 external digital clock input.
	T3CKI ⁽¹⁾	TTL/ST	—	Timer3 external digital clock input.
	T3G ⁽¹⁾	TTL/ST	—	Timer3 gate input.
	SMTWIN1 ⁽¹⁾	TTL/ST	—	Signal Measurement Timer1 (SMT1) input.
	IOCC0	TTL/ST	—	Interrupt-on-change input.
RC1/ANC1/SMTSIG1 ⁽¹⁾ /CCP2 ⁽¹⁾ /IOCC1/SOSCI	RC1	TTL/ST	CMOS/OD	General purpose I/O.
	ANC1	AN	—	ADC Channel C1 input.
	SMTSIG1 ⁽¹⁾	TTL/ST	—	Signal Measurement Timer1 (SMT1) signal input.
	CCP2 ⁽¹⁾	TTL/ST	CMOS/OD	Capture/compare/PWM2 (default input location for capture function).
	IOCC1	TTL/ST	—	Interrupt-on-change input.
	SOSCI	AN	—	32.768 kHz secondary oscillator crystal driver input.
RC2/ANC2/T5CKI ⁽¹⁾ /CCP1 ⁽¹⁾ /IOCC2	RC2	TTL/ST	CMOS/OD	General purpose I/O.
	ANC2	AN	—	ADC Channel C2 input.
	T5CKI ⁽¹⁾	TTL/ST	—	Timer5 external digital clock input.
	CCP1 ⁽¹⁾	TTL/ST	CMOS/OD	Capture/compare/PWM1 (default input location for capture function).
	IOCC2	TTL/ST	—	Interrupt-on-change input.
RC3/ANC3/SCL1 ^(3,4) /SCK1 ⁽¹⁾ /T2IN ⁽¹⁾ /IOCC3	RC3	TTL/ST	CMOS/OD	General purpose I/O.
	ANC3	AN	—	ADC Channel C3 input.
	SCL1 ^(3,4)	I ² C/SMBus	OD	MSSP1 I ² C clock input/output.
	SCK1 ⁽¹⁾	TTL/ST	CMOS/OD	MSSP1 SPI clock input/output (default input location, SCK1 is a PPS remappable input and output).
	T2IN ⁽¹⁾	TTL/ST	—	Timer2 external input.
	IOCC3	TTL/ST	—	Interrupt-on-change input.
RC4/ANC4/SDA1 ^(3,4) /SDI1 ⁽¹⁾ /IOCC4	RC4	TTL/ST	CMOS/OD	General purpose I/O.
	ANC4	AN	—	ADC Channel C4 input.
	SDA1 ^(3,4)	I ² C/SMBus	OD	MSSP1 I ² C serial data input/output.
	SDI1 ⁽¹⁾	TTL/ST	—	MSSP1 SPI serial data input.
	IOCC4	TTL/ST	—	Interrupt-on-change input.
RC5/ANC5/T4IN ⁽¹⁾ /IOCC5	RC5	TTL/ST	CMOS/OD	General purpose I/O.
	ANC5	AN	—	ADC Channel C5 input.
	T4IN ⁽¹⁾	TTL/ST	—	Timer4 external input.
	IOCC5	TTL/ST	—	Interrupt-on-change input.

Legend: AN = Analog input or output CMOS = CMOS compatible input or output OD = Open-Drain
TTL = TTL compatible input ST = Schmitt Trigger input with CMOS levels I²C = Schmitt Trigger input with I²CHV=
High Voltage XTAL= Crystal levels

- Note**
- 1: This is a PPS remappable input signal. The input function may be moved from the default location shown to one of several other PORTx pins. Refer to [Table 13-1](#) for details on which PORT pins may be used for this signal.
 - 2: All output signals shown in this row are PPS remappable. These signals may be mapped to output onto one of several PORTx pin options as described in [Table 13-3](#).
 - 3: This is a bidirectional signal. For normal module operation, the firmware should map this signal to the same pin in both the PPS input and PPS output registers.
 - 4: These pins are configured for I²C logic levels. The SCLx/SDAx signals may be assigned to any of the RB1/RB2/RC3/RC4 pins. PPS assignments to the other pins (e.g., RA5) will operate, but input logic levels will be standard TTL/ST, as selected by the INLVL register, instead of the I²C specific or SMBus input buffer thresholds.

PIC16(L)F18856/76

TABLE 1-3: PIC16F18876 PINOUT DESCRIPTION (CONTINUED)

Name	Function	Input Type	Output Type	Description
RC6/ANC6/CK ⁽³⁾ /IOCC6	RC6	TTL/ST	CMOS/OD	General purpose I/O.
	ANC6	AN	—	ADC Channel C6 input.
	CK ⁽³⁾	TTL/ST	CMOS/OD	EUSART synchronous mode clock input/output.
	IOCC6	TTL/ST	—	Interrupt-on-change input.
RC7/ANC7/RX ⁽¹⁾ /DT ⁽³⁾ /IOCC7	RC7	TTL/ST	CMOS/OD	General purpose I/O.
	ANC7	AN	—	ADC Channel C7 input.
	RX ⁽¹⁾	TTL/ST	—	EUSART Asynchronous mode receiver data input.
	DT ⁽³⁾	TTL/ST	CMOS/OD	EUSART Synchronous mode data input/output.
RD0	RD0	TTL/ST	CMOS/OD	General purpose I/O.
	AND0	AN	—	ADC Channel D0 input.
RD1	RD1	TTL/ST	CMOS/OD	General purpose I/O.
	AND1	AN	—	ADC Channel D1 input.
RD2	RD2	TTL/ST	CMOS/OD	General purpose I/O.
	AND2	AN	—	ADC Channel D2 input.
RD3	RD3	TTL/ST	CMOS/OD	General purpose I/O.
	AND3	AN	—	ADC Channel D3 input.
RD4	RD4	TTL/ST	CMOS/OD	General purpose I/O.
	AND4	AN	—	ADC Channel D4 input.
RD5	RD5	TTL/ST	CMOS/OD	General purpose I/O.
	AND5	AN	—	ADC Channel D5 input.
RD6	RD6	TTL/ST	CMOS/OD	General purpose I/O.
	AND6	AN	—	ADC Channel D6 input.
RD7	RD7	TTL/ST	CMOS/OD	General purpose I/O.
	AND7	AN	—	ADC Channel D7 input.
RE0	RE0	TTL/ST	CMOS/OD	General purpose I/O.
	ANE0	AN	—	ADC Channel E0 input.
RE1	RE1	TTL/ST	CMOS/OD	General purpose I/O.
	ANE1	AN	—	ADC Channel E1 input.
RE2	RE2	TTL/ST	CMOS/OD	General purpose I/O.
	ANE2	AN	—	ADC Channel E2 input.
RE3/IOCE3/ $\overline{\text{MCLR}}$ /VPP	RE3	TTL/ST	—	General purpose input-only (when $\overline{\text{MCLR}}$ is disabled by config bit).
	IOCE3	TTL/ST	—	Interrupt-on-change input.
	$\overline{\text{MCLR}}$	ST	—	Master clear input with internal weak pull-up resistor.
	VPP	HV	—	ICSP™ high voltage programming mode entry input.
VDD	VDD	Power	—	Positive supply voltage input.

Legend: AN = Analog input or output CMOS = CMOS compatible input or output OD = Open-Drain
TTL = TTL compatible input ST = Schmitt Trigger input with CMOS levels I²C = Schmitt Trigger input with I²CHV=
High Voltage XTAL= Crystal levels

- Note**
- 1: This is a PPS remappable input signal. The input function may be moved from the default location shown to one of several other PORTx pins. Refer to [Table 13-1](#) for details on which PORT pins may be used for this signal.
 - 2: All output signals shown in this row are PPS remappable. These signals may be mapped to output onto one of several PORTx pin options as described in [Table 13-3](#).
 - 3: This is a bidirectional signal. For normal module operation, the firmware should map this signal to the same pin in both the PPS input and PPS output registers.
 - 4: These pins are configured for I²C logic levels. The SCLx/SDAx signals may be assigned to any of the RB1/RB2/RC3/RC4 pins. PPS assignments to the other pins (e.g., RA5) will operate, but input logic levels will be standard TTL/ST, as selected by the INLVL register, instead of the I²C specific or SMBus input buffer thresholds.

PIC16(L)F18856/76

TABLE 1-3: PIC16F18876 PINOUT DESCRIPTION (CONTINUED)

Name	Function	Input Type	Output Type	Description
Vss	Vss	Power	—	Ground reference.
OUT ⁽²⁾	ADGRDA	—	CMOS/OD	ADC Guard Ring A output.
	ADGRDB	—	CMOS/OD	ADC Guard Ring B output.
	C1OUT	—	CMOS/OD	Comparator 1 output.
	C2OUT	—	CMOS/OD	Comparator 2 output.
	SDO1	—	CMOS/OD	MSSP1 SPI serial data output.
	SCK1	—	CMOS/OD	MSSP1 SPI serial clock output.
	SDO2	—	CMOS/OD	MSSP2 SPI serial data output.
	SCK2	—	CMOS/OD	MSSP2 SPI serial clock output.
	TX	—	CMOS/OD	EUSART Asynchronous mode transmitter data output.
	CK(3)	—	CMOS/OD	EUSART Synchronous mode clock output.
	DT(3)	—	CMOS/OD	EUSART Synchronous mode data output.
	DSM	—	CMOS/OD	Data Signal Modulator output.
	TMR0	—	CMOS/OD	Timer0 output.
	CCP1	—	CMOS/OD	Capture/Compare/PWM1 output (compare/PWM functions).
CCP2	—	CMOS/OD	Capture/Compare/PWM2 output (compare/PWM functions).	

Legend: AN = Analog input or output CMOS = CMOS compatible input or output OD = Open-Drain
TTL = TTL compatible input ST = Schmitt Trigger input with CMOS levels I²C = Schmitt Trigger input with I²CHV=
High Voltage XTAL= Crystal levels

- Note**
- 1: This is a PPS remappable input signal. The input function may be moved from the default location shown to one of several other PORTx pins. Refer to [Table 13-1](#) for details on which PORT pins may be used for this signal.
 - 2: All output signals shown in this row are PPS remappable. These signals may be mapped to output onto one of several PORTx pin options as described in [Table 13-3](#).
 - 3: This is a bidirectional signal. For normal module operation, the firmware should map this signal to the same pin in both the PPS input and PPS output registers.
 - 4: These pins are configured for I²C logic levels. The SCLx/SDAx signals may be assigned to any of the RB1/RB2/RC3/RC4 pins. PPS assignments to the other pins (e.g., RA5) will operate, but input logic levels will be standard TTL/ST, as selected by the INLVL register, instead of the I²C specific or SMBus input buffer thresholds.

PIC16(L)F18856/76

TABLE 1-3: PIC16F18876 PINOUT DESCRIPTION (CONTINUED)

Name	Function	Input Type	Output Type	Description
OUT ⁽²⁾	CCP3	—	CMOS/OD	Capture/Compare/PWM3 output (compare/PWM functions).
	CCP4	—	CMOS/OD	Capture/Compare/PWM4 output (compare/PWM functions).
	CCP5	—	CMOS/OD	Capture/Compare/PWM5 output (compare/PWM functions).
	PWM6OUT	—	CMOS/OD	PWM6 output.
	PWM7OUT	—	CMOS/OD	PWM7 output.
	CWG1A	—	CMOS/OD	Complementary Waveform Generator 1 output A.
	CWG1B	—	CMOS/OD	Complementary Waveform Generator 1 output B.
	CWG1C	—	CMOS/OD	Complementary Waveform Generator 1 output C.
	CWG1D	—	CMOS/OD	Complementary Waveform Generator 1 output D.
	CWG2A	—	CMOS/OD	Complementary Waveform Generator 2 output A.
	CWG2B	—	CMOS/OD	Complementary Waveform Generator 2 output B.
	CWG2C	—	CMOS/OD	Complementary Waveform Generator 2 output C.
	CWG2D	—	CMOS/OD	Complementary Waveform Generator 2 output D.
	CWG3A	—	CMOS/OD	Complementary Waveform Generator 3 output A.
	CWG3B	—	CMOS/OD	Complementary Waveform Generator 3 output B.
	CWG3C	—	CMOS/OD	Complementary Waveform Generator 3 output C.
	CWG3D	—	CMOS/OD	Complementary Waveform Generator 3 output D.
	CLC1OUT	—	CMOS/OD	Configurable Logic Cell 1 output.
	CLC2OUT	—	CMOS/OD	Configurable Logic Cell 2 output.
	CLC3OUT	—	CMOS/OD	Configurable Logic Cell 3 output.
CLC4OUT	—	CMOS/OD	Configurable Logic Cell 4 output.	
NCO	—	CMOS/OD	Numerically Controller Oscillator output.	
CLKR	—	CMOS/OD	Clock Reference module output.	

Legend: AN = Analog input or output CMOS = CMOS compatible input or output OD = Open-Drain
TTL = TTL compatible input ST = Schmitt Trigger input with CMOS levels I²C = Schmitt Trigger input with I²CHV=
High Voltage XTAL= Crystal levels

- Note**
- 1: This is a PPS remappable input signal. The input function may be moved from the default location shown to one of several other PORTx pins. Refer to [Table 13-1](#) for details on which PORT pins may be used for this signal.
 - 2: All output signals shown in this row are PPS remappable. These signals may be mapped to output onto one of several PORTx pin options as described in [Table 13-3](#).
 - 3: This is a bidirectional signal. For normal module operation, the firmware should map this signal to the same pin in both the PPS input and PPS output registers.
 - 4: These pins are configured for I²C logic levels. The SCLx/SDAx signals may be assigned to any of the RB1/RB2/RC3/RC4 pins. PPS assignments to the other pins (e.g., RA5) will operate, but input logic levels will be standard TTL/ST, as selected by the INLVL register, instead of the I²C specific or SMBus input buffer thresholds.

PIC16(L)F18856/76

2.0 ENHANCED MID-RANGE CPU

This family of devices contains an enhanced mid-range 8-bit CPU core. The CPU has 49 instructions. Interrupt capability includes automatic context saving. The hardware stack is 16-levels deep and has Overflow and Underflow Reset capability. Direct, Indirect, and

Relative Addressing modes are available. Two File Select Registers (FSRs) provide the ability to read program and data memory.

- Automatic Interrupt Context Saving
- 16-level Stack with Overflow and Underflow
- File Select Registers
- Instruction Set

FIGURE 2-1: CORE BLOCK DIAGRAM

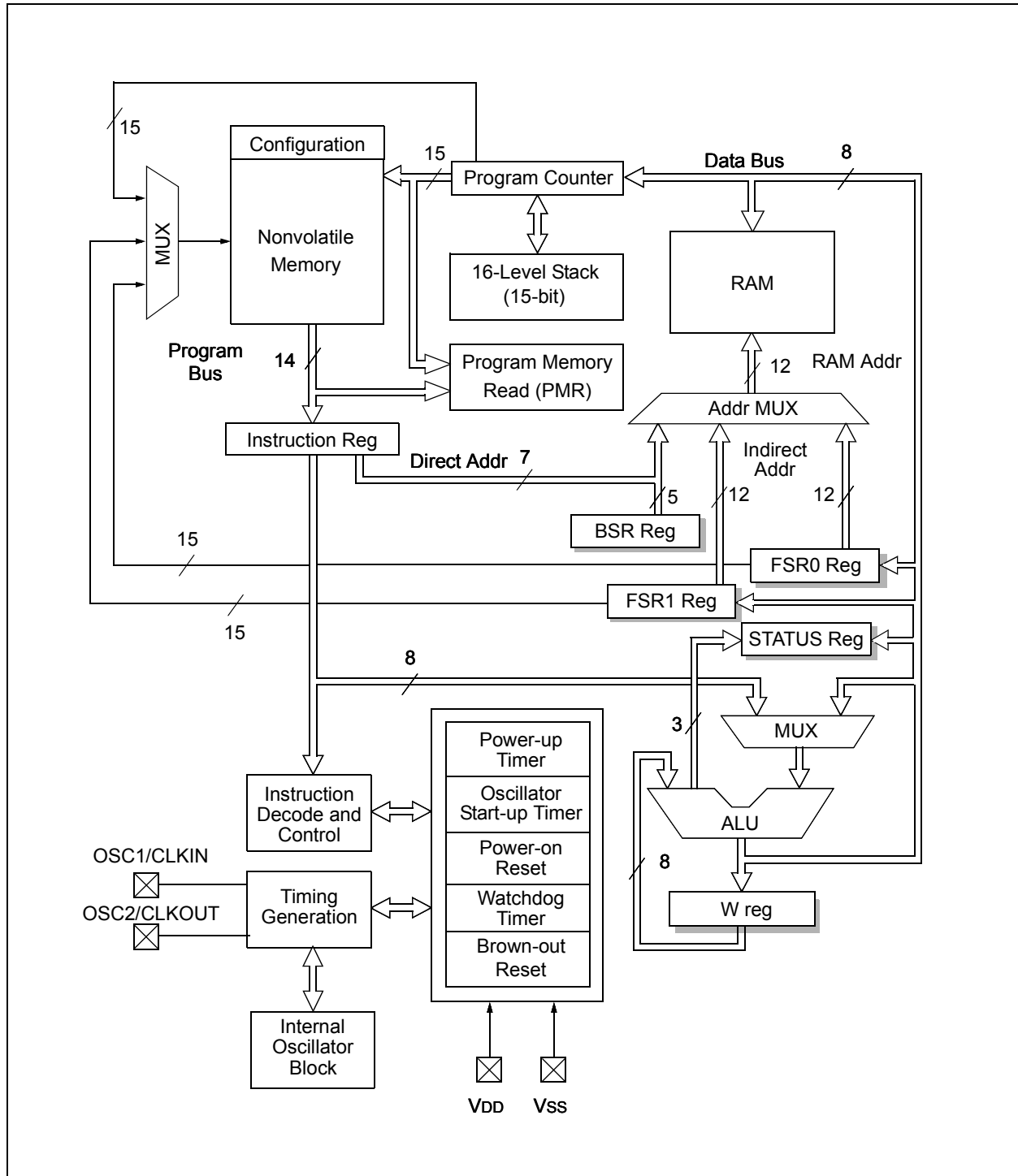

PIC16(L)F18856/76

2.1 Automatic Interrupt Context Saving

During interrupts, certain registers are automatically saved in shadow registers and restored when returning from the interrupt. This saves stack space and user code. See [Section 7.5 “Automatic Context Saving”](#) for more information.

2.2 16-Level Stack with Overflow and Underflow

These devices have a hardware stack memory 15 bits wide and 16 words deep. A Stack Overflow or Underflow will set the appropriate bit (STKOVF or STKUNF) in the PCON register, and if enabled, will cause a software Reset. See [Section 3.4 “Stack”](#) for more details.

2.3 File Select Registers

There are two 16-bit File Select Registers (FSR). FSRs can access all file registers and program memory, which allows one Data Pointer for all memory. When an FSR points to program memory, there is one additional instruction cycle in instructions using INDF to allow the data to be fetched. General purpose memory can now also be addressed linearly, providing the ability to access contiguous data larger than 80 bytes. There are also new instructions to support the FSRs. See [Section 3.5 “Indirect Addressing”](#) for more details.

2.4 Instruction Set

There are 49 instructions for the enhanced mid-range CPU to support the features of the CPU. See [Section 36.0 “Instruction Set Summary”](#) for more details.

PIC16(L)F18856/76

3.0 MEMORY ORGANIZATION

These devices contain the following types of memory:

- Program Memory
 - Configuration Words
 - Device ID
 - User ID
 - Program Flash Memory
- Data Memory
 - Core Registers
 - Special Function Registers
 - General Purpose RAM
 - Common RAM
 - Data EEPROM Memory

The following features are associated with access and control of program memory and data memory:

- PCL and PCLATH
- Stack
- Indirect Addressing
- NVMREG access

3.1 Program Memory Organization

The enhanced mid-range core has a 15-bit program counter capable of addressing 32K x 14 program memory space. [Table 3-1](#) shows the memory sizes implemented. Accessing a location above these boundaries will cause a wrap-around within the implemented memory space. The Reset vector is at 0000h and the interrupt vector is at 0004h (see [Figure 3-1](#)).

TABLE 3-1: DEVICE SIZES AND ADDRESSES

Device	Program Memory Size (Words)	Last Program Memory Address
PIC16(L)F18856/76	16,384	3FFFh

PIC16(L)F18856/76

FIGURE 3-1: PROGRAM MEMORY MAP AND STACK FOR PIC16(L)F18856/76

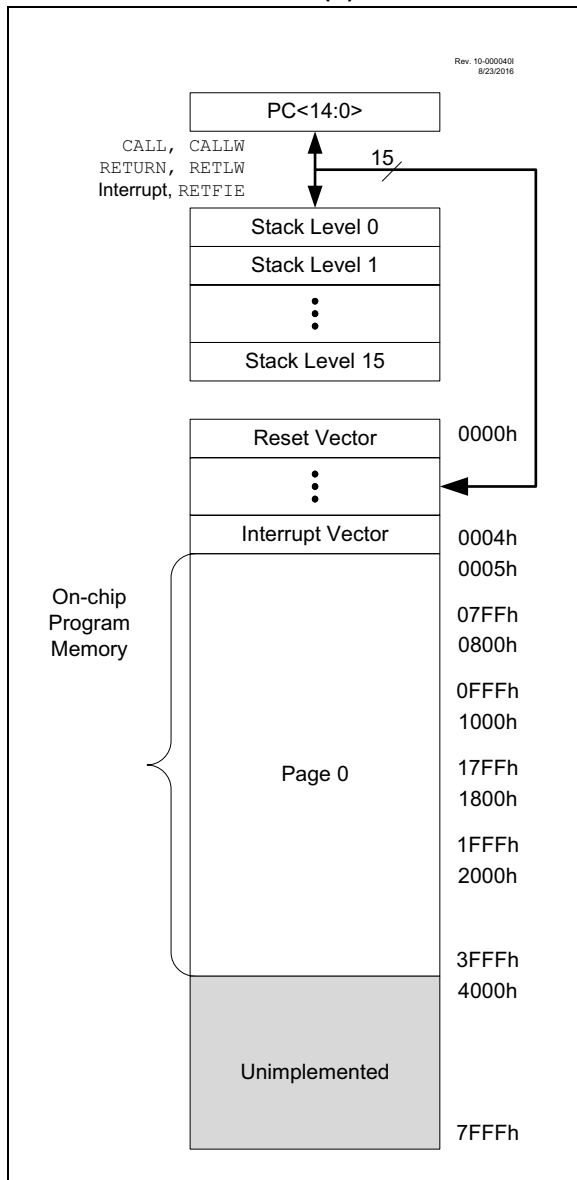

3.1.1 READING PROGRAM MEMORY AS DATA

There are two methods of accessing constants in program memory. The first method is to use tables of RETLW instructions. The second method is to set an FSR to point to the program memory.

3.1.1.1 RETLW Instruction

The RETLW instruction can be used to provide access to tables of constants. The recommended way to create such a table is shown in [Example 3-1](#).

EXAMPLE 3-1: RETLW INSTRUCTION

```
constants
    BRW                ;Add Index in W to
                       ;program counter to
                       ;select data
    RETLW DATA0       ;Index0 data
    RETLW DATA1       ;Index1 data
    RETLW DATA2
    RETLW DATA3

my_function
    ;... LOTS OF CODE...
    MOVLW DATA_INDEX
    call constants
    ;... THE CONSTANT IS IN W
```

The BRW instruction makes this type of table very simple to implement. If your code must remain portable with previous generations of microcontrollers, the older table read method must be used because the BRW instruction is not available in some devices.

PIC16(L)F18856/76

3.1.1.2 Indirect Read with FSR

The program memory can be accessed as data by setting bit 7 of the FSRxH register and reading the matching INDFx register. The `MOVIW` instruction will place the lower eight bits of the addressed word in the W register. Writes to the program memory cannot be performed via the INDF registers. Instructions that access the program memory via the FSR require one extra instruction cycle to complete. [Example 3-2](#) demonstrates accessing the program memory via an FSR.

The `HIGH` directive will set bit 7 if a label points to a location in the program memory.

EXAMPLE 3-2: ACCESSING PROGRAM MEMORY VIA FSR

```
constants
    RETLW DATA0      ;Index0 data
    RETLW DATA1      ;Index1 data
    RETLW DATA2
    RETLW DATA3
my_function
    ;... LOTS OF CODE...
    MOVLW LOW constants
    MOVWF FSR1L
    MOVLW HIGH constants
    MOVWF FSR1H
    MOVIW 0[FSR1]
;THE PROGRAM MEMORY IS IN W
```

3.2 Data Memory Organization

The data memory is partitioned into 32 memory banks with 128 bytes in each bank. Each bank consists of ([Figure 3-2](#)):

- 12 core registers
- 20 Special Function Registers (SFR)
- Up to 80 bytes of General Purpose RAM (GPR)
- 16 bytes of common RAM

The active bank is selected by writing the bank number into the Bank Select Register (BSR). Unimplemented memory will read as '0'. All data memory can be accessed either directly (via instructions that use the file registers) or indirectly via the two File Select Registers (FSR). See [Section 3.5 "Indirect Addressing"](#) for more information.

Data memory uses a 12-bit address. The upper five bits of the address define the Bank address and the lower seven bits select the registers/RAM in that bank.

3.2.1 CORE REGISTERS

The core registers contain the registers that directly affect the basic operation. The core registers occupy the first 12 addresses of every data memory bank (addresses `x00h/x08h` through `x0Bh/x8Bh`). These registers are listed below in [Table 3-2](#). For detailed information, see [Table 3-12](#).

TABLE 3-2: CORE REGISTERS

Addresses	BANKx
<code>x00h</code> or <code>x80h</code>	INDF0
<code>x01h</code> or <code>x81h</code>	INDF1
<code>x02h</code> or <code>x82h</code>	PCL
<code>x03h</code> or <code>x83h</code>	STATUS
<code>x04h</code> or <code>x84h</code>	FSR0L
<code>x05h</code> or <code>x85h</code>	FSR0H
<code>x06h</code> or <code>x86h</code>	FSR1L
<code>x07h</code> or <code>x87h</code>	FSR1H
<code>x08h</code> or <code>x88h</code>	BSR
<code>x09h</code> or <code>x89h</code>	WREG
<code>x0Ah</code> or <code>x8Ah</code>	PCLATH
<code>x0Bh</code> or <code>x8Bh</code>	INTCON

PIC16(L)F18856/76

3.2.1.1 STATUS Register

The STATUS register, shown in [Register 3-1](#), contains:

- the arithmetic status of the ALU
- the Reset status

The STATUS register can be the destination for any instruction, like any other register. If the STATUS register is the destination for an instruction that affects the Z, DC or C bits, then the write to these three bits is disabled. These bits are set or cleared according to the device logic. Furthermore, the $\overline{\text{TO}}$ and $\overline{\text{PD}}$ bits are not writable. Therefore, the result of an instruction with the STATUS register as destination may be different than intended.

For example, `CLRF STATUS` will clear the upper three bits and set the Z bit. This leaves the STATUS register as '000u u1uu' (where u = unchanged).

It is recommended, therefore, that only `BCF`, `BSF`, `SWAPF` and `MOVWF` instructions are used to alter the STATUS register, because these instructions do not affect any Status bits. For other instructions not affecting any Status bits (refer to [Section 3.0 "Memory Organization"](#)).

Note 1: The $\overline{\text{C}}$ and $\overline{\text{DC}}$ bits operate as Borrow and Digit Borrow out bits, respectively, in subtraction.

REGISTER 3-1: STATUS: STATUS REGISTER

U-0	U-0	U-0	R-1/q	R-1/q	R/W-0/u	R/W-0/u	R/W-0/u	
—	—	—	$\overline{\text{TO}}$	$\overline{\text{PD}}$	Z	$\overline{\text{DC}}^{(1)}$	$\overline{\text{C}}^{(1)}$	
bit 7								bit 0

Legend:

R = Readable bit	W = Writable bit	U = Unimplemented bit, read as '0'
u = Bit is unchanged	x = Bit is unknown	-n/n = Value at POR and BOR/Value at all other Resets
'1' = Bit is set	'0' = Bit is cleared	q = Value depends on condition

- bit 7-5 **Unimplemented:** Read as '0'
- bit 4 **TO:** Time-Out bit
 1 = After power-up, `CLRWDT` instruction or `SLEEP` instruction
 0 = A WDT time-out occurred
- bit 3 **PD:** Power-Down bit
 1 = After power-up or by the `CLRWDT` instruction
 0 = By execution of the `SLEEP` instruction
- bit 2 **Z:** Zero bit
 1 = The result of an arithmetic or logic operation is zero
 0 = The result of an arithmetic or logic operation is not zero
- bit 1 **DC:** Digit Carry/Digit Borrow bit (`ADDWF`, `ADDLW`, `SUBLW`, `SUBWF` instructions)⁽¹⁾
 1 = A carry-out from the 4th low-order bit of the result occurred
 0 = No carry-out from the 4th low-order bit of the result
- bit 0 **C:** Carry/Borrow bit⁽¹⁾ (`ADDWF`, `ADDLW`, `SUBLW`, `SUBWF` instructions)⁽¹⁾
 1 = A carry-out from the Most Significant bit of the result occurred
 0 = No carry-out from the Most Significant bit of the result occurred

Note 1: For $\overline{\text{Borrow}}$, the polarity is reversed. A subtraction is executed by adding the two's complement of the second operand. For rotate (`RRF`, `RLF`) instructions, this bit is loaded with either the high-order or low-order bit of the source register.

PIC16(L)F18856/76

3.2.2 SPECIAL FUNCTION REGISTER

The Special Function Registers are registers used by the application to control the desired operation of peripheral functions in the device. The Special Function Registers occupy the 20 bytes after the core registers of every data memory bank (addresses x0Ch/x8Ch through x1Fh/x9Fh). The registers associated with the operation of the peripherals are described in the appropriate peripheral chapter of this data sheet.

3.2.3 GENERAL PURPOSE RAM

There are up to 80 bytes of GPR in each data memory bank. The Special Function Registers occupy the 20 bytes after the core registers of every data memory bank (addresses x0Ch/x8Ch through x1Fh/x9Fh).

3.2.3.1 Linear Access to GPR

The general purpose RAM can be accessed in a non-banked method via the FSRs. This can simplify access to large memory structures. See [Section 3.5.2 “Linear Data Memory”](#) for more information.

3.2.4 COMMON RAM

There are 16 bytes of common RAM accessible from all banks.

FIGURE 3-2: BANKED MEMORY PARTITIONING



3.2.5 DEVICE MEMORY MAPS

The memory maps are as shown in [Table 3-3](#) through [Table 3-13](#).

TABLE 3-3: PIC16(L)F18856 MEMORY MAP BANK 0-7

BANK 0		BANK 1		BANK 2		BANK 3		BANK 4		BANK 5		BANK 6	
000h	Core Registers (Table 3-2)	080h	Core Registers (Table 3-2)	100h	Core Registers (Table 3-2)	180h	Core Registers (Table 3-2)	200h	Core Registers (Table 3-2)	280h	Core Registers (Table 3-2)	300h	Core Registers (Table 3-2)
00Bh	—	08Bh	—	10Bh	—	18Bh	—	20Bh	—	28Bh	—	30Bh	—
00Ch	PORTA	08Ch	ADRESL	10Ch	ADCNT	18Ch	SSP1BUF	20Ch	TMR1L	28Ch	T2TMR	30Ch	CCP1
00Dh	PORTB	08Dh	ADRESH	10Dh	ADRPT	18Dh	SSP1ADD	20Dh	TMR1H	28Dh	T2PR	30Dh	CCP1
00Eh	PORTC	08Eh	ADPREVL	10Eh	ADLTHL	18Eh	SSP1MSK	20Eh	T1CON	28Eh	T2CON	30Eh	CCP1
00Fh	—	08Fh	ADPREVH	10Fh	ADLTHH	18Fh	SSP1STAT	20Fh	T1GCON	28Fh	T2HLT	30Fh	CCP1
010h	PORTE	090h	ADACCL	110h	ADUTHH	190h	SSP1CON1	210h	T1GATE	290h	T2CLKCON	310h	CCP1
011h	TRISA	091h	ADACCH	111h	ADUTHH	191h	SSP1CON2	211h	T1CLK	291h	T2RST	311h	CCP1
012h	TRISB	092h	—	112h	ADSTPTL	192h	SSP1CON3	212h	TMR3L	292h	T4TMR	312h	CCP2
013h	TRISC	093h	ADCON0	113h	ADSTPTH	193h	—	213h	TMR3H	293h	T4PR	313h	CCP2
014h	—	094h	ADCON1	114h	ADFLTRL	194h	—	214h	T3CON	294h	T4CON	314h	CCP1
015h	—	095h	ADCON2	115h	ADFLTRH	195h	—	215h	T3GCON	295h	T4HLT	315h	CCP1
016h	LATA	096h	ADCON3	116h	ADERRL	196h	SSP2BUF	216h	T3GATE	296h	T4CLKCON	316h	CCP3
017h	LATB	097h	ADSTAT	117h	ADERRH	197h	SSP2ADD	217h	T3CLK	297h	T4RST	317h	CCP3
018h	LATC	098h	ADCLK	118h	—	198h	SSP2MSK	218h	TMR5L	298h	T6TMR	318h	CCP1
019h	—	099h	ADACT	119h	RC1REG	199h	SSP2STAT	219h	TMR5H	299h	T6PR	319h	CCP1
01Ah	—	09Ah	ADREF	11Ah	TX1REG	19Ah	SSP2CON1	21Ah	T5CON	29Ah	T6CON	31Ah	CCP4
01Bh	—	09Bh	ADCAP	11Bh	SP1BRGL	19Bh	SSP2CON2	21Bh	T5GCON	29Bh	T6HLT	31Bh	CCP4
01Ch	TMR0L	09Ch	ADPRE	11Ch	SP1BRGH	19Ch	SSP2CON3	21Ch	T5GATE	29Ch	T6CLKCON	31Ch	CCP1
01Dh	TMR0H	09Dh	ADACQ	11Dh	RC1STA	19Dh	—	21Dh	T5CLK	29Dh	T6RST	31Dh	CCP1
01Eh	T0CON0	09Eh	ADPCH	11Eh	TX1STA	19Eh	—	21Eh	CCPTMRS0	29Eh	—	31Eh	CCP5
01Fh	T0CON1	09Fh	—	11Fh	BAUD1CON	19Fh	—	21Fh	CCPTMRS1	29Fh	—	31Fh	CCP5
020h	—	0A0h	—	120h	—	1A0h	—	220h	—	2A0h	—	320h	—
	General Purpose Register 96 Bytes		General Purpose Register 80 Bytes		General Purpose Register 80 Bytes		General Purpose Register 80 Bytes		General Purpose Register 80 Bytes		General Purpose Register 80 Bytes		General Purpose Register 80 Bytes
		0EFh		16Fh		1EFh		26Fh		2EFh		36Fh	
		0F0h	Common RAM (Accesses 70h – 7Fh)	170h	Common RAM (Accesses 70h – 7Fh)	1F0h	Common RAM (Accesses 70h – 7Fh)	270h	Common RAM (Accesses 70h – 7Fh)	2F0h	Common RAM (Accesses 70h – 7Fh)	370h	Common RAM (Accesses 70h – 7Fh)
07Fh	—	0FFh	—	17Fh	—	1FFh	—	27Fh	—	2FFh	—	37Fh	—

Legend: ■ = Unimplemented data memory locations, read as '0'.

TABLE 3-4: PIC16(L)F18876 MEMORY MAP BANK 0-7

BANK 0		BANK 1		BANK 2		BANK 3		BANK 4		BANK 5		BANK 6	
000h	Core Registers (Table 3-2)	080h	Core Registers (Table 3-2)	100h	Core Registers (Table 3-2)	180h	Core Registers (Table 3-2)	200h	Core Registers (Table 3-2)	280h	Core Registers (Table 3-2)	300h	Core Registers (Table 3-2)
00Bh		08Bh		10Bh		18Bh		20Bh		28Bh		30Bh	
00Ch	PORTA	08Ch	ADRESL	10Ch	ADCNT	18Ch	SSP1BUF	20Ch	TMR1L	28Ch	T2TMR	30Ch	CCP1
00Dh	PORTB	08Dh	ADRESH	10Dh	ADRPT	18Dh	SSP1ADD	20Dh	TMR1H	28Dh	T2PR	30Dh	CCP1
00Eh	PORTC	08Eh	ADPREVL	10Eh	ADLTHL	18Eh	SSP1MSK	20Eh	T1CON	28Eh	T2CON	30Eh	CCP1
00Fh	PORTD	08Fh	ADPREVH	10Fh	ADLTHH	18Fh	SSP1STAT	20Fh	T1GCON	28Fh	T2HLT	30Fh	CCP1
010h	PORTE	090h	ADACCL	110h	ADUTHH	190h	SSP1CON1	210h	T1GATE	290h	T2CLKCON	310h	CCP1
011h	TRISA	091h	ADACCH	111h	ADUTHH	191h	SSP1CON2	211h	T1CLK	291h	T2RST	311h	CCP1
012h	TRISB	092h	—	112h	ADSTPTL	192h	SSP1CON3	212h	TMR3L	292h	T4TMR	312h	CCP2
013h	TRISC	093h	ADCON0	113h	ADSTPTH	193h	—	213h	TMR3H	293h	T4PR	313h	CCP2
014h	TRISD	094h	ADCON1	114h	ADFLTRL	194h	—	214h	T3CON	294h	T4CON	314h	CCP2
015h	TRISE	095h	ADCON2	115h	ADFLTRH	195h	—	215h	T3GCON	295h	T4HLT	315h	CCP2
016h	LATA	096h	ADCON3	116h	ADERRL	196h	SSP2BUF	216h	T3GATE	296h	T4CLKCON	316h	CCP3
017h	LATB	097h	ADSTAT	117h	ADERRH	197h	SSP2ADD	217h	T3CLK	297h	T4RST	317h	CCP3
018h	LATC	098h	ADCLK	118h	—	198h	SSP2MSK	218h	TMR5L	298h	T6TMR	318h	CCP3
019h	LATD	099h	ADACT	119h	RC1REG	199h	SSP2STAT	219h	TMR5H	299h	T6PR	319h	CCP3
01Ah	LATE	09Ah	ADREF	11Ah	TX1REG	19Ah	SSP2CON1	21Ah	T5CON	29Ah	T6CON	31Ah	CCP4
01Bh	—	09Bh	ADCAP	11Bh	SP1BRGL	19Bh	SSP2CON2	21Bh	T5GCON	29Bh	T6HLT	31Bh	CCP4
01Ch	TMR0L	09Ch	ADPRE	11Ch	SP1BRGH	19Ch	SSP2CON3	21Ch	T5GATE	29Ch	T6CLKCON	31Ch	CCP4
01Dh	TMR0H	09Dh	ADACQ	11Dh	RC1STA	19Dh	—	21Dh	T5CLK	29Dh	T6RST	31Dh	CCP4
01Eh	T0CON0	09Eh	ADPCH	11Eh	TX1STA	19Eh	—	21Eh	CCPTMRS0	29Eh	—	31Eh	CCP5
01Fh	T0CON1	09Fh	—	11Fh	BAUD1CON	19Fh	—	21Fh	CCPTMRS1	29Fh	—	31Fh	CCP5
020h	General Purpose Register 96 Bytes	0A0h	General Purpose Register 80 Bytes	120h	General Purpose Register 80 Bytes	1A0h	General Purpose Register 80 Bytes	220h	General Purpose Register 80 Bytes	2A0h	General Purpose Register 80 Bytes	320h	General Purpose Register 80 Bytes
0EFh		0EFh		16Fh		1EFh		26Fh		2EFh		36Fh	
0F0h		0F0h	Common RAM (Accesses 70h – 7Fh)	170h	Common RAM (Accesses 70h – 7Fh)	1F0h	Common RAM (Accesses 70h – 7Fh)	270h	Common RAM (Accesses 70h – 7Fh)	2F0h	Common RAM (Accesses 70h – 7Fh)	370h	Common RAM (Accesses 70h – 7Fh)
0FFh		0FFh		17Fh		1FFh		27Fh		2FFh		37Fh	

Legend: ■ = Unimplemented data memory locations, read as '0'.

TABLE 3-5: PIC16F18856/76 MEMORY MAP BANK 8-15

BANK 8		BANK 9		BANK 10		BANK 11		BANK 12		BANK 13		BANK 14	
400h	Core Registers (Table 3-2)	480h	Core Registers (Table 3-2)	500h	Core Registers (Table 3-2)	580h	Core Registers (Table 3-2)	600h	Core Registers (Table 3-2)	680h	Core Registers (Table 3-2)	700h	Core Registers (Table 3-2)
40Bh	SCANLADRL	48Bh	SMT1TMRL	50Bh	SMT2TMRL	58Bh	NCO1ACCL	60Bh	CWG1CLKCON	68Bh	CWG3CLKCON	70Bh	PIR1
40Ch	SCANLADRH	48Ch	SMT1TMRH	50Ch	SMT2TMRH	58Ch	NCO1ACCH	60Ch	CWG1ISM	68Ch	CWG3ISM	70Ch	PIR2
40Dh	SCANHADRL	48Dh	SMT1TMRU	50Dh	SMT2TMRU	58Dh	NCO1ACCU	60Dh	CWG1DBR	68Dh	CWG3DBR	70Dh	PIR3
40Eh	SCANHADRH	48Eh	SMT1CPRH	50Eh	SMT2CPRH	58Eh	NCO1INCL	60Eh	CWG1DBF	68Eh	CWG3DBF	70Eh	PIR4
40Fh	SCANCON0	48Fh	SMT1CPRU	50Fh	SMT2CPRU	58Fh	NCO1INCH	60Fh	CWG1CON0	68Fh	CWG3CON0	70Fh	PIR5
410h	SCANTRIG	490h	SMT1CPRH	510h	SMT2CPRH	590h	NCO1INCU	610h	CWG1CON1	690h	CWG3CON1	710h	PIR6
411h	—	491h	SMT1CPRU	511h	SMT2CPRU	591h	NCO1CON	611h	CWG1CON1	691h	CWG3CON1	711h	PIR7
412h	—	492h	SMT1CPWL	512h	SMT2CPWL	592h	NCO1CON	612h	CWG1AS0	692h	CWG3AS0	712h	PIR8
413h	—	493h	SMT1CPWH	513h	SMT2CPWH	593h	NCO1CLK	613h	CWG1AS1	693h	CWG3AS1	713h	PIR9
414h	—	494h	SMT1CPWU	514h	SMT2CPWU	594h	—	614h	CWG1STR	694h	CWG3STR	714h	PIR10
415h	—	495h	SMT1PRL	515h	SMT2PRL	595h	—	615h	—	695h	—	715h	PIR11
416h	CRCDATL	496h	SMT1PRH	516h	SMT2PRH	596h	—	616h	CWG2CLKCON	696h	—	716h	PIR12
417h	CRCDATAH	497h	SMT1PRU	517h	SMT2PRU	597h	—	617h	CWG2ISM	697h	—	717h	PIR13
418h	CRCACCL	498h	SMT1CON0	518h	SMT2CON0	598h	—	618h	CWG2DBR	698h	—	718h	PIR14
419h	CRCACCH	499h	SMT1CON1	519h	SMT2CON1	599h	—	619h	CWG2DBF	699h	—	719h	PIR15
41Ah	CRCSHIFTL	49Ah	SMT1STAT	51Ah	SMT2STAT	59Ah	—	61Ah	CWG2CON0	69Ah	—	71Ah	PIR16
41Bh	CRCSHIFTH	49Bh	SMT1CLK	51Bh	SMT2CLK	59Bh	—	61Bh	CWG2CON1	69Bh	—	71Bh	PIR17
41Ch	CRCXORL	49Ch	SMT1SIG	51Ch	SMT2SIG	59Ch	—	61Ch	CWG2AS0	69Ch	—	71Ch	PIR18
41Dh	CRCXORH	49Dh	SMT1WIN	51Dh	SMT2WIN	59Dh	—	61Dh	CWG2AS1	69Dh	—	71Dh	PIR19
41Eh	CRCCON0	49Eh	—	51Eh	—	59Eh	—	61Eh	CWG2STR	69Eh	—	71Eh	PIR20
41Fh	CRCCON1	49Fh	—	51Fh	—	59Fh	—	61Fh	—	69Fh	—	71Fh	PIR21
420h	—	4A0h	—	520h	—	5A0h	—	620h	—	6A0h	—	720h	PIR22
46Fh	General Purpose Register 80 Bytes	4EFh	General Purpose Register 80 Bytes	56Fh	General Purpose Register 80 Bytes	5EFh	General Purpose Register 80 Bytes	66Fh	General Purpose Register 80 Bytes	6EFh	General Purpose Register 80 Bytes	76Fh	General Purpose Register 80 Bytes
470h	Common RAM Accesses 70h – 7Fh	4F0h	Common RAM Accesses 70h – 7Fh	570h	Common RAM Accesses 70h – 7Fh	5F0h	Common RAM Accesses 70h – 7Fh	670h	Common RAM Accesses 70h – 7Fh	6F0h	Common RAM Accesses 70h – 7Fh	770h	Common RAM Accesses 70h – 7Fh
47Fh	—	4Fh	—	57Fh	—	5Fh	—	67Fh	—	6Fh	—	77Fh	—

Legend: ■ = Unimplemented data memory locations, read as '0'.

TABLE 3-6: PIC16F18856/76 MEMORY MAP BANK 16-23

BANK 16		BANK 17		BANK 18		BANK 19		BANK 20		BANK 21		BANK 22	
800h	Core Registers (Table 3-2)	880h	Core Registers (Table 3-2)	900h	Core Registers (Table 3-2)	980h	Core Registers (Table 3-2)	A00h	Core Registers (Table 3-2)	A80h	Core Registers (Table 3-2)	B00h	Core Re (Table
80Bh	—	88Bh	—	90Bh	—	98Bh	—	A0Bh	—	A8Bh	—	B0Bh	—
80Ch	WDTCON0	88Ch	CPUDOZE	90Ch	FVRCON	98Ch	—	A0Ch	Unimplemented Read as '0'	A8Ch	Unimplemented Read as '0'	B0Ch	Unimple Read a
80Dh	WDTCON1	88Dh	OSCCON1	90Dh	—	98Dh	—						
80Eh	WDTPSL	88Eh	OSCCON2	90Eh	DAC1CON0	98Eh	—						
80Fh	WDTPSH	88Fh	OSCCON3	90Fh	DAC1CON1	98Fh	CMOUT						
810h	WDTTMR	890h	OSCSTAT	910h	—	990h	CM1CON0						
811h	BORCON	891h	OSCEN	911h	—	991h	CM1CON1						
812h	VREGCON ⁽¹⁾	892h	OSCTUNE	912h	—	992h	CM1NSEL						
813h	PCON0	893h	OSCFRQ	913h	—	993h	CM1PSEL						
814h	CCDCON	894h	—	914h	—	994h	CM2CON0						
815h	—	895h	CLKRCON	915h	—	995h	CM2CON1						
816h	—	896h	CLKRCLK	916h	—	996h	CM2NSEL						
817h	—	897h	MDCON0	917h	—	997h	CM2PSEL						
818h	—	898h	MDCON1	918h	—	998h	—						
819h	—	899h	MDSRC	919h	—	999h	—						
81Ah	NVMADRL	89Ah	MDCARL	91Ah	—	99Ah	—						
81Bh	NVMADRH	89Bh	MDCARH	91Bh	—	99Bh	—						
81Ch	NVMDATL	89Ch	—	91Ch	—	99Ch	—						
81Dh	NVMDATH	89Dh	—	91Dh	—	99Dh	—						
81Eh	NVMCON1	89Eh	—	91Eh	—	99Eh	—						
81Fh	NVMCON2	89Fh	—	91Fh	ZCDCON	99Fh	—						
820h	General Purpose Register 80 Bytes	8A0h	General Purpose Register 80 Bytes	920h	General Purpose Register 80 Bytes	9A0h	General Purpose Register 80 Bytes	A1Fh	General Purpose Register 80 Bytes	A9Fh	General Purpose Register 80 Bytes	B1Fh	Gene Purp Regis 80 By
86Fh	Common RAM Accesses 70h – 7Fh	8EFh	Common RAM Accesses 70h – 7Fh	96Fh	Common RAM Accesses 70h – 7Fh	9EFh	Common RAM Accesses 70h – 7Fh	A20h		Common RAM Accesses 70h – 7Fh		AA0h	
870h		8F0h		970h		9F0h		A70h	AF0h		B70h		
87Fh	8FFh	97Fh	9FFh	A7Fh	AFh	B7Fh							

Legend: ■ = Unimplemented data memory locations, read as '0'.

Note 1: PIC16F18855/75 only.

TABLE 3-7: PIC16(L)F18856/76 MEMORY MAP BANK 24-31

BANK 24		BANK 25		BANK 26		BANK 27		BANK 28		BANK 29		BANK 30	
C00h	Core Registers (Table 3-2)	C80h	Core Registers (Table 3-2)	D00h	Core Registers (Table 3-2)	D80h	Core Registers (Table 3-2)	E00h	Core Registers (Table 3-2)	E80h	Core Registers (Table 3-2)	F00h	Core Registers (Table 3-2)
C0Bh	Unimplemented Read as '0'	C8Bh	Unimplemented Read as '0'	D0Bh	Unimplemented Read as '0'	D8Bh	Unimplemented Read as '0'	E0Bh	See Table 3-8 for register mapping details	E8Bh	See Table 3-9 for register mapping details	F0Bh	See Table 3-10 for register mapping details
C0Ch		C8Ch		D0Ch		D8Ch		E0Ch		E8Ch		F0Ch	
C1Fh		C9Fh		D6Fh		DEFh		E6Fh		EEFh		F6Fh	
C20h	General Purpose Register 80 Bytes	CA0h	General Purpose Register 32 Bytes	D70h	Common RAM Accesses 70h – 7Fh	DF0h	Common RAM Accesses 70h – 7Fh	E70h	Common RAM Accesses 70h – 7Fh	EF0h	Common RAM Accesses 70h – 7Fh	F70h	Common RAM Accesses 70h – 7Fh
C6Fh		CC0h		Unimplemented Read as '0'		D7Fh		DEFh		E7Fh		EEFh	
C70h	Common RAM Accesses 70h – 7Fh	CF0h	Common RAM Accesses 70h – 7Fh	D7Fh	Common RAM Accesses 70h – 7Fh	DFh	Common RAM Accesses 70h – 7Fh	E7Fh	Common RAM Accesses 70h – 7Fh	EFh	Common RAM Accesses 70h – 7Fh	F7Fh	Common RAM Accesses 70h – 7Fh
C7Fh		CFh		D7Fh		DFh		E7Fh		EFh		F7Fh	

Legend: ■ = Unimplemented data memory locations, read as '0'.

PIC16(L)F18856/76

TABLE 3-8: PIC16(L)F18856/76 MEMORY MAP, BANK 28

Bank 28		Bank 28	
E0Ch	—	E2Eh	CLC4CON
E0Dh	—	E2Fh	CLC4POL
E0Eh	—	E30h	CLC4SEL0
E0Fh	CLCDATA	E31h	CLC4SEL1
E10h	CLC1CON	E32h	CLC4SEL2
E11h	CLC1POL	E33h	CLC4SEL3
E12h	CLC1SEL0	E34h	CLC4GLS0
E13h	CLC1SEL1	E35h	CLC4GLS1
E14h	CLC1SEL2	E36h	CLC4GLS2
E15h	CLC1SEL3	E37h	CLC4GLS3
E16h	CLC1GLS0	E38h	—
E17h	CLC1GLS1	E6Fh	—
E18h	CLC1GLS2		
E19h	CLC1GLS3		
E1Ah	CLC2CON		
E1Bh	CLC2POL		
E1Ch	CLC2SEL0		
E1Dh	CLC2SEL1		
E1Eh	CLC2SEL2		
E1Fh	CLC2SEL3		
E20h	CLC2GLS0		
E21h	CLC2GLS1		
E22h	CLC2GLS2		
E23h	CLC2GLS3		
E24h	CLC3CON		
E25h	CLC3POL		
E26h	CLC3SEL0		
E27h	CLC3SEL1		
E28h	CLC3SEL2		
E29h	CLC3SEL3		
E2Ah	CLC3GLS0		
E2Bh	CLC3GLS1		
E2Ch	CLC3GLS2		
E2Dh	CLC3GLS3		

Legend: = Unimplemented data memory locations, read as '0'.

PIC16(L)F18856/76

TABLE 3-9: PIC16(L)F18856/76 MEMORY MAP, BANK 29

Bank 29		Bank 29	
E8Ch	—	EB1h	CWG1PPS
E8Dh	—	EB2h	CWG2PPS
E8Eh	—	EB3h	CWG3PPS
E8Fh	PPSLOCK	EB4h	—
E90h	INTPPS	EB5h	—
E91h	T0CKIPPS	EB6h	—
E92h	T1CKIPPS	EB7h	—
E93h	T1GPPS	EB8h	MDCARLPPS
E94h	T3CKIPPS	EB9h	MDCARHPPS
E95h	T3GPPS	EBAh	MDSRCPPS
E96h	T5CKIPPS	EBBh	CLCIN0PPS
E97h	T5GPPS	EBCh	CLCIN1PPS
E98h	—	EBDh	CLCIN2PPS
E99h	—	EBEh	CLCIN3PPS
E9Ah	—	EBFh	—
E9Bh	—	EC0h	—
E9Ch	T2AINPPS	EC1h	—
E9Dh	T4AINPPS	EC2h	—
E9Eh	T6AINPPS	EC3h	ADCACTPPS
E9Fh	—	EC4h	—
EA0h	—	EC5h	SSP1CLKPPS
EA1h	CCP1PPS	EC6h	SSP1DATPPS
EA2h	CCP2PPS	EC7h	SSP1SSPPS
EA3h	CCP3PPS	EC8h	SSP2CLKPPS
EA4h	CCP4PPS	EC9h	SSP2DATPPS
EA5h	CCP5PPS	ECAh	SSP2SSPPS
EA6h	—	ECBh	RXPPS
EA7h	—	ECCh	TXPPS
EA8h	—	ECDh	—
EA9h	SMT1WINPPS	EEFh	—
EAAh	SMT1SIGPPS		
EABh	SMT2WINPPS		
EACH	SMT2SIGPPS		
EADh	—		
EAEh	—		
EAFh	—		
EB0h	—		

Legend: = Unimplemented data memory locations, read as '0'.

PIC16(L)F18856/76

TABLE 3-10: PIC16(L)F18856 MEMORY MAP, BANK 30

Bank 30		Bank 30	
F0Ch	—	F40h	CCDNA
F0Dh	—	F41h	CCDPA
F0Eh	—	F42h	—
F0Fh	—	F43h	ANSELB
F10h	RA0PPS	F44h	WPUB
F11h	RA1PPS	F45h	ODCONB
F12h	RA2PPS	F46h	SLRCONB
F13h	RA3PPS	F47h	INLVLB
F14h	RA4PPS	F48h	IOCBP
F15h	RA5PPS	F49h	IOCBN
F16h	RA6PPS	F4Ah	IOCBF
F17h	RA7PPS	F4Bh	CCDNB
F18h	RB0PPS	F4Ch	CCDPB
F19h	RB1PPS	F4Dh	—
F1Ah	RB2PPS	F4Eh	ANSELC
F1Bh	RB3PPS	F4Fh	WPUC
F1Ch	RB4PPS	F50h	ODCONC
F1Dh	RB5PPS	F51h	SLRCONC
F1Eh	RB6PPS	F52h	INLVLC
F1Fh	RB7PPS	F53h	IOCCP
F20h	RC0PPS	F54h	IOCCN
F21h	RC1PPS	F55h	IOCCF
F22h	RC2PPS	F56h	CCDNC
F23h	RC3PPS	F57h	CCDPC
F24h	RC4PPS	F58h	—
F25h	RC5PPS	F64h	—
F26h	RC6PPS	F65h	WPUE
F27h	RC7PPS	F66h	—
F28h	—	F67h	—
F37h	—	F68h	INLVLE
F38h	ANSELA	F69h	IOCEP
F39h	WPUA	F6Ah	IOCEN
F3Ah	ODCONA	F6Bh	IOCEF
F3Bh	SLRCONA	F6Ch	—
F3Ch	INLVLA	F6Dh	—
F3Dh	IOCAP	F6Eh	—
F3Eh	IOCAN	F6Fh	—
F3Fh	IOCAF		

Legend: = Unimplemented data memory locations, read as '0'.

PIC16(L)F18856/76

TABLE 3-11: PIC16(L)F18876 MEMORY MAP, BANK 30

Bank 30		Bank 30		Bank 30	
F0Ch	—	F40h	CCDNA	F64h	ANSELE
F0Dh	—	F41h	CCDPA	F65h	WPUE
F0Eh	—	F42h	—	F66h	ODCONE
F0Fh	—	F43h	ANSELB	F67h	SLRCONE
F10h	RA0PPS	F44h	WPUB	F68h	INLVLE
F11h	RA1PPS	F45h	ODCONB	F69h	IOCEP
F12h	RA2PPS	F46h	SLRCONB	F6Ah	IOCEN
F13h	RA3PPS	F47h	INLVLB	F6Bh	IOCEF
F14h	RA4PPS	F48h	IOCBP	F6Ch	CCDNE
F15h	RA5PPS	F49h	IOCBN	F6Dh	CCDPE
F16h	RA6PPS	F4Ah	IOCBF	F6Eh	—
F17h	RA7PPS	F4Bh	CCDNB	F6Fh	—
F18h	RB0PPS	F4Ch	CCDPB		
F19h	RB1PPS	F4Dh	—		
F1Ah	RB2PPS	F4Eh	ANSELC		
F1Bh	RB3PPS	F4Fh	WPUC		
F1Ch	RB4PPS	F50h	ODCONC		
F1Dh	RB5PPS	F51h	SLRCONC		
F1Eh	RB6PPS	F52h	INLVLC		
F1Fh	RB7PPS	F53h	IOCCP		
F20h	RC0PPS	F54h	IOCCN		
F21h	RC1PPS	F55h	IOCCF		
F22h	RC2PPS	F56h	CCDNC		
F23h	RC3PPS	F57h	CCDPC		
F24h	RC4PPS	F58h	—		
F25h	RC5PPS	F59h	ANSELD		
F26h	RC6PPS	F5Ah	WPUD		
F27h	RC7PPS	F5Bh	ODCOND		
F28h	—	F5Ch	SLRCOND		
F37h	—	F5Dh	INLVLD		
F38h	ANSELA	F5Eh	—		
F39h	WPUA	F5Fh	—		
F3Ah	ODCONA	F60h	—		
F3Bh	SLRCONA	F61h	CCDND		
F3Ch	INLVLA	F62h	CCDPD		
F3Dh	IOCAP	F63h	—		
F3Eh	IOCAN				
F3Fh	IOCAF				

Legend: = Unimplemented data memory locations, read as '0'.

PIC16(L)F18856/76

TABLE 3-12: SPECIAL FUNCTION REGISTER SUMMARY BANKS 0-31 (ALL BANKS)

Address	Name	Bit 7	Bit 6	Bit 5	Bit 4	Bit 3	Bit 2	Bit 1	Bit 0	Value on: POR, BOR	Value on all other Resets	
All Banks												
000h	INDF0	Addressing this location uses contents of FSR0H/FSR0L to address data memory (not a physical register)								xxxx xxxx	xxxx xxxx	
001h	INDF1	Addressing this location uses contents of FSR1H/FSR1L to address data memory (not a physical register)								xxxx xxxx	xxxx xxxx	
002h	PCL	Program Counter (PC) Least Significant Byte								0000 0000	0000 0000	
003h	STATUS	—	—	—	\overline{TO}	\overline{PD}	Z	DC	C	---1 1000	---q quuu	
004h	FSR0L	Indirect Data Memory Address 0 Low Pointer								0000 0000	uuuu uuuu	
005h	FSR0H	Indirect Data Memory Address 0 High Pointer								0000 0000	0000 0000	
006h	FSR1L	Indirect Data Memory Address 1 Low Pointer								0000 0000	uuuu uuuu	
007h	FSR1H	Indirect Data Memory Address 1 High Pointer								0000 0000	0000 0000	
008h	BSR	—	—	—	BSR4	BSR3	BSR2	BSR1	BSR0	---0 0000	---0 0000	
009h	WREG	Working Register								0000 0000	uuuu uuuu	
00Ah	PCLATH	—	Write Buffer for the upper 7 bits of the Program Counter								-000 0000	-000 0000
00Bh	INTCON	GIE	PEIE	—	—	—	—	—	INTEDG	00-- ---1	00-- ---1	

Legend: x = unknown, u = unchanged, q = depends on condition, - = unimplemented, read as '0', r = reserved. Shaded locations unimplemented, read as '0'.

Note 1: These Registers can be accessed from any bank

TABLE 3-13: SPECIAL FUNCTION REGISTER SUMMARY BANKS 0-31

Address	Name	PIC16(L)/F18856	PIC16(L)/F18876	Bit 7	Bit 6	Bit 5	Bit 4	Bit 3	Bit 2	Bit 1	Bit 0
Bank 0											
CPU CORE REGISTERS; see Table 3-2 for specifics											
00Ch	PORTA			RA7	RA6	RA5	RA4	RA3	RA2	RA1	RA0
00Dh	PORTB			RB7	RB6	RB5	RB4	RB3	RB2	RB1	RB0
00Eh	PORTC			RC7	RC6	RC5	RC4	RC3	RC2	RC1	RC0
00Fh	PORTD	X	—	Unimplemented							
		—	X	RD7	RD6	RD5	RD4	RD3	RD2	RD1	RD0
010h	PORTE	X	—	—	—	—	—	RE3	—	—	—
		—	X	—	—	—	—	RE3	RE2	RE1	RE0
011h	TRISA			TRISA7	TRISA6	TRISA5	TRISA4	TRISA3	TRISA2	TRISA1	TRISA0
012h	TRISB			TRISB7	TRISB6	TRISB5	TRISB4	TRISB3	TRISB2	TRISB1	TRISB0
013h	TRISC			TRISC7	TRISC6	TRISC5	TRISC4	TRISC3	TRISC2	TRISC1	TRISC0
014h	TRISD	X	—	Unimplemented							
		—	X	TRISD7	TRISD6	TRISD5	TRISD4	TRISD3	TRISD2	TRISD1	TRISD0
015h	TRISE	X	—	Unimplemented							
		—	X	—	—	—	—	—	TRISE2	TRISE1	TRISE0
016h	LATA			LATA7	LATA6	LATA5	LATA4	LATA3	LATA2	LATA1	LATA0
017h	LATB			LATB7	LATB6	LATB5	LATB4	LATB3	LATB2	LATB1	LATB0
018h	LATC			LATC7	LATC6	LATC5	LATC4	LATC3	LATC2	LATC1	LATC0
019h	LATD	X	—	Unimplemented							
		—	X	LATD7	LATD6	LATD5	LATD4	LATD3	LATD2	LATD1	LATD0
01Ah	LATE	X	—	Unimplemented							
		—	X	—	—	—	—	—	LATE2	LATE1	LATE0

Legend: x = unknown, u = unchanged, c = depends on condition, - = unimplemented, read as '0', r = reserved. Shaded locations unimplemented, read as '0'.

Note 1: Register present on PIC16F18855/75 devices only.

Note 2: Unimplemented, read as '1'.

TABLE 3-13: SPECIAL FUNCTION REGISTER SUMMARY BANKS 0-31 (CONTINUED)

Address	Name	PIC16(L)F18856	PIC16(L)F18876	Bit 7	Bit 6	Bit 5	Bit 4	Bit 3	Bit 2	Bit 1	Bit 0
Bank 0 (Continued)											
01Bh	—	—	—	Unimplemented							
01Ch	TMR0L			Holding Register for the Least Significant Byte of the 16-bit TMR0 Register							
01Dh	TMR0H			Holding Register for the Most Significant Byte of the 16-bit TMR0 Register							
01Eh	T0CON0			T0EN	—	T0OUT	T016BIT	T0OUTPS<3:0>			
01Fh	T0CON1			T0CS<2:0>			T0ASYNC	T0CKPS<3:0>			

Legend: x = unknown, u = unchanged, c = depends on condition, - = unimplemented, read as '0', r = reserved. Shaded locations unimplemented, read as '0'.

Note 1: Register present on PIC16F18855/75 devices only.

2: Unimplemented, read as '1'.

TABLE 3-13: SPECIAL FUNCTION REGISTER SUMMARY BANKS 0-31 (CONTINUED)

Address	Name	PIC16(L)/F18856	PIC16(L)/F18876	Bit 7	Bit 6	Bit 5	Bit 4	Bit 3	Bit 2	Bit 1	Bit 0
Bank 1											
CPU CORE REGISTERS; see Table 3-2 for specifics											
08Ch	ADRESL			ADRESL<7:0>							
08Dh	ADRESH			ADRESH<7:0>							
08Eh	ADPREVL			ADPREVL<7:0>							
08Fh	ADPREVH			ADPREVH<7:0>							
090h	ADACCL			ADACCL<7:0>							
091h	ADACCH			ADACCH<7:0>							
092h	—	—		Unimplemented							
093h	ADCON0			ADON	ADCONT	—	ADCS	—	ADFRM0	—	ADGO
094h	ADCON1			ADPPOL	ADIPEN	ADGPOL	—	—	—	—	ADDSN
095h	ADCON2			ADPSIS	ADCRS<2:0>			ADACL	ADMD<2:0>		
096h	ADCON3			—	ADCALC<2:0>			ADSOI	ADTMD<2:0>		
097h	ADSTAT			ADAOV	ADUTHR	ADLTHR	ADMATH	—	ADSTAT<2:0>		
098h	ADCLK			—	—	ADCCS<5:0>					
099h	ADACT			—	—	—	ADACT<4:0>				
09Ah	ADREF			—	—	—	ADNREF	—	—	ADPREF<1:0>	
09Bh	ADCAP			—	—	—	ADCAP<4:0>				
09Ch	ADPRE			ADPRE<7:0>							
09Dh	ADACQ			ADACQ<7:0>							
09Eh	ADPCH			—	—	ADPCH<5:0>					
09Fh	—	—		Unimplemented							

Legend: x = unknown, u = unchanged, c = depends on condition, - = unimplemented, read as '0', r = reserved. Shaded locations unimplemented, read as '0'.

Note 1: Register present on PIC16F18855/75 devices only.

Note 2: Unimplemented, read as '1'.

TABLE 3-13: SPECIAL FUNCTION REGISTER SUMMARY BANKS 0-31 (CONTINUED)

Address	Name	PIC16(L)/F18856	PIC16(L)/F18876	Bit 7	Bit 6	Bit 5	Bit 4	Bit 3	Bit 2	Bit 1	Bit 0
Bank 2											
CPU CORE REGISTERS; see Table 3-2 for specifics											
10Ch	ADCNT										ADCNT<7:0>
10Dh	ADRPT										ADRPT<7:0>
10Eh	ADLTHL										ADLTH<7:0>
10Fh	ADLTHH										ADLTH<15:8>
110h	ADUTHL										ADUTH<7:0>
111h	ADUTHH										ADUTH<15:8>
112h	ADSTPTL										ADSTPT<7:0>
113h	ADSTPTH										ADSTPT<15:8>
114h	ADFLTRL										ADFLTR<7:0>
115h	ADFLTRH										ADFLTR<15:8>
116h	ADERRL										ADERR<7:0>
117h	ADERRH										ADERR<15:8>
118h	—	—									Unimplemented
119h	RC1REG										RC1REG<7:0>
11Ah	TX1REG										TX1REG<7:0>
11Bh	SP1BRGL										SP1BRGL<7:0>
11Ch	SP1BRGH										SP1BRGH<7:0>
11Dh	RC1STA			SPEN	RX9	SREN	CREN	ADDEN	FERR	OERR	RX9D
11Eh	TX1STA			CSRC	TX9	TXEN	SYNC	SENDB	BRGH	TRMT	TX9D
11Fh	BAUD1CON			ABDOVF	RCIDL	—	SCKP	BRG16	—	WUE	ABDEN

Legend: x = unknown, u = unchanged, c = depends on condition, - = unimplemented, read as '0', r = reserved. Shaded locations unimplemented, read as '0'.

Note 1: Register present on PIC16F18855/75 devices only.

Note 2: Unimplemented, read as '1'.

TABLE 3-13: SPECIAL FUNCTION REGISTER SUMMARY BANKS 0-31 (CONTINUED)

Address	Name	PIC16(L)F18856	PIC16(L)F18876	Bit 7	Bit 6	Bit 5	Bit 4	Bit 3	Bit 2	Bit 1	Bit 0
Bank 3											
CPU CORE REGISTERS; see Table 3-2 for specifics											
18Ch	SSP1BUF			SSPBUF<7:0>							
18Dh	SSP1ADD			SSPADD<7:0>							
18Eh	SSP1MSK			SSPMSK<7:0>							
18Fh	SSP1STAT			SMP	CKE	D/A	P	S	R/W	UA	BF
190h	SSP1CON1			WCOL	SSPOV	SSPEN	CKP	SSPM<3:0>			
191h	SSP1CON2			GCEN	ACKSTAT	ACKDT	ACKEN	RCEN	PEN	RSEN	SEN
192h	SSP1CON3			ACKTIM	PCIE	SCIE	BOEN	SDAHT	SBCDE	AHEN	DHEN
193h	—	—	—	Unimplemented							
194h	—	—	—	Unimplemented							
195h	—	—	—	Unimplemented							
196h	SSP2BUF			SSPBUF<7:0>							
197h	SSP2ADD			SSPADD<7:0>							
198h	SSP2MSK			SSPMSK<7:0>							
199h	SSP2STAT			SMP	CKE	D/A	P	S	R/W	UA	BF
19Ah	SSP2CON1			WCOL	SSPOV	SSPEN	CKP	SSPM<3:0>			
19Bh	SSP2CON2			GCEN	ACKSTAT	ACKDT	ACKEN	RCEN	PEN	RSEN	SEN
19Ch	SSP2CON3			ACKTIM	PCIE	SCIE	BOEN	SDAHT	SBCDE	AHEN	DHEN
19Dh	—	—	—	Unimplemented							
19Eh	—	—	—	Unimplemented							
19Fh	—	—	—	Unimplemented							

Legend: x = unknown, u = unchanged, c = depends on condition, - = unimplemented, read as '0', r = reserved. Shaded locations unimplemented, read as '0'.

Note 1: Register present on PIC16F18855/75 devices only.

Note 2: Unimplemented, read as '1'.

TABLE 3-13: SPECIAL FUNCTION REGISTER SUMMARY BANKS 0-31 (CONTINUED)

Address	Name	PIC16(L)/F18856	PIC16(L)/F18876	Bit 7	Bit 6	Bit 5	Bit 4	Bit 3	Bit 2	Bit 1	Bit 0
Bank 4											
CPU CORE REGISTERS; see Table 3-2 for specifics											
20Ch	TMR1L			Holding Register for the Least Significant Byte of the 16-bit TMR1 Register							
20Dh	TMR1H			Holding Register for the Most Significant Byte of the 16-bit TMR1 Register							
20Eh	T1CON			—	—	CKPS<1:0>		—	SYNC	RD16	ON
20Fh	T1GCON			GE	GPOL	GTM	GSPM	GGO/DONE	GVAL	—	—
210h	T1GATE			—	—	—	GSS<4:0>				
211h	T1CLK			—	—	—	—	CS<3:0>			
212h	TMR3L			Holding Register for the Least Significant Byte of the 16-bit TMR3 Register							
213h	TMR3H			Holding Register for the Most Significant Byte of the 16-bit TMR3 Register							
214h	T3CON			—	—	CKPS<1:0>		—	SYNC	RD16	ON
215h	T3GCON			GE	GPOL	GTM	GSPM	GGO/DONE	GVAL	—	—
216h	T3GATE			—	—	—	GSS<4:0>				
217h	T3CLK			—	—	—	—	CS<3:0>			
218h	TMR5L			Holding Register for the Least Significant Byte of the 16-bit TMR5 Register							
219h	TMR5H			Holding Register for the Most Significant Byte of the 16-bit TMR5 Register							
21Ah	T5CON			—	—	CKPS<1:0>		—	SYNC	RD16	ON
21Bh	T5GCON			GE	GPOL	GTM	GSPM	GGO/DONE	GVAL	—	—
21Ch	T5GATE			—	—	—	GSS<4:0>				
21Dh	T5CLK			—	—	—	—	CS<3:0>			
21Eh	CCPTMRS0			C4TSEL<1:0>		C3TSEL<1:0>		C2TSEL<1:0>		C1TSEL<1:0>	
21Fh	CCPTMRS1			—	—	P7TSEL<1:0>		P6TSEL<1:0>		C5TSEL<1:0>	

Legend: x = unknown, u = unchanged, q = depends on condition, - = unimplemented, read as '0', r = reserved. Shaded locations unimplemented, read as '0'.

Note 1: Register present on PIC16F18855/75 devices only.

Note 2: Unimplemented, read as '1'.

TABLE 3-13: SPECIAL FUNCTION REGISTER SUMMARY BANKS 0-31 (CONTINUED)

Address	Name	PIC16(L)/F18856	PIC16(L)/F18876	Bit 7	Bit 6	Bit 5	Bit 4	Bit 3	Bit 2	Bit 1	Bit 0
Bank 5											
CPU CORE REGISTERS; see Table 3-2 for specifics											
28Ch	T2TMR			Holding Register for the 8-bit TMR2 Register							
28Dh	T2PR			TMR2 Period Register							
28Eh	T2CON			ON	CKPS<2:0>			OUTPS<3:0>			
28Fh	T2HLT			PSYNC	CKPOL	CKSYNC	—	MODE			
290h	T2CLKCON			—	—	—	—	—	CS<2:0>		
291h	T2RST			—	—	—	RSEL<4:0>				
292h	T4TMR			Holding Register for the 8-bit TMR4 Register							
293h	T4PR			TMR4 Period Register							
294h	T4CON			ON	CKPS<2:0>			OUTPS<3:0>			
295h	T4HLT			PSYNC	CKPOL	CKSYNC	—	MODE<3:0>			
296h	T4CLKCON			—	—	—	—	—	CS<2:0>		
297h	T4RST			—	—	—	RSEL<4:0>				
298h	T6TMR			Holding Register for the 8-bit TMR6 Register							
299h	T6PR			TMR6 Period Register							
29Ah	T6CON			ON	CKPS<2:0>			OUTPS<3:0>			
29Bh	T6HLT			PSYNC	CKPOL	CKSYNC	—	MODE<3:0>			
29Ch	T6CLKCON			—	—	—	—	—	CS<2:0>		
29Dh	T6RST			—	—	—	RSEL<4:0>				
29Eh	—	—	—	Unimplemented							
29Fh	—	—	—	Unimplemented							

Legend: x = unknown, u = unchanged, c = depends on condition, - = unimplemented, read as '0', r = reserved. Shaded locations unimplemented, read as '0'.

Note 1: Register present on PIC16F18855/75 devices only.

Note 2: Unimplemented, read as '1'.

TABLE 3-13: SPECIAL FUNCTION REGISTER SUMMARY BANKS 0-31 (CONTINUED)

Address	Name	PIC16(L)/F18856	PIC16(L)/F18876	Bit 7	Bit 6	Bit 5	Bit 4	Bit 3	Bit 2	Bit 1	Bit 0
Bank 6											
CPU CORE REGISTERS; see Table 3-2 for specifics											
30Ch	CCPR1L			Capture/Compare/PWM Register 1 (LSB)							
30Dh	CCPR1H			Capture/Compare/PWM Register 1 (MSB)							
30Eh	CCP1CON			EN	—	OUT	FMT	MODE<3:0>			
30Fh	CCP1CAP			—	—	—	—	—	CTS<2:0>		
310h	CCPR2L			Capture/Compare/PWM Register 2 (LSB)							
311h	CCPR2H			Capture/Compare/PWM Register 2 (MSB)							
312h	CCP2CON			EN	—	OUT	FMT	MODE<3:0>			
313h	CCP2CAP			—	—	—	—	—	CTS<2:0>		
314h	CCPR3L			Capture/Compare/PWM Register 3 (LSB)							
315h	CCPR3H			Capture/Compare/PWM Register 3 (MSB)							
316h	CCP3CON			EN	—	OUT	FMT	MODE<3:0>			
317h	CCP3CAP			—	—	—	—	CTS<3:0>			
318h	CCPR4L			Capture/Compare/PWM Register 4 (LSB)							
319h	CCPR4H			Capture/Compare/PWM Register 4 (MSB)							
31Ah	CCP4CON			EN	—	OUT	FMT	MODE<3:0>			
31Bh	CCP4CAP			—	—	—	—	CTS<3:0>			
31Ch	CCPR5L			Capture/Compare/PWM Register 5 (LSB)							
31Dh	CCPR5H			Capture/Compare/PWM Register 5 (MSB)							
31Eh	CCP5CON			EN	—	OUT	FMT	MODE<3:0>			
31Fh	CCP5CAP			—	—	—	—	CTS<3:0>			

Legend: x = unknown, u = unchanged, c = depends on condition, - = unimplemented, read as '0', r = reserved. Shaded locations unimplemented, read as '0'.

Note 1: Register present on PIC16F18855/75 devices only.

Note 2: Unimplemented, read as '1'.

TABLE 3-13: SPECIAL FUNCTION REGISTER SUMMARY BANKS 0-31 (CONTINUED)

Address	Name	PIC16(L)/F18856	PIC16(L)/F18876	Bit 7	Bit 6	Bit 5	Bit 4	Bit 3	Bit 2	Bit 1	Bit 0
Bank 7											
CPU CORE REGISTERS; see Table 3-2 for specifics											
38Ch	PWM6DCL			DC<1:0>	—	—	—	—	—	—	—
38Dh	PWM6DCH			DC<9:2>							
38Eh	PWM6CON			EN	—	OUT	POL	—	—	—	—
38Fh	—	—		Unimplemented							
390h	PWM7DCL			DC<1:0>	—	—	—	—	—	—	—
391h	PWM7DCH			DC<9:2>							
392h	PWM7CON			EN	—	OUT	POL	—	—	—	—
393h	—	—		Unimplemented							
394h	—	—		Unimplemented							
395h	—	—		Unimplemented							
396h	—	—		Unimplemented							
397h	—	—		Unimplemented							
398h	—	—		Unimplemented							
399h	—	—		Unimplemented							
39Ah	—	—		Unimplemented							
39Bh	—	—		Unimplemented							
39Ch	—	—		Unimplemented							
39Dh	—	—		Unimplemented							
39Eh	—	—		Unimplemented							
39Fh	—	—		Unimplemented							

Legend: x = unknown, u = unchanged, c = depends on condition, - = unimplemented, read as '0', r = reserved. Shaded locations unimplemented, read as '0'.

Note 1: Register present on PIC16F18855/75 devices only.

Note 2: Unimplemented, read as '1'.

TABLE 3-13: SPECIAL FUNCTION REGISTER SUMMARY BANKS 0-31 (CONTINUED)

Address	Name	PIC16(L)/F18856	PIC16(L)/F18876	Bit 7	Bit 6	Bit 5	Bit 4	Bit 3	Bit 2	Bit 1	Bit 0	
Bank 8												
CPU CORE REGISTERS; see Table 3-2 for specifics												
40Ch	SCANLADRL										LADR<7:0>	
40Dh	SCANLADRH										LADR<15:8>	
40Eh	SCANHADRL										HADR<7:0>	
40Fh	SCANHADRH										HADR<15:8>	
410h	SCANCON0			EN	SCANGO	BUSY	INVALID	INTM	—	MODE<1:0>		
411h	SCANTRIG			—	—	—	—	TSEL<3:0>				
412h	—	—	—								Unimplemented	
413h	—	—	—								Unimplemented	
414h	—	—	—								Unimplemented	
415h	—	—	—								Unimplemented	
416h	CRCDATL										DATA<7:0>	
417h	CRCDATH										DATA<15:8>	
418h	CRCACCL										ACC<7:0>	
419h	CRCACCH										ACC<15:8>	
41Ah	CRCSHIFTL										SHIFT<7:0>	
41Bh	CRCSHIFTH										SHIFT<15:8>	
41Ch	CRCXORL										X<7:1>	
41Dh	CRCXORH										X<15:8>	
41Eh	CRCCON0			EN	CRCGO	BUSY	ACCM	—	—	SHIFTM	FULL	
41Fh	CRCCON1			DLEN<3:0>				PLEN<3:0>				

Legend: x = unknown, u = unchanged, c = depends on condition, - = unimplemented, read as '0', r = reserved. Shaded locations unimplemented, read as '0'.

Note 1: Register present on PIC16F18855/75 devices only.

Note 2: Unimplemented, read as '1'.

TABLE 3-13: SPECIAL FUNCTION REGISTER SUMMARY BANKS 0-31 (CONTINUED)

Address	Name	PIC16(L)/F18856	PIC16(L)/F18876	Bit 7	Bit 6	Bit 5	Bit 4	Bit 3	Bit 2	Bit 1	Bit 0
Bank 9											
CPU CORE REGISTERS; see Table 3-2 for specifics											
48Ch	SMT1TMRL			TMR<7:0>							
48Dh	SMT1TMRH			TMR<15:8>							
48Eh	SMT1TMRU			TMR<23:16>							
48Fh	SMT1CPRL			CPR<7:0>							
490h	SMT1CPRH			CPR<15:8>							
491h	SMT1CPRU			CPR<23:16>							
492h	SMT1CPWL			CPW<7:0>							
493h	SMT1CPWH			CPW<15:8>							
494h	SMT1CPWU			CPW<23:16>							
495h	SMT1PRL			PR<7:0>							
496h	SMT1PRH			PR<15:8>							
497h	SMT1PRU			PR<23:16>							
498h	SMT1CON0			EN	—	STP	WPOL	SPOL	CPOL	SMT1PS<1:0>	
499h	SMT1CON1			SMT1GO	REPEAT	—	—	MODE<3:0>			
49Ah	SMT1STAT			CPRUP	CPWUP	RST	—	—	TS	WS	AS
49Bh	SMT1CLK			—	—	—	—	—	CSEL<2:0>		
49Ch	SMT1SIG			—	—	—	SSEL<4:0>				
49Dh	SMT1WIN			—	—	—	WSEL<4:0>				
49Eh	—	—	—	Unimplemented							
49Fh	—	—	—	Unimplemented							

Legend: x = unknown, u = unchanged, q = depends on condition, - = unimplemented, read as '0', r = reserved. Shaded locations unimplemented, read as '0'.

Note 1: Register present on PIC16F18855/75 devices only.

Note 2: Unimplemented, read as '1'.

TABLE 3-13: SPECIAL FUNCTION REGISTER SUMMARY BANKS 0-31 (CONTINUED)

Address	Name	PIC16(L)/F18856	PIC16(L)/F18876	Bit 7	Bit 6	Bit 5	Bit 4	Bit 3	Bit 2	Bit 1	Bit 0
Bank 10											
50Ch	SMT2TMRL							TMR<7:0>			
50Dh	SMT2TMRH							TMR<15:8>			
50Eh	SMT2TMRU							TMR<23:16>			
50Fh	SMT2CPRL							CPR<7:0>			
510h	SMT2CPRH							CPR<15:8>			
511h	SMT2CPRU							CPR<23:16>			
512h	SMT2CPWL							CPW<7:0>			
513h	SMT2CPWH							CPW<15:8>			
514h	SMT2CPWU							CPW<23:16>			
515h	SMT2PRL							PR<7:0>			
516h	SMT2PRH							PR<15:8>			
517h	SMT2PRU							PR<23:16>			
518h	SMT2CON0			EN	—	STP	WPOL	SPOL	CPOL	SMT2PS<1:0>	
519h	SMT2CON1			SMT2GO	REPEAT	—	—	MODE<3:0>			
51Ah	SMT2STAT			CPRUP	CPWUP	RST	—	—	TS	WS	AS
51Bh	SMT2CLK			—	—	—	—	—	CSEL<2:0>		
51Ch	SMT2SIG			—	—	—	SSEL<4:0>				
51Dh	SMT2WIN			—	—	—	WSEL<4:0>				
51Eh	—	—	—	Unimplemented							
51Fh	—	—	—	Unimplemented							

Legend: x = unknown, u = unchanged, c = depends on condition, - = unimplemented, read as '0', r = reserved. Shaded locations unimplemented, read as '0'.

Note 1: Register present on PIC16F18855/75 devices only.

2: Unimplemented, read as '1'.

TABLE 3-13: SPECIAL FUNCTION REGISTER SUMMARY BANKS 0-31 (CONTINUED)

Address	Name	PIC16(L)/F18856	PIC16(L)/F18876	Bit 7	Bit 6	Bit 5	Bit 4	Bit 3	Bit 2	Bit 1	Bit 0	
Bank 11												
CPU CORE REGISTERS; see Table 3-2 for specifics												
58Ch	NCO1ACCL			NCO1ACC<7:0>								
58Dh	NCO1ACCH			NCO1ACC<15:8>								
58Eh	NCO1ACCU			—	—	—	—	NCO1ACC<19:16>				
58Fh	NCO1INCL			NCO1INC<7:0>								
590h	NCO1INCH			NCO1INC<15:8>								
591h	NCO1INCU			—	—	—	—	NCO1INC<19:16>				
592h	NCO1CON			N1EN	—	N1OUT	N1POL	—	—	—	N1PFM	
593h	NCO1CLK			N1PWS<2:0>			—	—	N1CKS<2:0>			
594h	—	—	—	Unimplemented								
595h	—	—	—	Unimplemented								
596h	—	—	—	Unimplemented								
597h	—	—	—	Unimplemented								
598h	—	—	—	Unimplemented								
599h	—	—	—	Unimplemented								
59Ah	—	—	—	Unimplemented								
59Bh	—	—	—	Unimplemented								
59Ch	—	—	—	Unimplemented								
59Dh	—	—	—	Unimplemented								
59Eh	—	—	—	Unimplemented								
59Fh	—	—	—	Unimplemented								

Legend: x = unknown, u = unchanged, c = depends on condition, - = unimplemented, read as '0', r = reserved. Shaded locations unimplemented, read as '0'.

Note 1: Register present on PIC16F18855/75 devices only.

Note 2: Unimplemented, read as '1'.

TABLE 3-13: SPECIAL FUNCTION REGISTER SUMMARY BANKS 0-31 (CONTINUED)

Address	Name	PIC16(L)/F18856	PIC16(L)/F18876	Bit 7	Bit 6	Bit 5	Bit 4	Bit 3	Bit 2	Bit 1	Bit 0
Banks 12											
CPU CORE REGISTERS; see Table 3-2 for specifics											
60Ch	CWG1CLKCON			—	—	—	—	—	—	—	CS
60Dh	CWG1ISM			—	—	—	—	IS<3:0>			
60Eh	CWG1DBR			—	—	DBR<5:0>					
60Fh	CWG1DBF			—	—	DBF<5:0>					
610h	CWG1CON0			EN	LD	—	—	—	MODE<2:0>		
611h	CWG1CON1			—	—	IN	—	POLD	POLC	POLB	POLA
612h	CWG1AS0			SHUTDOWN	REN	LSBD<1:0>		LSAC<1:0>		—	—
613h	CWG1AS1			—	AS6E	AS5E	AS4E	AS3E	AS2E	AS1E	AS0E
614h	CWG1STR			OVRD	OVRC	OVRB	OVRA	STRD	STRC	STRB	STRA
615h	—	—		Unimplemented							
616h	CWG2CLKCON			—	—	—	—	—	—	—	CS
617h	CWG2ISM			—	—	—	—	IS<3:0>			
618h	CWG2DBR			—	—	DBR<5:0>					
619h	CWG2DBF			—	—	DBF<5:0>					
61Ah	CWG2CON0			EN	LD	—	—	—	MODE<2:0>		
61Bh	CWG2CON1			—	—	IN	—	POLD	POLC	POLB	POLA
61Ch	CWG2AS0			SHUTDOWN	REN	LSBD<1:0>		LSAC<1:0>		—	—
61Dh	CWG2AS1			—	AS6E	AS5E	AS4E	AS3E	AS2E	AS1E	AS0E
61Eh	CWG2STR			OVRD	OVRC	OVRB	OVRA	STRD	STRC	STRB	STRA
61Fh	—	—		Unimplemented							

Legend: x = unknown, u = unchanged, q = depends on condition, - = unimplemented, read as '0', r = reserved. Shaded locations unimplemented, read as '0'.

Note 1: Register present on PIC16F18855/75 devices only.

Note 2: Unimplemented, read as '1'.

TABLE 3-13: SPECIAL FUNCTION REGISTER SUMMARY BANKS 0-31 (CONTINUED)

Address	Name	PIC16(L)/F18856	PIC16(L)/F18876	Bit 7	Bit 6	Bit 5	Bit 4	Bit 3	Bit 2	Bit 1	Bit 0
Bank 13											
CPU CORE REGISTERS; see Table 3-2 for specifics											
68Ch	CWG3CLKCON			—	—	—	—	—	—	—	CS
68Dh	CWG3ISM			—	—	—	—	IS<3:0>			
68Eh	CWG3DBR			—	—	DBR<5:0>					
68Fh	CWG3DBF			—	—	DBF<5:0>					
690h	CWG3CON0			EN	LD	—	—	—	MODE<2:0>		
691h	CWG3CON1			—	—	IN	—	POLD	POLC	POLB	POLA
692h	CWG3AS0			SHUTDOWN	REN	LSBD<1:0>		LSAC<1:0>			—
693h	CWG3AS1			—	AS6E	AS5E	AS4E	AS3E	AS2E	AS1E	AS0E
694h	CWG3STR			OVRD	OVRC	OVRB	OVRA	STRD	STRC	STRB	STRA
695h	—	—	—	Unimplemented							
696h	—	—	—	Unimplemented							
697h	—	—	—	Unimplemented							
698h	—	—	—	Unimplemented							
699h	—	—	—	Unimplemented							
69Ah	—	—	—	Unimplemented							
69Bh	—	—	—	Unimplemented							
69Ch	—	—	—	Unimplemented							
69Dh	—	—	—	Unimplemented							
69Eh	—	—	—	Unimplemented							
69Fh	—	—	—	Unimplemented							

Legend: x = unknown, u = unchanged, c = depends on condition, - = unimplemented, read as '0', r = reserved. Shaded locations unimplemented, read as '0'.

Note 1: Register present on PIC16F18855/75 devices only.

Note 2: Unimplemented, read as '1'.

TABLE 3-13: SPECIAL FUNCTION REGISTER SUMMARY BANKS 0-31 (CONTINUED)

Address	Name	PIC16(L)/F18856	PIC16(L)/F18876	Bit 7	Bit 6	Bit 5	Bit 4	Bit 3	Bit 2	Bit 1	Bit 0
Bank 14											
CPU CORE REGISTERS; see Table 3-2 for specifics											
70Ch	PIR0			—	—	TMR0IF	IOCIF	—	—	—	INTF
70Dh	PIR1			OSFIF	CSWIF	—	—	—	—	ADTIF	ADIF
70Eh	PIR2			—	ZCDIF	—	—	—	—	C2IF	C1IF
70Fh	PIR3			—	—	RCIF	TXIF	BCL2IF	SSP2IF	BCL1IF	SSP1IF
710h	PIR4			—	—	TMR6IF	TMR5IF	TMR4IF	TMR3IF	TMR2IF	TMR1IF
711h	PIR5			CLC4IF	CLC3IF	CLC2IF	CLC1IF	—	TMR5GIF	TMR3GIF	TMR1GIF
712h	PIR6			—	—	—	CCP5IF	CCP4IF	CCP3IF	CCP2IF	CCP1IF
713h	PIR7			SCANIF	CRCIF	NVMIF	NCO1IF	—	CWG3IF	CWG2IF	CWG1IF
714h	PIR8			—	—	SMT2PWAIF	SMT2PRAIF	SMT2IF	SMT1PWAIF	SMT1PRAIF	SMT1IF
715h	—	—		Unimplemented							
716h	PIE0			—	—	TMR0IE	IOCIE	—	—	—	INTE
717h	PIE1			OSFIE	CSWIE	—	—	—	—	ADTIE	ADIE
718h	PIE2			—	ZCDIE	—	—	—	—	C2IE	C1IE
719h	PIE3			—	—	RCIE	TXIE	BCL2IE	SSP2IE	BCL1IE	SSP1IE
71Ah	PIE4			—	—	TMR6IE	TMR5IE	TMR4IE	TMR3IE	TMR2IE	TMR1IE
71Bh	PIE5			CLC4IE	CLC3IE	CLC2IE	CLC1IE	—	TMR5GIE	TMR3GIE	TMR1GIE
71Ch	PIE6			—	—	—	CCP5IE	CCP4IE	CCP3IE	CCP2IE	CCP1IE
71Dh	PIE7			SCANIE	CRCIE	NVMIE	NCO1IE	—	CWG3IE	CWG2IE	CWG1IE
71Eh	PIE8			—	—	SMT2PWAIE	SMT2PRAIE	SMT2IE	SMT1PWAIE	SMT1PRAIE	SMT1IE
71Fh	—	—		Unimplemented							

Legend: x = unknown, u = unchanged, q = depends on condition, - = unimplemented, read as '0', r = reserved. Shaded locations unimplemented, read as '0'.

Note 1: Register present on PIC16F18855/75 devices only.

Note 2: Unimplemented, read as '1'.

TABLE 3-13: SPECIAL FUNCTION REGISTER SUMMARY BANKS 0-31 (CONTINUED)

Address	Name	PIC16(L)/F18856	PIC16(L)/F18876	Bit 7	Bit 6	Bit 5	Bit 4	Bit 3	Bit 2	Bit 1	Bit 0
Banks 15											
CPU CORE REGISTERS; see Table 3-2 for specifics											
78Ch	—	—	—	Unimplemented							
78Dh	—	—	—	Unimplemented							
78Eh	—	—	—	Unimplemented							
78Fh	—	—	—	Unimplemented							
790h	—	—	—	Unimplemented							
791h	—	—	—	Unimplemented							
792h	—	—	—	Unimplemented							
793h	—	—	—	Unimplemented							
794h	—	—	—	Unimplemented							
795h	—	—	—	Unimplemented							
796h	PMD0			SYSCMD	FVRMD	—	CRCMD	SCANMD	NVMMD	CLKRMD	IOCMD
797h	PMD1			NCOMD	TMR6MD	TMR5MD	TMR4MD	TMR3MD	TMR2MD	TMR1MD	TMR0MD
798h	PMD2			—	DACMD	ADCMD	—	—	CMP2MD	CMP1MD	ZCDMD
799h	PMD3			—	PWM7MD	PWM6MD	CCP5MD	CCP4MD	CCP3MD	CCP2MD	CCP1MD
79Ah	PMD4			—	UART1MD	MSSP2MD	MSSP1MD	—	CWG3MD	CWG2MD	CWG1MD
79Bh	PMD5			SMT2MD	SMT1MD	—	CLC4MD	CLC3MD	CLC2MD	CLC1MD	DSMMD
79Ch	—	—	—	Unimplemented							
79Dh	—	—	—	Unimplemented							
79Eh	—	—	—	Unimplemented							
79Fh	—	—	—	Unimplemented							

Legend: x = unknown, u = unchanged, c = depends on condition, - = unimplemented, read as '0', r = reserved. Shaded locations unimplemented, read as '0'.

Note 1: Register present on PIC16F18855/75 devices only.

Note 2: Unimplemented, read as '1'.

TABLE 3-13: SPECIAL FUNCTION REGISTER SUMMARY BANKS 0-31 (CONTINUED)

Address	Name	PIC16(L)/F18856	PIC16(L)/F18876	Bit 7	Bit 6	Bit 5	Bit 4	Bit 3	Bit 2	Bit 1	Bit 0
Banks 16											
CPU CORE REGISTERS; see Table 3-2 for specifics											
80Ch	WDTCN0			—	—	PS<4:0>				SEN	
80Dh	WDTCN1			—	WDTCS<2:0>			—	WINDOW<2:0>		
80Eh	WDTPSL			PSCNT<7:0>							
80Fh	WDTPSH			PSCNT<7:0>							
810h	WDTTMR			—	WDTTMR<3:0>				STATE	PSCNT<17:16>	
811h	BORCON			SBOREN	—	—	—	—	—	—	BORRDY
812h	VREGCON ⁽¹⁾			—	—	—	—	—	—	VREGPM	Reserved
813h	PCON0			STKOVF	STKUNF	WDTWV	RWDT	RMCLR	RI	POR	BOR
814h	CCDCON			CCDEN	—	—	—	—	—	CCDS<1:0>	
815h	—	—	—	Unimplemented							
816h	—	—	—	Unimplemented							
817h	—	—	—	Unimplemented							
818h	—	—	—	Unimplemented							
819h	—	—	—	Unimplemented							
81Ah	NVMADRL			NVMADR<7:0>							
81Bh	NVMADRH			— ⁽²⁾	NVMADR<14:8>						
81Ch	NVMDATL			NVMDAT<7:0>							
81Dh	NVMDATH			—	—	NVMDAT<13:8>					
81Eh	NVMCON1			—	NVMREGS	LWLO	FREE	WRERR	WREN	WR	RD
81Fh	NVMCON2			NVMCON2<7:0>							

Legend: x = unknown, u = unchanged, c = depends on condition, - = unimplemented, read as '0', r = reserved. Shaded locations unimplemented, read as '0'.

Note 1: Register present on PIC16F18855/75 devices only.

Note 2: Unimplemented, read as '1'.

TABLE 3-13: SPECIAL FUNCTION REGISTER SUMMARY BANKS 0-31 (CONTINUED)

Address	Name	PIC16(L)/F18856	PIC16(L)/F18876	Bit 7	Bit 6	Bit 5	Bit 4	Bit 3	Bit 2	Bit 1	Bit 0
Banks 17											
CPU CORE REGISTERS; see Table 3-2 for specifics											
88Ch	CPUDOZE			IDLEN	DOZEN	ROI	DOE	—	DOZE2	DOZE1	DOZE0
88Dh	OSCCON1			—	NOSC<2:0>			NDIV<3:0>			
88Eh	OSCCON2			—	COSC<2:0>			CDIV<3:0>			
88Fh	OSCCON3			CSWHOLD	SOSCPWR	—	ORDY	NOSCR	—	—	—
890h	OSCSTAT			EXTOR	HFOR	MFOR	LFOR	SOR	ADOR	—	PLLR
891h	OSCCEN			EXTOEN	HFOEN	MFOEN	LFOEN	SOSCEN	ADOEN	—	—
892h	OSCTUNE			—	—	HFTUN<5:0>					
893h	OSCFRQ			—	—	—	—	—	HFFRQ<2:0>		
894h	—	—	—	Unimplemented							
895h	CLKRCON			CLKREN	—	—	CLKRDC<1:0>		CLKRDIV<2:0>		
896h	CLKRCLK			—	—	—	—	CLKRCLK<3:0>			
897h	MDCON0			MDEN	—	MDOUT	MDOPOL	—	—	—	MDBIT
898h	MDCON1			—	—	MDCHPOL	MDCHSYNC	—	—	MDCLPOL	MDCLSYNC
899h	MDSRC			—	—	—	MDMS<4:0>				
89Ah	MDCARL			—	—	—	—	MDCLS<3:0>			
89Bh	MDCARH			—	—	—	—	MDCHS<3:0>			
89Ch	—	—	—	Unimplemented							
89Dh	—	—	—	Unimplemented							
89Eh	—	—	—	Unimplemented							
89Fh	—	—	—	Unimplemented							

Legend: x = unknown, u = unchanged, q = depends on condition, - = unimplemented, read as '0', r = reserved. Shaded locations unimplemented, read as '0'.

Note 1: Register present on PIC16F18855/75 devices only.

Note 2: Unimplemented, read as '1'.

TABLE 3-13: SPECIAL FUNCTION REGISTER SUMMARY BANKS 0-31 (CONTINUED)

Address	Name	PIC16(L)/F18856	PIC16(L)/F18876	Bit 7	Bit 6	Bit 5	Bit 4	Bit 3	Bit 2	Bit 1	Bit 0
Bank 18											
CPU CORE REGISTERS; see Table 3-2 for specifics											
90Ch	FVRCON			FVREN	FVRRDY	TSEN	TSRNG	CDAFVR<1:0>	ADFVR<1:0>		
90Dh	—	—		Unimplemented							
90Eh	DAC1CON0			DAC1EN	—	DAC1OE1	DAC1OE2	DAC1PSS<1:0>		—	DAC1NSS
90Fh	DAC1CON1			—	—	—	DAC1R<4:0>				
910h	—	—		Unimplemented							
911h	—	—		Unimplemented							
912h	—	—		Unimplemented							
913h	—	—		Unimplemented							
914h	—	—		Unimplemented							
915h	—	—		Unimplemented							
916h	—	—		Unimplemented							
917h	—	—		Unimplemented							
918h	—	—		Unimplemented							
919h	—	—		Unimplemented							
91Ah	—	—		Unimplemented							
91Bh	—	—		Unimplemented							
91Ch	—	—		Unimplemented							
91Dh	—	—		Unimplemented							
91Eh	—	—		Unimplemented							
91Fh	ZCDCON			EN	—	OUT	POL	—	—	INTP	INTN

Legend: x = unknown, u = unchanged, c = depends on condition, - = unimplemented, read as '0', r = reserved. Shaded locations unimplemented, read as '0'.

Note 1: Register present on PIC16F18855/75 devices only.

Note 2: Unimplemented, read as '1'.

TABLE 3-13: SPECIAL FUNCTION REGISTER SUMMARY BANKS 0-31 (CONTINUED)

Address	Name	PIC16(L)/F18856	PIC16(L)/F18876	Bit 7	Bit 6	Bit 5	Bit 4	Bit 3	Bit 2	Bit 1	Bit 0
Bank 19											
CPU CORE REGISTERS; see Table 3-2 for specifics											
98Ch	—	—	—	Unimplemented							
98Dh	—	—	—	Unimplemented							
98Eh	—	—	—	Unimplemented							
98Fh	CMOUT			—	—	—	—	—	—	MC2OUT	MC1OUT
990h	CM1CON0			ON	OUT	—	POL	—	—	HYS	SYNC
991h	CM1CON1			—	—	—	—	—	—	INTP	INTN
992h	CM1NSEL			—	—	—	—	—	NCH<2:0>		
993h	CM1PSEL			—	—	—	—	—	PCH<2:0>		
994h	CM2CON0			ON	OUT	—	POL	—	—	HYS	SYNC
995h	CM2CON1			—	—	—	—	—	—	INTP	INTN
996h	CM2NSEL			—	—	—	—	—	NCH<2:0>		
997h	CM2PSEL			—	—	—	—	—	PCH<2:0>		
998h	—	—	—	Unimplemented							
999h	—	—	—	Unimplemented							
99Ah	—	—	—	Unimplemented							
99Bh	—	—	—	Unimplemented							
99Ch	—	—	—	Unimplemented							
99Dh	—	—	—	Unimplemented							
99Eh	—	—	—	Unimplemented							
99Fh	—	—	—	Unimplemented							

Legend: x = unknown, u = unchanged, c = depends on condition, - = unimplemented, read as '0', r = reserved. Shaded locations unimplemented, read as '0'.

Note 1: Register present on PIC16F18855/75 devices only.

Note 2: Unimplemented, read as '1'.

TABLE 3-13: SPECIAL FUNCTION REGISTER SUMMARY BANKS 0-31 (CONTINUED)

Address	Name	PIC16(L)F18856	PIC16(L)F18876	Bit 7	Bit 6	Bit 5	Bit 4	Bit 3	Bit 2	Bit 1	Bit 0
Bank 20-27											
CPU CORE REGISTERS; see Table 3-2 for specifics											
x0Ch/ x8Ch — x1Fh/ x9Fh	—	—									Unimplemented

Legend: x = unknown, u = unchanged, α = depends on condition, - = unimplemented, read as '0', x = reserved. Shaded locations unimplemented, read as '0'.
Note 1: Register present on PIC16F18855/75 devices only.
2: Unimplemented, read as '1'.

TABLE 3-13: SPECIAL FUNCTION REGISTER SUMMARY BANKS 0-31 (CONTINUED)

Address	Name	PIC16(L)/F18856	PIC16(L)/F18876	Bit 7	Bit 6	Bit 5	Bit 4	Bit 3	Bit 2	Bit 1	Bit 0
Bank 28											
CPU CORE REGISTERS; see Table 3-2 for specifics											
E0Ch	—	—	—	Unimplemented							
E0Dh	—	—	—	Unimplemented							
E0Eh	—	—	—	Unimplemented							
E0Fh	CLCDATA			—	—	—	—	MLC4OUT	MLC3OUT	MLC2OUT	MLC1OUT
E10h	CLC1CON			LC1EN	—	LC1OUT	LC1INTP	LC1INTN	LC1MODE<2:0>		
E11h	CLC1POL			LC1POL	—	—	—	LC1G4POL	LC1G3POL	LC1G2POL	LC1G1POL
E12h	CLC1SEL0			—	—	LC1D1S<5:0>					
E13h	CLC1SEL1			—	—	LC1D2S<5:0>					
E14h	CLC1SEL2			—	—	LC1D3S<5:0>					
E15h	CLC1SEL3			—	—	LC1D4S<5:0>					
E16h	CLC1GLS0			LC1G1D4T	LC1G1D4N	LC1G1D3T	LC1G1D3N	LC1G1D2T	LC1G1D2N	LC1G1D1T	LC1G1D1N
E17h	CLC1GLS1			LC1G2D4T	LC1G2D4N	LC1G2D3T	LC1G2D3N	LC1G2D2T	LC1G2D2N	LC1G2D1T	LC1G2D1N
E18h	CLC1GLS2			LC1G3D4T	LC1G3D4N	LC1G3D3T	LC1G3D3N	LC1G3D2T	LC1G3D2N	LC1G3D1T	LC1G3D1N
E19h	CLC1GLS3			LC1G4D4T	LC1G4D4N	LC1G4D3T	LC1G4D3N	LC1G4D2T	LC1G4D2N	LC1G4D1T	LC1G4D1N
E1Ah	CLC2CON			LC2EN	—	LC2OUT	LC2INTP	LC2INTN	LC2MODE<2:0>		
E1Bh	CLC2POL			LC2POL	—	—	—	LC2G4POL	LC2G3POL	LC2G2POL	LC2G1POL
E1Ch	CLC2SEL0			—	—	LC2D1S<5:0>					
E1Dh	CLC2SEL1			—	—	LC2D2S<5:0>					
E1Eh	CLC2SEL2			—	—	LC2D3S<5:0>					
E1Fh	CLC2SEL3			—	—	LC2D4S<5:0>					
E20h	CLC2GLS0			LC2G1D4T	LC2G1D4N	LC2G1D3T	LC2G1D3N	LC2G1D2T	LC2G1D2N	LC2G1D1T	LC2G1D1N
E21h	CLC2GLS1			LC2G2D4T	LC2G2D4N	LC2G2D3T	LC2G2D3N	LC2G2D2T	LC2G2D2N	LC2G2D1T	LC2G2D1N

Legend: x = unknown, u = unchanged, c = depends on condition, - = unimplemented, read as '0', r = reserved. Shaded locations unimplemented, read as '0'.

Note 1: Register present on PIC16F18855/75 devices only.

2: Unimplemented, read as '1'.

TABLE 3-13: SPECIAL FUNCTION REGISTER SUMMARY BANKS 0-31 (CONTINUED)

Address	Name	PIC16(L)/F18856	PIC16(L)/F18876	Bit 7	Bit 6	Bit 5	Bit 4	Bit 3	Bit 2	Bit 1	Bit 0
Bank 28 (Continued)											
E22h	CLC2GLS2			LC2G3D4T	LC2G3D4N	LC2G3D3T	LC2G3D3N	LC2G3D2T	LC2G3D2N	LC2G3D1T	LC2G3D1N
E23h	CLC2GLS3			LC2G4D4T	LC2G4D4N	LC2G4D3T	LC2G4D3N	LC2G4D2T	LC2G4D2N	LC2G4D1T	LC2G4D1N
E24h	CLC3CON			LC3EN	—	LC3OUT	LC3INTP	LC3INTN	LC3MODE<2:0>		
E25h	CLC3POL			LC3POL	—	—	—	LC3G4POL	LC3G3POL	LC3G2POL	LC3G1POL
E26h	CLC3SEL0			—	—	LC3D1S<5:0>					
E27h	CLC3SEL1			—	—	LC3D2S<5:0>					
E28h	CLC3SEL2			—	—	LC3D3S<5:0>					
E29h	CLC3SEL3			—	—	LC3D4S<5:0>					
E2Ah	CLC3GLS0			LC3G1D4T	LC3G1D4N	LC3G1D3T	LC3G1D3N	LC3G1D2T	LC3G1D2N	LC3G1D1T	LC3G1D1N
E2Bh	CLC3GLS1			LC3G2D4T	LC3G2D4N	LC3G2D3T	LC3G2D3N	LC3G2D2T	LC3G2D2N	LC3G2D1T	LC3G2D1N
E2Ch	CLC3GLS2			LC3G3D4T	LC3G3D4N	LC3G3D3T	LC3G3D3N	LC3G3D2T	LC3G3D2N	LC3G3D1T	LC3G3D1N
E2Dh	CLC3GLS3			LC3G4D4T	LC3G4D4N	LC3G4D3T	LC3G4D3N	LC3G4D2T	LC3G4D2N	LC3G4D1T	LC3G4D1N
E2Eh	CLC4CON			LC4EN	—	LC4OUT	LC4INTP	LC4INTN	LC4MODE<2:0>		
E2Fh	CLC4POL			LC4POL	—	—	—	LC4G4POL	LC4G3POL	LC4G2POL	LC4G1POL
E30h	CLC4SEL0			—	—	LC4D1S<5:0>					
E31h	CLC4SEL1			—	—	LC4D2S<5:0>					
E32h	CLC4SEL2			—	—	LC4D3S<5:0>					
E33h	CLC4SEL3			—	—	LC4D4S<5:0>					
E34h	CLC4GLS0			LC4G1D4T	LC4G1D4N	LC4G1D3T	LC4G1D3N	LC4G1D2T	LC4G1D2N	LC4G1D1T	LC4G1D1N
E35h	CLC4GLS1			LC4G2D4T	LC4G2D4N	LC4G2D3T	LC4G2D3N	LC4G2D2T	LC4G2D2N	LC4G2D1T	LC4G2D1N
E36h	CLC4GLS2			LC4G3D4T	LC4G3D4N	LC4G3D3T	LC4G3D3N	LC4G3D2T	LC4G3D2N	LC4G3D1T	LC4G3D1N
E37h	CLC4GLS3			LC4G4D4T	LC4G4D4N	LC4G4D3T	LC4G4D3N	LC4G4D2T	LC4G4D2N	LC4G4D1T	LC4G4D1N
E38h to E6Fh	—	—	—	Unimplemented							

Legend: x = unknown, u = unchanged, c = depends on condition, - = unimplemented, read as '0', r = reserved. Shaded locations unimplemented, read as '0'.

Note 1: Register present on PIC16F18855/75 devices only.

Note 2: Unimplemented, read as '1'.

TABLE 3-13: SPECIAL FUNCTION REGISTER SUMMARY BANKS 0-31 (CONTINUED)

Address	Name	PIC16(L)/F18856	PIC16(L)/F18876	Bit 7	Bit 6	Bit 5	Bit 4	Bit 3	Bit 2	Bit 1	Bit 0
Bank 29											
CPU CORE REGISTERS; see Table 3-2 for specifics											
E8Ch	—	—	—	Unimplemented							
E8Dh	—	—	—	Unimplemented							
E8Eh	—	—	—	Unimplemented							
E8Fh	PPSLOCK			—	—	—	—	—	—	—	PPSLOCKEN
E90h	INTPPS			—	—	—	—	INTPPS<3:0>			
E91h	T0CKIPPS			—	—	—	—	T0CKIPPS<3:0>			
E92h	T1CKIPPS			—	—	—	T1CKIPPS<4:0>				
E93h	T1GPPS			—	—	—	T1GPPS<4:0>				
E94h	T3CKIPPS			—	—	—	T3CKIPPS<4:0>				
E95h	T3GPPS			—	—	—	T3GPPS<4:0>				
E96h	T5CKIPPS			—	—	—	T5CKIPPS<4:0>				
E97h	T5GPPS			—	—	—	T5GPPS<4:0>				
E98h	—	—	—	Unimplemented							
E99h	—	—	—	Unimplemented							
E9Ah	—	—	—	Unimplemented							
E9Bh	—	—	—	Unimplemented							
E9Ch	T2AINPPS			—	—	—	T2AINPPS<4:0>				
E9Dh	T4AINPPS			—	—	—	T4AINPPS<4:0>				
E9Eh	T6AINPPS			—	—	—	T6AINPPS<4:0>				
E9Fh	—	—	—	Unimplemented							
EA0h	—	—	—	Unimplemented							
EA1h	CCP1PPS			—	—	—	CCP1PPS<4:0>				

Legend: x = unknown, u = unchanged, c = depends on condition, - = unimplemented, read as '0', r = reserved. Shaded locations unimplemented, read as '0'.

Note 1: Register present on PIC16F18855/75 devices only.

2: Unimplemented, read as '1'.

TABLE 3-13: SPECIAL FUNCTION REGISTER SUMMARY BANKS 0-31 (CONTINUED)

Address	Name	PIC16(L)/F18856	PIC16(L)/F18876	Bit 7	Bit 6	Bit 5	Bit 4	Bit 3	Bit 2	Bit 1	Bit 0
Bank 29 (Continued)											
EA2h	CCP2PPS			—	—	—			CCP2PPS<4:0>		
EA3h	CCP3PPS			—	—	—			CCP3PPS<4:0>		
EA4h	CCP4PPS			—	—	—			CCP4PPS<4:0>		
EA5h	CCP5PPS			—	—				CCP5PPS<5:0>		
EA6h	—	—							Unimplemented		
EA7h	—	—							Unimplemented		
EA8h	—	—							Unimplemented		
EA9h	SMT1WINPPS			—	—	—			SMT1WINPPS<4:0>		
EAAh	SMT1SIGPPS			—	—	—			SMT1SIGPPS<4:0>		
EABh	SMT2WINPPS			—	—	—			SMT2WINPPS<4:0>		
EACh	SMT2SIGPPS			—	—	—			SMT2SIGPPS<4:0>		
EADh	—	—							Unimplemented		
EAEh	—	—							Unimplemented		
EAfh	—	—							Unimplemented		
EB0h	—	—							Unimplemented		
EB1h	CWG1PPS			—	—	—			CWG1PPS<4:0>		
EB2h	CWG2PPS			—	—	—			CWG2PPS<4:0>		
EB3h	CWG3PPS			—	—	—			CWG3PPS<4:0>		
EB4h	—	—							Unimplemented		
EB5h	—	—							Unimplemented		
EB6h	—	—							Unimplemented		
EB7h	—	—							Unimplemented		
EB8h	MDCARLPPS			—	—	—			MDCARLPPS<4:0>		
EB9h	MDCARHPPS			—	—	—			MDCARHPPS<4:0>		

Legend: x = unknown, u = unchanged, q = depends on condition, - = unimplemented, read as '0', r = reserved. Shaded locations unimplemented, read as '0'.

Note 1: Register present on PIC16F18855/75 devices only.

2: Unimplemented, read as '1'.

TABLE 3-13: SPECIAL FUNCTION REGISTER SUMMARY BANKS 0-31 (CONTINUED)

Address	Name	PIC16(L)F18856	PIC16(L)F18876	Bit 7	Bit 6	Bit 5	Bit 4	Bit 3	Bit 2	Bit 1	Bit 0
Bank 29 (Continued)											
EBAh	MDSRCPPS			—	—	—					MDSRCPPS<4:0>
EBBh	CLCIN0PPS			—	—	—					CLCIN0PPS<4:0>
EBCh	CLCIN1PPS			—	—	—					CLCIN1PPS<4:0>
EBDh	CLCIN2PPS			—	—	—					CLCIN2PPS<4:0>
EBEh	CLCIN3PPS			—	—	—					CLCIN3PPS<4:0>
EBFh	—	—									Unimplemented
EC0h	—	—									Unimplemented
EC1h	—	—									Unimplemented
EC2h	—	—									Unimplemented
EC3h	ADCACTPPS			—	—	—					ADCACTPPS<4:0>
EC4h	—	—									Unimplemented
EC5h	SSP1CLKPPS			—	—	—					SSP1CLKPPS<4:0>
EC6h	SSP1DATPPS			—	—	—					SSP1DATPPS<4:0>
EC7h	SSP1SSPPS			—	—	—					SSP1SSPPS<4:0>
EC8h	SSP2CLKPPS			—	—	—					SSP2CLKPPS<4:0>
EC9h	SSP2DATPPS			—	—	—					SSP2DATPPS<4:0>
ECAh	SSP2SSPPS			—	—	—					SSP2SSPPS<4:0>
ECBh	RXPPS			—	—	—					RXPPS<4:0>
ECCh	TXPPS			—	—	—					TXPPS<4:0>
ECDh to EEFh	—	—									Unimplemented

Legend: x = unknown, u = unchanged, c = depends on condition, - = unimplemented, read as '0', r = reserved. Shaded locations unimplemented, read as '0'.

Note 1: Register present on PIC16F18855/75 devices only.

Note 2: Unimplemented, read as '1'.

TABLE 3-13: SPECIAL FUNCTION REGISTER SUMMARY BANKS 0-31 (CONTINUED)

Address	Name	PIC16(L)/F18856	PIC16(L)/F18876	Bit 7	Bit 6	Bit 5	Bit 4	Bit 3	Bit 2	Bit 1	Bit 0
Bank 30											
CPU CORE REGISTERS; see Table 3-2 for specifics											
F0Ch — F0Fh	—	—									Unimplemented
F10h	RA0PPS			—	—						RA0PPS<5:0>
F11h	RA1PPS			—	—						RA1PPS<5:0>
F12h	RA2PPS			—	—						RA2PPS<5:0>
F13h	RA3PPS			—	—						RA3PPS<5:0>
F14h	RA4PPS			—	—						RA4PPS<5:0>
F15h	RA5PPS			—	—						RA5PPS<5:0>
F16h	RA6PPS			—	—						RA6PPS<5:0>
F17h	RA7PPS			—	—						RA7PPS<5:0>
F18h	RB0PPS			—	—						RB0PPS<5:0>
F19h	RB1PPS			—	—						RB1PPS<5:0>
F1Ah	RB2PPS			—	—						RB2PPS<5:0>
F1Bh	RB3PPS			—	—						RB3PPS<5:0>
F1Ch	RB4PPS			—	—						RB4PPS<5:0>
F1Dh	RB5PPS			—	—						RB5PPS<5:0>
F1Eh	RB6PPS			—	—						RB6PPS<5:0>
F1Fh	RB7PPS			—	—						RB7PPS<5:0>
F20h	RC0PPS			—	—						RC0PPS<5:0>
F21h	RC1PPS			—	—						RC1PPS<5:0>
F22h	RC2PPS			—	—						RC2PPS<5:0>
F23h	RC3PPS			—	—						RC3PPS<5:0>

Legend: x = unknown, u = unchanged, c = depends on condition, - = unimplemented, read as '0', r = reserved. Shaded locations unimplemented, read as '0'.

Note 1: Register present on PIC16F18855/75 devices only.

2: Unimplemented, read as '1'.

TABLE 3-13: SPECIAL FUNCTION REGISTER SUMMARY BANKS 0-31 (CONTINUED)

Address	Name	PIC16(L)F18856	PIC16(L)F18876	Bit 7	Bit 6	Bit 5	Bit 4	Bit 3	Bit 2	Bit 1	Bit 0
Bank 30 (Continued)											
F24h	RC4PPS			—	—						RC4PPS<5:0>
F25h	RC5PPS			—	—						RC5PPS<5:0>
F26h	RC6PPS			—	—						RC6PPS<5:0>
F27h	RC7PPS			—	—						RC7PPS<5:0>
F28h	RD0PPS	—	X	—	—						RD0PPS<5:0>
		X	—	Unimplemented							
F29h	RD1PPS	—	X	—	—						RD1PPS<5:0>
		X	—	Unimplemented							
F2Ah	RD2PPS	—	X	—	—						RD2PPS<5:0>
		X	—	Unimplemented							
F2Bh	RD3PPS	—	X	—	—						RD3PPS<5:0>
		X	—	Unimplemented							
F2Ch	RD4PPS	—	X	—	—						RD4PPS<5:0>
		X	—	Unimplemented							
F2Dh	RD5PPS	—	X	—	—						RD5PPS<5:0>
		X	—	Unimplemented							
F2Eh	RD6PPS	—	X	—	—						RD6PPS<5:0>
		X	—	Unimplemented							
F2Fh	RD7PPS	—	X	—	—						RD7PPS<5:0>
		X	—	Unimplemented							
F30h	RE0PPS	—	X	—	—						RE0PPS<5:0>
		X	—	Unimplemented							

Legend: x = unknown, u = unchanged, c = depends on condition, - = unimplemented, read as '0', r = reserved. Shaded locations unimplemented, read as '0'.

Note 1: Register present on PIC16F18855/75 devices only.

Note 2: Unimplemented, read as '1'.

TABLE 3-13: SPECIAL FUNCTION REGISTER SUMMARY BANKS 0-31 (CONTINUED)

Address	Name	PIC16(L)/F18856	PIC16(L)/F18876	Bit 7	Bit 6	Bit 5	Bit 4	Bit 3	Bit 2	Bit 1	Bit 0
Bank 30 (Continued)											
F31h	RE1PPS	—	X	—	—	RE1PPS<5:0>					
		X	—	Unimplemented							
F32h	RE2PPS	—	X	—	—	RE2PPS<5:0>					
		X	—	Unimplemented							
F33h — F37h	—	—	—	Unimplemented							
F38h	ANSELA			ANSA7	ANSA6	ANSA5	ANSA4	ANSA3	ANSA2	ANSA1	ANSA0
F39h	WPUA			WPUA7	WPUA6	WPUA5	WPUA4	WPUA3	WPUA2	WPUA1	WPUA0
F3Ah	ODCONA			ODCA7	ODCA6	ODCA5	ODCA4	ODCA3	ODCA2	ODCA1	ODCA0
F3Bh	SLRCONA			SLRA7	SLRA6	SLRA5	SLRA4	SLRA3	SLRA2	SLRA1	SLRA0
F3Ch	INLVLA			INLVLA7	INLVLA6	INLVLA5	INLVLA4	INLVLA3	INLVLA2	INLVLA1	INLVLA0
F3Dh	IOCAP			IOCAP7	IOCAP6	IOCAP5	IOCAP4	IOCAP3	IOCAP2	IOCAP1	IOCAP0
F3Eh	IOCAN			IOCAN7	IOCAN6	IOCAN5	IOCAN4	IOCAN3	IOCAN2	IOCAN1	IOCAN0
F3Fh	IOCAF			IOCAF7	IOCAF6	IOCAF5	IOCAF4	IOCAF3	IOCAF2	IOCAF1	IOCAF0
F40h	CCDNA			CCDNA7	CCDNA6	CCDNA5	CCDNA4	CCDNA3	CCDNA2	CCDNA1	CCDNA0
F41h	CCDPA			CCDPA7	CCDPA6	CCDPA5	CCDPA4	CCDPA3	CCDPA2	CCDPA1	CCDPA0
F42h	—	—	—	Unimplemented							
F43h	ANSELB			ANSB7	ANSB6	ANSB5	ANSB4	ANSB3	ANSB2	ANSB1	ANSB0
F44h	WPUB			WPUB7	WPUB6	WPUB5	WPUB4	WPUB3	WPUB2	WPUB1	WPUB0
F45h	ODCONB			ODCB7	ODCB6	ODCB5	ODCB4	ODCB3	ODCB2	ODCB1	ODCB0
F46h	SLRCONB			SLRB7	SLRB6	SLRB5	SLRB4	SLRB3	SLRB2	SLRB1	SLRB0

Legend: x = unknown, u = unchanged, c = depends on condition, - = unimplemented, read as '0', r = reserved. Shaded locations unimplemented, read as '0'.
Note 1: Register present on PIC16F18855/75 devices only.
Note 2: Unimplemented, read as '1'.

TABLE 3-13: SPECIAL FUNCTION REGISTER SUMMARY BANKS 0-31 (CONTINUED)

Address	Name	PIC16(L)/F18856		Bit 7	Bit 6	Bit 5	Bit 4	Bit 3	Bit 2	Bit 1	Bit 0
Bank 30 (Continued)											
F47h	INLVLB			INLVLB7	INLVLB6	INLVLB5	INLVLB4	INLVLB3	INLVLB2	INLVLB1	INLVLB0
F48h	IOCBP			IOCBP7	IOCBP6	IOCBP5	IOCBP4	IOCBP3	IOCBP2	IOCBP1	IOCBP0
F49h	IOCBN			IOCBN7	IOCBN6	IOCBN5	IOCBN4	IOCBN3	IOCBN2	IOCBN1	IOCBN0
F4Ah	IOCBF			IOCBF7	IOCBF6	IOCBF5	IOCBF4	IOCBF3	IOCBF2	IOCBF1	IOCBF0
F4Bh	CCDNB			CCDNB7	CCDNB6	CCDNB5	CCDNB4	CCDNB3	CCDNB2	CCDNB1	CCDNB0
F4Ch	CCDPB			CCDPB7	CCDPB6	CCDPB5	CCDPB4	CCDPB3	CCDPB2	CCDPB1	CCDPB0
F4Dh	—	—		Unimplemented							
F4Eh	ANSELC			ANSC7	ANSC6	ANSC5	ANSC4	ANSC3	ANSC2	ANSC1	ANSC0
F4Fh	WPUC			WPUC7	WPUC6	WPUC5	WPUC4	WPUC3	WPUC2	WPUC1	WPUC0
F50h	ODCONC			ODCC7	ODCC6	ODCC5	ODCC4	ODCC3	ODCC2	ODCC1	ODCC0
F51h	SLRCONC			SLRC7	SLRC6	SLRC5	SLRC4	SLRC3	SLRC2	SLRC1	SLRC0
F52h	INLVLC			INLVLC7	INLVLC6	INLVLC5	INLVLC4	INLVLC3	INLVLC2	INLVLC1	INLVLC0
F53h	IOCCP			IOCCP7	IOCCP6	IOCCP5	IOCCP4	IOCCP3	IOCCP2	IOCCP1	IOCCP0
F54h	IOCCN			IOCCN7	IOCCN6	IOCCN5	IOCCN4	IOCCN3	IOCCN2	IOCCN1	IOCCN0
F55h	IOCCF			IOCCF7	IOCCF6	IOCCF5	IOCCF4	IOCCF3	IOCCF2	IOCCF1	IOCCF0
F56h	CCDNC			CCDNC7	CCDNC6	CCDNC5	CCDNC4	CCDNC3	CCDNC2	CCDNC1	CCDNC0
F57h	CCDPC			CCDPC7	CCDPC6	CCDPC5	CCDPC4	CCDPC3	CCDPC2	CCDPC1	CCDPC0
F58h	—	—		Unimplemented							
F59h	ANSELD	—	X	ANS7	ANS6	ANS5	ANS4	ANS3	ANS2	ANS1	ANS0
		X	—	Unimplemented							
F5Ah	WPUD	—	X	WPUD7	WPUD6	WPUD5	WPUD4	WPUD3	WPUD2	WPUD1	WPUD0
		X	—	Unimplemented							
F5Bh	ODCOND	—	X	ODCD7	ODCD6	ODCD5	ODCD4	ODCD3	ODCD2	ODCD1	ODCD0
		X	—	Unimplemented							

Legend: x = unknown, u = unchanged, c = depends on condition, - = unimplemented, read as '0', r = reserved. Shaded locations unimplemented, read as '0'.

Note 1: Register present on PIC16F18855/75 devices only.

2: Unimplemented, read as '1'.

TABLE 3-13: SPECIAL FUNCTION REGISTER SUMMARY BANKS 0-31 (CONTINUED)

Address	Name	PIC16(L)F18856	PIC16(L)F18876	Bit 7	Bit 6	Bit 5	Bit 4	Bit 3	Bit 2	Bit 1	Bit 0
Bank 30 (Continued)											
F5Ch	SLRCOND	—	X	SLRD7	SLRD6	SLRD5	SLRD4	SLRD3	SLRD2	SLRD1	SLRD0
		X	—	Unimplemented							
F5Dh	INLVLD	—	X	INLVLD7	INLVLD6	INLVLD5	INLVLD4	INLVLD3	INLVLD2	INLVLD1	INLVLD0
		X	—	Unimplemented							
F5Eh — F60h	—	—	—	Unimplemented							
F61h	CCDND	—	X	CCDND7	CCDND6	CCDND5	CCDND4	CCDND3	CCDND2	CCDND1	CCDND0
		X	—	Unimplemented							
F62h	CCDPD	—	X	CCDPD7	CCDPD6	CCDPD5	CCDPD4	CCDPD3	CCDPD2	CCDPD1	CCDPD0
		X	—	Unimplemented							
F63h	—	—	—	Unimplemented							
F64h	ANSELE	—	X	—	—	—	—	—	ANSE2	ANSE1	ANSE0
		X	—	Unimplemented							
F65h	WPUE	—	X	—	—	—	—	WPUE3	WPUE2	WPUE1	WPUE0
		X	—	—	—	—	—	WPUE3	—	—	—
F66h	ODCONE	—	X	—	—	—	—	—	ODCE2	ODCE1	ODCE0
		X	—	Unimplemented							
F67h	SLRCONE	—	X	—	—	—	—	—	SLRE2	SLRE1	SLRE0
		X	—	Unimplemented							
F68h	INLVLE	—	X	—	—	—	—	INLVLE3	INLVLE2	INLVLE1	INLVLE0
		X	—	—	—	—	—	INLVLE3	—	—	—
F69h	IOCEP	—	—	—	—	—	—	IOCEP3	—	—	—
F6Ah	IOCEN	—	—	—	—	—	—	IOCEN3	—	—	—

Legend: x = unknown, u = unchanged, c = depends on condition, - = unimplemented, read as '0', r = reserved. Shaded locations unimplemented, read as '0'.

Note 1: Register present on PIC16F18855/75 devices only.

Note 2: Unimplemented, read as '1'.

TABLE 3-13: SPECIAL FUNCTION REGISTER SUMMARY BANKS 0-31 (CONTINUED)

Address	Name	PIC16(L)F18856		Bit 7	Bit 6	Bit 5	Bit 4	Bit 3	Bit 2	Bit 1	Bit 0
Bank 30 (Continued)											
F6Bh	IOCEF			—	—	—	—	IOCEF3	—	—	—
F6Ch	CCDNE	—	X	—	—	—	—	—	CCDNE2	CCDNE1	CCDNE0
		X	—	Unimplemented							
F6Dh	CCDPE	—	X	—	—	—	—	—	CCDPE2	CCDPE1	CCDPE0
		X	—	Unimplemented							
F6Eh	—	—	—	Unimplemented							
F6Fh	—	—	—	Unimplemented							

Legend: x = unknown, u = unchanged, c = depends on condition, - = unimplemented, read as '0', r = reserved. Shaded locations unimplemented, read as '0'.

Note 1: Register present on PIC16F18855/75 devices only.

Note 2: Unimplemented, read as '1'.

TABLE 3-13: SPECIAL FUNCTION REGISTER SUMMARY BANKS 0-31 (CONTINUED)

Address	Name	PIC16(L)/F18856	PIC16(L)/F18876	Bit 7	Bit 6	Bit 5	Bit 4	Bit 3	Bit 2	Bit 1	Bit 0
Bank 31											
CPU CORE REGISTERS; see Table 3-2 for specifics											
F8Ch — FE3h		—		Unimplemented							
FE4h	STATUS_SHAD			—	—	—	—	—	Z_SHAD	DC_SHAD	C_SHAD
FE5h	WREG_SHAD			WREG_SHAD							
FE6h	BSR_SHAD			—	—	—	BSR_SHAD				
FE7h	PCLATH_SHAD			—	PCLATH_SHAD						
FE8h	FSR0L_SHAD			FSR0L_SHAD							
FE9h	FSR0H_SHAD			FSR0H_SHAD							
FEAh	FSR1L_SHAD			FSR1L_SHAD							
FEBh	FSR1H_SHAD			FSR1H_SHAD							
FECCh	—	—		Unimplemented							
FEDh	STKPTR			—	—	—	STKPTR<4:0>				
FEEh	TOSL			TOSL<7:0>							
FEFh	TOSH			—	TOSH<6:0>						

Legend: x = unknown, u = unchanged, c = depends on condition, - = unimplemented, read as '0', r = reserved. Shaded locations unimplemented, read as '0'.

Note 1: Register present on PIC16F18855/75 devices only.

Note 2: Unimplemented, read as '1'.

PIC16(L)F18856/76

3.3 PCL and PCLATH

The Program Counter (PC) is 15 bits wide. The low byte comes from the PCL register, which is a readable and writable register. The high byte (PC<14:8>) is not directly readable or writable and comes from PCLATH. On any Reset, the PC is cleared. Figure 3-3 shows the five situations for the loading of the PC.

FIGURE 3-3: LOADING OF PC IN DIFFERENT SITUATIONS

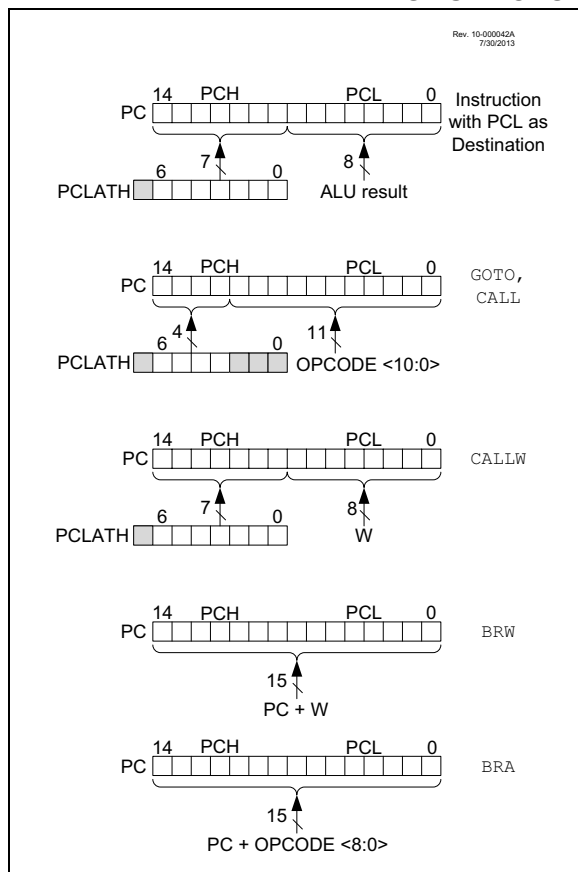

3.3.1 MODIFYING PCL

Executing any instruction with the PCL register as the destination simultaneously causes the Program Counter PC<14:8> bits (PCH) to be replaced by the contents of the PCLATH register. This allows the entire contents of the program counter to be changed by writing the desired upper seven bits to the PCLATH register. When the lower eight bits are written to the PCL register, all 15 bits of the program counter will change to the values contained in the PCLATH register and those being written to the PCL register.

3.3.2 COMPUTED GOTO

A computed GOTO is accomplished by adding an offset to the program counter (ADDWF PCL). When performing a table read using a computed GOTO method, care should be exercised if the table location crosses a PCL memory boundary (each 256-byte block). Refer to Application Note AN556, "Implementing a Table Read" (DS00556).

3.3.3 COMPUTED FUNCTION CALLS

A computed function CALL allows programs to maintain tables of functions and provide another way to execute state machines or look-up tables. When performing a table read using a computed function CALL, care should be exercised if the table location crosses a PCL memory boundary (each 256-byte block).

If using the CALL instruction, the PCH<2:0> and PCL registers are loaded with the operand of the CALL instruction. PCH<6:3> is loaded with PCLATH<6:3>.

The CALLW instruction enables computed calls by combining PCLATH and W to form the destination address. A computed CALLW is accomplished by loading the W register with the desired address and executing CALLW. The PCL register is loaded with the value of W and PCH is loaded with PCLATH.

3.3.4 BRANCHING

The branching instructions add an offset to the PC. This allows relocatable code and code that crosses page boundaries. There are two forms of branching, BRW and BRA. The PC will have incremented to fetch the next instruction in both cases. When using either branching instruction, a PCL memory boundary may be crossed.

If using BRW, load the W register with the desired unsigned address and execute BRW. The entire PC will be loaded with the address PC + 1 + W.

If using BRA, the entire PC will be loaded with PC + 1, the signed value of the operand of the BRA instruction.

PIC16(L)F18856/76

3.4 Stack

All devices have a 16-level x 15-bit wide hardware stack (refer to [Figure 3-4](#) through [Figure 3-7](#)). The stack space is not part of either program or data space. The PC is PUSHed onto the stack when `CALL` or `CALLW` instructions are executed or an interrupt causes a branch. The stack is POPed in the event of a `RETURN`, `RETLW` or a `RETFIE` instruction execution. `PCLATH` is not affected by a `PUSH` or `POP` operation.

The stack operates as a circular buffer if the `STVREN` bit is programmed to '0' (Configuration Words). This means that after the stack has been PUSHed sixteen times, the seventeenth PUSH overwrites the value that was stored from the first PUSH. The eighteenth PUSH overwrites the second PUSH (and so on). The `STKOVF` and `STKUNF` flag bits will be set on an Overflow/Underflow, regardless of whether the Reset is enabled.

Note 1: There are no instructions/mnemonics called `PUSH` or `POP`. These are actions that occur from the execution of the `CALL`, `CALLW`, `RETURN`, `RETLW` and `RETFIE` instructions or the vectoring to an interrupt address.

3.4.1 ACCESSING THE STACK

The stack is available through the `TOSH`, `TOSL` and `STKPTR` registers. `STKPTR` is the current value of the Stack Pointer. `TOSH:TOSL` register pair points to the TOP of the stack. Both registers are read/writable. `TOS` is split into `TOSH` and `TOSL` due to the 15-bit size of the PC. To access the stack, adjust the value of `STKPTR`, which will position `TOSH:TOSL`, then read/write to `TOSH:TOSL`. `STKPTR` is five bits to allow detection of overflow and underflow.

Note: Care should be taken when modifying the `STKPTR` while interrupts are enabled.

During normal program operation, `CALL`, `CALLW` and interrupts will increment `STKPTR` while `RETLW`, `RETURN`, and `RETFIE` will decrement `STKPTR`. At any time, `STKPTR` can be inspected to see how much stack is left. The `STKPTR` always points at the currently used place on the stack. Therefore, a `CALL` or `CALLW` will increment the `STKPTR` and then write the PC, and a return will unload the PC and then decrement the `STKPTR`.

Reference [Figure 3-4](#) through [Figure 3-7](#) for examples of accessing the stack.

FIGURE 3-4: ACCESSING THE STACK EXAMPLE 1

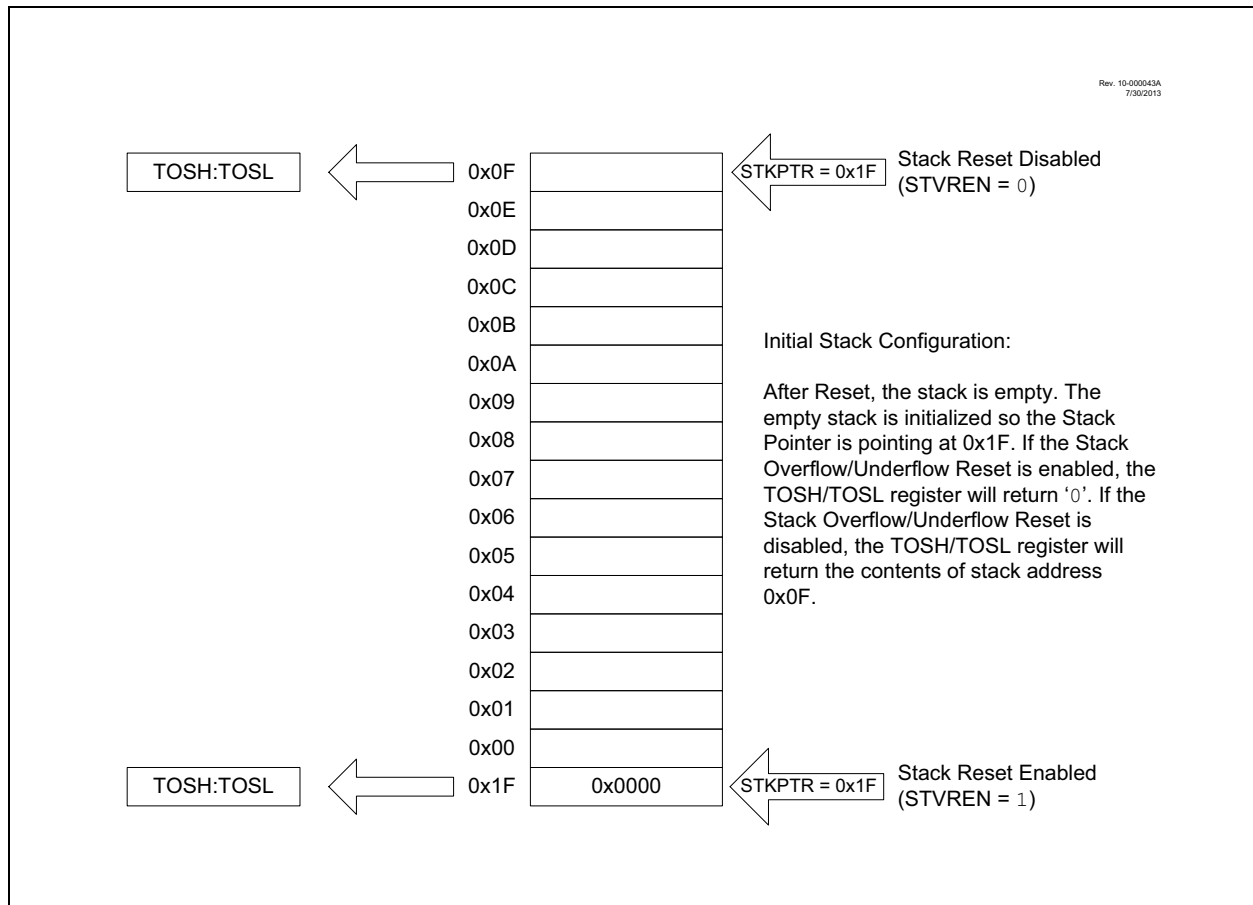

PIC16(L)F18856/76

FIGURE 3-5: ACCESSING THE STACK EXAMPLE 2

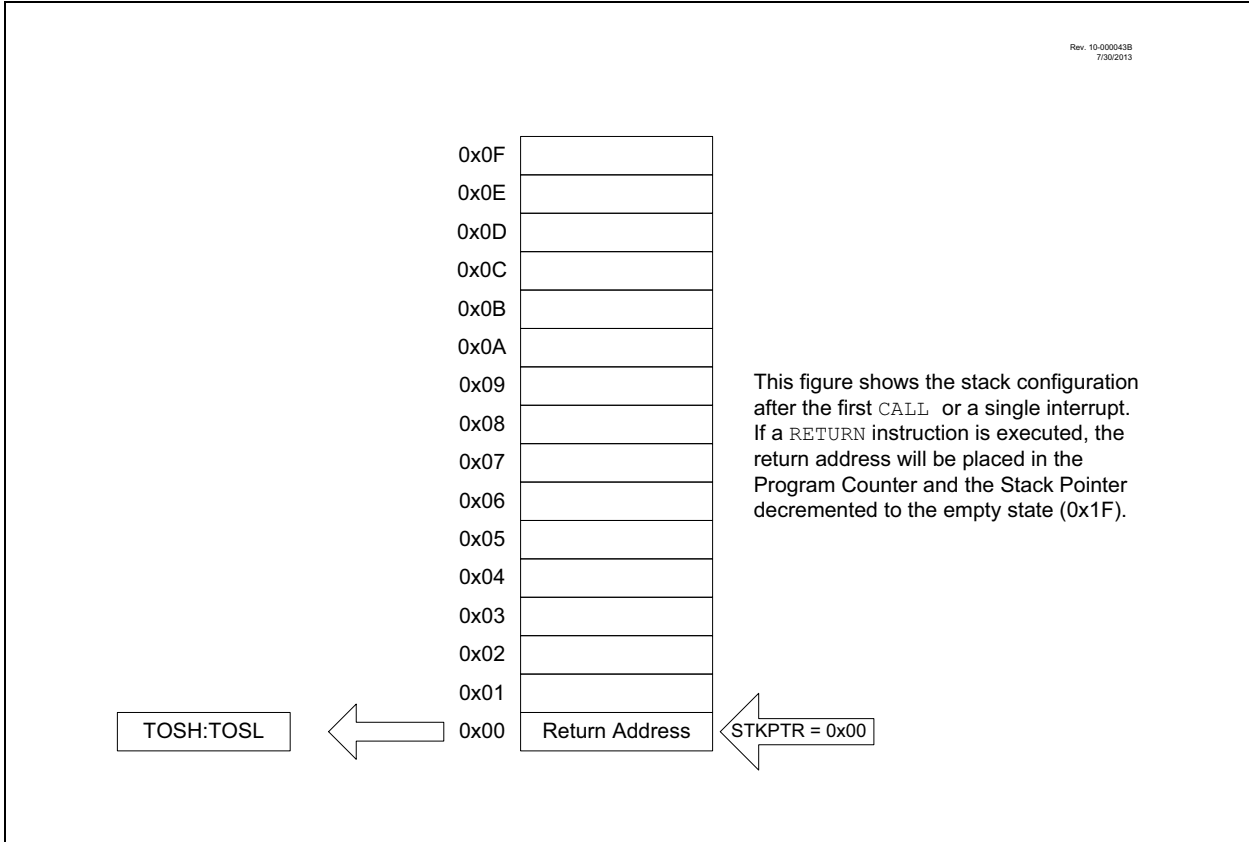
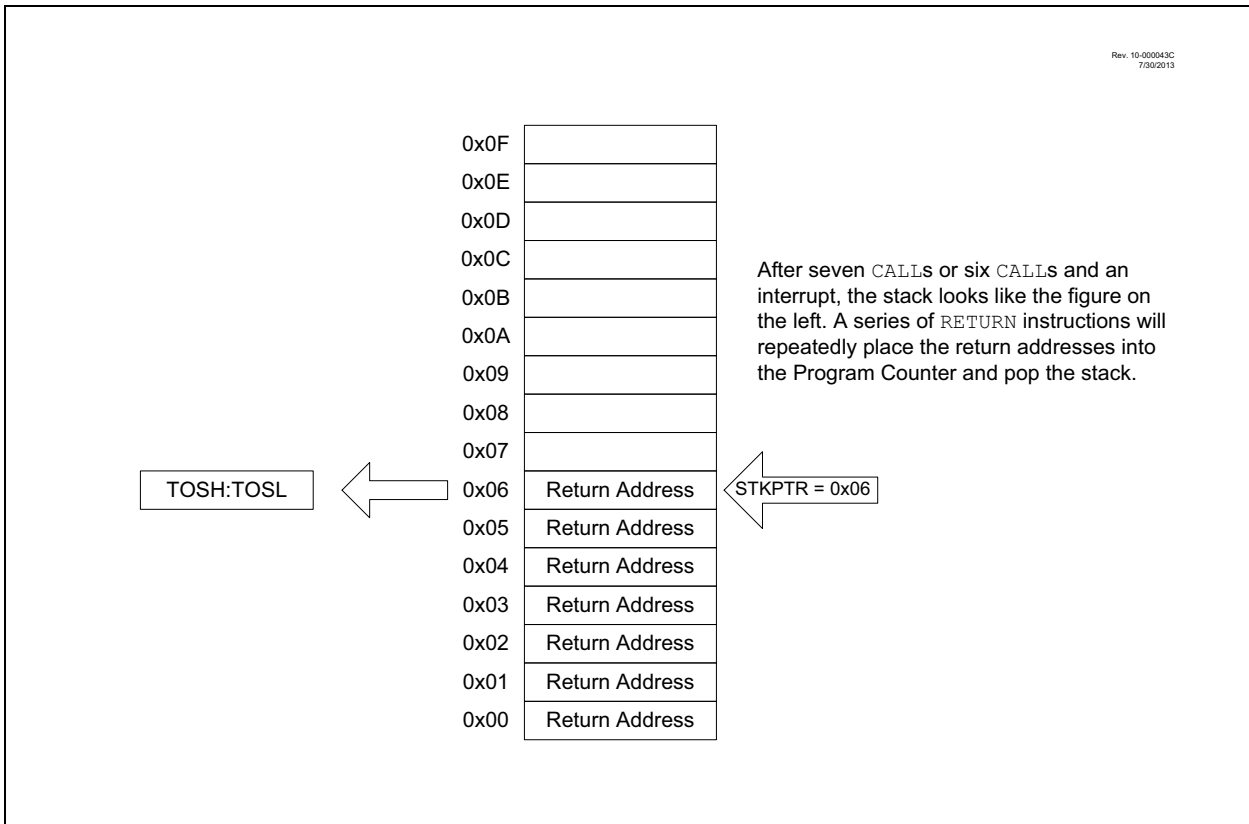
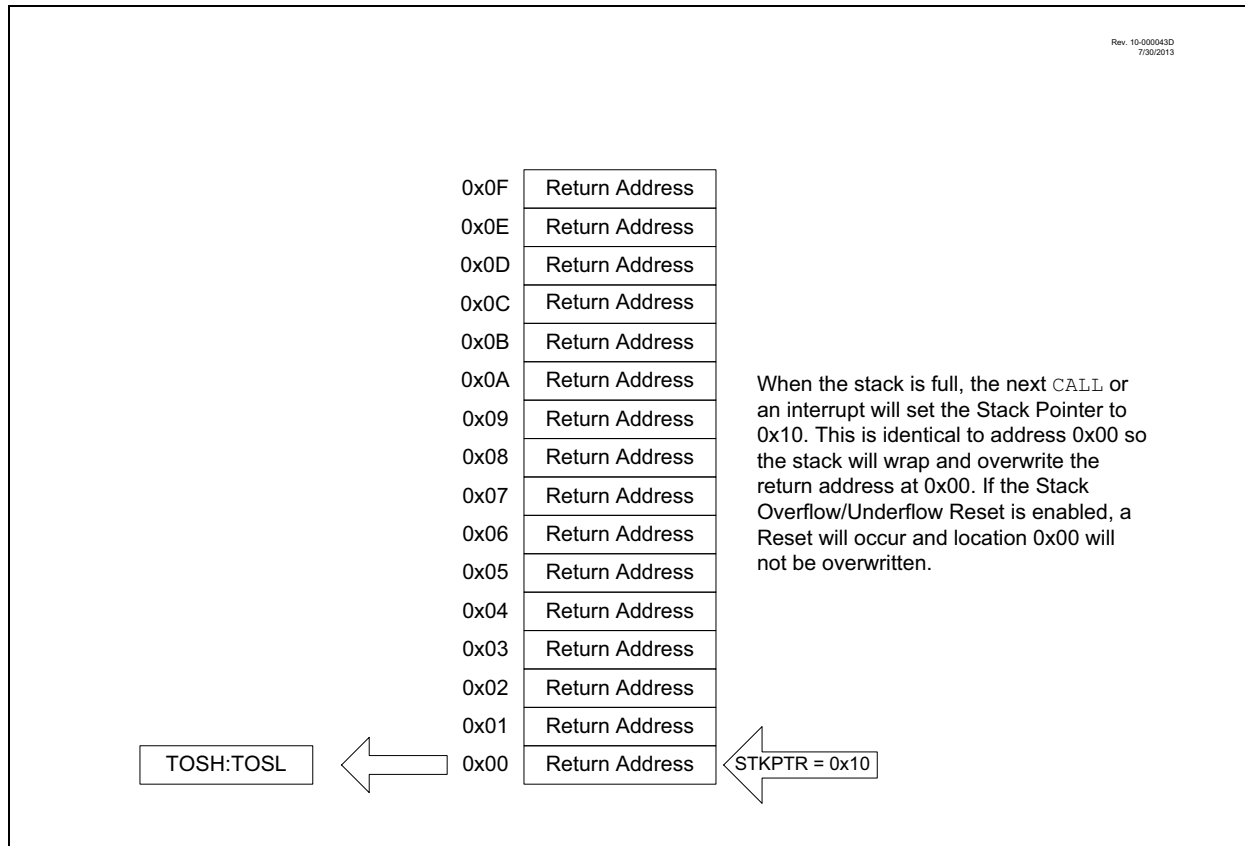

FIGURE 3-6: ACCESSING THE STACK EXAMPLE 3



PIC16(L)F18856/76

FIGURE 3-7: ACCESSING THE STACK EXAMPLE 4



3.4.2 OVERFLOW/UNDERFLOW RESET

If the STVREN bit in Configuration Words is programmed to '1', the device will be Reset if the stack is PUSHed beyond the sixteenth level or POPed beyond the first level, setting the appropriate bits (STKOVF or STKUNF, respectively) in the PCON register.

3.5 Indirect Addressing

The INDFn registers are not physical registers. Any instruction that accesses an INDFn register actually accesses the register at the address specified by the File Select Registers (FSR). If the FSRn address specifies one of the two INDFn registers, the read will return '0' and the write will not occur (though Status bits may be affected). The FSRn register value is created by the pair FSRnH and FSRnL.

The FSR registers form a 16-bit address that allows an addressing space with 65536 locations. These locations are divided into three memory regions:

- Traditional Data Memory
- Linear Data Memory
- Data EEPROM Memory
- Program Flash Memory

PIC16(L)F18856/76

FIGURE 3-8: INDIRECT ADDRESSING

Rev. 10-000044A
7/30/2013

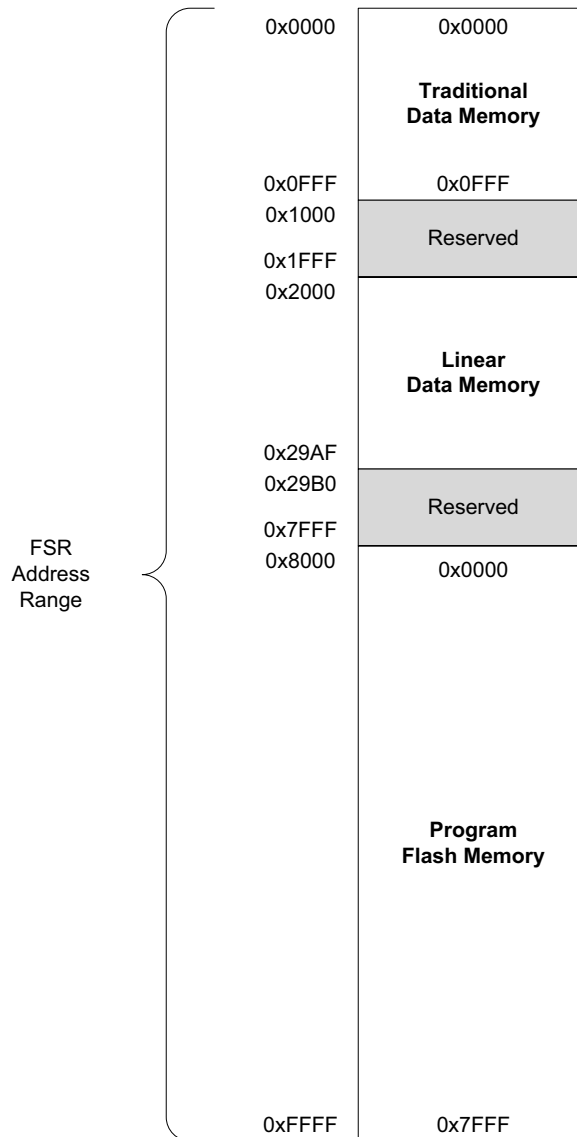

Note: Not all memory regions are completely implemented. Consult device memory tables for memory limits.

PIC16(L)F18856/76

3.5.1 TRADITIONAL DATA MEMORY

The traditional data memory is a region from FSR address 0x000 to FSR address 0xFFF. The addresses correspond to the absolute addresses of all SFR, GPR and common registers.

PIC16(L)F18856/76

FIGURE 3-9: TRADITIONAL DATA MEMORY MAP

Rev. 10-00058A
7/31/2013

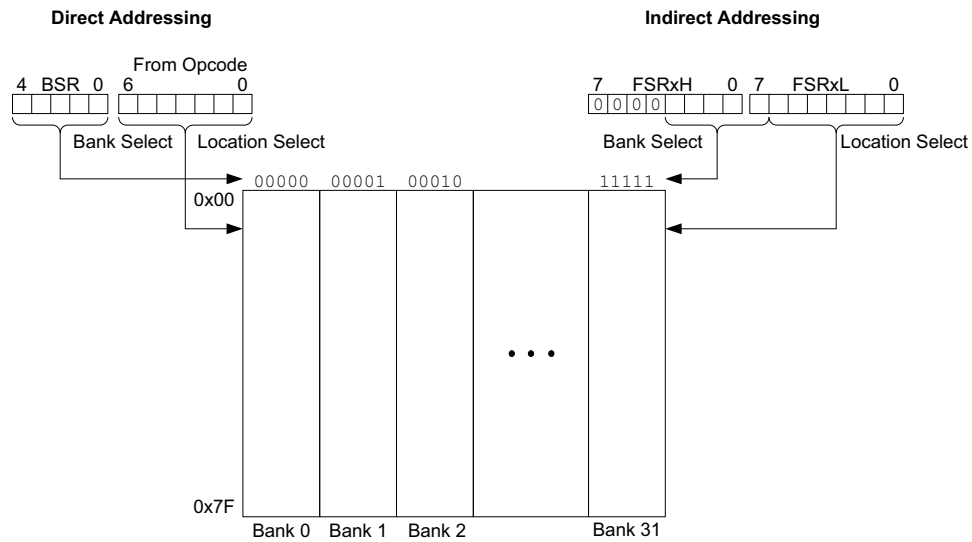

PIC16(L)F18856/76

3.5.2 LINEAR DATA MEMORY

The linear data memory is the region from FSR address 0x2000 to FSR address 0x29AF. This region is a virtual region that points back to the 80-byte blocks of GPR memory in all the banks.

Unimplemented memory reads as 0x00. Use of the linear data memory region allows buffers to be larger than 80 bytes because incrementing the FSR beyond one bank will go directly to the GPR memory of the next bank.

The 16 bytes of common memory are not included in the linear data memory region.

FIGURE 3-10: TRADITIONAL DATA MEMORY MAP

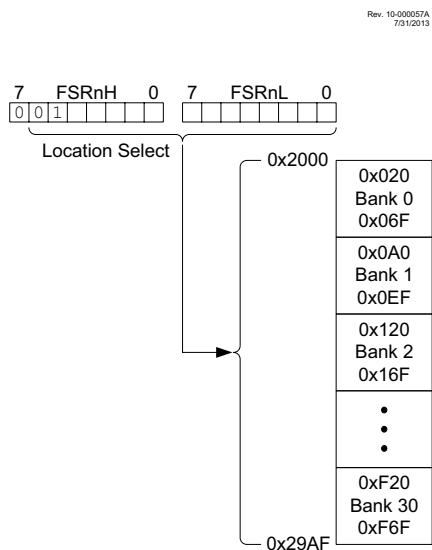

3.5.3 DATA EEPROM MEMORY

The EEPROM memory can be read or written through the NVMCONx/NVMADRx/NVMDATx register interface (see section [Section 10.2 “Data EEPROM Memory”](#)). However, to make access to the EEPROM memory easier, read-only access to the EEPROM contents are also available through indirect addressing by an FSR. When the MSB of the FSR (ex: FSRxH) is set to 0x70, the lower 8-bit address value (in FSRxL) determines the EEPROM location that may be read from (through the INDF register). In other words, the EEPROM address range 0x00-0xFF is mapped into the FSR address space between 0x7000-0x70FF. Writing to the EEPROM cannot be accomplished via the FSR/INDF interface. Reads from the EEPROM through the FSR/INDF interface will require one additional instruction cycle to complete.

3.5.4 PROGRAM FLASH MEMORY

To make constant data access easier, the entire Program Flash Memory is mapped to the upper half of the FSR address space. When the MSB of FSRnH is set, the lower 15 bits are the address in program memory which will be accessed through INDF. Only the lower eight bits of each memory location is accessible via INDF. Writing to the Program Flash Memory cannot be accomplished via the FSR/INDF interface. All instructions that access Program Flash Memory via the FSR/INDF interface will require one additional instruction cycle to complete.

FIGURE 3-11: PROGRAM FLASH MEMORY MAP

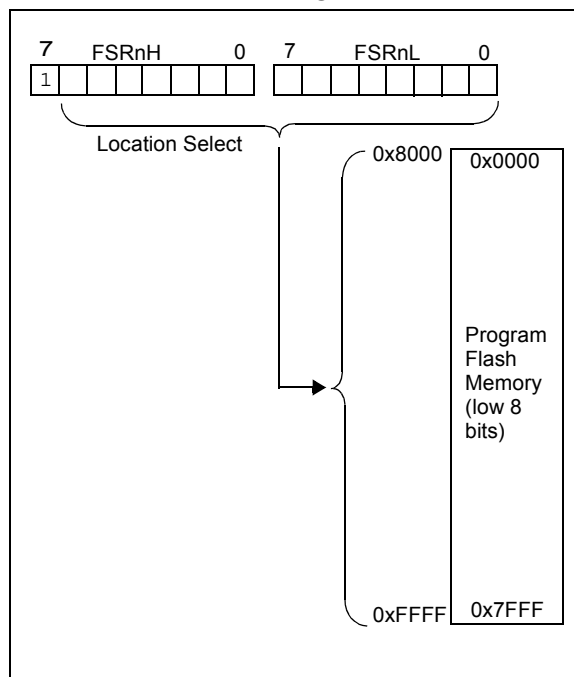

PIC16(L)F18856/76

4.0 DEVICE CONFIGURATION

Device configuration consists of Configuration Words, Code Protection and Device ID.

4.1 Configuration Words

There are several Configuration Word bits that allow different oscillator and memory protection options. These are implemented as shown in [Table 4-1](#).

TABLE 4-1: CONFIGURATION WORD LOCATIONS

Configuration Word	Location
CONFIG1	8007h
CONFIG2	8008h
CONFIG3	8009h
CONFIG4	800Ah
CONFIG5	800Bh

Note: The $\overline{\text{DEBUG}}$ bit in Configuration Words is managed automatically by device development tools including debuggers and programmers. For normal device operation, this bit should be maintained as a '1'.

PIC16(L)F18856/76

4.2 Register Definitions: Configuration Words

REGISTER 4-1: CONFIG1: CONFIGURATION WORD 1: OSCILLATORS

R/P-1	U-1	R/P-1	U-1	U-1	R/P-1
FCMEN	—	CSWEN	—	—	CLKOUTEN
bit 13					bit 8

U-1	R/P-1	R/P-1	R/P-1	U-1	R/P-1	R/P-1	R/P-1
—	RSTOSC<2:0>			—	FEXTOSC<2:0>		
bit 7							bit 0

Legend:

R = Readable bit	P = Programmable bit	U = Unimplemented bit, read as '1'
'0' = Bit is cleared	'1' = Bit is set	n = Value when blank or after Bulk Erase

bit 13 **FCMEN:** Fail-Safe Clock Monitor Enable bit

- 1 = ON FSCM timer enabled
- 0 = OFF FSCM timer disabled

bit 12 **Unimplemented:** Read as '1'

bit 11 **CSWEN:** Clock Switch Enable bit

- 1 = ON Writing to NOSC and NDIV is allowed
- 0 = OFF The NOSC and NDIV bits cannot be changed by user software

bit 10-9 **Unimplemented:** Read as '1'

bit 8 **CLKOUTEN:** Clock Out Enable bit

If FEXTOSC = EC (high, mid or low) or Not Enabled

- 1 = OFF CLKOUT function is disabled; I/O or oscillator function on OSC2
- 0 = ON CLKOUT function is enabled; Fosc/4 clock appears at OSC2

Otherwise

This bit is ignored.

bit 7 **Unimplemented:** Read as '1'

bit 6-4 **RSTOSC<2:0>:** Power-up Default Value for COSC bits

This value is the Reset default value for COSC, and selects the oscillator first used by user software

- 111 = EXT1X EXTOSC operating per FEXTOSC bits
- 110 = HFINT1 HFINTOSC (1 MHz)
- 101 = LFINT LFINTOSC
- 100 = SOSC SOSC
- 011 = Reserved
- 010 = EXT4X EXTOSC with 4x PLL, with EXTOSC operating per FEXTOSC bits
- 001 = HFINTPLL HFINTOSC with 2x PLL, with OSCFRQ = 16 MHz and CDIV = 1:1 (Fosc = 32 MHz)
- 000 = HFINT32 HFINTOSC with OSCFRQ = 32 MHz and CDIV = 1:1

bit 3 **Unimplemented:** Read as '1'

bit 2-0 **FEXTOSC<2:0>:** FEXTOSC External Oscillator mode Selection bits

- 111 = ECH EC (External Clock)
- 110 = ECM EC (External Clock)
- 101 = ECL EC (External Clock)
- 100 = OFF External Oscillator is disabled. RA7 is available as a general purpose I/O.
- 011 = Reserved
- 010 = HS HS (Crystal oscillator)
- 001 = XT XT (Crystal oscillator)
- 000 = LP LP (Crystal oscillator)

PIC16(L)F18856/76

REGISTER 4-2: CONFIG2: CONFIGURATION WORD 2: SUPERVISORS

R/P-1	R/P-1	R/P-1	R/P-1	R/P-1	U-1
$\overline{\text{DEBUG}}$	STVREN	PPS1WAY	ZCDDIS	BORV	—
bit 13					bit 8

R/P-1	R/P-1	R/P-1	U-1	U-1	U-1	R/P-1	R/P-1
BOREN<1:0>	$\overline{\text{LPBOREN}}$	—	—	—	$\overline{\text{PWRT}}\overline{\text{E}}$	MCLRE	
bit 7							bit 0

Legend:

R = Readable bit

P = Programmable bit

U = Unimplemented bit, read as '1'

'0' = Bit is cleared

'1' = Bit is set

n = Value when blank or after Bulk Erase

- bit 13 **DEBUG:** Debugger Enable bit⁽²⁾
 1 = OFF Background debugger disabled; ICSPCLK and ICSPDAT are general purpose I/O pins
 0 = ON Background debugger enabled; ICSPCLK and ICSPDAT are dedicated to the debugger
- bit 12 **STVREN:** Stack Overflow/Underflow Reset Enable bit
 1 = ON Stack Overflow or Underflow will cause a Reset
 0 = OFF Stack Overflow or Underflow will not cause a Reset
- bit 11 **PPS1WAY:** PPSLOCKED One-Way Set Enable bit
 1 = ON The PPSLOCKED bit can be cleared and set only once; PPS registers remain locked after one clear/set cycle
 0 = OFF The PPSLOCKED bit can be set and cleared repeatedly (subject to the unlock sequence)
- bit 10 **ZCDDIS:** Zero-Cross Detect Disable bit
 1 = ON ZCD disabled. ZCD can be enabled by setting the EN bit of the ZCDxCON register
 0 = OFF ZCD always enabled (EN bit is ignored)
- bit 9 **BORV:** Brown-out Reset Voltage Selection bit⁽¹⁾
 1 = LOW Brown-out Reset voltage (**VBOR**) set to lower trip point level
 0 = HIGH Brown-out Reset voltage (**VBOR**) set to higher trip point level
 The higher voltage setting is recommended for operation at or above 16 MHz.
- bit 8 **Unimplemented:** Read as '1'
- bit 7-6 **BOREN<1:0>:** Brown-out Reset Enable bits
 When enabled, Brown-out Reset Voltage (**VBOR**) is set by the BORV bit
 11 = ON Brown-out Reset is enabled; SBOREN bit is ignored
 10 = SLEEP Brown-out Reset is enabled while running, disabled in Sleep; SBOREN bit is ignored
 01 = SBOREN Brown-out Reset is enabled according to SBOREN
 00 = OFF Brown-out Reset is disabled
- bit 5 **LPBOREN:** Low-power BOR enable bit
 1 = LPBOR disabled
 0 = LPBOR enabled
- bit 4-2 **Unimplemented:** Read as '1'
- bit 1 **PWRT:** Power-up Timer Enable bit
 1 = OFF PWRT is disabled
 0 = ON PWRT is enabled
- bit 0 **MCLRE:** Master Clear ($\overline{\text{MCLR}}$) Enable bit
 If LVP = 1:
 RA3 pin function is $\overline{\text{MCLR}}$.
 If LVP = 0:
 1 = ON $\overline{\text{MCLR}}$ pin is $\overline{\text{MCLR}}$.
 0 = OFF $\overline{\text{MCLR}}$ pin function is port-defined function.

- Note** 1: See **VBOR** parameter for specific trip point voltages.
 2: The **DEBUG** bit in Configuration Words is managed automatically by device development tools including debuggers and programmers. For normal device operation, this bit should be maintained as a '1'.

PIC16(L)F18856/76

REGISTER 4-3: CONFIG3: CONFIGURATION WORD 3: WINDOWED WATCHDOG

R/P-1	R/P-1	R/P-1	R/P-1	R/P-1	R/P-1
WDTCCS<2:0>			WDTCWS<2:0>		
bit 13			bit 8		

U-1	R/P-1	R/P-1	R/P-1	R/P-1	R/P-1	R/P-1	R/P-1
	WDTE<1:0>		WDTCPS<4:0>				
bit 7		bit 0					

Legend:

R = Readable bit	P = Programmable bit	x = Bit is unknown	U = Unimplemented bit, read as '1'
'0' = Bit is cleared	'1' = Bit is set	W = Writable bit	n = Value when blank or after Bulk Erase

bit 13-11 **WDTCCS<2:0>**: WDT Input Clock Selector bits

- 111 = Software Control
- 110 = Reserved
- .
- .
- 010 = Reserved
- 001 = WDT reference clock is the MFINTOSC/16 output (31.25 kHz)
- 000 = WDT reference clock is the 31.0 kHz LFINTOSC (default value)

bit 10-8 **WDTCWS<2:0>**: WDT Window Select bits

WDTCWS	WDTWS at POR			Software control of WDTWS?	Keyed access required?
	Value	Window delay Percent of time	Window opening Percent of time		
111	111	n/a	100	Yes	No
110	111	n/a	100	No	Yes
101	101	25	75		
100	100	37.5	62.5		
011	011	50	50		
010	010	62.5	37.5		
001	001	75	25		
000	000	87.5	12.5		

bit 7 **Unimplemented**: Read as '1'

bit 6-5 **WDTE<1:0>**: WDT Operating mode:

- 11 = WDT enabled regardless of Sleep; SWDTEN is ignored
- 10 = WDT enabled while Sleep = 0, suspended when Sleep = 1; SWDTEN ignored
- 01 = WDT enabled/disabled by SWDTEN bit in WDTCON0
- 00 = WDT disabled, SWDTEN is ignored

PIC16(L)F18856/76

REGISTER 4-3: CONFIG3: CONFIGURATION WORD 3: WINDOWED WATCHDOG (CONTINUED)

bit 4-0 WDTCP3<4:0>: WDT Period Select bits

WDTCP3	WDTPS at POR				Software control of WDTPS?
	Value	Divider Ratio		Typical time out (F _{IN} = 31 kHz)	
11110 ... 10011	11110 ... 10011	1:32	2 ⁵	1 ms	No
10010	10010	1:8388608	2 ²³	256 s	No
10001	10001	1:4194304	2 ²²	128 s	
10000	10000	1:2097152	2 ²¹	64 s	
01111	01111	1:1048576	2 ²⁰	32 s	
01110	01110	1:524299	2 ¹⁹	16 s	
01101	01101	1:262144	2 ¹⁸	8 s	
01100	01100	1:131072	2 ¹⁷	4 s	
01011	01011	1:65536	2 ¹⁶	2 s	
01010	01010	1:32768	2 ¹⁵	1 s	
01001	01001	1:16384	2 ¹⁴	512 ms	
01000	01000	1:8192	2 ¹³	256 ms	
00111	00111	1:4096	2 ¹²	128 ms	
00110	00110	1:2048	2 ¹¹	64 ms	
00101	00101	1:1024	2 ¹⁰	32 ms	
00100	00100	1:512	2 ⁹	16 ms	
00011	00011	1:256	2 ⁸	8 ms	
00010	00010	1:128	2 ⁷	4 ms	
00001	00001	1:64	2 ⁶	2 ms	
00000	00000	1:32	2 ⁵	1 ms	

PIC16(L)F18856/76

REGISTER 4-4: CONFIG4: CONFIGURATION WORD 4: MEMORY

R/P-1	R/P-1	U-1	U-1	U-1	U-1	U-1	U-1	U-1	U-1	U-1	U-1	R/P-1	R/P-1
LVP	SCANE	—	—	—	—	—	—	—	—	—	—	WRT<1:0>	
bit 13												bit 0	

Legend:

R = Readable bit	P = Programmable bit	x = Bit is unknown	U = Unimplemented bit, read as '1'
'0' = Bit is cleared	'1' = Bit is set	W = Writable bit	n = Value when blank or after Bulk Erase

- bit 13 **LVP**: Low-Voltage Programming Enable bit
 1 = Low-Voltage Programming is enabled. $\overline{\text{MCLR}}/\text{VPP}$ pin function is $\overline{\text{MCLR}}$. MCLRRE Configuration bit is ignored.
 0 = High voltage (meeting V_{IH} level) on $\overline{\text{MCLR}}/\text{VPP}$ must be used for programming.
 The LVP bit cannot be written (to zero) while operating from the LVP programming interface. This prevents accidental lockout from low-voltage programming while using low-voltage programming. High voltage programming is always available, regardless of the LVP Configuration bit value.
- bit 12 **SCANE**: Scanner Enable bit
 1 = Scanner module is available for use, SCANMD bit enables the module.
 0 = Scanner module is NOT available for use, SCANMD bit is ignored.
- bit 11-2 **Unimplemented**: Read as '1'
- bit 1-0 **WRT<1:0>**: Program Flash Self-Write Erase Protection bits
 11 = Write protection off
 10 = 0000h to 01FFh write-protected, 0200h to 3FFFh may be modified by EECON control
 01 = 0000h to 1FFFh write-protected, 2000h to 3FFFh may be modified by EECON control
 00 = 0000h to 3FFFh write-protected, no addresses may be modified by EECON control

PIC16(L)F18856/76

REGISTER 4-5: CONFIG5: CONFIGURATION WORD 5: CODE PROTECTION

U-1	U-1	U-1	U-1	U-1	U-1
—	—	—	—	—	—
bit 13					bit 8

U-1	U-1	U-1	U-1	U-1	U-1	R/P-1	R/P-1
—	—	—	—	—	—	$\overline{\text{CPD}}$	$\overline{\text{CP}}$
bit 7						bit 0	

Legend:

R = Readable bit	P = Programmable bit	x = Bit is unknown	U = Unimplemented bit, read as '1'
'0' = Bit is cleared	'1' = Bit is set	W = Writable bit	n = Value when blank or after Bulk Erase

bit 13-2 **Unimplemented:** Read as '1'

bit 1 **CPD:** Data NVM (EEPROM) Memory Code Protection bit

1 = EEPROM code protection disabled

0 = EEPROM code protection enabled

bit 0 **CP:** Program Flash Memory Code Protection bit

1 = Program Flash Memory code protection disabled

0 = Program Flash Memory code protection enabled

4.3 Code Protection

Code protection allows the device to be protected from unauthorized access. Program memory protection and data memory are controlled independently. Internal access to the program memory is unaffected by any code protection setting.

4.3.1 PROGRAM MEMORY PROTECTION

The entire program memory space is protected from external reads and writes by the CP bit in Configuration Words. When $\overline{CP} = 0$, external reads and writes of program memory are inhibited and a read will return all '0's. The CPU can continue to read program memory, regardless of the protection bit settings. Self-writing the program memory is dependent upon the write protection setting. See [Section 4.4 "Write Protection"](#) for more information.

4.3.2 DATA MEMORY PROTECTION

The entire data EEPROM memory space is protected from external reads and writes by the CPD bit in the Configuration Words. When $\overline{CPD} = 0$, external reads and writes of EEPROM memory are inhibited and a read will return all '0's. The CPU can continue to read EEPROM memory, regardless of the protection bit settings.

4.4 Write Protection

Write protection allows the device to be protected from unintended self-writes. Applications, such as boot loader software, can be protected while allowing other regions of the program memory to be modified.

The WRT<1:0> bits in Configuration Words define the size of the program memory block that is protected.

4.5 User ID

Four memory locations (8000h-8003h) are designated as ID locations where the user can store checksum or other code identification numbers. These locations are readable and writable during normal execution. See [Section 10.4.7 "NVMREG Data EEPROM Memory, User ID, Device ID and Configuration Word Access"](#) for more information on accessing these memory locations. For more information on checksum calculation, see the *"PIC16(L)F188XX Memory Programming Specification"* (DS40001753).

PIC16(L)F18856/76

4.6 Device ID and Revision ID

The 14-bit device ID word is located at 8006h and the 14-bit revision ID is located at 8005h. These locations are read-only and cannot be erased or modified.

Development tools, such as device programmers and debuggers, may be used to read the Device ID, Revision ID and Configuration Words. These locations can also be read from the NVMCON register.

4.7 Register Definitions: Device and Revision

REGISTER 4-6: DEVID: DEVICE ID REGISTER

R	R	R	R	R	R	R	R
DEV<13:8>							
bit 13				bit 8			

R	R	R	R	R	R	R	R
DEV<7:0>							
bit 7				bit 0			

Legend:

R = Readable bit

'1' = Bit is set

'0' = Bit is cleared

bit 13-0 **DEV<13:0>**: Device ID bits

Device	DEVID<13:0> Values
PIC16F18856	11 0000 0111 0000 (3070h)
PIC16LF18856	11 0000 0111 0010 (3072h)
PIC16F18876	11 0000 0111 0001 (3071h)
PIC16LF18876	11 0000 0111 0011 (3073h)

REGISTER 4-7: REVISIONID: REVISION ID REGISTER

R	R	R	R	R	R	R	R	R	R	R	R	R	R
1	0	MJRREV<5:0>					MNRREV<5:0>						
bit 13				bit 0									

Legend:

R = Readable bit

'0' = Bit is cleared

'1' = Bit is set

x = Bit is unknown

bit 13-12 **Fixed Value**: Read-only bits

These bits are fixed with value '10' for all devices included in this data sheet.

bit 11-6 **MJRREV<5:0>**: Major Revision ID bits

These bits are used to identify a major revision. A major revision is indicated by an all layer revision (B0, C0, etc.)

bit 5-0 **MNRREV<5:0>**: Minor Revision ID bits

These bits are used to identify a minor revision.

PIC16(L)F18856/76

5.0 RESETS

There are multiple ways to reset this device:

- Power-On Reset (POR)
- Brown-Out Reset (BOR)
- MCLR Reset
- WDT Reset
- RESET instruction
- Stack Overflow
- Stack Underflow
- Programming mode exit

To allow VDD to stabilize, an optional Power-up timer can be enabled to extend the Reset time after a BOR or POR event.

A simplified block diagram of the On-Chip Reset Circuit is shown in [Figure 5-1](#).

FIGURE 5-1: SIMPLIFIED BLOCK DIAGRAM OF ON-CHIP RESET CIRCUIT

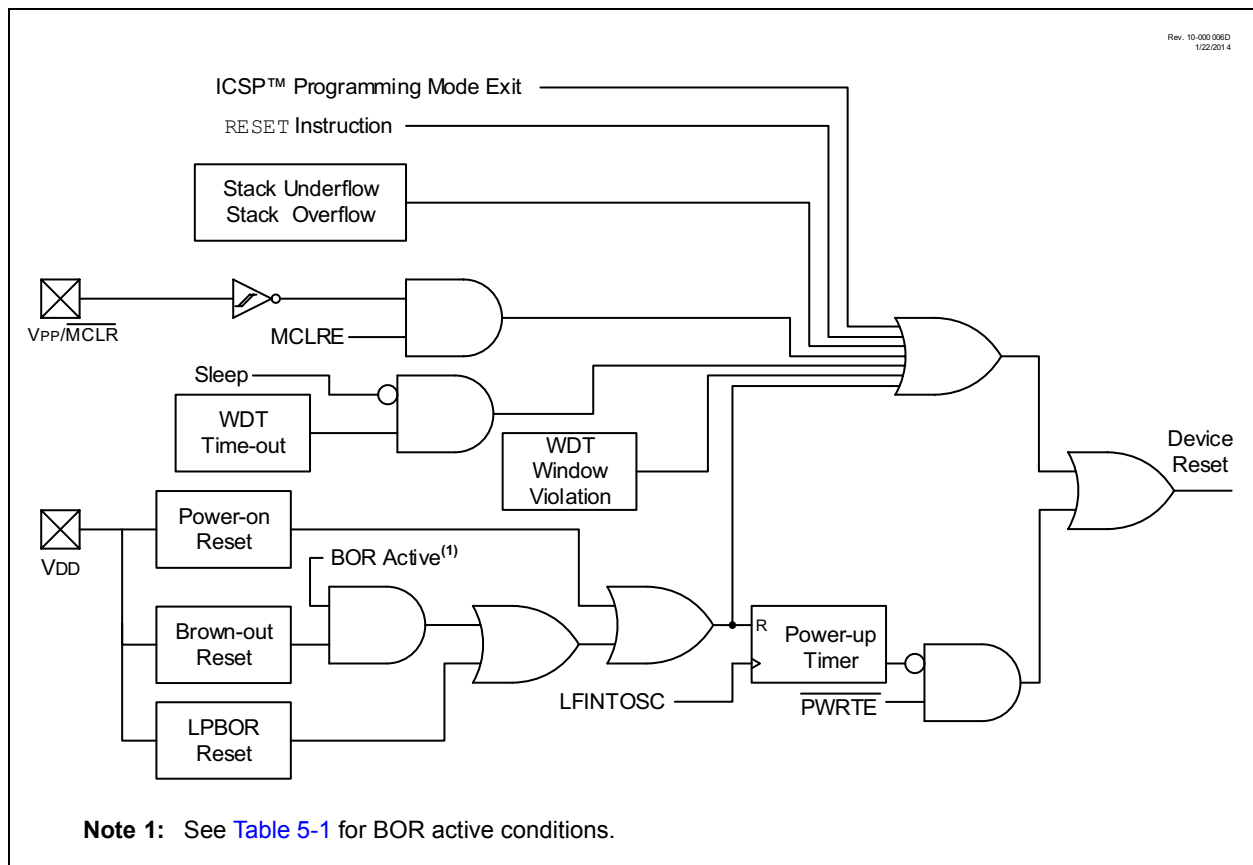

PIC16(L)F18856/76

5.1 Power-On Reset (POR)

The POR circuit holds the device in Reset until VDD has reached an acceptable level for minimum operation. Slow rising VDD, fast operating speeds or analog performance may require greater than minimum VDD. The PWRT, BOR or MCLR features can be used to extend the start-up period until all device operation conditions have been met.

5.2 Brown-Out Reset (BOR)

The BOR circuit holds the device in Reset when VDD reaches a selectable minimum level. Between the POR and BOR, complete voltage range coverage for execution protection can be implemented.

The Brown-out Reset module has four operating modes controlled by the BOREN<1:0> bits in Configuration Words. The four operating modes are:

- BOR is always on
- BOR is off when in Sleep
- BOR is controlled by software
- BOR is always off

Refer to [Table 5-1](#) for more information.

The Brown-out Reset voltage level is selectable by configuring the BORV bit in Configuration Words.

A VDD noise rejection filter prevents the BOR from triggering on small events. If VDD falls below VBOR for a duration greater than parameter TBORDC, the device will reset. See [Figure 5-2](#) for more information.

TABLE 5-1: BOR OPERATING MODES

BOREN<1:0>	SBOREN	Device Mode	BOR Mode	Instruction Execution upon: Release of POR or Wake-up from Sleep
11	x	X	Active	Wait for release of BOR ⁽¹⁾ (BORRDY = 1)
10	x	Awake	Active	Waits for release of BOR (BORRDY = 1) Waits for BOR Reset release
		Sleep	Disabled	
01	1	X	Active	Waits for BOR Reset release (BORRDY = 1) Begins immediately (BORRDY = x)
	0	X	Disabled	
00	x	X	Disabled	

Note 1: In these specific cases, “Release of POR” and “Wake-up from Sleep”, there is no delay in start-up. The BOR ready flag, (BORRDY = 1), will be set before the CPU is ready to execute instructions because the BOR circuit is forced on by the BOREN<1:0> bits.

5.2.1 BOR IS ALWAYS ON

When the BOREN bits of Configuration Words are programmed to ‘11’, the BOR is always on. The device start-up will be delayed until the BOR is ready and VDD is higher than the BOR threshold.

BOR protection is active during Sleep. The BOR does not delay wake-up from Sleep.

5.2.2 BOR IS OFF IN SLEEP

When the BOREN bits of Configuration Words are programmed to ‘10’, the BOR is on, except in Sleep. The device start-up will be delayed until the BOR is ready and VDD is higher than the BOR threshold.

BOR protection is not active during Sleep. The device wake-up will be delayed until the BOR is ready.

PIC16(L)F18856/76

5.2.3 BOR CONTROLLED BY SOFTWARE

When the BOREN bits of Configuration Words are programmed to '01', the BOR is controlled by the SBOREN bit of the BORCON register. The device start-up is not delayed by the BOR ready condition or the VDD level.

BOR protection begins as soon as the BOR circuit is ready. The status of the BOR circuit is reflected in the BORRDY bit of the BORCON register.

BOR protection is unchanged by Sleep.

5.2.4 BOR IS ALWAYS OFF

When the BOREN bits of the Configuration Words are programmed to '00', the BOR is off at all times. The device start-up is not delayed by the BOR ready condition or the VDD level.

FIGURE 5-2: BROWN-OUT SITUATIONS

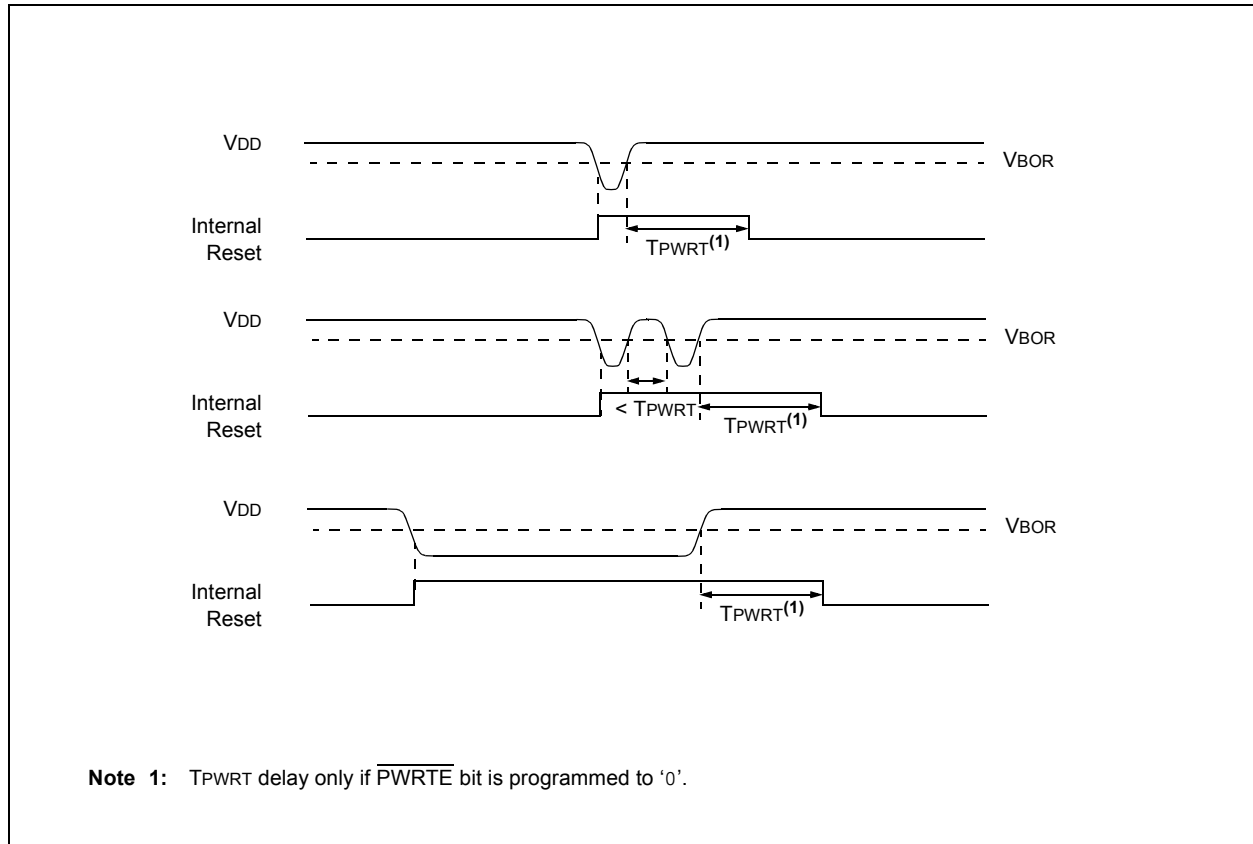

PIC16(L)F18856/76

5.3 Register Definitions: Brown-out Reset Control

REGISTER 5-1: BORCON: BROWN-OUT RESET CONTROL REGISTER

R/W-1/u	U-0	U-0	U-0	U-0	U-0	U-0	R-q/u
SBOREN ⁽¹⁾	—	—	—	—	—	—	BORRDY
bit 7							bit 0

Legend:

R = Readable bit	W = Writable bit	U = Unimplemented bit, read as '0'
u = Bit is unchanged	x = Bit is unknown	-n/n = Value at POR and BOR/Value at all other Resets
'1' = Bit is set	'0' = Bit is cleared	q = Value depends on condition

- bit 7 **SBOREN:** Software Brown-out Reset Enable bit⁽¹⁾
 If BOREN <1:0> in Configuration Words \neq 01:
 SBOREN is read/write, but has no effect on the BOR.
 If BOREN <1:0> in Configuration Words = 01:
 1 = BOR Enabled
 0 = BOR Disabled
- bit 6-1 **Unimplemented:** Read as '0'
- bit 0 **BORRDY:** Brown-out Reset Circuit Ready Status bit
 1 = The Brown-out Reset circuit is active
 0 = The Brown-out Reset circuit is inactive

Note 1: BOREN<1:0> bits are located in Configuration Words.

5.4 MCLR

The $\overline{\text{MCLR}}$ is an optional external input that can reset the device. The MCLR function is controlled by the MCLRE bit of Configuration Words and the LVP bit of Configuration Words (Table 5-2).

TABLE 5-2: MCLR CONFIGURATION

MCLRE	LVP	$\overline{\text{MCLR}}$
0	0	Disabled
1	0	Enabled
x	1	Enabled

5.4.1 MCLR ENABLED

When $\overline{\text{MCLR}}$ is enabled and the pin is held low, the device is held in Reset. The $\overline{\text{MCLR}}$ pin is connected to VDD through an internal weak pull-up.

The device has a noise filter in the $\overline{\text{MCLR}}$ Reset path. The filter will detect and ignore small pulses.

Note: A Reset does not drive the $\overline{\text{MCLR}}$ pin low.

5.4.2 MCLR DISABLED

When MCLR is disabled, the pin functions as a general purpose input and the internal weak pull-up is under software control. See Section 12.2 "I/O Priorities" for more information.

5.5 Windowed Watchdog Timer (WWDT) Reset

The Watchdog Timer generates a Reset if the firmware does not issue a CLRWDT instruction within the time-out period and the window is open. The $\overline{\text{TO}}$ and PD bits in the STATUS register and the WDT bit in PCON are changed to indicate a WDT Reset caused by the timer overflowing, and WDTWV bit in the PCON register is changed to indicate a WDT Reset caused by a window violation. See Section 9.0 "Windowed Watchdog Timer (WWDT)" for more information.

PIC16(L)F18856/76

5.6 RESET Instruction

A RESET instruction will cause a device Reset. The \overline{RI} bit in the PCON register will be set to '0'. See [Table 5-4](#) for default conditions after a RESET instruction has occurred.

5.7 Stack Overflow/Underflow Reset

The device can reset when the Stack Overflows or Underflows. The STKOVF or STKUNF bits of the PCON register indicate the Reset condition. These Resets are enabled by setting the STVREN bit in Configuration Words. See [Section 3.4.2 “Overflow/Underflow Reset”](#) for more information.

5.8 Programming Mode Exit

Upon exit of In-Circuit Serial Programming (ICSP) mode, the device will behave as if a POR had just occurred (the device does not reset upon run time self-programming/erase operations).

5.9 Power-Up Timer

The Power-up Timer optionally delays device execution after a BOR or POR event. This timer is typically used to allow VDD to stabilize before allowing the device to start running.

The Power-up Timer is controlled by the \overline{PWRT} bit of the Configuration Words.

The Power-up Timer provides a nominal 64 ms time out on POR or Brown-out Reset. The device is held in Reset as long as PWRT is active. The PWRT delay allows additional time for the VDD to rise to an acceptable level. The Power-up Timer is enabled by clearing the \overline{PWRT} bit in the Configuration Words. The Power-up Timer starts after the release of the POR and BOR. For additional information, refer to Application Note AN607, “Power-up Trouble Shooting” (DS00607).

5.10 Start-up Sequence

Upon the release of a POR or BOR, the following must occur before the device will begin executing:

1. Power-up Timer runs to completion (if enabled).
2. Oscillator start-up timer runs to completion (if required for oscillator source).
3. \overline{MCLR} must be released (if enabled).

The total time-out will vary based on oscillator configuration and Power-up Timer Configuration. See [Section 6.0 “Oscillator Module \(with Fail-Safe Clock Monitor\)”](#) for more information.

The Power-up Timer and oscillator start-up timer run independently of \overline{MCLR} Reset. If \overline{MCLR} is kept low long enough, the Power-up Timer and oscillator start-up timer will expire. Upon bringing \overline{MCLR} high, the device will begin execution after 10 FOSC cycles (see [Figure 5-3](#)). This is useful for testing purposes or to synchronize more than one device operating in parallel.

PIC16(L)F18856/76

FIGURE 5-3: RESET START-UP SEQUENCE

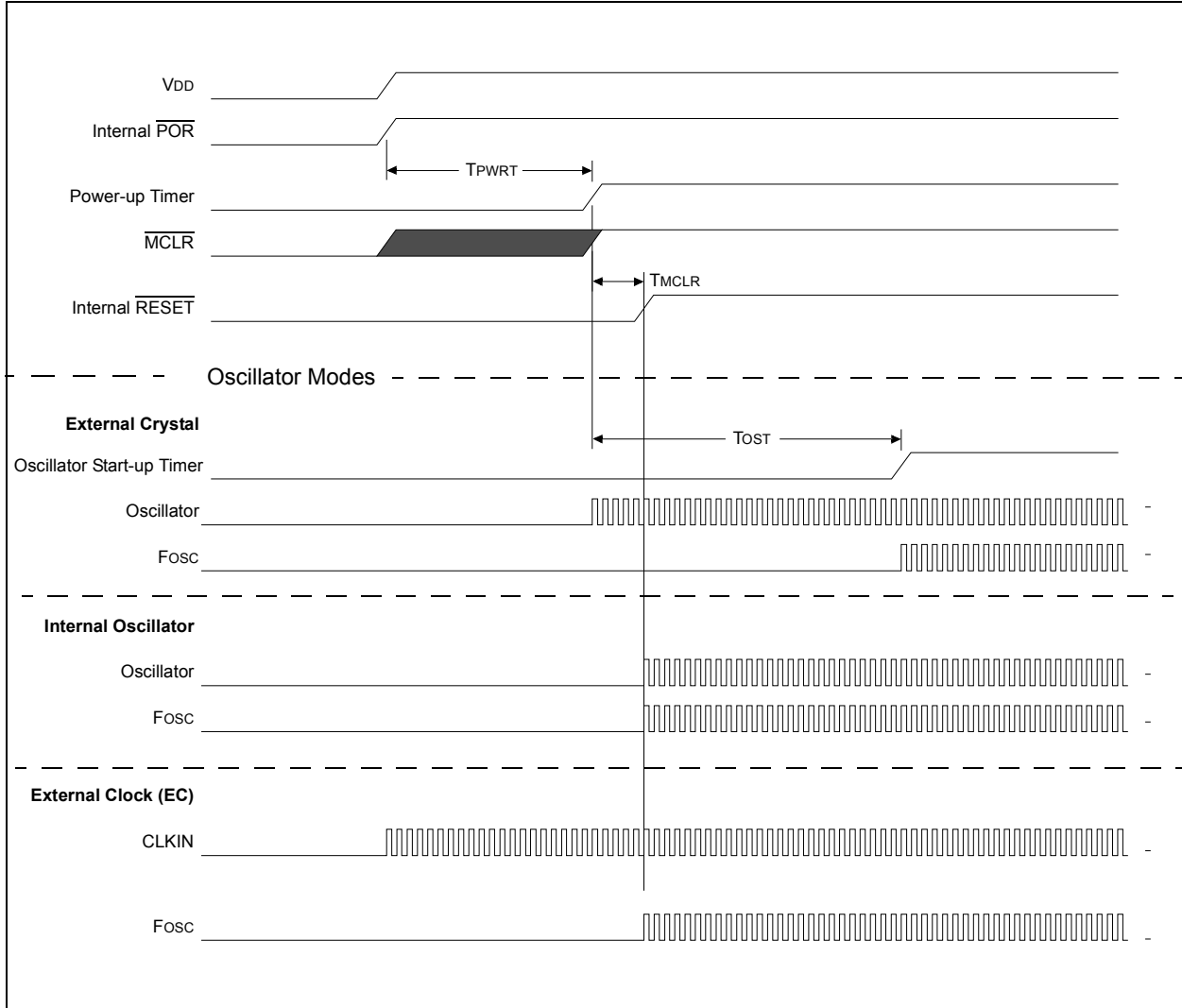

PIC16(L)F18856/76

5.11 Determining the Cause of a Reset

Upon any Reset, multiple bits in the STATUS and PCON register are updated to indicate the cause of the Reset. Table 5-3 and Table 5-4 show the Reset conditions of these registers.

TABLE 5-3: RESET STATUS BITS AND THEIR SIGNIFICANCE

STKOVF	STKUNF	RWD \overline{T}	RMCL \overline{R}	RI	POR	BOR	TO	PD	Condition
0	0	1	1	1	0	x	1	1	Power-on Reset
0	0	1	1	1	0	x	0	x	Illegal, \overline{TO} is set on \overline{POR}
0	0	1	1	1	0	x	x	0	Illegal, \overline{PD} is set on \overline{POR}
0	0	u	1	1	u	0	1	1	Brown-out Reset
u	u	0	u	u	u	u	0	u	WDT Reset
u	u	u	u	u	u	u	0	0	WDT Wake-up from Sleep
u	u	u	u	u	u	u	1	0	Interrupt Wake-up from Sleep
u	u	u	0	u	u	u	u	u	\overline{MCLR} Reset during normal operation
u	u	u	0	u	u	u	1	0	\overline{MCLR} Reset during Sleep
u	u	u	u	0	u	u	u	u	RESET Instruction Executed
1	u	u	u	u	u	u	u	u	Stack Overflow Reset (STVREN = 1)
u	1	u	u	u	u	u	u	u	Stack Underflow Reset (STVREN = 1)

TABLE 5-4: RESET CONDITION FOR SPECIAL REGISTERS

Condition	Program Counter	STATUS Register	PCON0 Register
Power-on Reset	0000h	---1 1000	00-- 110x
\overline{MCLR} Reset during normal operation	0000h	---u uuuu	uu-- 0uuu
\overline{MCLR} Reset during Sleep	0000h	---1 0uuu	uu-- 0uuu
WDT Reset	0000h	---0 uuuu	uu-0 uuuu
WDT Wake-up from Sleep	PC + 1	---0 0uuu	uu-u uuuu
WDT Window Violation	0000h	---0 uuuu	uu00 uuuu
Brown-out Reset	0000h	---1 1000	00-1 11u0
Interrupt Wake-up from Sleep	PC + 1 ⁽¹⁾	---1 0uuu	uu-u uuuu
RESET Instruction Executed	0000h	---u uuuu	uu-u u0uu
Stack Overflow Reset (STVREN = 1)	0000h	---u uuuu	1u-u uuuu
Stack Underflow Reset (STVREN = 1)	0000h	---u uuuu	u1-u uuuu

Legend: u = unchanged, x = unknown, - = unimplemented bit, reads as '0'.

Note 1: When the wake-up is due to an interrupt and Global Enable bit (GIE) is set, the return address is pushed on the stack and PC is loaded with the interrupt vector (0004h) after execution of PC + 1.

PIC16(L)F18856/76

5.12 Power Control (PCON) Register

The Power Control (PCON) register contains flag bits to differentiate between a:

- Power-on Reset ($\overline{\text{POR}}$)
- Brown-out Reset ($\overline{\text{BOR}}$)
- Reset Instruction Reset ($\overline{\text{RI}}$)
- MCLR Reset ($\overline{\text{RMCLR}}$)
- Watchdog Timer Reset ($\overline{\text{RWDT}}$)
- Watchdog Timer Window Violation Reset ($\overline{\text{WDTWV}}$)
- Stack Underflow Reset (STKUNF)
- Stack Overflow Reset (STKOVF)

The PCON0 register bits are shown in [Register 5-2](#).

Hardware will change the corresponding register bit during the Reset process; if the Reset was not caused by the condition, the bit remains unchanged ([Table 5-4](#)).

Software should reset the bit to the inactive state after the restart (hardware will not reset the bit).

Software may also set any PCON bit to the active state, so that user code may be tested, but no reset action will be generated.

PIC16(L)F18856/76

5.13 Register Definitions: Power Control

REGISTER 5-2: PCON0: POWER CONTROL REGISTER 0

R/W/HS-0/q	R/W/HS-0/q	R/W/HC-1/q	R/W/HC-1/q	R/W/HC-1/q	R/W/HC-1/q	R/W/HC-q/u	R/W/HC-q/u
STKOVF	STKUNF	WDTWV	RWDT	RMCLR	RI	POR	BOR
bit 7							bit 0

Legend:

HC = Bit is cleared by hardware	HS = Bit is set by hardware
R = Readable bit	W = Writable bit
u = Bit is unchanged	x = Bit is unknown
'1' = Bit is set	'0' = Bit is cleared
	U = Unimplemented bit, read as '0'
	-m/n = Value at POR and BOR/Value at all other Resets
	q = Value depends on condition

- bit 7 **STKOVF:** Stack Overflow Flag bit
 1 = A Stack Overflow occurred
 0 = A Stack Overflow has not occurred or cleared by firmware
- bit 6 **STKUNF:** Stack Underflow Flag bit
 1 = A Stack Underflow occurred
 0 = A Stack Underflow has not occurred or cleared by firmware
- bit 5 **WDTWV:** WDT Window Violation Flag bit
 1 = A WDT Window Violation Reset has not occurred or set by firmware
 0 = A WDT Window Violation Reset has occurred (a CLRWD \overline{T} instruction was executed either without arming the window or outside the window (cleared by hardware))
- bit 4 **RWDT:** Watchdog Timer Reset Flag bit
 1 = A Watchdog Timer Reset has not occurred or set to '1' by firmware
 0 = A Watchdog Timer Reset has occurred (cleared by hardware)
- bit 3 **RMCLR:** MCLR Reset Flag bit
 1 = A MCLR Reset has not occurred or set to '1' by firmware
 0 = A MCLR Reset has occurred (cleared by hardware)
- bit 2 **RI:** RESET Instruction Flag bit
 1 = A RESET instruction has not been executed or set to '1' by firmware
 0 = A RESET instruction has been executed (cleared by hardware)
- bit 1 **POR:** Power-on Reset Status bit
 1 = No Power-on Reset occurred
 0 = A Power-on Reset occurred (must be set in software after a Power-on Reset occurs)
- bit 0 **BOR:** Brown-out Reset Status bit
 1 = No Brown-out Reset occurred
 0 = A Brown-out Reset occurred (must be set in software after a Power-on Reset or Brown-out Reset occurs)

TABLE 5-5: SUMMARY OF REGISTERS ASSOCIATED WITH RESETS

Name	Bit 7	Bit 6	Bit 5	Bit 4	Bit 3	Bit 2	Bit 1	Bit 0	Register on Page
BORCON	SBOREN	—	—	—	—	—	—	BORRDY	104
PCON0	STKOVF	STKUNF	WDTWV	RWDT	RMCLR	RI	POR	BOR	109
STATUS	—	—	—	TO	PD	Z	DC	C	38
WDTCON0	—	—	WDTPS<4:0>					SWDTEN	166

Legend: — = unimplemented location, read as '0'. Shaded cells are not used by Resets.

PIC16(L)F18856/76

6.0 OSCILLATOR MODULE (WITH FAIL-SAFE CLOCK MONITOR)

6.1 Overview

The oscillator module has a wide variety of clock sources and selection features that allow it to be used in a wide range of applications while maximizing performance and minimizing power consumption. [Figure 6-1](#) illustrates a block diagram of the oscillator module.

Clock sources can be supplied from external oscillators, quartz-crystal resonators and ceramic resonators. In addition, the system clock source can be supplied from one of two internal oscillators and PLL circuits, with a choice of speeds selectable via software. Additional clock features include:

- Selectable system clock source between external or internal sources via software.
- Fail-Safe Clock Monitor (FSCM) designed to detect a failure of the external clock source (LP, XT, HS, ECH, ECM, ECL) and switch automatically to the internal oscillator.
- Oscillator Start-up Timer (OST) ensures stability of crystal oscillator sources.

The RSTOSC bits of Configuration Word 1 determine the type of oscillator that will be used when the device reset, including when it is first powered up.

The internal clock modes, LFINTOSC, HFINTOSC (set at 1 MHz), or HFINTOSC (set at 32 MHz) can be set through the RSTOSC bits.

If an external clock source is selected, the FEXTOSC bits of Configuration Word 1 must be used in conjunction with the RSTOSC bits to select the external clock mode.

The external oscillator module can be configured in one of the following clock modes, by setting the FEXTOSC<2:0> bits of Configuration Word 1:

1. ECL – External Clock Low-Power mode (below 500 kHz)
2. ECM – External Clock Medium Power mode (500 kHz to 8 MHz)
3. ECH – External Clock High-Power mode (above 8 MHz)
4. LP – 32 kHz Low-Power Crystal mode.
5. XT – Medium Gain Crystal or Ceramic Resonator Oscillator mode (between 100 kHz and 4 MHz)
6. HS – High Gain Crystal or Ceramic Resonator mode (above 4 MHz)

The ECH, ECM, and ECL clock modes rely on an external logic level signal as the device clock source. The LP, XT, and HS clock modes require an external crystal or resonator to be connected to the device. Each mode is optimized for a different frequency range. The INTOSC internal oscillator block produces low and high-frequency clock sources, designated LFINTOSC and HFINTOSC. (see Internal Oscillator Block, [Figure 6-1](#)). A wide selection of device clock frequencies may be derived from these clock sources.

FIGURE 6-1: SIMPLIFIED PIC® MCU CLOCK SOURCE BLOCK DIAGRAM

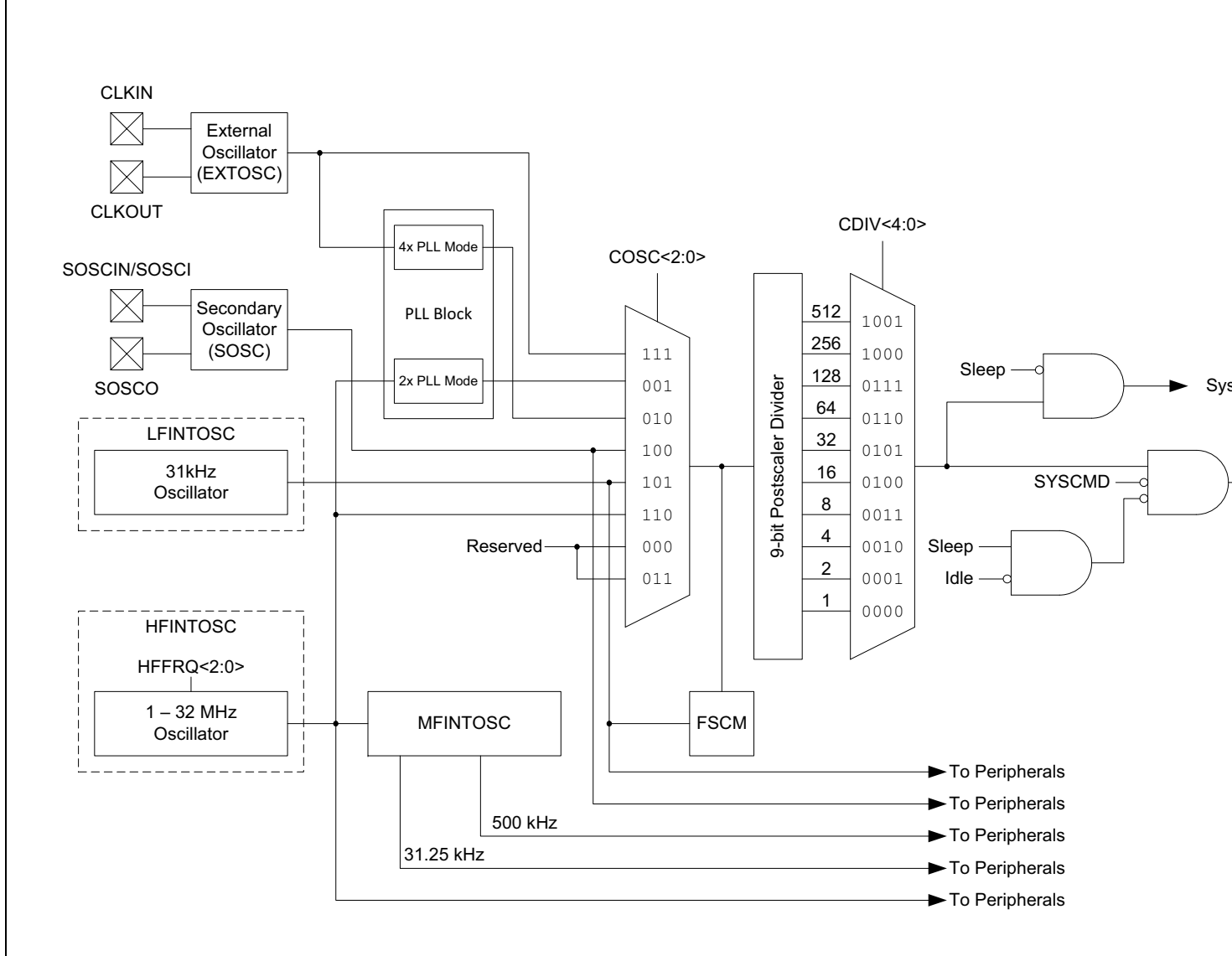

PIC16(L)F18856/76

6.2 Clock Source Types

Clock sources can be classified as external or internal.

External clock sources rely on external circuitry for the clock source to function. Examples are: oscillator modules (ECH, ECM, ECL mode), quartz crystal resonators or ceramic resonators (LP, XT and HS modes).

Internal clock sources are contained within the oscillator module. The internal oscillator block has two internal oscillators and a dedicated Phase Lock Loop (PLL) that are used to generate internal system clock sources. The High-Frequency Internal Oscillator (HFINTOSC) can produce a range from 1 to 32 MHz. The Low-Frequency Internal Oscillator (LFINTOSC) generates a 31 kHz frequency. The external oscillator block can also be used with the PLL. See [Section 6.2.1.4 “4x PLL”](#) for more details.

The system clock can be selected between external or internal clock sources via the NOSC bits in the OSCCON1 register. See [Section 6.3 “Clock Switching”](#) for additional information.

6.2.1 EXTERNAL CLOCK SOURCES

An external clock source can be used as the device system clock by performing one of the following actions:

- Program the RSTOSC<2:0> bits in the Configuration Words to select an external clock source that will be used as the default system clock upon a device Reset
- Write the NOSC<2:0> and NDIV<4:0> bits in the OSCCON1 register to switch the system clock source

See [Section 6.3 “Clock Switching”](#) for more information.

6.2.1.1 EC Mode

The External Clock (EC) mode allows an externally generated logic level signal to be the system clock source. When operating in this mode, an external clock source is connected to the OSC1 input. OSC2/CLKOUT is available for general purpose I/O or CLKOUT. [Figure 6-2](#) shows the pin connections for EC mode.

EC mode has three power modes to select from through Configuration Words:

- ECH – High power, 4-32 MHz
- ECM – Medium power, 0.1-4 MHz
- ECL – Low power, 0-0.1 MHz

The Oscillator Start-up Timer (OST) is disabled when EC mode is selected. Therefore, there is no delay in operation after a Power-on Reset (POR) or wake-up from Sleep. Because the PIC® MCU design is fully static, stopping the external clock input will have the effect of halting the device while leaving all data intact. Upon restarting the external clock, the device will resume operation as if no time had elapsed.

FIGURE 6-2: EXTERNAL CLOCK (EC) MODE OPERATION

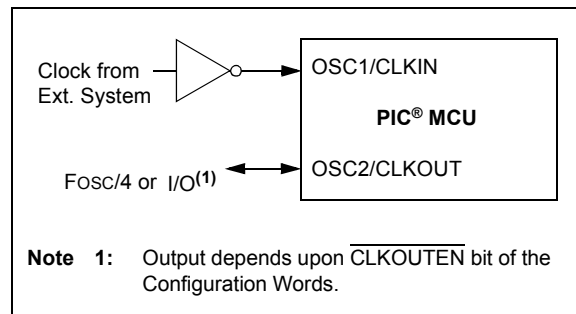

6.2.1.2 LP, XT, HS Modes

The LP, XT and HS modes support the use of quartz crystal resonators or ceramic resonators connected to OSC1 and OSC2 ([Figure 6-3](#)). The three modes select a low, medium or high gain setting of the internal inverter-amplifier to support various resonator types and speed.

LP Oscillator mode selects the lowest gain setting of the internal inverter-amplifier. LP mode current consumption is the least of the three modes. This mode is designed to drive only 32.768 kHz tuning-fork type crystals (watch crystals).

XT Oscillator mode selects the intermediate gain setting of the internal inverter-amplifier. XT mode current consumption is the medium of the three modes. This mode is best suited to drive resonators with a medium drive level specification.

HS Oscillator mode selects the highest gain setting of the internal inverter-amplifier. HS mode current consumption is the highest of the three modes. This mode is best suited for resonators that require a high drive setting.

[Figure 6-3](#) and [Figure 6-4](#) show typical circuits for quartz crystal and ceramic resonators, respectively.

PIC16(L)F18856/76

FIGURE 6-3: QUARTZ CRYSTAL OPERATION (LP, XT OR HS MODE)

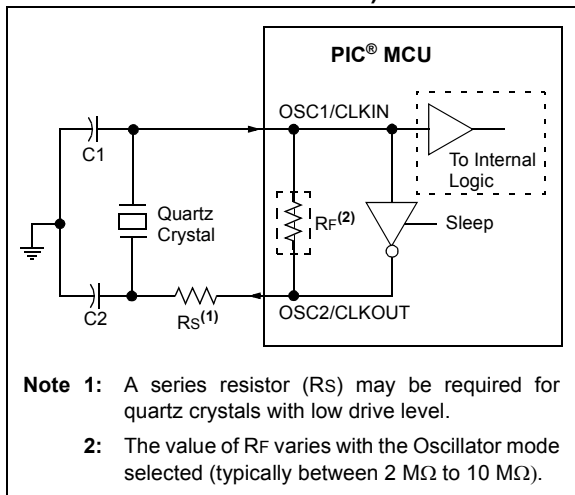

Note 1: Quartz crystal characteristics vary according to type, package and manufacturer. The user should consult the manufacturer data sheets for specifications and recommended application.

- 2:** Always verify oscillator performance over the V_{DD} and temperature range that is expected for the application.
- 3:** For oscillator design assistance, reference the following Microchip Application Notes:

- AN826, "Crystal Oscillator Basics and Crystal Selection for *rPIC*[®] and *PIC*[®] Devices" (DS00826)
- AN849, "Basic *PIC*[®] Oscillator Design" (DS00849)
- AN943, "Practical *PIC*[®] Oscillator Analysis and Design" (DS00943)
- AN949, "Making Your Oscillator Work" (DS00949)

FIGURE 6-4: CERAMIC RESONATOR OPERATION (XT OR HS MODE)

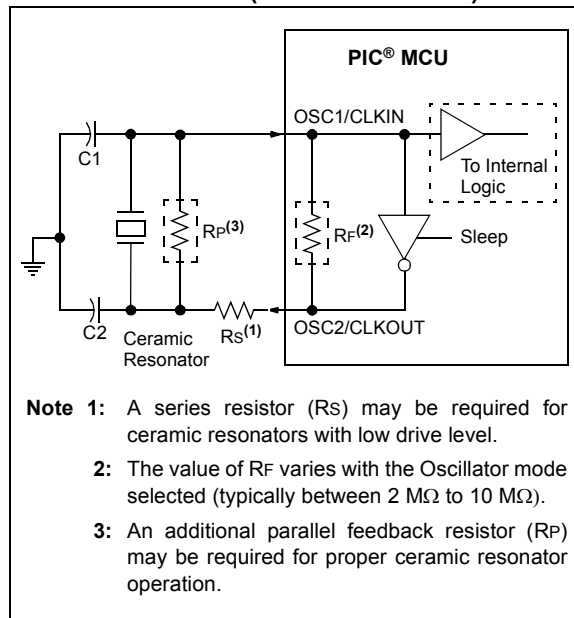

6.2.1.3 Oscillator Start-up Timer (OST)

If the oscillator module is configured for LP, XT or HS modes, the Oscillator Start-up Timer (OST) counts 1024 oscillations from OSC1. This occurs following a Power-on Reset (POR), or a wake-up from Sleep. The OST ensures that the oscillator circuit, using a quartz crystal resonator or ceramic resonator, has started and is providing a stable system clock to the oscillator module.

PIC16(L)F18856/76

6.2.1.4 4x PLL

The oscillator module contains a PLL that can be used with external clock sources to provide a system clock source. The input frequency for the PLL must fall within specifications. See the PLL Clock Timing Specifications in [Table 37-9](#).

The PLL may be enabled for use by one of two methods:

1. Program the RSTOSC bits in the Configuration Word 1 to enable the EXTOSC with 4x PLL.
2. Write the NOSC bits in the OSCCON1 register to enable the EXTOSC with 4x PLL.

6.2.1.5 Secondary Oscillator

The secondary oscillator is a separate oscillator block that can be used as an alternate system clock source. The secondary oscillator is optimized for 31 kHz, and can be used with an external crystal oscillator connected to the SOSC1 and SOSCO device pins, or an external clock source connected to the SOSCIN pin. The secondary oscillator can be selected during run-time using clock switching. Refer to [Section 6.3 “Clock Switching”](#) for more information.

FIGURE 6-5: QUARTZ CRYSTAL OPERATION (SECONDARY OSCILLATOR)

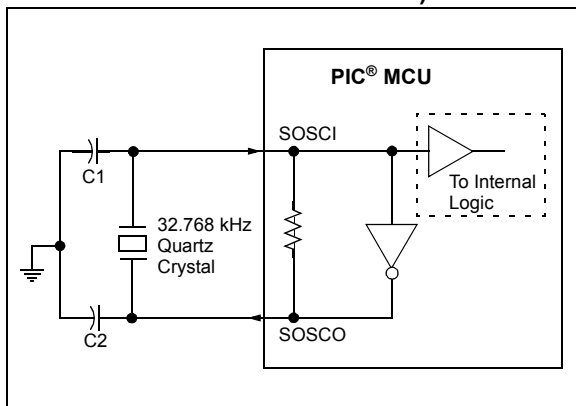

Note 1: Quartz crystal characteristics vary according to type, package and manufacturer. The user should consult the manufacturer data sheets for specifications and recommended application.

2: Always verify oscillator performance over the V_{DD} and temperature range that is expected for the application.

3: For oscillator design assistance, reference the following Microchip Application Notes:

- AN826, “Crystal Oscillator Basics and Crystal Selection for rPIC[®] and PIC[®] Devices” (DS00826)
- AN849, “Basic PIC[®] Oscillator Design” (DS00849)
- AN943, “Practical PIC[®] Oscillator Analysis and Design” (DS00943)
- AN949, “Making Your Oscillator Work” (DS00949)
- TB097, “Interfacing a Micro Crystal MS1V-T1K 32.768 kHz Tuning Fork Crystal to a PIC16F690/SS” (DS91097)
- AN1288, “Design Practices for Low-Power External Oscillators” (DS01288)

PIC16(L)F18856/76

6.2.2 INTERNAL CLOCK SOURCES

The device may be configured to use the internal oscillator block as the system clock by performing one of the following actions:

- Program the RSTOSC<2:0> bits in Configuration Words to select the INTOSC clock source, which will be used as the default system clock upon a device Reset.
- Write the NOSC<2:0> bits in the OSCCON1 register to switch the system clock source to the internal oscillator during run-time. See [Section 6.3 “Clock Switching”](#) for more information.

In **INTOSC** mode, OSC1/CLKIN is available for general purpose I/O. OSC2/CLKOUT is available for general purpose I/O or CLKOUT.

The function of the OSC2/CLKOUT pin is determined by the CLKOUTEN bit in Configuration Words.

The internal oscillator block has two independent oscillators that can produce two internal system clock sources.

1. The **HFINTOSC** (High-Frequency Internal Oscillator) is factory calibrated and operates up to 32 MHz. The frequency of HFINTOSC can be selected through the OSCFRQ Frequency Selection register, and fine-tuning can be done via the OSCTUNE register.
2. The **LFINTOSC** (Low-Frequency Internal Oscillator) is factory-calibrated and operates at 31 kHz.

6.2.2.1 HFINTOSC

The High-Frequency Internal Oscillator (HFINTOSC) is a precision digitally-controlled internal clock source that produces a stable clock up to 32 MHz. The HFINTOSC can be enabled through one of the following methods:

- Programming the RSTOSC<2:0> bits in Configuration Word 1 to '110' (1 MHz) or '000' (32 MHz) to set the oscillator upon device Power-up or Reset.
- Write to the NOSC<2:0> bits of the OSCCON1 register during run-time.

The HFINTOSC frequency can be selected by setting the HFFRQ<2:0> bits of the OSCFRQ register.

The NDIV<3:0> bits of the OSCCON1 register allow for division of the HFINTOSC output from a range between 1:1 and 1:512.

PIC16(L)F18856/76

6.2.2.2 Internal Oscillator Frequency Adjustment

The internal oscillator is factory-calibrated. This internal oscillator can be adjusted in software by writing to the OSCTUNE register ([Register 6-7](#)).

The default value of the OSCTUNE register is 00h. The value is a 6-bit two's complement number. A value of 1Fh will provide an adjustment to the maximum frequency. A value of 20h will provide an adjustment to the minimum frequency.

When the OSCTUNE register is modified, the oscillator frequency will begin shifting to the new frequency. Code execution continues during this shift. There is no indication that the shift has occurred.

OSCTUNE does not affect the LFINTOSC frequency. Operation of features that depend on the LFINTOSC clock source frequency, such as the Power-up Timer (PWRT), Watchdog Timer (WDT), Fail-Safe Clock Monitor (FSCM) and peripherals, are *not* affected by the change in frequency.

6.2.2.3 LFINTOSC

The Low-Frequency Internal Oscillator (LFINTOSC) is a factory calibrated 31 kHz internal clock source.

The LFINTOSC is the frequency for the Power-up Timer (PWRT), Watchdog Timer (WDT) and Fail-Safe Clock Monitor (FSCM).

The LFINTOSC is enabled through one of the following methods:

- Programming the RSTOSC<2:0> bits of Configuration Word 1 to enable LFINTOSC.
- Write to the NOSC<2:0> bits of the OSCCON1 register.

Peripherals that use the LFINTOSC are:

- Power-up Timer (PWRT)
- Watchdog Timer (WDT)
- TMR1
- TMR0
- TMR2
- SMT1
- SMT2
- CLKREF
- CLC

6.2.2.4 MFINTOSC

In addition to the two independent internal oscillators, the internal oscillator block also contains a divider block called MFINTOSC, to supply certain specific frequencies to other modules on the device. The MFINTOSC module takes the undivided HFINTOSC clock as an input and outputs two clocks, a 500 kHz clock (MFINTOSC) and a 31.25 kHz clock (MFINTOSC/16).

The MFINTOSC is enabled through one of the following methods:

- Setting the MFOEN bit of OSCEN (see [Section 6.2.2.5 “Oscillator Status and Manual Enable”](#))
- Selecting MFINTOSC or MFINTOSC/16 as an input clock for one of the peripherals that uses the clock.

Peripherals that use the MFINTOSC output (500 kHz) are:

- TMR1
- TMR3
- TMR5
- SMT1
- SMT2
- CLKREF

Peripherals that use the MFINTOSC/16 output (31.25 kHz) are:

- WDT
- TMR2
- TMR4
- TMR6
- SMT1
- SMT2
- CLKREF

Note: Enabling the MFINTOSC will also enable the HFINTOSC.

6.2.2.5 Oscillator Status and Manual Enable

The 'ready' status of each oscillator is displayed in the OSCSTAT register ([Register 6-4](#)). The oscillators can also be manually enabled through the OSCEN register ([Register 6-7](#)). Manual enabling makes it possible to verify the operation of the EXTOSC or SOSC crystal oscillators. This can be achieved by enabling the selected oscillator, then watching the corresponding 'ready' state of the oscillator in the OSCSTAT register.

PIC16(L)F18856/76

6.3 Clock Switching

The system clock source can be switched between external and internal clock sources via software using the New Oscillator Source (NOSC) and New Divider selection request (NDIV) bits of the OSCCON1 register. The following clock sources can be selected using the following:

- External oscillator
- Internal Oscillator Block (INTOSC)

6.3.1 NEW OSCILLATOR SOURCE (NOSC) AND NEW DIVIDER SELECTION REQUEST (NDIV) BITS

The New Oscillator Source (NOSC) and New Divider selection request (NDIV) bits of the OSCCON1 register select the system clock source that is used for the CPU and peripherals.

When new values of NOSC and NDIV are written to OSCCON1, the current oscillator selection will continue to operate while waiting for the new clock source to indicate that it is stable and ready. In some cases, the newly requested source may already be in use, and is ready immediately. In the case of a divider-only change, the new and old sources are the same, so the old source will be ready immediately. The device may enter Sleep while waiting for the switch as described in [Section 6.3.3, Clock Switch and Sleep](#).

When the new oscillator is ready, the New Oscillator is Ready (NOSCR) bit of OSCCON3 and the Clock Switch Interrupt Flag (CSWIF) bit of PIR1 become set (CSWIF = 1). If Clock Switch Interrupts are enabled (CLKSIE = 1), an interrupt will be generated at that time. The Oscillator Ready (ORDY) bit of OSCCON3 can also be polled to determine when the oscillator is ready in lieu of an interrupt.

If the Clock Switch Hold (CSWHOLD) bit of OSCCON3 is clear, the oscillator switch will occur when the New Oscillator is ready bit (NOSCR) is set, and the interrupt (if enabled) will be serviced at the new oscillator setting.

If CSWHOLD is set, the oscillator switch is suspended, while execution continues using the current (old) clock source. When the NOSCR bit is set, software should:

- Set CSWHOLD = 0 so the switch can complete, or
- Copy COSC into NOSC to abandon the switch.

If DOZE is in effect, the switch occurs on the next clock cycle, whether or not the CPU is operating during that cycle.

Changing the clock post-divider without changing the clock source (i.e., changing Fosc from 1 MHz to 2 MHz) is handled in the same manner as a clock source change, as described previously. The clock source will already be active, so the switch is relatively quick. CSWHOLD must be clear (CSWHOLD = 0) for the switch to complete.

The current COSC and CDIV are indicated in the OSCCON2 register up to the moment when the switch actually occurs, at which time OSCCON2 is updated and ORDY is set. NOSCR is cleared by hardware to indicate that the switch is complete.

6.3.2 PLL INPUT SWITCH

Switching between the PLL and any non-PLL source is managed as described above. The input to the PLL is established when NOSC selects the PLL, and maintained by the COSC setting.

When NOSC and COSC select the PLL with different input sources, the system continues to run using the COSC setting, and the new source is enabled per NOSC. When the new oscillator is ready (and CSWHOLD = 0), system operation is suspended while the PLL input is switched and the PLL acquires lock.

Note: If the PLL fails to lock, the FSCM will trigger.

6.3.3 CLOCK SWITCH AND SLEEP

If OSCCON1 is written with a new value and the device is put to Sleep before the switch completes, the switch will not take place and the device will enter Sleep mode.

When the device wakes from Sleep and the CSWHOLD bit is clear, the device will wake with the 'new' clock active, and the clock switch interrupt flag bit (CSWIF) will be set.

When the device wakes from Sleep and the CSWHOLD bit is set, the device will wake with the 'old' clock active and the new clock will be requested again.

PIC16(L)F18856/76

FIGURE 6-6: CLOCK SWITCH (CSWHOLD = 0)

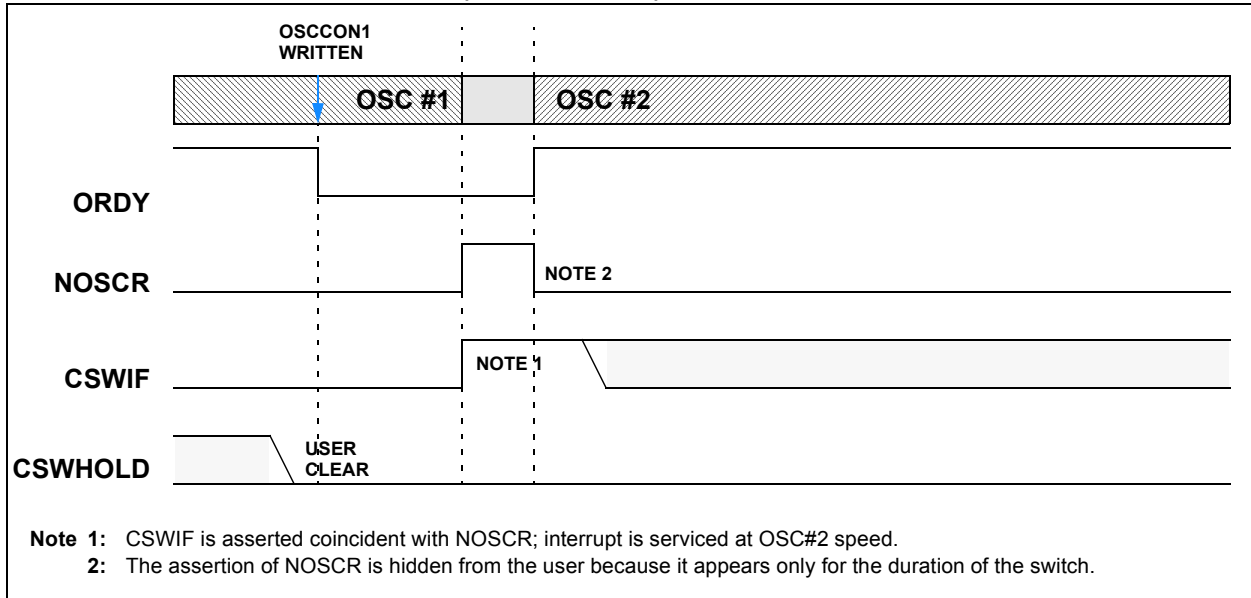
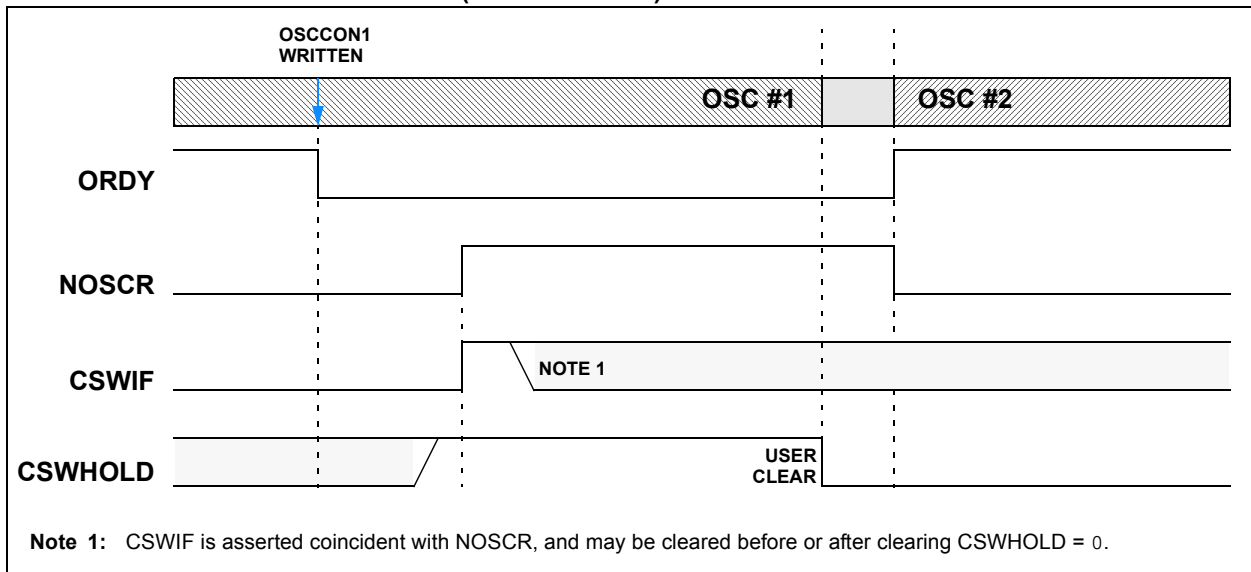
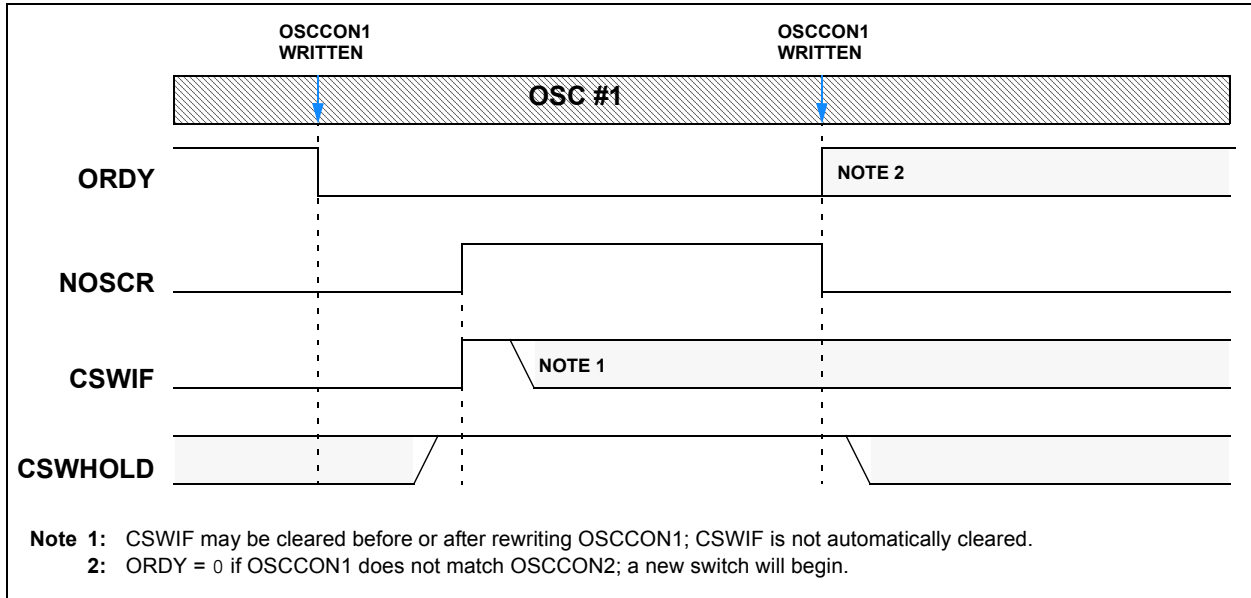

FIGURE 6-7: CLOCK SWITCH (CSWHOLD = 1)



PIC16(L)F18856/76

FIGURE 6-8: CLOCK SWITCH ABANDONED



PIC16(L)F18856/76

6.4 Fail-Safe Clock Monitor

The Fail-Safe Clock Monitor (FSCM) allows the device to continue operating should the external oscillator fail. The FSCM is enabled by setting the FCMEN bit in the Configuration Words. The FSCM is applicable to all external Oscillator modes (LP, XT, HS, EC and Secondary Oscillator).

FIGURE 6-9: FSCM BLOCK DIAGRAM

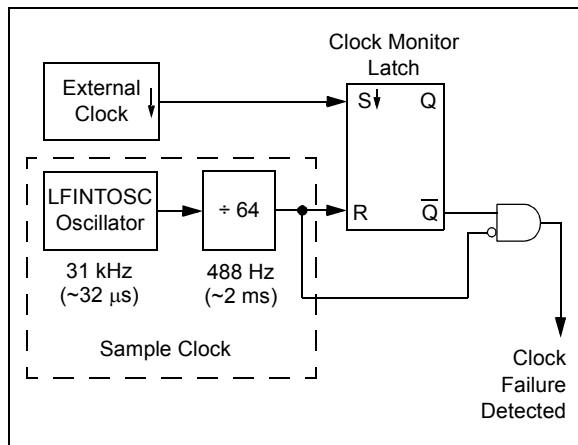

6.4.1 FAIL-SAFE DETECTION

The FSCM module detects a failed oscillator by comparing the external oscillator to the FSCM sample clock. The sample clock is generated by dividing the LFINTOSC by 64. See [Figure 6-9](#). Inside the fail detector block is a latch. The external clock sets the latch on each falling edge of the external clock. The sample clock clears the latch on each rising edge of the sample clock. A failure is detected when an entire half-cycle of the sample clock elapses before the external clock goes low.

6.4.2 FAIL-SAFE OPERATION

When the external clock fails, the FSCM switches the device clock to the HFINTOSC at 1 MHz clock frequency and sets the bit flag OSFIF of the PIR1 register. Setting this flag will generate an interrupt if the OSFIE bit of the PIE1 register is also set. The device firmware can then take steps to mitigate the problems that may arise from a failed clock. The system clock will continue to be sourced from the internal clock source until the device firmware successfully restarts the external oscillator and switches back to external operation, by writing to the NOSC and NDIV bits of the OSCCON1 register.

6.4.3 FAIL-SAFE CONDITION CLEARING

The Fail-Safe condition is cleared after a Reset, executing a `SLEEP` instruction or changing the NOSC and NDIV bits of the OSCCON1 register. When switching to the external oscillator or PLL, the OST is restarted. While the OST is running, the device continues to operate from the INTOSC selected in OSCCON1. When the OST times out, the Fail-Safe condition is cleared after successfully switching to the external clock source. The OSFIF bit should be cleared prior to switching to the external clock source. If the Fail-Safe condition still exists, the OSFIF flag will again become set by hardware.

PIC16(L)F18856/76

6.4.4 RESET OR WAKE-UP FROM SLEEP

The FSCM is designed to detect an oscillator failure after the Oscillator Start-up Timer (OST) has expired. The OST is used after waking up from Sleep and after any type of Reset. The OST is not used with the EC Clock modes so that the FSCM will be active as soon as the Reset or wake-up has completed. Therefore, the device will always be executing code while the OST is operating.

FIGURE 6-10: FSCM TIMING DIAGRAM

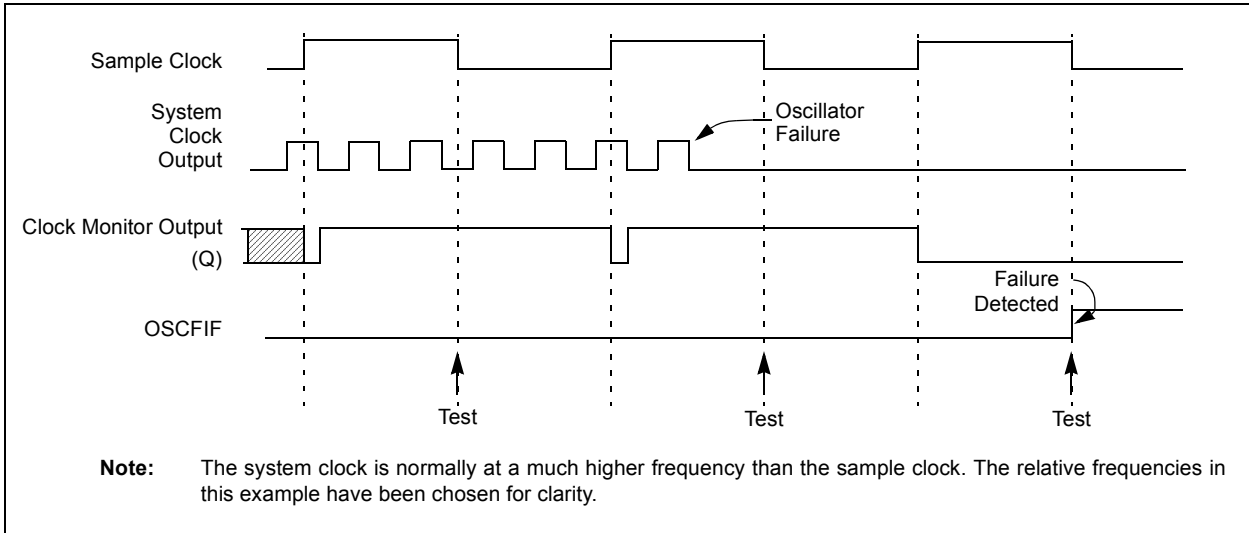

PIC16(L)F18856/76

6.5 Register Definitions: Oscillator Control

REGISTER 6-1: OSCCON1: OSCILLATOR CONTROL REGISTER1

U-0	R/W-f/f ⁽¹⁾	R/W-f/f ⁽¹⁾	R/W-f/f ⁽¹⁾	R/W-q/q	R/W-q/q	R/W-q/q	R/W-q/q
—	NOSC<2:0> ^(2,3)			NDIV<3:0> ^(2,3,4)			
bit 7							bit 0

Legend:

R = Readable bit	W = Writable bit	U = Unimplemented bit, read as '0'
u = Bit is unchanged	x = Bit is unknown	-n/n = Value at POR and BOR/Value at all other Resets
'1' = Bit is set	'0' = Bit is cleared	f = determined by fuse setting

bit 7 **Unimplemented:** Read as '0'

bit 6-4 **NOSC<2:0>:** New Oscillator Source Request bits
The setting requests a source oscillator and PLL combination per [Table 6-1](#).
POR value = RSTOSC ([Register 4-1](#)).

bit 3-0 **NDIV<3:0>:** New Divider Selection Request bits
The setting determines the new postscaler division ratio per [Table 6-1](#).

- Note 1:** The default value (f/f) is set equal to the RSTOSC Configuration bits.
Note 2: If NOSC is written with a reserved value ([Table 6-1](#)), the operation is ignored and neither NOSC nor NDIV is written.
Note 3: When CSWEN = 0, this register is read-only and cannot be changed from the POR value.
Note 4: When NOSC = 110 (HFINTOSC 4 MHz), the NDIV bits will default to '0010' upon Reset; for all other NOSC settings the NDIV bits will default to '0000' upon Reset.

REGISTER 6-2: OSCCON2: OSCILLATOR CONTROL REGISTER 2

U-0	R-n/n ⁽²⁾	R-n/n ⁽²⁾	R-n/n ⁽²⁾	R-n/n ⁽²⁾	R-n/n ⁽²⁾	R-n/n ⁽²⁾	R-n/n ⁽²⁾
—	COSC<2:0>			CDIV<3:0>			
bit 7							bit 0

Legend:

R = Readable bit	W = Writable bit	U = Unimplemented bit, read as '0'
u = Bit is unchanged	x = Bit is unknown	-n/n = Value at POR and BOR/Value at all other Resets
'1' = Bit is set	'0' = Bit is cleared	

bit 7 **Unimplemented:** Read as '0'

bit 6-4 **COSC<2:0>:** Current Oscillator Source Select bits (read-only)
Indicates the current source oscillator and PLL combination per [Table 6-1](#).

bit 3-0 **CDIV<3:0>:** Current Divider Select bits (read-only)
Indicates the current postscaler division ratio per [Table 6-1](#).

- Note 1:** The POR value is the value present when user code execution begins.
Note 2: The reset value (n/n) is the same as the NOSC/NDIV bits.

PIC16(L)F18856/76

TABLE 6-1: NOSC/COSC BIT SETTINGS

NOSC<2:0>/ COSC<2:0>	Clock Source
111	EXTOSC ⁽¹⁾
110	HFINTOSC ⁽²⁾
101	LFINTOSC
100	SOSC
011	Reserved (it operates like NOSC = 110)
010	EXTOSC with 4x PLL ⁽¹⁾
001	HFINTOSC with 2x PLL ⁽¹⁾
000	Reserved (it operates like NOSC = 110)

- Note** 1: EXTOSC configured by the FEXTOSC bits of Configuration Word 1 (Register 4-1).
 2: HFINTOSC settings are configured with the HFFRQ bits of the OSCFRQ register (Register 6-6).

TABLE 6-2: NDIV/CDIV BIT SETTINGS

NDIV<3:0>/ CDIV<3:0>	Clock divider
1111-1010	Reserved
1001	512
1000	256
0111	128
0110	64
0101	32
0100	16
0011	8
0010	4
0001	2
0000	1

REGISTER 6-3: OSCCON3: OSCILLATOR CONTROL REGISTER 3

R/W/HC-0/0	R/W-0/0	U-0	R-0/0	R-0/0	U-0	U-0	U-0
CSWHOLD	SOSCPWR	—	ORDY	NOSCR	—	—	—
bit 7							bit 0

Legend:

R = Readable bit W = Writable bit U = Unimplemented bit, read as '0'
 u = Bit is unchanged x = Bit is unknown -n/n = Value at POR and BOR/Value at all other Resets
 '1' = Bit is set '0' = Bit is cleared HC = Bit is cleared by hardware

- bit 7 **CSWHOLD:** Clock Switch Hold bit
 1 = Clock switch will hold (with interrupt) when the oscillator selected by NOSC is ready
 0 = Clock switch may proceed when the oscillator selected by NOSC is ready; if this bit is clear at the time that NOSCR becomes '1', the switch will occur
- bit 6 **SOSCPWR:** Secondary Oscillator Power Mode Select bit
 1 = Secondary oscillator operating in High-power mode
 0 = Secondary oscillator operating in Low-power mode
- bit 5 **Unimplemented:** Read as '0'.
- bit 4 **ORDY:** Oscillator Ready bit (read-only)
 1 = OSCCON1 = OSCCON2; the current system clock is the clock specified by NOSC
 0 = A clock switch is in progress
- bit 3 **NOSCR:** New Oscillator is Ready bit (read-only)
 1 = A clock switch is in progress and the oscillator selected by NOSC indicates a "ready" condition
 0 = A clock switch is not in progress, or the NOSC-selected oscillator is not yet ready
- bit 2-0 **Unimplemented:** Read as '0'

PIC16(L)F18856/76

REGISTER 6-4: OSCSTAT: OSCILLATOR STATUS REGISTER 1

R-q/q	R-0/q	R-0/q	R-0/q	R-q/q	R-q/q	U-0	R-q/q
EXTOR	HFOR	MFOR	LFOR	SOR	ADOR	—	PLLR
bit 7						bit 0	

Legend:

R = Readable bit	W = Writable bit	U = Unimplemented bit, read as '0'
u = Bit is unchanged	x = Bit is unknown	-n/n = Value at POR and BOR/Value at all other Resets
'1' = Bit is set	'0' = Bit is cleared	

bit 7	EXTOR: EXTOSC (external) Oscillator Ready bit 1 = The oscillator is ready to be used 0 = The oscillator is not enabled, or is not yet ready to be used.
bit 6	HFOR: HFINTOSC Oscillator Ready bit 1 = The oscillator is ready to be used 0 = The oscillator is not enabled, or is not yet ready to be used.
bit 5	MFOR: MFINTOSC Oscillator Ready bit 1 = The oscillator is ready to be used 0 = The oscillator is not enabled, or is not yet ready to be used
bit 4	LFOR: LFINTOSC Oscillator Ready bit 1 = The oscillator is ready to be used 0 = The oscillator is not enabled, or is not yet ready to be used.
bit 3	SOR: Secondary (Timer1) Oscillator Ready bit 1 = The oscillator is ready to be used 0 = The oscillator is not enabled, or is not yet ready to be used.
bit 2	ADOR: CRC Oscillator Ready bit 1 = The oscillator is ready to be used 0 = The oscillator is not enabled, or is not yet ready to be used
bit 1	Unimplemented: Read as '0'
bit 0	PLL: PLL is Ready bit 1 = The PLL is ready to be used 0 = The PLL is not enabled, the required input source is not ready, or the PLL is not locked.

PIC16(L)F18856/76

REGISTER 6-5: OSCEN: OSCILLATOR MANUAL ENABLE REGISTER

R/W-0/0	R/W-0/0	R/W-0/0	R/W-0/0	R/W-0/0	R/W-0/0	U-0	U-0
EXTOEN	HFOEN	MFOEN	LFOEN	SOSCEN	ADOEN	—	—
bit 7						bit 0	

Legend:

R = Readable bit	W = Writable bit	U = Unimplemented bit, read as '0'
u = Bit is unchanged	x = Bit is unknown	-n/n = Value at POR and BOR/Value at all other Resets
'1' = Bit is set	'0' = Bit is cleared	

bit 7	EXTOEN: External Oscillator Manual Request Enable bit ⁽¹⁾ 1 = EXTOSC is explicitly enabled, operating as specified by FEXTOSC 0 = EXTOSC could be enabled by another module
bit 6	HFOEN: HFINTOSC Oscillator Manual Request Enable bit 1 = HFINTOSC is explicitly enabled, operating as specified by OSCFRQ 0 = HFINTOSC could be enabled by another module
bit 5	MFOEN: MFINTOSC Oscillator Manual Request Enable bit 1 = MFINTOSC is explicitly enabled 0 = MFINTOSC could be enabled by another module
bit 4	LFOEN: LFINTOSC (31 kHz) Oscillator Manual Request Enable bit 1 = LFINTOSC is explicitly enabled 0 = LFINTOSC could be enabled by another module
bit 3	SOSCEN: Secondary (Timer1) Oscillator Manual Request bit 1 = Secondary oscillator is explicitly enabled, operating as specified by SOSCPWR 0 = Secondary oscillator could be enabled by another module
bit 2	ADOEN: FRC Oscillator Manual Request Enable bit 1 = FRC is explicitly enabled 0 = FRC could be enabled by another module
bit 1-0	Unimplemented: Read as '0'

PIC16(L)F18856/76

REGISTER 6-6: OSCFRQ: HFINTOSC FREQUENCY SELECTION REGISTER

U-0	U-0	U-0	U-0	U-0	R/W-q/q	R/W-q/q	R/W-q/q
—	—	—	—	—	HFFRQ<2:0> ⁽¹⁾		
bit 7					bit 0		

Legend:

R = Readable bit	W = Writable bit	U = Unimplemented bit, read as '0'
u = Bit is unchanged	x = Bit is unknown	-n/n = Value at POR and BOR/Value at all other Resets
'1' = Bit is set	'0' = Bit is cleared	

bit 7-3 **Unimplemented:** Read as '0'

bit 2-0 **HFFRQ<2:0>:** HFINTOSC Frequency Selection bits

Nominal Freq (MHz) (NOSC = 110):

111 = Reserved

110 = 32

101 = 16

100 = 12

011 = 8

010 = 4

001 = 2

000 = 1

Note 1: When RSTOSC=110 (HFINTOSC 1 MHz), the HFFRQ bits will default to '010' upon Reset; when RSTOSC = 000 (HFINTOSC 32 MHz), the HFFRQ bits will default to '110' upon Reset.

PIC16(L)F18856/76

REGISTER 6-7: OSCTUNE: HFINTOSC TUNING REGISTER

U-0	U-0	R/W-1/1	R/W-0/0	R/W-0/0	R/W-0/0	R/W-0/0	R/W-0/0	
—	—	HFTUN<5:0>						
bit 7								bit 0

Legend:

R = Readable bit	W = Writable bit	U = Unimplemented bit, read as '0'
u = Bit is unchanged	x = Bit is unknown	-n/n = Value at POR and BOR/Value at all other Resets
'1' = Bit is set	'0' = Bit is cleared	

bit 7-6 **Unimplemented:** Read as '0'.

bit 5-0 **HFTUN<5:0>:** HFINTOSC Frequency Tuning bits

11 1111 = Maximum frequency

•

•

•

10 0001

10 0000 = Center frequency. Oscillator module is running at the calibrated frequency (default value).

01 1111

•

•

•

00 0000 = Minimum frequency.

PIC16(L)F18856/76

TABLE 6-3: SUMMARY OF REGISTERS ASSOCIATED WITH CLOCK SOURCES

Name	Bit 7	Bit 6	Bit 5	Bit 4	Bit 3	Bit 2	Bit 1	Bit 0	Register on Page
OSCCON1	—	NOSC<2:0>			NDIV<3:0>				122
OSCCON2	—	COSC<2:0>			CDIV<3:0>				122
OSCCON3	CWSHOLD	SOSCPWR	—	ORDY	NOSCR	—	—	—	123
OSCFRQ	—	—	—	—	—	HFFRQ<2:0>			126
OSCSTAT	EXTOR	HFOR	MFOR	LFOR	SOR	ADOR	—	PLLOR	124
OSCTUNE	—	—	HFTUN<5:0>						127
OSCCON	EXTOEN	HFOEN	MFOEN	LFOEN	SOSCEN	ADOEN	—	—	125

Legend: — = unimplemented location, read as '0'. Shaded cells are not used by clock sources.

TABLE 6-4: SUMMARY OF CONFIGURATION WORD WITH CLOCK SOURCES

Name	Bits	Bit -7	Bit -6	Bit 13/5	Bit 12/4	Bit 11/3	Bit 10/2	Bit 9/1	Bit 8/0	Register on Page
CONFIG1	13:8	—	—	FCMEN	—	CSWEN	—	—	CLKOUTEN	93
	7:0	—	RSTOSC<2:0>			—	FEXTOSC<2:0>			

Legend: — = unimplemented location, read as '0'. Shaded cells are not used by clock sources.

PIC16(L)F18856/76

7.0 INTERRUPTS

The interrupt feature allows certain events to preempt normal program flow. Firmware is used to determine the source of the interrupt and act accordingly. Some interrupts can be configured to wake the MCU from Sleep mode.

This chapter contains the following information for Interrupts:

- Operation
- Interrupt Latency
- Interrupts During Sleep
- INT Pin
- Automatic Context Saving

Many peripherals produce interrupts. Refer to the corresponding chapters for details.

A block diagram of the interrupt logic is shown in [Figure 7-1](#).

FIGURE 7-1: INTERRUPT LOGIC

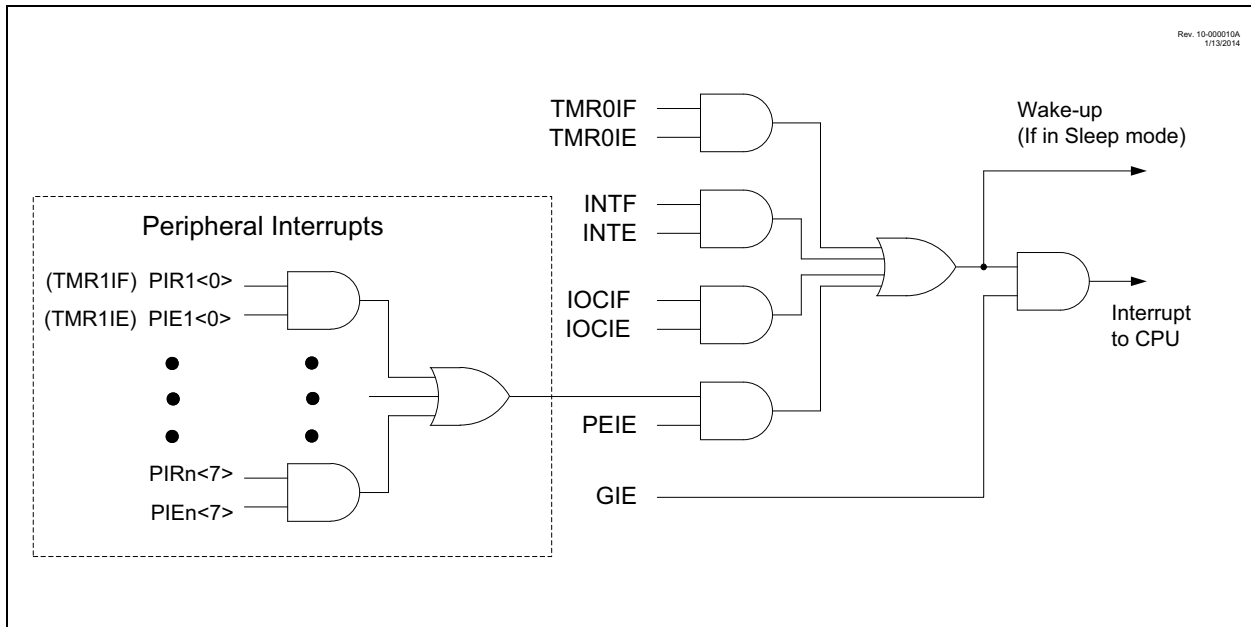

PIC16(L)F18856/76

7.1 Operation

Interrupts are disabled upon any device Reset. They are enabled by setting the following bits:

- GIE bit of the INTCON register
- Interrupt Enable bit(s) for the specific interrupt event(s)
- PEIE bit of the INTCON register (if the Interrupt Enable bit of the interrupt event is contained in the PEx registers)

The PIR1, PIR2, PIR3 and PIR4 registers record individual interrupts via interrupt flag bits. Interrupt flag bits will be set, regardless of the status of the GIE, PEIE and individual interrupt enable bits.

The following events happen when an interrupt event occurs while the GIE bit is set:

- Current prefetched instruction is flushed
- GIE bit is cleared
- Current Program Counter (PC) is pushed onto the stack
- Critical registers are automatically saved to the shadow registers (See “[Section 7.5 “Automatic Context Saving”](#)”)
- PC is loaded with the interrupt vector 0004h

The firmware within the Interrupt Service Routine (ISR) should determine the source of the interrupt by polling the interrupt flag bits. The interrupt flag bits must be cleared before exiting the ISR to avoid repeated interrupts. Because the GIE bit is cleared, any interrupt that occurs while executing the ISR will be recorded through its interrupt flag, but will not cause the processor to redirect to the interrupt vector.

The `RETFIE` instruction exits the ISR by popping the previous address from the stack, restoring the saved context from the shadow registers and setting the GIE bit.

For additional information on a specific interrupt's operation, refer to its peripheral chapter.

- | |
|--|
| <p>Note 1: Individual interrupt flag bits are set, regardless of the state of any other enable bits.</p> <p>2: All interrupts will be ignored while the GIE bit is cleared. Any interrupt occurring while the GIE bit is clear will be serviced when the GIE bit is set again.</p> |
|--|

7.2 Interrupt Latency

Interrupt latency is defined as the time from when the interrupt event occurs to the time code execution at the interrupt vector begins. The latency for synchronous interrupts is three or four instruction cycles. For asynchronous interrupts, the latency is three to five instruction cycles, depending on when the interrupt occurs. See [Figure 7-2](#) and [Figure 7-3](#) for more details.

PIC16(L)F18856/76

FIGURE 7-2: INTERRUPT LATENCY

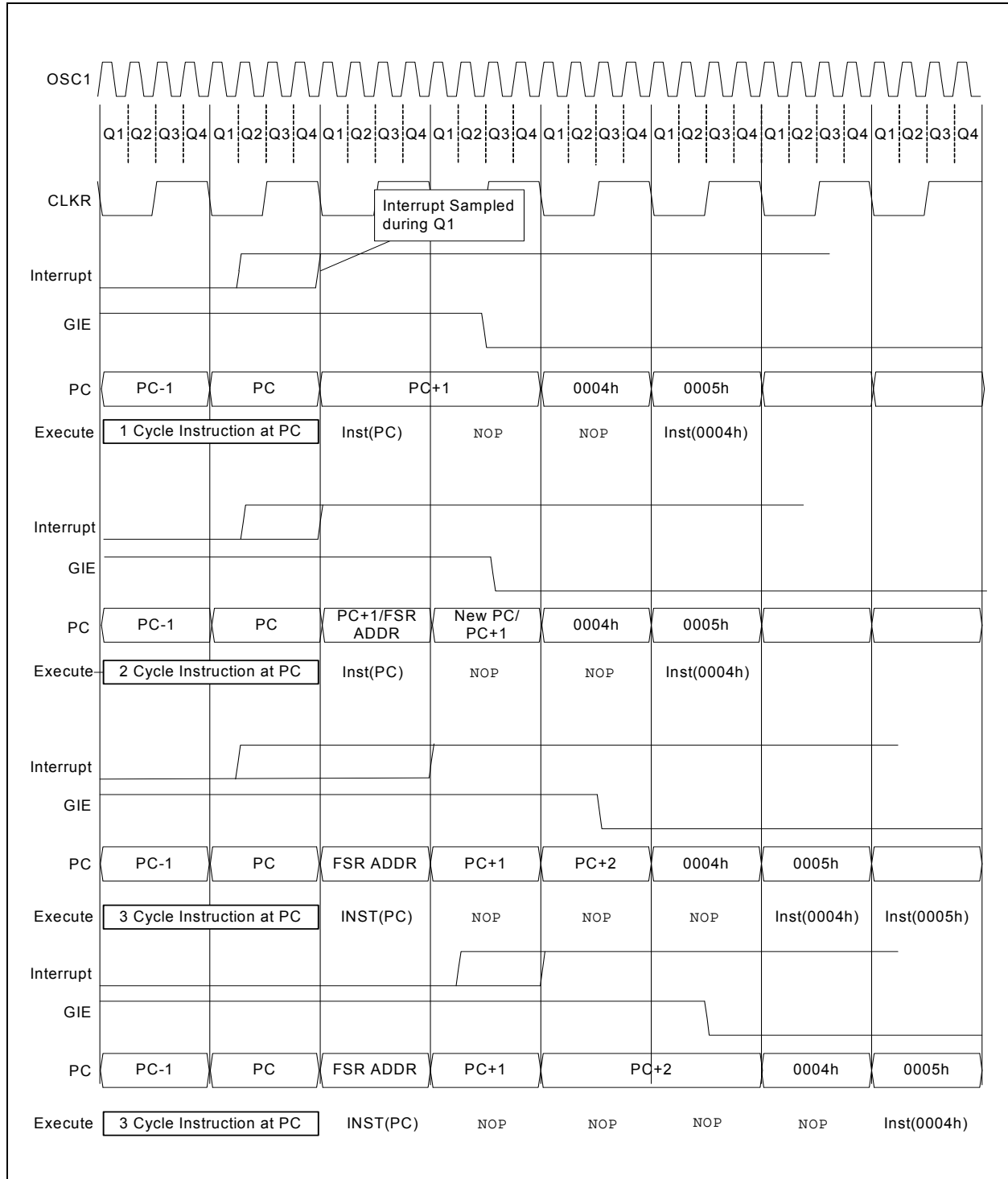

PIC16(L)F18856/76

FIGURE 7-3: INT PIN INTERRUPT TIMING

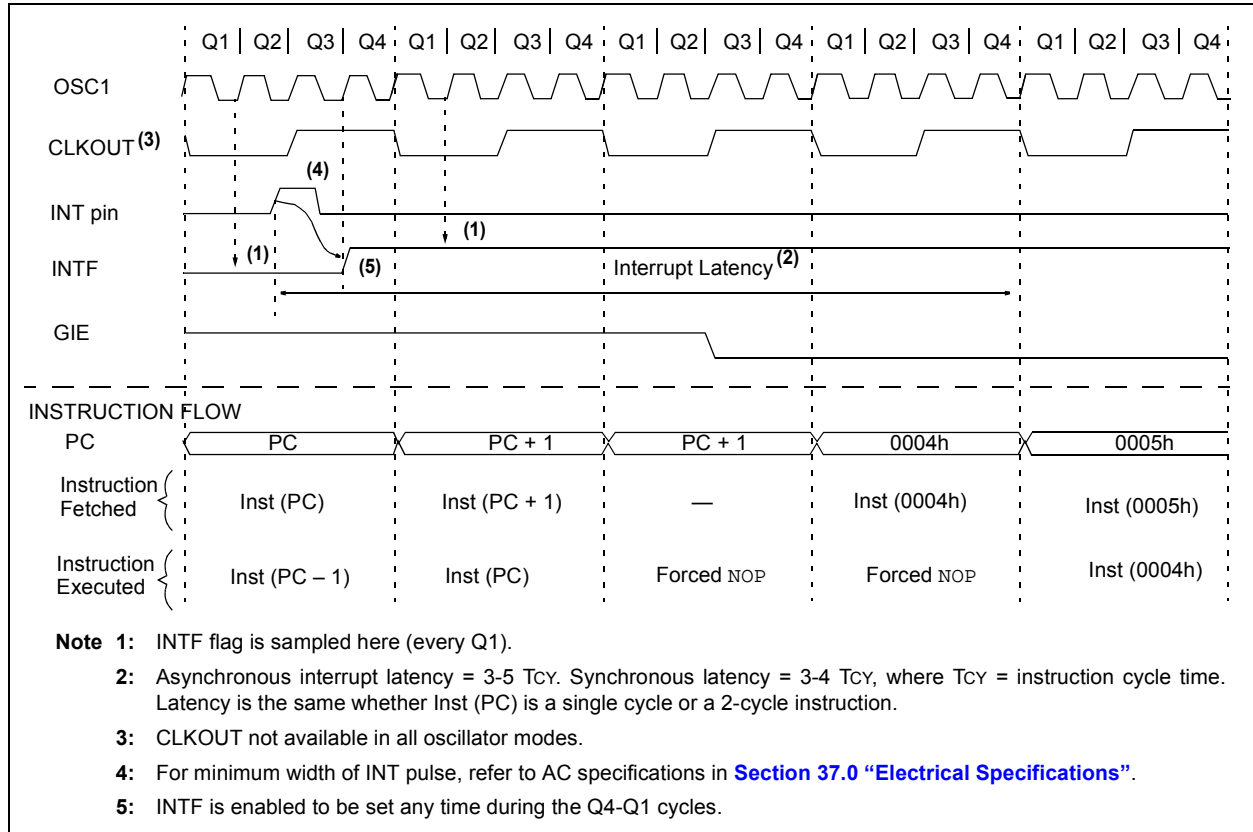

7.3 Interrupts During Sleep

Some interrupts can be used to wake from Sleep. To wake from Sleep, the peripheral must be able to operate without the system clock. The interrupt source must have the appropriate Interrupt Enable bit(s) set prior to entering Sleep.

On waking from Sleep, if the GIE bit is also set, the processor will branch to the interrupt vector. Otherwise, the processor will continue executing instructions after the `SLEEP` instruction. The instruction directly after the `SLEEP` instruction will always be executed before branching to the ISR. Refer to [Section 8.0 “Power-Saving Operation Modes”](#) for more details.

7.4 INT Pin

The INT pin can be used to generate an asynchronous edge-triggered interrupt. This interrupt is enabled by setting the INTE bit of the PIE0 register. The INTEDG bit of the INTCON register determines on which edge the interrupt will occur. When the INTEDG bit is set, the rising edge will cause the interrupt. When the INTEDG bit is clear, the falling edge will cause the interrupt. The INTF bit of the PIR0 register will be set when a valid edge appears on the INT pin. If the GIE and INTE bits are also set, the processor will redirect program execution to the interrupt vector.

7.5 Automatic Context Saving

Upon entering an interrupt, the return PC address is saved on the stack. Additionally, the following registers are automatically saved in the shadow registers:

- W register
- STATUS register (except for $\overline{\text{TO}}$ and $\overline{\text{PD}}$)
- BSR register
- FSR registers
- PCLATH register

Upon exiting the Interrupt Service Routine, these registers are automatically restored. Any modifications to these registers during the ISR will be lost. If modifications to any of these registers are desired, the corresponding shadow register should be modified and the value will be restored when exiting the ISR. The shadow registers are available in Bank 31 and are readable and writable. Depending on the user's application, other registers may also need to be saved.

PIC16(L)F18856/76

7.6 Register Definitions: Interrupt Control

REGISTER 7-1: INTCON: INTERRUPT CONTROL REGISTER

R/W-0/0	R/W-0/0	U-0	U-0	U-0	U-0	U-0	R/W-1/1
GIE	PEIE	—	—	—	—	—	INTEDG
bit 7							bit 0

Legend:

R = Readable bit

W = Writable bit

U = Unimplemented bit, read as '0'

u = Bit is unchanged

x = Bit is unknown

-n/n = Value at POR and BOR/Value at all other Resets

'1' = Bit is set

'0' = Bit is cleared

- bit 7 **GIE:** Global Interrupt Enable bit
1 = Enables all active interrupts
0 = Disables all interrupts
- bit 6 **PEIE:** Peripheral Interrupt Enable bit
1 = Enables all active peripheral interrupts
0 = Disables all peripheral interrupts
- bit 5-1 **Unimplemented:** Read as '0'
- bit 0 **INTEDG:** Interrupt Edge Select bit
1 = Interrupt on rising edge of INT pin
0 = Interrupt on falling edge of INT pin

Note: Interrupt flag bits are set when an interrupt condition occurs, regardless of the state of its corresponding enable bit or the Global Enable bit, GIE, of the INTCON register. User software should ensure the appropriate interrupt flag bits are clear prior to enabling an interrupt.

PIC16(L)F18856/76

REGISTER 7-2: PIE0: PERIPHERAL INTERRUPT ENABLE REGISTER 0

U-0	U-0	R/W-0/0	R/W-0/0	U-0	U-0	U-0	R/W-0/0
—	—	TMR0IE	IOCIE	—	—	—	INTE
bit 7							bit 0

Legend:

R = Readable bit	W = Writable bit	U = Unimplemented bit, read as '0'
u = Bit is unchanged	x = Bit is unknown	-n/n = Value at POR and BOR/Value at all other Resets
'1' = Bit is set	'0' = Bit is cleared	HS = Hardware set

- bit 7-6 **Unimplemented:** Read as '0'
- bit 5 **TMR0IE:** TMR0 Overflow Interrupt Enable bit
 1 = Enables the TMR0 interrupt
 0 = Disables the TMR0 interrupt
- bit 4 **IOCIE:** Interrupt-on-Change Interrupt Enable bit
 1 = Enables the IOC change interrupt
 0 = Disables the IOC change interrupt
- bit 3-1 **Unimplemented:** Read as '0'
- bit 0 **INTE:** INT External Interrupt Flag bit⁽¹⁾
 1 = Enables the INT external interrupt
 0 = Disables the INT external interrupt

Note 1: The External Interrupt GPIO pin is selected by INTPPS ([Register 13-1](#)).

Note: Bit PEIE of the INTCON register must be set to enable any peripheral interrupt controlled by PIE1-PIE8. Interrupt sources controlled by the PIE0 register do not require PEIE to be set in order to allow interrupt vectoring (when GIE is set).

PIC16(L)F18856/76

REGISTER 7-3: PIE1: PERIPHERAL INTERRUPT ENABLE REGISTER 1

R/W-0/0	R/W-0/0	U-0	U-0	U-0	U-0	R/W-0/0	R/W-0/0
OSFIE	CSWIE	—	—	—	—	ADTIE	ADIE
bit 7							bit 0

Legend:

R = Readable bit	W = Writable bit	U = Unimplemented bit, read as '0'
u = Bit is unchanged	x = Bit is unknown	-n/n = Value at POR and BOR/Value at all other Resets
'1' = Bit is set	'0' = Bit is cleared	

- bit 7 **OSFIE:** Oscillator Fail Interrupt Enable bit
 1 = Enables the Oscillator Fail Interrupt
 0 = Disables the Oscillator Fail Interrupt
- bit 6 **CSWIE:** Clock Switch Complete Interrupt Enable bit
 1 = The clock switch module interrupt is enabled
 0 = The clock switch module interrupt is disabled
- bit 5-2 **Unimplemented:** Read as '0'
- bit 1 **ADTIE:** Analog-to-Digital Converter (ADC) Threshold Compare Interrupt Enable bit
 1 = Enables the ADC threshold compare interrupt
 0 = Disables the ADC threshold compare interrupt
- bit 0 **ADIE:** Analog-to-Digital Converter (ADC) Interrupt Enable bit
 1 = Enables the ADC interrupt
 0 = Disables the ADC interrupt

Note 1: Bit PEIE of the INTCON register must be set to enable any peripheral interrupt controlled by registers PIE1-PIE8.

PIC16(L)F18856/76

REGISTER 7-4: PIE2: PERIPHERAL INTERRUPT ENABLE REGISTER 2

U-0	R/W-0/0	U-0	U-0	U-0	U-0	R/W-0/0	R/W-0/0
—	ZCDIE	—	—	—	—	C2IE	C1IE
bit 7						bit 0	

Legend:

R = Readable bit	W = Writable bit	U = Unimplemented bit, read as '0'
u = Bit is unchanged	x = Bit is unknown	-n/n = Value at POR and BOR/Value at all other Resets
'1' = Bit is set	'0' = Bit is cleared	

- bit 7 **Unimplemented:** Read as '0'
- bit 6 **ZCDIE:** Zero-Cross Detection (ZCD) Interrupt Enable bit
 - 1 = Enables the ZCD interrupt
 - 0 = Disables the ZCD interrupt
- bit 5-2 **Unimplemented:** Read as '0'
- bit 1 **C2IE:** Comparator C2 Interrupt Enable bit
 - 1 = Enables the Comparator C2 interrupt
 - 0 = Disables the Comparator C2 interrupt
- bit 0 **C1IE:** Comparator C1 Interrupt Enable bit
 - 1 = Enables the Comparator C1 interrupt
 - 0 = Disables the Comparator C1 interrupt

Note: Bit PEIE of the INTCON register must be set to enable any peripheral interrupt controlled by registers PIE1-PIE8.

PIC16(L)F18856/76

REGISTER 7-5: PIE3: PERIPHERAL INTERRUPT ENABLE REGISTER 3

U-0	U-0	R/W-0/0	R/W-0/0	R/W-0/0	R/W-0/0	R/W-0/0	R/W-0/0
—	—	RCIE	TXIE	BCL2IE	SSP2IE	BCL1IE	SSP1IE
bit 7							bit 0

Legend:

R = Readable bit W = Writable bit U = Unimplemented bit, read as '0'
 u = Bit is unchanged x = Bit is unknown -n/n = Value at POR and BOR/Value at all other Resets
 '1' = Bit is set '0' = Bit is cleared

- bit 7-6 **Unimplemented:** Read as '0'
- bit 5 **RCIE:** USART Receive Interrupt Enable bit
 1 = Enables the USART receive interrupt
 0 = Enables the USART receive interrupt
- bit 4 **TXIE:** USART Transmit Interrupt Enable bit
 1 = Enables the USART transmit interrupt
 0 = Disables the USART transmit interrupt
- bit 3 **BCL2IE:** MSSP2 Bus Collision Interrupt Enable bit
 1 = MSSP bus Collision interrupt enabled
 0 = MSSP bus Collision interrupt disabled
- bit 2 **SSP2IE:** Synchronous Serial Port (MSSP2) Interrupt Enable bit
 1 = MSSP bus collision Interrupt
 0 = Disables the MSSP Interrupt
- bit 1 **BCL1IE:** MSSP1 Bus Collision Interrupt Enable bit
 1 = MSSP bus collision interrupt enabled
 0 = MSSP bus collision interrupt disabled
- bit 0 **SSP1IE:** Synchronous Serial Port (MSSP1) Interrupt Enable bit
 1 = Enables the MSSP interrupt
 0 = Disables the MSSP interrupt

Note: Bit PEIE of the INTCON register must be set to enable any peripheral interrupt controlled by PIE1-PIE8.

PIC16(L)F18856/76

REGISTER 7-6: PIE4: PERIPHERAL INTERRUPT ENABLE REGISTER 4

U-0	U-0	R/W-0/0	R/W-0/0	R/W-0/0	R/W-0/0	R/W-0/0	R/W-0/0
—	—	TMR6IE	TMR5IE	TMR4IE	TMR3IE	TMR2IE	TMR1IE
bit 7							bit 0

Legend:

R = Readable bit	W = Writable bit	U = Unimplemented bit, read as '0'
u = Bit is unchanged	x = Bit is unknown	-n/n = Value at POR and BOR/Value at all other Resets
'1' = Bit is set	'0' = Bit is cleared	HS = Hardware set

- bit 7-6 **Unimplemented:** Read as '0'
- bit 5 **TMR6IE:** TMR6 to PR6 Match Interrupt Enable bit
 1 = Enables the Timer6 to PR6 match interrupt
 0 = Disables the Timer6 to PR6 match interrupt
- bit 4 **TMR5IE:** Timer5 Overflow Interrupt Enable bit
 1 = Enables the Timer5 overflow interrupt
 0 = Disables the Timer5 overflow interrupt
- bit 3 **TMR4IE:** TMR4 to PR4 Match Interrupt Enable bit
 1 = Enables the Timer4 to PR4 match interrupt
 0 = Disables the Timer4 to PR4 match interrupt
- bit 2 **TMR3IE:** TMR3 Overflow Interrupt Enable bit
 1 = Enables the Timer3 overflow interrupt
 0 = Enables the Timer3 overflow interrupt
- bit 1 **TMR2IE:** TMR2 to PR2 Match Interrupt Enable bit
 1 = Enables the Timer2 to PR2 match interrupt
 0 = Disables the Timer2 to PR2 match interrupt
- bit 0 **TMR1IE:** Timer1 Overflow Interrupt Enable bit
 1 = Enables the Timer1 overflow interrupt
 0 = Enables the Timer1 overflow interrupt

Note: Bit PEIE of the INTCON register must be set to enable any peripheral interrupt controlled by registers PIE1-PIE8.

PIC16(L)F18856/76

REGISTER 7-7: PIE5: PERIPHERAL INTERRUPT ENABLE REGISTER 5

R/W-0/0	R/W-0/0	R/W-0/0	R/W-0/0	U-0	R/W-0/0	R/W-0/0	R/W-0/0
CLC4IE	CLC3IE	CLC2IE	CLC1IE	—	TMR5GIE	TMR3GIE	TMR1GIE
bit 7							bit 0

Legend:

R = Readable bit	W = Writable bit	U = Unimplemented bit, read as '0'
u = Bit is unchanged	x = Bit is unknown	-n/n = Value at POR and BOR/Value at all other Resets
'1' = Bit is set	'0' = Bit is cleared	HS = Hardware set

bit 7	CLC4IE: CLC4 Interrupt Enable bit 1 = CLC4 interrupt enabled 0 = CLC4 interrupt disabled
bit 6	CLC3IE: CLC3 Interrupt Enable bit 1 = CLC3 interrupt enabled 0 = CLC3 interrupt disabled
bit 5	CLC2IE: CLC2 Interrupt Enable bit 1 = CLC2 interrupt enabled 0 = CLC2 interrupt disabled
bit 4	CLC1IE: CLC1 Interrupt Enable bit 1 = CLC1 interrupt enabled 0 = CLC1 interrupt disabled
bit 3	Unimplemented: Read as '0'
bit 2	TMR5GIE: Timer5 Gate Interrupt Enable bit 1 = Enables the Timer5 gate acquisition interrupt 0 = Disables the Timer5 gate acquisition interrupt
bit 1	TMR3GIE: Timer3 Gate Interrupt Enable bit 1 = Enables the Timer3 gate acquisition interrupt 0 = Disables the Timer3 gate acquisition interrupt
bit 0	TMR1GIE: Timer1 Gate Interrupt Enable bit 1 = Enables the Timer1 gate acquisition interrupt 0 = Disables the Timer1 gate acquisition interrupt

Note: Bit PEIE of the INTCON register must be set to enable any peripheral interrupt controlled by registers PIE1-PIE8.

PIC16(L)F18856/76

REGISTER 7-8: PIE6: PERIPHERAL INTERRUPT ENABLE REGISTER 6

U-0	U-0	U-0	R/W-0/0	R/W-0/0	R/W-0/0	R/W-0/0	R/W-0/0
—	—	—	CCP5IE	CCP4IE	CCP3IE	CCP2IE	CCP1IE
bit 7							bit 0

Legend:

R = Readable bit

W = Writable bit

U = Unimplemented bit, read as '0'

u = Bit is unchanged

x = Bit is unknown

-n/n = Value at POR and BOR/Value at all other Resets

'1' = Bit is set

'0' = Bit is cleared

HS = Hardware set

- bit 7-5 **Unimplemented:** Read as '0'.
- bit 4 **CCP5IE:** CCP5 Interrupt Enable bit
 1 = CCP5 interrupt is enabled
 0 = CCP5 interrupt is disabled
- bit 3 **CCP4IE:** CCP4 Interrupt Enable bit
 1 = CCP4 interrupt is enabled
 0 = CCP4 interrupt is disabled
- bit 2 **CCP3IE:** CCP3 Interrupt Enable bit
 1 = CCP3 interrupt is enabled
 0 = CCP3 interrupt is disabled
- bit 1 **CCP2IE:** CCP2 Interrupt Enable bit
 1 = CCP2 interrupt is enabled
 0 = CCP2 interrupt is disabled
- bit 0 **CCP1IE:** CCP1 Interrupt Enable bit
 1 = CCP1 interrupt is enabled
 0 = CCP1 interrupt is disabled

Note: Bit PEIE of the INTCON register must be set to enable any peripheral interrupt controlled by registers PIE1-PIE8.

PIC16(L)F18856/76

REGISTER 7-9: PIE7: PERIPHERAL INTERRUPT ENABLE REGISTER 7

R/W-0/0	R/W-0/0	R/W-0/0	R/W-0/0	U-0	R/W-0/0	R/W-0/0	R/W-0/0
SCANIE	CRCIE	NVMIE	NCO1IE	—	CWG3IE	CWG2IE	CWG1IE
bit 7							bit 0

Legend:

R = Readable bit	W = Writable bit	U = Unimplemented bit, read as '0'
u = Bit is unchanged	x = Bit is unknown	-n/n = Value at POR and BOR/Value at all other Resets
'1' = Bit is set	'0' = Bit is cleared	HS = Hardware set

- bit 7 **SCANIE:** Scanner Interrupt Enable bit
1 = Enables the scanner interrupt
0 = Disables the scanner interrupt
- bit 6 **CRCIE:** CRC Interrupt Enable bit
1 = Enables the CRC interrupt
0 = Disables the CRC interrupt
- bit 5 **NVMIE:** NVM Interrupt Enable bit
1 = NVM task complete interrupt enabled
0 = NVM interrupt not enabled
- bit 4 **NCO1IE:** NCO Interrupt Enable bit
1 = NCO rollover interrupt enabled
0 = NCO rollover interrupt disabled
- bit 3 **Unimplemented:** Read as '0'.
- bit 2 **CWG3IE:** Complementary Waveform Generator (CWG) 3 Interrupt Enable bit
1 = CWG3 interrupt enabled
0 = CWG3 interrupt disabled
- bit 1 **CWG2IE:** Complementary Waveform Generator (CWG) 2 Interrupt Enable bit
1 = CWG2 interrupt is enabled
0 = CWG2 interrupt disabled
- bit 0 **CWG1IE:** Complementary Waveform Generator (CWG) 1 Interrupt Enable bit
1 = CWG1 interrupt is enabled
0 = CWG1 interrupt disabled

Note: Bit PEIE of the INTCON register must be set to enable any peripheral interrupt controlled by registers PIE1-PIE8.

PIC16(L)F18856/76

REGISTER 7-10: PIE8: PERIPHERAL INTERRUPT ENABLE REGISTER 8

U-0	U-0	R/W-0/0	R/W-0/0	R/W-0/0	R/W-0/0	R/W-0/0	R/W-0/0
—	—	SMT2PWAIE	SMT2PRAIE	SMT2IE	SMT1PWAIE	SMT1PRAIE	SMT1IE
bit 7							bit 0

Legend:

R = Readable bit	W = Writable bit	U = Unimplemented bit, read as '0'
u = Bit is unchanged	x = Bit is unknown	-n/n = Value at POR and BOR/Value at all other Resets
'1' = Bit is set	'0' = Bit is cleared	HS = Hardware set

- bit 7-6 **Unimplemented:** Read as '0'.
- bit 6 **SMT2PWAIE:** SMT2 Pulse-Width Acquisition Interrupt Enable bit
1 = Enables the SMT acquisition interrupt
0 = Disables the SMT acquisition interrupt
- bit 5 **SMT2PRAIE:** SMT2 Period Acquisition Interrupt Enable bit
1 = Enables the SMT acquisition interrupt
0 = Disables the SMT acquisition interrupt
- bit 4 **SMT2IE:** SMT2 Overflow Interrupt Enable bit
1 = Enables the SMT overflow interrupt
0 = Disables the SMT overflow interrupt
- bit 2 **SMT1PWAIE:** SMT1 Pulse-Width Acquisition Interrupt Enable bit
1 = Enables the SMT acquisition interrupt
0 = Disables the SMT acquisition interrupt
- bit 1 **SMT1PRAIE:** SMT1 Period Acquisition Interrupt Enable bit
1 = Enables the SMT acquisition interrupt
0 = Disables the SMT acquisition interrupt
- bit 0 **SMT1IE:** SMT1 Overflow Interrupt Enable bit
1 = Enables the SMT overflow interrupt
0 = Disables the SMT overflow interrupt

Note: Bit PEIE of the INTCON register must be set to enable any peripheral interrupt controlled by registers PIE1-PIE8.

PIC16(L)F18856/76

REGISTER 7-11: PIR0: PERIPHERAL INTERRUPT STATUS REGISTER 0

U-0	U-0	R/W/HS-0/0	R-0	U-0	U-0	U-0	R/W/HS-0/0
—	—	TMR0IF	IOCIF	—	—	—	INTF ⁽¹⁾
bit 7							bit 0

Legend:

R = Readable bit	W = Writable bit	U = Unimplemented bit, read as '0'
u = Bit is unchanged	x = Bit is unknown	-n/n = Value at POR and BOR/Value at all other Resets
'1' = Bit is set	'0' = Bit is cleared	HS= Hardware Set

bit 7-6 **Unimplemented:** Read as '0'

bit 5 **TMR0IF:** TMR0 Overflow Interrupt Flag bit

- 1 = TMR0 register has overflowed (must be cleared in software)
- 0 = TMR0 register did not overflow

bit 4 **IOCIF:** Interrupt-on-Change Interrupt Flag bit (read-only)⁽²⁾

- 1 = One or more of the IOCAF-IOCEF register bits are currently set, indicating an enabled edge was detected by the IOC module.
- 0 = None of the IOCAF-IOCEF register bits are currently set

bit 3-1 **Unimplemented:** Read as '0'

bit 0 **INTF:** INT External Interrupt Flag bit⁽¹⁾

- 1 = The INT external interrupt occurred (must be cleared in software)
- 0 = The INT external interrupt did not occur

Note 1: The External Interrupt GPIO pin is selected by INTPPS ([Register 13-1](#)).

Note 2: The IOCIF bits are the logical OR of all the IOCAF-IOCEF flags. Therefore, to clear the IOCIF flag, application firmware should clear all of the lower level IOCAF-IOCEF register bits.

Note: Interrupt flag bits are set when an interrupt condition occurs, regardless of the state of its corresponding enable bit or the Global Enable bit, GIE, of the INTCON register. User software should ensure the appropriate interrupt flag bits are clear prior to enabling an interrupt.

PIC16(L)F18856/76

REGISTER 7-12: PIR1: PERIPHERAL INTERRUPT REQUEST REGISTER 1

R/W/HS-0/0	R/W/HS-0/0	U-0	U-0	U-0	U-0	R/W/HS-0/0	R/W/HS-0/0
OSFIF	CSWIF	—	—	—	—	ADTIF	ADIF
bit 7						bit 0	

Legend:

R = Readable bit	W = Writable bit	U = Unimplemented bit, read as '0'
u = Bit is unchanged	x = Bit is unknown	-n/n = Value at POR and BOR/Value at all other Resets
'1' = Bit is set	'0' = Bit is cleared	HS = Hardware set

- bit 7 **OSFIF:** Oscillator Fail-Safe Interrupt Flag bit
 1 = Oscillator fail-safe interrupt has occurred (must be cleared in software)
 0 = No oscillator fail-safe interrupt
- bit 6 **CSWIF:** Clock Switch Complete Interrupt Flag bit
 1 = The clock switch module indicates an interrupt condition (must be cleared in software)
 0 = The clock switch does not indicate an interrupt condition
- bit 5-2 **Unimplemented:** Read as '0'
- bit 1 **ADTIF:** Analog-to-Digital Converter (ADC) Threshold Compare Interrupt Flag bit
 1 = An A/D measurement was beyond the configured threshold (must be cleared in software)
 0 = A/D measurements have been within the configured threshold
- bit 0 **ADIF:** Analog-to-Digital Converter (ADC) Interrupt Flag bit
 1 = An A/D conversion or complex operation has completed (must be cleared in software)
 0 = An A/D conversion or complex operation is not complete

Note: Interrupt flag bits are set when an interrupt condition occurs, regardless of the state of its corresponding enable bit or the Global Enable bit, GIE, of the INTCON register. User software should ensure the appropriate interrupt flag bits are clear prior to enabling an interrupt.

PIC16(L)F18856/76

REGISTER 7-13: PIR2: PERIPHERAL INTERRUPT REQUEST REGISTER 2

U-0	R/W/HS-0/0	U-0	U-0	U-0	U-0	R/W/HS-0/0	R/W/HS-0/0
—	ZCDIF	—	—	—	—	C2IF	C1IF
bit 7						bit 0	

Legend:
 R = Readable bit W = Writable bit U = Unimplemented bit, read as '0'
 u = Bit is unchanged x = Bit is unknown -n/n = Value at POR and BOR/Value at all other Resets
 '1' = Bit is set '0' = Bit is cleared HS = Hardware set

- bit 7 **Unimplemented:** Read as '0'
- bit 6 **ZCDIF:** Zero-Cross Detect (ZCD) Interrupt Flag bit
 1 = An enabled rising and/or falling ZCD event has been detected (must be cleared in software)
 0 = No ZCD event has occurred
- bit 5-2 **Unimplemented:** Read as '0'
- bit 1 **C2IF:** Comparator C2 Interrupt Flag bit
 1 = Comparator 2 interrupt asserted (must be cleared in software)
 0 = Comparator 2 interrupt not asserted
- bit 0 **C1IF:** Comparator C1 Interrupt Flag bit
 1 = Comparator 1 interrupt asserted (must be cleared in software)
 0 = Comparator 1 interrupt not asserted

Note: Interrupt flag bits are set when an interrupt condition occurs, regardless of the state of its corresponding enable bit or the Global Enable bit, GIE, of the INTCON register. User software should ensure the appropriate interrupt flag bits are clear prior to enabling an interrupt.

PIC16(L)F18856/76

REGISTER 7-14: PIR3: PERIPHERAL INTERRUPT REQUEST REGISTER 3

U-0	U-0	R-0	R-0	R/W/HS-0/0	R/W/HS-0/0	R/W/HS-0/0	R/W/HS-0/0
—	—	RCIF	TXIF	BCL2IF	SSP2IF	BCL1IF	SSP1IF
bit 7							bit 0

Legend:

R = Readable bit	W = Writable bit	U = Unimplemented bit, read as '0'
u = Bit is unchanged	x = Bit is unknown	-n/n = Value at POR and BOR/Value at all other Resets
'1' = Bit is set	'0' = Bit is cleared	HS = Hardware clearable

- bit 7-6 **Unimplemented:** Read as '0'
- bit 5 **RCIF:** EUSART Receive Interrupt Flag (read-only) bit ⁽¹⁾
 1 = The EUSART receive buffer is not empty (contains at least one byte)
 0 = The EUSART receive buffer is empty
- bit 4 **TXIF:** EUSART Transmit Interrupt Flag (read-only) bit⁽²⁾
 1 = The EUSART transmit buffer contains at least one unoccupied space
 0 = The EUSART transmit buffer is currently full. The application firmware should not write to TXREG again, until more room becomes available in the transmit buffer.
- bit 3 **BCL2IF:** MSSP2 Bus Collision Interrupt Flag bit
 1 = A bus collision was detected (must be cleared in software)
 0 = No bus collision was detected
- bit 2 **SSP2IF:** Synchronous Serial Port (MSSP2) Interrupt Flag bit
 1 = The Transmission/Reception/Bus Condition is complete (must be cleared in software)
 0 = Waiting for the Transmission/Reception/Bus Condition in progress
- bit 1 **BCL1IF:** MSSP1 Bus Collision Interrupt Flag bit
 1 = A bus collision was detected (must be cleared in software)
 0 = No bus collision was detected
- bit 0 **SSP1IF:** Synchronous Serial Port (MSSP1) Interrupt Flag bit
 1 = The Transmission/Reception/Bus Condition is complete (must be cleared in software)
 0 = Waiting for the Transmission/Reception/Bus Condition in progress

- Note 1:** The RCIF flag is a read-only bit. To clear the RCIF flag, the firmware must read from RCREG enough times to remove all bytes from the receive buffer.
- 2:** The TXIF flag is a read-only bit, indicating if there is room in the transmit buffer. To clear the TXIF flag, the firmware must write enough data to TXREG to completely fill all available bytes in the buffer. The TXIF flag does not indicate transmit completion (use TRMT for this purpose instead).

Note: Interrupt flag bits are set when an interrupt condition occurs, regardless of the state of its corresponding enable bit or the Global Enable bit, GIE, of the INTCON register. User software should ensure the appropriate interrupt flag bits are clear prior to enabling an interrupt.

PIC16(L)F18856/76

REGISTER 7-15: PIR4: PERIPHERAL INTERRUPT REQUEST REGISTER 4

U-0	U-0	R/W/HS-0/0	R/W/HS-0/0	R/W/HS-0/0	R/W/HS-0/0	R/W/HS-0/0	R/W/HS-0/0
—	—	TMR6IF	TMR5IF	TMR4IF	TMR3IF	TMR2IF	TMR1IF
bit 7							bit 0

Legend:		
R = Readable bit	W = Writable bit	U = Unimplemented bit, read as '0'
u = Bit is unchanged	x = Bit is unknown	-n/n = Value at POR and BOR/Value at all other Resets
'1' = Bit is set	'0' = Bit is cleared	HS = Hardware set

- bit 7-6 **Unimplemented:** Read as '0'
- bit 5 **TRM6IF:** Timer6 Interrupt Flag bit
 1 = The TMR6 postscaler overflowed, or in 1:1 mode, a TMR6 to PR6 match occurred (must be cleared in software)
 0 = No TMR6 event has occurred
- bit 4 **TRM5IF:** Timer5 Overflow Interrupt Flag bit
 1 = TMR5 overflow occurred (must be cleared in software)
 0 = No TMR5 overflow occurred
- bit 3 **TRM4IF:** Timer4 Interrupt Flag bit
 1 = The TMR4 postscaler overflowed, or in 1:1 mode, a TMR4 to PR4 match occurred (must be cleared in software)
 0 = No TMR4 event has occurred
- bit 2 **TRM3IF:** Timer3 Overflow Interrupt Flag bit
 1 = TMR3 overflow occurred (must be cleared in software)
 0 = No TMR3 overflow occurred
- bit 1 **TRM2IF:** Timer2 Interrupt Flag bit
 1 = The TMR2 postscaler overflowed, or in 1:1 mode, a TMR2 to PR2 match occurred (must be cleared in software)
 0 = No TMR2 event has occurred
- bit 0 **TRM1IF:** Timer1 Overflow Interrupt Flag bit
 1 = TMR1 overflow occurred (must be cleared in software)
 0 = No TMR1 overflow occurred

PIC16(L)F18856/76

REGISTER 7-16: PIR5: PERIPHERAL INTERRUPT REQUEST REGISTER 5

R/W/HS-0/0	R/W/HS-0/0	R/W/HS-0/0	R/W/HS-0/0	U-0	R/W/HS-0/0	R/W/HS-0/0	R/W/HS-0/0
CLC4IF	CLC3IF	CLC2IF	CLC1IF	—	TMR5GIF	TMR3GIF	TMR1GIF
bit 7							bit 0

Legend:

R = Readable bit	W = Writable bit	U = Unimplemented bit, read as '0'
u = Bit is unchanged	x = Bit is unknown	-n/n = Value at POR and BOR/Value at all other Resets
'1' = Bit is set	'0' = Bit is cleared	HS = Hardware set

- bit 7 **CLC4IF:** CLC4 Interrupt Flag bit
 1 = A CLC4OUT interrupt condition has occurred (must be cleared in software)
 0 = No CLC4 interrupt event has occurred
- bit 6 **CLC3IF:** CLC3 Interrupt Flag bit
 1 = A CLC4OUT interrupt condition has occurred (must be cleared in software)
 0 = No CLC4 interrupt event has occurred
- bit 5 **CLC2IF:** CLC2 Interrupt Flag bit
 1 = A CLC4OUT interrupt condition has occurred (must be cleared in software)
 0 = No CLC4 interrupt event has occurred
- bit 4 **CLC1IF:** CLC1 Interrupt Flag bit
 1 = A CLC4OUT interrupt condition has occurred (must be cleared in software)
 0 = No CLC4 interrupt event has occurred
- bit 3 **Unimplemented:** Read as '0'
- bit 2 **TMR5GIF:** Timer5 Gate Interrupt Flag bit
 1 = The Timer5 Gate has gone inactive (the gate is closed)
 0 = The Timer5 Gate has not gone inactive
- bit 1 **TMR3GIF:** Timer3 Gate Interrupt Flag bit
 1 = The Timer5 Gate has gone inactive (the gate is closed)
 0 = The Timer5 Gate has not gone inactive
- bit 0 **TMR1GIF:** Timer1 Gate Interrupt Flag bit
 1 = The Timer1 Gate has gone inactive (the gate is closed)
 0 = The Timer1 Gate has not gone inactive

Note: Interrupt flag bits are set when an interrupt condition occurs, regardless of the state of its corresponding enable bit or the Global Enable bit, GIE, of the INTCON register. User software should ensure the appropriate interrupt flag bits are clear prior to enabling an interrupt.

PIC16(L)F18856/76

REGISTER 7-17: PIR6: PERIPHERAL INTERRUPT REQUEST REGISTER 6

U-0	U-0	U-0	R/W/HS-0/0	R/W/HS-0/0	R/W/HS-0/0	R/W/HS-0/0	R/W/HS-0/0	
—	—	—	CCP5IF	CCP4IF	CCP3IF	CCP2IF	CCP1IF	
bit 7								bit 0

Legend:

R = Readable bit	W = Writable bit	U = Unimplemented bit, read as '0'
u = Bit is unchanged	x = Bit is unknown	-n/n = Value at POR and BOR/Value at all other Resets
'1' = Bit is set	'0' = Bit is cleared	HS = Hardware set

bit 7-5 **Unimplemented:** Read as '0'

bit 4 **CCP5IF:** CCP5 Interrupt Flag bit

Value	CCPM Mode		
	Capture	Compare	PWM
1	Capture occurred (must be cleared in software)	Compare match occurred (must be cleared in software)	Output trailing edge occurred (must be cleared in software)
0	Capture did not occur	Compare match did not occur	Output trailing edge did not occur

bit 3 **CCP4IF:** CCP4 Interrupt Flag bit

Value	CCPM Mode		
	Capture	Compare	PWM
1	Capture occurred (must be cleared in software)	Compare match occurred (must be cleared in software)	Output trailing edge occurred (must be cleared in software)
0	Capture did not occur	Compare match did not occur	Output trailing edge did not occur

bit 2 **CCP3IF:** CCP3 Interrupt Flag bit

Value	CCPM Mode		
	Capture	Compare	PWM
1	Capture occurred (must be cleared in software)	Compare match occurred (must be cleared in software)	Output trailing edge occurred (must be cleared in software)
0	Capture did not occur	Compare match did not occur	Output trailing edge did not occur

bit 1 **CCP2IF:** CCP2 Interrupt Flag bit

Value	CCPM Mode		
	Capture	Compare	PWM
1	Capture occurred (must be cleared in software)	Compare match occurred (must be cleared in software)	Output trailing edge occurred (must be cleared in software)
0	Capture did not occur	Compare match did not occur	Output trailing edge did not occur

bit 0 **CCP1IF:** CCP1 Interrupt Flag bit

Value	CCPM Mode		
	Capture	Compare	PWM
1	Capture occurred (must be cleared in software)	Compare match occurred (must be cleared in software)	Output trailing edge occurred (must be cleared in software)
0	Capture did not occur	Compare match did not occur	Output trailing edge did not occur

Note: Interrupt flag bits are set when an interrupt condition occurs, regardless of the state of its corresponding enable bit or the Global Enable bit, GIE, of the INTCON register. User software should ensure the appropriate interrupt flag bits are clear prior to enabling an interrupt.

PIC16(L)F18856/76

REGISTER 7-18: PIR6: PERIPHERAL INTERRUPT REQUEST REGISTER 6

U-0	U-0	U-0	R/W/HS-0/0	R/W/HS-0/0	R/W/HS-0/0	R/W/HS-0/0	R/W/HS-0/0	
—	—	—	CCP5IF	CCP4IF	CCP3IF	CCP2IF	CCP1IF	
bit 7								bit 0

Legend:

R = Readable bit	W = Writable bit	U = Unimplemented bit, read as '0'
u = Bit is unchanged	x = Bit is unknown	-n/n = Value at POR and BOR/Value at all other Resets
'1' = Bit is set	'0' = Bit is cleared	HS = Hardware set

bit 7-5 **Unimplemented:** Read as '0'

bit 4 **CCP5IF:** CCP5 Interrupt Flag bit

CCP5IF = 1:

Capture mode: Capture occurred (must be cleared in software)

Compare mode: Compare match occurred (must be cleared in software)

PWM mode: Output trailing edge occurred (must be cleared in software)

CCP5IF = 0:

Capture mode: Capture did not occur

Compare mode: Compare match did not occur

PWM mode: Output trailing edge did not occur

bit 3 **CCP4IF:** CCP4 Interrupt Flag bit

CCP4IF = 1:

Capture mode: Capture occurred (must be cleared in software)

Compare mode: Compare match occurred (must be cleared in software)

PWM mode: Output trailing edge occurred (must be cleared in software)

CCP4IF = 0:

Capture mode: Capture did not occur

Compare mode: Compare match did not occur

PWM mode: Output trailing edge did not occur

bit 2 **CCP3IF:** CCP3 Interrupt Flag bit

CCP3IF = 1:

Capture mode: Capture occurred (must be cleared in software)

Compare mode: Compare match occurred (must be cleared in software)

PWM mode: Output trailing edge occurred (must be cleared in software)

CCP3IF = 0:

Capture mode: Capture did not occur

Compare mode: Compare match did not occur

PWM mode: Output trailing edge did not occur

bit 1 **CCP2IF:** CCP2 Interrupt Flag bit

CCP2IF = 1:

Capture mode: Capture occurred (must be cleared in software)

Compare mode: Compare match occurred (must be cleared in software)

PWM mode: Output trailing edge occurred (must be cleared in software)

CCP2IF = 0:

Capture mode: Capture did not occur

Compare mode: Compare match did not occur

PWM mode: Output trailing edge did not occur

bit 0 **CCP1IF:** CCP1 Interrupt Flag bit

CCP1IF = 1:

Capture mode: Capture occurred (must be cleared in software)

Compare mode: Compare match occurred (must be cleared in software)

PWM mode: Output trailing edge occurred (must be cleared in software)

CCP1IF = 0:

Capture mode: Capture did not occur

Compare mode: Compare match did not occur

PWM mode: Output trailing edge did not occur

PIC16(L)F18856/76

REGISTER 7-19: PIR7: PERIPHERAL INTERRUPT REQUEST REGISTER 7

R/W/HS-0/0	R/W/HS-0/0	R/W/HS-0/0	R/W/HS-0/0	U-0	R/W/HS-0/0	R/W/HS-0/0	R/W/HS-0/0
SCANIF	CRCIF	NVMIF	NCO1IF	—	CWG3IF	CWG2IF	CWG1IF
bit 7							bit 0

Legend:

R = Readable bit	W = Writable bit	U = Unimplemented bit, read as '0'
u = Bit is unchanged	x = Bit is unknown	-n/n = Value at POR and BOR/Value at all other Resets
'1' = Bit is set	'0' = Bit is cleared	HS = Hardware set

- bit 7 **SCANIF:** Program Memory Scanner Interrupt Flag bit
 1 = The operation has completed (a SCANGO 1 to 0 transition has occurred)
 0 = No operation is pending or the operation is still in progress
- bit 6 **CRCIF:** CRC Interrupt Flag bit
 1 = The operation has completed (a BUSY 1 to 0 transition has occurred)
 0 = No operation is pending or the operation is still in progress
- bit 5 **NVMIF:** Non-Volatile Memory (NVM) Interrupt Flag bit
 1 = The requested NVM operation has completed
 0 = NVM interrupt not asserted
- bit 4 **NCO1IF:** Numerically Controlled Oscillator (NCO) Interrupt Flag bit
 1 = The NCO has rolled over
 0 = No CLC4 interrupt event has occurred
- bit 3 **Unimplemented:** Read as '0'
- bit 2 **CWG3IF:** CWG3 Interrupt Flag bit
 1 = CWG3 has gone into shutdown
 0 = CWG3 is operating normally, or interrupt cleared
- bit 1 **CWG2IF:** CWG2 Interrupt Flag bit
 1 = CWG2 has gone into shutdown
 0 = CWG3 is operating normally, or interrupt cleared
- bit 0 **CWG1IF:** CWG1 Interrupt Flag bit
 1 = CWG1 has gone into shutdown
 0 = CWG1 is operating normally, or interrupt cleared

Note: Interrupt flag bits are set when an interrupt condition occurs, regardless of the state of its corresponding enable bit or the Global Enable bit, GIE, of the INTCON register. User software should ensure the appropriate interrupt flag bits are clear prior to enabling an interrupt.

PIC16(L)F18856/76

REGISTER 7-20: PIR8: PERIPHERAL INTERRUPT REQUEST REGISTER 8

U-0	U-0	R/W/HS-0/0	R/W/HS-0/0	R/W/HS-0/0	R/W/HS-0/0	R/W/HS-0/0	R/W/HS-0/0
—	—	SMT2PWAIF	SMT2PRAIF	SMT2IF	SMT1PWAIF	SMT1PRAIF	SMT1IF
bit 7							bit 0

Legend:

R = Readable bit	W = Writable bit	U = Unimplemented bit, read as '0'
u = Bit is unchanged	x = Bit is unknown	-n/n = Value at POR and BOR/Value at all other Resets
'1' = Bit is set	'0' = Bit is cleared	HS = Hardware set

- bit 7-6 **Unimplemented:** Read as '0'.
- bit 5 **SMT2PWAIF:** SMT2 Pulse Width Acquisition Interrupt Flag bit
 1 = Interrupt is pending
 0 = Interrupt is not pending
- bit 4 **SMT2PRAIF:** SMT2 Period Acquisition Interrupt Flag bit
 1 = Interrupt is pending
 0 = Interrupt is not pending
- bit 3 **SMT2IF:** SMT2 Overflow Interrupt Flag bit
 1 = An SMT overflow event has occurred (must be cleared in software)
 0 = No overflow event detected
- bit 2 **SMT1PWAIF:** SMT1 Pulse Width Acquisition Interrupt Flag bit
 1 = Interrupt is pending
 0 = Interrupt is not pending
- bit 1 **SMT1PRAIF:** SMT1 Period Acquisition Interrupt Flag bit
 1 = Interrupt is pending
 0 = Interrupt is not pending
- bit 0 **SMT1IF:** SMT1 Overflow Interrupt Flag bit
 1 = An SMT overflow event has occurred (must be cleared in software)
 0 = No overflow event detected

Note: Interrupt flag bits are set when an interrupt condition occurs, regardless of the state of its corresponding enable bit or the Global Enable bit, GIE, of the INTCON register. User software should ensure the appropriate interrupt flag bits are clear prior to enabling an interrupt.

PIC16(L)F18856/76

TABLE 7-1: SUMMARY OF REGISTERS ASSOCIATED WITH INTERRUPTS

Name	Bit 7	Bit 6	Bit 5	Bit 4	Bit 3	Bit 2	Bit 1	Bit 0	Register on Page
INTCON	GIE	PEIE	—	—	—	—	—	INTEDG	134
PIE0	—	—	TMR0IE	IOIE	—	—	—	INTE	135
PIE1	OSFIE	CSWIE	—	—	—	—	ADTIE	ADIE	136
PIE2	—	ZCDIE	—	—	—	—	C2IE	C1IE	137
PIE3	—	—	RCIE	TXIE	BCL2IE	SSP2IE	BCL1IE	SSP1IE	138
PIE4	—	—	TMR6IE	TMR5IE	TMR4IE	TMR3IE	TMR2IE	TMR1IE	139
PIE5	CLC4IE	CLC3IE	CLC2IE	CLC1IE	—	TMR5GIE	TMR3GIE	TMR1GIE	140
PIE6	—	—	—	CCP5IE	CCP4IE	CCP3IE	CCP2IE	CCP1IE	141
PIE7	SCANIE	CRCIE	NVMIE	NCO1IE	—	CWG3IE	CWG2IE	CWG1IE	142
PIE8	—	—	SMT2PWAIE	SMT2PRAIE	SMT2IE	SMT1PWAIE	SMT1PRAIE	SMT1IE	143
PIR0	—	—	TMR0IF	IOCIF	—	—	—	INTF	144
PIR1	OSFIF	CSWIF	—	—	—	—	ADTIF	ADIF	145
PIR2	—	ZCDIF	—	—	—	—	C2IF	C1IF	146
PIR3	—	—	RCIF	TXIF	BCL2IF	SSP2IF	BCL1IF	SSP1IF	147
PIR4	—	—	TMR6IF	TMR5IF	TMR4IF	TMR3IF	TMR2IF	TMR1IF	148
PIR5	CLC4IF	CLC3IF	CLC2IF	CLC1IF	—	TMR5GIF	TMR3GIF	TMR1GIF	149
PIR6	—	—	—	CCP5IF	CCP4IF	CCP3IF	CCP2IF	CCP1IF	150
PIR7	SCANIF	CRCIF	NVMIF	NCO1IF	—	CWG3IF	CWG2IF	CWG1IF	152
PIR8	—	—	SMT2PWAIF	SMT2PRAIF	SMT2IF	SMT1PWAIF	SMT1PRAIF	SMT1IF	153

Legend: — = unimplemented location, read as '0'. Shaded cells are not used by interrupts.

PIC16(L)F18856/76

8.0 POWER-SAVING OPERATION MODES

The purpose of the Power-Down modes is to reduce power consumption. There are two Power-Down modes: DOZE mode and Sleep mode.

8.1 DOZE Mode

DOZE mode allows for power saving by reducing CPU operation and program memory (PFM) access, without affecting peripheral operation. DOZE mode differs from Sleep mode because the system oscillators continue to

operate, while only the CPU and PFM are affected. The reduced execution saves power by eliminating unnecessary operations within the CPU and memory.

When the Doze Enable (DOZEN) bit is set (DOZEN = 1), the CPU executes only one instruction cycle out of every N cycles as defined by the DOZE<2:0> bits of the CPUDOZE register. For example, if DOZE<2:0> = 100, the instruction cycle ratio is 1:32. The CPU and memory execute for one instruction cycle and then lay idle for 31 instruction cycles. During the unused cycles, the peripherals continue to operate at the system clock speed.

FIGURE 8-1: DOZE MODE OPERATION EXAMPLE

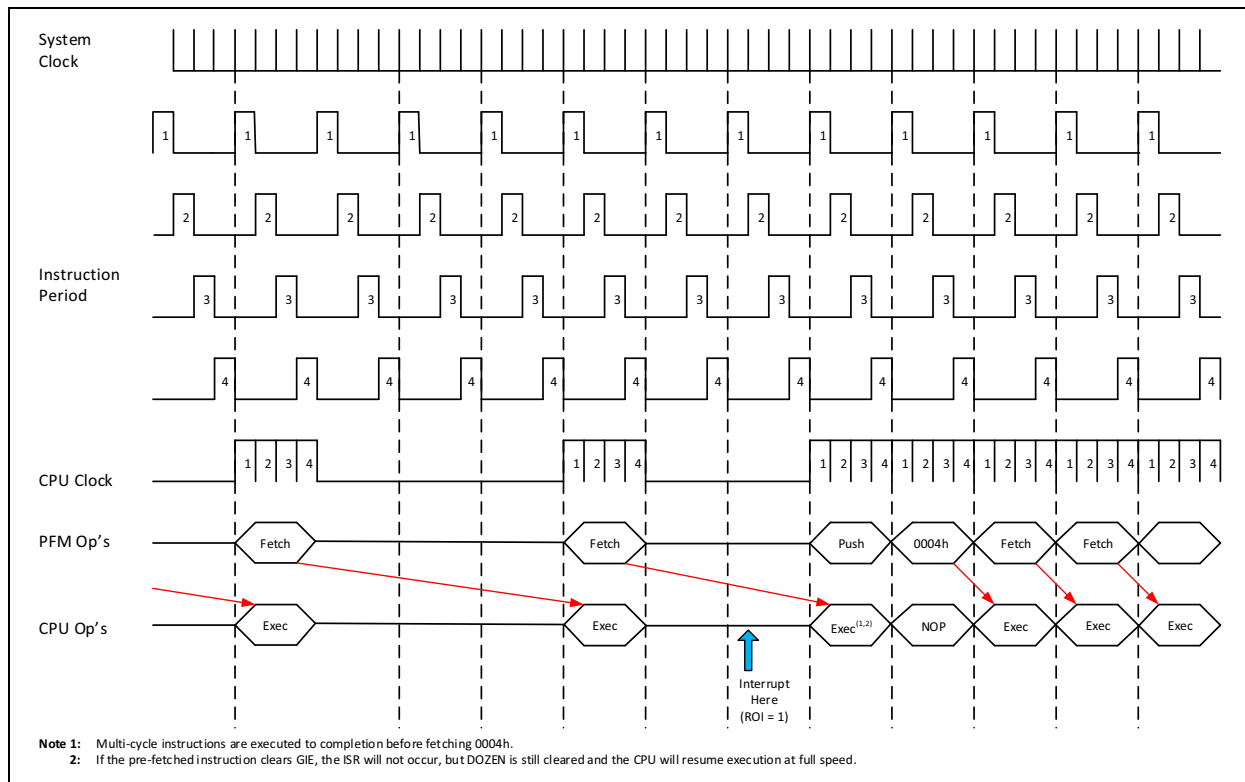

8.1.1 DOZE OPERATION

The Doze operation is illustrated in Figure 8-1. For this example:

- Doze enable (DOZEN) bit set (DOZEN = 1)
- DOZE<2:0> = 001 (1:4) ratio
- Recover-on-Interrupt (ROI) bit set (ROI = 1)

As with normal operation, the PFM fetches for the next instruction cycle. The Q-clocks to the peripherals continue throughout.

8.1.2 INTERRUPTS DURING DOZE

If an interrupt occurs and the Recover-On-Interrupt bit is clear (ROI = 0) at the time of the interrupt, the Interrupt Service Routine (ISR) continues to execute at the rate selected by DOZE<2:0>. Interrupt latency is extended by the DOZE<2:0> ratio.

If an interrupt occurs and the ROI bit is set (ROI = 1) at the time of the interrupt, the DOZEN bit is cleared and the CPU executes at full speed. The prefetched instruction is executed and then the interrupt vector sequence is executed. In [Figure 8-1](#), the interrupt occurs during the 2nd instruction cycle of the Doze period, and immediately brings the CPU out of Doze. If the Doze-On-Exit (DOE) bit is set (DOE = 1) when the RETFIE operation is executed, DOZEN is set, and the CPU executes at the reduced rate based on the DOZE<2:0> ratio.

8.2 Sleep Mode

Sleep mode is entered by executing the SLEEP instruction, while the Idle Enable (IDLEN) bit of the CPUDOZE register is clear (IDLEN = 0). If the SLEEP instruction is executed while the IDLEN bit is set (IDLEN = 1), the CPU will enter the IDLE mode ([Section 8.2.3 “Low-Power Sleep Mode”](#)).

Upon entering Sleep mode, the following conditions exist:

1. WDT will be cleared but keeps running if enabled for operation during Sleep
2. The \overline{PD} bit of the STATUS register is cleared
3. The \overline{TO} bit of the STATUS register is set
4. The CPU clock is disabled
5. 31 kHz LFINTOSC, HFINTOSC and SOSC are unaffected and peripherals using them may continue operation in Sleep.
6. Timer1 and peripherals that use it continue to operate in Sleep when the Timer1 clock source selected is:
 - LFINTOSC
 - T1CKI
 - Secondary Oscillator
7. ADC is unaffected if the dedicated FRC oscillator is selected
8. I/O ports maintain the status they had before Sleep was executed (driving high, low, or high-impedance)
9. Resets other than WDT are not affected by Sleep mode

Refer to individual chapters for more details on peripheral operation during Sleep.

To minimize current consumption, the following conditions should be considered:

- I/O pins should not be floating
- External circuitry sinking current from I/O pins
- Internal circuitry sourcing current from I/O pins
- Current draw from pins with internal weak pull-ups
- Modules using any oscillator

I/O pins that are high-impedance inputs should be pulled to VDD or VSS externally to avoid switching currents caused by floating inputs.

Examples of internal circuitry that might be sourcing current include modules such as the DAC and FVR modules. See [Section 25.0 “5-Bit Digital-to-Analog Converter \(DAC1\) Module”](#) and [16.0 “Fixed Voltage Reference \(FVR\)”](#) for more information on these modules.

8.2.1 WAKE-UP FROM SLEEP

The device can wake-up from Sleep through one of the following events:

1. External Reset input on \overline{MCLR} pin, if enabled.
2. BOR Reset, if enabled.
3. POR Reset.
4. Watchdog Timer, if enabled.
5. Any external interrupt.
6. Interrupts by peripherals capable of running during Sleep (see individual peripheral for more information).

The first three events will cause a device Reset. The last three events are considered a continuation of program execution. To determine whether a device Reset or wake-up event occurred, refer to [Section 5.11 “Determining the Cause of a Reset”](#).

When the SLEEP instruction is being executed, the next instruction (PC + 1) is prefetched. For the device to wake-up through an interrupt event, the corresponding interrupt enable bit must be enabled. Wake-up will occur regardless of the state of the GIE bit. If the GIE bit is disabled, the device continues execution at the instruction after the SLEEP instruction. If the GIE bit is enabled, the device executes the instruction after the SLEEP instruction, the device will then call the Interrupt Service Routine. In cases where the execution of the instruction following SLEEP is not desirable, the user should have a NOP after the SLEEP instruction.

The WDT is cleared when the device wakes-up from Sleep, regardless of the source of wake-up.

PIC16(L)F18856/76

8.2.2 WAKE-UP USING INTERRUPTS

When global interrupts are disabled (GIE cleared) and any interrupt source, with the exception of the clock switch interrupt, has both its interrupt enable bit and interrupt flag bit set, one of the following will occur:

- If the interrupt occurs **before** the execution of a SLEEP instruction
 - SLEEP instruction will execute as a NOP
 - WDT and WDT prescaler will not be cleared
 - \overline{TO} bit of the STATUS register will not be set
 - \overline{PD} bit of the STATUS register will not be cleared

- If the interrupt occurs **during or after** the execution of a SLEEP instruction
 - SLEEP instruction will be completely executed
 - Device will immediately wake-up from Sleep
 - WDT and WDT prescaler will be cleared
 - \overline{TO} bit of the STATUS register will be set
 - \overline{PD} bit of the STATUS register will be cleared

Even if the flag bits were checked before executing a SLEEP instruction, it may be possible for flag bits to become set before the SLEEP instruction completes. To determine whether a SLEEP instruction executed, test the PD bit. If the \overline{PD} bit is set, the SLEEP instruction was executed as a NOP.

FIGURE 8-2: WAKE-UP FROM SLEEP THROUGH INTERRUPT

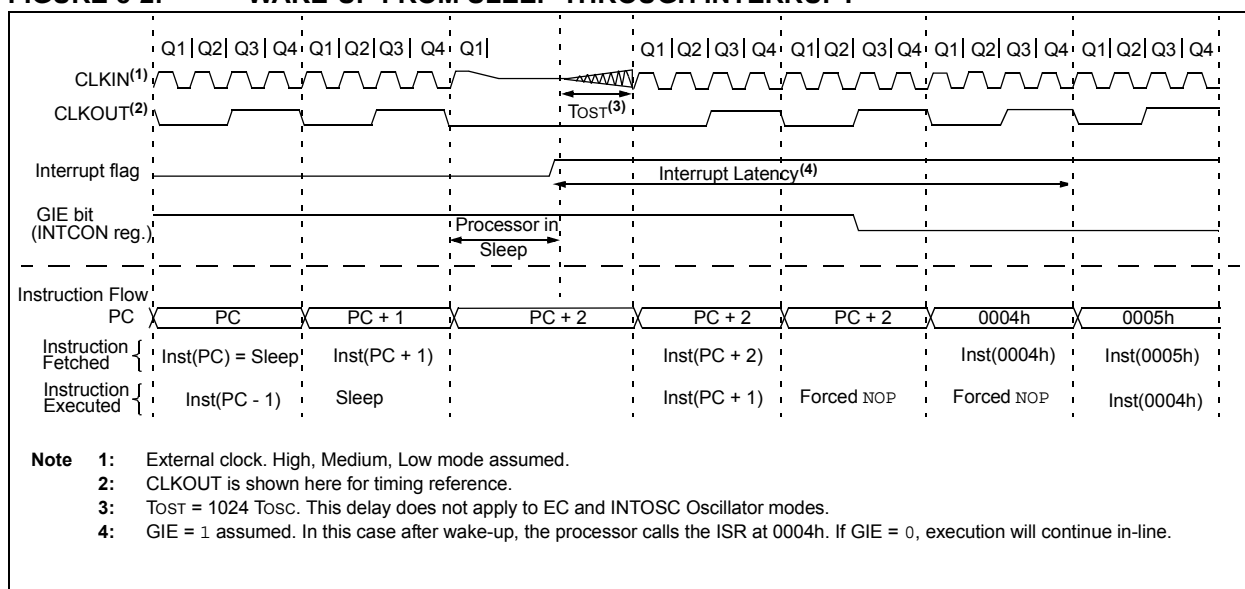

8.2.3 LOW-POWER SLEEP MODE

The PIC16F18855/75 device contains an internal Low Dropout (LDO) voltage regulator, which allows the device I/O pins to operate at voltages up to 5.5V while the internal device logic operates at a lower voltage. The LDO and its associated reference circuitry must remain active when the device is in Sleep mode.

The PIC16F18855/75 allows the user to optimize the operating current in Sleep, depending on the application requirements.

Low-Power Sleep mode can be selected by setting the VREGPM bit of the VREGCON register. Depending on the configuration of these bits, the LDO and reference circuitry are placed in a low-power state when the device is in Sleep.

8.2.3.1 Sleep Current vs. Wake-up Time

In the default operating mode, the LDO and reference circuitry remain in the normal configuration while in Sleep. The device is able to exit Sleep mode quickly since all circuits remain active. In Low-Power Sleep mode, when waking-up from Sleep, an extra delay time is required for these circuits to return to the normal configuration and stabilize.

The Low-Power Sleep mode is beneficial for applications that stay in Sleep mode for long periods of time. The Normal mode is beneficial for applications that need to wake from Sleep quickly and frequently.

PIC16(L)F18856/76

8.2.3.2 Peripheral Usage in Sleep

Some peripherals that can operate in Sleep mode will not operate properly with the Low-Power Sleep mode selected. The Low-Power Sleep mode is intended for use with these peripherals:

- Brown-out Reset (BOR)
- Watchdog Timer (WDT)
- External interrupt pin/interrupt-on-change pins
- Timer1 (with external clock source)

It is the responsibility of the end user to determine what is acceptable for their application when setting the VREGPM settings in order to ensure operation in Sleep.

Note: The PIC16LF18855/75 does not have a configurable Low-Power Sleep mode. PIC16LF18855/75 is an unregulated device and is always in the lowest power state when in Sleep, with no wake-up time penalty. This device has a lower maximum VDD and I/O voltage than the PIC16F18855/75. See [Section 37.0 “Electrical Specifications”](#) for more information.

8.2.4 IDLE MODE

When the Idle Enable (IDLEN) bit is clear (IDLEN = 0), the SLEEP instruction will put the device into full Sleep mode (see [Section 8.2 “Sleep Mode”](#)). When IDLEN is set (IDLEN = 1), the SLEEP instruction will put the device into IDLE mode. In IDLE mode, the CPU and memory operations are halted, but the peripheral clocks continue to run. This mode is similar to DOZE mode, except that in IDLE both the CPU and PFM are shut off.

Note: Peripherals using FOSC will continue running while in Idle (but not in Sleep). Peripherals using HFINTOSC, LFINTOSC, or SOSC will continue running in both Idle and Sleep.

Note: If CLKOUT is enabled (CLKOUT = 0, Configuration Word 1), the output will continue operating while in Idle.

8.2.4.1 Idle and Interrupts

IDLE mode ends when an interrupt occurs (even if GIE = 0), but IDLEN is not changed. The device can re-enter IDLE by executing the SLEEP instruction.

If Recover-on-Interrupt is enabled (ROI = 1), the interrupt that brings the device out of Idle also restores full-speed CPU execution when doze is also enabled.

8.2.4.2 Idle and WDT

When in Idle, the WDT Reset is blocked and will instead wake the device. The WDT wake-up is not an interrupt, therefore ROI does not apply.

Note: The WDT can bring the device out of Idle, in the same way it brings the device out of Sleep. The DOZEN bit is not affected.

PIC16(L)F18856/76

8.3 Register Definitions: Voltage Regulator and DOZE Control

REGISTER 8-1: VREGCON: VOLTAGE REGULATOR CONTROL REGISTER ⁽¹⁾

U-0	U-0	U-0	U-0	U-0	U-0	R/W-0/0	R/W-1/1
—	—	—	—	—	—	VREGPM	Reserved
bit 7							bit 0

Legend:

R = Readable bit	W = Writable bit	U = Unimplemented bit, read as '0'
u = Bit is unchanged	x = Bit is unknown	-n/n = Value at POR and BOR/Value at all other Resets
'1' = Bit is set	'0' = Bit is cleared	

- bit 7-2 **Unimplemented:** Read as '0'
- bit 1 **VREGPM:** Voltage Regulator Power Mode Selection bit
 - 1 = Low-Power Sleep mode enabled in Sleep⁽²⁾
Draws lowest current in Sleep, slower wake-up
 - 0 = Normal Power mode enabled in Sleep⁽²⁾
Draws higher current in Sleep, faster wake-up
- bit 0 **Reserved:** Read as '1'. Maintain this bit set.

- Note 1:** PIC16F18855/75 only.
2: See [Section 37.0 "Electrical Specifications"](#).

PIC16(L)F18856/76

REGISTER 8-2: CPUDOZE: DOZE AND IDLE REGISTER

R/W-0/u	R/W/HC/HS-0/0	R/W-0/0	R/W-0/0	U-0	R/W-0/0	R/W-0/0	R/W-0/0
IDLEN	DOZEN ^(1,2)	ROI	DOE	—	DOZE<2:0>		
bit 7							bit 0

Legend:

HC = Bit is cleared by hardware

HS = Bit is set by hardware

R = Readable bit

W = Writable bit

U = Unimplemented bit, read as '0'

u = Bit is unchanged

x = Bit is unknown

-n/n = Value at POR and BOR/Value at all other Resets

'1' = Bit is set

'0' = Bit is cleared

- bit 7 **IDLEN:** Idle Enable bit
 1 = A SLEEP instruction inhibits the CPU clock, but not the peripheral clock(s)
 0 = A SLEEP instruction places the device into full Sleep mode
- bit 6 **DOZEN:** Doze Enable bit^(1,2)
 1 = The CPU executes instruction cycles according to DOZE setting
 0 = The CPU executes all instruction cycles (fastest, highest power operation)
- bit 5 **ROI:** Recover-on-Interrupt bit
 1 = Entering the Interrupt Service Routine (ISR) makes DOZEN = 0 bit, bringing the CPU to full-speed operation.
 0 = Interrupt entry does not change DOZEN
- bit 4 **DOE:** Doze on Exit bit
 1 = Executing RETFIE makes DOZEN = 1, bringing the CPU to reduced speed operation.
 0 = RETFIE does not change DOZEN
- bit 3 **Unimplemented:** Read as '0'
- bit 2-0 **DOZE<2:0>:** Ratio of CPU Instruction Cycles to Peripheral Instruction Cycles
 111 = 1:256
 110 = 1:128
 101 = 1:64
 100 = 1:32
 011 = 1:16
 010 = 1:8
 001 = 1:4
 000 = 1:2

- Note 1:** When ROI = 1 or DOE = 1, DOZEN is changed by hardware interrupt entry and/or exit.
Note 2: Entering ICD overrides DOZEN, returning the CPU to full execution speed; this bit is not affected.

PIC16(L)F18856/76

TABLE 8-1: SUMMARY OF REGISTERS ASSOCIATED WITH POWER-DOWN MODE

Name	Bit 7	Bit 6	Bit 5	Bit 4	Bit 3	Bit 2	Bit 1	Bit 0	Register on Page
INTCON	GIE	PEIE	—	—	—	—	—	INTEDG	134
PIE0	—	—	TMR0IE	IOIE	—	—	—	INTE	135
PIE1	OSFIE	CSWIE	—	—	—	—	ADTIE	ADIE	136
PIE2	—	ZCDIE	—	—	—	—	C2IE	C1IE	137
PIE3	—	—	RCIE	TXIE	BCL2IE	SSP2IE	BCL1IE	SSP1IE	138
PIE4	—	—	TMR6IE	TMR5IE	TMR4IE	TMR3IE	TMR2IE	TMR1IE	139
PIR0	—	—	TMR0IF	IOCF	—	—	—	INTF	144
PIR1	OSFIF	CSWIF	—	—	—	—	ADTIF	ADIF	145
PIR2	—	ZCDIF	—	—	—	—	C2IF	C1IF	146
PIR3	—	—	RCIF	TXIF	BCL2IF	SSP2IF	BCL1IF	SSP1IF	147
PIR4	—	—	TMR6IF	TMR5IF	TMR4IF	TMR3IF	TMR2IF	TMR1IF	148
IOCAP	IOCAP7	IOCAP6	IOCAP5	IOCAP4	IOCAP3	IOCAP2	IOCAP1	IOCAP0	262
IOCAN	IOCAN7	IOCAN6	IOCAN5	IOCAN4	IOCAN3	IOCAN2	IOCAN1	IOCAN0	262
IOCAF	IOCAF7	IOCAF6	IOCAF5	IOCAF4	IOCAF3	IOCAF2	IOCAF1	IOCAF0	262
IOCCP	IOCCP7	IOCCP6	IOCCP5	IOCCP4	IOCCP3	IOCCP2	IOCCP1	IOCCP0	264
IOCBP	IOCBP7	IOCBP6	IOCBP5	IOCBP4	IOCBP3	IOCBP2	IOCBP1	IOCBP0	263
IOCBN	IOCBN7	IOCBN6	IOCBN5	IOCBN4	IOCBN3	IOCBN2	IOCBN1	IOCBN0	263
IOCBF	IOCBF7	IOCBF6	IOCBF5	IOCBF4	IOCBF3	IOCBF2	IOCBF1	IOCBF0	263
IOCCN	IOCCN7	IOCCN6	IOCCN5	IOCCN4	IOCCN3	IOCCN2	IOCCN1	IOCCN0	264
IOCCF	IOCCF7	IOCCF6	IOCCF5	IOCCF4	IOCCF3	IOCCF2	IOCCF1	IOCCF0	264
IOCEP	—	—	—	—	IOCEP3	—	—	—	265
IOCEN	—	—	—	—	IOCEN3	—	—	—	265
IOCEF	—	—	—	—	IOCEF3	—	—	—	266
STATUS	—	—	—	\overline{TO}	\overline{PD}	Z	DC	C	38
VREGCON	—	—	—	—	—	—	VREGPM	Reserved	159
CPUDOZE	IDLEN	DOZEN	ROI	DOE	—	DOZE<2:0>			160
WDTCN0	—	—	WDTPS<4:0>					SWDTEN	166
IOCEP	—	—	—	—	IOCEP3	—	—	—	265
IOCEN	—	—	—	—	IOCEN3	—	—	—	265
IOCEF	—	—	—	—	IOCEF3	—	—	—	266

Legend: — = unimplemented location, read as '0'. Shaded cells are not used in Power-Down mode.

9.0 WINDOWED WATCHDOG TIMER (WWDT)

The Watchdog Timer (WDT) is a system timer that generates a Reset if the firmware does not issue a CLRWDT instruction within the time-out period. The Watchdog Timer is typically used to recover the system from unexpected events. The Windowed Watchdog Timer (WDT) differs in that CLRWDT instructions are only accepted when they are performed within a specific window during the time-out period.

The WDT has the following features:

- Selectable clock source
- Multiple operating modes
 - WDT is always on
 - WDT is off when in Sleep
 - WDT is controlled by software
 - WDT is always off
- Configurable time-out period is from 1 ms to 256 seconds (nominal)
- Configurable window size from 12.5 to 100 percent of the time-out period
- Multiple Reset conditions
- Operation during Sleep

PIC16(L)F18856/76

FIGURE 9-1: WATCHDOG TIMER BLOCK DIAGRAM

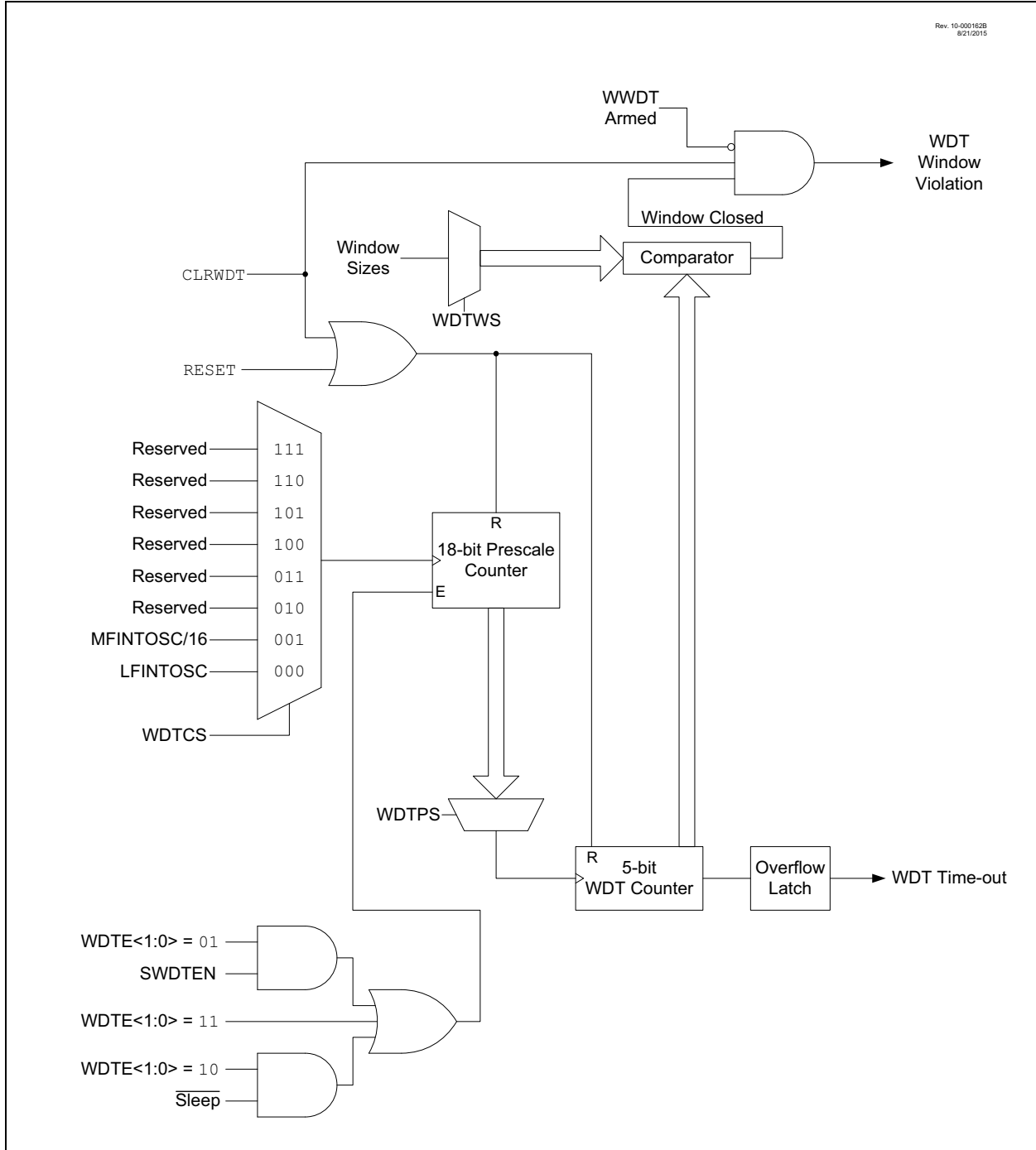

PIC16(L)F18856/76

9.1 Independent Clock Source

The WDT can derive its time base from either the 31 kHz LFINTOSC or 31.25 kHz MFINTOSC/16 internal oscillators, depending on the value of either the WDTCCS<2:0> Configuration bits or the WDTCS<2:0> bits of WDTCON1. Time intervals in this chapter are based on a minimum nominal interval of 1 ms. See [Section 37.0 “Electrical Specifications”](#) for LFINTOSC and MFINTOSC tolerances.

9.2 WDT Operating Modes

The Watchdog Timer module has four operating modes controlled by the WDTE<1:0> bits in Configuration Words. See [Table 9-1](#).

9.2.1 WDT IS ALWAYS ON

When the WDTE bits of Configuration Words are set to ‘11’, the WDT is always on.

WDT protection is active during Sleep.

9.2.2 WDT IS OFF IN SLEEP

When the WDTE bits of Configuration Words are set to ‘10’, the WDT is on, except in Sleep.

WDT protection is not active during Sleep.

9.2.3 WDT CONTROLLED BY SOFTWARE

When the WDTE bits of Configuration Words are set to ‘01’, the WDT is controlled by the SEN bit of the WDTCON0 register.

WDT protection is unchanged by Sleep. See [Table 9-1](#) for more details.

TABLE 9-1: WDT OPERATING MODES

WDTE<1:0>	SEN	Device Mode	WDT Mode
11	X	X	Active
10	X	Awake	Active
		Sleep	Disabled
01	1	X	Active
	0	X	Disabled
00	X	X	Disabled

9.3 Time-Out Period

The WDTPS bits of the WDTCON0 register set the time-out period from 1 ms to 256 seconds (nominal). After a Reset, the default time-out period is two seconds.

9.4 Watchdog Window

The Watchdog Timer has an optional Windowed mode that is controlled by the WDTCWS<2:0> Configuration bits and WINDOW<2:0> bits of the WDTCON1 register. In the Windowed mode, the CLRWDT instruction must occur within the allowed window of the WDT period. Any CLRWDT instruction that occurs outside of this window will trigger a window violation and will cause a WDT Reset, similar to a WDT time out. See [Figure 9-2](#) for an example.

The window size is controlled by the WDTCWS<2:0> Configuration bits, or the WINDOW<2:0> bits of WDTCON1, if WDTCWS<2:0> = 111.

In the event of a window violation, a Reset will be generated and the WDTWV bit of the PCON register will be cleared. This bit is set by a POR or can be set in firmware.

9.5 Clearing the WDT

The WDT is cleared when any of the following conditions occur:

- Any Reset
- Valid CLRWDT instruction is executed
- Device enters Sleep
- Device wakes up from Sleep
- WDT is disabled
- Oscillator Start-up Timer (OST) is running
- Any write to the WDTCON0 or WDTCON1 registers

9.5.1 CLRWDT CONSIDERATIONS (WINDOWED MODE)

When in Windowed mode, the WDT must be armed before a CLRWDT instruction will clear the timer. This is performed by reading the WDTCON0 register. Executing a CLRWDT instruction without performing such an arming action will trigger a window violation.

See [Table 9-2](#) for more information.

9.6 Operation During Sleep

When the device enters Sleep, the WDT is cleared. If the WDT is enabled during Sleep, the WDT resumes counting. When the device exits Sleep, the WDT is cleared again.

The WDT remains clear until the OST, if enabled, completes. See [Section 6.0 “Oscillator Module \(with Fail-Safe Clock Monitor\)”](#) for more information on the OST.

When a WDT time-out occurs while the device is in Sleep, no Reset is generated. Instead, the device wakes up and resumes operation. The TO and PD bits in the STATUS register are changed to indicate the event. The RWDT bit in the PCON register can also be used. See [Section 3.0 “Memory Organization”](#) for more information.

PIC16(L)F18856/76

TABLE 9-2: WDT CLEARING CONDITIONS

Conditions	WDT
WDTE<1:0> = 00	Cleared
WDTE<1:0> = 01 and SEN = 0	
WDTE<1:0> = 10 and enter Sleep	
CLRWDT Command	
Oscillator Fail Detected	
Exit Sleep + System Clock = T1OSC, EXTRC, INTOSC, EXTCLK	
Change INTOSC divider (IRCF bits)	Unaffected

FIGURE 9-2: WINDOW PERIOD AND DELAY

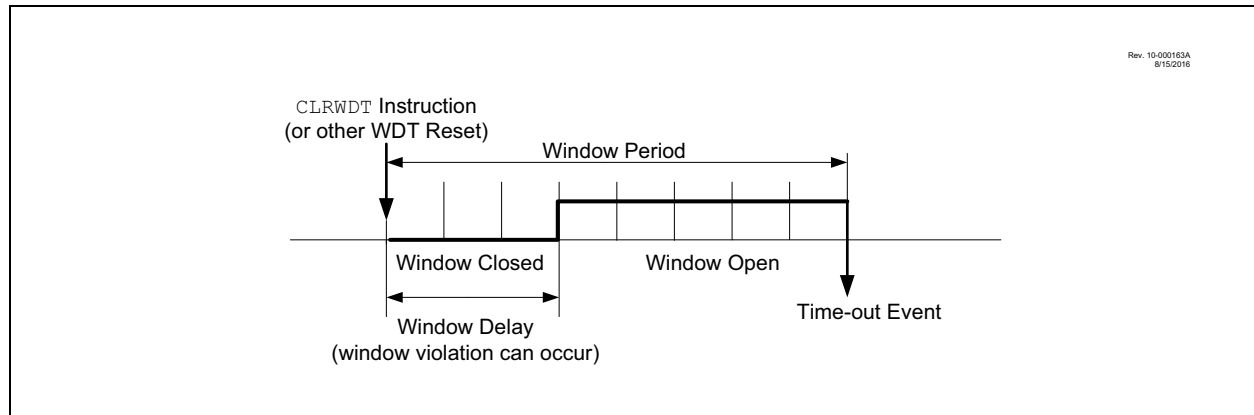

PIC16(L)F18856/76

9.7 Register Definitions: Windowed Watchdog Timer Control

REGISTER 9-1: WDTCON0: WATCHDOG TIMER CONTROL REGISTER 0

U-0	U-0	R/W ⁽³⁾ -q/q ⁽²⁾	R/W ⁽³⁾ -q/q ⁽²⁾	R/W ⁽³⁾ -q/q ⁽²⁾	R/W ⁽³⁾ -q/q ⁽²⁾	R/W ⁽³⁾ -q/q ⁽²⁾	R/W-0/0
—	—	WDTPS<4:0> ⁽¹⁾					SEN
bit 7							bit 0

Legend:

R = Readable bit	W = Writable bit	U = Unimplemented bit, read as '0'
u = Bit is unchanged	x = Bit is unknown	-n/n = Value at POR and BOR/Value at all other Resets
'1' = Bit is set	'0' = Bit is cleared	q = Value depends on condition

bit 7-6 **Unimplemented:** Read as '0'

bit 5-1 **WDTPS<4:0>:** Watchdog Timer Prescale Select bits⁽¹⁾

Bit Value = Prescale Rate

11111 = Reserved. Results in minimum interval (1:32)

.

.

.

10011 = Reserved. Results in minimum interval (1:32)

10010 = 1:8388608 (2²³) (Interval 256s nominal)

10001 = 1:4194304 (2²²) (Interval 128s nominal)

10000 = 1:2097152 (2²¹) (Interval 64s nominal)

01111 = 1:1048576 (2²⁰) (Interval 32s nominal)

01110 = 1:524288 (2¹⁹) (Interval 16s nominal)

01101 = 1:262144 (2¹⁸) (Interval 8s nominal)

01100 = 1:131072 (2¹⁷) (Interval 4s nominal)

01011 = 1:65536 (Interval 2s nominal) (Reset value)

01010 = 1:32768 (Interval 1s nominal)

01001 = 1:16384 (Interval 512 ms nominal)

01000 = 1:8192 (Interval 256 ms nominal)

00111 = 1:4096 (Interval 128 ms nominal)

00110 = 1:2048 (Interval 64 ms nominal)

00101 = 1:1024 (Interval 32 ms nominal)

00100 = 1:512 (Interval 16 ms nominal)

00011 = 1:256 (Interval 8 ms nominal)

00010 = 1:128 (Interval 4 ms nominal)

00001 = 1:64 (Interval 2 ms nominal)

00000 = 1:32 (Interval 1 ms nominal)

bit 0 **SEN:** Software Enable/Disable for Watchdog Timer bit

If WDTE<1:0> = 1x:

This bit is ignored.

If WDTE<1:0> = 01:

1 = WDT is turned on

0 = WDT is turned off

If WDTE<1:0> = 00:

This bit is ignored.

Note 1: Times are approximate. WDT time is based on 31 kHz LFINTOSC.

2: When WDTCPS <4:0> in CONFIG3 = 11111, the Reset value of WDTPS<4:0> is 01011. Otherwise, the Reset value of WDTPS<4:0> is equal to WDTCPS<4:0> in CONFIG3.

3: When WDTCPS <4:0> in CONFIG3 ≠ 11111, these bits are read-only.

PIC16(L)F18856/76

REGISTER 9-2: WDTCON1: WATCHDOG TIMER CONTROL REGISTER 1

U-0	R/W ⁽³⁾ -q/q ⁽¹⁾	R/W ⁽³⁾ -q/q ⁽¹⁾	R/W ⁽³⁾ -q/q ⁽¹⁾	U-0	R/W ⁽⁴⁾ -q/q ⁽²⁾	R/W ⁽⁴⁾ -q/q ⁽²⁾	R/W ⁽⁴⁾ -q/q ⁽²⁾
—	WDTCS<2:0>			—	WINDOW<2:0>		
bit 7							bit 0

Legend:

R = Readable bit	W = Writable bit	U = Unimplemented bit, read as '0'
u = Bit is unchanged	x = Bit is unknown	-n/n = Value at POR and BOR/Value at all other Resets
'1' = Bit is set	'0' = Bit is cleared	q = Value depends on condition

- bit 7 **Unimplemented:** Read as '0'
- bit 6-4 **WDTCS<2:0>:** Watchdog Timer Clock Select bits
 111 = Reserved
 .
 .
 .
 010 = Reserved
 001 = MFINTOSC/16 (31.25 kHz)
 000 = LFINTOSC (31 kHz)
- bit 3 **Unimplemented:** Read as '0'
- bit 2-0 **WINDOW<2:0>:** Watchdog Timer Window Select bits

WINDOW<2:0>	Window delay Percent of time	Window opening Percent of time
111	N/A	100
110	12.5	87.5
101	25	75
100	37.5	62.5
011	50	50
010	62.5	37.5
001	75	25
000	87.5	12.5

- Note 1:** If WDTCCS <2:0> in CONFIG3 = 111, the Reset value of WDTCS<2:0> is 000.
- 2:** The Reset value of WINDOW<2:0> is determined by the value of WDTCWS<2:0> in the CONFIG3 register.
- 3:** If WDTCCS<2:0> in CONFIG3 ≠ 111, these bits are read-only.
- 4:** If WDTCWS<2:0> in CONFIG3 ≠ 111, these bits are read-only.

PIC16(L)F18856/76

REGISTER 9-3: WDTPSL: WDT PRESCALE SELECT LOW BYTE REGISTER (READ-ONLY)

R-0/0	R-0/0	R-0/0	R-0/0	R-0/0	R-0/0	R-0/0	R-0/0
PSCNT<7:0> ⁽¹⁾							
bit 7							bit 0

Legend:

R = Readable bit	W = Writable bit	U = Unimplemented bit, read as '0'
u = Bit is unchanged	x = Bit is unknown	-n/n = Value at POR and BOR/Value at all other Resets
'1' = Bit is set	'0' = Bit is cleared	

bit 7-0 **PSCNT<7:0>**: Prescale Select Low Byte bits⁽¹⁾

Note 1: The 18-bit WDT prescale value, PSCNT<17:0> includes the WDTPSL, WDTPSH and the lower bits of the WDTTMR registers. PSCNT<17:0> is intended for debug operations and should be read during normal operation.

REGISTER 9-4: WDTPSH: WDT PRESCALE SELECT HIGH BYTE REGISTER (READ-ONLY)

R-0/0	R-0/0	R-0/0	R-0/0	R-0/0	R-0/0	R-0/0	R-0/0
PSCNT<15:8> ⁽¹⁾							
bit 7							bit 0

Legend:

R = Readable bit	W = Writable bit	U = Unimplemented bit, read as '0'
u = Bit is unchanged	x = Bit is unknown	-n/n = Value at POR and BOR/Value at all other Resets
'1' = Bit is set	'0' = Bit is cleared	

bit 7-0 **PSCNT<15:8>**: Prescale Select High Byte bits⁽¹⁾

Note 1: The 18-bit WDT prescale value, PSCNT<17:0> includes the WDTPSL, WDTPSH and the lower bits of the WDTTMR registers. PSCNT<17:0> is intended for debug operations and should be read during normal operation.

REGISTER 9-5: WDTTMR: WDT TIMER REGISTER (READ-ONLY)

U-0	R-0/0	R-0/0	R-0/0	R-0/0	R-0/0	R-0/0	R-0/0
—	WDTTMR<3:0>				STATE	PSCNT<17:16> ⁽¹⁾	
bit 7							bit 0

Legend:

R = Readable bit	W = Writable bit	U = Unimplemented bit, read as '0'
u = Bit is unchanged	x = Bit is unknown	-n/n = Value at POR and BOR/Value at all other Resets
'1' = Bit is set	'0' = Bit is cleared	

bit 7 **Unimplemented:** Read as '0'

bit 6-3 **WDTTMR<3:0>**: Watchdog Timer Value bits

bit 2 **STATE:** WDT Armed Status bit

1 = WDT is armed
0 = WDT is not armed

bit 1-0 **PSCNT<17:16>**: Prescale Select Upper Byte bits⁽¹⁾

Note 1: The 18-bit WDT prescale value, PSCNT<17:0> includes the WDTPSL, WDTPSH and the lower bits of the WDTTMR registers. PSCNT<17:0> is intended for debug operations and should be read during normal operation.

PIC16(L)F18856/76

TABLE 9-3: SUMMARY OF REGISTERS ASSOCIATED WITH WATCHDOG TIMER

Name	Bit 7	Bit 6	Bit 5	Bit 4	Bit 3	Bit 2	Bit 1	Bit 0	Register on Page
OSCCON1	—	NOSC<2:0>			NDIV<3:0>				122
OSCCON2	—	COSC<2:0>			CDIV<3:0>				122
OSCCON3	CSWHOLD	SOSCPWR	—	ORDY	NOSCR	—	—	—	123
PCON0	STKOVF	STKUNF	WDTWV	RWD \bar{T}	RMCLR	R \bar{I}	POR	BOR	109
STATUS	—	—	—	T \bar{O}	P \bar{D}	Z	DC	C	38
WDTCON0	—	—	WDTPS<4:0>					SEN	166
WDTCON1	—	WDTCS<2:0>			—	WINDOW<2:0>			166
WDTPSL	PSCNT<7:0>								166
WDTPSH	PSCNT<15:8>								166
WDTTMR	—	WDTTMR<4:0>				STATE	PSCNT<17:16>		166

Legend: — = unimplemented locations read as '0'. Shaded cells are not used by Watchdog Timer.

TABLE 9-4: SUMMARY OF CONFIGURATION WORD WITH WATCHDOG TIMER

Name	Bits	Bit -/7	Bit -/6	Bit 13/5	Bit 12/4	Bit 11/3	Bit 10/2	Bit 9/1	Bit 8/0	Register on Page
CONFIG1	13:8	—	—	FCMEN	—	CSWEN	—	—	CLKOUTEN	93
	7:0	—	RSTOSC<2:0>			—	FEXTOSC<2:0>			

Legend: — = unimplemented location, read as '0'. Shaded cells are not used by clock sources.

PIC16(L)F18856/76

10.0 NONVOLATILE MEMORY (NVM) CONTROL

NVM is separated into two types: Program Flash Memory (PFM) and Data EEPROM Memory.

NVM is accessible by using both the FSR and INDF registers, or through the NVMREG register interface.

The write time is controlled by an on-chip timer. The write/erase voltages are generated by an on-chip charge pump rated to operate over the operating voltage range of the device.

NVM can be protected in two ways; by either code protection or write protection.

Code protection (\overline{CP} and \overline{CPD} bits in Configuration Word 5) disables access, reading and writing, to both the PFM and EEPROM via external device programmers. Code protection does not affect the self-write and erase functionality. Code protection can only be Reset by a device programmer performing a Bulk Erase to the device, clearing all nonvolatile memory, Configuration bits, and User IDs.

Write protection prohibits self-write and erase to a portion or all of the PFM, as defined by the WRT<1:0> bits of Configuration Word 4. Write protection does not affect a device programmer's ability to read, write, or erase the device.

10.1 Program Flash Memory (PFM)

PFM consists of an array of 14-bit words as user memory, with additional words for User ID information, Configuration words, and interrupt vectors. PFM provides storage locations for:

- User program instructions
- User defined data

PFM data can be read and/or written to through:

- CPU instruction fetch (read-only)
- FSR/INDF indirect access (read-only) ([Section 10.3 "FSR and INDF Access"](#))
- NVMREG access ([Section 10.4 "NVMREG Access"](#))
- In-Circuit Serial Programming™ (ICSP™)

Read operations return a single word of memory. When write and erase operations are done on a row basis, the row size is defined in [Table 10-1](#). PFM will erase to a logic '1' and program to a logic '0'.

TABLE 10-1: FLASH MEMORY ORGANIZATION BY DEVICE

Device	Row Erase (words)	Write Latches (words)	Total Program Flash (words)
PIC16(L)F18856	32	32	16384
PIC16(L)F18876			

It is important to understand the PFM memory structure for erase and programming operations. PFM is arranged in rows. A row consists of 32 14-bit program memory words. A row is the minimum size that can be erased by user software.

After a row has been erased, all or a portion of this row can be programmed. Data to be written into the program memory row is written to 14-bit wide data write latches. These latches are not directly accessible, but may be loaded via sequential writes to the NVMDATH:NVMDATL register pair.

Note: To modify only a portion of a previously programmed row, then the contents of the entire row must be read and saved in RAM prior to the erase. Then, the new data and retained data can be written into the write latches to reprogram the row of PFM. However, any unprogrammed locations can be written without first erasing the row. In this case, it is not necessary to save and rewrite the other previously programmed locations

10.1.1 PROGRAM MEMORY VOLTAGES

The PFM is readable and writable during normal operation over the full VDD range.

10.1.1.1 Programming Externally

The program memory cell and control logic support write and Bulk Erase operations down to the minimum device operating voltage. Special BOR operation is enabled during Bulk Erase ([Section 5.2.4 "BOR is always OFF"](#)).

10.1.1.2 Self-programming

The program memory cell and control logic will support write and row erase operations across the entire VDD range. Bulk Erase is not supported when self-programming.

PIC16(L)F18856/76

10.2 Data EEPROM Memory

Data EEPROM Memory consists of 256 bytes of user data memory. The EEPROM provides storage locations for 8-bit user defined data.

EEPROM can be read and/or written through:

- FSR/INDF indirect access ([Section 10.3 “FSR and INDF Access”](#))
- NVMREG access ([Section 10.4 “NVMREG Access”](#))
- In-Circuit Serial Programming (ICSP)

Unlike PFM, which must be written to by row, EEPROM can be written to word by word.

10.3 FSR and INDF Access

The FSR and INDF registers allow indirect access to the PFM or EEPROM.

10.3.1 FSR READ

With the intended address loaded into an FSR register a `MOVW` instruction or read of INDF will read data from the PFM or EEPROM.

Reading from NVM requires one instruction cycle. The CPU operation is suspended during the read, and resumes immediately after. Read operations return a single word of memory.

10.3.2 FSR WRITE

Writing/erasing the NVM through the FSR registers (ex. `MOVWI` instruction) is not supported in the PIC16(L)F18856/76 devices.

10.4 NVMREG Access

The NVMREG interface allows read/write access to all the locations accessible by FSRs, and also read/write access to the User ID locations, and read-only access to the device identification, revision, and Configuration data.

Reading, writing, or erasing of NVM via the NVMREG interface is prevented when the device is code-protected.

10.4.1 NVMREG READ OPERATION

To read a NVM location using the NVMREG interface, the user must:

1. Clear the NVMREGS bit of the NVMCON1 register if the user intends to access PFM locations, or set NVMREGS if the user intends to access User ID, Configuration, or EEPROM locations.
2. Write the desired address into the NVMADRH:NVMADRL register pair ([Table 10-2](#)).
3. Set the RD bit of the NVMCON1 register to initiate the read.

Once the read control bit is set, the CPU operation is suspended during the read, and resumes immediately after. The data is available in the very next cycle, in the NVMDATH:NVMDATL register pair; therefore, it can be read as two bytes in the following instructions.

NVMDATH:NVMDATL register pair will hold this value until another read or until it is written to by the user.

PIC16(L)F18856/76

Upon completion, the RD bit is cleared by hardware.

FIGURE 10-1: FLASH PROGRAM MEMORY READ FLOWCHART

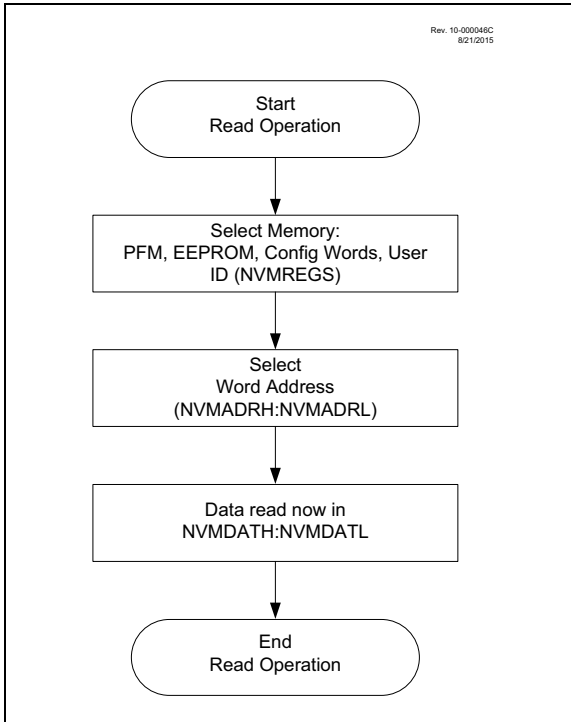

EXAMPLE 10-1: PFM PROGRAM MEMORY READ

```
* This code block will read 1 word of program
* memory at the memory address:
  PROG_ADDR_HI : PROG_ADDR_LO
* data will be returned in the variables:
* PROG_DATA_HI, PROG_DATA_LO

BANKSEL  NVMADRL          ; Select Bank for NVMCON registers
MOVLW   PROG_ADDR_LO     ;
MOVWF   NVMADRL          ; Store LSB of address
MOVLW   PROG_ADDR_HI     ;
MOVWF   NVMADRH          ; Store MSB of address

BCF     NVMCON1,NVMREGS  ; Do not select Configuration Space
BSF     NVMCON1,RD       ; Initiate read

MOVF    NVMDATL,W        ; Get LSB of word
MOVWF   PROG_DATA_LO     ; Store in user location
MOVF    NVMDATH,W        ; Get MSB of word
MOVWF   PROG_DATA_HI     ; Store in user location
```

PIC16(L)F18856/76

10.4.2 NVM UNLOCK SEQUENCE

The unlock sequence is a mechanism that protects the NVM from unintended self-write programming or erasing. The sequence must be executed and completed without interruption to successfully complete any of the following operations:

- PFM Row Erase
- Load of PFM write latches
- Write of PFM write latches to PFM memory
- Write of PFM write latches to User IDs
- Write to EEPROM

The unlock sequence consists of the following steps and must be completed in order:

- Write 55h to NVMCON2
- Write AAh to NVMCON2
- Set the WR bit of NVMCON1

Once the WR bit is set, the processor will stall internal operations until the operation is complete and then resume with the next instruction.

Note: The two NOP instructions after setting the WR bit that were required in previous devices are not required for PIC16(L)F18856/76 devices. See [Figure 10-2](#).

Since the unlock sequence must not be interrupted, global interrupts should be disabled prior to the unlock sequence and re-enabled after the unlock sequence is completed.

FIGURE 10-2: NVM UNLOCK SEQUENCE FLOWCHART

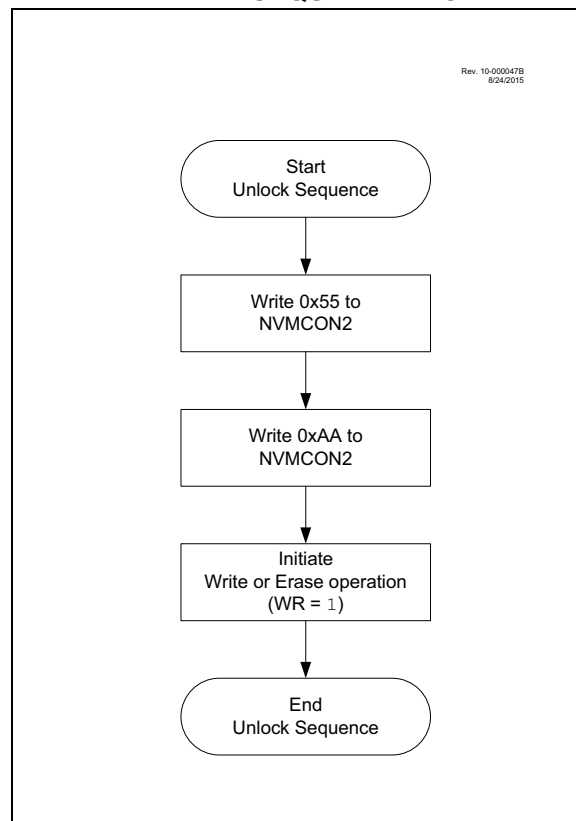

EXAMPLE 10-2: NVM UNLOCK SEQUENCE

```
BCF      INTCON, GIE      ; Recommended so sequence is not interrupted
BANKSEL  NVMCON1         ;
BSF      NVMCON1, WREN    ; Enable write/erase
MOVLW   55h              ; Load 55h

MOVWF   NVMCON2          ; Step 1: Load 55h into NVMCON2
MOVLW   AAh              ; Step 2: Load W with AAh
MOVWF   NVMCON2          ; Step 3: Load AAh into NVMCON2
BSF      NVMCON1, WR      ; Step 4: Set WR bit to begin write/erase
BSF      INTCON, GIE     ; Re-enable interrupts
```

- Note 1:** Sequence begins when NVMCON2 is written; steps 1-4 must occur in the cycle-accurate order shown.
- 2:** Opcodes shown are illustrative; any instruction that has the indicated effect may be used.

PIC16(L)F18856/76

10.4.3 NVMREG WRITE TO EEPROM

Writing to the EEPROM is accomplished by the following steps:

1. Set the NVMREGS and WREN bits of the NVMCON1 register.
2. Write the desired address (address + F000h) into the NVMADRH:NVMADRL register pair (Table 10-2).
3. Perform the unlock sequence as described in Section 10.4.2 “NVM Unlock Sequence”.

A single EEPROM word is written with NVMDATA. The operation includes an implicit erase cycle for that word (it is not necessary to set the FREE bit), and requires many instruction cycles to finish. CPU execution continues in parallel and, when complete, WR is cleared by hardware, NVMIF is set, and an interrupt will occur if NVMIE is also set. Software must poll the WR bit to determine when writing is complete, or wait for the interrupt to occur. WREN will remain unchanged.

Once the EEPROM write operation begins, clearing the WR bit will have no effect; the operation will continue to run to completion.

10.4.4 NVMREG ERASE OF PFM

Before writing to PFM, the word(s) to be written must be erased or previously unwritten. PFM can only be erased one row at a time. No automatic erase occurs upon the initiation of the write to PFM.

To erase a PFM row:

1. Clear the NVMREGS bit of the NVMCON1 register to erase PFM locations, or set the NVMREGS bit to erase User ID locations.
2. Write the desired address into the NVMADRH:NVMADRL register pair (Table 10-2).
3. Set the FREE and WREN bits of the NVMCON1 register.
4. Perform the unlock sequence as described in Section 10.4.2 “NVM Unlock Sequence”.

If the PFM address is write-protected, the WR bit will be cleared and the erase operation will not take place.

While erasing PFM, CPU operation is suspended, and resumes when the operation is complete. Upon completion, the NVMIF is set, and an interrupt will occur if the NVMIE bit is also set.

Write latch data is not affected by erase operations, and WREN will remain unchanged.

FIGURE 10-3: NVM ERASE FLOWCHART

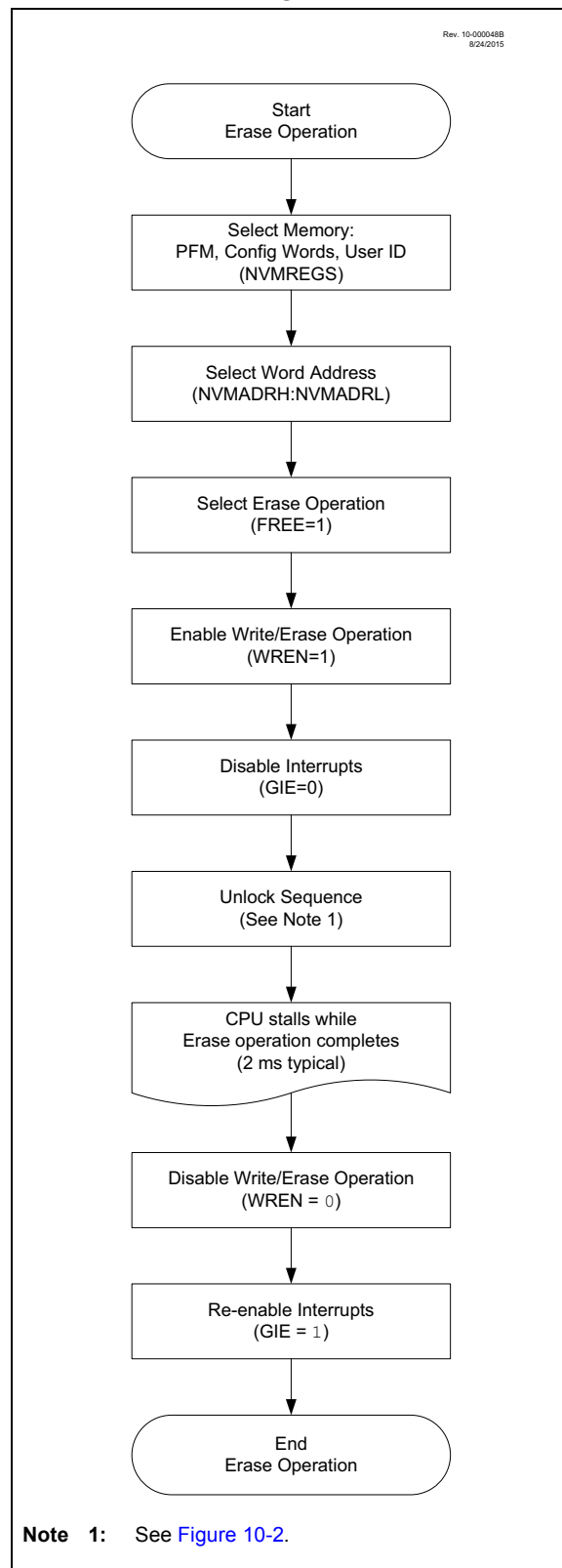

PIC16(L)F18856/76

EXAMPLE 10-3: ERASING ONE ROW OF PROGRAM FLASH MEMORY (PFM)

```

; This sample row erase routine assumes the following:
; 1.A valid address within the erase row is loaded in variables ADDRH:ADDRL
; 2.ADDRH and ADDRL are located in common RAM (locations 0x70 - 0x7F)

BANKSEL      NVMADRL
MOVF         ADDRL,W
MOVWF       NVMADRL          ; Load lower 8 bits of erase address boundary
MOVF         ADDRH,W
MOVWF       NVMADRH        ; Load upper 6 bits of erase address boundary
BCF         NVMCON1,NVMREGS ; Choose PFM memory area
BSF         NVMCON1,FREE    ; Specify an erase operation
BSF         NVMCON1,WREN    ; Enable writes
BCF         INTCON,GIE     ; Disable interrupts during unlock sequence

; -----REQUIRED UNLOCK SEQUENCE:-----

MOVLW       55h            ; Load 55h to get ready for unlock sequence
MOVWF       NVMCON2        ; First step is to load 55h into NVMCON2
MOVLW       AAh            ; Second step is to load AAh into W
MOVWF       NVMCON2        ; Third step is to load AAh into NVMCON2
BSF         NVMCON1,WR     ; Final step is to set WR bit

; -----

BSF         INTCON,GIE     ; Re-enable interrupts, erase is complete
BCF         NVMCON1,WREN   ; Disable writes
    
```

TABLE 10-2: NVM ORGANIZATION AND ACCESS INFORMATION

Master Values			NVMREG Access			FSR Access	
Memory Function	ICSP™ Address	Memory Type	NVMREGS bit (NVMCON1)	NVMADR <15:0>	Allowed Operations	FSR Address	FSR Programming Address
Reset Vector	0000h	PFM	0	8000h	Read Write	8000h	Read-Only
User Memory	0001h		0	8001h		8001h	
	0003h		0	8003h		8003h	
INT Vector	0004h		0	8004h		8004h	
User Memory	0005h		0	8005h		8005h	
	07FFh		0	87FFh		87FFh	
User ID	8000h	PFM	1	8000h	Read	No Access	
	8003h			8003h	Write		
Reserved	8004h	—	—	8004h	—		
Rev ID	8005h	PFM	1	8005h	Read Write		
Device ID	8006h		1	8006h			
CONFIG1	8007h		1	8007h	Read-Only		
CONFIG2	8008h		1	8008h			
CONFIG3	8009h		1	8009h			
CONFIG4	800Ah		1	800Ah			
CONFIG5	800Bh		1	800Bh			
User Memory	F000h	EEPROM	1	F000h	Read Write	7000h	Read-Only
	F0FFh			F0FFh		70FFh	

PIC16(L)F18856/76

10.4.5 NVMREG WRITE TO PFM

Program memory is programmed using the following steps:

1. Load the address of the row to be programmed into NVMADRH:NVMADRL.
2. Load each write latch with data.
3. Initiate a programming operation.
4. Repeat steps 1 through 3 until all data is written.

Before writing to program memory, the word(s) to be written must be erased or previously unwritten. Program memory can only be erased one row at a time. No automatic erase occurs upon the initiation of the write.

Program memory can be written one or more words at a time. The maximum number of words written at one time is equal to the number of write latches. See [Figure 10-4](#) (row writes to program memory with 32 write latches) for more details.

The write latches are aligned to the Flash row address boundary defined by the upper ten bits of NVMADRH:NVMADRL, (NVMADRH<6:0>:NVMADRL<7:5>) with the lower five bits of NVMADRL, (NVMADRL<4:0>) determining the write latch being loaded. Write operations do not cross these boundaries. At the completion of a program memory write operation, the data in the write latches is reset to contain 0x3FFF.

The following steps should be completed to load the write latches and program a row of program memory. These steps are divided into two parts. First, each write latch is loaded with data from the NVMDATH:NVMDATL using the unlock sequence with LWLO = 1. When the last word to be loaded into the write latch is ready, the LWLO bit is cleared and the unlock sequence executed. This initiates the programming operation, writing all the latches into Flash program memory.

Note: The special unlock sequence is required to load a write latch with data or initiate a Flash programming operation. If the unlock sequence is interrupted, writing to the latches or program memory will not be initiated.

1. Set the WREN bit of the NVMCON1 register.
2. Clear the NVMREGS bit of the NVMCON1 register.
3. Set the LWLO bit of the NVMCON1 register. When the LWLO bit of the NVMCON1 register is '1', the write sequence will only load the write latches and will not initiate the write to Flash program memory.
4. Load the NVMADRH:NVMADRL register pair with the address of the location to be written.
5. Load the NVMDATH:NVMDATL register pair with the program memory data to be written.
6. Execute the unlock sequence ([Section 10.4.2 "NVM Unlock Sequence"](#)). The write latch is now loaded.
7. Increment the NVMADRH:NVMADRL register pair to point to the next location.
8. Repeat steps 5 through 7 until all but the last write latch has been loaded.
9. Clear the LWLO bit of the NVMCON1 register. When the LWLO bit of the NVMCON1 register is '0', the write sequence will initiate the write to Flash program memory.
10. Load the NVMDATH:NVMDATL register pair with the program memory data to be written.
11. Execute the unlock sequence ([Section 10.4.2 "NVM Unlock Sequence"](#)). The entire program memory latch content is now written to Flash program memory.

Note: The program memory write latches are reset to the blank state (0x3FFF) at the completion of every write or erase operation. As a result, it is not necessary to load all the program memory write latches. Unloaded latches will remain in the blank state.

An example of the complete write sequence is shown in [Example 10-4](#). The initial address is loaded into the NVMADRH:NVMADRL register pair; the data is loaded using indirect addressing.

FIGURE 10-4: BLOCK WRITES TO PROGRAM FLASH MEMORY (PFM) WITH 32 WRITE LATCHES

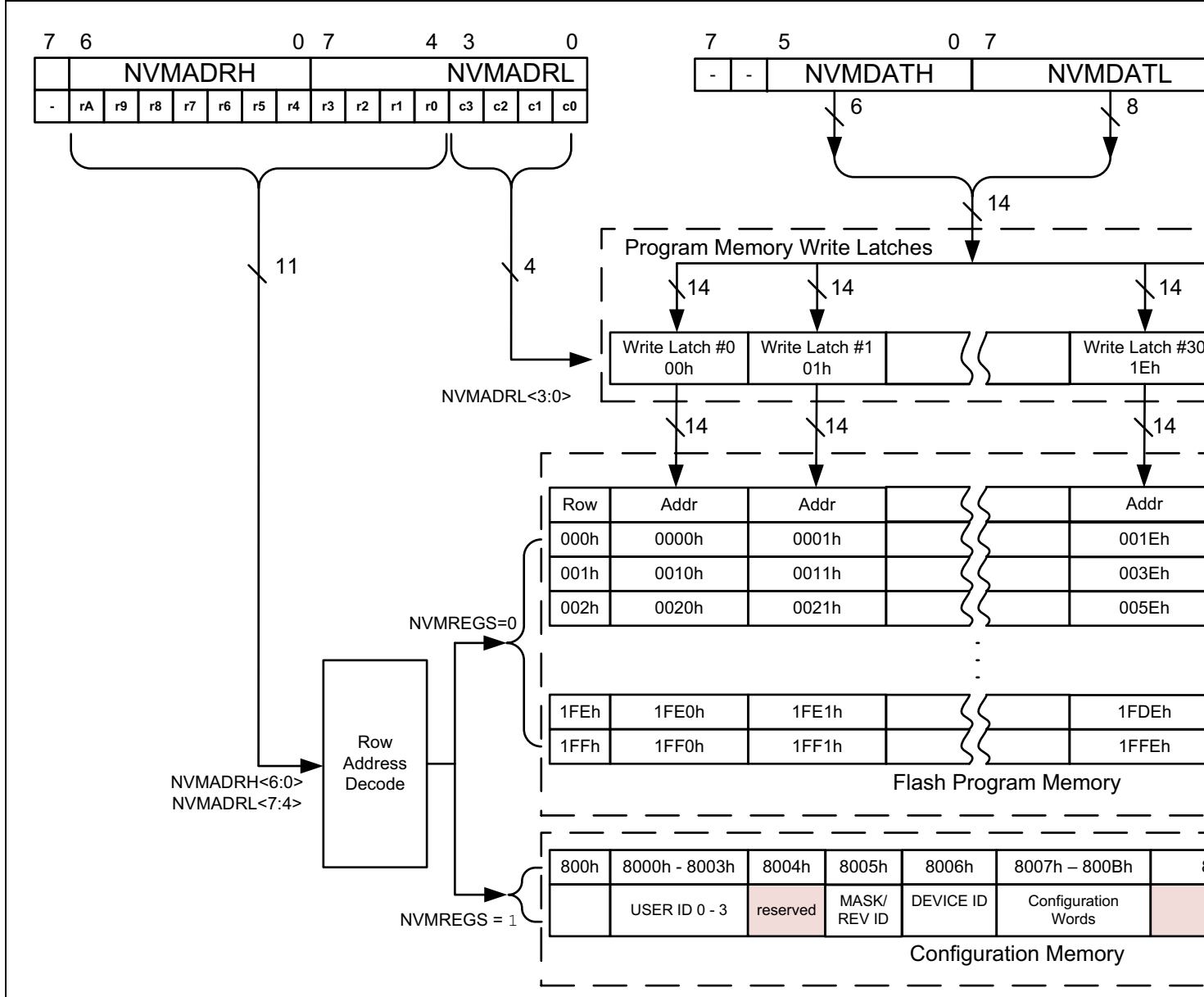

PIC16(L)F18856/76

FIGURE 10-5: PROGRAM FLASH MEMORY (PFM) WRITE FLOWCHART

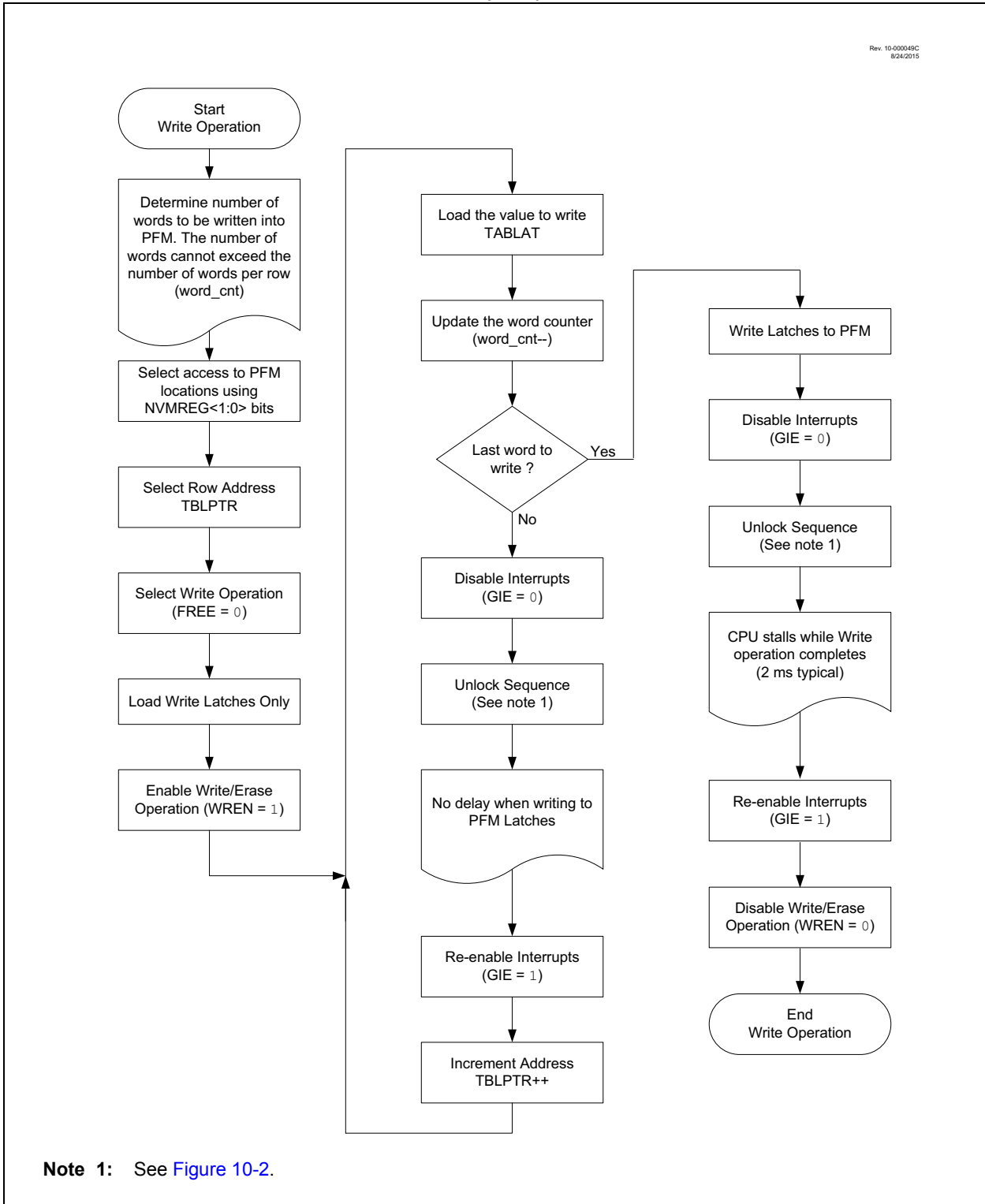

PIC16(L)F18856/76

EXAMPLE 10-4: WRITING TO PROGRAM FLASH MEMORY (PFM)

```
; This write routine assumes the following:
; 1. 64 bytes of data are loaded, starting at the address in DATA_ADDR
; 2. Each word of data to be written is made up of two adjacent bytes in DATA_ADDR,
;    stored in little endian format
; 3. A valid starting address (the least significant bits = 00000) is loaded in ADDRH:ADDRL
; 4. ADDRH and ADDRL are located in common RAM (locations 0x70 - 0x7F)
; 5. NVM interrupts are not taken into account

        BANKSEL      NVMADRH
        MOVF          ADDRH,W
        MOVWF         NVMADRH           ; Load initial address
        MOVF          ADDRL,W
        MOVWF         NVMADRL
        MOVLW        LOW DATA_ADDR    ; Load initial data address
        MOVWF         FSR0L
        MOVLW        HIGH DATA_ADDR
        MOVWF         FSR0H
        BCF          NVMCON1,NVMREGS   ; Set Program Flash Memory as write location
        BSF          NVMCON1,WREN      ; Enable writes
        BSF          NVMCON1,LWLO     ; Load only write latches

LOOP
        MOVIW        FSR0++
        MOVWF         NVMDATL         ; Load first data byte
        MOVIW        FSR0++
        MOVWF         NVMDATH         ; Load second data byte

        MOVF          NVMADRL,W
        XORLW        0x1F             ; Check if lower bits of address are 00000
        ANDLW        0x1F             ; and if on last of 32 addresses
        BTFSCL       STATUS,Z         ; Last of 32 words?
        GOTO         START_WRITE      ; If so, go write latches into memory

        CALL         UNLOCK_SEQ       ; If not, go load latch
        INCF         NVMADRL,F        ; Increment address
        GOTO         LOOP

START_WRITE
        BCF          NVMCON1,LWLO     ; Latch writes complete, now write memory
        CALL         UNLOCK_SEQ       ; Perform required unlock sequence
        BCF          NVMCON1,WREN     ; Disable writes

UNLOCK_SEQ
        MOVLW        55h
        BCF          INTCON,GIE       ; Disable interrupts
        MOVWF         NVMCON2         ; Begin unlock sequence
        MOVLW        AAh
        MOVWF         NVMCON2
        BSF          NVMCON1,WR
        BSF          INTCON,GIE       ; Unlock sequence complete, re-enable interrupts
return
```

PIC16(L)F18856/76

10.4.6 MODIFYING FLASH PROGRAM MEMORY

When modifying existing data in a program memory row, and data within that row must be preserved, it must first be read and saved in a RAM image. Program memory is modified using the following steps:

1. Load the starting address of the row to be modified.
2. Read the existing data from the row into a RAM image.
3. Modify the RAM image to contain the new data to be written into program memory.
4. Load the starting address of the row to be rewritten.
5. Erase the program memory row.
6. Load the write latches with data from the RAM image.
7. Initiate a programming operation.

FIGURE 10-6: FLASH PROGRAM MEMORY MODIFY FLOWCHART

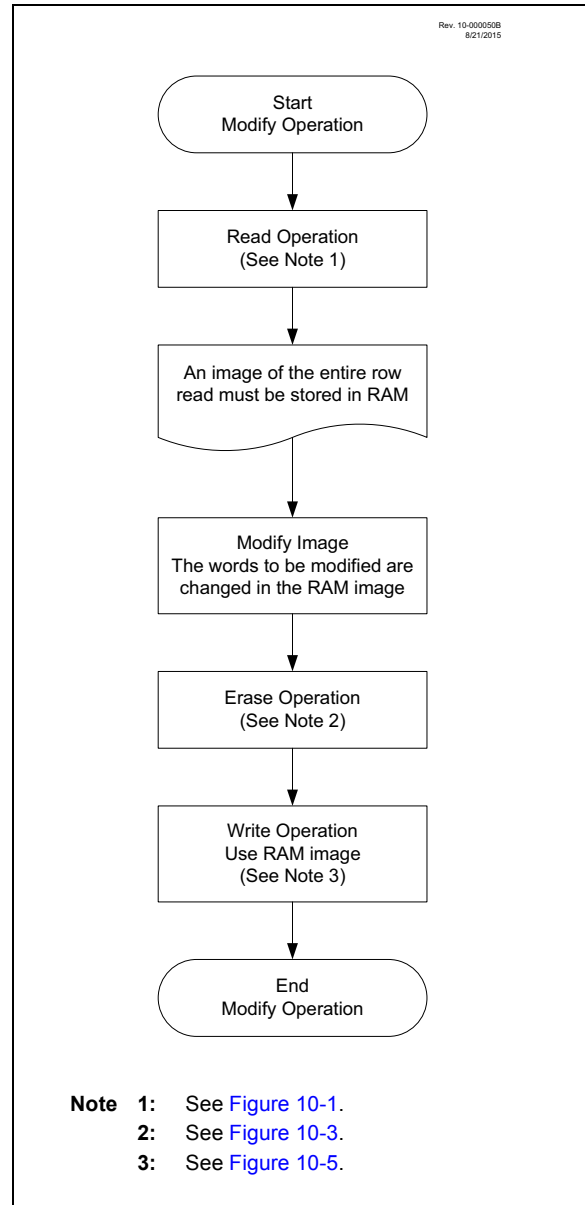

PIC16(L)F18856/76

10.4.7 NVMREG DATA EEPROM MEMORY, USER ID, DEVICE ID AND CONFIGURATION WORD ACCESS

Instead of accessing Program Flash Memory (PFM), the Data EEPROM Memory, the User ID's, Device ID/Revision ID and Configuration Words can be accessed when NVMREGS = 1 in the NVMCON1 register. This is the region that would be pointed to by PC<15> = 1, but not all addresses are accessible. Different access may exist for reads and writes. Refer to [Table 10-3](#).

When read access is initiated on an address outside the parameters listed in [Table 10-3](#), the NVMDATH: NVMDATL register pair is cleared, reading back '0's.

FIGURE 10-7: FLASH PROGRAM MEMORY MODIFY FLOWCHART

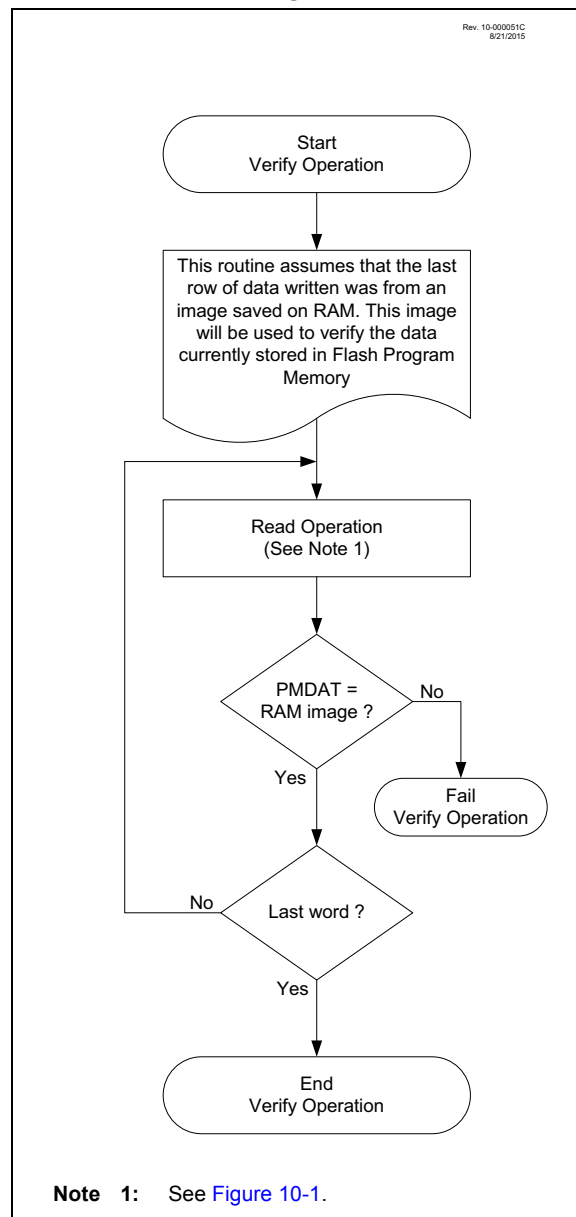

TABLE 10-3: EEPROM, USER ID, DEV/REV ID AND CONFIGURATION WORD ACCESS (NVMREGS = 1)

Address	Function	Read Access	Write Access
8000h-8003h	User IDs	Yes	Yes
8005h-8006h	Device ID/Revision ID	Yes	No
8007h-800Bh	Configuration Words 1-5	Yes	No
F000h-F0FFh	EEPROM	Yes	Yes

PIC16(L)F18856/76

EXAMPLE 10-5: DEVICE ID ACCESS

```
; This write routine assumes the following:
; 1. 64 bytes of data are loaded, starting at the address in DATA_ADDR
; 2. Each word of data to be written is made up of two adjacent bytes in DATA_ADDR,
;    stored in little endian format
; 3. A valid starting address (the least significant bits = 00000) is loaded in ADDRH:ADDRL
; 4. ADDRH and ADDRL are located in common RAM (locations 0x70 - 0x7F)
; 5. NVM interrupts are not taken into account

        BANKSEL          NVMADRH
        MOVF             ADDRH,W
        MOVWF           NVMADRH           ; Load initial address
        MOVF             ADDRL,W
        MOVWF           NVMADRL
        MOVLW           LOW DATA_ADDR   ; Load initial data address
        MOVWF           FSR0L
        MOVLW           HIGH DATA_ADDR
        MOVWF           FSR0H
        BCF             NVMCON1,NVMREGS  ; Set PFM as write location
        BSF             NVMCON1,WREN     ; Enable writes
        BSF             NVMCON1,LWLO     ; Load only write latches

LOOP
        MOVIW           FSR0++
        MOVWF           NVMDATL         ; Load first data byte
        MOVIW           FSR0++
        MOVWF           NVMDATAH       ; Load second data byte
        MOVF            NVMADRL,W
        XORLW           0x1F            ; Check if lower bits of address are 00000
        ANDLW           0x1F            ; and if on last of 32 addresses
        BTFSCL          STATUS,Z        ; Last of 32 words?
        GOTO            START_WRITE     ; If so, go write latches into memory

        CALL            UNLOCK_SEQ      ; If not, go load latch
        INCF            NVMADRL,F       ; Increment address
        GOTO            LOOP

START_WRITE
        BCF             NVMCON1,LWLO     ; Latch writes complete, now write memory
        CALL            UNLOCK_SEQ      ; Perform required unlock sequence
        BSF             NVMCON1,WREN     ; Disable writes

UNLOCK_SEQ
        MOVLW           55h
        BCF             INTCON,GIE      ; Disable interrupts
        MOVWF           NVMCON2         ; Begin unlock sequence
        MOVLW           AAh
        MOVWF           NVMCON2
        BSF             NVMCON1,WR
        BSF             INTCON,GIE      ; Unlock sequence complete, re-enable interrupts
        return
```

PIC16(L)F18856/76

10.4.8 WRITE VERIFY

It is considered good programming practice to verify that program memory writes agree with the intended value. Since program memory is stored as a full page then the stored program memory contents are compared with the intended data stored in RAM after the last write is complete.

FIGURE 10-8: FLASH PROGRAM MEMORY VERIFY FLOWCHART

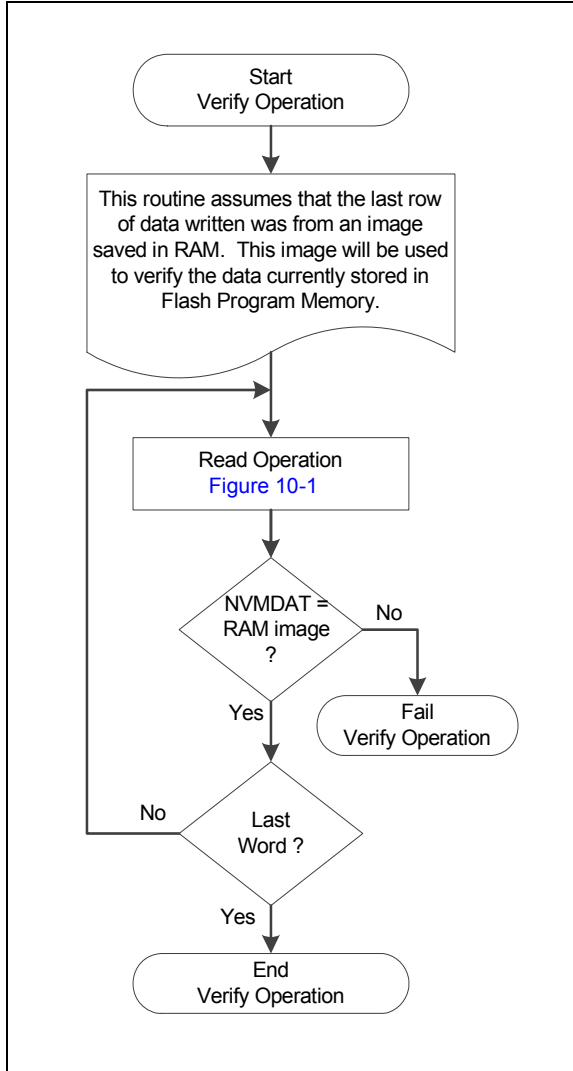

PIC16(L)F18856/76

10.4.9 WRERR BIT

The WRERR bit can be used to determine if a write error occurred.

WRERR will be set if one of the following conditions occurs:

- If WR is set while the NVMADRH:NMVADRL points to a write-protected address
- A Reset occurs while a self-write operation was in progress
- An unlock sequence was interrupted

The WRERR bit is normally set by hardware, but can be set by the user for test purposes. Once set, WRERR must be cleared in software.

TABLE 10-4: ACTIONS FOR PFM WHEN WR = 1

Free	LWLO	Actions for PFM when WR = 1	Comments
1	x	Erase the 32-word row of NVMADRH:NMVADRL location. See Section 10.4.3 “NVMREG Write to EEPROM”	<ul style="list-style-type: none">• If WP is enabled, WR is cleared and WRERR is set• All 32 words are erased• NVMDATH:NVMDATL is ignored
0	1	Copy NVMDATH:NVMDATL to the write latch corresponding to NVMADR LSBs. See Section 10.4.4 “NVMREG Erase of PFM”	<ul style="list-style-type: none">• Write protection is ignored• No memory access occurs
0	0	Write the write-latch data to PFM row. See Section 10.4.4 “NVMREG Erase of PFM”	<ul style="list-style-type: none">• If WP is enabled, WR is cleared and WRERR is set• Write latches are reset to 3FFh• NVMDATH:NVMDATL is ignored

PIC16(L)F18856/76

10.5 Register Definitions: Flash Program Memory Control

REGISTER 10-1: NVMDATL: NONVOLATILE MEMORY DATA LOW BYTE REGISTER

R/W-x/u	R/W-x/u	R/W-x/u	R/W-x/u	R/W-x/u	R/W-x/u	R/W-x/u	R/W-x/u
NVMDAT<7:0>							
bit 7							bit 0

Legend:

R = Readable bit W = Writable bit U = Unimplemented bit, read as '0'
u = Bit is unchanged x = Bit is unknown -n/n = Value at POR and BOR/Value at all other Resets
'1' = Bit is set '0' = Bit is cleared

bit 7-0 **NVMDAT<7:0>**: Read/write value for Least Significant bits of program memory

REGISTER 10-2: NVMDATH: NONVOLATILE MEMORY DATA HIGH BYTE REGISTER

U-0	U-0	R/W-x/u	R/W-x/u	R/W-x/u	R/W-x/u	R/W-x/u	R/W-x/u
—		NVMDAT<13:8>					
bit 7							bit 0

Legend:

R = Readable bit W = Writable bit U = Unimplemented bit, read as '0'
u = Bit is unchanged x = Bit is unknown -n/n = Value at POR and BOR/Value at all other Resets
'1' = Bit is set '0' = Bit is cleared

bit 7-6 **Unimplemented**: Read as '0'

bit 5-0 **NVMDAT<13:8>**: Read/write value for Most Significant bits of program memory

REGISTER 10-3: NVMAADR: NONVOLATILE MEMORY ADDRESS LOW BYTE REGISTER

R/W-0/0	R/W-0/0	R/W-0/0	R/W-0/0	R/W-0/0	R/W-0/0	R/W-0/0	R/W-0/0
NVMAADR<7:0>							
bit 7							bit 0

Legend:

R = Readable bit W = Writable bit U = Unimplemented bit, read as '0'
u = Bit is unchanged x = Bit is unknown -n/n = Value at POR and BOR/Value at all other Resets
'1' = Bit is set '0' = Bit is cleared

bit 7-0 **NVMAADR<7:0>**: Specifies the Least Significant bits for program memory address

REGISTER 10-4: NVMAADR: NONVOLATILE MEMORY ADDRESS HIGH BYTE REGISTER

U-1	R/W-0/0	R/W-0/0	R/W-0/0	R/W-0/0	R/W-0/0	R/W-0/0	R/W-0/0
—(1)	NVMAADR<14:8>						
bit 7							bit 0

Legend:

R = Readable bit W = Writable bit U = Unimplemented bit, read as '0'
u = Bit is unchanged x = Bit is unknown -n/n = Value at POR and BOR/Value at all other Resets
'1' = Bit is set '0' = Bit is cleared

bit 7 **Unimplemented**: Read as '1'

bit 6-0 **NVMAADR<14:8>**: Specifies the Most Significant bits for program memory address

Note 1: Bit is undefined while WR = 1 (during the EEPROM write operation it may be '0' or '1').

PIC16(L)F18856/76

REGISTER 10-5: NVMCON1: NONVOLATILE MEMORY CONTROL 1 REGISTER

U-0	R/W-0/0	R/W-0/0	R/W/HC-0/0	R/W/HC-x/q	R/W-0/0	R/S/HC-0/0	R/S/HC-0/0
—	NVMREGS	LWLO	FREE	WRERR ^(1,2,3)	WREN	WR ^(4,5,6)	RD ⁽⁷⁾
bit 7							bit 0

Legend:

R = Readable bit	W = Writable bit	U = Unimplemented bit, read as '0'
S = Bit can only be set	x = Bit is unknown	-n/n = Value at POR and BOR/Value at all other Resets
'1' = Bit is set	'0' = Bit is cleared	HC = Bit is cleared by hardware

bit 7	Unimplemented: Read as '0'
bit 6	NVMREGS: Configuration Select bit 1 = Access EEPROM, Configuration, User ID and Device ID Registers 0 = Access PFM
bit 5	LWLO: Load Write Latches Only bit <u>When FREE = 0:</u> 1 = The next WR command updates the write latch for this word within the row; no memory operation is initiated. 0 = The next WR command writes data or erases Otherwise: The bit is ignored
bit 4	FREE: PFM Erase Enable bit <u>When NVMREGS:NVMADR points to a PFM location:</u> 1 = Performs an erase operation with the next WR command; the 32-word pseudo-row containing the indicated address is erased (to all 1s) to prepare for writing. 0 = All write operations have completed normally
bit 3	WRERR: Program/Erase Error Flag bit ^(1,2,3) This bit is normally set by hardware. 1 = A write operation was interrupted by a Reset, interrupted unlock sequence, or WR was written to one while NVMADR points to a write-protected address. 0 = The program or erase operation completed normally
bit 2	WREN: Program/Erase Enable bit 1 = Allows program/erase cycles 0 = Inhibits programming/erasing of program Flash
bit 1	WR: Write Control bit ^(4,5,6) <u>When NVMREG:NVMADR points to a EEPROM location:</u> 1 = Initiates an erase/program cycle at the corresponding EEPROM location 0 = NVM program/erase operation is complete and inactive <u>When NVMREG:NVMADR points to a PFM location:</u> 1 = Initiates the operation indicated by Table 10-4 0 = NVM program/erase operation is complete and inactive Otherwise: This bit is ignored
bit 0	RD: Read Control bit ⁽⁷⁾ 1 = Initiates a read at address = NVMADR1, and loads data to NVMDAT. Read takes one instruction cycle and the bit is cleared when the operation is complete. The bit can only be set (not cleared) in software. 0 = NVM read operation is complete and inactive

- Note**
- 1: Bit is undefined while WR = 1 (during the EEPROM write operation it may be '0' or '1').
 - 2: Bit must be cleared by software; hardware will not clear this bit.
 - 3: Bit may be written to '1' by software in order to implement test sequences.
 - 4: This bit can only be set by following the unlock sequence of [Section 10.4.2 "NVM Unlock Sequence"](#).
 - 5: Operations are self-timed, and the WR bit is cleared by hardware when complete.
 - 6: Once a write operation is initiated, setting this bit to zero will have no effect.
 - 7: Reading from EEPROM loads only NVMDATL<7:0> ([Register 10-1](#)).

PIC16(L)F18856/76

REGISTER 10-6: NVMCON2: NONVOLATILE MEMORY CONTROL 2 REGISTER

W-0/0	W-0/0	W-0/0	W-0/0	W-0/0	W-0/0	W-0/0	W-0/0
NVMCON2<7:0>							
bit 7							
bit 0							

Legend:

R = Readable bit	W = Writable bit	U = Unimplemented bit, read as '0'
S = Bit can only be set	x = Bit is unknown	-n/n = Value at POR and BOR/Value at all other Resets
'1' = Bit is set	'0' = Bit is cleared	

bit 7-0 **NVMCON2<7:0>**: Flash Memory Unlock Pattern bits
 To unlock writes, a 55h must be written first, followed by an AAh, before setting the WR bit of the NVMCON1 register. The value written to this register is used to unlock the writes.

TABLE 10-5: SUMMARY OF REGISTERS ASSOCIATED WITH NONVOLATILE MEMORY (NVM)

Name	Bit 7	Bit 6	Bit 5	Bit 4	Bit 3	Bit 2	Bit 1	Bit 0	Register on Page
INTCON	GIE	PEIE	—	—	—	—	—	INTEDG	134
PIE7	SCANIE	CRCIE	NVMIE	NCO1IE	—	CWG3IE	CWG2IE	CWG1IE	137
PIR7	SCANIF	CRCIF	NVMIF	NCO1IF	—	CWG3IF	CWG2IF	CWG1IF	146
NVMCON1	—	NVMREGS	LWLO	FREE	WRERR	WREN	WR	RD	186
NVMCON2	NVMCON2<7:0>								187
NVMADRL	NVMADR<7:0>								185
NVMADRH	— ⁽¹⁾	NVMADR<14:8>							185
NVMDATL	NVMDAT<7:0>								185
NVMDATH	—	—	NVMDAT<13:8>					185	

Legend: — = unimplemented location, read as '0'. Shaded cells are not used by NVM.

Note 1: Unimplemented, read as '1'.

PIC16(L)F18856/76

11.0 CYCLIC REDUNDANCY CHECK (CRC) MODULE

The Cyclic Redundancy Check (CRC) module provides a software-configurable hardware-implemented CRC checksum generator. This module includes the following features:

- Any standard CRC up to 16 bits can be used
- Configurable Polynomial
- Any seed value up to 16 bits can be used
- Standard and reversed bit order available
- Augmented zeros can be added automatically or by the user
- Memory scanner for fast CRC calculations on program memory user data
- Software loadable data registers for calculating CRC values not from the memory scanner

11.1 CRC Module Overview

The CRC module provides a means for calculating a check value of program memory. The CRC module is coupled with a memory scanner for faster CRC calculations. The memory scanner can automatically provide data to the CRC module. The CRC module can also be operated by directly writing data to SFRs, without using the scanner.

11.2 CRC Functional Overview

The CRC module can be used to detect bit errors in the Flash memory using the built-in memory scanner or through user input RAM memory. The CRC module can accept up to a 16-bit polynomial with up to a 16-bit seed value. A CRC calculated check value (or checksum) will then be generated into the CRCACC<15:0> registers for user storage. The CRC module uses an XOR shift register implementation to perform the polynomial division required for the CRC calculation.

EXAMPLE 11-1: BASIC CRC OPERATION EXAMPLE

```
CRC-16-ANSI
 $x^{16} + x^{15} + x^2 + 1$  (17 bits)
Standard 16-bit representation = 0x8005

CRCXORH = 0b10000000
CRCXORL = 0b0000010- (1)

Data Sequence:
0x55, 0x66, 0x77, 0x88
DLEN = 0b0111
PLEN = 0b1111

Data entered into the CRC:
SHIFTM = 0:
01010101 01100110 01110111 10001000

SHIFTM = 1:
10101010 01100110 11101110 00010001

Check Value (ACCM = 1):
SHIFTM = 0: 0x32D6
CRCACCH = 0b00110010
CRCACCL = 0b11010110

SHIFTM = 1: 0x6BA2
CRCACCH = 0b01101011
CRCACCL = 0b10100010
```

Note 1: Bit 0 is unimplemented. The LSb of any CRC polynomial is always '1' and will always be treated as a '1' by the CRC for calculating the CRC check value. This bit will be read in software as a '0'.

11.3 CRC Polynomial Implementation

Any standard polynomial up to 17 bits can be used. The PLEN<3:0> bits are used to specify how long the polynomial used will be. For an x^n polynomial, PLEN = n-2. In an n-bit polynomial the x^n bit and the LSb will be used as a '1' in the CRC calculation because the MSb and LSb must always be a '1' for a CRC polynomial. For example, if using CRC-16-ANSI, the polynomial will look like 0x8005. This will be implemented into the CRCXOR<15:1> registers, as shown in [Example 11-1](#).

PIC16(L)F18856/76

FIGURE 11-1: CRC LFSR EXAMPLE

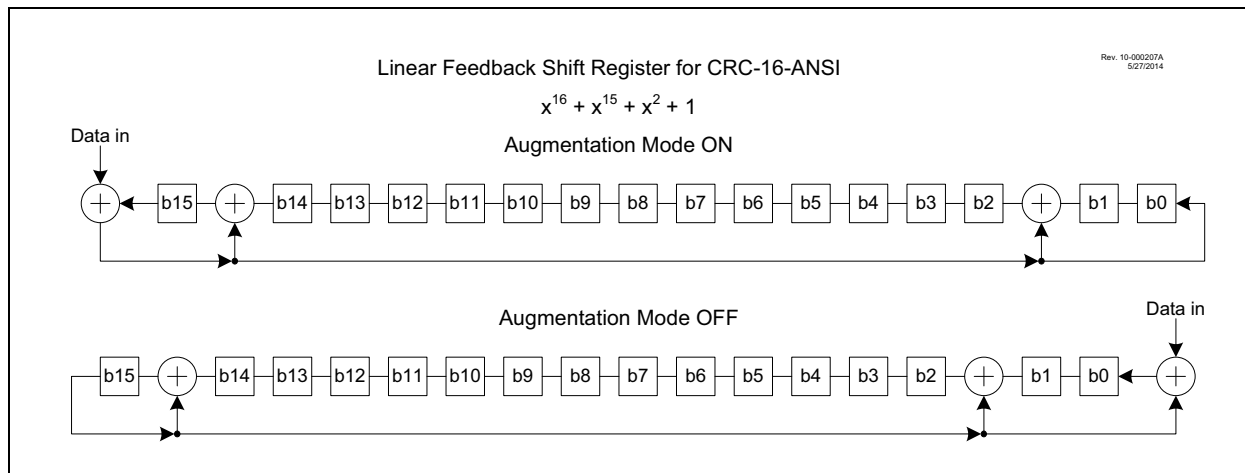

11.4 CRC Data Sources

Data can be input to the CRC module in two ways:

- User data using the CRCDAT registers
- Flash using the Program Memory Scanner

To set the number of bits of data, up to 16 bits, the DLEN bits of CRCCON1 must be set accordingly. Only data bits in CRCDATA registers up to DLEN will be used, other data bits in CRCDATA registers will be ignored.

Data is moved into the CRCSHIFT as an intermediate to calculate the check value located in the CRCACC registers.

The SHIFTM bit is used to determine the bit order of the data being shifted into the accumulator. If SHIFTM is not set, the data will be shifted in MSb first. The value of DLEN will determine the MSb. If SHIFTM bit is set, the data will be shifted into the accumulator in reversed order, LSb first.

The CRC module can be seeded with an initial value by setting the CRCACC<15:0> registers to the appropriate value before beginning the CRC.

11.4.1 CRC FROM USER DATA

To use the CRC module on data input from the user, the user must write the data to the CRCDAT registers. The data from the CRCDAT registers will be latched into the shift registers on any write to the CRCDATL register.

11.4.2 CRC FROM FLASH

To use the CRC module on data located in Flash memory, the user can initialize the Program Memory Scanner as defined in [Section 11.8, Program Memory Scan Configuration](#).

11.5 CRC Check Value

The CRC check value will be located in the CRCACC registers after the CRC calculation has finished. The check value will depend on two mode settings of the CRCCON: ACCM and SHIFTM.

If the ACCM bit is set, the CRC module will augment the data with a number of zeros equal to the length of the polynomial to find the final check value. If the ACCM bit is not set, the CRC will stop at the end of the data. A number of zeros equal to the length of the polynomial can then be entered to find the same check value as augmented mode, alternatively the expected check value can be entered at this point to make the final result equal to 0.

A final XOR value may be needed with the check value to find the desired CRC result

11.6 CRC Interrupt

The CRC will generate an interrupt when the BUSY bit transitions from '1' to '0'. The CRCIF interrupt flag bit of the PIR6 register is set every time the BUSY bit transitions, regardless of whether or not the CRC interrupt is enabled. The CRCIF bit can only be cleared in software. The CRC interrupt enable is the CRCIE bit of the PIE6 register.

11.7 Configuring the CRC

The following steps illustrate how to properly configure the CRC.

1. Determine if the automatic Program Memory scan will be used with the scanner or manual calculation through the SFR interface and perform the actions specified in [Section 11.4 “CRC Data Sources”](#), depending on which decision was made.
2. If desired, seed a starting CRC value into the CRCACCH/L registers.
3. Program the CRCXORH/L registers with the desired generator polynomial.
4. Program the DLEN<3:0> bits of the CRCCON1 register with the length of the data word – 1 (refer to [Example 11-1](#)). This determines how many times the shifter will shift into the accumulator for each data word.
5. Program the PLEN<3:0> bits of the CRCCON1 register with the length of the polynomial – 2 (refer to [Example 11-1](#)).
6. Determine whether shifting in trailing zeros is desired and set the ACCM bit of CRCCON0 register appropriately.
7. Likewise, determine whether the MSb or LSb should be shifted first and write the SHIFTM bit of CRCCON0 register appropriately.
8. Write the CRCGO bit of the CRCCON0 register to begin the shifting process.
- 9a. If manual SFR entry is used, monitor the FULL bit of CRCCON0 register. When FULL = 0, another word of data can be written to the CRCDATH/L registers, keeping in mind that CRCDATH should be written first if the data has >8 bits, as the shifter will begin upon the CRCDATL register being written.
- 9b. If the scanner is used, the scanner will automatically stuff words into the CRCDATH/L registers as needed, as long as the SCANGO bit is set.
- 10a. If using the Flash memory scanner, monitor the SCANIF (or the SCANGO bit) for the scanner to finish pushing information into the CRCDATA registers. After the scanner is completed, monitor the CRCIF (or the BUSY bit) to determine that the CRC has been completed and the check value can be read from the CRCACC registers. If both the interrupt flags are set (or both BUSY and SCANGO bits are cleared), the completed CRC calculation can be read from the CRCACCH/L registers.
- 10b. If manual entry is used, monitor the CRCIF (or BUSY bit) to determine when the CRCACC registers will hold the check value.

11.8 Program Memory Scan Configuration

If desired, the Program Memory Scan module may be used in conjunction with the CRC module to perform a CRC calculation over a range of program memory addresses. In order to set up the Scanner to work with the CRC you need to perform the following steps:

1. Set the EN bit to enable the module. This can be performed at any point preceding the setting of the SCANGO bit, but if it gets disabled, all internal states of the Scanner are reset (registers are unaffected).
2. Choose which memory access mode is to be used (see [Section 11.10 “Scanning Modes”](#)) and set the MODE bits of the SCANCON0 register appropriately.
3. Based on the memory access mode, set the INTM bits of the SCANCON0 register to the appropriate interrupt mode (see [Section 11.10.5 “Interrupt Interaction”](#)).
4. Set the SCANLADRL/H and SCANHADRL/H registers with the beginning and ending locations in memory that are to be scanned.
5. Begin the scan by setting the SCANGO bit in the SCANCON0 register. The scanner will wait (CRCGO must be set) for the signal from the CRC that it is ready for the first Flash memory location, then begin loading data into the CRC. It will continue to do so until it either hits the configured end address or an address that is unimplemented on the device, at which point the SCANGO bit will clear, Scanner functions will cease, and the SCANIF interrupt will be triggered. Alternately, the SCANGO bit can be cleared in software if desired.

11.9 Scanner Interrupt

The scanner will trigger an interrupt when the SCANGO bit transitions from ‘1’ to ‘0’. The SCANIF interrupt flag of PIR7 is set when the last memory location is reached and the data is entered into the CRCDATA registers. The SCANIF bit can only be cleared in software. The SCAN interrupt enable is the SCANIE bit of the PIE7 register.

11.10 Scanning Modes

The memory scanner can scan in four modes: Burst, Peek, Concurrent, and Triggered. These modes are controlled by the MODE bits of the SCANCON0 register. The four modes are summarized in [Table 11-1](#).

PIC16(L)F18856/76

11.10.1 BURST MODE

When MODE = 01, the scanner is in Burst mode. In Burst mode, CPU operation is stalled beginning with the operation after the one that sets the SCANGO bit, and the scan begins, using the instruction clock to execute. The CPU is held until the scan stops. Note that because the CPU is not executing instructions, the SCANGO bit cannot be cleared in software, so the CPU will remain stalled until one of the hardware end-conditions occurs. Burst mode has the highest throughput for the scanner, but has the cost of stalling other execution while it occurs.

11.10.2 CONCURRENT MODE

When MODE = 00, the scanner is in Concurrent mode. Concurrent mode, like Burst mode, stalls the CPU while performing accesses of memory. However, while Burst mode stalls until all accesses are complete, Concurrent mode allows the CPU to execute in between access cycles.

11.10.3 TRIGGERED MODE

When MODE = 11, the scanner is in Triggered mode. Triggered mode behaves identically to Concurrent mode, except instead of beginning the scan immediately upon the SCANGO bit being set, it waits for a rising edge from a separate trigger clock, the source of which is determined by the SCANTRIG register.

11.10.4 PEEK MODE

When MODE = 10, the scanner is in Peek mode. Peek mode waits for an instruction cycle in which the CPU does not need to access the NVM (such as a branch instruction) and uses that cycle to do its own NVM access. This results in the lowest throughput for the NVM access (and can take a much longer time to complete a scan than the other modes), but does so without any impact on execution times, unlike the other modes.

TABLE 11-1: SUMMARY OF SCANNER MODES

MODE<1:0>		Description		
		First Scan Access	CPU Operation	
11	Triggered	As soon as possible following a trigger	Stalled during NVM access	CPU resumes execution following each access
10	Peek	At the first dead cycle	Timing is unaffected	CPU continues execution following each access
01	Burst	As soon as possible	Stalled during NVM access	CPU suspended until scan completes
00	Concurrent			CPU resumes execution following each access

11.10.5 INTERRUPT INTERACTION

The INTM bit of the SCANCON0 register controls the scanner's response to interrupts depending on which mode the NVM scanner is in, as described in [Table 11-2](#).

TABLE 11-2: SCAN INTERRUPT MODES

INTM	MODE<1:0>	
	MODE == Burst	MODE != Burst
1	Interrupt overrides SCANGO to pause the burst and the interrupt handler executes at full speed; Scanner Burst resumes when interrupt completes.	Scanner suspended during interrupt response; interrupt executes at full speed and scan resumes when the interrupt is complete.
0	Interrupts do not override SCANGO, and the scan (burst) operation will continue; interrupt response will be delayed until scan completes (latency will be increased).	Scanner accesses NVM during interrupt response. If MODE != Peak the interrupt handler execution speed will be affected.

PIC16(L)F18856/76

In general, if $INTM = 0$, the scanner will take precedence over the interrupt, resulting in decreased interrupt processing speed and/or increased interrupt response latency. If $INTM = 1$, the interrupt will take precedence and have a better speed, delaying the memory scan.

11.10.6 WDT INTERACTION

Operation of the WDT is not affected by scanner activity. Hence, it is possible that long scans, particularly in Burst mode, may exceed the WDT time-out period and result in an undesired device Reset. This should be considered when performing memory scans with an application that also utilizes WDT.

11.10.7 IN-CIRCUIT DEBUG (ICD) INTERACTION

The scanner freezes when an ICD halt occurs, and remains frozen until user-mode operation resumes. The debugger may inspect the `SCANCON0` and `SCANLADR` registers to determine the state of the scan.

The ICD interaction with each operating mode is summarized in [Table 11-3](#).

TABLE 11-3: ICD AND SCANNER INTERACTIONS

ICD Halt	Scanner Operating Mode		
	Peek	Concurrent Triggered	Burst
External Halt	If Scanner would peek an instruction that is not executed (because of ICD entry), the peek will occur after ICD exit, when the instruction executes.	If external halt is asserted during a scan cycle, the instruction (delayed by scan) may or may not execute before ICD entry, depending on external halt timing.	If external halt is asserted during the <code>BSF (SCANCON.GO)</code> , ICD entry occurs, and the burst is delayed until ICD exit. Otherwise, the current NVM-access cycle will complete, and then the scanner will be interrupted for ICD entry.
		If external halt is asserted during the cycle immediately prior to the scan cycle, both scan and instruction execution happen after the ICD exits.	If external halt is asserted during the burst, the burst is suspended and will resume with ICD exit.
PC Breakpoint		Scan cycle occurs before ICD entry and instruction execution happens after the ICD exits.	If PCPB (or single step) is on <code>BSF (SCANCON.GO)</code> , the ICD is entered before execution; execution of the burst will occur at ICD exit, and the burst will run to completion.
Data Breakpoint		The instruction with the <code>dataBP</code> executes and ICD entry occurs immediately after. If scan is requested during that cycle, the scan cycle is postponed until the ICD exits.	
Single Step		If a scan cycle is ready after the debug instruction is executed, the scan will read <code>PFM</code> and then the ICD is re-entered.	
SWBP and ICDINST		If scan would stall a <code>SWBP</code> , the scan cycle occurs and the ICD is entered.	If <code>SWBP</code> replaces <code>BSF (SCANCON.GO)</code> , the ICD will be entered; instruction execution will occur at ICD exit (from <code>ICDINSTR</code> register), and the burst will run to completion.

PIC16(L)F18856/76

11.11 Register Definitions: CRC and Scanner Control

REGISTER 11-1: CRCCON0: CRC CONTROL REGISTER 0

R/W-0/0	R/W-0/0	R-0	R/W-0/0	U-0	U-0	R/W-0/0	R-0
EN	CRCGO	BUSY	ACCM	—	—	SHIFTM	FULL
bit 7							bit 0

Legend:

R = Readable bit	W = Writable bit	U = Unimplemented bit, read as '0'
u = Bit is unchanged	x = Bit is unknown	-n/n = Value at POR and BOR/Value at all other Resets
'1' = Bit is set	'0' = Bit is cleared	

- bit 7 **EN:** CRC Enable bit
1 = CRC module is released from Reset
0 = CRC is disabled and consumes no operating current
- bit 6 **CRCGO:** CRC Start bit
1 = Start CRC serial shifter
0 = CRC serial shifter turned off
- bit 5 **BUSY:** CRC Busy bit
1 = Shifting in progress or pending
0 = All valid bits in shifter have been shifted into accumulator and EMPTY = 1
- bit 4 **ACCM:** Accumulator Mode bit
1 = Data is augmented with zeros
0 = Data is not augmented with zeros
- bit 3-2 **Unimplemented:** Read as '0'
- bit 1 **SHIFTM:** Shift Mode bit
1 = Shift right (LSb)
0 = Shift left (MSb)
- bit 0 **FULL:** Data Path Full Indicator bit
1 = CRCDATH/L registers are full
0 = CRCDATH/L registers have shifted their data into the shifter

REGISTER 11-2: CRCCON1: CRC CONTROL REGISTER 1

R/W-0/0	R/W-0/0	R/W-0/0	R/W-0/0	R/W-0/0	R/W-0/0	R/W-0/0	R/W-0/0
DLEN<3:0>				PLEN<3:0>			
bit 7							bit 0

Legend:

R = Readable bit	W = Writable bit	U = Unimplemented bit, read as '0'
u = Bit is unchanged	x = Bit is unknown	-n/n = Value at POR and BOR/Value at all other Resets
'1' = Bit is set	'0' = Bit is cleared	

- bit 7-4 **DLEN<3:0>:** Data Length bits
Denotes the length of the data word -1 (See [Example 11-1](#))
- bit 3-0 **PLEN<3:0>:** Polynomial Length bits
Denotes the length of the polynomial -1 (See [Example 11-1](#))

PIC16(L)F18856/76

REGISTER 11-3: CRCDATA: CRC DATA HIGH BYTE REGISTER

R/W-xx	R/W-x/x	R/W-x/x	R/W-x/x	R/W-x/x	R/W-x/x	R/W-x/x	R/W-x/x
DAT<15:8>							
bit 7							bit 0

Legend:

R = Readable bit W = Writable bit U = Unimplemented bit, read as '0'
u = Bit is unchanged x = Bit is unknown -n/n = Value at POR and BOR/Value at all other Resets
'1' = Bit is set '0' = Bit is cleared

bit 7-0 **DAT<15:8>**: CRC Input/Output Data bits

REGISTER 11-4: CRCDATL: CRC DATA LOW BYTE REGISTER

R/W-xx	R/W-x/x	R/W-x/x	R/W-x/x	R/W-x/x	R/W-x/x	R/W-x/x	R/W-x/x
DAT<7:0>							
bit 7							bit 0

Legend:

R = Readable bit W = Writable bit U = Unimplemented bit, read as '0'
u = Bit is unchanged x = Bit is unknown -n/n = Value at POR and BOR/Value at all other Resets
'1' = Bit is set '0' = Bit is cleared

bit 7-0 **DAT<7:0>**: CRC Input/Output Data bits
Writing to this register fills the shifter.

REGISTER 11-5: CRCACCH: CRC ACCUMULATOR HIGH BYTE REGISTER

R/W-0/0	R/W-0/0	R/W-0/0	R/W-0/0	R/W-0/0	R/W-0/0	R/W-0/0	R/W-0/0
ACC<15:8>							
bit 7							bit 0

Legend:

R = Readable bit W = Writable bit U = Unimplemented bit, read as '0'
u = Bit is unchanged x = Bit is unknown -n/n = Value at POR and BOR/Value at all other Resets
'1' = Bit is set '0' = Bit is cleared

bit 7-0 **ACC<15:8>**: CRC Accumulator Register bits
Writing to this register writes to the CRC accumulator register. Reading from this register reads the CRC accumulator.

REGISTER 11-6: CRCACCL: CRC ACCUMULATOR LOW BYTE REGISTER

R/W-0/0	R/W-0/0	R/W-0/0	R/W-0/0	R/W-0/0	R/W-0/0	R/W-0/0	R/W-0/0
ACC<7:0>							
bit 7							bit 0

Legend:

R = Readable bit W = Writable bit U = Unimplemented bit, read as '0'
u = Bit is unchanged x = Bit is unknown -n/n = Value at POR and BOR/Value at all other Resets
'1' = Bit is set '0' = Bit is cleared

bit 7-0 **ACC<7:0>**: CRC Accumulator Register bits
Writing to this register writes to the CRC accumulator register through the CRC write bus. Reading from this register reads the CRC accumulator.

PIC16(L)F18856/76

REGISTER 11-7: CRCSHIFTH: CRC SHIFT HIGH BYTE REGISTER

R-0	R-0	R-0	R-0	R-0	R-0	R-0	R-0
SHIFT<15:8>							
bit 7							bit 0

Legend:		
R = Readable bit	W = Writable bit	U = Unimplemented bit, read as '0'
u = Bit is unchanged	x = Bit is unknown	-n/n = Value at POR and BOR/Value at all other Resets
'1' = Bit is set	'0' = Bit is cleared	

bit 7-0 **SHIFT<15:8>**: CRC Shifter Register bits
Reading from this register reads the CRC Shifter.

REGISTER 11-8: CRCSHIFTL: CRC SHIFT LOW BYTE REGISTER

R-0	R-0	R-0	R-0	R-0	R-0	R-0	R-0
SHIFT<7:0>							
bit 7							bit 0

Legend:		
R = Readable bit	W = Writable bit	U = Unimplemented bit, read as '0'
u = Bit is unchanged	x = Bit is unknown	-n/n = Value at POR and BOR/Value at all other Resets
'1' = Bit is set	'0' = Bit is cleared	

bit 7-0 **SHIFT<7:0>**: CRC Shifter Register bits
Reading from this register reads the CRC Shifter.

REGISTER 11-9: CRCXORH: CRC XOR HIGH BYTE REGISTER

R/W	R/W	R/W	R/W	R/W	R/W	R/W	R/W
X<15:8>							
bit 7							bit 0

Legend:		
R = Readable bit	W = Writable bit	U = Unimplemented bit, read as '0'
u = Bit is unchanged	x = Bit is unknown	-n/n = Value at POR and BOR/Value at all other Resets
'1' = Bit is set	'0' = Bit is cleared	

bit 7-0 **X<15:8>**: XOR of Polynomial Term X_N Enable bits

REGISTER 11-10: CRCXORL: CRC XOR LOW BYTE REGISTER

R/W-x/x	R/W-x/x	R/W-x/x	R/W-x/x	R/W-x/x	R/W-x/x	R/W-x/x	U-1
X<7:1>							—
bit 7							bit 0

Legend:		
R = Readable bit	W = Writable bit	U = Unimplemented bit, read as '0'
u = Bit is unchanged	x = Bit is unknown	-n/n = Value at POR and BOR/Value at all other Resets
'1' = Bit is set	'0' = Bit is cleared	

bit 7-1 **XOR<7:1>**: XOR of Polynomial Term X_N Enable bits
bit 0 **Unimplemented**: Read as '1'

PIC16(L)F18856/76

REGISTER 11-11: SCANCON0: SCANNER ACCESS CONTROL REGISTER 0

R/W-0/0	R/W/HC-0/0	R-0	R-0	R/W-0/0	U-0	R/W-0/0	R/W-0/0
EN ⁽¹⁾	SCANGO ^(2, 3)	BUSY ⁽⁴⁾	INVALID	INTM	—	MODE<1:0> ⁽⁵⁾	
bit 7							bit 0

Legend:

R = Readable bit	W = Writable bit	U = Unimplemented bit, read as '0'
u = Bit is unchanged	x = Bit is unknown	-n/n = Value at POR and BOR/Value at all other Resets
'1' = Bit is set	'0' = Bit is cleared	HC = Bit is cleared by hardware

bit 7	EN: Scanner Enable bit ⁽¹⁾ 1 = Scanner is enabled 0 = Scanner is disabled, internal states are reset
bit 6	SCANGO: Scanner GO bit ^(2, 3) 1 = When the CRC sends a ready signal, NVM will be accessed according to MDx and data passed to the client peripheral. 0 = Scanner operations will not occur
bit 5	BUSY: Scanner Busy Indicator bit ⁽⁴⁾ 1 = Scanner cycle is in process 0 = Scanner cycle is complete (or never started)
bit 4	INVALID: Scanner Abort signal bit 1 = SCANLADRL/H has incremented or contains an invalid address ⁽⁶⁾ 0 = SCANLADRL/H points to a valid address
bit 3	INTM: NVM Scanner Interrupt Management Mode Select bit <u>If MODE = 10:</u> This bit is ignored <u>If MODE = 01 (CPU is stalled until all data is transferred):</u> 1 = SCANGO is overridden (to zero) during interrupt operation; scanner resumes after returning from interrupt 0 = SCANGO is not affected by interrupts, the interrupt response will be affected <u>If MODE = 00 or 11:</u> 1 = SCANGO is overridden (to zero) during interrupt operation; scan operations resume after returning from interrupt 0 = Interrupts do not prevent NVM access
bit 2	Unimplemented: Read as '0'
bit 1-0	MODE<1:0>: Memory Access Mode bits ⁽⁵⁾ 11 = Triggered mode 10 = Peek mode 01 = Burst mode 00 = Concurrent mode

- Note 1:** Setting EN = 0 (SCANCON0 register) does not affect any other register content.
- Note 2:** This bit is cleared when LADR > HADR (and a data cycle is not occurring).
- Note 3:** If INTM = 1, this bit is overridden (to zero, but not cleared) during an interrupt response.
- Note 4:** BUSY = 1 when the NVM is being accessed, or when the CRC sends a ready signal.
- Note 5:** See [Table 11-1](#) for more detailed information.
- Note 6:** An invalid address happens when the entire range of the PFM is scanned and completed, i.e., device memory is 0x4000 and SCANHADR = 0x3FFF, after the last scan SCANLADR increments to 0x4000, the address is invalid.

PIC16(L)F18856/76

REGISTER 11-12: SCANLADRH: SCAN LOW ADDRESS HIGH BYTE REGISTER

R/W-0/0	R/W-0/0	R/W-0/0	R/W-0/0	R/W-0/0	R/W-0/0	R/W-0/0	R/W-0/0
LADR<15:8> ^(1,2)							
bit 7							bit 0

Legend:

R = Readable bit	W = Writable bit	U = Unimplemented bit, read as '0'
u = Bit is unchanged	x = Bit is unknown	-n/n = Value at POR and BOR/Value at all other Resets
'1' = Bit is set	'0' = Bit is cleared	

bit 7-0 **LADR<15:8>**: Scan Start/Current Address bits^(1,2)
 Most Significant bits of the current address to be fetched from, value increments on each fetch of memory.

- Note 1:** Registers SCANLADRH/L form a 16-bit value, but are not guarded for atomic or asynchronous access; registers should only be read or written while SCANGO = 0 (SCANCON0 register).
2: While SCANGO = 1 (SCANCON0 register), writing to this register is ignored.

REGISTER 11-13: SCANLADRL: SCAN LOW ADDRESS LOW BYTE REGISTER

R/W-0/0	R/W-0/0	R/W-0/0	R/W-0/0	R/W-0/0	R/W-0/0	R/W-0/0	R/W-0/0
LADR<7:0> ^(1,2)							
bit 7							bit 0

Legend:

R = Readable bit	W = Writable bit	U = Unimplemented bit, read as '0'
u = Bit is unchanged	x = Bit is unknown	-n/n = Value at POR and BOR/Value at all other Resets
'1' = Bit is set	'0' = Bit is cleared	

bit 7-0 **LADR<7:0>**: Scan Start/Current Address bits^(1,2)
 Least Significant bits of the current address to be fetched from, value increments on each fetch of memory

- Note 1:** Registers SCANLADRH/L form a 16-bit value, but are not guarded for atomic or asynchronous access; registers should only be read or written while SCANGO = 0 (SCANCON0 register).
2: While SCANGO = 1 (SCANCON0 register), writing to this register is ignored.

PIC16(L)F18856/76

REGISTER 11-14: SCANHADR_H: SCAN HIGH ADDRESS HIGH BYTE REGISTER

R/W-0/0	R/W-0/0	R/W-0/0	R/W-0/0	R/W-0/0	R/W-0/0	R/W-0/0	R/W-0/0
HADR<15:8> ^(1,2)							
bit 7							bit 0

Legend:

R = Readable bit	W = Writable bit	U = Unimplemented bit, read as '0'
u = Bit is unchanged	x = Bit is unknown	-n/n = Value at POR and BOR/Value at all other Resets
'1' = Bit is set	'0' = Bit is cleared	

bit 7-0 **HADR<15:8>**: Scan End Address bits^(1,2)
Most Significant bits of the address at the end of the designated scan

- Note 1:** Registers SCANHADR_H/L form a 16-bit value, but are not guarded for atomic or asynchronous access; registers should only be read or written while SCANGO = 0 (SCANCON0 register).
- 2:** While SCANGO = 1 (SCANCON0 register), writing to this register is ignored.

REGISTER 11-15: SCANHADRL: SCAN HIGH ADDRESS LOW BYTE REGISTER

R/W-0/0	R/W-0/0	R/W-0/0	R/W-0/0	R/W-0/0	R/W-0/0	R/W-0/0	R/W-0/0
HADR<7:0> ^(1,2)							
bit 7							bit 0

Legend:

R = Readable bit	W = Writable bit	U = Unimplemented bit, read as '0'
u = Bit is unchanged	x = Bit is unknown	-n/n = Value at POR and BOR/Value at all other Resets
'1' = Bit is set	'0' = Bit is cleared	

bit 7-0 **HADR<7:0>**: Scan End Address bits^(1,2)
Least Significant bits of the address at the end of the designated scan

- Note 1:** Registers SCANHADR_H/L form a 16-bit value, but are not guarded for atomic or asynchronous access; registers should only be read or written while SCANGO = 0 (SCANCON0 register).
- 2:** While SCANGO = 1 (SCANCON0 register), writing to this register is ignored.

PIC16(L)F18856/76

REGISTER 11-16: SCANTRIG: SCAN TRIGGER SELECTION REGISTER

U-0	U-0	U-0	U-0	U-0	U-0	R/W-0/0	R/W-0/0
—	—	—	—	TSEL<3:0>			
bit 7							bit 0

Legend:

R = Readable bit W = Writable bit U = Unimplemented bit, read as '0'
u = Bit is unchanged x = Bit is unknown -n/n = Value at POR and BOR/Value at all other Resets
'1' = Bit is set '0' = Bit is cleared

bit 7-4 **Unimplemented:** Read as '0'
bit 3-0 **TSEL<3:0>**: Scanner Data Trigger Input Selection bits
1111-1010 = Reserved
1001 = SMT2_Match
1000 = SMT1_Match
0111 = TMR5_Overflow
0110 = TMR4_postscaled
0101 = TMR3_Overflow
0100 = TMR2_postscaled
0011 = TMR1_Overflow
0010 = TMR0_Overflow
0001 = CLKR
0000 = LFINTOSC

TABLE 11-4: SUMMARY OF REGISTERS ASSOCIATED WITH CRC

Name	Bit 7	Bit 6	Bit 5	Bit 4	Bit 3	Bit 2	Bit 1	Bit 0	Register on Page
CRCACCH	ACC<15:8>								194
CRCACCL	ACC<7:0>								194
CRCCON0	EN	CRCGO	BUSY	ACCM	—	—	SHIFTM	FULL	193
CRCCON1	DLEN<3:0>				PLEN<3:0>				193
CRCDATH	DAT<15:8>								194
CRCDATL	DAT<7:0>								194
CRCSHIFTH	SHIFT<15:8>								195
CRCSHIFTL	SHIFT<7:0>								195
CRCXORH	XOR<15:8>								195
CRCXORL	XOR<7:1>								195
INTCON	GIE	PEIE	—	—	—	—	—	INTEDG	134
PIE4	—	—	TMR6IE	TMR5IE	TMR4IE	TMR3IE	TMR2IE	TMR1IE	139
PIR4	—	—	TMR6IF	TMR5IF	TMR4IF	TMR3IF	TMR2IF	TMR1IF	148
SCANCON0	EN	SCANGO	BUSY	INVALID	INTM	—	MODE<1:0>		196
SCANHADRH	HADR<15:8>								198
SCANHADRL	HADR<7:0>								198
SCANLADRH	LADR<15:8>								197
SCANLADRL	LADR<7:0>								197
SCANTRIG	—	—	—	—	TSEL<3:0>				199

Legend: — = unimplemented location, read as '0'. Shaded cells are not used for the CRC module.
* Page provides register information.

PIC16(L)F18856/76

12.0 I/O PORTS

TABLE 12-1: PORT AVAILABILITY PER DEVICE

Device	PORTA	PORTB	PORTC	PORTD	PORTE
PIC16(L)F18856PIC16(L)F18856	•	•	•		•
PIC16(L)F18876PIC16(L)F18876	•	•	•	•	•

Each port has ten standard registers for its operation. These registers are:

- PORTx registers (reads the levels on the pins of the device)
- LATx registers (output latch)
- TRISx registers (data direction)
- ANSELx registers (analog select)
- WPUx registers (weak pull-up)
- CCPx registers (current control positive)
- CCDNx registers (current control negative)
- INLVx (input level control)
- SLRCONx registers (slew rate)
- ODCONx registers (open-drain)

Most port pins share functions with device peripherals, both analog and digital. In general, when a peripheral is enabled on a port pin, that pin cannot be used as a general purpose output; however, the pin can still be read.

The Data Latch (LATx registers) is useful for read-modify-write operations on the value that the I/O pins are driving.

A write operation to the LATx register has the same effect as a write to the corresponding PORTx register. A read of the LATx register reads of the values held in the I/O PORT latches, while a read of the PORTx register reads the actual I/O pin value.

Ports that support analog inputs have an associated ANSELx register. When an ANSEL bit is set, the digital input buffer associated with that bit is disabled.

Disabling the input buffer prevents analog signal levels on the pin between a logic high and low from causing excessive current in the logic input circuitry. A simplified model of a generic I/O port, without the interfaces to other peripherals, is shown in Figure 12-1.

FIGURE 12-1: GENERIC I/O PORT OPERATION

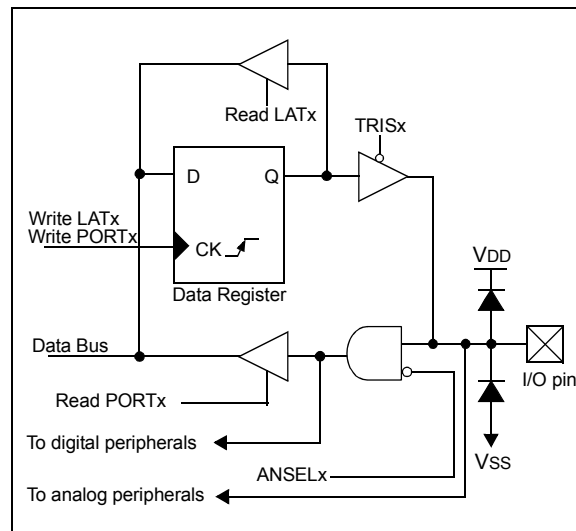

12.1 Current-Controlled Mode

Current-Controlled mode allows output currents to be regulated for both high-side and low-side drivers. All source and sink drivers for each port pin will operate at the specified current, when enabled individually by the Current-Controlled Enable registers.

Note: Current-Controlled mode is available regardless of which peripheral drives the output.

The Current-Controlled Configuration (CCDCON) register enables the Current-Controlled mode for all ports and sets the current levels.

Note: Setting CCDEN = 1 increases the device VDDIO current requirement by a fixed amount regardless of how many CCPx[n] or CCDNx[n] bits are set.

The Current-Controlled Enable registers enable each individual port pin's positive-going (CCDPx) or negative-going (CCDNx) output driver.

PIC16(L)F18856/76

12.1.1 CURRENT-CONTROLLED DRIVE

Special precautions must be taken when enabling the current-controlled output drivers. An external resistor must be inserted in series with the load to dissipate most of the power. If an external resistor is not used then the pin circuitry will dissipate all the power, thereby exceeding the maximum power specifications for the pin and the device. Determine the resistance and power rating of the external resistor such that the voltage at the pin is 0 for current sink and V_{DD} for current source when the load is drawing the maximum expected power. For example, consider a load that is expected to vary from 1.0 to 1.5 volts. When V_{DD} is 5V and the current is 1 mA then the combination of the external resistor and pin circuitry must make up the 3.5 to 4V difference. The external resistor should be sized to drop 3.5V at a current of 1 mA. The pin circuitry will then make up the 0 to 0.5 volt difference.

12.2 I/O Priorities

Each pin defaults to the PORT data latch after Reset. Other functions are selected with the peripheral pin select logic. See [Section 13.0 “Peripheral Pin Select \(PPS\) Module”](#) for more information.

Analog input functions, such as ADC and comparator inputs, are not shown in the peripheral pin select lists. These inputs are active when the I/O pin is set for Analog mode using the ANSELx register. Digital output functions may continue to control the pin when it is in Analog mode.

Analog outputs, when enabled, take priority over the digital outputs and force the digital output driver to the high-impedance state.

12.3 Register Definitions: Current-Controlled Drive Configuration

REGISTER 12-1: CCDCON REGISTER

R/W-0/0	U-0	U-0	U-0	U-0	U-0	R/W-x/u	R/W-x/u
CCDEN ⁽¹⁾	—	—	—	—	—	CCDS<1:0>	
bit 7							bit 0

Legend:

R = Readable bit

W = Writable bit

U = Unimplemented bit, read as '0'

u = Bit is unchanged

x = Bit is unknown

-n/n = Value at POR and BOR/Value at all other Resets

'1' = Bit is set

'0' = Bit is cleared

bit 7

CCDEN: Current Controlled Drive Enable bit⁽¹⁾

1 = Current-Controlled drive is enabled for all ports. Port pins enabled for current-controlled source with the CCDPxy or current-controlled sink with the CCCNxy controls will have their current limited to that selected by the CCDS selection.

0 = Current-controlled drive disabled

bit 6-2

Unimplemented: Read as '0'

bit 1-0

CCDS<1:0>: Current Controlled Drive Selection bits:

Current setting (mA):

11 = 1.0

10 = 2.0

01 = 5.0

00 = 10.0

Note 1: If either CCDPxy or CCDNxy is set when CCDEN = 0, the operation of the pin is undefined.

PIC16(L)F18856/76

12.4 PORTA Registers

12.4.1 DATA REGISTER

PORTA is an 8-bit wide, bidirectional port. The corresponding data direction register is TRISA (Register 12-3). Setting a TRISA bit (= 1) will make the corresponding PORTA pin an input (i.e., disable the output driver). Clearing a TRISA bit (= 0) will make the corresponding PORTA pin an output (i.e., enables output driver and puts the contents of the output latch on the selected pin). Example 12.4.9 shows how to initialize PORTA.

Reading the PORTA register (Register 12-2) reads the status of the pins, whereas writing to it will write to the PORT latch. All write operations are read-modify-write operations. Therefore, a write to a port implies that the port pins are read, this value is modified and then written to the PORT data latch (LATA).

The PORT data latch LATA (Register 12-4) holds the output port data, and contains the latest value of a LATA or PORTA write.

EXAMPLE 12-1: INITIALIZING PORTA

```
; This code example illustrates
; initializing the PORTA register. The
; other ports are initialized in the same
; manner.

BANKSEL PORTA      ;
CLRF PORTA         ;Init PORTA
BANKSEL LATA       ;Data Latch
CLRF LATA          ;
BANKSEL ANSELA     ;
CLRF ANSELA        ;digital I/O
BANKSEL TRISA      ;
MOVLW B'00111000' ;Set RA<5:3> as inputs
MOVWF TRISA        ;and set RA<2:0> as
                  ;outputs
```

12.4.2 DIRECTION CONTROL

The TRISA register (Register 12-3) controls the PORTA pin output drivers, even when they are being used as analog inputs. The user should ensure the bits in the TRISA register are maintained set when using them as analog inputs. I/O pins configured as analog inputs always read '0'.

12.4.3 OPEN-DRAIN CONTROL

The ODCONA register (Register 12-7) controls the open-drain feature of the port. Open-drain operation is independently selected for each pin. When an ODCONA bit is set, the corresponding port output becomes an open-drain driver capable of sinking current only. When an ODCONA bit is cleared, the corresponding port output pin is the standard push-pull drive capable of sourcing and sinking current.

Note: It is not necessary to set open-drain control when using the pin for I²C; the I²C module controls the pin and makes the pin open-drain.

12.4.4 SLEW RATE CONTROL

The SLRCONA register (Register 12-8) controls the slew rate option for each port pin. Slew rate control is independently selectable for each port pin. When an SLRCONA bit is set, the corresponding port pin drive is slew rate limited. When an SLRCONA bit is cleared, The corresponding port pin drive slews at the maximum rate possible.

PIC16(L)F18856/76

12.4.5 INPUT THRESHOLD CONTROL

The INLVLA register ([Register 12-9](#)) controls the input voltage threshold for each of the available PORTA input pins. A selection between the Schmitt Trigger CMOS or the TTL Compatible thresholds is available. The input threshold is important in determining the value of a read of the PORTA register and also the level at which an interrupt-on-change occurs, if that feature is enabled. See [Table 37-4](#) for more information on threshold levels.

Note: Changing the input threshold selection should be performed while all peripheral modules are disabled. Changing the threshold level during the time a module is active may inadvertently generate a transition associated with an input pin, regardless of the actual voltage level on that pin.

12.4.6 ANALOG CONTROL

The ANSELA register ([Register 12-5](#)) is used to configure the Input mode of an I/O pin to analog. Setting the appropriate ANSELA bit high will cause all digital reads on the pin to be read as '0' and allow analog functions on the pin to operate correctly.

The state of the ANSELA bits has no effect on digital output functions. A pin with its TRIS bit clear and its ANSEL bit set will still operate as a digital output, but the Input mode will be analog. This can cause unexpected behavior when executing read-modify-write instructions on the affected port.

Note: The ANSELA bits default to the Analog mode after Reset. To use any pins as digital general purpose or peripheral inputs, the corresponding ANSEL bits must be initialized to '0' by user software.

12.4.7 WEAK PULL-UP CONTROL

The WPUA register ([Register 12-6](#)) controls the individual weak pull-ups for each PORT pin.

12.4.8 CURRENT-CONTROL DRIVE MODE CONTROL

The CCDPA and CCDNA registers ([Register 12-9](#)) and ([Register 12-10](#)) control the Current-Controlled Drive mode for both the positive-going and negative-going drivers. When a CCDPA[y] or CCDNA[y] bit is set and the CCDEN bit of the CCDCON register is set, the current-controlled mode is enabled for the corresponding port pin. When the CCDPA[y] or CCDNA[y] bit is clear, the current-controlled mode for the corresponding port pin is disabled. If the CCDPA[y] or CCDNA[y] bit is set and the CCDEN bit is clear, operation of the port pin is undefined (see [Section 12.1.1 "Current-Controlled Drive"](#)).

12.4.9 PORTA FUNCTIONS AND OUTPUT PRIORITIES

Each PORTA pin is multiplexed with other functions.

Each pin defaults to the PORT latch data after Reset. Other output functions are selected with the peripheral pin select logic or by enabling an analog output, such as the DAC. See [Section 13.0 "Peripheral Pin Select \(PPS\) Module"](#) for more information.

Analog input functions, such as ADC and comparator inputs are not shown in the peripheral pin select lists. Digital output functions may continue to control the pin when it is in Analog mode.

PIC16(L)F18856/76

12.5 Register Definitions: PORTA

REGISTER 12-2: PORTA: PORTA REGISTER

R/W-x/u	R/W-x/u	R/W-x/u	R/W-x/u	R/W-x/u	R/W-x/u	R/W-x/u	R/W-x/u
RA7	RA6	RA5	RA4	RA3	RA2	RA1	RA0
bit 7							bit 0

Legend:

R = Readable bit

W = Writable bit

U = Unimplemented bit, read as '0'

u = Bit is unchanged

x = Bit is unknown

-n/n = Value at POR and BOR/Value at all other Resets

'1' = Bit is set

'0' = Bit is cleared

bit 7-0 **RA<7:0>**: PORTA I/O Value bits⁽¹⁾
1 = Port pin is $\geq V_{IH}$
0 = Port pin is $\leq V_{IL}$

Note 1: Writes to PORTA are actually written to corresponding LATA register. Reads from PORTA register is return of actual I/O pin values.

REGISTER 12-3: TRISA: PORTA TRI-STATE REGISTER

R/W-1/1	R/W-1/1	R/W-1/1	R/W-1/1	R/W-1/1	R/W-1/1	R/W-1/1	R/W-1/1
TRISA7	TRISA6	TRISA5	TRISA4	TRISA3	TRISA2	TRISA1	TRISA0
bit 7							bit 0

Legend:

R = Readable bit

W = Writable bit

U = Unimplemented bit, read as '0'

u = Bit is unchanged

x = Bit is unknown

-n/n = Value at POR and BOR/Value at all other Resets

'1' = Bit is set

'0' = Bit is cleared

bit 7-0 **TRISA<7:0>**: PORTA Tri-State Control bit
1 = PORTA pin configured as an input (tri-stated)
0 = PORTA pin configured as an output

PIC16(L)F18856/76

REGISTER 12-4: LATA: PORTA DATA LATCH REGISTER

R/W-x/u	R/W-x/u	R/W-x/u	R/W-x/u	R/W-x/u	R/W-x/u	R/W-x/u	R/W-x/u
LATA7	LATA6	LATA5	LATA4	LATA3	LATA2	LATA1	LATA0
bit 7							bit 0

Legend:

R = Readable bit W = Writable bit U = Unimplemented bit, read as '0'
u = Bit is unchanged x = Bit is unknown -n/n = Value at POR and BOR/Value at all other Resets
'1' = Bit is set '0' = Bit is cleared

bit 7-0 **LATA<7:0>**: RA<7:0> Output Latch Value bits⁽¹⁾

Note 1: Writes to PORTA are actually written to corresponding LATA register. Reads from PORTA register is return of actual I/O pin values.

REGISTER 12-5: ANSELA: PORTA ANALOG SELECT REGISTER

R/W-1/1	R/W-1/1	R/W-1/1	R/W-1/1	R/W-1/1	R/W-1/1	R/W-1/1	R/W-1/1
ANSA7	ANSA6	ANSA5	ANSA4	ANSA3	ANSA2	ANSA1	ANSA0
bit 7							bit 0

Legend:

R = Readable bit W = Writable bit U = Unimplemented bit, read as '0'
u = Bit is unchanged x = Bit is unknown -n/n = Value at POR and BOR/Value at all other Resets
'1' = Bit is set '0' = Bit is cleared

bit 7-0 **ANSA<7:0>**: Analog Select between Analog or Digital Function on pins RA<7:0>, respectively
1 = Analog input. Pin is assigned as analog input⁽¹⁾. Digital input buffer disabled.
0 = Digital I/O. Pin is assigned to port or digital special function.

Note 1: When setting a pin to an analog input, the corresponding TRIS bit must be set to Input mode in order to allow external control of the voltage on the pin.

PIC16(L)F18856/76

REGISTER 12-6: WPUA: WEAK PULL-UP PORTA REGISTER

R/W-0/0	R/W-0/0	R/W-0/0	R/W-0/0	R/W-0/0	R/W-0/0	R/W-0/0	R/W-0/0
WPUA7	WPUA6	WPUA5	WPUA4	WPUA3	WPUA2	WPUA1	WPUA0
bit 7							bit 0

Legend:

R = Readable bit W = Writable bit U = Unimplemented bit, read as '0'
u = Bit is unchanged x = Bit is unknown -n/n = Value at POR and BOR/Value at all other Resets
'1' = Bit is set '0' = Bit is cleared

bit 7-0 **WPUA<7:0>**: Weak Pull-up Register bits⁽¹⁾
 1 = Pull-up enabled
 0 = Pull-up disabled

Note 1: The weak pull-up device is automatically disabled if the pin is configured as an output.

REGISTER 12-7: ODCONA: PORTA OPEN-DRAIN CONTROL REGISTER

R/W-0/0	R/W-0/0	R/W-0/0	R/W-0/0	R/W-0/0	R/W-0/0	R/W-0/0	R/W-0/0
ODCA7	ODCA6	ODCA5	ODCA4	ODCA3	ODCA2	ODCA1	ODCA0
bit 7							bit 0

Legend:

R = Readable bit W = Writable bit U = Unimplemented bit, read as '0'
u = Bit is unchanged x = Bit is unknown -n/n = Value at POR and BOR/Value at all other Resets
'1' = Bit is set '0' = Bit is cleared

bit 7-0 **ODCA<7:0>**: PORTA Open-Drain Enable bits
 For RA<7:0> pins, respectively
 1 = Port pin operates as open-drain drive (sink current only)
 0 = Port pin operates as standard push-pull drive (source and sink current)

PIC16(L)F18856/76

REGISTER 12-8: SLRCONA: PORTA SLEW RATE CONTROL REGISTER

R/W-1/1	R/W-1/1	R/W-1/1	R/W-1/1	R/W-1/1	R/W-1/1	R/W-1/1	R/W-1/1
SLRA7	SLRA6	SLRA5	SLRA4	SLRA3	SLRA2	SLRA1	SLRA0
bit 7							bit 0

Legend:

R = Readable bit	W = Writable bit	U = Unimplemented bit, read as '0'
u = Bit is unchanged	x = Bit is unknown	-n/n = Value at POR and BOR/Value at all other Resets
'1' = Bit is set	'0' = Bit is cleared	

bit 7-0 **SLRA<7:0>**: PORTA Slew Rate Enable bits
 For RA<7:0> pins, respectively
 1 = Port pin slew rate is limited
 0 = Port pin slews at maximum rate

REGISTER 12-9: INLVLA: PORTA INPUT LEVEL CONTROL REGISTER

R/W-1/1	R/W-1/1	R/W-1/1	R/W-1/1	R/W-1/1	R/W-1/1	R/W-1/1	R/W-1/1
INLVLA7	INLVLA6	INLVLA5	INLVLA4	INLVLA3	INLVLA2	INLVLA1	INLVLA0
bit 7							bit 0

Legend:

R = Readable bit	W = Writable bit	U = Unimplemented bit, read as '0'
u = Bit is unchanged	x = Bit is unknown	-n/n = Value at POR and BOR/Value at all other Resets
'1' = Bit is set	'0' = Bit is cleared	

bit 7-0 **INLVLA<7:0>**: PORTA Input Level Select bits
 For RA<7:0> pins, respectively
 1 = ST input used for PORT reads and interrupt-on-change
 0 = TTL input used for PORT reads and interrupt-on-change

PIC16(L)F18856/76

REGISTER 12-10: CCDPA: CURRENT-CONTROLLED DRIVE POSITIVE PORTA REGISTER

R/W-0/0	R/W-0/0	R/W-0/0	R/W-0/0	R/W-0/0	R/W-0/0	R/W-0/0	R/W-0/0
CCDPA7	CCDPA6	CCDPA5	CCDPA4	CCDPA3	CCDPA2	CCDPA1	CCDPA0
bit 7							bit 0

Legend:

R = Readable bit W = Writable bit U = Unimplemented bit, read as '0'
u = Bit is unchanged x = Bit is unknown -n/n = Value at POR and BOR/Value at all other Resets
'1' = Bit is set '0' = Bit is cleared

bit 7-0 **CCDPA<7:0>**: RA<7:0> Current-Controlled Drive Positive Control bits
1 = Current-controlled source enabled⁽¹⁾
0 = Current-controlled source disabled

Note 1: If CCDPA_y is set, when CCDEN = 0 ([Register 12-1](#)), operation of the pin is undefined.

REGISTER 12-11: CCDNA: CURRENT-CONTROLLED DRIVE NEGATIVE PORTA REGISTER

R/W-0/0	R/W-0/0	R/W-0/0	R/W-0/0	R/W-0/0	R/W-0/0	R/W-0/0	R/W-0/0
CCDNA7	CCDNA6	CCDNA5	CCDNA4	CCDNA3	CCDNA2	CCDNA1	CCDNA0
bit 7							bit 0

Legend:

R = Readable bit W = Writable bit U = Unimplemented bit, read as '0'
u = Bit is unchanged x = Bit is unknown -n/n = Value at POR and BOR/Value at all other Resets
'1' = Bit is set '0' = Bit is cleared

bit 7-0 **CCDNA<7:0>**: RA<7:0> Current-Control Drive Negative Control bits
1 = Current-controlled source enabled⁽¹⁾
0 = Current-controlled source disabled

Note 1: If CCDNA_y is set when CCDEN = 0 ([Register 12-1](#)), operation of the pin is undefined.

PIC16(L)F18856/76

TABLE 12-2: SUMMARY OF REGISTERS ASSOCIATED WITH PORTA

Name	Bit 7	Bit 6	Bit 5	Bit 4	Bit 3	Bit 2	Bit 1	Bit 0	Register on Page
PORTA	RA7	RA6	RA5	RA4	RA3	RA2	RA1	RA0	204
TRISA	TRISA7	TRISA6	TRISA5	TRISA4	TRISA3	TRISA2	TRISA1	TRISA0	204
LATA	LATA7	LATA6	LATA5	LATA4	LATA3	LATA2	LATA1	LATA0	205
ANSELA	ANSA7	ANSA6	ANSA5	ANSA4	ANSA3	ANSA2	ANSA1	ANSA0	205
WPUA	WPUA7	WPUA6	WPUA5	WPUA4	WPUA3	WPUA2	WPUA1	WPUA0	206
ODCONA	ODCA7	ODCA6	ODCA5	ODCA4	ODCA3	ODCA2	ODCA1	ODCA0	206
SLRCONA	SLRA7	SLRA6	SLRA5	SLRA4	SLRA3	SLRA2	SLRA1	SLRA0	207
INLVLA	INLVLA7	INLVLA6	INLVLA5	INLVLA4	INLVLA3	INLVLA2	INLVLA1	INLVLA0	207
CCDPA	CCDPA7	CCDPA6	CCDPA5	CCDPA4	CCDPA3	CCDPA2	CCDPA1	CCDPA0	208
CCDNA	CCDNA7	CCDNA6	CCDNA5	CCDNA4	CCDNA3	CCDNA2	CCDNA1	CCDNA0	208
CCDCON	CCDEN	—	—	—	—	—	CCDS<1:0>		201

Legend: x = unknown, u = unchanged, — = unimplemented locations read as '0'. Shaded cells are not used by PORTA.

Note 1: Unimplemented, read as '1'.

PIC16(L)F18856/76

12.6 PORTB Registers

12.6.1 DATA REGISTER

PORTB is an 8-bit wide, bidirectional port. The corresponding data direction register is TRISB (Register 12-13). Setting a TRISB bit (= 1) will make the corresponding PORTB pin an input (i.e., disable the output driver). Clearing a TRISB bit (= 0) will make the corresponding PORTB pin an output (i.e., enables output driver and puts the contents of the output latch on the selected pin). Example 12.4.9 shows how to initialize PORTB.

Reading the PORTB register (Register 12-12) reads the status of the pins, whereas writing to it will write to the PORT latch. All write operations are read-modify-write operations. Therefore, a write to a port implies that the port pins are read, this value is modified and then written to the PORT data latch (LATB).

The PORT data latch LATB (Register 12-14) holds the output port data, and contains the latest value of a LATB or PORTB write.

EXAMPLE 12-2: INITIALIZING PORTA

```
; This code example illustrates
; initializing the PORTA register. The
; other ports are initialized in the same
; manner.

BANKSEL PORTA      ;
CLRFB PORTA        ;Init PORTA
BANKSEL LATA        ;Data Latch
CLRFB LATA          ;
BANKSEL ANSELA      ;
CLRFB ANSELA        ;digital I/O
BANKSEL TRISA       ;
MOVLW B'00111000' ;Set RA<5:3> as inputs
MOVWF TRISA         ;and set RA<2:0> as
                   ;outputs
```

12.6.2 DIRECTION CONTROL

The TRISB register (Register 12-13) controls the PORTB pin output drivers, even when they are being used as analog inputs. The user should ensure the bits in the TRISB register are maintained set when using them as analog inputs. I/O pins configured as analog inputs always read '0'.

12.6.3 OPEN-DRAIN CONTROL

The ODCONB register (Register 12-17) controls the open-drain feature of the port. Open-drain operation is independently selected for each pin. When an ODCONB bit is set, the corresponding port output becomes an open-drain driver capable of sinking current only. When an ODCONB bit is cleared, the corresponding port output pin is the standard push-pull drive capable of sourcing and sinking current.

Note: It is not necessary to set open-drain control when using the pin for I²C; the I²C module controls the pin and makes the pin open-drain.

12.6.4 SLEW RATE CONTROL

The SLRCONB register (Register 12-18) controls the slew rate option for each port pin. Slew rate control is independently selectable for each port pin. When an SLRCONB bit is set, the corresponding port pin drive is slew rate limited. When an SLRCONB bit is cleared, the corresponding port pin drive slews at the maximum rate possible.

PIC16(L)F18856/76

12.6.5 INPUT THRESHOLD CONTROL

The INLVLB register ([Register 12-9](#)) controls the input voltage threshold for each of the available PORTB input pins. A selection between the Schmitt Trigger CMOS or the TTL Compatible thresholds is available. The input threshold is important in determining the value of a read of the PORTB register and also the level at which an interrupt-on-change occurs, if that feature is enabled. See [Table 37-4](#) for more information on threshold levels.

Note: Changing the input threshold selection should be performed while all peripheral modules are disabled. Changing the threshold level during the time a module is active may inadvertently generate a transition associated with an input pin, regardless of the actual voltage level on that pin.

12.6.6 ANALOG CONTROL

The ANSELB register ([Register 12-5](#)) is used to configure the Input mode of an I/O pin to analog. Setting the appropriate ANSELA bit high will cause all digital reads on the pin to be read as '0' and allow analog functions on the pin to operate correctly.

The state of the ANSELB bits has no effect on digital output functions. A pin with its TRIS bit clear and its ANSEL bit set will still operate as a digital output, but the Input mode will be analog. This can cause unexpected behavior when executing read-modify-write instructions on the affected port.

Note: The ANSELB bits default to the Analog mode after Reset. To use any pins as digital general purpose or peripheral inputs, the corresponding ANSEL bits must be initialized to '0' by user software.

12.6.7 WEAK PULL-UP CONTROL

The WPUB register ([Register 12-6](#)) controls the individual weak pull-ups for each PORT pin.

12.6.8 CURRENT-CONTROL DRIVE MODE CONTROL

The CCDPB and CCDNB registers ([Register 12-20](#)) and ([Register 12-21](#)) control the Current-Controlled Drive mode for both the positive-going and negative-going drivers. When a CCDPB[y] or CCDNB[y] bit is set and the CC DEN bit of the CCDCON register is set, the current-controlled mode is enabled for the corresponding port pin. When the CCDPB[y] or CCDNB[y] bit is clear, the current-controlled mode for the corresponding port pin is disabled. If the CCDPB[y] or CCDNB[y] bit is set and the CC DEN bit is clear, operation of the port pin is undefined (see [Section 12.1.1 “Current-Controlled Drive”](#)).

12.6.9 PORTA FUNCTIONS AND OUTPUT PRIORITIES

Each PORTB pin is multiplexed with other functions.

Each pin defaults to the PORT latch data after Reset. Other output functions are selected with the peripheral pin select logic or by enabling an analog output, such as the DAC. See [Section 13.0 “Peripheral Pin Select \(PPS\) Module”](#) for more information.

Analog input functions, such as ADC and comparator inputs are not shown in the peripheral pin select lists. Digital output functions may continue to control the pin when it is in Analog mode.

PIC16(L)F18856/76

12.7 Register Definitions: PORTB

REGISTER 12-12: PORTB: PORTB REGISTER

R/W-x/u	R/W-x/u	R/W-x/u	R/W-x/u	R/W-x/u	R/W-x/u	R/W-x/u	R/W-x/u
RB7	RB6	RB5	RB4	RB3	RB2	RB1	RB0
bit 7							bit 0

Legend:

R = Readable bit W = Writable bit U = Unimplemented bit, read as '0'
u = Bit is unchanged x = Bit is unknown -n/n = Value at POR and BOR/Value at all other Resets
'1' = Bit is set '0' = Bit is cleared

bit 7-0 **RB<7:0>**: PORTB I/O Value bits⁽¹⁾
1 = Port pin is $\geq V_{IH}$
0 = Port pin is $\leq V_{IL}$

Note 1: Writes to PORTB are actually written to corresponding LATB register. Reads from PORTB register is return of actual I/O pin values.

REGISTER 12-13: TRISB: PORTB TRI-STATE REGISTER

R/W-1/1	R/W-1/1	R/W-1/1	R/W-1/1	R/W-1/1	R/W-1/1	R/W-1/1	R/W-1/1
TRISB7	TRISB6	TRISB5	TRISB4	TRISB3	TRISB2	TRISB1	TRISB0
bit 7							bit 0

Legend:

R = Readable bit W = Writable bit U = Unimplemented bit, read as '0'
u = Bit is unchanged x = Bit is unknown -n/n = Value at POR and BOR/Value at all other Resets
'1' = Bit is set '0' = Bit is cleared

bit 7-0 **TRISB<7:0>**: PORTB Tri-State Control bit
1 = PORTB pin configured as an input (tri-stated)
0 = PORTB pin configured as an output

PIC16(L)F18856/76

REGISTER 12-14: LATB: PORTB DATA LATCH REGISTER

R/W-x/u	R/W-x/u	R/W-x/u	R/W-x/u	R/W-x/u	R/W-x/u	R/W-x/u	R/W-x/u
LATB7	LATB6	LATB5	LATB4	LATB3	LATB2	LATB1	LATB0
bit 7							bit 0

Legend:

R = Readable bit

W = Writable bit

U = Unimplemented bit, read as '0'

u = Bit is unchanged

x = Bit is unknown

-n/n = Value at POR and BOR/Value at all other Resets

'1' = Bit is set

'0' = Bit is cleared

bit 7-0 **LATB<7:0>**: RB<7:0> Output Latch Value bits⁽¹⁾

Note 1: Writes to PORTB are actually written to corresponding LATB register. Reads from PORTB register is return of actual I/O pin values.

REGISTER 12-15: ANSELB: PORTB ANALOG SELECT REGISTER

R/W-1/1	R/W-1/1	R/W-1/1	R/W-1/1	R/W-1/1	R/W-1/1	R/W-1/1	R/W-1/1
ANSB7	ANSB6	ANSB5	ANSB4	ANSB3	ANSB2	ANSB1	ANSB0
bit 7							bit 0

Legend:

R = Readable bit

W = Writable bit

U = Unimplemented bit, read as '0'

u = Bit is unchanged

x = Bit is unknown

-n/n = Value at POR and BOR/Value at all other Resets

'1' = Bit is set

'0' = Bit is cleared

bit 7-0 **ANSB<7:0>**: Analog Select between Analog or Digital Function on pins RB<7:0>, respectively
1 = Analog input. Pin is assigned as analog input⁽¹⁾. Digital input buffer disabled.
0 = Digital I/O. Pin is assigned to port or digital special function.

Note 1: When setting a pin to an analog input, the corresponding TRIS bit must be set to Input mode in order to allow external control of the voltage on the pin.

PIC16(L)F18856/76

REGISTER 12-16: WPUB: WEAK PULL-UP PORTB REGISTER

R/W-0/0	R/W-0/0	R/W-0/0	R/W-0/0	R/W-0/0	R/W-0/0	R/W-0/0	R/W-0/0
WPUB7	WPUB6	WPUB5	WPUB4	WPUB3	WPUB2	WPUB1	WPUB0
bit 7							bit 0

Legend:

R = Readable bit W = Writable bit U = Unimplemented bit, read as '0'
u = Bit is unchanged x = Bit is unknown -n/n = Value at POR and BOR/Value at all other Resets
'1' = Bit is set '0' = Bit is cleared

bit 7-0 **WPUB<7:0>**: Weak Pull-up Register bits⁽¹⁾
 1 = Pull-up enabled
 0 = Pull-up disabled

Note 1: The weak pull-up device is automatically disabled if the pin is configured as an output.

REGISTER 12-17: ODCONB: PORTB OPEN-DRAIN CONTROL REGISTER

R/W-0/0	R/W-0/0	R/W-0/0	R/W-0/0	R/W-0/0	R/W-0/0	R/W-0/0	R/W-0/0
ODCB7	ODCB6	ODCB5	ODCB4	ODCB3	ODCB2	ODCB1	ODCB0
bit 7							bit 0

Legend:

R = Readable bit W = Writable bit U = Unimplemented bit, read as '0'
u = Bit is unchanged x = Bit is unknown -n/n = Value at POR and BOR/Value at all other Resets
'1' = Bit is set '0' = Bit is cleared

bit 7-0 **ODCB<7:0>**: PORTB Open-Drain Enable bits
 For RB<7:0> pins, respectively
 1 = Port pin operates as open-drain drive (sink current only)
 0 = Port pin operates as standard push-pull drive (source and sink current)

PIC16(L)F18856/76

REGISTER 12-18: SLRCONB: PORTB SLEW RATE CONTROL REGISTER

R/W-1/1	R/W-1/1	R/W-1/1	R/W-1/1	R/W-1/1	R/W-1/1	R/W-1/1	R/W-1/1
SLRB7	SLRB6	SLRB5	SLRB4	SLRB3	SLRB2	SLRB1	SLRB0
bit 7							bit 0

Legend:

R = Readable bit	W = Writable bit	U = Unimplemented bit, read as '0'
u = Bit is unchanged	x = Bit is unknown	-n/n = Value at POR and BOR/Value at all other Resets
'1' = Bit is set	'0' = Bit is cleared	

bit 7-0 **SLRB<7:0>**: PORTB Slew Rate Enable bits
 For RB<7:0> pins, respectively
 1 = Port pin slew rate is limited
 0 = Port pin slews at maximum rate

REGISTER 12-19: INLVLB: PORTB INPUT LEVEL CONTROL REGISTER

R/W-1/1	R/W-1/1	R/W-1/1	R/W-1/1	R/W-1/1	R/W-1/1	R/W-1/1	R/W-1/1
INLVLB7	INLVLB6	INLVLB5	INLVLB4	INLVLB3	INLVLB2	INLVLB1	INLVLB0
bit 7							bit 0

Legend:

R = Readable bit	W = Writable bit	U = Unimplemented bit, read as '0'
u = Bit is unchanged	x = Bit is unknown	-n/n = Value at POR and BOR/Value at all other Resets
'1' = Bit is set	'0' = Bit is cleared	

bit 7-0 **INLVLB<7:0>**: PORTB Input Level Select bits
 For RB<7:0> pins, respectively
 1 = ST input used for PORT reads and interrupt-on-change
 0 = TTL input used for PORT reads and interrupt-on-change

PIC16(L)F18856/76

REGISTER 12-20: CCDPB: CURRENT CONTROLLED DRIVE POSITIVE PORTB REGISTER

R/W-0/0	R/W-0/0	R/W-0/0	R/W-0/0	R/W-0/0	R/W-0/0	R/W-0/0	R/W-0/0
CCDPB7	CCDPB6	CCDPB5	CCDPB4	CCDPB3	CCDPB2	CCDPB1	CCDPB0
bit 7							bit 0

Legend:

R = Readable bit W = Writable bit U = Unimplemented bit, read as '0'
u = Bit is unchanged x = Bit is unknown -n/n = Value at POR and BOR/Value at all other Resets
'1' = Bit is set '0' = Bit is cleared

bit 7-0 **CCDPB<7:0>**: RB<7:0> Current Controlled Drive Positive Control bits
1 = Current-controlled source enabled⁽¹⁾
0 = Current-controlled source disabled

Note 1: If CCDPB_y is set, when CCDEN = 0 ([Register 12-1](#)), operation of the pin is undefined.

REGISTER 12-21: CCDNB: CURRENT CONTROLLED DRIVE NEGATIVE PORTB REGISTER

R/W-0/0	R/W-0/0	R/W-0/0	R/W-0/0	R/W-0/0	R/W-0/0	R/W-0/0	R/W-0/0
CCDNB7	CCDNB6	CCDNB5	CCDNB4	CCDNB3	CCDNB2	CCDNB1	CCDNB0
bit 7							bit 0

Legend:

R = Readable bit W = Writable bit U = Unimplemented bit, read as '0'
u = Bit is unchanged x = Bit is unknown -n/n = Value at POR and BOR/Value at all other Resets
'1' = Bit is set '0' = Bit is cleared

bit 7-0 **CCDNB<7:0>**: RB<7:0> Current Controlled Drive Negative Control bits
1 = Current-controlled source enabled⁽¹⁾
0 = Current-controlled source disabled

Note 1: If CCDNB_y is set when CCDEN = 0 ([Register 12-1](#)), operation of the pin is undefined.

PIC16(L)F18856/76

TABLE 12-3: SUMMARY OF REGISTERS ASSOCIATED WITH PORTB

Name	Bit 7	Bit 6	Bit 5	Bit 4	Bit 3	Bit 2	Bit 1	Bit 0	Register on Page
PORTB	RB7	RB6	RB5	RB4	RB3	RB2	RB1	RB0	212
TRISB	TRISB7	TRISB6	TRISB5	TRISB4	TRISB3	TRISB2	TRISB1	TRISB0	212
LATB	LATB7	LATB6	LATB5	LATB4	LATB3	LATB2	LATB1	LATB0	213
ANSELB	ANSB7	ANSB6	ANSB5	ANSB4	ANSB3	ANSB2	ANSB1	ANSB0	213
WPUB	WPUB7	WPUB6	WPUB5	WPUB4	WPUB3	WPUB2	WPUB1	WPUB0	214
ODCONB	ODCB7	ODCB6	ODCB5	ODCB4	ODCB3	ODCB2	ODCB1	ODCB0	214
SLRCONB	SLRB7	SLRB6	SLRB5	SLRB4	SLRB3	SLRB2	SLRB1	SLRB0	215
INLVLB	INLVLB7	INLVLB6	INLVLB5	INLVLB4	INLVLB3	INLVLB2	INLVLB1	INLVLB0	215
CCDPB	CCDPB7	CCDPB6	CCDPB5	CCDPB4	CCDPB3	CCDPB2	CCDPB1	CCDPB0	216
CCDNB	CCDNB7	CCDNB6	CCDNB5	CCDNB4	CCDNB3	CCDNB2	CCDNB1	CCDNB0	216
CCDCON	CCDEN	—	—	—	—	—	CCDS<1:0>		201

Legend: x = unknown, u = unchanged, — = unimplemented locations read as '0'. Shaded cells are not used by PORTB.

Note 1: Unimplemented, read as '1'.

PIC16(L)F18856/76

12.8 PORTC Registers

12.8.1 DATA REGISTER

PORTC is an 8-bit wide bidirectional port. The corresponding data direction register is TRISC (Register 12-23). Setting a TRISC bit (= 1) will make the corresponding PORTC pin an input (i.e., put the corresponding output driver in a High-Impedance mode). Clearing a TRISC bit (= 0) will make the corresponding PORTC pin an output (i.e., enable the output driver and put the contents of the output latch on the selected pin). Example 12.4.9 shows how to initialize an I/O port.

Reading the PORTC register (Register 12-22) reads the status of the pins, whereas writing to it will write to the PORT latch. All write operations are read-modify-write operations. Therefore, a write to a port implies that the port pins are read, this value is modified and then written to the PORT data latch (LATC).

The PORT data latch LATC (Register 12-24) holds the output port data, and contains the latest value of a LATC or PORTC write.

12.8.2 DIRECTION CONTROL

The TRISC register (Register 12-23) controls the PORTC pin output drivers, even when they are being used as analog inputs. The user should ensure the bits in the TRISC register are maintained set when using them as analog inputs. I/O pins configured as analog inputs always read '0'.

12.8.3 INPUT THRESHOLD CONTROL

The INLVLC register (Register 12-29) controls the input voltage threshold for each of the available PORTC input pins. A selection between the Schmitt Trigger CMOS or the TTL Compatible thresholds is available. The input threshold is important in determining the value of a read of the PORTC register and also the level at which an interrupt-on-change occurs, if that feature is enabled. See Table 37-4 for more information on threshold levels.

Note: Changing the input threshold selection should be performed while all peripheral modules are disabled. Changing the threshold level during the time a module is active may inadvertently generate a transition associated with an input pin, regardless of the actual voltage level on that pin.

12.8.4 OPEN-DRAIN CONTROL

The ODCONC register (Register 12-27) controls the open-drain feature of the port. Open-drain operation is independently selected for each pin. When an ODCONC bit is set, the corresponding port output becomes an open-drain driver capable of sinking current only. When an ODCONC bit is cleared, the corresponding port output pin is the standard push-pull drive capable of sourcing and sinking current.

Note: It is not necessary to set open-drain control when using the pin for I²C; the I²C module controls the pin and makes the pin open-drain.

12.8.5 SLEW RATE CONTROL

The SLRCONC register (Register 12-28) controls the slew rate option for each port pin. Slew rate control is independently selectable for each port pin. When an SLRCONC bit is set, the corresponding port pin drive is slew rate limited. When an SLRCONC bit is cleared, the corresponding port pin drive slews at the maximum rate possible.

12.8.6 ANALOG CONTROL

The ANSEL register (Register 12-25) is used to configure the Input mode of an I/O pin to analog. Setting the appropriate ANSEL bit high will cause all digital reads on the pin to be read as '0' and allow analog functions on the pin to operate correctly.

The state of the ANSEL bits has no effect on digital output functions. A pin with TRIS clear and ANSEL set will still operate as a digital output, but the Input mode will be analog. This can cause unexpected behavior when executing read-modify-write instructions on the affected port.

Note: The ANSEL bits default to the Analog mode after Reset. To use any pins as digital general purpose or peripheral inputs, the corresponding ANSEL bits must be initialized to '0' by user software.

12.8.7 WEAK PULL-UP CONTROL

The WPUC register (Register 12-26) controls the individual weak pull-ups for each port pin.

PIC16(L)F18856/76

12.8.8 CURRENT-CONTROLLED DRIVE MODE CONTROL

The CCDPC and CCDNC registers ([Register 12-30](#) and [Register 12-31](#)) control the Current-Controlled Drive mode for both the positive-going and negative-going drivers. When a CCDPC[y] or CCDNC[y] bit is set and the CCDEN bit of the CCDCON register is set, the Current-Controlled mode is enabled for the corresponding port pin. When the CCDPC[y] or CCDNC[y] bit is clear, the Current-Controlled mode for the corresponding port pin is disabled. If the CCDPC[y] or CCDNC[y] bit is set and the CCDEN bit is clear, operation of the port pin is undefined (see [Section 12.1.1 “Current-Controlled Drive”](#) for current-controlled use precautions).

12.8.9 PORTC FUNCTIONS AND OUTPUT PRIORITIES

Each pin defaults to the PORT latch data after Reset. Other output functions are selected with the peripheral pin select logic. See [Section 13.0 “Peripheral Pin Select \(PPS\) Module”](#) for more information.

Analog input functions, such as ADC and comparator inputs, are not shown in the peripheral pin select lists. Digital output functions may continue to control the pin when it is in Analog mode.

PIC16(L)F18856/76

12.9 Register Definitions: PORTC

REGISTER 12-22: PORTC: PORTC REGISTER

R/W-x/u	R/W-x/u	R/W-x/u	R/W-x/u	R/W-x/u	R/W-x/u	R/W-x/u	R/W-x/u
RC7	RC6	RC5	RC4	RC3	RC2	RC1	RC0
bit 7							bit 0

Legend:

R = Readable bit W = Writable bit U = Unimplemented bit, read as '0'
u = Bit is unchanged x = Bit is unknown -n/n = Value at POR and BOR/Value at all other Resets
'1' = Bit is set '0' = Bit is cleared

bit 7-0 **RC<7:0>**: PORTC General Purpose I/O Pin bits⁽¹⁾
1 = Port pin is $\geq V_{IH}$
0 = Port pin is $\leq V_{IL}$

Note 1: Writes to PORTC are actually written to corresponding LATC register. Reads from PORTC register is return of actual I/O pin values.

REGISTER 12-23: TRISC: PORTC TRI-STATE REGISTER

R/W-1/1	R/W-1/1	R/W-1/1	R/W-1/1	R/W-1/1	R/W-1/1	R/W-1/1	R/W-1/1
TRISC7	TRISC6	TRISC5	TRISC4	TRISC3	TRISC2	TRISC1	TRISC0
bit 7							bit 0

Legend:

R = Readable bit W = Writable bit U = Unimplemented bit, read as '0'
u = Bit is unchanged x = Bit is unknown -n/n = Value at POR and BOR/Value at all other Resets
'1' = Bit is set '0' = Bit is cleared

bit 7-0 **TRISC<7:0>**: PORTC Tri-State Control bits
1 = PORTC pin configured as an input (tri-stated)
0 = PORTC pin configured as an output

REGISTER 12-24: LATC: PORTC DATA LATCH REGISTER

R/W-x/u	R/W-x/u	R/W-x/u	R/W-x/u	R/W-x/u	R/W-x/u	R/W-x/u	R/W-x/u
LATC7	LATC6	LATC5	LATC4	LATC3	LATC2	LATC1	LATC0
bit 7							bit 0

Legend:

R = Readable bit W = Writable bit U = Unimplemented bit, read as '0'
u = Bit is unchanged x = Bit is unknown -n/n = Value at POR and BOR/Value at all other Resets
'1' = Bit is set '0' = Bit is cleared

bit 7-0 **LATC<7:0>**: PORTC Output Latch Value bits

PIC16(L)F18856/76

REGISTER 12-25: ANSELC: PORTC ANALOG SELECT REGISTER

R/W-1/1	R/W-1/1	R/W-1/1	R/W-1/1	R/W-1/1	R/W-1/1	R/W-1/1	R/W-1/1
ANSC7	ANSC6	ANSC5	ANSC4	ANSC3	ANSC2	ANSC1	ANSC0
bit 7							bit 0

Legend:

R = Readable bit W = Writable bit U = Unimplemented bit, read as '0'
u = Bit is unchanged x = Bit is unknown -n/n = Value at POR and BOR/Value at all other Resets
'1' = Bit is set '0' = Bit is cleared

bit 7-0 **ANSC<7:0>**: Analog Select between Analog or Digital Function on Pins RC<7:0>, respectively⁽¹⁾
0 = Digital I/O. Pin is assigned to port or digital special function.
1 = Analog input. Pin is assigned as analog input⁽¹⁾. Digital input buffer disabled.

Note 1: When setting a pin to an analog input, the corresponding TRIS bit must be set to Input mode in order to allow external control of the voltage on the pin.

REGISTER 12-26: WPUC: WEAK PULL-UP PORTC REGISTER

R/W-0/0	R/W-0/0	R/W-0/0	R/W-0/0	R/W-0/0	R/W-0/0	R/W-0/0	R/W-0/0
WPUC7	WPUC6	WPUC5	WPUC4	WPUC3	WPUC2	WPUC1	WPUC0
bit 7							bit 0

Legend:

R = Readable bit W = Writable bit U = Unimplemented bit, read as '0'
u = Bit is unchanged x = Bit is unknown -n/n = Value at POR and BOR/Value at all other Resets
'1' = Bit is set '0' = Bit is cleared

bit 7-0 **WPUC<7:0>**: Weak Pull-up Register bits⁽¹⁾
1 = Pull-up enabled
0 = Pull-up disabled

Note 1: The weak pull-up device is automatically disabled if the pin is configured as an output.

PIC16(L)F18856/76

REGISTER 12-27: ODCONC: PORTC OPEN-DRAIN CONTROL REGISTER

R/W-0/0	R/W-0/0	R/W-0/0	R/W-0/0	R/W-0/0	R/W-0/0	R/W-0/0	R/W-0/0
ODCC7	ODCC6	ODCC5	ODCC4	ODCC3	ODCC2	ODCC1	ODCC0
bit 7							bit 0

Legend:

R = Readable bit W = Writable bit U = Unimplemented bit, read as '0'
u = Bit is unchanged x = Bit is unknown -n/n = Value at POR and BOR/Value at all other Resets
'1' = Bit is set '0' = Bit is cleared

bit 7-0 **ODCC<7:0>**: PORTC Open-Drain Enable bits
For RC<7:0> pins, respectively
1 = Port pin operates as open-drain drive (sink current only)
0 = Port pin operates as standard push-pull drive (source and sink current)

REGISTER 12-28: SLRCONC: PORTC SLEW RATE CONTROL REGISTER

R/W-1/1	R/W-1/1	R/W-1/1	R/W-1/1	R/W-1/1	R/W-1/1	R/W-1/1	R/W-1/1
SLRC7	SLRC6	SLRC5	SLRC4	SLRC3	SLRC2	SLRC1	SLRC0
bit 7							bit 0

Legend:

R = Readable bit W = Writable bit U = Unimplemented bit, read as '0'
u = Bit is unchanged x = Bit is unknown -n/n = Value at POR and BOR/Value at all other Resets
'1' = Bit is set '0' = Bit is cleared

bit 7-0 **SLRC<7:0>**: PORTC Slew Rate Enable bits
For RC<7:0> pins, respectively
1 = Port pin slew rate is limited
0 = Port pin slews at maximum rate

REGISTER 12-29: INLVLC: PORTC INPUT LEVEL CONTROL REGISTER

R/W-1/1	R/W-1/1	R/W-1/1	R/W-1/1	R/W-1/1	R/W-1/1	R/W-1/1	R/W-1/1
INLVLC7	INLVLC6	INLVLC5	INLVLC4	INLVLC3	INLVLC2	INLVLC1	INLVLC0
bit 7							bit 0

Legend:

R = Readable bit W = Writable bit U = Unimplemented bit, read as '0'
u = Bit is unchanged x = Bit is unknown -n/n = Value at POR and BOR/Value at all other Resets
'1' = Bit is set '0' = Bit is cleared

bit 7-0 **INLVLC<7:0>**: PORTC Input Level Select bits
For RC<7:0> pins, respectively
1 = ST input used for PORT reads and interrupt-on-change
0 = TTL input used for PORT reads and interrupt-on-change

PIC16(L)F18856/76

REGISTER 12-30: CCDPC: CURRENT CONTROLLED DRIVE POSITIVE PORTC REGISTER

R/W-0/0	R/W-0/0	R/W-0/0	R/W-0/0	R/W-0/0	R/W-0/0	R/W-0/0	R/W-0/0
CCDPC7	CCDPC6	CCDPC5	CCDPC4	CCDPC3	CCDPC2	CCDPC1	CCDPC0
bit 7							bit 0

Legend:

R = Readable bit W = Writable bit U = Unimplemented bit, read as '0'
u = Bit is unchanged x = Bit is unknown -n/n = Value at POR and BOR/Value at all other Resets
'1' = Bit is set '0' = Bit is cleared

bit 7-0 **CCDPC<7:0>**: RC<7:0> Current Controlled Drive Positive Control bits⁽¹⁾
1 = Current-controlled source enabled
0 = Current-controlled source disabled

Note 1: If CCDPCy is set, when CC DEN = 0 ([Register 12-1](#)), operation of the pin is undefined.

REGISTER 12-31: CCDNC: CURRENT CONTROLLED DRIVE NEGATIVE PORTC REGISTER

R/W-0/0	R/W-0/0	R/W-0/0	R/W-0/0	R/W-0/0	R/W-0/0	R/W-0/0	R/W-0/0
CCDNC7	CCDNC6	CCDNC5	CCDNC4	CCDNC3	CCDNC2	CCDNC1	CCDNC0
bit 7							bit 0

Legend:

R = Readable bit W = Writable bit U = Unimplemented bit, read as '0'
u = Bit is unchanged x = Bit is unknown -n/n = Value at POR and BOR/Value at all other Resets
'1' = Bit is set '0' = Bit is cleared

bit 7-0 **CCDNC<7:0>**: RC<7:0> Current Controlled Drive Negative Control bits⁽¹⁾
1 = Current-controlled source enabled
0 = Current-controlled source disabled

Note 1: If CCDNCy is set, when CC DEN = 0 ([Register 12-1](#)), operation of the pin is undefined.

PIC16(L)F18856/76

TABLE 12-4: SUMMARY OF REGISTERS ASSOCIATED WITH PORTC

Name	Bit 7	Bit 6	Bit 5	Bit 4	Bit 3	Bit 2	Bit 1	Bit 0	Register on Page
PORTC	RC7	RC6	RC5	RC4	RC3	RC2	RC1	RC0	220
TRISC	TRISC7	TRISC6	TRISC5	TRISC4	TRISC3	TRISC2	TRISC1	TRISC0	220
LATC	LATC7	LATC6	LATC5	LATC4	LATC3	LATC2	LATC1	LATC0	220
ANSEL	ANSEL7	ANSEL6	ANSEL5	ANSEL4	ANSEL3	ANSEL2	ANSEL1	ANSEL0	221
WPUC	WPUC7	WPUC6	WPUC5	WPUC4	WPUC3	WPUC2	WPUC1	WPUC0	221
ODCONC	ODCC7	ODCC6	ODCC5	ODCC4	ODCC3	ODCC2	ODCC1	ODCC0	222
SLRCONC	SLRC7	SLRC6	SLRC5	SLRC4	SLRC3	SLRC2	SLRC1	SLRC0	222
INLVLC	INLVLC7	INLVLC6	INLVLC5	INLVLC4	INLVLC3	INLVLC2	INLVLC1	INLVLC0	222
CCDPC	CCDPC7	CCDPC6	CCDPC5	CCDPC4	CCDPC3	CCDPC2	CCDPC1	CCDPC0	223
CCDNC	CCDNC7	CCDNC6	CCDNC5	CCDNC4	CCDNC3	CCDNC2	CCDNC1	CCDNC0	223
CCDCON	CCDEN	—	—	—	—	—	CCDS<1:0>		201

Legend: — = unimplemented locations read as '0'. Shaded cells are not used by PORTC.

PIC16(L)F18856/76

12.10 PORTD Registers (PIC16(L)F18876 only)

12.10.1 DATA REGISTER CONTROL

PORTD is an 8-bit wide bidirectional port. The corresponding data direction register is TRISD (Register 12-33). Setting a TRISD bit (= 1) will make the corresponding PORTC pin an input (i.e., put the corresponding output driver in a High-Impedance mode). Clearing a TRISD bit (= 0) will make the corresponding PORTD pin an output (i.e., enable the output driver and put the contents of the output latch on the selected pin). Example 12.4.9 shows how to initialize an I/O port.

Reading the PORTD register (Register 12-32) reads the status of the pins, whereas writing to it will write to the PORT latch. All write operations are read-modify-write operations. Therefore, a write to a port implies that the port pins are read, this value is modified and then written to the PORT data latch (LATD).

The PORT data latch LATD (Register 12-34) holds the output port data, and contains the latest value of a LATD or PORTD write.

12.10.2 DIRECTION CONTROL

The TRISD register (Register 12-33) controls the PORTD pin output drivers, even when they are being used as analog inputs. The user should ensure the bits in the TRISD register are maintained set when using them as analog inputs. I/O pins configured as analog inputs always read '0'.

12.10.3 INPUT THRESHOLD CONTROL

The INLVLD register (Register 12-39) controls the input voltage threshold for each of the available PORTD input pins. A selection between the Schmitt Trigger CMOS or the TTL Compatible thresholds is available. The input threshold is important in determining the value of a read of the PORTD register and also the level at which an interrupt-on-change occurs, if that feature is enabled. See Table 37-4 for more information on threshold levels.

Note: Changing the input threshold selection should be performed while all peripheral modules are disabled. Changing the threshold level during the time a module is active may inadvertently generate a transition associated with an input pin, regardless of the actual voltage level on that pin.

12.10.4 OPEN-DRAIN CONTROL

The ODCOND register (Register 12-37) controls the open-drain feature of the port. Open-drain operation is independently selected for each pin. When an ODCOND bit is set, the corresponding port output becomes an open-drain driver capable of sinking current only. When an ODCOND bit is cleared, the corresponding port output pin is the standard push-pull drive capable of sourcing and sinking current.

Note: It is not necessary to set open-drain control when using the pin for I²C; the I²C module controls the pin and makes the pin open-drain.

12.10.5 SLEW RATE CONTROL

The SLRCOND register (Register 12-38) controls the slew rate option for each port pin. Slew rate control is independently selectable for each port pin. When an SLRCOND bit is set, the corresponding port pin drive is slew rate limited. When an SLRCOND bit is cleared, The corresponding port pin drive slews at the maximum rate possible.

12.10.6 ANALOG CONTROL

The ANSELD register (Register 12-35) is used to configure the Input mode of an I/O pin to analog. Setting the appropriate ANSELD bit high will cause all digital reads on the pin to be read as '0' and allow analog functions on the pin to operate correctly.

The state of the ANSELD bits has no effect on digital output functions. A pin with TRIS clear and ANSELD set will still operate as a digital output, but the Input mode will be analog. This can cause unexpected behavior when executing read-modify-write instructions on the affected port.

Note: The ANSELD bits default to the Analog mode after Reset. To use any pins as digital general purpose or peripheral inputs, the corresponding ANSEL bits must be initialized to '0' by user software.

12.10.7 WEAK PULL-UP CONTROL

The WPUD register (Register 12-36) controls the individual weak pull-ups for each port pin.

PIC16(L)F18856/76

12.10.8 CURRENT-CONTROLLED DRIVE MODE CONTROL

The CCDPD and CCDND registers ([Register 12-40](#) and [Register 12-41](#)) control the Current-Controlled Drive mode for both the positive-going and negative-going drivers. When a CCDPD[y] or CCDND[y] bit is set and the CCDEN bit of the CCDCON register is set, the Current-Controlled mode is enabled for the corresponding port pin. When the CCDPD[y] or CCDND[y] bit is clear, the Current-Controlled mode for the corresponding port pin is disabled. If the CCDPD[y] or CCDND[y] bit is set and the CCDEN bit is clear, operation of the port pin is undefined (see [Section 12.1.1 “Current-Controlled Drive”](#) for current-controlled use precautions).

12.10.9 PORTD FUNCTIONS AND OUTPUT PRIORITIES

Each pin defaults to the PORT latch data after Reset. Other output functions are selected with the peripheral pin select logic. See [Section 13.0 “Peripheral Pin Select \(PPS\) Module”](#) for more information.

Analog input functions, such as ADC and comparator inputs, are not shown in the peripheral pin select lists. Digital output functions may continue to control the pin when it is in Analog mode.

PIC16(L)F18856/76

12.11 Register Definitions: PORTD

REGISTER 12-32: PORTD: PORTD REGISTER

R/W-x/u	R/W-x/u	R/W-x/u	R/W-x/u	R/W-x/u	R/W-x/u	R/W-x/u	R/W-x/u
RD7	RD6	RD5	RD4	RD3	RD2	RD1	RD0
bit 7							bit 0

Legend:

R = Readable bit

W = Writable bit

U = Unimplemented bit, read as '0'

u = Bit is unchanged

x = Bit is unknown

-n/n = Value at POR and BOR/Value at all other Resets

'1' = Bit is set

'0' = Bit is cleared

bit 7-0 **RD<7:0>**: PORTD I/O Value bits⁽¹⁾1 = Port pin is $\geq V_{IH}$ 0 = Port pin is $\leq V_{IL}$

Note 1: Writes to PORTD are actually written to corresponding LATD register. Reads from PORTD register is return of actual I/O pin values.

REGISTER 12-33: TRISD: PORTD TRI-STATE REGISTER

R/W-x/u	R/W-x/u	R/W-x/u	R/W-x/u	R/W-x/u	R/W-x/u	R/W-x/u	R/W-x/u
TRISD7	TRISD6	TRISD5	TRISD4	TRISD3	TRISD2	TRISD1	TRISD0
bit 7							bit 0

Legend:

R = Readable bit

W = Writable bit

U = Unimplemented bit, read as '0'

u = Bit is unchanged

x = Bit is unknown

-n/n = Value at POR and BOR/Value at all other Resets

'1' = Bit is set

'0' = Bit is cleared

bit 7-0 **TRISD<7:0>**: TRISD I/O Value bits1 = Port pin is $\geq V_{IH}$ 0 = Port pin is $\leq V_{IL}$

PIC16(L)F18856/76

REGISTER 12-34: LATD: PORTD TRI-STATE REGISTER

R/W-x/u	R/W-x/u	R/W-x/u	R/W-x/u	R/W-x/u	R/W-x/u	R/W-x/u	R/W-x/u
LATD7	LATD6	LATD5	LATD4	LATD3	LATD2	LATD1	LATD0
bit 7							bit 0

Legend:

R = Readable bit	W = Writable bit	U = Unimplemented bit, read as '0'
u = Bit is unchanged	x = Bit is unknown	-n/n = Value at POR and BOR/Value at all other Resets
'1' = Bit is set	'0' = Bit is cleared	

bit 7-0 **LATD<7:0>**: LATD I/O Value bits⁽¹⁾
 1 = Port pin is $\geq V_{IH}$
 0 = Port pin is $\leq V_{IL}$

Note 1: Writes to LATD are actually written to corresponding LATD register. Reads from PORTD register is return of actual I/O pin values.

REGISTER 12-35: ANSEL: PORTD TRI-STATE REGISTER

R/W-x/u	R/W-x/u	R/W-x/u	R/W-x/u	R/W-x/u	R/W-x/u	R/W-x/u	R/W-x/u
ANS7	ANS6	ANS5	ANS4	ANS3	ANS2	ANS1	ANS0
bit 7							bit 0

Legend:

R = Readable bit	W = Writable bit	U = Unimplemented bit, read as '0'
u = Bit is unchanged	x = Bit is unknown	-n/n = Value at POR and BOR/Value at all other Resets
'1' = Bit is set	'0' = Bit is cleared	

bit 7-0 **ANS<7:0>**: ANSD I/O Value bits⁽¹⁾
 1 = Port pin is $\geq V_{IH}$
 0 = Port pin is $\leq V_{IL}$

Note 1: When setting a pin to an analog input, the corresponding TRIS bit must be set to Input mode in order to allow external control of the voltage on the pin.0

PIC16(L)F18856/76

REGISTER 12-36: WPUD: WEAK PULL-UP PORTD REGISTER

R/W-x/u	R/W-x/u	R/W-x/u	R/W-x/u	R/W-x/u	R/W-x/u	R/W-x/u	R/W-x/u
WPUD7	WPUD6	WPUD5	WPUD4	WPUD3	WPUD2	WPUD1	WPUD0
bit 7							bit 0

Legend:

R = Readable bit

W = Writable bit

U = Unimplemented bit, read as '0'

u = Bit is unchanged

x = Bit is unknown

-n/n = Value at POR and BOR/Value at all other Resets

'1' = Bit is set

'0' = Bit is cleared

bit 7-0 **WPUD<7:0>**: WPUD I/O Value bits⁽¹⁾

1 = Port pin is $\geq V_{IH}$

0 = Port pin is $\leq V_{IL}$

Note 1: The weak pull-up device is automatically disabled if the pin is configured as an output.

REGISTER 12-37: ODCD: PORTD OPEN-DRAIN CONTROL REGISTER

R/W-x/u	R/W-x/u	R/W-x/u	R/W-x/u	R/W-x/u	R/W-x/u	R/W-x/u	R/W-x/u
ODCD7	ODCD6	ODCD5	ODCD4	ODCD3	ODCD2	ODCD1	ODCD0
bit 7							bit 0

Legend:

R = Readable bit

W = Writable bit

U = Unimplemented bit, read as '0'

u = Bit is unchanged

x = Bit is unknown

-n/n = Value at POR and BOR/Value at all other Resets

'1' = Bit is set

'0' = Bit is cleared

bit 7-0 **ODCD<7:0>**: ODCD I/O Value bits

1 = Port pin is $\geq V_{IH}$

0 = Port pin is $\leq V_{IL}$

PIC16(L)F18856/76

REGISTER 12-38: SLRCOND: PORTD SLEW RATE CONTROL REGISTER

R/W-1/1	R/W-1/1	R/W-1/1	R/W-1/1	R/W-1/1	R/W-1/1	R/W-1/1	R/W-1/1
SLRD7	SLRD6	SLRD5	SLRD4	SLRD3	SLRD2	SLRD1	SLRD0
bit 7							bit 0

Legend:

R = Readable bit

W = Writable bit

U = Unimplemented bit, read as '0'

u = Bit is unchanged

x = Bit is unknown

-n/n = Value at POR and BOR/Value at all other Resets

'1' = Bit is set

'0' = Bit is cleared

bit 7-0 **SLRD<7:0>**: PORTD Slew Rate Enable bits
For RD<7:0> pins, respectively
1 = Port pin slew rate is limited
0 = Port pin slews at maximum rate

REGISTER 12-39: INLVLD: PORTD INPUT LEVEL CONTROL REGISTER

R/W-1/1	R/W-1/1	R/W-1/1	R/W-1/1	R/W-1/1	R/W-1/1	R/W-1/1	R/W-1/1
INLVLD7	INLVLD6	INLVLD5	INLVLD4	INLVLD3	INLVLD2	INLVLD1	INLVLD0
bit 7							bit 0

Legend:

R = Readable bit

W = Writable bit

U = Unimplemented bit, read as '0'

u = Bit is unchanged

x = Bit is unknown

-n/n = Value at POR and BOR/Value at all other Resets

'1' = Bit is set

'0' = Bit is cleared

bit 7-0 **INLVLD<7:0>**: PORTD Input Level Select bits
For RD<7:0> pins, respectively
1 = ST input used for PORT reads and interrupt-on-change
0 = TTL input used for PORT reads and interrupt-on-change

PIC16(L)F18856/76

REGISTER 12-40: CCDPD: CURRENT CONTROLLED DRIVE POSITIVE PORTD REGISTER

R/W-0/0	R/W-0/0	R/W-0/0	R/W-0/0	R/W-0/0	R/W-0/0	R/W-0/0	R/W-0/0
CCDPD7	CCDPD6	CCDPD5	CCDPD4	CCDPD3	CCDPD2	CCDPD1	CCDPD0
bit 7							bit 0

Legend:

R = Readable bit W = Writable bit U = Unimplemented bit, read as '0'
u = Bit is unchanged x = Bit is unknown -n/n = Value at POR and BOR/Value at all other Resets
'1' = Bit is set '0' = Bit is cleared

bit 7-0 **CCDPD<7:0>**: RD<7:0> Current Controlled Drive Positive Control bits⁽¹⁾
1 = Current controlled source enabled
0 = Current controlled source disabled

Note 1: If CCDPDy is set, when CCDEN = 0 (Register 12-1), operation of the pin is undefined.

REGISTER 12-41: CCDND: CURRENT CONTROLLED DRIVE NEGATIVE PORTD REGISTER

R/W-0/0	R/W-0/0	R/W-0/0	R/W-0/0	R/W-0/0	R/W-0/0	R/W-0/0	R/W-0/0
CCDND7	CCDND6	CCDND5	CCDND4	CCDND3	CCDND2	CCDND1	CCDND0
bit 7							bit 0

Legend:

R = Readable bit W = Writable bit U = Unimplemented bit, read as '0'
u = Bit is unchanged x = Bit is unknown -n/n = Value at POR and BOR/Value at all other Resets
'1' = Bit is set '0' = Bit is cleared

bit 7-0 **CCDND<7:0>**: RD<7:0> Current Controlled Drive Negative Control bits⁽¹⁾
1 = Current controlled source enabled
0 = Current controlled source disabled

Note 1: If CCDNDy is set, when CCDEN = 0 (Register 12-1), operation of the pin is undefined.

TABLE 12-5: SUMMARY OF REGISTERS ASSOCIATED WITH PORTD⁽¹⁾

Name	Bit 7	Bit 6	Bit 5	Bit 4	Bit 3	Bit 2	Bit 1	Bit 0	Register on Page
PORTD	RD7	RD6	RD5	RD4	RD3	RD2	RD1	RD0	227
TRISD	TRISD7	TRISD6	TRISD5	TRISD4	TRISD3	TRISD2	TRISD1	TRISD0	227
LATD	LATD7	LATD6	LATD5	LATD4	LATD3	LATD2	LATD1	LATD0	228
ANSELD	ANS7	ANS6	ANS5	ANS4	ANS3	ANS2	ANS1	ANS0	228
WPUD	WPUD7	WPUD6	WPUD5	WPUD4	WPUD3	WPUD2	WPUD1	WPUD0	229
ODCOND	ODCD7	ODCD6	ODCD5	ODCD4	ODCD3	ODCD2	ODCD1	ODCD0	229
SLRCOND	SLRD7	SLRD6	SLRD5	SLRD4	SLRD3	SLRD2	SLRD1	SLRD0	230
INLVLD	INLVLD7	INLVLD6	INLVLD5	INLVLD4	INLVLD3	INLVLD2	INLVLD1	INLVLD0	230
CCDPD	CCDPD7	CCDPD6	CCDPD5	CCDPD4	CCDPD3	CCDPD2	CCDPD1	CCDPD0	231
CCDND	CCDND7	CCDND6	CCDND5	CCDND4	CCDND3	CCDND2	CCDND1	CCDND0	231
CCDCON	CCDEN	—	—	—	—	—	CCDS<1:0>		201

Legend: — = unimplemented locations read as '0'. Shaded cells are not used by PORTD.

Note 1: PIC16(L)F18876 only.

PIC16(L)F18856/76

12.12 PORTE Registers (PIC16(L)F18856)

12.12.1 DATA REGISTER

PORTE is a 4-bit wide, bidirectional port. The corresponding data direction register is TRISE (Register 12-42). Setting a TRISE bit (= 1) will make the corresponding PORTE pin an input (i.e., disable the output driver). Clearing a TRISE bit (= 0) will make the corresponding PORTE pin an output (i.e., enables output driver and puts the contents of the output latch on the selected pin). Example 12.4.9 shows how to initialize PORTE.

Reading the PORTE register (Register 12-42) reads the status of the pins, whereas writing to it will write to the PORT latch. All write operations are read-modify-write operations. Therefore, a write to a port implies that the port pins are read, this value is modified and then written to the PORT data latch (LATE).

12.12.2 INPUT THRESHOLD CONTROL

The INLVLE register (Register 12-44) controls the input voltage threshold for each of the available PORTE input pins. A selection between the Schmitt Trigger CMOS or the TTL Compatible thresholds is available. The input threshold is important in determining the value of a read of the PORTE register and also the level at which an interrupt-on-change occurs, if that feature is enabled. See Table 37-4 for more information on threshold levels.

Note: Changing the input threshold selection should be performed while all peripheral modules are disabled. Changing the threshold level during the time a module is active may inadvertently generate a transition associated with an input pin, regardless of the actual voltage level on that pin.

12.12.3 WEAK PULL-UP CONTROL

The WPUE register (Register 12-43) controls the individual weak pull-ups for each port pin.

12.12.4 PORTE FUNCTIONS AND OUTPUT PRIORITIES

Each pin defaults to the PORT latch data after Reset. Other output functions are selected with the peripheral pin select logic. See Section 13.0 “Peripheral Pin Select (PPS) Module” for more information.

Analog input functions, such as ADC and comparator inputs, are not shown in the peripheral pin select lists. Digital output functions may continue to control the pin when it is in Analog mode.

12.12.5 PORTE FUNCTIONS AND OUTPUT PRIORITIES

Each pin defaults to the PORT latch data after Reset. Other output functions are selected with the peripheral pin select logic. See Section 13.0 “Peripheral Pin Select (PPS) Module” for more information.

Analog input functions, such as ADC and comparator inputs, are not shown in the peripheral pin select lists. Digital output functions may continue to control the pin when it is in Analog mode.

PIC16(L)F18856/76

12.13 Register Definitions: PORTE (PIC16(L)F18856)

REGISTER 12-42: PORTE: PORTE REGISTER

U-0	U-0	U-0	U-0	R-x/u	U-0	U-0	U-0
—	—	—	—	RE3	—	—	—
bit 7				bit 0			

Legend:

R = Readable bit	W = Writable bit	U = Unimplemented bit, read as '0'
u = Bit is unchanged	x = Bit is unknown	-n/n = Value at POR and BOR/Value at all other Resets
'1' = Bit is set	'0' = Bit is cleared	

bit 7-4 **Unimplemented:** Read as '0'

bit 3 **RE<3>**: PORTE Input Pin bit
 1 = Port pin is > VIH
 0 = Port pin is < VIL

bit 2-0 **Unimplemented:** Read as '0'

REGISTER 12-43: WPUE: WEAK PULL-UP PORTE REGISTER

U-0	U-0	U-0	U-0	R/W-1/1	U-0	U-0	U-0
—	—	—	—	WPUE3	—	—	—
bit 7				bit 0			

Legend:

R = Readable bit	W = Writable bit	U = Unimplemented bit, read as '0'
u = Bit is unchanged	x = Bit is unknown	-n/n = Value at POR and BOR/Value at all other Resets
'1' = Bit is set	'0' = Bit is cleared	

bit 7-4 **Unimplemented:** Read as '0'

bit 3 **WPUE3**: Weak Pull-up Register bit⁽¹⁾
 1 = Pull-up enabled
 0 = Pull-up disabled

bit 2-0 **Unimplemented:** Read as '0'

Note 1: The weak pull-up device is automatically disabled if the pin is configured as an output.

PIC16(L)F18856/76

REGISTER 12-44: INLVLE: PORTE INPUT LEVEL CONTROL REGISTER

U-0	U-0	U-0	U-0	R/W-1/1	U-0	U-0	U-0
—	—	—	—	INLVLE3	—	—	—
bit 7							bit 0

Legend:

R = Readable bit W = Writable bit U = Unimplemented bit, read as '0'
u = Bit is unchanged x = Bit is unknown -n/n = Value at POR and BOR/Value at all other Resets
'1' = Bit is set '0' = Bit is cleared

bit 7-4 **Unimplemented:** Read as '0'
bit 3 **INLVLE3:** PORTE Input Level Select bits
 For RE3 pin,
 1 = ST input used for PORT reads and interrupt-on-change
 0 = TTL input used for PORT reads and interrupt-on-change
bit 2-0 **Unimplemented:** Read as '0'

TABLE 12-6: SUMMARY OF REGISTERS ASSOCIATED WITH PORTE

Name	Bit 7	Bit 6	Bit 5	Bit 4	Bit 3	Bit 2	Bit 1	Bit 0	Register on Page
PORTE	—	—	—	—	RE3	—	—	—	233
WPUE	—	—	—	—	WPUE3	—	—	—	233
INLVLE	—	—	—	—	INLVLE3	—	—	—	234

Legend: x = unknown, u = unchanged, — = unimplemented locations read as '0'. Shaded cells are not used by PORTE.

TABLE 12-7: SUMMARY OF CONFIGURATION WORD WITH PORTE

Name	Bits	Bit -/7	Bit -/6	Bit 13/5	Bit 12/4	Bit 11/3	Bit 10/2	Bit 9/1	Bit 8/0	Register on Page
CONFIG2	13:8	—	—	DEBUG	STVREN	PPS1WAY	ZCDDIS	BORV	—	93
	7:0	BOREN<1:0>		LPBOREN	—	—	—	PWRTE	MCLRE	

Legend: — = unimplemented location, read as '0'. Shaded cells are not used by PORTE.

PIC16(L)F18856/76

12.14 PORTE Registers (PIC16(L)F18876)

12.14.1 DATA REGISTER

PORTE is a 4-bit wide, bidirectional port. The corresponding data direction register is TRISE (Register 12-46). Setting a TRISE bit (= 1) will make the corresponding PORTE pin an input (i.e., disable the output driver). Clearing a TRISE bit (= 0) will make the corresponding PORTE pin an output (i.e., enables output driver and puts the contents of the output latch on the selected pin). Example 12.4.9 shows how to initialize PORTE.

Reading the PORTE register (Register 12-45) reads the status of the pins, whereas writing to it will write to the PORT latch. All write operations are read-modify-write operations. Therefore, a write to a port implies that the port pins are read, this value is modified and then written to the PORT data latch (LATE).

The PORT data latch LATE (Register 12-47) holds the output port data, and contains the latest value of a LATE or PORTE write.

12.14.2 DIRECTION CONTROL

The TRISE register (Register 12-46) controls the PORTE pin output drivers, even when they are being used as analog inputs. The user should ensure the bits in the TRISE register are maintained set when using them as analog inputs. I/O pins configured as analog inputs always read '0'.

12.14.3 INPUT THRESHOLD CONTROL

The INLVLE register (Register 12-52) controls the input voltage threshold for each of the available PORTE input pins. A selection between the Schmitt Trigger CMOS or the TTL Compatible thresholds is available. The input threshold is important in determining the value of a read of the PORTE register and also the level at which an interrupt-on-change occurs, if that feature is enabled. See Table 37-4 for more information on threshold levels.

Note: Changing the input threshold selection should be performed while all peripheral modules are disabled. Changing the threshold level during the time a module is active may inadvertently generate a transition associated with an input pin, regardless of the actual voltage level on that pin.

12.14.4 OPEN-DRAIN CONTROL

The ODCONE register (Register 12-50) controls the open-drain feature of the port. Open-drain operation is independently selected for each pin. When an ODCONE bit is set, the corresponding port output becomes an open-drain driver capable of sinking current only. When an ODCONE bit is cleared, the corresponding port output pin is the standard push-pull drive capable of sourcing and sinking current.

Note: It is not necessary to set open-drain control when using the pin for I²C; the I²C module controls the pin and makes the pin open-drain.

12.14.5 SLEW RATE CONTROL

The SLRCONE register (Register 12-51) controls the slew rate option for each port pin. Slew rate control is independently selectable for each port pin. When an SLRCONE bit is set, the corresponding port pin drive is slew rate limited. When an SLRCONE bit is cleared, the corresponding port pin drive slews at the maximum rate possible.

12.14.6 ANALOG CONTROL

The ANSELE register (Register 12-48) is used to configure the Input mode of an I/O pin to analog. Setting the appropriate ANSELE bit high will cause all digital reads on the pin to be read as '0' and allow analog functions on the pin to operate correctly.

The state of the ANSELE bits has no effect on digital output functions. A pin with TRIS clear and ANSELE set will still operate as a digital output, but the Input mode will be analog. This can cause unexpected behavior when executing read-modify-write instructions on the affected port.

Note: The ANSELC bits default to the Analog mode after Reset. To use any pins as digital general purpose or peripheral inputs, the corresponding ANSEL bits must be initialized to '0' by user software.

12.14.7 WEAK PULL-UP CONTROL

The WPUE register (Register 12-49) controls the individual weak pull-ups for each port pin.

PIC16(L)F18856/76

12.14.8 CURRENT-CONTROLLED DRIVE MODE CONTROL

The CCDPE and CCDNE registers ([Register 12-53](#) and [Register 12-54](#)) control the Current-Controlled Drive mode for both the positive-going and negative-going drivers. When a CCDPE[y] or CCDNE[y] bit is set and the CCDEN bit of the CCDCON register is set, the Current-Controlled mode is enabled for the corresponding port pin. When the CCDPE[y] or CCDNE[y] bit is clear, the Current-Controlled mode for the corresponding port pin is disabled. If the CCDPE[y] or CCDNE[y] bit is set and the CCDEN bit is clear, operation of the port pin is undefined (see [Section 12.1.1 “Current-Controlled Drive”](#) for current-controlled use precautions).

12.14.9 PORTE FUNCTIONS AND OUTPUT PRIORITIES

Each pin defaults to the PORT latch data after Reset. Other output functions are selected with the peripheral pin select logic. See [Section 13.0 “Peripheral Pin Select \(PPS\) Module”](#) for more information.

Analog input functions, such as ADC and comparator inputs, are not shown in the peripheral pin select lists. Digital output functions may continue to control the pin when it is in Analog mode.

12.14.10 PORTE FUNCTIONS AND OUTPUT PRIORITIES

Each pin defaults to the PORT latch data after Reset. Other output functions are selected with the peripheral pin select logic. See [Section 13.0 “Peripheral Pin Select \(PPS\) Module”](#) for more information.

Analog input functions, such as ADC and comparator inputs, are not shown in the peripheral pin select lists. Digital output functions may continue to control the pin when it is in Analog mode.

PIC16(L)F18856/76

12.15 Register Definitions: PORTE (PIC16(L)F18876)

REGISTER 12-45: PORTE: PORTE REGISTER

U-0	U-0	U-0	U-0	R-x/u	R/W-x/u	R/W-x/u	R/W-x/u
—	—	—	—	RE3	RE2	RE1	RE0
bit 7							bit 0

Legend:

R = Readable bit	W = Writable bit	U = Unimplemented bit, read as '0'
u = Bit is unchanged	x = Bit is unknown	-n/n = Value at POR and BOR/Value at all other Resets
'1' = Bit is set	'0' = Bit is cleared	

bit 7-4 **Unimplemented:** Read as '0'

bit 3-0 **RE<3:0>:** PORTE Input Pin bit
 1 = Port pin is > V_{IH}
 0 = Port pin is < V_{IL}

Note 1: Writes to RE<2:0> are actually written to the corresponding LATE register. Reads from the PORTE register is the return of actual I/O pin values.

REGISTER 12-46: TRISE: PORTE TRI-STATE REGISTER

U-0	U-0	U-0	U-0	U-1 ⁽¹⁾	R/W-x/u	R/W-x/u	R/W-x/u
—	—	—	—	—	TRISE2	TRISE1	TRISE0
bit 7							bit 0

Legend:

R = Readable bit	W = Writable bit	U = Unimplemented bit, read as '0'
u = bit is unchanged	x = Bit is unknown	-n/n = Value at POR and BOR/Value at all other Resets
'1' = Bit is set	'0' = Bit is cleared	

bit 7-4 **Unimplemented:** Read as '0'

bit 3 **Unimplemented:** Read as '1'

bit 2-0 **TRISE<2:0>:** TRISE I/O Value bits⁽²⁾
 1 = Port pin is ≥ V_{IH}
 0 = Port pin is ≤ V_{IL}

Note 1: Unimplemented, read as '1'.

PIC16(L)F18856/76

REGISTER 12-47: LATE: PORTE DATA LATCH REGISTER

U-0	U-0	U-0	U-0	U-0	R/W-x/u	R/W-x/u	R/W-x/u
—	—	—	—	—	LATE2	LATE1	LATE0
bit 7					bit 0		

Legend:

R = Readable bit W = Writable bit U = Unimplemented bit, read as '0'
u = Bit is unchanged x = Bit is unknown -n/n = Value at POR and BOR/Value at all other Resets
'1' = Bit is set '0' = Bit is cleared

bit 7-3 **Unimplemented:** Read as '0'
bit 2-0 **LATE<2:0>:** PORTE Output Latch Value bits⁽¹⁾

Note 1: Writes to PORTE are actually written to the corresponding LATE register. Reads from the PORTE register is return of actual I/O pin values.

REGISTER 12-48: ANSELE: PORTE ANALOG SELECT REGISTER

U-0	U-0	U-0	U-0	U-0	R/W-1/1	R/W-1/1	R/W-1/1
—	—	—	—	—	ANSE2	ANSE1	ANSE0
bit 7					bit 0		

Legend:

R = Readable bit W = Writable bit U = Unimplemented bit, read as '0'
u = Bit is unchanged x = Bit is unknown -n/n = Value at POR and BOR/Value at all other Resets
'1' = Bit is set '0' = Bit is cleared

bit 7-3 **Unimplemented:** Read as '0'
bit 2-0 **ANSE<2:0>:** Analog Select between Analog or Digital Function on pins RE<2:0>, respectively
0 = Digital I/O. Pin is assigned to port or digital special function.
1 = Analog input. Pin is assigned as analog input⁽¹⁾. Digital input buffer disabled.

Note 1: When setting a pin to an analog input, the corresponding TRIS bit must be set to Input mode in order to allow external control of the voltage on the pin.

PIC16(L)F18856/76

REGISTER 12-49: WPUE: WEAK PULL-UP PORTE REGISTER

U-0	U-0	U-0	U-0	R/W-1/1	R/W-1/1	R/W-1/1	R/W-1/1
—	—	—	—	WPUE3	WPUE2	WPUE1	WPUE0
bit 7							bit 0

Legend:

R = Readable bit	W = Writable bit	U = Unimplemented bit, read as '0'
u = Bit is unchanged	x = Bit is unknown	-n/n = Value at POR and BOR/Value at all other Resets
'1' = Bit is set	'0' = Bit is cleared	

bit 7-4 **Unimplemented:** Read as '0'

bit 3-0 **WPUE<3:0>** Weak Pull-up Register bit⁽¹⁾
 1 = Pull-up enabled
 0 = Pull-up disabled

Note 1: The weak pull-up device is automatically disabled if the pin is configured as an output.

REGISTER 12-50: ODCONE: PORTE OPEN-DRAIN CONTROL REGISTER

U-0	U-0	U-0	U-0	U-0	R/W-0/0	R/W-0/0	R/W-0/0
—	—	—	—	—	ODCE2	ODCE1	ODCE0
bit 7							bit 0

Legend:

R = Readable bit	W = Writable bit	U = Unimplemented bit, read as '0'
u = Bit is unchanged	x = Bit is unknown	-n/n = Value at POR and BOR/Value at all other Resets
'1' = Bit is set	'0' = Bit is cleared	

bit 7-3 **Unimplemented:** Read as '0'

bit 2-0 **ODCE<2:0>**: PORTE Open-Drain Enable bits
 For RE<2:0> pins, respectively
 1 = Port pin operates as open-drain drive (sink current only)
 0 = Port pin operates as standard push-pull drive (source and sink current)

PIC16(L)F18856/76

REGISTER 12-51: SLRCONE: PORTE SLEW RATE CONTROL REGISTER

U-0	U-0	U-0	U-0	U-0	R/W-1/1	R/W-1/1	R/W-1/1
—	—	—	—	—	SLRE2	SLRE1	SLRE0
bit 7						bit 0	

Legend:

R = Readable bit	W = Writable bit	U = Unimplemented bit, read as '0'
u = Bit is unchanged	x = Bit is unknown	-n/n = Value at POR and BOR/Value at all other Resets
'1' = Bit is set	'0' = Bit is cleared	

bit 7-3 **Unimplemented:** Read as '0'

bit 2-0 **SLRE<2:0>:** PORTE Slew Rate Enable bits
 For RE<2:0> pins, respectively
 1 = Port pin slew rate is limited
 0 = Port pin slews at maximum rate

REGISTER 12-52: INLVLE: PORTE INPUT LEVEL CONTROL REGISTER

U-0	U-0	U-0	U-0	R/W-1/1	R/W-1/1	R/W-1/1	R/W-1/1
—	—	—	—	INLVLE3	INLVLE2	INLVLE1	INLVLE0
bit 7						bit 0	

Legend:

R = Readable bit	W = Writable bit	U = Unimplemented bit, read as '0'
u = Bit is unchanged	x = Bit is unknown	-n/n = Value at POR and BOR/Value at all other Resets
'1' = Bit is set	'0' = Bit is cleared	

bit 7-4 **Unimplemented:** Read as '0'

bit 3-0 **INLVLE<3:0>:** PORTE Input Level Select bits
 For RE<3:0> pins, respectively
 1 = ST input used for PORT reads and interrupt-on-change
 0 = TTL input used for PORT reads and interrupt-on-change

PIC16(L)F18856/76

REGISTER 12-53: CCDPE: CURRENT CONTROL DRIVE NEGATIVE PORTE REGISTER

U-0	U-0	U-0	U-0	U-0	R/W-0/0	R/W-0/0	R/W-0/0
—	—	—	—	—	CCDPE2	CCDPE1	CCDPE0
bit 7							bit 0

Legend:

R = Readable bit

W = Writable bit

U = Unimplemented bit, read as '0'

u = Bit is unchanged

x = Bit is unknown

-n/n = Value at POR and BOR/Value at all other Resets

'1' = Bit is set

'0' = Bit is cleared

bit 7-3 **Unimplemented:** Read as '0'

bit 2-0 **CCDPE<2:0>:** RE<2:0> Current Control Drive Positive Control bits⁽¹⁾

1 = Current control source enabled

0 = Current control source disabled

Note 1: If CCDPEy is set, when CCDEN = 0 ([Register 12-1](#)), operation of the pin is undefined.

REGISTER 12-54: CCDNE: CURRENT CONTROL DRIVE NEGATIVE PORTE REGISTER

U-0	U-0	U-0	U-0	U-0	R/W-0/0	R/W-0/0	R/W-0/0
—	—	—	—	—	CCDNE2	CCDNE1	CCDNE0
bit 7							bit 0

Legend:

R = Readable bit

W = Writable bit

U = Unimplemented bit, read as '0'

u = Bit is unchanged

x = Bit is unknown

-n/n = Value at POR and BOR/Value at all other Resets

'1' = Bit is set

'0' = Bit is cleared

bit 7-3 **Unimplemented:** Read as '0'

bit 2-0 **CCDNE<2:0>:** RE<2:0> Current Control Drive Negative Control bits⁽¹⁾

1 = Current control source enabled

0 = Current control source disabled

Note 1: If CCDNEy is set, when CCDEN = 0 ([Register 12-1](#)), operation of the pin is undefined.

PIC16(L)F18856/76

TABLE 12-8: SUMMARY OF REGISTERS ASSOCIATED WITH PORTE⁽¹⁾

Name	Bit 7	Bit 6	Bit 5	Bit 4	Bit 3	Bit 2	Bit 1	Bit 0	Register on Page
PORTE	—	—	—	—	RE3	RE2	RE1	RE0	227
TRISE	—	—	—	—	— ⁽¹⁾	TRISE2	TRISE1	TRISE0	227
LATE	—	—	—	—	—	LATE2	LATE1	LATE0	228
ANSELE	—	—	—	—	—	ANSE2	ANSE1	ANSE0	228
WPUE	—	—	—	—	WPUE3	WPUE2	WPUE1	WPUE0	229
ODCONE	—	—	—	—	—	ODCE2	ODCE1	ODCE0	229
SLRCONE	—	—	—	—	—	SLRE2	SLRE1	SLRE0	230
INLVLE	—	—	—	—	INLVLE3	INLVLE2	INLVLE1	INLVLE0	230
CCDPE	—	—	—	—	—	CCDPE2	CCDPE1	CCDPE0	231
CCDNE	—	—	—	—	—	CCDNE2	CCDNE1	CCDNE0	231
CCDCON	CCDEN	—	—	—	—	—	CCDS<1:0>		201

Legend: x = unknown, u = unchanged, — = unimplemented locations read as '0'. Shaded cells are not used by PORTE.

Note 1: Unimplemented, read as '1'.

TABLE 12-9: SUMMARY OF CONFIGURATION WORD WITH PORTE

Name	Bits	Bit -/7	Bit -/6	Bit 13/5	Bit 12/4	Bit 11/3	Bit 10/2	Bit 9/1	Bit 8/0	Register on Page
CONFIG2	13:8	—	—	$\overline{\text{DEBUG}}$	STVREN	PPS1WAY	ZCDDIS	BORV	—	93
	7:0	BOREN<1:0>		$\overline{\text{LPBOREN}}$	—	—	—	$\overline{\text{PWRTTE}}$	MCLRE	

Legend: — = unimplemented location, read as '0'. Shaded cells are not used by PORTE.

PIC16(L)F18856/76

13.0 PERIPHERAL PIN SELECT (PPS) MODULE

The Peripheral Pin Select (PPS) module connects peripheral inputs and outputs to the device I/O pins. Only digital signals are included in the selections. All analog inputs and outputs remain fixed to their assigned pins. Input and output selections are independent as shown in the simplified block diagram [Figure 13-1](#).

TABLE 13-1: PPS INPUT SIGNAL ROUTING OPTIONS

Input Signal Name	Input Register Name	Default Location at POR	Remappable to Pins of PORTx							
			PIC16F18856			PIC16F18876				
			PORTA	PORTB	PORTC	PORTA	PORTB	PORTC	PORTD	PORTE
INT	INTPPS	RB0	•	•		•	•			
T0CKI	T0CKIPPS	RA4	•	•		•	•			
T1CKI	T1CKIPPS	RC0	•		•	•		•		
T1G	T1GPPS	RB5		•	•		•	•		
T3CKI	T3CKIPPS	RC0		•	•		•	•		
T3G	T3GPPS	RC0	•		•	•		•		
T5CKI	T5CKIPPS	RC2	•		•	•		•		
T5G	T5GPPS	RB4		•	•		•		•	
T2IN	T2INPPS	RC3	•		•		•		•	
T4IN	T4INPPS	RC5		•	•		•	•		
T6IN	T6INPPS	RB7		•	•		•		•	
CCP1	CCP1PPS	RC2		•	•		•	•		
CCP2	CCP2PPS	RC1		•	•		•	•		
CCP3	CCP3PPS	RB5		•	•		•		•	
CCP4	CCP4PPS	RB0		•	•		•		•	
CCP5	CCP5PPS	RA4	•		•	•				•
SMTWIN1	SMTWIN1PPS	RC0		•	•		•			
SMTSIG1	SMTSIG1PPS	RC1		•	•		•			
SMTWIN2	SMTWIN2PPS	RB4		•	•		•		•	
SMTSIG2	SMTSIG2PPS	RB5		•	•		•		•	
CWG1IN	CWG1PPS	RB0		•	•		•		•	
CWG2IN	CWG2PPS	RB1		•	•		•		•	
CWG3IN	CWG3PPS	RB2		•	•		•		•	
MDCARL	MDCARLPPS	RA3	•		•	•			•	
MDCARH	MDCARHPPS	RA4	•		•	•			•	
MDMSRC	MDSRCPPS	RA5	•		•	•			•	
CLCIN0	CLCIN0PPS	RA0	•		•	•		•		
CLCIN1	CLCIN1PPS	RA1	•		•	•		•		
CLCIN2	CLCIN2PPS	RB6		•	•		•		•	

PIC16(L)F18856/76

TABLE 13-1: PPS INPUT SIGNAL ROUTING OPTIONS (CONTINUED)

Input Signal Name	Input Register Name	Default Location at POR	Remappable to Pins of PORTx							
			PIC16F18856			PIC16F18876				
			PORTA	PORTB	PORTC	PORTA	PORTB	PORTC	PORTD	PORTE
CLCIN3	CLCIN3PPS	RB7		•	•		•		•	
ADCACT	ADCACTPPS	RB4		•	•		•		•	
SCK1/SCL1	SSP1CLKPPS	RC3		•	•		•	•		
SDI1/SDA1	SSP1DATPPS	RC4		•	•		•	•		
SS1	SSPSS1PPS	RA5	•		•	•			•	
SCK2/SCL2	SSP2CLKPPS	RB1		•	•		•		•	
SDI2/SDA2	SSP2DATPPS	RB2		•	•		•		•	
SS2	SSP2SSPPS	RB0		•	•		•		•	
RX/DT	RXPPS	RC7		•	•		•	•		
CK	TXPPS	RC6		•	•		•	•		

PIC16(L)F18856/76

TABLE 13-2: PPS INPUT REGISTER VALUES

Desired Input Pin	Value to Write to Register ⁽¹⁾
RA0	0x00
RA1	0x01
RA2	0x02
RA3	0x03
RA4	0x04
RA5	0x05
RA6	0x06
RA7	0x07
RB0	0x08
RB1	0x09
RB2	0x0A
RB3	0x0B
RB4	0x0C
RB5	0x0D
RB6	0x0E
RB7	0x0F
RC0	0x10
RC1	0x11
RC2	0x12
RC3	0x13
RC4	0x14
RC5	0x15
RC6	0x16
RC7	0x17
RD0	0x18
RD1	0x19
RD2	0x1A
RD3	0x1B
RD4	0x1C
RD5	0x1D
RD6	0x1E
RD7	0x1F
RE0	0x20
RE1	0x21
RE2	0x22
RE3	0x23

Note 1: Only a few of the values in this column are valid for any given signal. For example, since the INT signal can only be mapped to PORTA or PORTB pins, only the register values 0x00-0x0F (corresponding to RA<7:0> and RB<7:0>) are valid values to write to the INTPPS register.

PIC16(L)F18856/76

13.1 PPS Inputs

Each peripheral has a PPS register with which the inputs to the peripheral are selected. Inputs include the device pins.

Although every peripheral has its own PPS input selection register, the selections are identical for every peripheral as shown in [Register 13-1](#).

Note: The notation “xxx” in the register name is a place holder for the peripheral identifier. For example, CLC1PPS.

13.2 PPS Outputs

Each I/O pin has a PPS register with which the pin output source is selected. With few exceptions, the port TRIS control associated with that pin retains control over the pin output driver. Peripherals that control the pin output driver as part of the peripheral operation will override the TRIS control as needed. These peripherals include:

- EUSART (synchronous operation)
- MSSP (I²C)

Although every pin has its own PPS peripheral selection register, the selections are identical for every pin as shown in [Register 13-2](#).

Note: The notation “Rxy” is a place holder for the pin port and bit identifiers. For example, x and y for PORTA bit 0 would be A and 0, respectively, resulting in the pin PPS output selection register RA0PPS.

FIGURE 13-1: SIMPLIFIED PPS BLOCK DIAGRAM

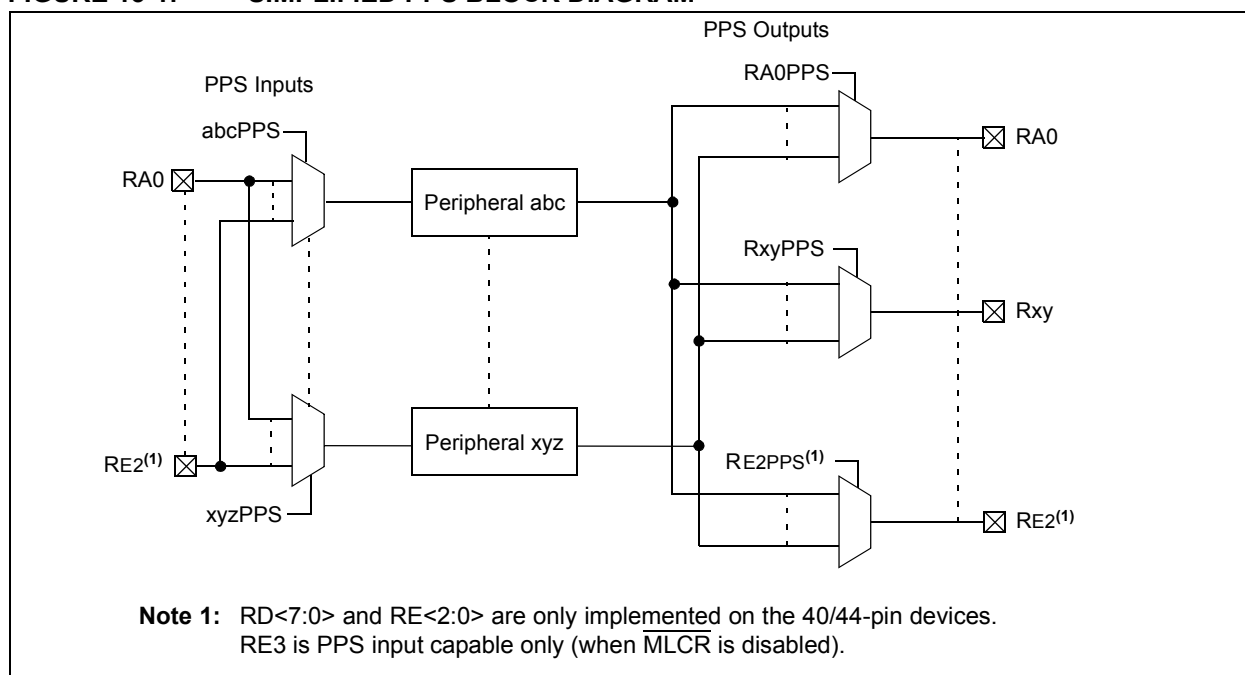

PIC16(L)F18856/76

13.3 Bidirectional Pins

PPS selections for peripherals with bidirectional signals on a single pin must be made so that the PPS input and PPS output select the same pin. Peripherals that have bidirectional signals include:

- EUSART (synchronous operation)
- MSSP (I²C)

Note: The I²C SCLx and SDAX functions can be remapped through PPS. However, only the RB1, RB2, RC3 and RC4 pins have the I²C and SMBus specific input buffers implemented (which have different thresholds compared to the normal ST/TTL input levels of the other general purpose I/O pins). If the SCLx or SDAX functions are mapped to some other pin (other than RB1, RB2, RC3 or RC4), the general purpose TTL or ST input buffers (as configured based on INLVL register setting) will be used instead. In most applications, it is therefore recommended only to map the SCLx and SDAX pin functions to the RB1, RB2, RC3 or RC4 pins.

13.4 PPS Lock

The PPS includes a mode in which all input and output selections can be locked to prevent inadvertent changes. PPS selections are locked by setting the PPSLOCKED bit of the PPSLOCK register. Setting and clearing this bit requires a special sequence as an extra precaution against inadvertent changes. Examples of setting and clearing the PPSLOCKED bit are shown in [Example 13-1](#).

EXAMPLE 13-1: PPS LOCK/UNLOCK SEQUENCE

```
; suspend interrupts
    BCF    INTCON,GIE
; BANKSEL PPSLOCK      ; set bank
; required sequence, next 5 instructions
    MOVLW 0x55
    MOVWF PPSLOCK
    MOVLW 0xAA
    MOVWF PPSLOCK
; Set PPSLOCKED bit to disable writes or
; Clear PPSLOCKED bit to enable writes
    BSF    PPSLOCK,PPSLOCKED
; restore interrupts
    BSF    INTCON,GIE
```

13.5 PPS Permanent Lock

The PPS can be permanently locked by setting the PPS1WAY Configuration bit. When this bit is set, the PPSLOCKED bit can only be cleared and set one time after a device Reset. This allows for clearing the PPSLOCKED bit so that the input and output selections can be made during initialization. When the PPSLOCKED bit is set after all selections have been made, it will remain set and cannot be cleared until after the next device Reset event.

13.6 Operation During Sleep

PPS input and output selections are unaffected by Sleep.

13.7 Effects of a Reset

A device Power-On-Reset (POR) clears all PPS input and output selections to their default values. All other Resets leave the selections unchanged. Default input selections are shown in pin allocation [Table 13-1](#) and [Table 13-2](#).

PIC16(L)F18856/76

TABLE 13-3: PPS OUTPUT SIGNAL ROUTING OPTIONS

Output Signal Name	RxyPPS Register Value	Remappable to Pins of PORTx							
		PIC16F18856			PIC16F18876				
		PORTA	PORTB	PORTC	PORTA	PORTB	PORTC	PORTD	PORTE
ADGRDG	0x25	•		•	•		•		
ADGRDA	0x24	•		•	•		•		
CWG3D	0x23	•		•	•			•	
CWG3C	0x22	•		•	•			•	
CWG3B	0x21	•		•	•				•
CWG3A	0x20		•	•		•	•		
CWG2D	0x1F		•	•		•		•	
CWG2C	0x1E		•	•		•		•	
CWG2B	0x1D		•	•		•		•	
CWG2A	0x1C		•	•		•	•		
DSM	0x1B	•		•	•			•	
CLKR	0x1A		•	•		•	•		
NCO	0x19	•		•	•			•	
TMR0	0x18		•	•		•	•		
SDO2/SDA2	0x17		•	•		•		•	
SCK2/SCL2	0x16		•	•		•		•	
SDO1/SDA1	0x15		•	•		•	•		
SCK1/SCL1	0x14		•	•		•	•		
C2OUT	0x13	•		•	•				•
C1OUT	0x12	•		•	•			•	
DT	0x11		•	•		•	•		
TX/CK	0x10		•	•		•	•		
PWM7OUT	0x0F	•		•	•		•		
PWM6OUT	0x0E	•		•	•			•	
CCP5	0x0D	•		•	•				•
CCP4	0x0C		•	•		•		•	
CCP3	0x0B		•	•		•		•	
CCP2	0x0A		•	•		•	•		
CCP1	0x09		•	•		•	•		
CWG1D	0x08		•	•		•		•	
CWG1C	0x07		•	•		•		•	
CWG1B	0x06		•	•		•		•	
CWG1A	0x05		•	•		•	•		
CLC4OUT	0x04		•	•		•		•	
CLC3OUT	0x03		•	•		•		•	
CLC2OUT	0x02	•		•	•		•		
CLC1OUT	0x01	•		•	•		•		

Note: When RxyPPS = 0x00, port pin Rxy output value is controlled by the respective LATxy bit.

PIC16(L)F18856/76

13.8 Register Definitions: PPS Input Selection

REGISTER 13-1: xxxPPS: PERIPHERAL xxx INPUT SELECTION⁽¹⁾

U-0	U-0	R/W-q/u	R/W-q/u	R/W-q/u	R/W-q/u	R/W-q/u	R/W-q/u
—	—	xxxPPS<5:0>					
bit 7							bit 0

Legend:

R = Readable bit	W = Writable bit	U = Unimplemented bit, read as '0'
u = Bit is unchanged	x = Bit is unknown	-n/n = Value at POR and BOR/Value at all other Resets
'1' = Bit is set	'0' = Bit is cleared	q = value depends on peripheral

bit 7-6 **Unimplemented:** Read as '0'
bit 5-0 **xxxPPS<5:0>:** Peripheral xxx Input Selection bits
See [Table 13-2](#).

- Note 1:** The “xxx” in the register name “xxxPPS” represents the input signal function name, such as “INT”, “TOCKI”, “RX”, etc. This register summary shown here is only a prototype of the array of actual registers, as each input function has its own dedicated SFR (ex: INTPPS, T0CKIPPS, RXPPS, etc.).
- 2:** Each specific input signal may only be mapped to a subset of these I/O pins, as shown in [Table 13-2](#). Attempting to map an input signal to a non-supported I/O pin will result in undefined behavior. For example, the “INT” signal may be mapped to any PORTA or PORTB pin. Therefore, the INTPPS register may be written with values from 0x00-0x0F (corresponding to RA0-RB7). Attempting to write 0x10 or higher to the INTPPS register is not supported and will result in undefined behavior.

PIC16(L)F18856/76

REGISTER 13-2: RxyPPS: PIN Rxy OUTPUT SOURCE SELECTION REGISTER

U-0	U-0	R/W-0/u	R/W-0/u	R/W-0/u	R/W-0/u	R/W-0/u	R/W-0/u
—	—	RxyPPS<5:0>					
bit 7							bit 0

Legend:

R = Readable bit W = Writable bit U = Unimplemented bit, read as '0'
 u = Bit is unchanged x = Bit is unknown -n/n = Value at POR and BOR/Value at all other Resets
 '1' = Bit is set '0' = Bit is cleared

bit 7-6 **Unimplemented:** Read as '0'
 bit 5-0 **RxyPPS<5:0>:** Pin Rxy Output Source Selection bits
 See [Table 13-2](#).

Note 1: TRIS control is overridden by the peripheral as required.

REGISTER 13-3: PPSLOCK: PPS LOCK REGISTER

U-0	U-0	U-0	U-0	U-0	U-0	U-0	R/W-0/0
—	—	—	—	—	—	—	PPSLOCKED
bit 7							bit 0

Legend:

R = Readable bit W = Writable bit U = Unimplemented bit, read as '0'
 u = Bit is unchanged x = Bit is unknown -n/n = Value at POR and BOR/Value at all other Resets
 '1' = Bit is set '0' = Bit is cleared

bit 7-1 **Unimplemented:** Read as '0'
 bit 0 **PPSLOCKED:** PPS Locked bit
 1= PPS is locked. PPS selections can not be changed.
 0= PPS is not locked. PPS selections can be changed.

PIC16(L)F18856/76

TABLE 13-4: SUMMARY OF REGISTERS ASSOCIATED WITH THE PPS MODULE

Name	Bit 7	Bit 6	Bit 5	Bit 4	Bit 3	Bit 2	Bit 1	Bit 0	Register on page
PPSLOCK	—	—	—	—	—	—	—	PPSLOCKED	250
INTPPS	—	—	—	—	INTPPS<3:0>				249
T0CKIPPS	—	—	—	—	T0CKIPPS<3:0>				249
T1CKIPPS	—	—	—	T1CKIPPS<4:0>				249	
T1GPPS	—	—	—	T1GPPS<4:0>				249	
T3CKIPPS	—	—	—	T3CKIPPS<4:0>				249	
T3GPPS	—	—	—	T3GPPS<4:0>				249	
T5CKIPPS	—	—	—	T5CKIPPS<4:0>				249	
T5GPPS	—	—	—	T5GPPS<4:0>				249	
T5GPPS	—	—	—	T5GPPS<4:0>				249	
T2AINPPS	—	—	—	T2AINPPS<4:0>				249	
T4AINPPS	—	—	—	T4AINPPS<4:0>				249	
T6AINPPS	—	—	—	T6AINPPS<4:0>				249	
CCP1PPS	—	—	—	CCP1PPS<4:0>				249	
CCP2PPS	—	—	—	CCP2PPS<4:0>				249	
CCP3PPS	—	—	—	CCP3PPS<4:0>				249	
CCP4PPS	—	—	—	CCP4PPS<4:0>				249	
CCP5PPS	—	—	—	CCP5PPS<4:0>				249	
CWG1PPS	—	—	—	CWG1PPS<4:0>				249	
CWG2PPS	—	—	—	CWG2PPS<4:0>				249	
CWG3PPS	—	—	—	CWG3PPS<4:0>				249	
MDCARLPPS	—	—	—	MDCARLPPS<4:0>				249	
MDCARHPPS	—	—	—	MDCARHPPS<4:0>				249	
MDSRCPPS	—	—	—	MDSRCPPS<4:0>				249	
SSP1CLKPPS	—	—	—	SSP1CLKPPS<4:0>				249	
SSP1DATPPS	—	—	—	SSP1DATPPS<4:0>				249	
SSP1SSPPS	—	—	—	SSP1SSPPS<4:0>				249	
SSP2CLKPPS	—	—	—	SSP2CLKPPS<4:0>				249	
SSP2DATPPS	—	—	—	SSP2DATPPS<4:0>				249	
SSP2SSPPS	—	—	—	SSP2SSPPS<4:0>				249	
RXPPS	—	—	—	RXPPS<4:0>				250	
TXPPS	—	—	—	TXPPS<4:0>				249	
CLCIN0PPS	—	—	—	CLCIN0PPS<4:0>				249	
CLCIN1PPS	—	—	—	CLCIN1PPS<4:0>				249	
CLCIN2PPS	—	—	—	CLCIN2PPS<4:0>				249	
CLCIN3PPS	—	—	—	CLCIN3PPS<4:0>				249	
SMT1WINPPS	—	—	—	SMT1WINPPS<4:0>				249	
SMT1SIGPPS	—	—	—	SMT1SIGPPS<4:0>				249	
SMT2WINPPS	—	—	—	SMT2WINPPS<4:0>				249	
SMT2SIGPPS	—	—	—	SMT2SIGPPS<4:0>				249	
ADCACTPPS	—	—	—	ADCACTPPS<4:0>					
RA0PPS	—	—	RA0PPS<5:0>				250		
RA1PPS	—	—	RA1PPS<5:0>				250		
RA2PPS	—	—	RA2PPS<5:0>				250		
RA3PPS	—	—	RA3PPS<5:0>				250		

Legend: — = unimplemented, read as '0'. Shaded cells are unused by the PPS module.

Note 1: PIC16F18875 only.

PIC16(L)F18856/76

TABLE 13-4: SUMMARY OF REGISTERS ASSOCIATED WITH THE PPS MODULE (CONTINUED)

Name	Bit 7	Bit 6	Bit 5	Bit 4	Bit 3	Bit 2	Bit 1	Bit 0	Register on page
RA4PPS	—	—				RA4PPS<5:0>			250
RA5PPS	—	—				RA5PPS<5:0>			250
RA6PPS	—	—				RA6PPS<5:0>			250
RA7PPS	—	—				RA7PPS<5:0>			250
RB0PPS	—	—				RB0PPS<5:0>			250
RB1PPS	—	—				RB1PPS<5:0>			250
RB2PPS	—	—				RB2PPS<5:0>			250
RB3PPS	—	—				RB3PPS<5:0>			250
RB4PPS	—	—				RB4PPS<5:0>			250
RB5PPS	—	—				RB5PPS<5:0>			250
RB6PPS	—	—				RB6PPS<5:0>			250
RB7PPS	—	—				RB7PPS<5:0>			250
RC0PPS	—	—				RC0PPS<5:0>			250
RC1PPS	—	—				RC1PPS<5:0>			250
RC2PPS	—	—				RC2PPS<5:0>			250
RC3PPS	—	—				RC3PPS<5:0>			250
RC4PPS	—	—				RC4PPS<5:0>			250
RC5PPS	—	—				RC5PPS<5:0>			250
RC6PPS	—	—				RC6PPS<5:0>			250
RC7PPS	—	—				RC7PPS<5:0>			250
RD0PPS ⁽¹⁾	—	—				RD0PPS<5:0>			250
RD1PPS ⁽¹⁾	—	—				RD1PPS<5:0>			250
RD2PPS ⁽¹⁾	—	—				RD2PPS<5:0>			250
RD3PPS ⁽¹⁾	—	—				RD3PPS<5:0>			250
RD4PPS ⁽¹⁾	—	—				RD4PPS<5:0>			250
RD5PPS ⁽¹⁾	—	—				RD5PPS<5:0>			250
RD6PPS ⁽¹⁾	—	—				RD6PPS<5:0>			250
RD7PPS ⁽¹⁾	—	—				RD7PPS<5:0>			250
RE0PPS ⁽¹⁾	—	—				RE0PPS<5:0>			250
RE1PPS ⁽¹⁾	—	—				RE1PPS<5:0>			250
RE2PPS ⁽¹⁾	—	—				RE2PPS<5:0>			250

Legend: — = unimplemented, read as '0'. Shaded cells are unused by the PPS module.

Note 1: PIC16F18875PIC16F18876 only.

PIC16(L)F18856/76

14.0 PERIPHERAL MODULE DISABLE

The PIC16F18855/75 provides the ability to disable selected modules, placing them into the lowest possible Power mode.

For legacy reasons, all modules are ON by default following any Reset.

14.1 Disabling a Module

Disabling a module has the following effects:

- All clock and control inputs to the module are suspended; there are no logic transitions, and the module will not function.
- The module is held in Reset.
- Any SFRs become “unimplemented”
 - Writing is disabled
 - Reading returns 00h
- Module outputs are disabled; I/O goes to the next module according to pin priority

14.2 Enabling a module

When the register bit is cleared, the module is re-enabled and will be in its Reset state; SFR data will reflect the POR Reset values.

Depending on the module, it may take up to one full instruction cycle for the module to become active. There should be no interaction with the module (e.g., writing to registers) for at least one instruction after it has been re-enabled.

14.3 Disabling a Module

When a module is disabled, any and all associated input selection registers (ISMs) are also disabled.

14.4 System Clock Disable

Setting SYSCMD (PMD0, [Register 14-1](#)) disables the system clock (FOSC) distribution network to the peripherals. Not all peripherals make use of SYSCLK, so not all peripherals are affected. Refer to the specific peripheral description to see if it will be affected by this bit.

PIC16(L)F18856/76

REGISTER 14-1: PMD0: PMD CONTROL REGISTER 0

R/W-0/0	R/W-0/0	U-0	R/W-0/0	R/W-0/0	R/W-0/0	R/W-0/0	R/W-0/0
SYSCMD	FVRMD	—	CRCMD	SCANMD	NVMMD	CLKRMD	IOCMD
7							0

Legend:

R = Readable bit	W = Writable bit	U = Unimplemented bit, read as '0'
u = Bit is unchanged	x = Bit is unknown	-n/n = Value at POR and BOR/Value at all other Resets
'1' = Bit is set	'0' = Bit is cleared	q = Value depends on condition

- bit 7 **SYSCMD:** Disable Peripheral System Clock Network bit
 See description in [Section 14.4 “System Clock Disable”](#).
 1 = System clock network disabled (a.k.a. Fosc)
 0 = System clock network enabled
- bit 6 **FVRMD:** Disable Fixed Voltage Reference (FVR) bit
 1 = FVR module disabled
 0 = FVR module enabled
- bit 5 **Unimplemented:** Read as '0'
- bit 4 **CRCMD:** CRC module disable bit
 1 = CRC module disabled
 0 = CRC module enabled
- bit 3 **SCANMD:** Program Memory Scanner Module Disable bit
 1 = Scanner module disabled
 0 = Scanner module enabled
- bit 2 **NVMMD:** NVM Module Disable bit⁽¹⁾
 1 = User memory and EEPROM reading and writing is disabled; NVMCON registers cannot be written;
 FSR access to these locations returns zero.
 0 = NVM module enabled
- bit 1 **CLKRMD:** Disable Clock Reference CLKR bit
 1 = CLKR module disabled
 0 = CLKR module enabled
- bit 0 **IOCMD:** Disable Interrupt-on-Change bit, All Ports
 1 = IOC module(s) disabled
 0 = IOC module(s) enabled

Note 1: When enabling NVM, a delay of up to 1 μ s may be required before accessing data.

PIC16(L)F18856/76

REGISTER 14-2: PMD1: PMD CONTROL REGISTER 1

R/W-0/0	R/W-0/0	R/W-0/0	R/W-0/0	R/W-0/0	R/W-0/0	R/W-0/0	R/W-0/0
NCOMD	TMR6MD	TMR5MD	TMR4MD	TMR3MD	TMR2MD	TMR1MD	TMR0MD
bit 7							bit 0

Legend:

R = Readable bit	W = Writable bit	U = Unimplemented bit, read as '0'
u = Bit is unchanged	x = Bit is unknown	-n/n = Value at POR and BOR/Value at all other Resets
'1' = Bit is set	'0' = Bit is cleared	q = Value depends on condition

- bit 7 **NCOMD:** Disable Numerically Control Oscillator bit
 1 = NCO1 module disabled
 0 = NCO1 module enabled
- bit 6 **TMR6MD:** Disable Timer TMR6
 1 = TMR6 module disabled
 0 = TMR6 module enabled
- bit 5 **TMR5MD:** Disable Timer TMR5
 1 = TMR5 module disabled
 0 = TMR5 module enabled
- bit 4 **TMR4MD:** Disable Timer TMR4
 1 = TMR4 module disabled
 0 = TMR4 module enabled
- bit 3 **TMR3MD:** Disable Timer TMR3
 1 = TMR3 module disabled
 0 = TMR3 module enabled
- bit 2 **TMR2MD:** Disable Timer TMR2
 1 = TMR2 module disabled
 0 = TMR2 module enabled
- bit 1 **TMR1MD:** Disable Timer TMR1
 1 = TMR1 module disabled
 0 = TMR1 module enabled
- bit 0 **TMR0MD:** Disable Timer TMR0
 1 = TMR0 module disabled
 0 = TMR0 module enabled

PIC16(L)F18856/76

REGISTER 14-3: PMD2: PMD CONTROL REGISTER 2

U-0	R/W-0/0	R/W-0/0	U-0	U-0	R/W-0/0	R/W-0/0	R/W-0/0
—	DACMD	ADCMD	—	—	CMP2MD	CMP1MD	ZCDMD
bit 7							bit 0

Legend:

R = Readable bit	W = Writable bit	U = Unimplemented bit, read as '0'
u = Bit is unchanged	x = Bit is unknown	-n/n = Value at POR and BOR/Value at all other Resets
'1' = Bit is set	'0' = Bit is cleared	q = Value depends on condition

- bit 7 **Unimplemented:** Read as '0'
- bit 6 **DACMD:** Disable DAC bit
1 = DAC module disabled
0 = DAC module enabled
- bit 5 **ADCMD:** Disable ADC bit
1 = ADC module disabled
0 = ADC module enabled
- bit 4-3 **Unimplemented:** Read as '0'
- bit 2 **CMP2MD:** Disable Comparator CMP2 bit⁽¹⁾
1 = CMP2 module disabled
0 = CMP2 module enabled
- bit 1 **CMP1MD:** Disable Comparator CMP1 bit
1 = CMP1 module disabled
0 = CMP1 module enabled
- bit 0 **ZCDMD:** Disable ZCD
1 = ZCD module disabled
0 = ZCD module enabled

PIC16(L)F18856/76

REGISTER 14-4: PMD3: PMD CONTROL REGISTER 3

U-0	R/W-0/0	R/W-0/0	R/W-0/0	R/W-0/0	R/W-0/0	R/W-0/0	R/W-0/0
—	PWM7MD	PWM6MD	CCP5MD	CCP4MD	CCP3MD	CCP2MD	CCP1MD
bit 7							bit 0

Legend:		
R = Readable bit	W = Writable bit	U = Unimplemented bit, read as '0'
u = Bit is unchanged	x = Bit is unknown	-n/n = Value at POR and BOR/Value at all other Resets
'1' = Bit is set	'0' = Bit is cleared	q = Value depends on condition

- bit 7 **Unimplemented:** Read as '0'
- bit 6 **PWM7MD:** Disable Pulse-Width Modulator PWM7 bit
1 = PWM7 module disabled
0 = PWM7 module enabled
- bit 5 **PWM6MD:** Disable Pulse-Width Modulator PWM6 bit
1 = PWM6 module disabled
0 = PWM6 module enabled
- bit 4 **CCP5MD:** Disable Pulse-Width Modulator CCP5 bit
1 = CCP5 module disabled
0 = CCP5 module enabled
- bit 3 **CCP4MD:** Disable Pulse-Width Modulator CCP4 bit
1 = CCP4 module disabled
0 = CCP4 module enabled
- bit 2 **CCP3MD:** Disable Pulse-Width Modulator CCP3 bit
1 = CCP3 module disabled
0 = CCP3 module enabled
- bit 1 **CCP2MD:** Disable Pulse-Width Modulator CCP2 bit
1 = CCP2 module disabled
0 = CCP2 module enabled
- bit 0 **CCP1MD:** Disable Pulse-Width Modulator CCP1 bit
1 = CCP1 module disabled
0 = CCP1 module enabled

PIC16(L)F18856/76

REGISTER 14-5: PMD4: PMD CONTROL REGISTER 4

U-0	R/W-0/0	R/W-0/0	R/W-0/0	U-0	R/W-0/0	R/W-0/0	R/W-0/0
—	UART1MD	MSSP2MD	MSSP1MD	—	CWG3MD	CWG2MD	CWG1MD
bit 7							bit 0

Legend:

R = Readable bit	W = Writable bit	U = Unimplemented bit, read as '0'
u = Bit is unchanged	x = Bit is unknown	-n/n = Value at POR and BOR/Value at all other Resets
'1' = Bit is set	'0' = Bit is cleared	q = Value depends on condition

- bit 7 **Unimplemented:** Read as '0'
- bit 6 **UART1MD:** Disable EUSART bit
1 = EUSART module disabled
0 = EUSART module enabled
- bit 5 **MSSP2MD:** Disable MSSP2 bit
1 = MSSP2 module disabled
0 = MSSP2 module enabled
- bit 4 **MSSP1MD:** Disable MSSP1 bit
1 = MSSP1 module disabled
0 = MSSP1 module enabled
- bit 3 **Unimplemented:** Read as '0'
- bit 2 **CWG3MD:** Disable CWG3 bit
1 = CWG3 module disabled
0 = CWG3 module enabled
- bit 1 **CWG2MD:** Disable CWG2 bit
1 = CWG2 module disabled
0 = CWG2 module enabled
- bit 0 **CWG1MD:** Disable CWG1 bit
1 = CWG1 module disabled
0 = CWG1 module enabled

PIC16(L)F18856/76

REGISTER 14-6: PMD5 – PMD CONTROL REGISTER 5

R/W-0/0	R/W-0/0	U-0	R/W-0/0	R/W-0/0	R/W-0/0	R/W-0/0	R/W-0/0
SMT2MD	SMT1MD	—	CLC4MD	CLC3MD	CLC2MD	CLC1MD	DSMMD
bit 7							bit 0

Legend:

R = Readable bit	W = Writable bit	U = Unimplemented bit, read as '0'
u = Bit is unchanged	x = Bit is unknown	-n/n = Value at POR and BOR/Value at all other Resets
'1' = Bit is set	'0' = Bit is cleared	q = Value depends on condition

- bit 7 **SMT2MD:** Disable Signal Measurement Timer2 bit
1 = SMT2 module disabled
0 = SMT2 module enabled
- bit 6 **SMT1MD:** Disable Signal Measurement Timer1 bit
1 = SMT1 module disabled
0 = SMT1 module enabled
- bit 5 **Unimplemented:** Read as '0'
- bit 4 **CLC4MD:** Disable CLC4 bit
1 = CLC4 module disabled
0 = CLC4 module enabled
- bit 3 **CLC3MD:** Disable CLC3 bit
1 = CLC3 module disabled
0 = CLC3 module enabled
- bit 2 **CLC2MD:** Disable CLC2 bit
1 = CLC2 module disabled
0 = CLC2 module enabled
- bit 1 **CLC1MD:** Disable CLC bit
1 = CLC1 module disabled
0 = CLC1 module enabled
- bit 0 **DSMMD:** Disable Data Signal Modulator bit
1 = DSM module disabled
0 = DSM module enabled

15.0 INTERRUPT-ON-CHANGE

All pins on all ports (except PORTD on PIC16F18875 devices) can be configured to operate as Interrupt-On-Change (IOC) pins. An interrupt can be generated by detecting a signal that has either a rising edge or a falling edge. Any individual pin, or combination of pins, can be configured to generate an interrupt. The interrupt-on-change module has the following features:

- Interrupt-on-Change enable (Master Switch)
- Individual pin configuration
- Rising and falling edge detection
- Individual pin interrupt flags

Figure 15-1 is a block diagram of the IOC module.

15.1 Enabling the Module

To allow individual pins to generate an interrupt, the IOCIE bit of the PIE0 register must be set. If the IOCIE bit is disabled, the edge detection on the pin will still occur, but an interrupt will not be generated.

15.2 Individual Pin Configuration

For each pin, a rising edge detector and a falling edge detector are present. To enable a pin to detect a rising edge, the associated bit of the IOCxP register is set. To enable a pin to detect a falling edge, the associated bit of the IOCxN register is set.

A pin can be configured to detect rising and falling edges simultaneously by setting the associated bits in both of the IOCxP and IOCxN registers.

15.3 Interrupt Flags

The bits located in the IOCxF registers are status flags that correspond to the interrupt-on-change pins of each port. If an expected edge is detected on an appropriately enabled pin, then the status flag for that pin will be set, and an interrupt will be generated if the IOCIE bit is set. The IOCIF bit of the PIR0 register reflects the status of all IOCxF bits.

15.4 Clearing Interrupt Flags

The individual status flags, (IOCxF register bits), can be cleared by resetting them to zero. If another edge is detected during this clearing operation, the associated status flag will be set at the end of the sequence, regardless of the value actually being written.

In order to ensure that no detected edge is lost while clearing flags, only AND operations masking out known changed bits should be performed. The following sequence is an example of what should be performed.

EXAMPLE 15-1: CLEARING INTERRUPT FLAGS (PORTA EXAMPLE)

```
MOVLW  0xff
XORWF  IOCAF, W
ANDWF  IOCAF, F
```

15.5 Operation in Sleep

The interrupt-on-change interrupt sequence will wake the device from Sleep mode, if the IOCIE bit is set.

If an edge is detected while in Sleep mode, the affected IOCxF register will be updated prior to the first instruction executed out of Sleep.

PIC16(L)F18856/76

FIGURE 15-1: INTERRUPT-ON-CHANGE BLOCK DIAGRAM (PORTA EXAMPLE)

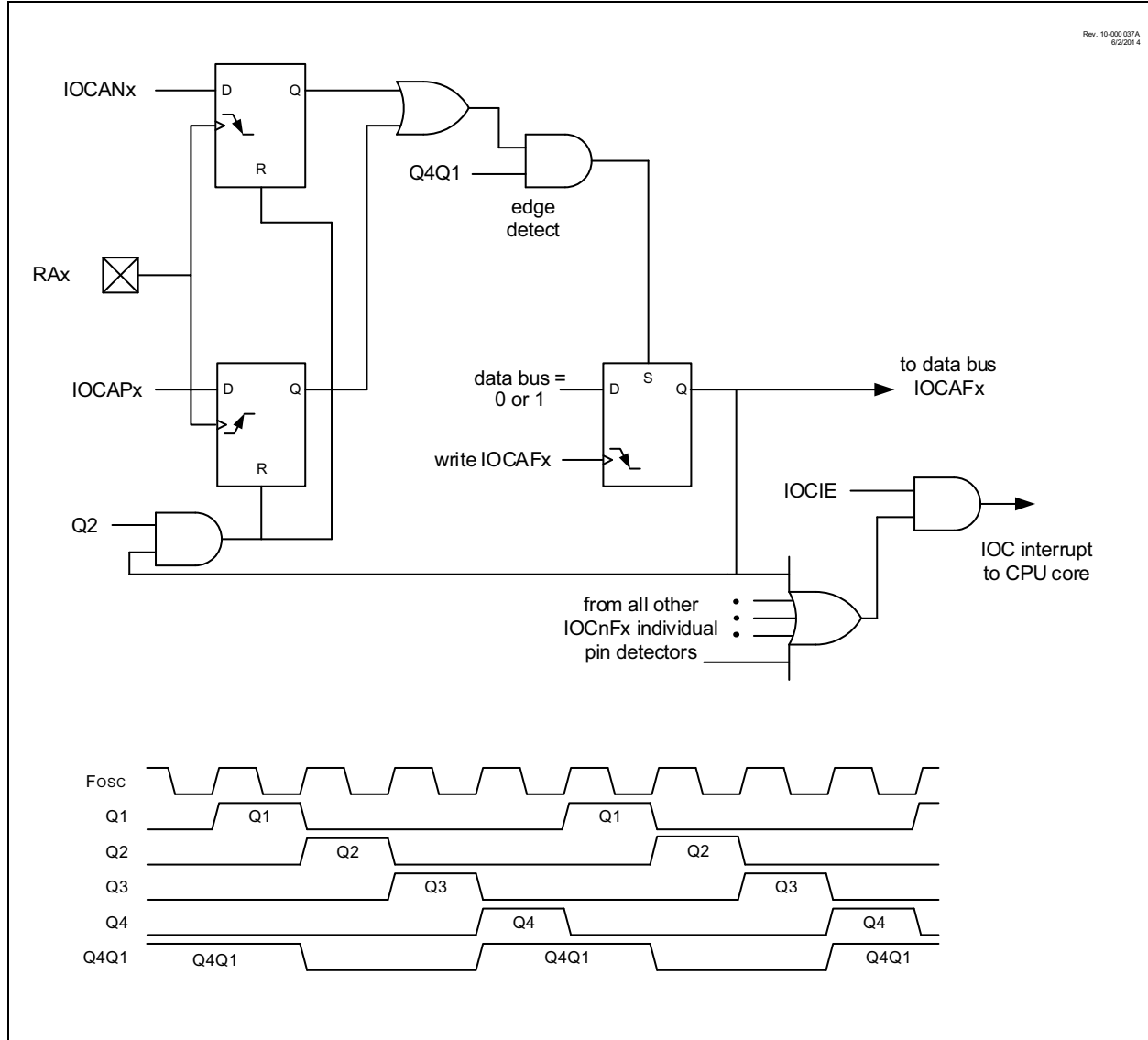

PIC16(L)F18856/76

15.6 Register Definitions: Interrupt-on-Change Control

REGISTER 15-1: IOCAP: INTERRUPT-ON-CHANGE PORTA POSITIVE EDGE REGISTER

R/W-0/0	R/W-0/0	R/W-0/0	R/W-0/0	R/W-0/0	R/W-0/0	R/W-0/0	R/W-0/0
IOCAP7	IOCAP6	IOCAP5	IOCAP4	IOCAP3	IOCAP2	IOCAP1	IOCAP0
bit 7							bit 0

Legend:

R = Readable bit W = Writable bit U = Unimplemented bit, read as '0'
u = Bit is unchanged x = Bit is unknown -n/n = Value at POR and BOR/Value at all other Resets
'1' = Bit is set '0' = Bit is cleared

bit 7-0 **IOCAP<7:0>**: Interrupt-on-Change PORTA Positive Edge Enable bits
1 = Interrupt-on-Change enabled on the pin for a positive-going edge. IOCAF_x bit and IOCIF flag will be set upon detecting an edge.
0 = Interrupt-on-Change disabled for the associated pin.

REGISTER 15-2: IOCAN: INTERRUPT-ON-CHANGE PORTA NEGATIVE EDGE REGISTER

R/W-0/0	R/W-0/0	R/W-0/0	R/W-0/0	R/W-0/0	R/W-0/0	R/W-0/0	R/W-0/0
IOCAN7	IOCAN6	IOCAN5	IOCAN4	IOCAN3	IOCAN2	IOCAN1	IOCAN0
bit 7							bit 0

Legend:

R = Readable bit W = Writable bit U = Unimplemented bit, read as '0'
u = Bit is unchanged x = Bit is unknown -n/n = Value at POR and BOR/Value at all other Resets
'1' = Bit is set '0' = Bit is cleared

bit 7-0 **IOCAN<7:0>**: Interrupt-on-Change PORTA Negative Edge Enable bits
1 = Interrupt-on-Change enabled on the pin for a negative-going edge. IOCAF_x bit and IOCIF flag will be set upon detecting an edge.
0 = Interrupt-on-Change disabled for the associated pin.

REGISTER 15-3: IOCAF: INTERRUPT-ON-CHANGE PORTA FLAG REGISTER

R/W/HS-0/0	R/W/HS-0/0	R/W/HS-0/0	R/W/HS-0/0	R/W/HS-0/0	R/W/HS-0/0	R/W/HS-0/0	R/W/HS-0/0
IOCAF7	IOCAF6	IOCAF5	IOCAF4	IOCAF3	IOCAF2	IOCAF1	IOCAF0
bit 7							bit 0

Legend:

R = Readable bit W = Writable bit U = Unimplemented bit, read as '0'
u = Bit is unchanged x = Bit is unknown -n/n = Value at POR and BOR/Value at all other Resets
'1' = Bit is set '0' = Bit is cleared HS - Bit is set in hardware

bit 7-0 **IOCAF<7:0>**: Interrupt-on-Change PORTA Flag bits
1 = An enabled change was detected on the associated pin.
Set when IOCAP_x = 1 and a rising edge was detected on RAX, or when IOCAN_x = 1 and a falling edge was detected on RAX.
0 = No change was detected, or the user cleared the detected change.

PIC16(L)F18856/76

REGISTER 15-4: IOCBP: INTERRUPT-ON-CHANGE PORTB POSITIVE EDGE REGISTER

R/W-0/0	R/W-0/0	R/W-0/0	R/W-0/0	R/W-0/0	R/W-0/0	R/W-0/0	R/W-0/0
IOCBP7	IOCBP6	IOCBP5	IOCBP4	IOCBP3	IOCBP2	IOCBP1	IOCBP0
bit 7							bit 0

Legend:

R = Readable bit	W = Writable bit	U = Unimplemented bit, read as '0'
u = Bit is unchanged	x = Bit is unknown	-n/n = Value at POR and BOR/Value at all other Resets
'1' = Bit is set	'0' = Bit is cleared	

bit 7-0 **IOCBP<7:0>**: Interrupt-on-Change PORTB Positive Edge Enable bits
 1 = Interrupt-on-Change enabled on the pin for a positive-going edge. IOCBFx bit and IOCIF flag will be set upon detecting an edge.
 0 = Interrupt-on-Change disabled for the associated pin.

REGISTER 15-5: IOCBN: INTERRUPT-ON-CHANGE PORTB NEGATIVE EDGE REGISTER

R/W-0/0	R/W-0/0	R/W-0/0	R/W-0/0	R/W-0/0	R/W-0/0	R/W-0/0	R/W-0/0
IOCBN7	IOCBN6	IOCBN5	IOCBN4	IOCBN3	IOCBN2	IOCBN1	IOCBN0
bit 7							bit 0

Legend:

R = Readable bit	W = Writable bit	U = Unimplemented bit, read as '0'
u = Bit is unchanged	x = Bit is unknown	-n/n = Value at POR and BOR/Value at all other Resets
'1' = Bit is set	'0' = Bit is cleared	

bit 7-0 **IOCBN<7:0>**: Interrupt-on-Change PORTB Negative Edge Enable bits
 1 = Interrupt-on-Change enabled on the pin for a negative-going edge. IOCBFx bit and IOCIF flag will be set upon detecting an edge.
 0 = Interrupt-on-Change disabled for the associated pin.

REGISTER 15-6: IOCBF: INTERRUPT-ON-CHANGE PORTB FLAG REGISTER

R/W/HS-0/0	R/W/HS-0/0	R/W/HS-0/0	R/W/HS-0/0	R/W/HS-0/0	R/W/HS-0/0	R/W/HS-0/0	R/W/HS-0/0
IOCBF7	IOCBF6	IOCBF5	IOCBF4	IOCBF3	IOCBF2	IOCBF1	IOCBF0
bit 7							bit 0

Legend:

R = Readable bit	W = Writable bit	U = Unimplemented bit, read as '0'
u = Bit is unchanged	x = Bit is unknown	-n/n = Value at POR and BOR/Value at all other Resets
'1' = Bit is set	'0' = Bit is cleared	HS - Bit is set in hardware

bit 7-0 **IOCBF<7:0>**: Interrupt-on-Change PORTB Flag bits
 1 = An enabled change was detected on the associated pin.
 Set when IOCBPx = 1 and a rising edge was detected on RBx, or when IOCBNx = 1 and a falling edge was detected on RBx.
 0 = No change was detected, or the user cleared the detected change.

PIC16(L)F18856/76

REGISTER 15-7: IOCCP: INTERRUPT-ON-CHANGE PORTC POSITIVE EDGE REGISTER

R/W-0/0	R/W-0/0	R/W-0/0	R/W-0/0	R/W-0/0	R/W-0/0	R/W-0/0	R/W-0/0
IOCCP7	IOCCP6	IOCCP5	IOCCP4	IOCCP3	IOCCP2	IOCCP1	IOCCP0
bit 7							bit 0

Legend:

R = Readable bit W = Writable bit U = Unimplemented bit, read as '0'
u = Bit is unchanged x = Bit is unknown -n/n = Value at POR and BOR/Value at all other Resets
'1' = Bit is set '0' = Bit is cleared

bit 7-0 **IOCCP<7:0>**: Interrupt-on-Change PORTC Positive Edge Enable bits
1 = Interrupt-on-Change enabled on the pin for a positive-going edge. IOCCFx bit and IOCIF flag will be set upon detecting an edge.
0 = Interrupt-on-Change disabled for the associated pin

REGISTER 15-8: IOCCN: INTERRUPT-ON-CHANGE PORTC NEGATIVE EDGE REGISTER

R/W-0/0	R/W-0/0	R/W-0/0	R/W-0/0	R/W-0/0	R/W-0/0	R/W-0/0	R/W-0/0
IOCCN7	IOCCN6	IOCCN5	IOCCN4	IOCCN3	IOCCN2	IOCCN1	IOCCN0
bit 7							bit 0

Legend:

R = Readable bit W = Writable bit U = Unimplemented bit, read as '0'
u = Bit is unchanged x = Bit is unknown -n/n = Value at POR and BOR/Value at all other Resets
'1' = Bit is set '0' = Bit is cleared

bit 7-0 **IOCCN<7:0>**: Interrupt-on-Change PORTC Negative Edge Enable bits
1 = Interrupt-on-Change enabled on the pin for a negative-going edge. IOCCFx bit and IOCIF flag will be set upon detecting an edge.
0 = Interrupt-on-Change disabled for the associated pin

REGISTER 15-9: IOCCF: INTERRUPT-ON-CHANGE PORTC FLAG REGISTER

R/W/HS-0/0	R/W/HS-0/0	R/W/HS-0/0	R/W/HS-0/0	R/W/HS-0/0	R/W/HS-0/0	R/W/HS-0/0	R/W/HS-0/0
IOCCF7	IOCCF6	IOCCF5	IOCCF4	IOCCF3	IOCCF2	IOCCF1	IOCCF0
bit 7							bit 0

Legend:

R = Readable bit W = Writable bit U = Unimplemented bit, read as '0'
u = Bit is unchanged x = Bit is unknown -n/n = Value at POR and BOR/Value at all other Resets
'1' = Bit is set '0' = Bit is cleared HS - Bit is set in hardware

bit 7-0 **IOCCF<7:0>**: Interrupt-on-Change PORTC Flag bits
1 = An enabled change was detected on the associated pin
Set when IOCCPx = 1 and a rising edge was detected on RCx, or when IOCCNx = 1 and a falling edge was detected on RCx.
0 = No change was detected, or the user cleared the detected change

PIC16(L)F18856/76

REGISTER 15-10: IOCEP: INTERRUPT-ON-CHANGE PORTE POSITIVE EDGE REGISTER

U-0	U-0	U-0	U-0	R/W/HS-0/0	U-0	U-0	U-0
—	—	—	—	IOCEP3	—	—	—
bit 7				bit 0			

Legend:

R = Readable bit	W = Writable bit	U = Unimplemented bit, read as '0'
u = Bit is unchanged	x = Bit is unknown	-n/n = Value at POR and BOR/Value at all other Resets
'1' = Bit is set	'0' = Bit is cleared	HS - Bit is set in hardware

bit 7-4 **Unimplemented:** Read as '0'

bit 3 **IOCEP3:** Interrupt-on-Change PORTE Positive Edge Enable bit
 1 = Interrupt-on-Change enabled on the pin for a positive-going edge. IOCCFx bit and IOCIF flag will be set upon detecting an edge.
 0 = Interrupt-on-Change disabled for the associated pin

bit 2-0 **Unimplemented:** Read as '0'

REGISTER 15-11: IOCEN: INTERRUPT-ON-CHANGE PORTE NEGATIVE EDGE REGISTER

U-0	U-0	U-0	U-0	R/W/HS-0/0	U-0	U-0	U-0
—	—	—	—	IOCEN3	—	—	—
bit 7				bit 0			

Legend:

R = Readable bit	W = Writable bit	U = Unimplemented bit, read as '0'
u = Bit is unchanged	x = Bit is unknown	-n/n = Value at POR and BOR/Value at all other Resets
'1' = Bit is set	'0' = Bit is cleared	HS - Bit is set in hardware

bit 7-4 **Unimplemented:** Read as '0'

bit 3 **IOCEN3:** Interrupt-on-Change PORTE Negative Edge Enable bit
 1 = Interrupt-on-Change enabled on the pin for a negative-going edge. IOCCFx bit and IOCIF flag will be set upon detecting an edge.
 0 = Interrupt-on-Change disabled for the associated pin

bit 2-0 **Unimplemented:** Read as '0'

PIC16(L)F18856/76

REGISTER 15-12: IOCEF: INTERRUPT-ON-CHANGE PORTE FLAG REGISTER

U-0	U-0	U-0	U-0	R/W/HS-0/0	U-0	U-0	U-0
—	—	—	—	IOCEF3	—	—	—
bit 7							bit 0

Legend:

R = Readable bit	W = Writable bit	U = Unimplemented bit, read as '0'
u = Bit is unchanged	x = Bit is unknown	-n/n = Value at POR and BOR/Value at all other Resets
'1' = Bit is set	'0' = Bit is cleared	HS - Bit is set in hardware

bit 7-4 **Unimplemented:** Read as '0'

bit 3 **IOCEF3:** Interrupt-on-Change PORTE Flag bit
 1 = An enabled change was detected on the associated pin
 Set when IOCCPx = 1 and a rising edge was detected on RCx, or when IOCCNx = 1 and a falling edge was detected on RCx.
 0 = No change was detected, or the user cleared the detected change

bit 2-0 **Unimplemented:** Read as '0'

PIC16(L)F18856/76

TABLE 15-1: SUMMARY OF REGISTERS ASSOCIATED WITH INTERRUPT-ON-CHANGE

Name	Bit 7	Bit 6	Bit 5	Bit 4	Bit 3	Bit 2	Bit 1	Bit 0	Register on Page
ANSELA	ANSA7	ANSA6	ANSA4	ANSA4	ANSA3	ANSA2	ANSA1	ANSA0	205
ANSELC	ANSC7	ANSC6	ANSC5	ANSC4	ANSC3	ANSC2	ANSC1	ANSC0	221
TRISA	TRISA7	TRISA6	TRISA5	TRISA4	TRISA3	TRISA2	TRISA1	TRISA0	204
TRISC	TRISC7	TRISC6	TRISC5	TRISC4	TRISC3	TRISC2	TRISC1	TRISC0	220
INTCON	GIE	PEIE	—	—	—	—	—	INTEDG	134
PIE0	—	—	TMR0IE	IOCE	—	—	—	INTE	135
IOCAP	IOCAP7	IOCAP6	IOCAP5	IOCAP4	IOCAP3	IOCAP2	IOCAP1	IOCAP0	262
IOCAN	IOCAN7	IOCAN6	IOCAN5	IOCAN4	IOCAN3	IOCAN2	IOCAN1	IOCAN0	262
IOCAF	IOCAF7	IOCAF6	IOCAF5	IOCAF4	IOCAF3	IOCAF2	IOCAF1	IOCAF0	262
IOCBP	IOCBP7	IOCBP6	IOCBP5	IOCBP4	IOCBP3	IOCBP2	IOCBP1	IOCBP0	263
IOCBN	IOCBN7	IOCBN6	IOCBN5	IOCBN4	IOCBN3	IOCBN2	IOCBN1	IOCBN0	263
IOCBF	IOCBF7	IOCBF6	IOCBF5	IOCBF4	IOCBF3	IOCBF2	IOCBF1	IOCBF0	263
IOCCP	IOCCP7	IOCCP6	IOCCP5	IOCCP4	IOCCP3	IOCCP2	IOCCP1	IOCCP0	264
IOCCN	IOCCN7	IOCCN6	IOCCN5	IOCCN4	IOCCN3	IOCCN2	IOCCN1	IOCCN0	264
IOCCF	IOCCF7	IOCCF6	IOCCF5	IOCCF4	IOCCF3	IOCCF2	IOCCF1	IOCCF0	264
IOCEP	—	—	—	—	IOCEP3	—	—	—	265
IOCEN	—	—	—	—	IOCEN3	—	—	—	265
IOCEF	—	—	—	—	IOCEF3	—	—	—	266

Legend: — = unimplemented location, read as '0'. Shaded cells are not used by interrupt-on-change.

PIC16(L)F18856/76

16.0 FIXED VOLTAGE REFERENCE (FVR)

The Fixed Voltage Reference, or FVR, is a stable voltage reference, independent of V_{DD} , with 1.024V, 2.048V or 4.096V selectable output levels. The output of the FVR can be configured to supply a reference voltage to the following:

- ADC input channel
- ADC positive reference
- Comparator positive input
- Digital-to-Analog Converter (DAC)

The FVR can be enabled by setting the FVREN bit of the FVRCON register.

Note: Fixed Voltage Reference output cannot exceed V_{DD} .

16.1 Independent Gain Amplifiers

The output of the FVR, which is connected to the ADC, comparators, and DAC, is routed through two independent programmable gain amplifiers. Each amplifier can be programmed for a gain of 1x, 2x or 4x, to produce the three possible voltage levels.

The ADFVR<1:0> bits of the FVRCON register are used to enable and configure the gain amplifier settings for the reference supplied to the ADC module. Reference [Section 23.0 “Analog-to-Digital Converter With Computation \(ADC2\) Module”](#) for additional information.

The CDAFVR<1:0> bits of the FVRCON register are used to enable and configure the gain amplifier settings for the reference supplied to the DAC and comparator module. Reference [Section 25.0 “5-Bit Digital-to-Analog Converter \(DAC1\) Module”](#) and [Section 18.0 “Comparator Module”](#) for additional information.

16.2 FVR Stabilization Period

When the Fixed Voltage Reference module is enabled, it requires time for the reference and amplifier circuits to stabilize. Once the circuits stabilize and are ready for use, the FVRRDY bit of the FVRCON register will be set.

FIGURE 16-1: VOLTAGE REFERENCE BLOCK DIAGRAM

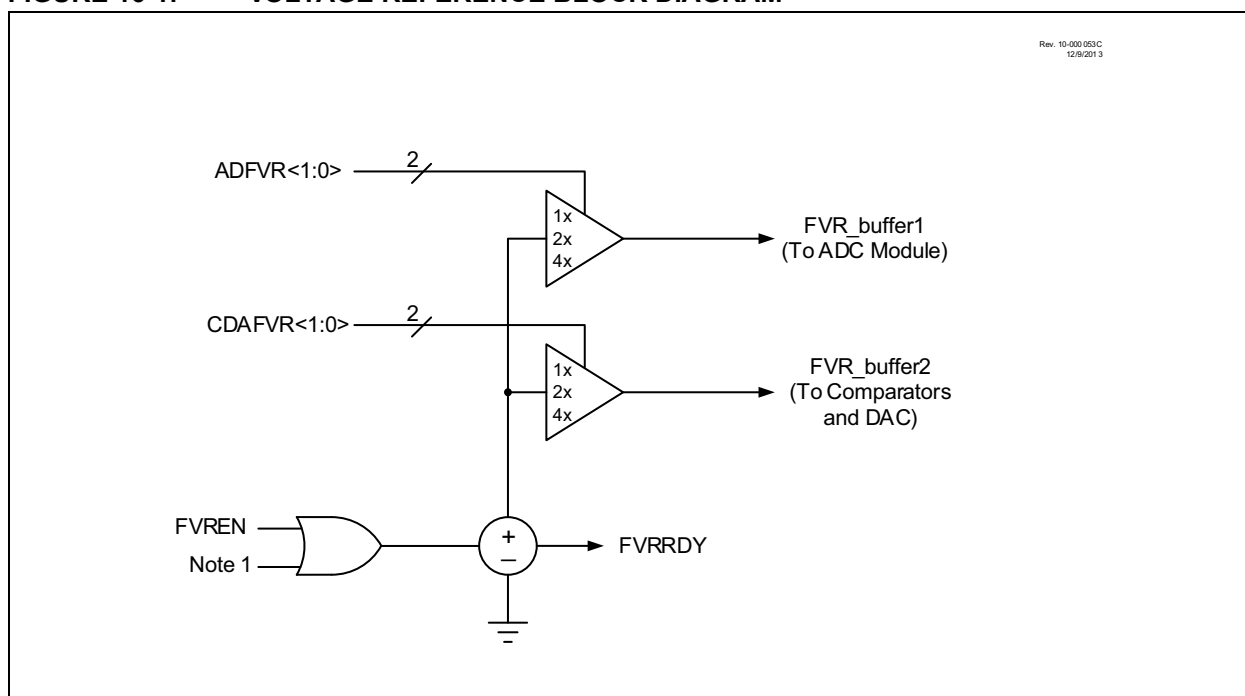

PIC16(L)F18856/76

16.3 Register Definitions: FVR Control

REGISTER 16-1: FVRCON: FIXED VOLTAGE REFERENCE CONTROL REGISTER

R/W-0/0	R-q/q	R/W-0/0	R/W-0/0	R/W-0/0	R/W-0/0	R/W-0/0	R/W-0/0
FVREN	FVRRDY ⁽¹⁾	TSEN ⁽³⁾	TSRNG ⁽³⁾	CDAFVR<1:0>		ADFVR<1:0>	
bit 7						bit 0	

Legend:

R = Readable bit	W = Writable bit	U = Unimplemented bit, read as '0'
u = Bit is unchanged	x = Bit is unknown	-n/n = Value at POR and BOR/Value at all other Resets
'1' = Bit is set	'0' = Bit is cleared	q = Value depends on condition

bit 7	FVREN: Fixed Voltage Reference Enable bit 1 = Fixed Voltage Reference is enabled 0 = Fixed Voltage Reference is disabled
bit 6	FVRRDY: Fixed Voltage Reference Ready Flag bit ⁽¹⁾ 1 = Fixed Voltage Reference output is ready for use 0 = Fixed Voltage Reference output is not ready or not enabled
bit 5	TSEN: Temperature Indicator Enable bit ⁽³⁾ 1 = Temperature Indicator is enabled 0 = Temperature Indicator is disabled
bit 4	TSRNG: Temperature Indicator Range Selection bit ⁽³⁾ 1 = VOUT = VDD - 4VT (High Range) 0 = VOUT = VDD - 2VT (Low Range)
bit 3-2	CDAFVR<1:0>: Comparator FVR Buffer Gain Selection bits 11 = Comparator FVR Buffer Gain is 4x, (4.096V) ⁽²⁾ 10 = Comparator FVR Buffer Gain is 2x, (2.048V) ⁽²⁾ 01 = Comparator FVR Buffer Gain is 1x, (1.024V) 00 = Comparator FVR Buffer is off
bit 1-0	ADFVR<1:0>: ADC FVR Buffer Gain Selection bit 11 = ADC FVR Buffer Gain is 4x, (4.096V) ⁽²⁾ 10 = ADC FVR Buffer Gain is 2x, (2.048V) ⁽²⁾ 01 = ADC FVR Buffer Gain is 1x, (1.024V) 00 = ADC FVR Buffer is off

- Note 1:** FVRRDY is always '1' for PIC16F18855/75 devices only.
Note 2: Fixed Voltage Reference output cannot exceed VDD.
Note 3: See [Section 17.0 "Temperature Indicator Module"](#) for additional information.

PIC16(L)F18856/76

TABLE 16-1: SUMMARY OF REGISTERS ASSOCIATED WITH FIXED VOLTAGE REFERENCE

Name	Bit 7	Bit 6	Bit 5	Bit 4	Bit 3	Bit 2	Bit 1	Bit 0	Register on page
FVRCON	FVREN	FVRRDY	TSEN	TSRNG	CDAFVR<1:0>		ADFVR<1:0>		269
ADREF				ADNREF			ADPREF<1:0>		362
ADPCH			ADPCH<5:0>						363
CM1CON1	—	—	—	—	—	—	INTP	INTN	280
CM1NSEL	—	—	—	—	—	NCH<2:0>			281
CM1PSEL	—	—	—	—	—	PCH<2:0>			281
CM2CON1	—	—	—	—	—	—	INTP	INTN	280
CM2NSEL	—	—	—	—	—	NCH<2:0>			281
CM2PSEL	—	—	—	—	—	PCH<2:0>			281
DAC1CON0	DAC1EN	—	DAC1OE1	DAC1OE2	DAC1PSS<1:0>		—	DAC1NSS	389

Legend: — = unimplemented locations read as '0'. Shaded cells are not used with the Fixed Voltage Reference.

PIC16(L)F18856/76

17.0 TEMPERATURE INDICATOR MODULE

This family of devices is equipped with a temperature circuit designed to measure the operating temperature of the silicon die. The circuit's range of operating temperature falls between -40°C and $+85^{\circ}\text{C}$. The output is a voltage that is proportional to the device temperature. The output of the temperature indicator is internally connected to the device ADC.

The circuit may be used as a temperature threshold detector or a more accurate temperature indicator, depending on the level of calibration performed. A one-point calibration allows the circuit to indicate a temperature closely surrounding that point. A two-point calibration allows the circuit to sense the entire range of temperature more accurately. Reference Application Note AN1333, "Use and Calibration of the Internal Temperature Indicator" (DS01333) for more details regarding the calibration process.

17.1 Circuit Operation

Figure 17-1 shows a simplified block diagram of the temperature circuit. The proportional voltage output is achieved by measuring the forward voltage drop across multiple silicon junctions.

Equation 17-1 describes the output characteristics of the temperature indicator.

EQUATION 17-1: V_{OUT} RANGES

High Range: $V_{\text{OUT}} = V_{\text{DD}} - 4V_{\text{T}}$

Low Range: $V_{\text{OUT}} = V_{\text{DD}} - 2V_{\text{T}}$

The temperature sense circuit is integrated with the Fixed Voltage Reference (FVR) module. See [16.0 "Fixed Voltage Reference \(FVR\)"](#) for more information.

The circuit is enabled by setting the TSEN bit of the FVRCON register. When disabled, the circuit draws no current.

The circuit operates in either high or low range. The high range, selected by setting the TSRNG bit of the FVRCON register, provides a wider output voltage. This provides more resolution over the temperature range, but may be less consistent from part to part. This range requires a higher bias voltage to operate and thus, a higher V_{DD} is needed.

The low range is selected by clearing the TSRNG bit of the FVRCON register. The low range generates a lower voltage drop and thus, a lower bias voltage is needed to operate the circuit. The low range is provided for low voltage operation.

FIGURE 17-1: TEMPERATURE CIRCUIT DIAGRAM

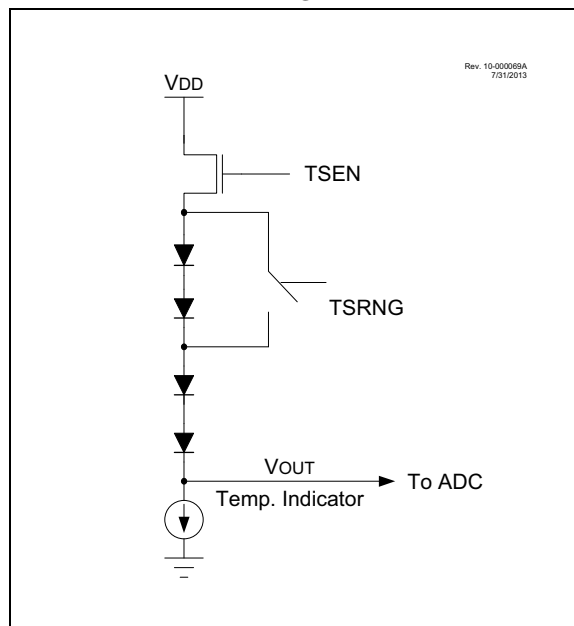

17.2 Minimum Operating V_{DD}

When the temperature circuit is operated in low range, the device may be operated at any operating voltage that is within specifications.

When the temperature circuit is operated in high range, the device operating voltage, V_{DD} , must be high enough to ensure that the temperature circuit is correctly biased.

Table 17-1 shows the recommended minimum V_{DD} vs. range setting.

TABLE 17-1: RECOMMENDED V_{DD} VS. RANGE

Min. V_{DD} , TSRNG = 1	Min. V_{DD} , TSRNG = 0
3.6V	1.8V

17.3 Temperature Output

The output of the circuit is measured using the internal Analog-to-Digital Converter. A channel is reserved for the temperature circuit output. Refer to [Section 23.0 "Analog-to-Digital Converter With Computation \(ADC2\) Module"](#) for detailed information.

PIC16(L)F18856/76

17.4 ADC Acquisition Time

To ensure accurate temperature measurements, the user must wait at least 200 μ s after the ADC input multiplexer is connected to the temperature indicator output before the conversion is performed. In addition, the user must wait 200 μ s between consecutive conversions of the temperature indicator output.

TABLE 17-2: SUMMARY OF REGISTERS ASSOCIATED WITH THE TEMPERATURE INDICATOR

Name	Bit 7	Bit 6	Bit 5	Bit 4	Bit 3	Bit 2	Bit 1	Bit 0	Register on page
FVRCON	FVREN	FVRRDY	TSEN	TSRNG	CDFVR<1:0>	ADFVR<1:0>			269

Legend: Shaded cells are unused by the Temperature Indicator module.

PIC16(L)F18856/76

18.0 COMPARATOR MODULE

Comparators are used to interface analog circuits to a digital circuit by comparing two analog voltages and providing a digital indication of their relative magnitudes. Comparators are very useful mixed signal building blocks because they provide analog functionality independent of program execution. The analog comparator module includes the following features:

- Programmable input selection
- Programmable output polarity
- Rising/falling output edge interrupts
- Wake-up from Sleep
- Programmable Speed/Power optimization
- CWG1 Auto-shutdown source
- Selectable voltage reference

18.1 Comparator Overview

A single comparator is shown in [Figure 18-1](#) along with the relationship between the analog input levels and the digital output. When the analog voltage at V_{IN+} is less than the analog voltage at V_{IN-} , the output of the comparator is a digital low level. When the analog voltage at V_{IN+} is greater than the analog voltage at V_{IN-} , the output of the comparator is a digital high level.

The comparators available are shown in [Table 18-1](#).

TABLE 18-1: AVAILABLE COMPARATORS

Device	C1	C2	C3	C4	C5
PIC16(L)F18856/76	•	•	•	•	•
PIC16(L)F18856/76					

FIGURE 18-1: SINGLE COMPARATOR

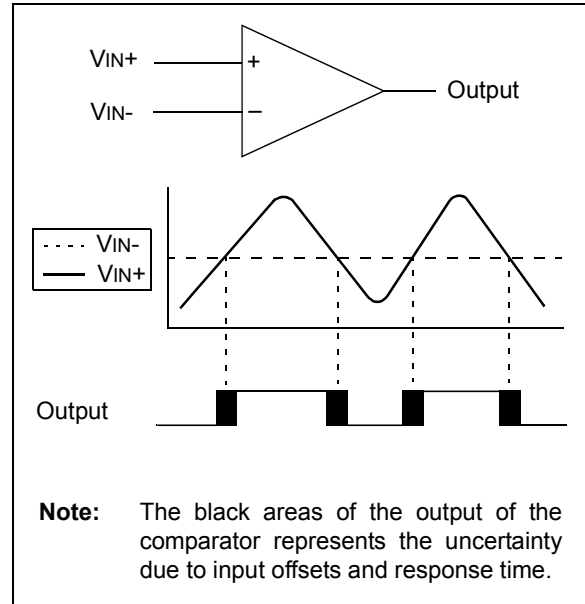

PIC16(L)F18856/76

FIGURE 18-2: COMPARATOR MODULE SIMPLIFIED BLOCK DIAGRAM

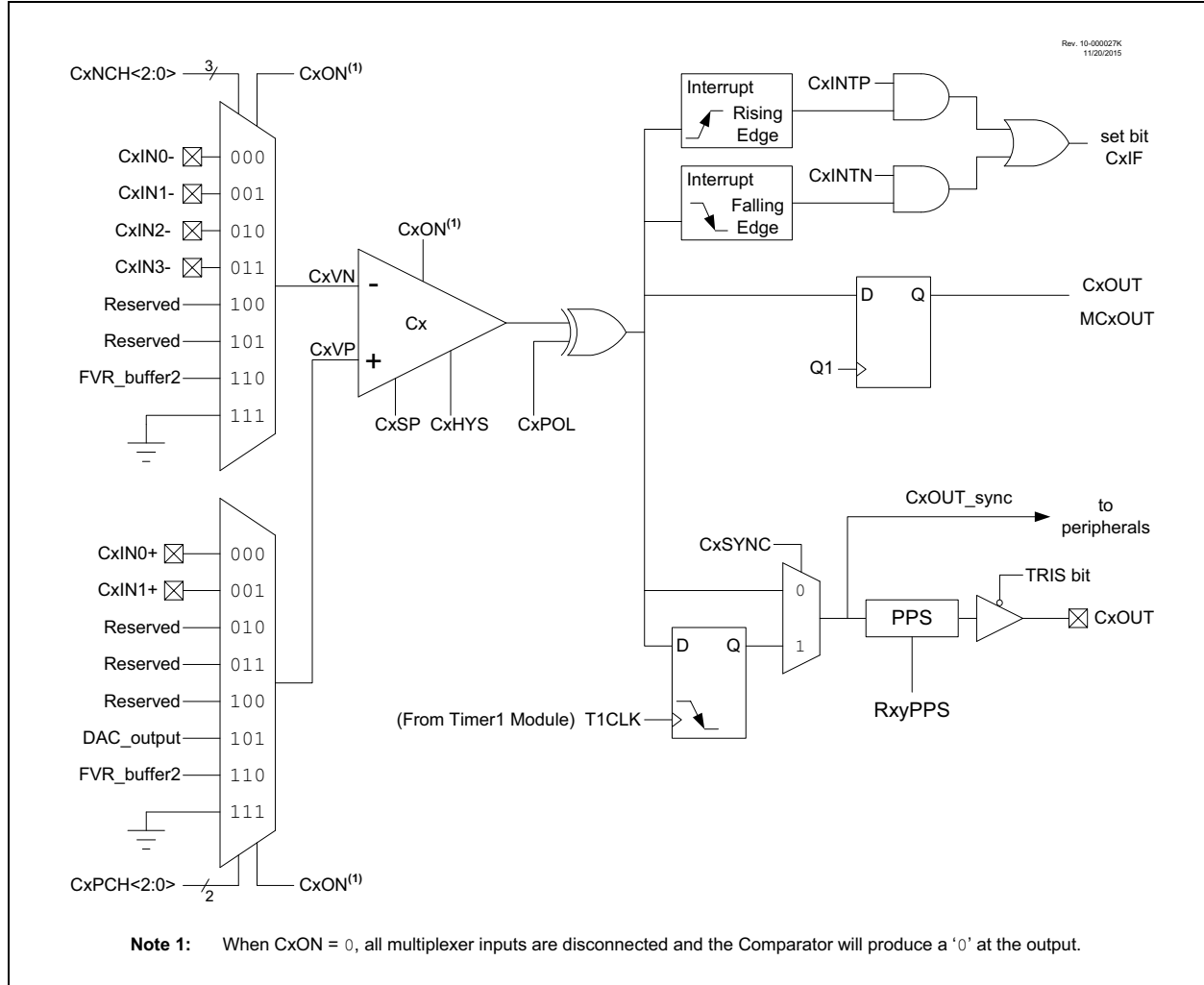

PIC16(L)F18856/76

18.2 Comparator Control

Each comparator has two control registers: CMxCON0 and CMxCON1.

The CMxCON0 register (see [Register 18-1](#)) contains Control and Status bits for the following:

- Enable
- Output
- Output polarity
- Speed/Power selection
- Hysteresis enable
- Timer1 output synchronization

The CMxCON1 register (see [Register 18-2](#)) contains Control bits for the following:

- Interrupt on positive/negative edge enables
- Positive input channel selection
- Negative input channel selection

18.2.1 COMPARATOR ENABLE

Setting the CxON bit of the CMxCON0 register enables the comparator for operation. Clearing the CxON bit disables the comparator resulting in minimum current consumption.

18.2.2 COMPARATOR OUTPUT

The output of the comparator can be monitored by reading either the CxOUT bit of the CMxCON0 register or the MCxOUT bit of the CMOUT register.

The comparator output can also be routed to an external pin through the RxyPPS register ([Register 13-2](#)). The corresponding TRIS bit must be clear to enable the pin as an output.

Note 1: The internal output of the comparator is latched with each instruction cycle. Unless otherwise specified, external outputs are not latched.

18.2.3 COMPARATOR OUTPUT POLARITY

Inverting the output of the comparator is functionally equivalent to swapping the comparator inputs. The polarity of the comparator output can be inverted by setting the CxPOL bit of the CMxCON0 register. Clearing the CxPOL bit results in a non-inverted output.

[Table 18-2](#) shows the output state versus input conditions, including polarity control.

TABLE 18-2: COMPARATOR OUTPUT STATE VS. INPUT CONDITIONS

Input Condition	CxPOL	CxOUT
$CxVN > CxVP$	0	0
$CxVN < CxVP$	0	1
$CxVN > CxVP$	1	1
$CxVN < CxVP$	1	0

18.3 Comparator Hysteresis

A selectable amount of separation voltage can be added to the input pins of each comparator to provide a hysteresis function to the overall operation. Hysteresis is enabled by setting the CxHYS bit of the CMxCON0 register.

See Comparator Specifications in [Table 37-14](#) for more information.

18.4 Timer1 Gate Operation

The output resulting from a comparator operation can be used as a source for gate control of Timer1. See [Section 28.7 “Timer Gate”](#) for more information. This feature is useful for timing the duration or interval of an analog event.

It is recommended that the comparator output be synchronized to Timer1. This ensures that Timer1 does not increment while a change in the comparator is occurring.

18.4.1 COMPARATOR OUTPUT SYNCHRONIZATION

The output from a comparator can be synchronized with Timer1 by setting the CxSYNC bit of the CMxCON0 register.

Once enabled, the comparator output is latched on the falling edge of the Timer1 source clock. If a prescaler is used with Timer1, the comparator output is latched after the prescaling function. To prevent a race condition, the comparator output is latched on the falling edge of the Timer1 clock source and Timer1 increments on the rising edge of its clock source. See the Comparator Block Diagram ([Figure 18-2](#)) and the Timer1 Block Diagram ([Figure 28-1](#)) for more information.

18.5 Comparator Interrupt

An interrupt can be generated upon a change in the output value of the comparator for each comparator, a rising edge detector and a falling edge detector are present.

When either edge detector is triggered and its associated enable bit is set (CxINTP and/or CxINTN bits of the CMxCON1 register), the Corresponding Interrupt Flag bit (CxIF bit of the PIR2 register) will be set.

To enable the interrupt, you must set the following bits:

- CxON, CxPOL and CxSP bits of the CMxCON0 register
- CxIE bit of the PIE2 register
- CxINTP bit of the CMxCON1 register (for a rising edge detection)
- CxINTN bit of the CMxCON1 register (for a falling edge detection)
- PEIE and GIE bits of the INTCON register

The associated interrupt flag bit, CxIF bit of the PIR2 register, must be cleared in software. If another edge is detected while this flag is being cleared, the flag will still be set at the end of the sequence.

Note: Although a comparator is disabled, an interrupt can be generated by changing the output polarity with the CxPOL bit of the CMxCON0 register, or by switching the comparator on or off with the CxON bit of the CMxCON0 register.

18.6 Comparator Positive Input Selection

Configuring the CxPCH<2:0> bits of the CMxCON1 register directs an internal voltage reference or an analog pin to the non-inverting input of the comparator:

- CxIN0+ analog pin
- DAC output
- FVR (Fixed Voltage Reference)
- Vss (Ground)

See [Section 16.0 “Fixed Voltage Reference \(FVR\)”](#) for more information on the Fixed Voltage Reference module.

See [Section 25.0 “5-Bit Digital-to-Analog Converter \(DAC1\) Module”](#) for more information on the DAC input signal.

Any time the comparator is disabled (CxON = 0), all comparator inputs are disabled.

18.7 Comparator Negative Input Selection

The CxNCH<2:0> bits of the CMxCON1 register direct an analog input pin and internal reference voltage or analog ground to the inverting input of the comparator:

- CxIN- pin
- FVR (Fixed Voltage Reference)
- Analog Ground

Some inverting input selections share a pin with the operational amplifier output function. Enabling both functions at the same time will direct the operational amplifier output to the comparator inverting input.

Note: To use CxINy+ and CxINy- pins as analog input, the appropriate bits must be set in the ANSEL register and the corresponding TRIS bits must also be set to disable the output drivers.

PIC16(L)F18856/76

18.8 Comparator Response Time

The comparator output is indeterminate for a period of time after the change of an input source or the selection of a new reference voltage. This period is referred to as the response time. The response time of the comparator differs from the settling time of the voltage reference. Therefore, both of these times must be considered when determining the total response time to a comparator input change. See the Comparator and Voltage Reference Specifications in [Table 37-14](#) for more details.

18.9 Analog Input Connection Considerations

A simplified circuit for an analog input is shown in [Figure 18-3](#). Since the analog input pins share their connection with a digital input, they have reverse biased ESD protection diodes to V_{DD} and V_{SS} . The analog input, therefore, must be between V_{SS} and V_{DD} . If the input voltage deviates from this range by more than 0.6V in either direction, one of the diodes is forward biased and a latch-up may occur.

A maximum source impedance of 10 k Ω is recommended for the analog sources. Also, any external component connected to an analog input pin, such as a capacitor or a Zener diode, should have very little leakage current to minimize inaccuracies introduced.

Note 1: When reading a PORT register, all pins configured as analog inputs will read as a '0'. Pins configured as digital inputs will convert as an analog input, according to the input specification.

2: Analog levels on any pin defined as a digital input, may cause the input buffer to consume more current than is specified.

FIGURE 18-3: ANALOG INPUT MODEL

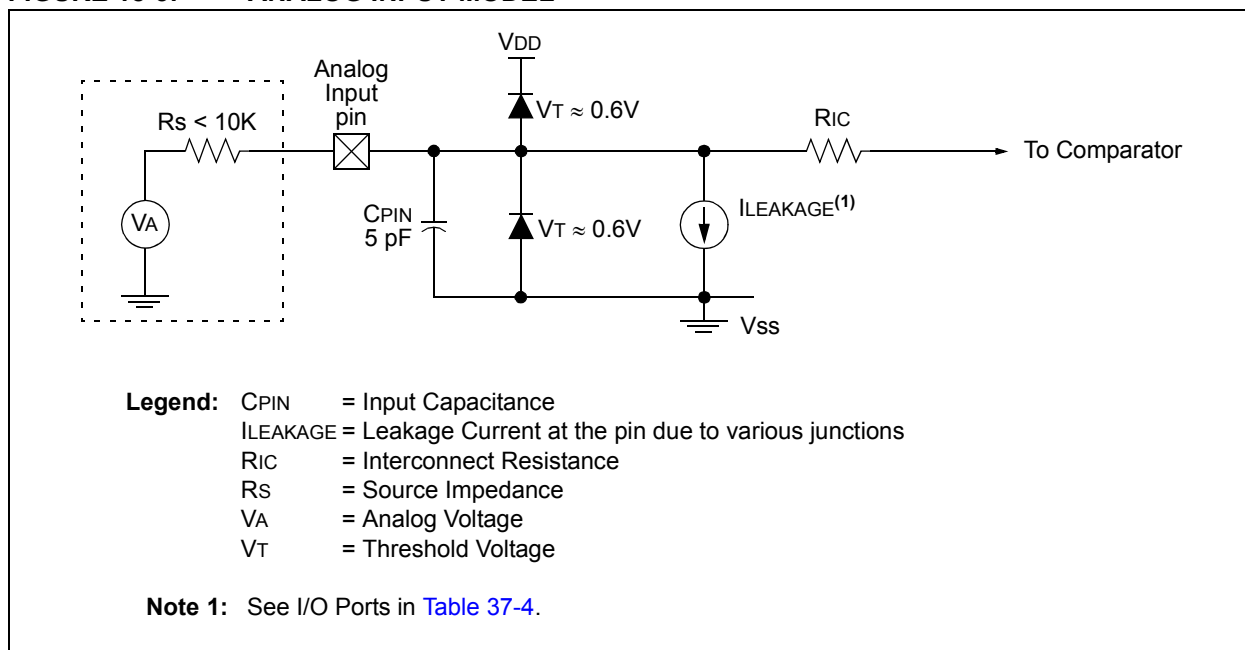

18.10 CWG1 Auto-shutdown Source

The output of the comparator module can be used as an auto-shutdown source for the CWG1 module. When the output of the comparator is active and the corresponding ASxE is enabled, the CWG operation will be suspended immediately (see [Section 20.10 “Auto-Shutdown”](#)).

18.11 Operation in Sleep Mode

The comparator module can operate during Sleep. The comparator clock source is based on the Timer1 clock source. If the Timer1 clock source is either the system clock (Fosc) or the instruction clock (Fosc/4), Timer1 will not operate during Sleep, and synchronized comparator outputs will not operate.

A comparator interrupt will wake the device from Sleep. The CxIE bits of the PIE2 register must be set to enable comparator interrupts.

PIC16(L)F18856/76

18.12 Register Definitions: Comparator Control

REGISTER 18-1: CMxCON0: COMPARATOR Cx CONTROL REGISTER 0

R/W-0/0	R-0/0	U-0	R/W-0/0	U-0	U-0	R/W-0/0	R/W-0/0
ON	OUT	—	POL	—	—	HYS	SYNC
bit 7						bit 0	

Legend:

R = Readable bit	W = Writable bit	U = Unimplemented bit, read as '0'
u = Bit is unchanged	x = Bit is unknown	-n/n = Value at POR and BOR/Value at all other Resets
'1' = Bit is set	'0' = Bit is cleared	

- bit 7 **ON:** Comparator Enable bit
 1 = Comparator is enabled
 0 = Comparator is disabled and consumes no active power
- bit 6 **OUT:** Comparator Output bit
 If CxPOL = 1 (inverted polarity):
 1 = CxVP < CxVN
 0 = CxVP > CxVN
 If CxPOL = 0 (non-inverted polarity):
 1 = CxVP > CxVN
 0 = CxVP < CxVN
- bit 5 **Unimplemented:** Read as '0'
- bit 4 **POL:** Comparator Output Polarity Select bit
 1 = Comparator output is inverted
 0 = Comparator output is not inverted
- bit 3-2 **Unimplemented:** Read as '0'
- bit 1 **HYS:** Comparator Hysteresis Enable bit
 1 = Comparator hysteresis enabled
 0 = Comparator hysteresis disabled
- bit 0 **SYNC:** Comparator Output Synchronous Mode bit
 1 = Comparator output to Timer1 and I/O pin is synchronous to changes on Timer1 clock source.
 Output updated on the falling edge of Timer1 clock source.
 0 = Comparator output to Timer1 and I/O pin is asynchronous

PIC16(L)F18856/76

REGISTER 18-2: CMxCON1: COMPARATOR Cx CONTROL REGISTER 1

U-0	U-0	U-0	U-0	U-0	U-0	R/W-0/0	R/W-0/0
—	—	—	—	—	—	INTP	INTN
bit 7						bit 0	

Legend:		
R = Readable bit	W = Writable bit	U = Unimplemented bit, read as '0'
u = Bit is unchanged	x = Bit is unknown	-n/n = Value at POR and BOR/Value at all other Resets
'1' = Bit is set	'0' = Bit is cleared	

bit 7-2 **Unimplemented:** Read as '0'

bit 1 **INTP:** Comparator Interrupt on Positive-Going Edge Enable bits
 1 = The CxIF interrupt flag will be set upon a positive-going edge of the CxOUT bit
 0 = No interrupt flag will be set on a positive-going edge of the CxOUT bit

bit 0 **INTN:** Comparator Interrupt on Negative-Going Edge Enable bits
 1 = The CxIF interrupt flag will be set upon a negative-going edge of the CxOUT bit
 0 = No interrupt flag will be set on a negative-going edge of the CxOUT bit

PIC16(L)F18856/76

REGISTER 18-3: CMxNSEL: COMPARATOR Cx NEGATIVE INPUT SELECT REGISTER

U-0	U-0	U-0	U-0	U-0	R/W-0/0	R/W-0/0	R/W-0/0
—	—	—	—	—	NCH<2:0>		
bit 7					bit 0		

Legend:

R = Readable bit	W = Writable bit	U = Unimplemented bit, read as '0'
u = Bit is unchanged	x = Bit is unknown	-n/n = Value at POR and BOR/Value at all other Resets
'1' = Bit is set	'0' = Bit is cleared	

bit 7-2 **Unimplemented:** Read as '0'

bit 2-0 **NCH<2:0>:** Comparator Negative Input Channel Select bits

111 = CxVN connects to AVss
110 = CxVN connects to FVR Buffer 2
101 = CxVN unconnected
100 = CxVN unconnected
011 = CxVN connects to CxIN3- pin
010 = CxVN connects to CxIN2- pin
001 = CxVN connects to CxIN1- pin
000 = CxVN connects to CxIN0- pin

REGISTER 18-4: CMxPSEL: COMPARATOR Cx POSITIVE INPUT SELECT REGISTER

U-0	U-0	U-0	U-0	U-0	R/W-0/0	R/W-0/0	R/W-0/0
—	—	—	—	—	PCH<2:0>		
bit 7					bit 0		

Legend:

R = Readable bit	W = Writable bit	U = Unimplemented bit, read as '0'
u = Bit is unchanged	x = Bit is unknown	-n/n = Value at POR and BOR/Value at all other Resets
'1' = Bit is set	'0' = Bit is cleared	

bit 7-2 **Unimplemented:** Read as '0'

bit 5-3 **PCH<2:0>:** Comparator Positive Input Channel Select bits

111 = CxVP connects to AVss
110 = CxVP connects to FVR Buffer 2
101 = CxVP connects to DAC output
100 = CxVP unconnected
011 = CxVP unconnected
010 = CxVP unconnected
001 = CxVP connects to CxIN1+ pin
000 = CxVP connects to CxIN0+ pin

PIC16(L)F18856/76

REGISTER 18-5: CMOUT: COMPARATOR OUTPUT REGISTER

U-0	U-0	U-0	U-0	U-0	U-0	R-0/0	R-0/0
—	—	—	—	—	—	MC2OUT	MC1OUT
bit 7						bit 0	

Legend:

R = Readable bit	W = Writable bit	U = Unimplemented bit, read as '0'
u = Bit is unchanged	x = Bit is unknown	-n/n = Value at POR and BOR/Value at all other Resets
'1' = Bit is set	'0' = Bit is cleared	

- bit 7-2 **Unimplemented:** Read as '0'
- bit 1 **MC2OUT:** Mirror Copy of C2OUT bit
- bit 0 **MC1OUT:** Mirror Copy of C1OUT bit

TABLE 18-3: SUMMARY OF REGISTERS ASSOCIATED WITH COMPARATOR MODULE

Name	Bit 7	Bit 6	Bit 5	Bit 4	Bit 3	Bit 2	Bit 1	Bit 0	Register on Page
ANSELA	ANSA7	ANSA6	ANSA5	ANSA4	ANSA3	ANSA2	ANSA1	ANSA0	205
ANSELB	ANSB7	ANSB6	ANSB5	ANSB4	ANSB3	ANSB2	ANSB1	ANSB0	213
CMxCON0	ON	OUT	—	POL	—	—	HYS	SYNC	279
CMxCON1	—	—	—	—	—	—	INTP	INTN	280
CMOUT	—	—	—	—	—	—	MC2OUT	MC1OUT	282
CWG1AS1	—	AS6E	AS5E	AS4E	AS3E	AS2E	AS1E	AS0E	310
CWG2AS1	—	AS6E	AS5E	AS4E	AS3E	AS2E	AS1E	AS0E	310
CWG3AS1	—	AS6E	AS5E	AS4E	AS3E	AS2E	AS1E	AS0E	310
FVRCON	FVREN	FVRRDY	TSEN	TSRNG	CDAFVR<1:0>		ADFVR<1:0>		269
DAC1CON0	DAC1EN	—	DAC1OE1	DAC1OE2	DAC1PSS<1:0>		—	DAC1NSS	389
DAC1CON1	—	—	—	DAC1R<4:0>					389
INTCON	GIE	PEIE	—	—	—	—	—	—	134
PIE2	—	ZCDIE	—	—	—	—	C2IE	C1IE	137
PIR2	—	ZCDIF	—	—	—	—	C2IF	C1IF	146
RxyPPS	—	—	RxyPPS<5:0>						250
CLCINxPPS	—	—	—	CLCIN0PPS<4:0>					249
MDSRCPPS	—	—	—	MDSRCPPS<4:0>					249
T1GPPS	—	—	—	T1GPPS<4:0>					249
TRISA	TRISA7	TRISA6	TRISA5	TRISA4	TRISA3	TRISA2	TRISA1	TRISA0	204
TRISB	TRISB7	TRISB6	TRISB5	TRISB4	TRISB3	TRISB2	TRISB1	TRISB0	212

Legend: — = unimplemented location, read as '0'. Shaded cells are unused by the Comparator module.

PIC16(L)F18856/76

19.0 PULSE-WIDTH MODULATION (PWM)

The PWMx modules generate Pulse-Width Modulated (PWM) signals of varying frequency and duty cycle.

In addition to the CCP modules, the PIC16(L)F18855/75 devices contain two PWM modules (PWM6 and PWM7). These modules are essentially the same as the CCP modules without the Capture or Compare functionality.

Note: The PWM6 and PWM7 modules are two instances of the same PWM module design. Throughout this section, the lower case 'x' in register and bit names is a generic reference to the PWM module number (which should be substituted with 6 or 7 during code development). For example, the control register is generically described in this chapter as PWMxCON, but the actual device registers are PWM6CON and PWM7CON. Similarly, the PWMxEN bit represents the PWM6EN and PWM7EN bits.

Pulse-Width Modulation (PWM) is a scheme that provides power to a load by switching quickly between fully on and fully off states. The PWM signal resembles a square wave where the high portion of the signal is considered the 'on' state (pulse width), and the low portion of the signal is considered the 'off' state. The term duty cycle describes the proportion of the 'on' time to the 'off' time and is expressed in percentages, where 0% is fully off and 100% is fully on. A lower duty cycle corresponds to less power applied and a higher duty cycle corresponds to more power applied. The PWM period is defined as the duration of one complete cycle or the total amount of on and off time combined.

PWM resolution defines the maximum number of steps that can be present in a single PWM period. A higher resolution allows for more precise control of the pulse width time and, in turn, the power that is applied to the load.

Figure 19-1 shows a typical waveform of the PWM signal.

FIGURE 19-1: PWM OUTPUT

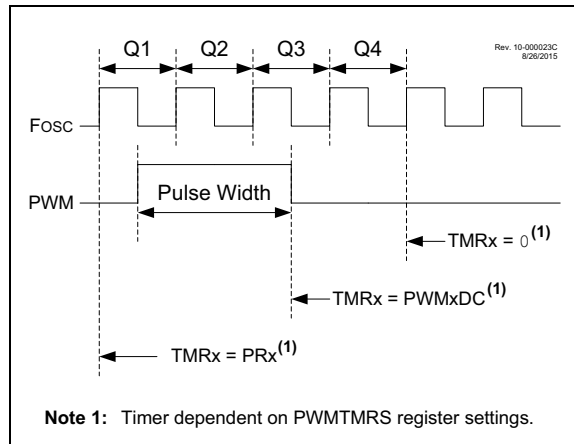

PIC16(L)F18856/76

19.1 Standard PWM Mode

The standard PWM mode generates a Pulse-Width Modulation (PWM) signal on the PWMx pin with up to ten bits of resolution. The period, duty cycle, and resolution are controlled by the following registers:

- TMR2 register
- PR2 register
- PWMxCON registers
- PWMxDCH registers
- PWMxDCL registers

Figure 19-2 shows a simplified block diagram of PWM operation.

If PWMPOL = 0, the default state of the output is '0'. If PWMPOL = 1, the default state is '1'. If PWMEN = '0', the output will be the default state.

Note: The corresponding TRIS bit must be cleared to enable the PWM output on the PWMx pin

FIGURE 19-2: SIMPLIFIED PWM BLOCK DIAGRAM

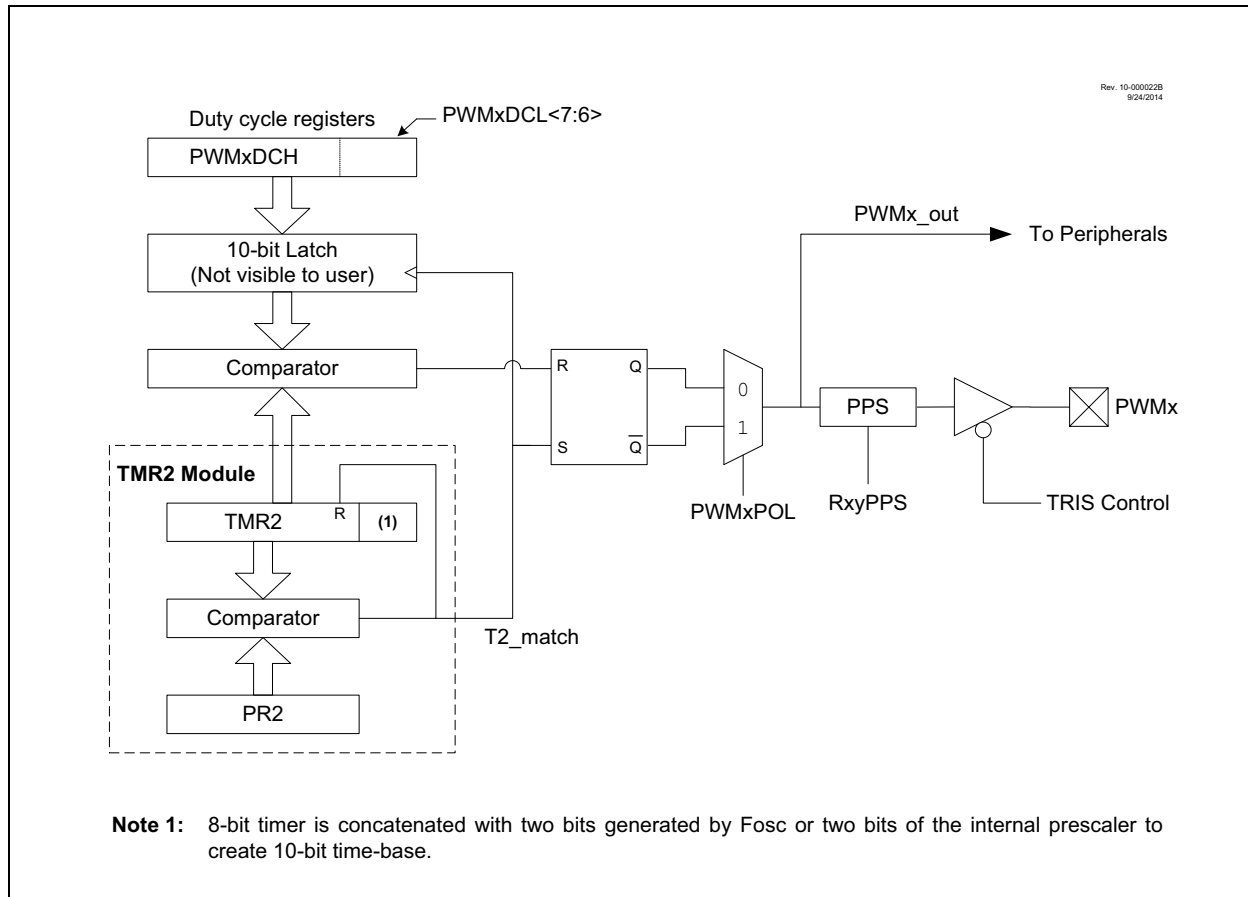

PIC16(L)F18856/76

19.1.1 PWM CLOCK SELECTION

The PIC16(L)F18855/75 allows each individual CCP and PWM module to select the timer source that controls the module. Each module has an independent selection.

As there are up to three 8-bit timers with auto-reload (Timer2/4/6), PWM mode on the CCP and PWM modules can use any of these timers.

The CCPTMRS0 and CCPTMRS1 register are used to select which timer is used.

19.1.2 USING THE TMR2/4/6 WITH THE PWM MODULE

This device has a newer version of the TMR2 module that has many new modes, which allow for greater customization and control of the PWM signals than on older parts. Refer to [Section 29.5, Operation Examples](#) for examples of PWM signal generation using the different modes of Timer2. PWM operation requires that the timer used as the PWM time base has the FOSC/4 clock source selected.

19.1.3 PWM PERIOD

Referring to [Figure 19-1](#), the PWM output has a period and a pulse width. The frequency of the PWM is the inverse of the period (1/period).

The PWM period is specified by writing to the PR2 register. The PWM period can be calculated using the following formula:

EQUATION 19-1: PWM PERIOD

$$PWM\ Period = [(PR2) + 1] \cdot 4 \cdot TOSC \cdot (TMR2\ Prescale\ Value)$$

Note 1: $Tosc = 1/Fosc$

When TMR2 is equal to PR2, the following three events occur on the next increment cycle:

- TMR2 is cleared
- The PWMx pin is set (Exception: If the PWM duty cycle = 0%, the pin will not be set.)
- The PWM pulse width is latched from PWMxDC.

Note: If the pulse width value is greater than the period the assigned PWM pin(s) will remain unchanged.

19.1.4 PWM DUTY CYCLE

The PWM duty cycle is specified by writing a 10-bit value to the PWMxDC register. The PWMxDCH contains the eight MSbs and the PWMxDCL<7:6> bits contain the two LSbs.

The PWMDC register is double-buffered and can be updated at any time. This double buffering is essential for glitch-free PWM operation. New values take effect when TMR2 = PR2. Note that PWMDC is left-justified.

The 8-bit timer TMR2 register is concatenated with either the 2-bit internal system clock (FOSC), or two bits of the prescaler, to create the 10-bit time base. The system clock is used if the Timer2 prescaler is set to 1:1.

[Equation 19-2](#) is used to calculate the PWM pulse width.

[Equation 19-3](#) is used to calculate the PWM duty cycle ratio.

EQUATION 19-2: PULSE WIDTH

$$Pulse\ Width = (PWMxDC) \cdot TOSC \cdot (TMR2\ Prescale\ Value)$$

EQUATION 19-3: DUTY CYCLE RATIO

$$Duty\ Cycle\ Ratio = \frac{(PWMxDC)}{4(PR2 + 1)}$$

19.1.5 PWM RESOLUTION

The resolution determines the number of available duty cycles for a given period. For example, a 10-bit resolution will result in 1024 discrete duty cycles, whereas an 8-bit resolution will result in 256 discrete duty cycles.

The maximum PWM resolution is ten bits when PR2 is 255. The resolution is a function of the PR2 register value as shown by [Equation 19-4](#).

EQUATION 19-4: PWM RESOLUTION

$$Resolution = \frac{\log[4(PR2 + 1)]}{\log(2)}\ bits$$

Note: If the pulse width value is greater than the period the assigned PWM pin(s) will remain unchanged.

19.1.6 OPERATION IN SLEEP MODE

In Sleep mode, the TMR2 register will not increment and the state of the module will not change. If the PWMx pin is driving a value, it will continue to drive that value. When the device wakes up, TMR2 will continue from its previous state.

PIC16(L)F18856/76

19.1.7 CHANGES IN SYSTEM CLOCK FREQUENCY

The PWM frequency is derived from the system clock frequency. Any changes in the system clock frequency will result in changes to the PWM frequency. See [Section 6.0 “Oscillator Module \(with Fail-Safe Clock Monitor\)”](#) for additional details.

19.1.8 EFFECTS OF RESET

Any Reset will force all ports to Input mode and the PWMx registers to their Reset states.

TABLE 19-1: EXAMPLE PWM FREQUENCIES AND RESOLUTIONS (Fosc = 20 MHz)

PWM Frequency	1.22 kHz	4.88 kHz	19.53 kHz	78.12 kHz	156.3 kHz	208.3 kHz
Timer Prescale	16	4	1	1	1	1
PR2 Value	0xFF	0xFF	0xFF	0x3F	0x1F	0x17
Maximum Resolution (bits)	10	10	10	8	7	6.6

TABLE 19-2: EXAMPLE PWM FREQUENCIES AND RESOLUTIONS (Fosc = 8 MHz)

PWM Frequency	1.22 kHz	4.90 kHz	19.61 kHz	76.92 kHz	153.85 kHz	200.0 kHz
Timer Prescale	16	4	1	1	1	1
PR2 Value	0xFF	0xFF	0xFF	0x3F	0x1F	0x17
Maximum Resolution (bits)	10	10	10	8	7	6.6

19.1.9 SETUP FOR PWM OPERATION

The following steps should be taken when configuring the module for using the PWMx outputs:

1. Disable the PWMx pin output driver(s) by setting the associated TRIS bit(s).
2. Configure the PWM output polarity by configuring the PWMxPOL bit of the PWMxCON register.
3. Load the PR2 register with the PWM period value, as determined by [Equation 19-1](#).
4. Load the PWMxDCH register and bits <7:6> of the PWMxDCL register with the PWM duty cycle value, as determined by [Equation 19-2](#).
5. Configure and start Timer2:
 - Clear the TMR2IF interrupt flag bit of the PIR1 register.
 - Select the Timer2 prescale value by configuring the T2CKPS<1:0> bits of the T2CON register.
 - Enable Timer2 by setting the TMR2ON bit of the T2CON register.
6. Wait until the TMR2IF is set.
7. When the TMR2IF flag bit is set:
 - Clear the associated TRIS bit(s) to enable the output driver.

- Route the signal to the desired pin by configuring the RxyPPS register.
- Enable the PWMx module by setting the PWMxEN bit of the PWMxCON register.

In order to send a complete duty cycle and period on the first PWM output, the above steps must be followed in the order given. If it is not critical to start with a complete PWM signal, then the PWM module can be enabled during Step 2 by setting the PWMxEN bit of the PWMxCON register.

PIC16(L)F18856/76

19.2 Register Definitions: PWM Control

REGISTER 19-1: PWMxCON: PWM CONTROL REGISTER

R/W-0/0	U-0	R-0	R/W-0/0	U-0	U-0	U-0	U-0
PWMxEN	—	PWMxOUT	PWMxPOL	—	—	—	—
bit 7							bit 0

Legend:

R = Readable bit

W = Writable bit

U = Unimplemented bit, read as '0'

u = Bit is unchanged

x = Bit is unknown

-n/n = Value at POR and BOR/Value at all other Resets

'1' = Bit is set

'0' = Bit is cleared

bit 7 **PWMxEN:** PWM Module Enable bit

1 = PWM module is enabled

0 = PWM module is disabled

bit 6 **Unimplemented:** Read as '0'

bit 5 **PWMxOUT:** PWM Module Output Level when Bit is Read

bit 4 **PWMxPOL:** PWMx Output Polarity Select bit

1 = PWM output is active-low

0 = PWM output is active-high

bit 3-0 **Unimplemented:** Read as '0'

PIC16(L)F18856/76

REGISTER 19-2: PWMxDCH: PWM DUTY CYCLE HIGH BITS

R/W-x/u	R/W-x/u	R/W-x/u	R/W-x/u	R/W-x/u	R/W-x/u	R/W-x/u	R/W-x/u
PWMxDC<9:2>							
bit 7							bit 0

Legend:

R = Readable bit	W = Writable bit	U = Unimplemented bit, read as '0'
u = Bit is unchanged	x = Bit is unknown	-n/n = Value at POR and BOR/Value at all other Resets
'1' = Bit is set	'0' = Bit is cleared	

bit 7-0 **PWMxDC<9:2>**: PWM Duty Cycle Most Significant bits
 These bits are the MSBs of the PWM duty cycle. The two LSBs are found in PWMxDCL Register.

REGISTER 19-3: PWMxDCL: PWM DUTY CYCLE LOW BITS

R/W-x/u	R/W-x/u	U-0	U-0	U-0	U-0	U-0	U-0
PWMxDC<1:0>		—	—	—	—	—	—
bit 7							bit 0

Legend:

R = Readable bit	W = Writable bit	U = Unimplemented bit, read as '0'
u = Bit is unchanged	x = Bit is unknown	-n/n = Value at POR and BOR/Value at all other Resets
'1' = Bit is set	'0' = Bit is cleared	

bit 7-6 **PWMxDC<1:0>**: PWM Duty Cycle Least Significant bits
 These bits are the LSBs of the PWM duty cycle. The MSBs are found in PWMxDCH Register.

bit 5-0 **Unimplemented**: Read as '0'

PIC16(L)F18856/76

TABLE 19-3: SUMMARY OF REGISTERS ASSOCIATED WITH PWMx

Name	Bit 7	Bit 6	Bit 5	Bit 4	Bit 3	Bit 2	Bit 1	Bit 0	Register on Page
PWM6CON	PWM6EN	—	PWM6OUT	PWM6POL	—	—	—	—	287
PWM6DCH	PWM6DC<9:2>								288
PWM6DCL	PWM6DC<1:0>		—	—	—	—	—	—	288
PWM7CON	PWM7EN	—	PWM7OUT	PWM7POL	—	—	—	—	287
PWM7DCH	PWM7DC<9:2>								288
PWM7DCL	PWM7DC<1:0>		—	—	—	—	—	—	288
T2CON	ON	CKPS<2:0>			OUTPS<3:0>				441
T4CON	ON	CKPS<2:0>			OUTPS<3:0>				441
T6CON	ON	CKPS<2:0>			OUTPS<3:0>				441
T2TMR	Holding Register for the 8-bit TMR2 Register								
T4TMR	Holding Register for the 8-bit TMR4 Register								
T6TMR	Holding Register for the 8-bit TMR6 Register								
T2PR	TMR2 Period Register								
T4PR	TMR4 Period Register								
T6PR	TMR6 Period Register								
RxyPPS	—	—	RxyPPS<5:0>						250
CWG1ISM	—	—	—	—	IS<3:0>				312
CWG2ISM	—	—	—	—	IS<3:0>				312
CWG3ISM	—	—	—	—	IS<3:0>				312
CLCxSELY	—	—	LCxDyS<5:0>						329
MDSRC	—	—	—	MDMS<4:0>					399
MDCARH	—	—	—	—	MDCHS<3:0>				400
MDCARL	—	—	—	—	MDCLS<3:0>				401
TRISA	TRISA7	TRISA6	TRISA5	TRISA4	TRISA3	TRISA2	TRISA1	TRISA0	204
TRISC	TRISC7	TRISC6	TRISC5	TRISC4	TRISC3	TRISC2	TRISC1	TRISC0	220

Legend: — = Unimplemented locations, read as '0'. Shaded cells are not used by the PWMx module.

PIC16(L)F18856/76

20.0 COMPLEMENTARY WAVEFORM GENERATOR (CWG) MODULE

The Complementary Waveform Generator (CWG) produces half-bridge, full-bridge, and steering of PWM waveforms. It is backwards compatible with previous ECCP functions.

The CWG has the following features:

- Six operating modes:
 - Synchronous Steering mode
 - Asynchronous Steering mode
 - Full-Bridge mode, Forward
 - Full-Bridge mode, Reverse
 - Half-Bridge mode
 - Push-Pull mode
- Output polarity control
- Output steering
 - Synchronized to rising event
 - Immediate effect
- Independent 6-bit rising and falling event dead-band timers
 - Clocked dead band
 - Independent rising and falling dead-band enables
- Auto-shutdown control with:
 - Selectable shutdown sources
 - Auto-restart enable
 - Auto-shutdown pin override control

The CWG modules available are shown in [Table 20-1](#).

TABLE 20-1: AVAILABLE CWG MODULES

Device	CWG1	CWG2	CWG2
PIC16(L)F18856/76	•	•	•

20.1 Fundamental Operation

The CWG module can operate in six different modes, as specified by MODE of the CWGxCON0 register:

- Half-Bridge mode ([Figure 20-9](#))
- Push-Pull mode ([Figure 20-2](#))
 - Full-Bridge mode, Forward ([Figure 20-3](#))
 - Full-Bridge mode, Reverse ([Figure 20-3](#))
- Steering mode ([Figure 20-10](#))
- Synchronous Steering mode ([Figure 20-11](#))

It may be necessary to guard against the possibility of circuit faults or a feedback event arriving too late or not at all. In this case, the active drive must be terminated before the Fault condition causes damage. Thus, all output modes support auto-shutdown, which is covered in [20.10 “Auto-Shutdown”](#).

20.1.1 HALF-BRIDGE MODE

In Half-Bridge mode, two output signals are generated as true and inverted versions of the input as illustrated in [Figure 20-9](#). A non-overlap (dead-band) time is inserted between the two outputs to prevent shoot through current in various power supply applications. Dead-band control is described in [Section 20.5 “Dead-Band Control”](#).

The unused outputs CWGxC and CWGxD drive similar signals, with polarity independently controlled by the POLC and POLD bits of the CWGxCON1 register, respectively.

FIGURE 20-1: SIMPLIFIED CWG BLOCK DIAGRAM (HALF-BRIDGE MODE)

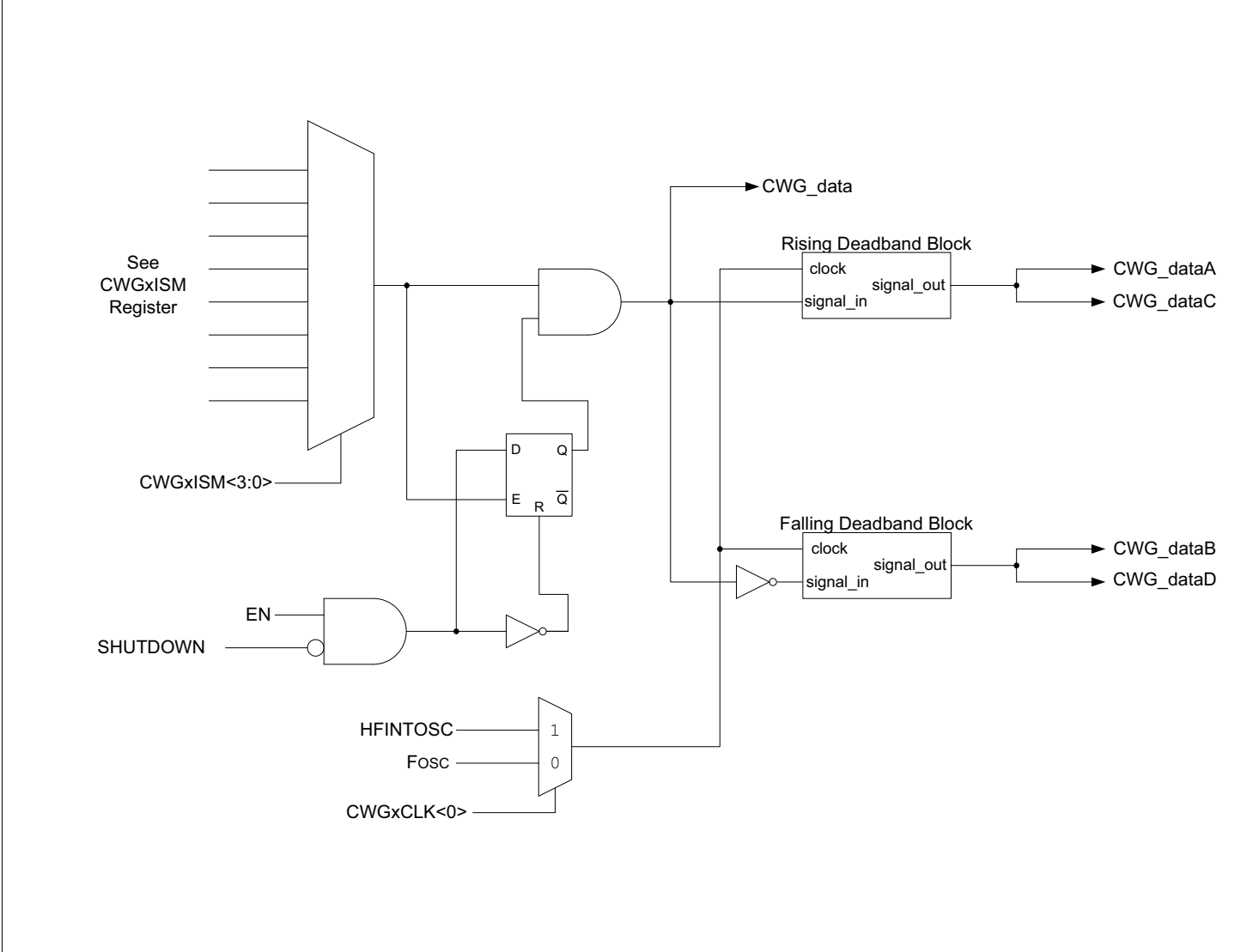

PIC16(L)F18856/76

20.1.2 PUSH-PULL MODE

In Push-Pull mode, two output signals are generated, alternating copies of the input as illustrated in [Figure 20-2](#). This alternation creates the push-pull effect required for driving some transformer-based power supply designs.

The push-pull sequencer is reset whenever $EN = 0$ or if an auto-shutdown event occurs. The sequencer is clocked by the first input pulse, and the first output appears on CWGxA.

The unused outputs CWGxC and CWGxD drive copies of CWGxA and CWGxB, respectively, but with polarity controlled by the POLC and POLD bits of the CWGxCON1 register, respectively.

20.1.3 FULL-BRIDGE MODES

In Forward and Reverse Full-Bridge modes, three outputs drive static values while the fourth is modulated by the input data signal. In Forward Full-Bridge mode, CWGxA is driven to its active state, CWGxB and CWGxC are driven to their inactive state, and CWGxD is modulated by the input signal. In Reverse Full-Bridge mode, CWGxC is driven to its active state, CWGxA and CWGxD are driven to their inactive states, and CWGxB is modulated by the input signal. In Full-Bridge mode, the dead-band period is used when there is a switch from forward to reverse or vice-versa. This dead-band control is described in [Section 20.5 “Dead-Band Control”](#), with additional details in [Section 20.6 “Rising Edge and Reverse Dead Band”](#) and [Section 20.7 “Falling Edge and Forward Dead Band”](#).

The mode selection may be toggled between forward and reverse toggling the MODE<0> bit of the CWGxCON0 while keeping MODE<2:1> static, without disabling the CWG module.

FIGURE 20-2: SIMPLIFIED CWG BLOCK DIAGRAM (PUSH-PULL MODE)

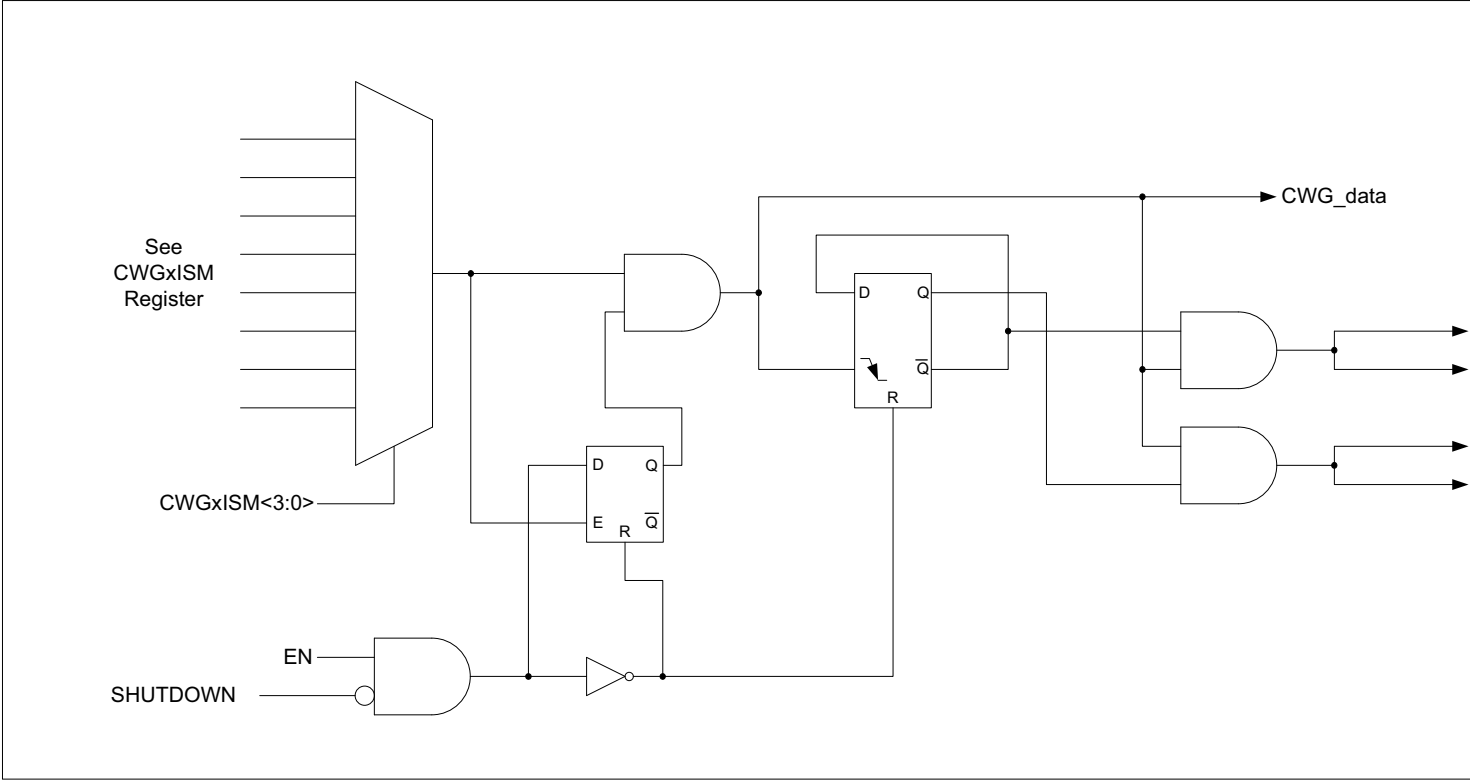
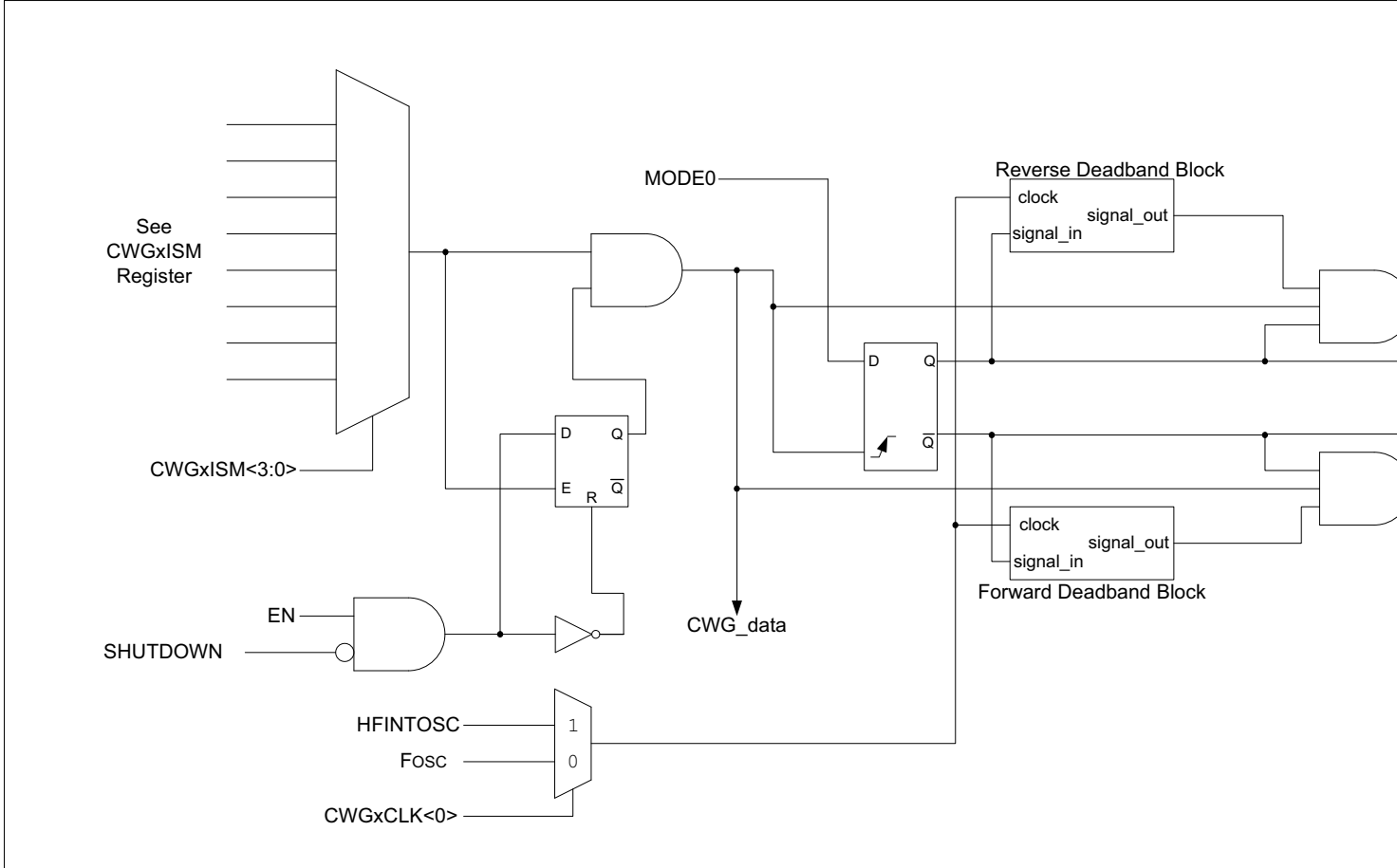

FIGURE 20-3: SIMPLIFIED CWG BLOCK DIAGRAM (FORWARD AND REVERSE FULL-BRIDGE MODES)



PIC16(L)F18856/76

20.1.4 STEERING MODES

In Steering modes, the data input can be steered to any or all of the four CWG output pins. In Synchronous Steering mode, changes to steering selection registers take effect on the next rising input.

In Non-Synchronous mode, steering takes effect on the next instruction cycle. Additional details are provided in [Section 20.9 “CWG Steering Mode”](#).

FIGURE 20-4: SIMPLIFIED CWG BLOCK DIAGRAM (OUTPUT STEERING MODES)

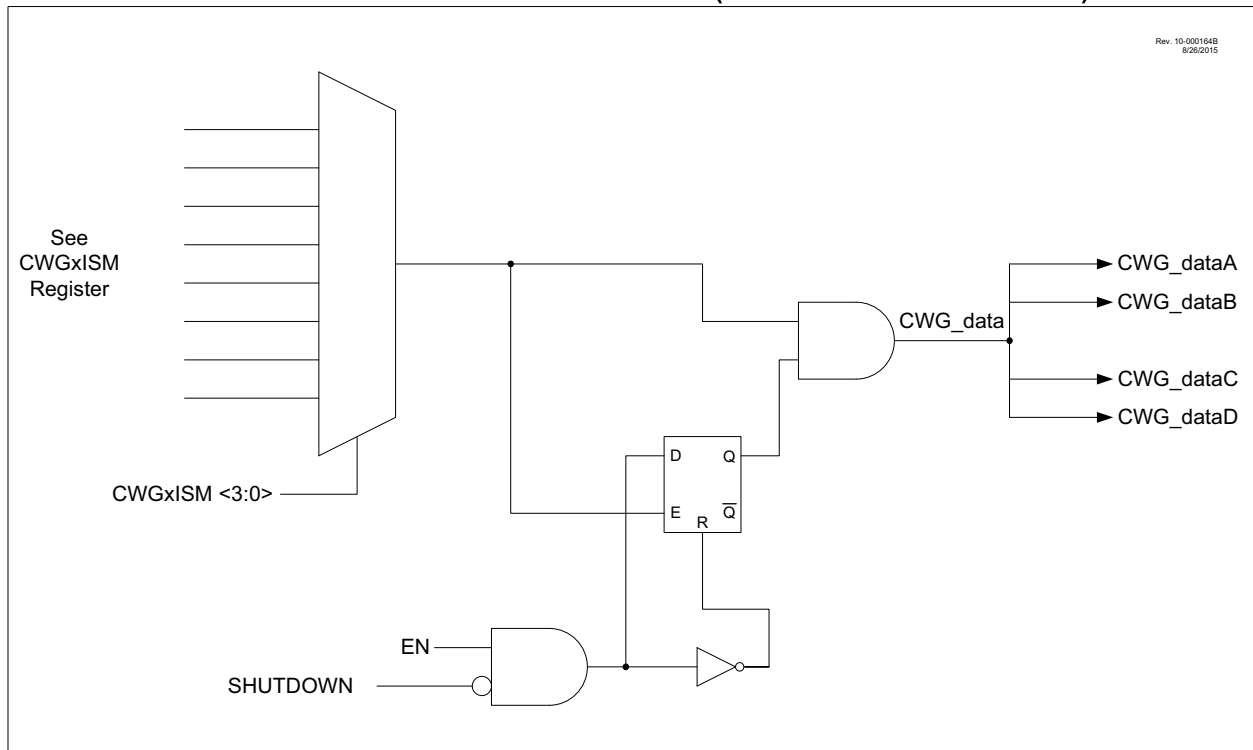

20.2 Clock Source

The CWG module allows the following clock sources to be selected:

- Fosc (system clock)
- HFINTOSC (16 MHz only)

The clock sources are selected using the CS bit of the CWGxCLKCON register.

PIC16(L)F18856/76

20.3 Selectable Input Sources

The CWG generates the output waveforms from the input sources in [Table 20-2](#).

TABLE 20-2: SELECTABLE INPUT SOURCES

Source Peripheral	Signal Name
CWG input PPS pin	CWGxIN PPS
CCP1	CCP1_out
CCP2	CCP2_out
CCP3	CCP3_out
CCP4	CCP4_out
CCP5	CCP5_out
PWM6	PWM6_out
PWM7	PWM7_out
NCO	NCO1_out
Comparator C1	C1OUT_sync
Comparator C2	C2OUT_sync
DSM	DSM_out
CLC1	LC1_out
CLC2	LC2_out
CLC3	LC3_out
CLC4	LC4_out

The input sources are selected using the CWGxISM register.

20.4 Output Control

20.4.1 OUTPUT ENABLES

Each CWG output pin has individual output enable control. Output enables are selected with the Gx1OEx <3:0> bits. When an output enable control is cleared, the module asserts no control over the pin. When an output enable is set, the override value or active PWM waveform is applied to the pin per the port priority selection. The output pin enables are dependent on the module enable bit, EN of the CWGxCON0 register. When EN is cleared, CWG output enables and CWG drive levels have no effect.

20.4.2 POLARITY CONTROL

The polarity of each CWG output can be selected independently. When the output polarity bit is set, the corresponding output is active-high. Clearing the output polarity bit configures the corresponding output as active-low. However, polarity does not affect the override levels. Output polarity is selected with the POLx bits of the CWGxCON1. Auto-shutdown and steering options are unaffected by polarity.

PIC16(L)F18856/76

FIGURE 20-5: CWG OUTPUT BLOCK DIAGRAM

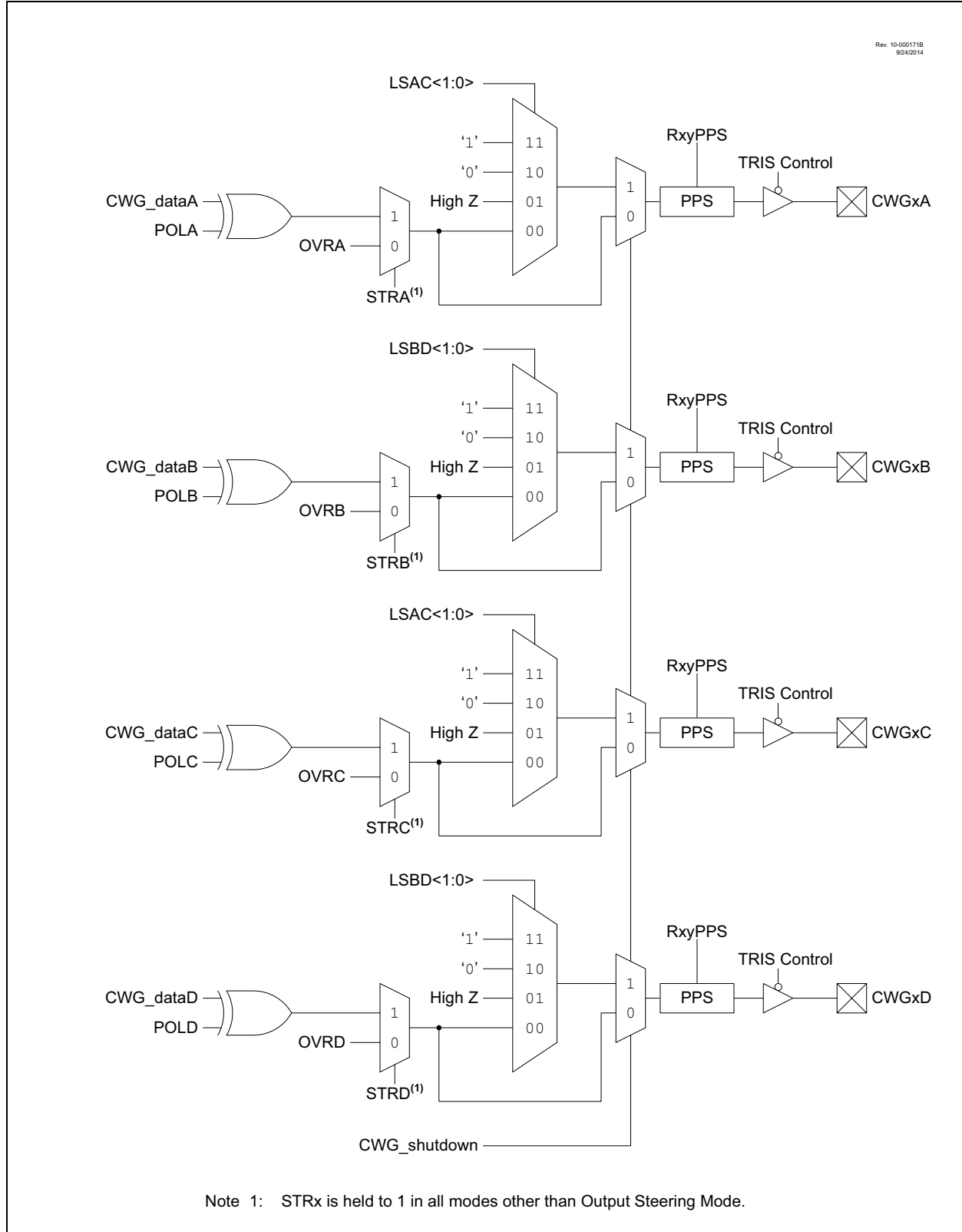

20.5 Dead-Band Control

The dead-band control provides non-overlapping PWM signals to prevent shoot-through current in PWM switches. Dead-band operation is employed for Half-Bridge and Full-Bridge modes. The CWG contains two 6-bit dead-band counters. One is used for the rising edge of the input source control in Half-Bridge mode or for reverse dead-band Full-Bridge mode. The other is used for the falling edge of the input source control in Half-Bridge mode or for forward dead band in Full-Bridge mode.

Dead band is timed by counting CWG clock periods from zero up to the value in the rising or falling dead-band counter registers. See CWGxDBR and CWGxDBF registers, respectively.

20.5.1 DEAD-BAND FUNCTIONALITY IN HALF-BRIDGE MODE

In Half-Bridge mode, the dead-band counters dictate the delay between the falling edge of the normal output and the rising edge of the inverted output. This can be seen in [Figure 20-9](#).

20.5.2 DEAD-BAND FUNCTIONALITY IN FULL-BRIDGE MODE

In Full-Bridge mode, the dead-band counters are used when undergoing a direction change. The MODE<0> bit of the CWGxCON0 register can be set or cleared while the CWG is running, allowing for changes from Forward to Reverse mode. The CWGxA and CWGxC signals will change immediately upon the first rising input edge following a direction change, but the modulated signals (CWGxB or CWGxD, depending on the direction of the change) will experience a delay dictated by the dead-band counters. This is demonstrated in [Figure 20-3](#).

20.6 Rising Edge and Reverse Dead Band

CWGxDBR controls the rising edge dead-band time at the leading edge of CWGxA (Half-Bridge mode) or the leading edge of CWGxB (Full-Bridge mode). The CWGxDBR value is double-buffered. When EN = 0, the CWGxDBR register is loaded immediately when CWGxDBR is written. When EN = 1, then software must set the LD bit of the CWGxCON0 register, and the buffer will be loaded at the next falling edge of the CWG input signal. If the input source signal is not present for enough time for the count to be completed, no output will be seen on the respective output.

20.7 Falling Edge and Forward Dead Band

CWGxDBF controls the dead-band time at the leading edge of CWGxB (Half-Bridge mode) or the leading edge of CWGxD (Full-Bridge mode). The CWGxDBF value is double-buffered. When EN = 0, the CWGxDBF register is loaded immediately when CWGxDBF is written. When EN = 1 then software must set the LD bit of the CWGxCON0 register, and the buffer will be loaded at the next falling edge of the CWG input signal. If the input source signal is not present for enough time for the count to be completed, no output will be seen on the respective output.

Refer to [Figure 20.6](#) and [Figure 20-7](#) for examples.

FIGURE 20-6: DEAD-BAND OPERATION CWGXDBR = 0X01, CWGXDBF = 0X02

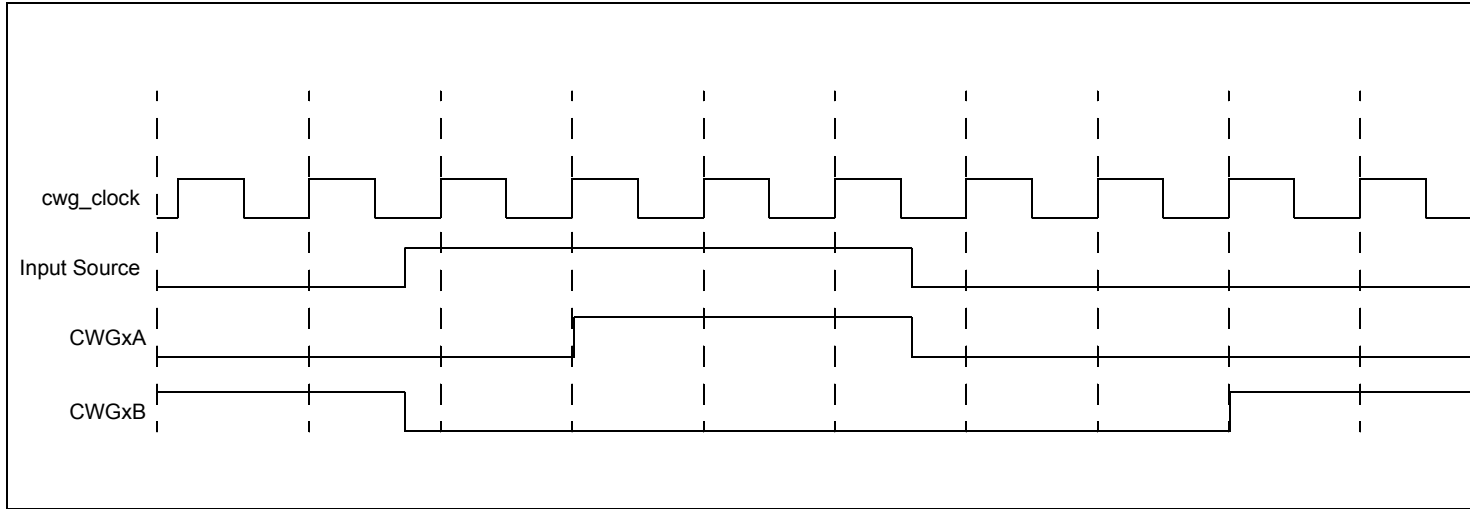
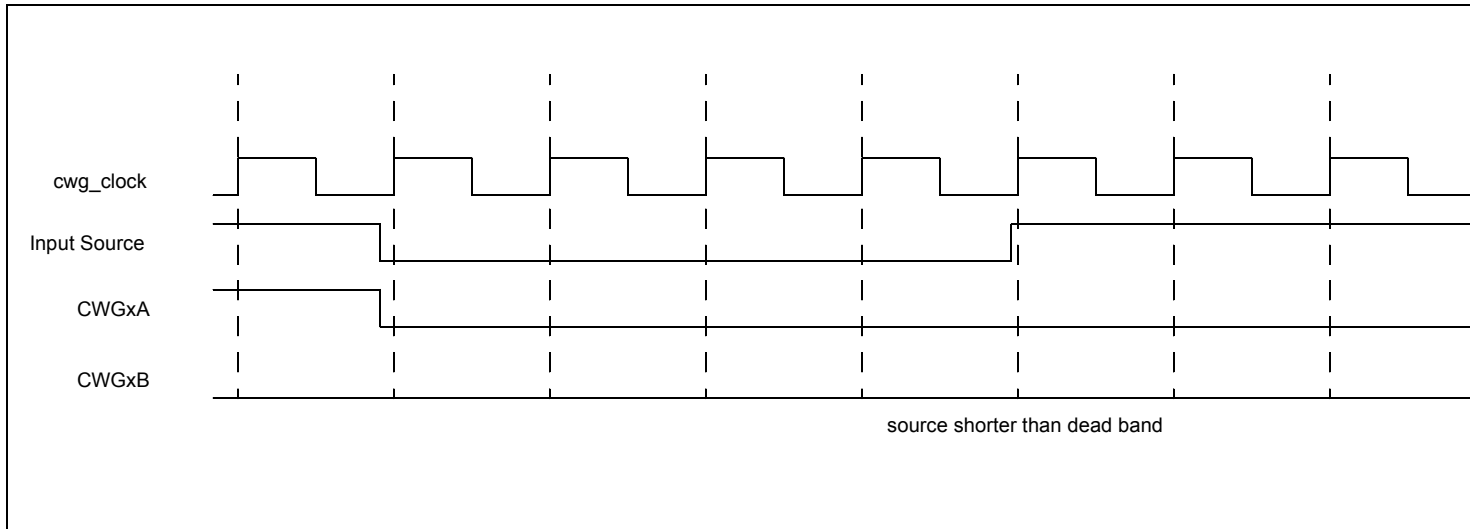

FIGURE 20-7: DEAD-BAND OPERATION, CWGXDBR = 0X03, CWGXDBF = 0X04, SOURCE SHORTER THAN DEAD BAND



PIC16(L)F18856/76

20.8 Dead-Band Uncertainty

When the rising and falling edges of the input source are asynchronous to the CWG clock, it creates uncertainty in the dead-band time delay. The maximum uncertainty is equal to one CWG clock period. Refer to [Equation 20-1](#) for more details.

EQUATION 20-1: DEAD-BAND UNCERTAINTY

$$T_{DEADBAND_UNCERTAINTY} = \frac{1}{F_{cwg_clock}}$$

Example:

$$F_{CWG_CLOCK} = 16\text{ MHz}$$

Therefore:

$$\begin{aligned} T_{DEADBAND_UNCERTAINTY} &= \frac{1}{F_{cwg_clock}} \\ &= \frac{1}{16\text{ MHz}} \\ &= 62.5\text{ ns} \end{aligned}$$

FIGURE 20-8: EXAMPLE OF PWM DIRECTION CHANGE

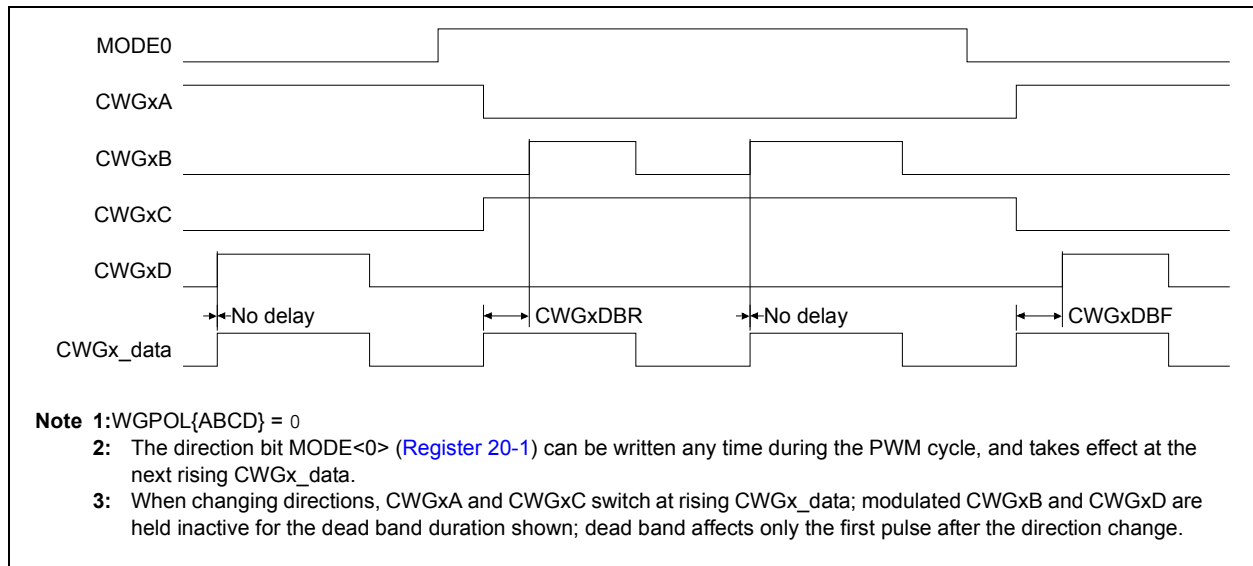
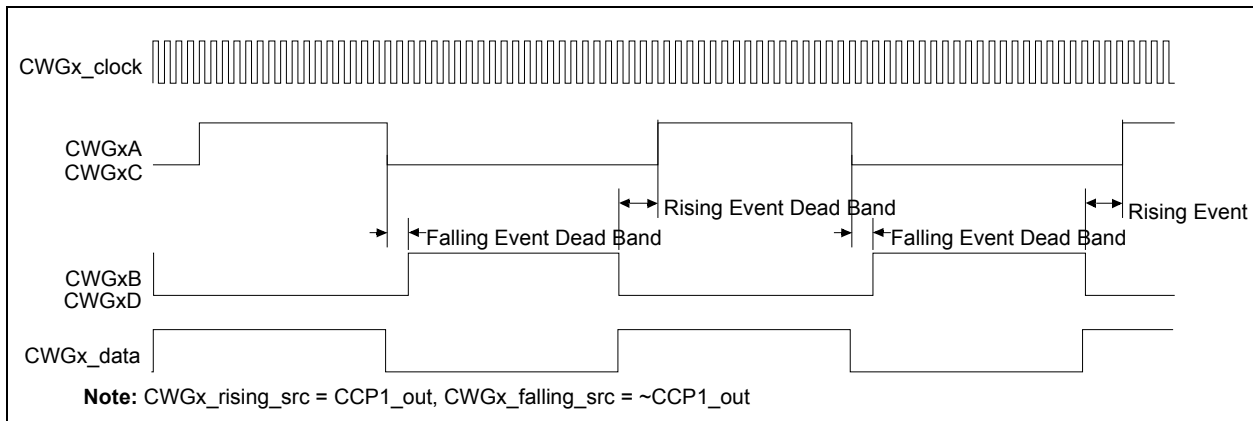

FIGURE 20-9: CWG HALF-BRIDGE MODE OPERATION



PIC16(L)F18856/76

20.9 CWG Steering Mode

In Steering mode ($MODE = 00x$), the CWG allows any combination of the $CWGx$ pins to be the modulated signal. The same signal can be simultaneously available on multiple pins, or a fixed-value output can be presented.

When the respective $STRx$ bit of $CWGxOCON0$ is '0', the corresponding pin is held at the level defined. When the respective $STRx$ bit of $CWGxOCON0$ is '1', the pin is driven by the input data signal. The user can assign the input data signal to one, two, three, or all four output pins.

The $POLx$ bits of the $CWGxCON1$ register control the signal polarity only when $STRx = 1$.

The CWG auto-shutdown operation also applies in Steering modes as described in [Section 20.10 "Auto-Shutdown"](#). An auto-shutdown event will only affect pins that have $STRx = 1$.

20.9.1 STEERING SYNCHRONIZATION

Changing the $MODE$ bits allows for two modes of steering, synchronous and asynchronous.

When $MODE = 000$, the steering event is asynchronous and will happen at the end of the instruction that writes to $STRx$ (that is, immediately). In this case, the output signal at the output pin may be an incomplete waveform. This can be useful for immediately removing a signal from the pin.

When $MODE = 001$, the steering update is synchronous and occurs at the beginning of the next rising edge of the input data signal. In this case, steering the output on/off will always produce a complete waveform.

[Figure 20-10](#) and [Figure 20-11](#) illustrate the timing of asynchronous and synchronous steering, respectively.

FIGURE 20-10: EXAMPLE OF STEERING EVENT AT END OF INSTRUCTION ($MODE<2:0> = 000$)

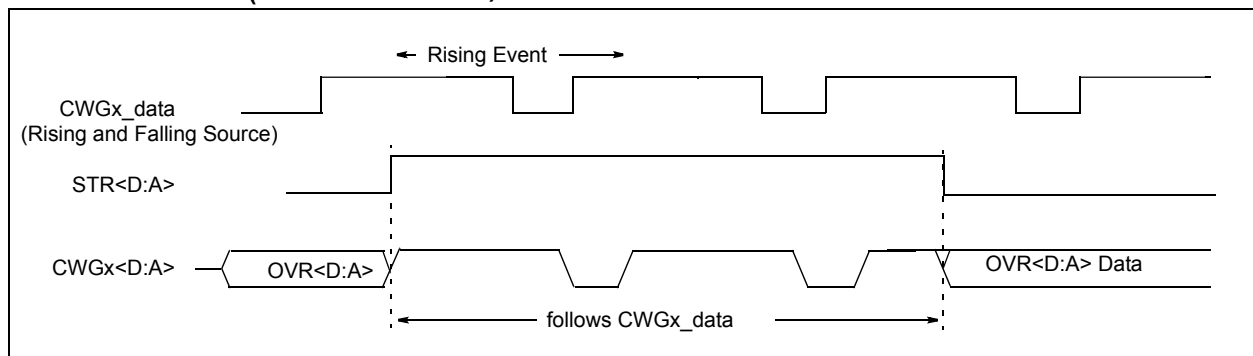
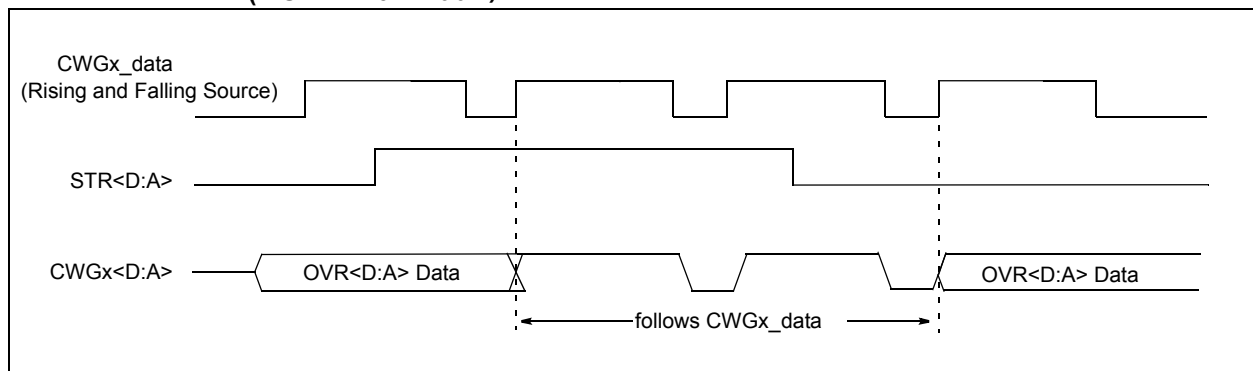

FIGURE 20-11: EXAMPLE OF STEERING EVENT AT BEGINNING OF INSTRUCTION ($MODE<2:0> = 001$)



PIC16(L)F18856/76

20.10 Auto-Shutdown

Auto-shutdown is a method to immediately override the CWG output levels with specific overrides that allow for safe shutdown of the circuit. The shutdown state can be either cleared automatically or held until cleared by software. The auto-shutdown circuit is illustrated in [Figure 20-12](#).

20.10.1 SHUTDOWN

The shutdown state can be entered by either of the following two methods:

- Software generated
- External Input

20.10.1.1 Software Generated Shutdown

Setting the SHUTDOWN bit of the CWGxAS0 register will force the CWG into the shutdown state.

When the auto-restart is disabled, the shutdown state will persist as long as the SHUTDOWN bit is set.

When auto-restart is enabled, the SHUTDOWN bit will clear automatically and resume operation on the next rising edge event.

20.10.2 EXTERNAL INPUT SOURCE

External shutdown inputs provide the fastest way to safely suspend CWG operation in the event of a Fault condition. When any of the selected shutdown inputs goes active, the CWG outputs will immediately go to the selected override levels without software delay. Several input sources can be selected to cause a shutdown condition. All input sources are active-low. The sources are:

- Comparator C1OUT_sync
- Comparator C2OUT_sync
- Timer2 – TMR2_postscaled
- Timer4 – TMR4_postscaled
- Timer6 – TMR6_postscaled
- CWGxIN input pin

Shutdown inputs are selected using the CWGxAS1 register ([Register 20-6](#)).

<p>Note: Shutdown inputs are level sensitive, not edge sensitive. The shutdown state cannot be cleared, except by disabling auto-shutdown, as long as the shutdown input level persists.</p>

20.11 Operation During Sleep

The CWG module operates independently from the system clock and will continue to run during Sleep, provided that the clock and input sources selected remain active.

The HFINTOSC remains active during Sleep when all the following conditions are met:

- CWG module is enabled
- Input source is active
- HFINTOSC is selected as the clock source, regardless of the system clock source selected.

In other words, if the HFINTOSC is simultaneously selected as the system clock and the CWG clock source, when the CWG is enabled and the input source is active, then the CPU will go idle during Sleep, but the HFINTOSC will remain active and the CWG will continue to operate. This will have a direct effect on the Sleep mode current.

FIGURE 20-12: CWG SHUTDOWN BLOCK DIAGRAM

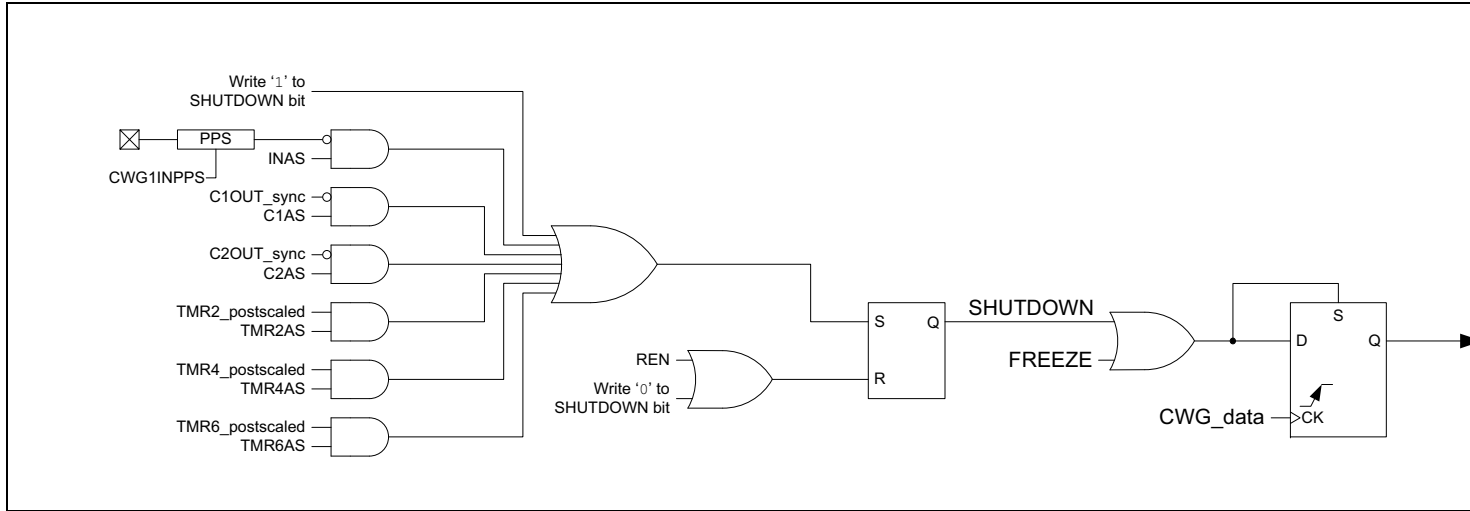

20.12 Configuring the CWG

The following steps illustrate how to properly configure the CWG.

1. Ensure that the TRIS control bits corresponding to the desired CWG pins for your application are set so that the pins are configured as inputs.
2. Clear the EN bit, if not already cleared.
3. Set desired mode of operation with the MODE bits.
4. Set desired dead-band times, if applicable to mode, with the CWGxDBR and CWGxDBF registers.
5. Setup the following controls in the CWGxAS0 and CWGxAS1 registers.
 - a. Select the desired shutdown source.
 - b. Select both output overrides to the desired levels (this is necessary even if not using auto-shutdown because start-up will be from a shutdown state).
 - c. Set which pins will be affected by auto-shutdown with the CWGxAS1 register.
 - d. Set the SHUTDOWN bit and clear the REN bit.
6. Select the desired input source using the CWGxISM register.
7. Configure the following controls.
 - a. Select desired clock source using the CWGxCLKCON register.
 - b. Select the desired output polarities using the CWGxCON1 register.
 - c. Set the output enables for the desired outputs.
8. Set the EN bit.
9. Clear TRIS control bits corresponding to the desired output pins to configure these pins as outputs.
10. If auto-restart is to be used, set the REN bit and the SHUTDOWN bit will be cleared automatically. Otherwise, clear the SHUTDOWN bit to start the CWG.

20.12.1 PIN OVERRIDE LEVELS

The levels driven to the output pins, while the shutdown input is true, are controlled by the LSB and LSAC bits of the CWGxAS0 register. LSB<1:0> controls the CWGxB and D override levels and LSAC<1:0> controls the CWGxA and C override levels. The control bit logic level corresponds to the output logic drive level while in the shutdown state. The polarity control does not affect the override level.

20.12.2 AUTO-SHUTDOWN RESTART

After an auto-shutdown event has occurred, there are two ways to resume operation:

- Software controlled
- Auto-restart

The restart method is selected with the REN bit of the CWGxCON2 register. Waveforms of software controlled and automatic restarts are shown in [Figure 20-13](#) and [Figure 20-14](#).

20.12.2.1 Software Controlled Restart

When the REN bit of the CWGxAS0 register is cleared, the CWG must be restarted after an auto-shutdown event by software. Clearing the shutdown state requires all selected shutdown inputs to be low, otherwise the SHUTDOWN bit will remain set. The overrides will remain in effect until the first rising edge event after the SHUTDOWN bit is cleared. The CWG will then resume operation.

20.12.2.2 Auto-Restart

When the REN bit of the CWGxCON2 register is set, the CWG will restart from the auto-shutdown state automatically. The SHUTDOWN bit will clear automatically when all shutdown sources go low. The overrides will remain in effect until the first rising edge event after the SHUTDOWN bit is cleared. The CWG will then resume operation.

FIGURE 20-13: SHUTDOWN FUNCTIONALITY, AUTO-RESTART DISABLED (REN = 0, LSAC = 01, LSBD = 01)

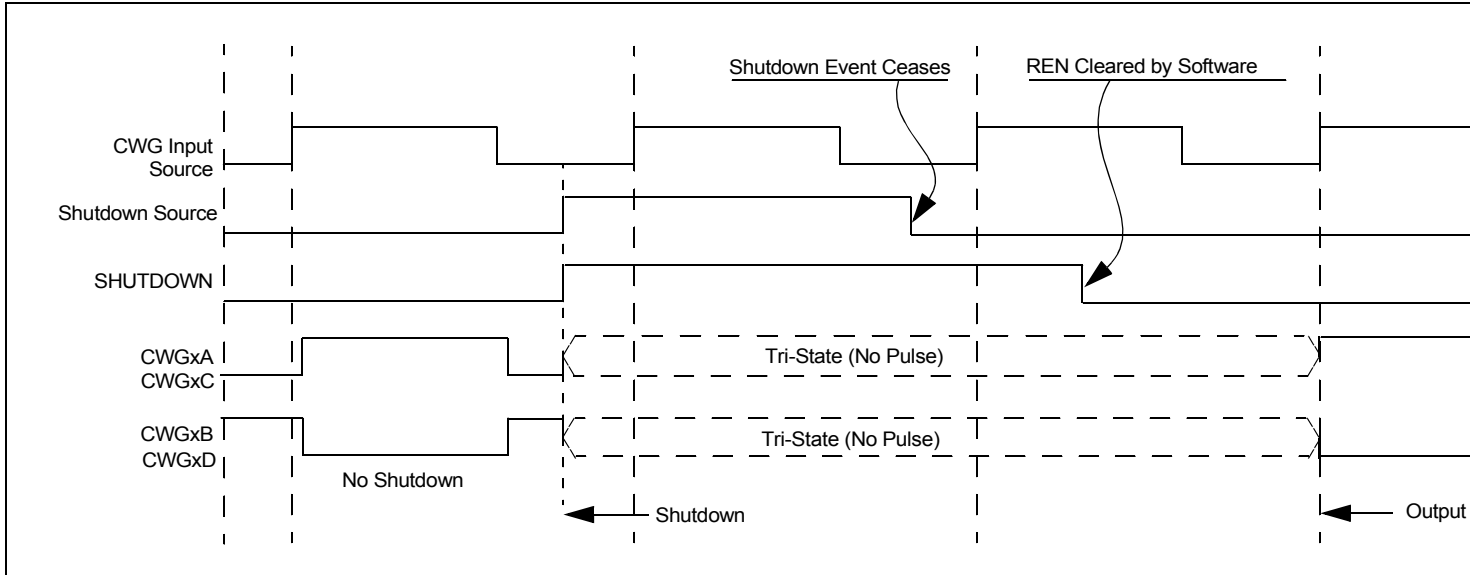
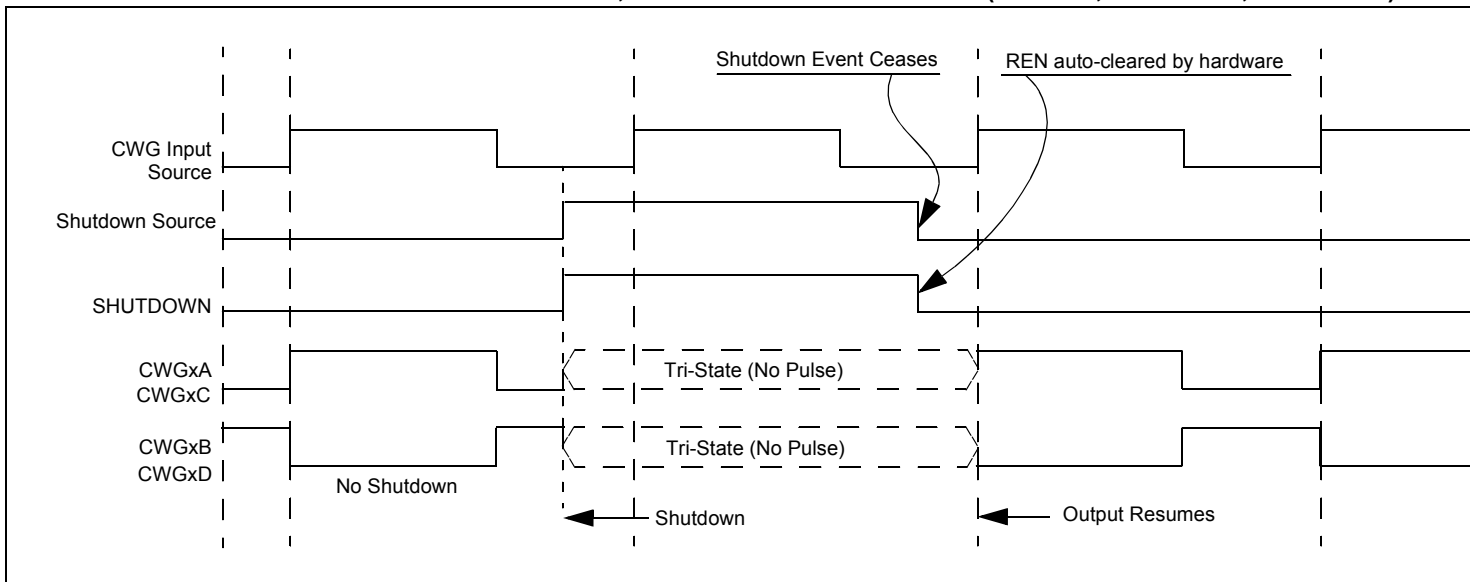

FIGURE 20-14: SHUTDOWN FUNCTIONALITY, AUTO-RESTART ENABLED (REN = 1, LSAC = 01, LSBD = 01)



PIC16(L)F18856/76

20.13 Register Definitions: CWG Control

Long bit name prefixes for the CWG peripherals are shown in [Section 1.1 “Register and Bit naming conventions”](#).

TABLE 20-3: LONG BIT NAMES PREFIXES FOR CWG PERIPHERALS

Peripheral	Bit Name Prefix
CWG1	CWG1
CWG2	CWG2
CWG3	CWG3

REGISTER 20-1: CWGxCON0: CWGx CONTROL REGISTER 0

R/W-0/0	R/W/HC-0/0	U-0	U-0	U-0	R/W-0/0	R/W-0/0	R/W-0/0
EN	LD ⁽¹⁾	—	—	—	MODE<2:0>		
bit 7							bit 0

Legend:

HC = Bit is cleared by hardware

HS = Bit is set by hardware

R = Readable bit

W = Writable bit

U = Unimplemented bit, read as '0'

u = Bit is unchanged

x = Bit is unknown

-n/n = Value at POR and BOR/Value at all other Resets

'1' = Bit is set

'0' = Bit is cleared

q = Value depends on condition

- bit 7 **EN:** CWGx Enable bit
1 = Module is enabled
0 = Module is disabled
- bit 6 **LD:** CWGx Load Buffer bits⁽¹⁾
1 = Buffers to be loaded on the next rising/falling event
0 = Buffers not loaded
- bit 5-3 **Unimplemented:** Read as '0'
- bit 2-0 **MODE<2:0>:** CWGx Mode bits
111 = Reserved
110 = Reserved
101 = CWG outputs operate in Push-Pull mode
100 = CWG outputs operate in Half-Bridge mode
011 = CWG outputs operate in Reverse Full-Bridge mode
010 = CWG outputs operate in Forward Full-Bridge mode
001 = CWG outputs operate in Synchronous Steering mode
000 = CWG outputs operate in Steering mode

Note 1: This bit can only be set after EN = 1 and cannot be set in the same instruction that EN is set.

PIC16(L)F18856/76

REGISTER 20-2: CWGxCON1: CWGx CONTROL REGISTER 1

U-0	U-0	R-x	U-0	R/W-0/0	R/W-0/0	R/W-0/0	R/W-0/0
—	—	IN	—	POLD	POLC	POLB	POLA
bit 7							bit 0

Legend:

R = Readable bit

W = Writable bit

U = Unimplemented bit, read as '0'

u = Bit is unchanged

x = Bit is unknown

-n/n = Value at POR and BOR/Value at all other Resets

'1' = Bit is set

'0' = Bit is cleared

q = Value depends on condition

bit 7-6	Unimplemented: Read as '0'
bit 5	IN: CWG Input Value
bit 4	Unimplemented: Read as '0'
bit 3	POLD: CWGxD Output Polarity bit 1 = Signal output is inverted polarity 0 = Signal output is normal polarity
bit 2	POLC: CWGxC Output Polarity bit 1 = Signal output is inverted polarity 0 = Signal output is normal polarity
bit 1	POLB: CWGxB Output Polarity bit 1 = Signal output is inverted polarity 0 = Signal output is normal polarity
bit 0	POLA: CWGxA Output Polarity bit 1 = Signal output is inverted polarity 0 = Signal output is normal polarity

PIC16(L)F18856/76

REGISTER 20-3: CWGxDBR: CWGx RISING DEAD-BAND COUNTER REGISTER

U-0	U-0	R/W-x/u	R/W-x/u	R/W-x/u	R/W-x/u	R/W-x/u	R/W-x/u
—	—	DBR<5:0>					
bit 7							bit 0

Legend:

R = Readable bit	W = Writable bit	U = Unimplemented bit, read as '0'
u = Bit is unchanged	x = Bit is unknown	-n/n = Value at POR and BOR/Value at all other Resets
'1' = Bit is set	'0' = Bit is cleared	q = Value depends on condition

bit 7-6 **Unimplemented:** Read as '0'

bit 5-0 **DBR<5:0>:** Rising Event Dead-Band Value for Counter bits

REGISTER 20-4: CWGxDBF: CWGx FALLING DEAD-BAND COUNTER REGISTER

U-0	U-0	R/W-x/u	R/W-x/u	R/W-x/u	R/W-x/u	R/W-x/u	R/W-x/u
—	—	DBF<5:0>					
bit 7							bit 0

Legend:

R = Readable bit	W = Writable bit	U = Unimplemented bit, read as '0'
u = Bit is unchanged	x = Bit is unknown	-n/n = Value at POR and BOR/Value at all other Resets
'1' = Bit is set	'0' = Bit is cleared	q = Value depends on condition

bit 7-6 **Unimplemented:** Read as '0'

bit 5-0 **DBF<5:0>:** Falling Event Dead-Band Value for Counter bits

PIC16(L)F18856/76

REGISTER 20-5: CWGxAS0: CWGx AUTO-SHUTDOWN CONTROL REGISTER 0

R/W/HS-0/0	R/W-0/0	R/W-0/0	R/W-1/1	R/W-0/0	R/W-1/1	U-0	U-0
SHUTDOWN ^(1,2)	REN	LSBD<1:0>		LSAC<1:0>		—	—
bit 7						bit 0	

Legend:

HC = Bit is cleared by hardware

HS = Bit is set by hardware

R = Readable bit

W = Writable bit

U = Unimplemented bit, read as '0'

u = Bit is unchanged

x = Bit is unknown

-n/n = Value at POR and BOR/Value at all other Resets

'1' = Bit is set

'0' = Bit is cleared

q = Value depends on condition

bit 7 **SHUTDOWN:** Auto-Shutdown Event Status bit^(1,2)

1 = An Auto-Shutdown state is in effect

0 = No Auto-shutdown event has occurred

bit 6 **REN:** Auto-Restart Enable bit

1 = Auto-restart enabled

0 = Auto-restart disabled

bit 5-4 **LSBD<1:0>:** CWGxB and CWGxD Auto-Shutdown State Control bits

11 = A logic '1' is placed on CWGxB/D when an auto-shutdown event is present

10 = A logic '0' is placed on CWGxB/D when an auto-shutdown event is present

01 = Pin is tri-stated on CWGxB/D when an auto-shutdown event is present

00 = The inactive state of the pin, including polarity, is placed on CWGxB/D after the required dead-band interval

bit 3-2 **LSAC<1:0>:** CWGxA and CWGxC Auto-Shutdown State Control bits

11 = A logic '1' is placed on CWGxA/C when an auto-shutdown event is present

10 = A logic '0' is placed on CWGxA/C when an auto-shutdown event is present

01 = Pin is tri-stated on CWGxA/C when an auto-shutdown event is present

00 = The inactive state of the pin, including polarity, is placed on CWGxA/C after the required dead-band interval

bit 1-0 **Unimplemented:** Read as '0'

Note 1: This bit may be written while EN = 0 (CWGxCON0 register) to place the outputs into the shutdown configuration.

2: The outputs will remain in auto-shutdown state until the next rising edge of the input signal after this bit is cleared.

PIC16(L)F18856/76

REGISTER 20-6: CWGxAS1: CWGx AUTO-SHUTDOWN CONTROL REGISTER 1

U-1	R/W-0/0	R/W-0/0	R/W-0/0	R/W-0/0	R/W-0/0	R/W-0/0	R/W-0/0
—	AS6E	AS5E	AS4E	AS3E	AS2E	AS1E	AS0E
bit 7							bit 0

Legend:

R = Readable bit	W = Writable bit	U = Unimplemented bit, read as '0'
u = Bit is unchanged	x = Bit is unknown	-n/n = Value at POR and BOR/Value at all other Resets
'1' = Bit is set	'0' = Bit is cleared	q = Value depends on condition

- bit 7 **Unimplemented:** Read as '1'
- bit 6 **AS6E:** CLC2 Output bit
 1 = LC2_out shut down is enabled
 0 = LC2_out shut down is disabled
- bit 5 **AS5E:** Comparator C2 Output bit
 1 = C2 output shut-down is enabled
 0 = C2 output shut-down is disabled
- bit 4 **AS4E:** Comparator C1 Output bit
 1 = C1 output shut-down is enabled
 0 = C1 output shut-down is disabled
- bit 3 **AS3E:** TMR6 Postscale Output bit
 1 = TMR6 output shut-down is enabled
 0 = TMR6 output shut-down is disabled
- bit 2 **AS2E:** TMR4 Postscale Output bit
 1 = TMR4 output shut-down is enabled
 0 = TMR4 output shut-down is disabled
- bit 2 **AS1E:** TMR2 Postscale Output bit
 1 = TMR2 Postscale shut-down is enabled
 0 = TMR2 Postscale shut-down is disabled
- bit 0 **AS0E:** CWGx Input Pin bit
 1 = Input pin selected by CWGxPPS shut-down is enabled
 0 = Input pin selected by CWGxPPS shut-down is disabled

PIC16(L)F18856/76

REGISTER 20-7: CWGxSTR: CWGx STEERING CONTROL REGISTER⁽¹⁾

R/W-0/0	R/W-0/0	R/W-0/0	R/W-0/0	R/W-0/0	R/W-0/0	R/W-0/0	R/W-0/0
OVRD	OVRC	OVRB	OVRA	STRD ⁽²⁾	STRC ⁽²⁾	STRB ⁽²⁾	STRA ⁽²⁾
bit 7							bit 0

Legend:

R = Readable bit	W = Writable bit	U = Unimplemented bit, read as '0'
u = Bit is unchanged	x = Bit is unknown	-n/n = Value at POR and BOR/Value at all other Resets
'1' = Bit is set	'0' = Bit is cleared	q = Value depends on condition

bit 7	OVRD: Steering Data D bit
bit 6	OVRC: Steering Data C bit
bit 5	OVRB: Steering Data B bit
bit 4	OVRA: Steering Data A bit
bit 3	STRD: Steering Enable D bit ⁽²⁾ 1 = CWGxD output has the CWGx_data waveform with polarity control from POLD bit 0 = CWGxD output is assigned the value of OVRD bit
bit 2	STRC: Steering Enable C bit ⁽²⁾ 1 = CWGxC output has the CWGx_data waveform with polarity control from POLC bit 0 = CWGxC output is assigned the value of OVRC bit
bit 1	STRB: Steering Enable B bit ⁽²⁾ 1 = CWGxB output has the CWGx_data waveform with polarity control from POLB bit 0 = CWGxB output is assigned the value of OVRB bit
bit 0	STRA: Steering Enable A bit ⁽²⁾ 1 = CWGxA output has the CWGx_data waveform with polarity control from POLA bit 0 = CWGxA output is assigned the value of OVRA bit

Note 1: The bits in this register apply only when MODE<2:0> = 00x.

2: This bit is effectively double-buffered when MODE<2:0> = 001.

PIC16(L)F18856/76

REGISTER 20-8: CWGxCLK: CWGx CLOCK SELECTION REGISTER

U-0	U-0	U-0	U-0	U-0	U-0	U-0	R/W-0/0
—	—	—	—	—	—	—	CS
bit 7							bit 0

Legend:

R = Readable bit	W = Writable bit	U = Unimplemented bit, read as '0'
u = Bit is unchanged	x = Bit is unknown	-n/n = Value at POR and BOR/Value at all other Resets
'1' = Bit is set	'0' = Bit is cleared	q = Value depends on condition

bit 7-1 **Unimplemented:** Read as '0'

bit 0 **CS:** CWGx Clock Selection bit
 1 = HFINTOSC 16 MHz is selected
 0 = FOSC is selected

REGISTER 20-9: CWGxISM: CWGx INPUT SELECTION REGISTER

U-0	U-0	U-0	U-0	R/W-0/0	R/W-0/0	R/W-0/0	R/W-0/0
—	—	—	—	IS<3:0>			
bit 7							bit 0

Legend:

R = Readable bit	W = Writable bit	U = Unimplemented bit, read as '0'
u = Bit is unchanged	x = Bit is unknown	-n/n = Value at POR and BOR/Value at all other Resets
'1' = Bit is set	'0' = Bit is cleared	q = Value depends on condition

bit 7-4 **Unimplemented:** Read as '0'

bit 3-0 **IS<3:0>:** CWGx Input Selection bits

1111 = LC4_out
 1110 = LC3_out
 1101 = LC2_out
 1100 = LC1_out
 1011 = DSM_out
 1010 = C2OUT_sync
 1001 = C1OUT_sync
 1000 = NCO1_out
 0111 = PWM7_out
 0110 = PWM6_out
 0101 = CCP5_out
 0100 = CCP4_out
 0011 = CCP3_out
 0010 = CCP2_out
 0001 = CCP1_out
 0000 = CWGxINPPS

PIC16(L)F18856/76

TABLE 20-4: SUMMARY OF REGISTERS ASSOCIATED WITH CWG

Name	Bit 7	Bit 6	Bit 5	Bit 4	Bit 3	Bit 2	Bit 1	Bit 0	Register on Page
CWG1CLKCON	—	—	—	—	—	—	—	CS	312
CWG1ISM	—	—	—	—	IS<3:0>				312
CWG1DBR	—	—	DBR<5:0>						308
CWG1DBF	—	—	DBF<5:0>						308
CWG1CON0	EN	LD	—	—	—	MODE<2:0>			311
CWG1CON1	—	—	IN	—	POLD	POLC	POLB	POLA	307
CWG1AS0	SHUTDOWN	REN	LSBD<1:0>		LSAC<1:0>		—	—	309
CWG1AS1	—	AS6E	AS5E	AS4E	AS3E	AS2E	AS1E	AS0E	310
CWG1STR	OVRD	OVRTC	OVRB	OVRTA	STRD	STRC	STRB	STRA	311
CWG2CLKCON	—	—	—	—	—	—	—	CS	312
CWG2ISM	—	—	—	—	IS<3:0>				312
CWG2DBR	—	—	DBR<5:0>						308
CWG2DBF	—	—	DBF<5:0>						308
CWG2CON0	EN	LD	—	—	—	MODE<2:0>			311
CWG2CON1	—	—	IN	—	POLD	POLC	POLB	POLA	307
CWG2AS0	SHUTDOWN	REN	LSBD<1:0>		LSAC<1:0>		—	—	309
CWG2AS1	—	AS6E	AS5E	AS4E	AS3E	AS2E	AS1E	AS0E	310
CWG2STR	OVRD	OVRTC	OVRB	OVRTA	STRD	STRC	STRB	STRA	311
CWG3CLKCON	—	—	—	—	—	—	—	CS	312
CWG3ISM	—	—	—	—	IS<3:0>				312
CWG3DBR	—	—	DBR<5:0>						308
CWG3DBF	—	—	DBF<5:0>						308
CWG3CON0	EN	LD	—	—	—	MODE<2:0>			311
CWG3CON1	—	—	IN	—	POLD	POLC	POLB	POLA	307
CWG3AS0	SHUTDOWN	REN	LSBD<1:0>		LSAC<1:0>		—	—	309
CWG3AS1	—	AS6E	AS5E	AS4E	AS3E	AS2E	AS1E	AS0E	310
CWG3STR	OVRD	OVRTC	OVRB	OVRTA	STRD	STRC	STRB	STRA	311

Legend: — = unimplemented locations read as '0'. Shaded cells are not used by CWG.

PIC16(L)F18856/76

21.0 ZERO-CROSS DETECTION (ZCD) MODULE

The ZCD module detects when an A/C signal crosses through the ground potential. The actual zero crossing threshold is the zero crossing reference voltage, V_{CPINV} , which is typically 0.75V above ground.

The connection to the signal to be detected is through a series current limiting resistor. The module applies a current source or sink to the ZCD pin to maintain a constant voltage on the pin, thereby preventing the pin voltage from forward biasing the ESD protection diodes. When the applied voltage is greater than the reference voltage, the module sinks current. When the applied voltage is less than the reference voltage, the module sources current. The current source and sink action keeps the pin voltage constant over the full range of the applied voltage. The ZCD module is shown in the simplified block diagram [Figure 21-2](#).

The ZCD module is useful when monitoring an A/C waveform for, but not limited to, the following purposes:

- A/C period measurement
- Accurate long term time measurement
- Dimmer phase delayed drive
- Low EMI cycle switching

21.1 External Resistor Selection

The ZCD module requires a current limiting resistor in series with the external voltage source. The impedance and rating of this resistor depends on the external source peak voltage. Select a resistor value that will drop all of the peak voltage when the current through the resistor is nominally 300 μ A. Refer to [Equation 21-1](#) and [Figure 21-1](#). Make sure that the ZCD I/O pin internal weak pull-up is disabled so it does not interfere with the current source and sink.

EQUATION 21-1: EXTERNAL RESISTOR

$$R_{SERIES} = \frac{V_{PEAK}}{3 \times 10^{-4}}$$

FIGURE 21-1: EXTERNAL VOLTAGE

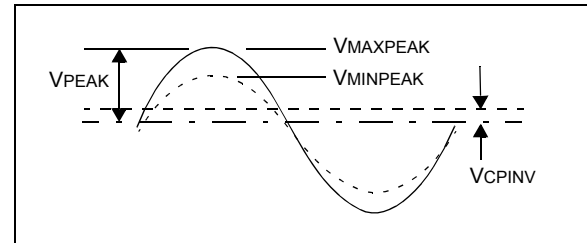

PIC16(L)F18856/76

FIGURE 21-2: SIMPLIFIED ZCD BLOCK DIAGRAM

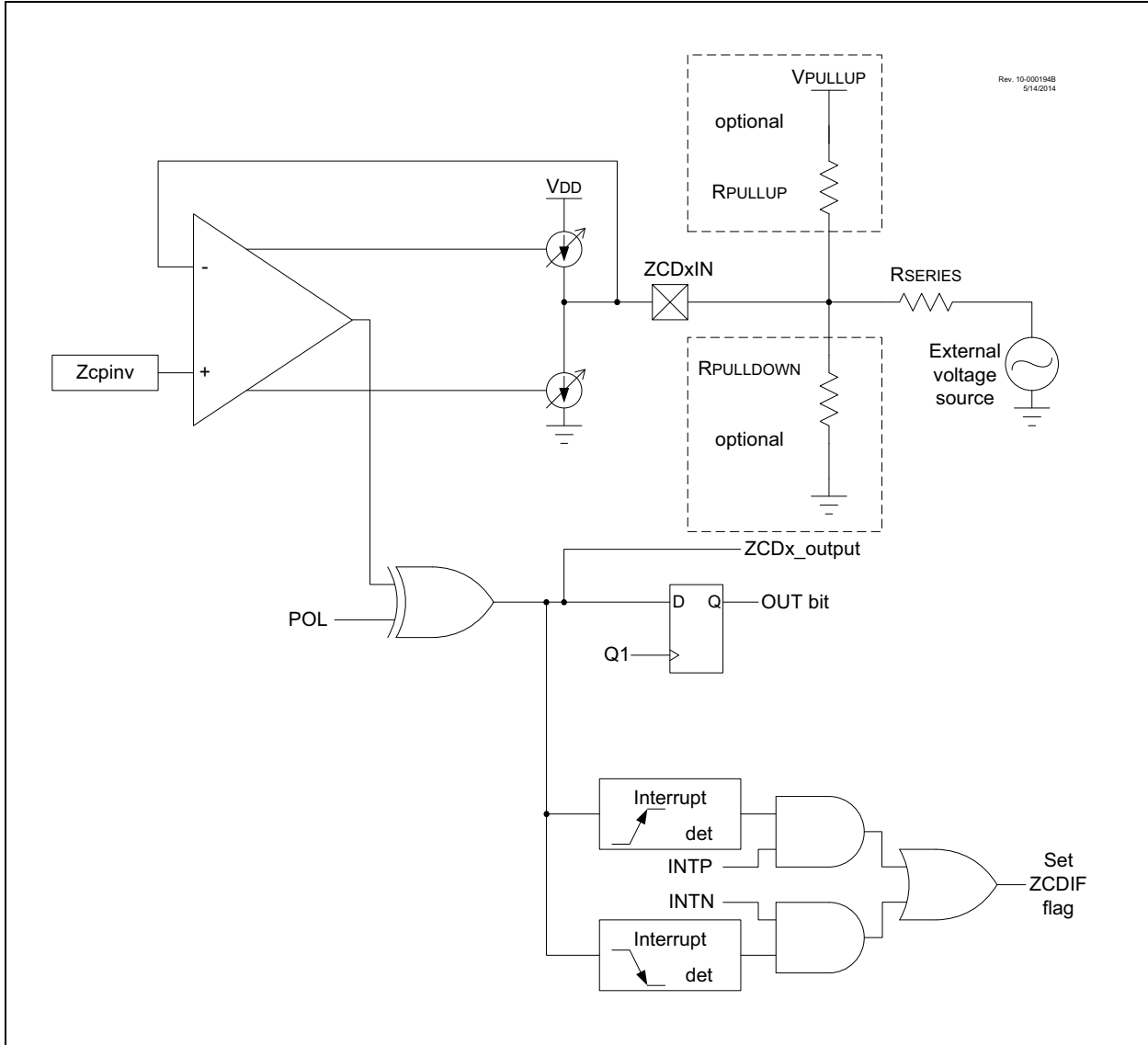

21.2 ZCD Logic Output

The ZCD module includes a Status bit, which can be read to determine whether the current source or sink is active. The OUT bit of the ZCDxCON register is set when the current sink is active, and cleared when the current source is active. The OUT bit is affected by the polarity bit.

21.3 ZCD Logic Polarity

The POL bit of the ZCDxCON register inverts the ZCDxOUT bit relative to the current source and sink output. When the POL bit is set, a OUT high indicates that the current source is active, and a low output indicates that the current sink is active.

The POL bit affects the ZCD interrupts. See [Section 21.4 “ZCD Interrupts”](#).

21.4 ZCD Interrupts

An interrupt will be generated upon a change in the ZCD logic output when the appropriate interrupt enables are set. A rising edge detector and a falling edge detector are present in the ZCD for this purpose.

The ZCDIF bit of the PIR2 register will be set when either edge detector is triggered and its associated enable bit is set. The INTP enables rising edge interrupts and the INTN bit enables falling edge interrupts. Both are located in the ZCDxCON register.

To fully enable the interrupt, the following bits must be set:

- ZCDIE bit of the PIE2 register
- INTP bit of the ZCDxCON register (for a rising edge detection)
- INTN bit of the ZCDxCON register (for a falling edge detection)
- PEIE and GIE bits of the INTCON register

Changing the POL bit will cause an interrupt, regardless of the level of the EN bit.

The ZCDIF bit of the PIR2 register must be cleared in software as part of the interrupt service. If another edge is detected while this flag is being cleared, the flag will still be set at the end of the sequence.

21.5 Correcting for VCPINV offset

The actual voltage at which the ZCD switches is the reference voltage at the non-inverting input of the ZCD op amp. For external voltage source waveforms other than square waves, this voltage offset from zero causes the zero-cross event to occur either too early or too late.

21.5.1 CORRECTION BY AC COUPLING

When the external voltage source is sinusoidal, the effects of the ZCPINV offset can be eliminated by isolating the external voltage source from the ZCD pin with a capacitor, in addition to the voltage reducing resistor. The capacitor will cause a phase shift resulting in the ZCD output switch in advance of the actual zero crossing event. The phase shift will be the same for both rising and falling zero crossings, which can be compensated for by either delaying the CPU response to the ZCD switch by a timer or other means, or selecting a capacitor value large enough that the phase shift is negligible.

To determine the series resistor and capacitor values for this configuration, start by computing the impedance, Z , to obtain a peak current of 300 μA . Next, arbitrarily select a suitably large non-polar capacitor and compute its reactance, X_c , at the external voltage source frequency. Finally, compute the series resistor, capacitor peak voltage, and phase shift by the formulas shown in [Equation 21-2](#).

When this technique is used and the input signal is not present, the ZCD will tend to oscillate. To avoid this oscillation, connect the ZCD pin to V_{DD} or GND with a high-impedance resistor such as 200K.

PIC16(L)F18856/76

EQUATION 21-2: R-C CALCULATIONS

V_{PEAK} = External voltage source peak voltage
 f = External voltage source frequency
 C = Series capacitor
 R = Series resistor
 V_C = Peak capacitor voltage
 Φ = Capacitor induced zero crossing phase advance in radians
 T_Φ = Time ZC event occurs before actual zero crossing

$$Z = \frac{V_{PEAK}}{3 \times 10^{-4}}$$

$$X_C = \frac{1}{2\pi fC}$$

$$R = \sqrt{Z^2 - X_C^2}$$

$$V_C = X_C(3 \times 10^{-4})$$

$$\Phi = \tan^{-1}\left(\frac{X_C}{R}\right)$$

$$T_\Phi = \frac{\Phi}{2\pi f}$$

EXAMPLE 21-1: R-C CALCULATIONS

$V_{RMS} = 120$
 $V_{PEAK} = V_{RMS} \times \sqrt{2} = 169.7$
 $f = 60 \text{ Hz}$
 $C = 0.1 \mu\text{F}$

$$Z = \frac{V_{PEAK}}{3 \times 10^{-4}} = \frac{169.7}{3 \times 10^{-4}} = 565.7 \text{ k}\Omega$$

$$X_C = \frac{1}{2\pi fC} = \frac{1}{(2\pi \times 60 \times 1 \times 10^{-7})} = 26.53 \text{ k}\Omega$$

$$R = \sqrt{(Z^2 - X_C^2)} = 565.1 \text{ k}\Omega \text{ (computed)}$$

$$R = 560 \text{ k}\Omega \text{ (used)}$$

$$Z_R = \sqrt{R^2 + X_C^2} = 560.6 \text{ k}\Omega \text{ (using actual resistor)}$$

$$I_{PEAK} = \frac{V_{PEAK}}{Z_R} = 302.7 \times 10^{-6}$$

$$V_C = X_C \times I_{peak} = 8.0 \text{ V}$$

$$\Phi = \tan^{-1}\left(\frac{X_C}{R}\right) = 0.047 \text{ radians}$$

$$T_\Phi = \frac{\Phi}{2\pi f} = 125.6 \mu\text{s}$$

21.5.2 CORRECTION BY OFFSET CURRENT

When the waveform is varying relative to V_{SS} , then the zero cross is detected too early as the waveform falls and too late as the waveform rises. When the waveform is varying relative to V_{DD} , then the zero cross is detected too late as the waveform rises and too early as the waveform falls. The actual offset time can be determined for sinusoidal waveforms with the corresponding equations shown in [Equation 21-3](#).

EQUATION 21-3: ZCD EVENT OFFSET

When External Voltage Source is relative to V_{SS} :

$$T_{OFFSET} = \frac{\text{asin}\left(\frac{V_{Cpinv}}{V_{PEAK}}\right)}{2\pi \cdot \text{Freq}}$$

When External Voltage Source is relative to V_{DD} :

$$T_{OFFSET} = \frac{\text{asin}\left(\frac{V_{DD} - V_{Cpinv}}{V_{PEAK}}\right)}{2\pi \cdot \text{Freq}}$$

This offset time can be compensated for by adding a pull-up or pull-down biasing resistor to the ZCD pin. A pull-up resistor is used when the external voltage source is varying relative to V_{SS} . A pull-down resistor is used when the voltage is varying relative to V_{DD} . The resistor adds a bias to the ZCD pin so that the target external voltage source must go to zero to pull the pin voltage to the V_{Cpinv} switching voltage. The pull-up or pull-down value can be determined with the equations shown in [Equation 21-4](#).

EQUATION 21-4: ZCD PULL-UP/DOWN

When External Signal is relative to V_{SS} :

$$R_{PULLUP} = \frac{R_{SERIES}(V_{PULLUP} - V_{Cpinv})}{V_{Cpinv}}$$

When External Signal is relative to V_{DD} :

$$R_{PULLDOWN} = \frac{R_{SERIES}(V_{Cpinv})}{(V_{DD} - V_{Cpinv})}$$

21.6 Handling VPEAK variations

If the peak amplitude of the external voltage is expected to vary, the series resistor must be selected to keep the ZCD current source and sink below the design maximum range of $\pm 600 \mu\text{A}$ and above a reasonable minimum range. A general rule of thumb is that the maximum peak voltage can be no more than six times the minimum peak voltage. To ensure that the maximum current does not exceed $\pm 600 \mu\text{A}$ and the minimum is at least $\pm 100 \mu\text{A}$, compute the series resistance as shown in [Equation 21-5](#). The compensating pull-up for this series resistance can be determined with [Equation 21-4](#) because the pull-up value is independent from the peak voltage.

EQUATION 21-5: SERIES R FOR V RANGE

$$R_{SERIES} = \frac{V_{MAXPEAK} + V_{MINPEAK}}{7 \times 10^{-4}}$$

21.7 Operation During Sleep

The ZCD current sources and interrupts are unaffected by Sleep.

21.8 Effects of a Reset

The ZCD circuit can be configured to default to the active or inactive state on Power-On-Reset (POR). When the ZCDDIS Configuration bit is cleared, the ZCD circuit will be active at POR. When the $\overline{\text{ZCD}}$ Configuration bit is set, the EN bit of the ZCDxCON register must be set to enable the ZCD module.

21.9 Disabling the ZCD Module

The ZCD module can be disabled in two ways:

1. Configuration Word 2H has the $\overline{\text{ZCD}}$ bit, which disables the ZCD module when set, but it can be enabled using the EN bit of the ZCDxCON register ([Register 21-1](#)). If the $\overline{\text{ZCD}}$ bit is clear, the ZCD is always enabled.
2. The ZCD can also be disabled using the ZCDMD bit of the PMD2 register ([Register 14-3](#)) this is subject to the status of the $\overline{\text{ZCD}}$ bit.

PIC16(L)F18856/76

21.10 Register Definitions: ZCD Control

REGISTER 21-1: ZCDCON: ZERO-CROSS DETECTION CONTROL REGISTER

R/W-q/q	U-0	R-x/x	R/W-0/0	U-0	U-0	R/W-0/0	R/W-0/0
EN	—	OUT	POL	—	—	INTP	INTN
bit 7							bit 0

Legend:

R = Readable bit	W = Writable bit	U = Unimplemented bit, read as '0'
u = Bit is unchanged	x = Bit is unknown	-n/n = Value at POR and BOR/Value at all other Resets
'1' = Bit is set	'0' = Bit is cleared	q = value depends on configuration bits

bit 7	EN: Zero-Cross Detection Enable bit 1 = Zero-cross detect is enabled. ZCD pin is forced to output to source and sink current. 0 = Zero-cross detect is disabled. ZCD pin operates according to PPS and TRIS controls.
bit 6	Unimplemented: Read as '0'
bit 5	OUT: Zero-Cross Detection Logic Level bit <u>POL bit = 1:</u> 1 = ZCD pin is sourcing current 0 = ZCD pin is sinking current <u>POL bit = 0:</u> 1 = ZCD pin is sinking current 0 = ZCD pin is sourcing current
bit 4	POL: Zero-Cross Detection Logic Output Polarity bit 1 = ZCD logic output is inverted 0 = ZCD logic output is not inverted
bit 3-2	Unimplemented: Read as '0'
bit 1	INTP: Zero-Cross Positive Edge Interrupt Enable bit 1 = ZCDIF bit is set on low-to-high ZCDx_output transition 0 = ZCDIF bit is unaffected by low-to-high ZCDx_output transition
bit 0	INTN: Zero-Cross Negative Edge Interrupt Enable bit 1 = ZCDIF bit is set on high-to-low ZCDx_output transition 0 = ZCDIF bit is unaffected by high-to-low ZCDx_output transition

TABLE 21-1: SUMMARY OF REGISTERS ASSOCIATED WITH THE ZCD MODULE

Name	Bit 7	Bit 6	Bit 5	Bit 4	Bit 3	Bit 2	Bit 1	Bit 0	Register on page
PIE3	—	—	RCIE	TXIE	BCL2IE	SSP2IE	BCL1IE	SSP1IE	138
PIR3	—	—	RCIF	TXIF	BCL2IF	SSP2IF	BCL1IF	SSP1IF	147
ZCDxCON	EN	—	OUT	POL	—	—	INTP	INTN	319

Legend: — = unimplemented, read as '0'. Shaded cells are unused by the ZCD module.

TABLE 21-2: SUMMARY OF CONFIGURATION WORD WITH THE ZCD MODULE

Name	Bits	Bit -/7	Bit -/6	Bit 13/5	Bit 12/4	Bit 11/3	Bit 10/2	Bit 9/1	Bit 8/0	Register on Page
CONFIG2	13:8	DEBUG	STVREN	PPS1WAY	ZCDDIS	BORV	—	BOREN<1:0>		94
	7:0	LPBOREN	—	—	—	PWRTE	MCLRE	WRT<1:0>		

Legend: — = unimplemented location, read as '0'. Shaded cells are not used by the ZCD module.

PIC16(L)F18856/76

22.0 CONFIGURABLE LOGIC CELL (CLC)

The Configurable Logic Cell (CLCx) module provides programmable logic that operates outside the speed limitations of software execution. The logic cell takes up to 32 input signals and, through the use of configurable gates, reduces the 32 inputs to four logic lines that drive one of eight selectable single-output logic functions.

Input sources are a combination of the following:

- I/O pins
- Internal clocks
- Peripherals
- Register bits

The output can be directed internally to peripherals and to an output pin.

The CLC modules available are shown in [Table 22-1](#).

Refer to [Figure 22-1](#) for a simplified diagram showing signal flow through the CLCx.

Possible configurations include:

- Combinatorial Logic
 - AND
 - NAND
 - AND-OR
 - AND-OR-INVERT
 - OR-XOR
 - OR-XNOR
- Latches
 - S-R
 - Clocked D with Set and Reset
 - Transparent D with Set and Reset
 - Clocked J-K with Reset

TABLE 22-1: AVAILABLE CLC MODULES

Device	CLC1	CLC2	CLC3	CLC4
PIC16(L)F18856/76	•	•	•	•

Note: The CLC1, CLC2, CLC3 and CLC4 are four separate module instances of the same CLC module design. Throughout this section, the lower case 'x' in register and bit names is a generic reference to the CLC number (which should be substituted with 1, 2, 3, or 4 during code development). For example, the control register is generically described in this chapter as CLCxCON, but the actual device registers are CLC1CON, CLC2CON, CLC3CON and CLC4CON. Similarly, the LCxEN bit represents the LC1EN, LC2EN, LC3EN and LC4EN bits.

PIC16(L)F18856/76

FIGURE 22-1: CLCx SIMPLIFIED BLOCK DIAGRAM

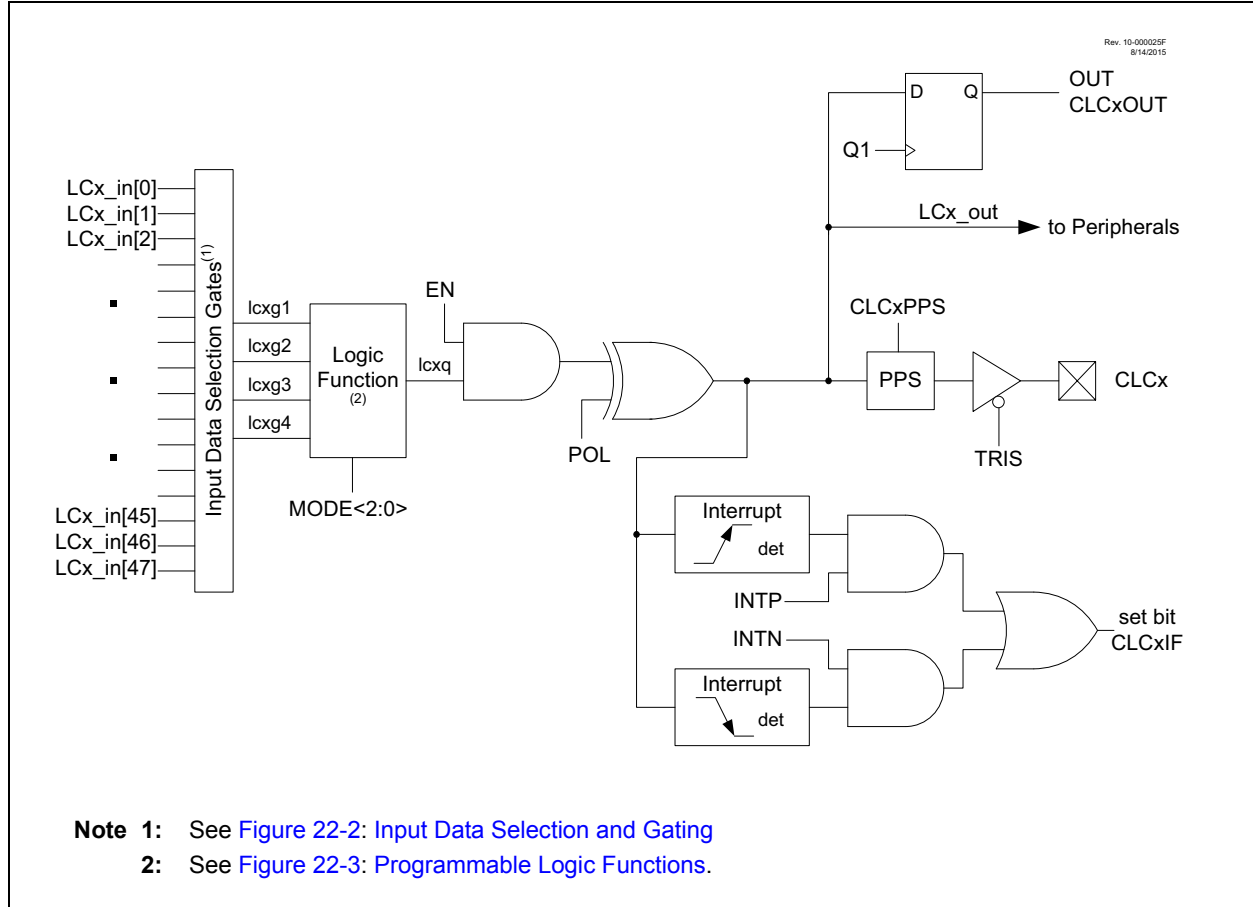

PIC16(L)F18856/76

22.1 CLCx Setup

Programming the CLCx module is performed by configuring the four stages in the logic signal flow. The four stages are:

- Data selection
- Data gating
- Logic function selection
- Output polarity

Each stage is setup at run time by writing to the corresponding CLCx Special Function Registers. This has the added advantage of permitting logic reconfiguration on-the-fly during program execution.

22.1.1 DATA SELECTION

There are 32 signals available as inputs to the configurable logic. Four 32-input multiplexers are used to select the inputs to pass on to the next stage.

Data selection is through four multiplexers as indicated on the left side of [Figure 22-2](#). Data inputs in the figure are identified by a generic numbered input name.

[Table 22-2](#) correlates the generic input name to the actual signal for each CLC module. The column labeled 'LCxDyS<4:0> Value' indicates the MUX selection code for the selected data input. LCxDyS is an abbreviation for the MUX select input codes: LCxD1S<4:0> through LCxD4S<4:0>.

Data inputs are selected with CLCxSEL0 through CLCxSEL3 registers ([Register 22-3](#) through [Register 22-6](#)).

Note: Data selections are undefined at power-up.

TABLE 22-2: CLCx DATA INPUT SELECTION

LCxDyS<4:0> Value	CLCx Input Source
110000 to 111111 [48+]	Reserved
101111 [47]	CWG3B output
101110 [46]	CWG3A output
101101 [45]	CWG2B output
101100 [44]	CWG2A output
101011 [43]	CWG1B output
101010 [42]	CWG1A output
101001 [41]	MSSP2 SCK output
101000 [40]	MSSP2 SDO output
100111 [39]	MSSP1 SCK output
100110 [38]	MSSP1 SDO output
100101 [37]	EUSART (TX/CK) output
100100 [36]	EUSART (DT) output
100011 [35]	CLC4 output
100010 [34]	CLC3 output
100001 [33]	CLC2 output
100000 [32]	CLC1 output
011111 [31]	DSM output
011110 [30]	IOCIF
011101 [29]	ZCD output
011100 [28]	Comparator 2 output
011011 [27]	Comparator 1 output
011010 [26]	NCO1 output
011001 [25]	PWM7 output
011000 [24]	PWM6 output
010111 [23]	CCP5 output
010110 [22]	CCP4 output
010101 [21]	CCP3 output
010100 [20]	CCP2 output
010011 [19]	CCP1 output
010010 [18]	SMT2 output
010001 [17]	SMT1 output
010000 [16]	TMR6 to PR6 match
001111 [15]	TMR5 overflow
001110 [14]	TMR4 to PR4 match
001101 [13]	TMR3 overflow
001100 [12]	TMR2 to PR2 match
001011 [11]	TMR1 overflow
001010 [10]	TMR0 overflow
001001 [9]	CLKR output
001000 [8]	FRC
000111 [7]	SOSC
000110 [6]	LFINTOSC
000101 [5]	HFINTOSC
000100 [4]	Fosc
000011 [3]	CLCIN3PPS
000010 [2]	CLCIN2PPS
000001 [1]	CLCIN1PPS
000000 [0]	CLCIN0PPS

PIC16(L)F18856/76

22.1.2 DATA GATING

Outputs from the input multiplexers are directed to the desired logic function input through the data gating stage. Each data gate can direct any combination of the four selected inputs.

Note: Data gating is undefined at power-up.

The gate stage is more than just signal direction. The gate can be configured to direct each input signal as inverted or non-inverted data. Directed signals are ANDed together in each gate. The output of each gate can be inverted before going on to the logic function stage.

The gating is in essence a 1-to-4 input AND/NAND/OR/NOR gate. When every input is inverted and the output is inverted, the gate is an OR of all enabled data inputs. When the inputs and output are not inverted, the gate is an AND of all enabled inputs.

Table 22-3 summarizes the basic logic that can be obtained in gate 1 by using the gate logic select bits. The table shows the logic of four input variables, but each gate can be configured to use less than four. If no inputs are selected, the output will be zero or one, depending on the gate output polarity bit.

TABLE 22-3: DATA GATING LOGIC

CLCxGLSy	LCxGyPOL	Gate Logic
0x55	1	AND
0x55	0	NAND
0xAA	1	NOR
0xAA	0	OR
0x00	0	Logic 0
0x00	1	Logic 1

It is possible (but not recommended) to select both the true and negated values of an input. When this is done, the gate output is zero, regardless of the other inputs, but may emit logic glitches (transient-induced pulses). If the output of the channel must be zero or one, the recommended method is to set all gate bits to zero and use the gate polarity bit to set the desired level.

Data gating is configured with the logic gate select registers as follows:

- Gate 1: CLCxGLS0 (Register 22-7)
- Gate 2: CLCxGLS1 (Register 22-8)
- Gate 3: CLCxGLS2 (Register 22-9)
- Gate 4: CLCxGLS3 (Register 22-10)

Register number suffixes are different than the gate numbers because other variations of this module have multiple gate selections in the same register.

Data gating is indicated in the right side of Figure 22-2. Only one gate is shown in detail. The remaining three gates are configured identically with the exception that the data enables correspond to the enables for that gate.

22.1.3 LOGIC FUNCTION

There are eight available logic functions including:

- AND-OR
- OR-XOR
- AND
- S-R Latch
- D Flip-Flop with Set and Reset
- D Flip-Flop with Reset
- J-K Flip-Flop with Reset
- Transparent Latch with Set and Reset

Logic functions are shown in Figure 22-2. Each logic function has four inputs and one output. The four inputs are the four data gate outputs of the previous stage. The output is fed to the inversion stage and from there to other peripherals, an output pin, and back to the CLCx itself.

22.1.4 OUTPUT POLARITY

The last stage in the Configurable Logic Cell is the output polarity. Setting the LCxPOL bit of the CLCxPOL register inverts the output signal from the logic stage. Changing the polarity while the interrupts are enabled will cause an interrupt for the resulting output transition.

PIC16(L)F18856/76

22.2 CLCx Interrupts

An interrupt will be generated upon a change in the output value of the CLCx when the appropriate interrupt enables are set. A rising edge detector and a falling edge detector are present in each CLC for this purpose.

The CLCxIF bit of the associated PIR5 register will be set when either edge detector is triggered and its associated enable bit is set. The LCxINTP enables rising edge interrupts and the LCxINTN bit enables falling edge interrupts. Both are located in the CLCxCON register.

To fully enable the interrupt, set the following bits:

- CLCxIE bit of the PIE5 register
- LCxINTP bit of the CLCxCON register (for a rising edge detection)
- LCxINTN bit of the CLCxCON register (for a falling edge detection)
- PEIE and GIE bits of the INTCON register

The CLCxIF bit of the PIR5 register, must be cleared in software as part of the interrupt service. If another edge is detected while this flag is being cleared, the flag will still be set at the end of the sequence.

22.3 Output Mirror Copies

Mirror copies of all LCxCON output bits are contained in the CLCxDATA register. Reading this register reads the outputs of all CLCs simultaneously. This prevents any reading skew introduced by testing or reading the LCxOUT bits in the individual CLCxCON registers.

22.4 Effects of a Reset

The CLCxCON register is cleared to zero as the result of a Reset. All other selection and gating values remain unchanged.

22.5 Operation During Sleep

The CLC module operates independently from the system clock and will continue to run during Sleep, provided that the input sources selected remain active.

The HFINTOSC remains active during Sleep when the CLC module is enabled and the HFINTOSC is selected as an input source, regardless of the system clock source selected.

In other words, if the HFINTOSC is simultaneously selected as the system clock and as a CLC input source, when the CLC is enabled, the CPU will go idle during Sleep, but the CLC will continue to operate and the HFINTOSC will remain active.

This will have a direct effect on the Sleep mode current.

22.6 CLCx Setup Steps

The following steps should be followed when setting up the CLCx:

- Disable CLCx by clearing the LCxEN bit.
- Select desired inputs using CLCxSEL0 through CLCxSEL3 registers (See [Table 22-2](#)).
- Clear any associated ANSEL bits.
- Set all TRIS bits associated with inputs.
- Clear all TRIS bits associated with outputs.
- Enable the chosen inputs through the four gates using CLCxGLS0, CLCxGLS1, CLCxGLS2, and CLCxGLS3 registers.
- Select the gate output polarities with the LCxGYPOL bits of the CLCxPOL register.
- Select the desired logic function with the LCxMODE<2:0> bits of the CLCxCON register.
- Select the desired polarity of the logic output with the LCxPOL bit of the CLCxPOL register. (This step may be combined with the previous gate output polarity step).
- If driving a device pin, set the desired pin PPS control register and also clear the TRIS bit corresponding to that output.
- If interrupts are desired, configure the following bits:
 - Set the LCxINTP bit in the CLCxCON register for rising event.
 - Set the LCxINTN bit in the CLCxCON register for falling event.
 - Set the CLCxIE bit of the PIE5 register.
 - Set the GIE and PEIE bits of the INTCON register.
- Enable the CLCx by setting the LCxEN bit of the CLCxCON register.

PIC16(L)F18856/76

FIGURE 22-2: INPUT DATA SELECTION AND GATING

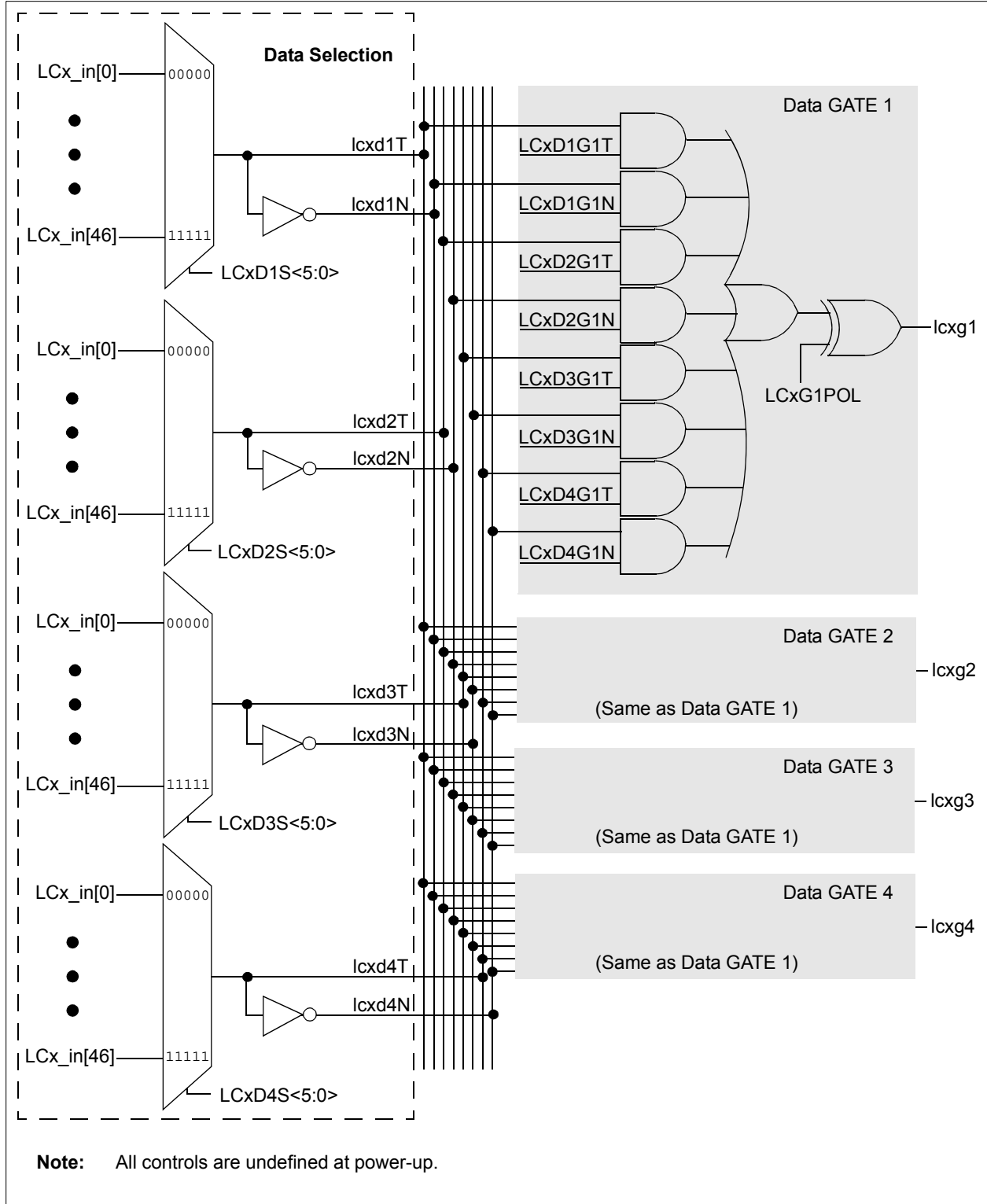

PIC16(L)F18856/76

FIGURE 22-3: PROGRAMMABLE LOGIC FUNCTIONS

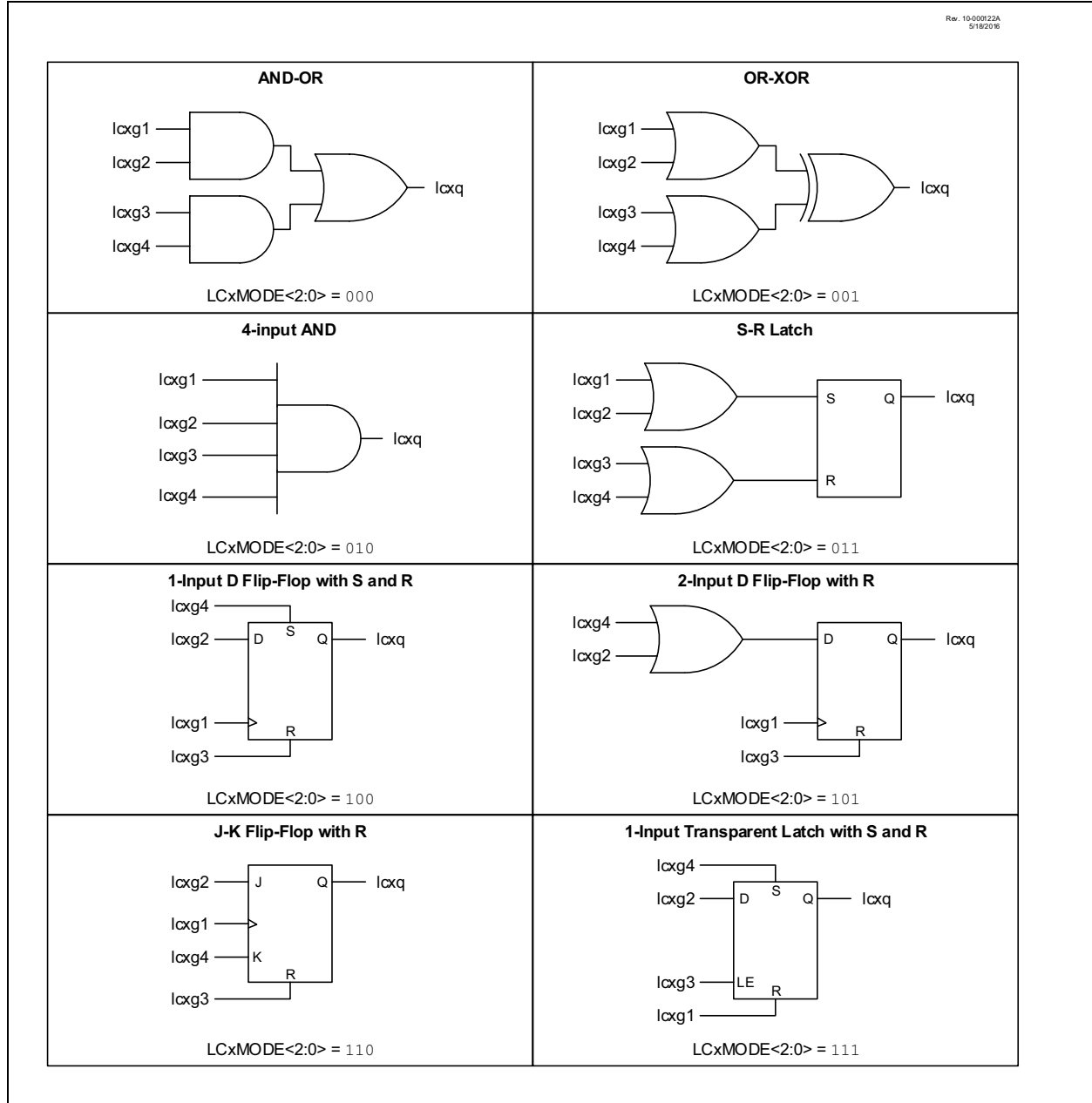

PIC16(L)F18856/76

22.7 Register Definitions: CLC Control

REGISTER 22-1: CLCxCON: CONFIGURABLE LOGIC CELL CONTROL REGISTER

R/W-0/0	U-0	R-0/0	R/W-0/0	R/W-0/0	R/W-0/0	R/W-0/0	R/W-0/0
LCxEN	—	LCxOUT	LCxINTP	LCxINTN	LCxMODE<2:0>		
bit 7							bit 0

Legend:

R = Readable bit	W = Writable bit	U = Unimplemented bit, read as '0'
u = Bit is unchanged	x = Bit is unknown	-n/n = Value at POR and BOR/Value at all other Resets
'1' = Bit is set	'0' = Bit is cleared	

- bit 7 **LCxEN:** Configurable Logic Cell Enable bit
 1 = Configurable logic cell is enabled and mixing input signals
 0 = Configurable logic cell is disabled and has logic zero output
- bit 6 **Unimplemented:** Read as '0'
- bit 5 **LCxOUT:** Configurable Logic Cell Data Output bit
 Read-only: logic cell output data, after LCPOL; sampled from CLCxOUT
- bit 4 **LCxINTP:** Configurable Logic Cell Positive Edge Going Interrupt Enable bit
 1 = CLCxIF will be set when a rising edge occurs on CLCxOUT
 0 = CLCxIF will not be set
- bit 3 **LCxINTN:** Configurable Logic Cell Negative Edge Going Interrupt Enable bit
 1 = CLCxIF will be set when a falling edge occurs on CLCxOUT
 0 = CLCxIF will not be set
- bit 2-0 **LCxMODE<2:0>:** Configurable Logic Cell Functional Mode bits
 111 = Cell is 1-input transparent latch with S and R
 110 = Cell is J-K flip-flop with R
 101 = Cell is 2-input D flip-flop with R
 100 = Cell is 1-input D flip-flop with S and R
 011 = Cell is S-R latch
 010 = Cell is 4-input AND
 001 = Cell is OR-XOR
 000 = Cell is AND-OR

PIC16(L)F18856/76

REGISTER 22-2: CLCxPOL: SIGNAL POLARITY CONTROL REGISTER

R/W-0/0	U-0	U-0	U-0	R/W-x/u	R/W-x/u	R/W-x/u	R/W-x/u
LCxPOL	—	—	—	LCxG4POL	LCxG3POL	LCxG2POL	LCxG1POL
bit 7							bit 0

Legend:

R = Readable bit	W = Writable bit	U = Unimplemented bit, read as '0'
u = Bit is unchanged	x = Bit is unknown	-n/n = Value at POR and BOR/Value at all other Resets
'1' = Bit is set	'0' = Bit is cleared	

- bit 7 **LCxPOL:** CLCxOUT Output Polarity Control bit
1 = The output of the logic cell is inverted
0 = The output of the logic cell is not inverted
- bit 6-4 **Unimplemented:** Read as '0'
- bit 3 **LCxG4POL:** Gate 3 Output Polarity Control bit
1 = The output of gate 3 is inverted when applied to the logic cell
0 = The output of gate 3 is not inverted
- bit 2 **LCxG3POL:** Gate 2 Output Polarity Control bit
1 = The output of gate 2 is inverted when applied to the logic cell
0 = The output of gate 2 is not inverted
- bit 1 **LCxG2POL:** Gate 1 Output Polarity Control bit
1 = The output of gate 1 is inverted when applied to the logic cell
0 = The output of gate 1 is not inverted
- bit 0 **LCxG1POL:** Gate 0 Output Polarity Control bit
1 = The output of gate 0 is inverted when applied to the logic cell
0 = The output of gate 0 is not inverted

PIC16(L)F18856/76

REGISTER 22-3: CLCxSEL0: GENERIC CLCx DATA 0 SELECT REGISTER

U-0	U-0	R/W-x/u	R/W-x/u	R/W-x/u	R/W-x/u	R/W-x/u	R/W-x/u
—	—	LCxD1S<5:0>					
bit 7							bit 0

Legend:

R = Readable bit W = Writable bit U = Unimplemented bit, read as '0'
u = Bit is unchanged x = Bit is unknown -n/n = Value at POR and BOR/Value at all other Resets
'1' = Bit is set '0' = Bit is cleared

bit 7-6 **Unimplemented:** Read as '0'
bit 5-0 **LCxD1S<5:0>:** CLCx Data1 Input Selection bits
See [Table 22-2](#).

REGISTER 22-4: CLCxSEL1: GENERIC CLCx DATA 1 SELECT REGISTER

U-0	U-0	R/W-x/u	R/W-x/u	R/W-x/u	R/W-x/u	R/W-x/u	R/W-x/u
—	—	LCxD2S<5:0>					
bit 7							bit 0

Legend:

R = Readable bit W = Writable bit U = Unimplemented bit, read as '0'
u = Bit is unchanged x = Bit is unknown -n/n = Value at POR and BOR/Value at all other Resets
'1' = Bit is set '0' = Bit is cleared

bit 7-6 **Unimplemented:** Read as '0'
bit 5-0 **LCxD2S<5:0>:** CLCx Data 2 Input Selection bits
See [Table 22-2](#).

REGISTER 22-5: CLCxSEL2: GENERIC CLCx DATA 2 SELECT REGISTER

U-0	U-0	R/W-x/u	R/W-x/u	R/W-x/u	R/W-x/u	R/W-x/u	R/W-x/u
—	—	LCxD3S<5:0>					
bit 7							bit 0

Legend:

R = Readable bit W = Writable bit U = Unimplemented bit, read as '0'
u = Bit is unchanged x = Bit is unknown -n/n = Value at POR and BOR/Value at all other Resets
'1' = Bit is set '0' = Bit is cleared

bit 7-6 **Unimplemented:** Read as '0'
bit 5-0 **LCxD3S<5:0>:** CLCx Data 3 Input Selection bits
See [Table 22-2](#).

REGISTER 22-6: CLCxSEL3: GENERIC CLCx DATA 3 SELECT REGISTER

U-0	U-0	R/W-x/u	R/W-x/u	R/W-x/u	R/W-x/u	R/W-x/u	R/W-x/u
—	—	LCxD4S<5:0>					
bit 7							bit 0

Legend:

R = Readable bit W = Writable bit U = Unimplemented bit, read as '0'
u = Bit is unchanged x = Bit is unknown -n/n = Value at POR and BOR/Value at all other Resets
'1' = Bit is set '0' = Bit is cleared

bit 7-6 **Unimplemented:** Read as '0'
bit 5-0 **LCxD4S<5:0>:** CLCx Data 4 Input Selection bits
See [Table 22-2](#).

PIC16(L)F18856/76

REGISTER 22-7: CLCxGLS0: GATE 0 LOGIC SELECT REGISTER

R/W-x/u	R/W-x/u	R/W-x/u	R/W-x/u	R/W-x/u	R/W-x/u	R/W-x/u	R/W-x/u
LCxG1D4T	LCxG1D4N	LCxG1D3T	LCxG1D3N	LCxG1D2T	LCxG1D2N	LCxG1D1T	LCxG1D1N
bit 7							bit 0

Legend:

R = Readable bit	W = Writable bit	U = Unimplemented bit, read as '0'
u = Bit is unchanged	x = Bit is unknown	-n/n = Value at POR and BOR/Value at all other Resets
'1' = Bit is set	'0' = Bit is cleared	

bit 7	LCxG1D4T: Gate 0 Data 4 True (non-inverted) bit 1 = CLCIN3 (true) is gated into CLCx Gate 0 0 = CLCIN3 (true) is not gated into CLCx Gate 0
bit 6	LCxG1D4N: Gate 0 Data 4 Negated (inverted) bit 1 = CLCIN3 (inverted) is gated into CLCx Gate 0 0 = CLCIN3 (inverted) is not gated into CLCx Gate 0
bit 5	LCxG1D3T: Gate 0 Data 3 True (non-inverted) bit 1 = CLCIN2 (true) is gated into CLCx Gate 0 0 = CLCIN2 (true) is not gated into CLCx Gate 0
bit 4	LCxG1D3N: Gate 0 Data 3 Negated (inverted) bit 1 = CLCIN2 (inverted) is gated into CLCx Gate 0 0 = CLCIN2 (inverted) is not gated into CLCx Gate 0
bit 3	LCxG1D2T: Gate 0 Data 2 True (non-inverted) bit 1 = CLCIN1 (true) is gated into CLCx Gate 0 0 = CLCIN1 (true) is not gated into CLCx Gate 0
bit 2	LCxG1D2N: Gate 0 Data 2 Negated (inverted) bit 1 = CLCIN1 (inverted) is gated into CLCx Gate 0 0 = CLCIN1 (inverted) is not gated into CLCx Gate 0
bit 1	LCxG1D1T: Gate 0 Data 1 True (non-inverted) bit 1 = CLCIN0 (true) is gated into CLCx Gate 0 0 = CLCIN0 (true) is not gated into CLCx Gate 0
bit 0	LCxG1D1N: Gate 0 Data 1 Negated (inverted) bit 1 = CLCIN0 (inverted) is gated into CLCx Gate 0 0 = CLCIN0 (inverted) is not gated into CLCx Gate 0

PIC16(L)F18856/76

REGISTER 22-8: CLCxGLS1: GATE 1 LOGIC SELECT REGISTER

R/W-x/u	R/W-x/u	R/W-x/u	R/W-x/u	R/W-x/u	R/W-x/u	R/W-x/u	R/W-x/u
LCxG2D4T	LCxG2D4N	LCxG2D3T	LCxG2D3N	LCxG2D2T	LCxG2D2N	LCxG2D1T	LCxG2D1N
bit 7							bit 0

Legend:

R = Readable bit	W = Writable bit	U = Unimplemented bit, read as '0'
u = Bit is unchanged	x = Bit is unknown	-n/n = Value at POR and BOR/Value at all other Resets
'1' = Bit is set	'0' = Bit is cleared	

- bit 7 **LCxG2D4T:** Gate 1 Data 4 True (non-inverted) bit
 1 = CLCIN3 (true) is gated into CLCx Gate 1
 0 = CLCIN3 (true) is not gated into CLCx Gate 1
- bit 6 **LCxG2D4N:** Gate 1 Data 4 Negated (inverted) bit
 1 = CLCIN3 (inverted) is gated into CLCx Gate 1
 0 = CLCIN3 (inverted) is not gated into CLCx Gate 1
- bit 5 **LCxG2D3T:** Gate 1 Data 3 True (non-inverted) bit
 1 = CLCIN2 (true) is gated into CLCx Gate 1
 0 = CLCIN2 (true) is not gated into CLCx Gate 1
- bit 4 **LCxG2D3N:** Gate 1 Data 3 Negated (inverted) bit
 1 = CLCIN2 (inverted) is gated into CLCx Gate 1
 0 = CLCIN2 (inverted) is not gated into CLCx Gate 1
- bit 3 **LCxG2D2T:** Gate 1 Data 2 True (non-inverted) bit
 1 = CLCIN1 (true) is gated into CLCx Gate 1
 0 = CLCIN1 (true) is not gated into CLCx Gate 1
- bit 2 **LCxG2D2N:** Gate 1 Data 2 Negated (inverted) bit
 1 = CLCIN1 (inverted) is gated into CLCx Gate 1
 0 = CLCIN1 (inverted) is not gated into CLCx Gate 1
- bit 1 **LCxG2D1T:** Gate 1 Data 1 True (non-inverted) bit
 1 = CLCIN0 (true) is gated into CLCx Gate 1
 0 = CLCIN0 (true) is not gated into CLCx Gate 1
- bit 0 **LCxG2D1N:** Gate 1 Data 1 Negated (inverted) bit
 1 = CLCIN0 (inverted) is gated into CLCx Gate 1
 0 = CLCIN0 (inverted) is not gated into CLCx Gate 1

PIC16(L)F18856/76

REGISTER 22-9: CLCxGLS2: GATE 2 LOGIC SELECT REGISTER

R/W-x/u	R/W-x/u	R/W-x/u	R/W-x/u	R/W-x/u	R/W-x/u	R/W-x/u	R/W-x/u
LCxG3D4T	LCxG3D4N	LCxG3D3T	LCxG3D3N	LCxG3D2T	LCxG3D2N	LCxG3D1T	LCxG3D1N
bit 7							bit 0

Legend:

R = Readable bit	W = Writable bit	U = Unimplemented bit, read as '0'
u = Bit is unchanged	x = Bit is unknown	-n/n = Value at POR and BOR/Value at all other Resets
'1' = Bit is set	'0' = Bit is cleared	

bit 7	LCxG3D4T: Gate 2 Data 4 True (non-inverted) bit 1 = CLCIN3 (true) is gated into CLCx Gate 2 0 = CLCIN3 (true) is not gated into CLCx Gate 2
bit 6	LCxG3D4N: Gate 2 Data 4 Negated (inverted) bit 1 = CLCIN3 (inverted) is gated into CLCx Gate 2 0 = CLCIN3 (inverted) is not gated into CLCx Gate 2
bit 5	LCxG3D3T: Gate 2 Data 3 True (non-inverted) bit 1 = CLCIN2 (true) is gated into CLCx Gate 2 0 = CLCIN2 (true) is not gated into CLCx Gate 2
bit 4	LCxG3D3N: Gate 2 Data 3 Negated (inverted) bit 1 = CLCIN2 (inverted) is gated into CLCx Gate 2 0 = CLCIN2 (inverted) is not gated into CLCx Gate 2
bit 3	LCxG3D2T: Gate 2 Data 2 True (non-inverted) bit 1 = CLCIN1 (true) is gated into CLCx Gate 2 0 = CLCIN1 (true) is not gated into CLCx Gate 2
bit 2	LCxG3D2N: Gate 2 Data 2 Negated (inverted) bit 1 = CLCIN1 (inverted) is gated into CLCx Gate 2 0 = CLCIN1 (inverted) is not gated into CLCx Gate 2
bit 1	LCxG3D1T: Gate 2 Data 1 True (non-inverted) bit 1 = CLCIN0 (true) is gated into CLCx Gate 2 0 = CLCIN0 (true) is not gated into CLCx Gate 2
bit 0	LCxG3D1N: Gate 2 Data 1 Negated (inverted) bit 1 = CLCIN0 (inverted) is gated into CLCx Gate 2 0 = CLCIN0 (inverted) is not gated into CLCx Gate 2

PIC16(L)F18856/76

REGISTER 22-10: CLCxGLS3: GATE 3 LOGIC SELECT REGISTER

R/W-x/u	R/W-x/u	R/W-x/u	R/W-x/u	R/W-x/u	R/W-x/u	R/W-x/u	R/W-x/u
LCxG4D4T	LCxG4D4N	LCxG4D3T	LCxG4D3N	LCxG4D2T	LCxG4D2N	LCxG4D1T	LCxG4D1N
bit 7							bit 0

Legend:

R = Readable bit	W = Writable bit	U = Unimplemented bit, read as '0'
u = Bit is unchanged	x = Bit is unknown	-n/n = Value at POR and BOR/Value at all other Resets
'1' = Bit is set	'0' = Bit is cleared	

- bit 7 **LCxG4D4T:** Gate 3 Data 4 True (non-inverted) bit
 1 = CLCIN3 (true) is gated into CLCx Gate 3
 0 = CLCIN3 (true) is not gated into CLCx Gate 3
- bit 6 **LCxG4D4N:** Gate 3 Data 4 Negated (inverted) bit
 1 = CLCIN3 (inverted) is gated into CLCx Gate 3
 0 = CLCIN3 (inverted) is not gated into CLCx Gate 3
- bit 5 **LCxG4D3T:** Gate 3 Data 3 True (non-inverted) bit
 1 = CLCIN2 (true) is gated into CLCx Gate 3
 0 = CLCIN2 (true) is not gated into CLCx Gate 3
- bit 4 **LCxG4D3N:** Gate 3 Data 3 Negated (inverted) bit
 1 = CLCIN2 (inverted) is gated into CLCx Gate 3
 0 = CLCIN2 (inverted) is not gated into CLCx Gate 3
- bit 3 **LCxG4D2T:** Gate 3 Data 2 True (non-inverted) bit
 1 = CLCIN1 (true) is gated into CLCx Gate 3
 0 = CLCIN1 (true) is not gated into CLCx Gate 3
- bit 2 **LCxG4D2N:** Gate 3 Data 2 Negated (inverted) bit
 1 = CLCIN1 (inverted) is gated into CLCx Gate 3
 0 = CLCIN1 (inverted) is not gated into CLCx Gate 3
- bit 1 **LCxG4D1T:** Gate 4 Data 1 True (non-inverted) bit
 1 = CLCIN0 (true) is gated into CLCx Gate 3
 0 = CLCIN0 (true) is not gated into CLCx Gate 3
- bit 0 **LCxG4D1N:** Gate 3 Data 1 Negated (inverted) bit
 1 = CLCIN0 (inverted) is gated into CLCx Gate 3
 0 = CLCIN0 (inverted) is not gated into CLCx Gate 3

PIC16(L)F18856/76

REGISTER 22-11: CLCDATA: CLC DATA OUTPUT

U-0	U-0	U-0	U-0	R-0	R-0	R-0	R-0
—	—	—	—	MLC4OUT	MLC3OUT	MLC2OUT	MLC1OUT
bit 7				bit 0			

Legend:

R = Readable bit

W = Writable bit

U = Unimplemented bit, read as '0'

u = Bit is unchanged

x = Bit is unknown

-n/n = Value at POR and BOR/Value at all other Resets

'1' = Bit is set

'0' = Bit is cleared

bit 7-4 **Unimplemented:** Read as '0'
bit 3 **MLC4OUT:** Mirror copy of LC4OUT bit
bit 2 **MLC3OUT:** Mirror copy of LC3OUT bit
bit 1 **MLC2OUT:** Mirror copy of LC2OUT bit
bit 0 **MLC1OUT:** Mirror copy of LC1OUT bit

PIC16(L)F18856/76

TABLE 22-4: SUMMARY OF REGISTERS ASSOCIATED WITH CLCx

Name	Bit 7	Bit 6	Bit 5	Bit 4	Bit 3	Bit 2	Bit 1	Bit 0	Register on Page
INTCON	GIE	PEIE	—	—	—	—	—	INTEDG	134
PIR5	CLC4IF	CLC3IF	CLC2IF	CLC1IF	—	TMR5GIF	TMR3GIF	TMR1GIF	149
PIE5	CLC4IE	CLC4IE	CLC2IE	CLC1IE	—	TMR5GIE	TMR3GIE	TMR1GIE	140
CLC1CON	LC1EN	—	LC1OUT	LC1INTP	LC1INTN	LC1MODE<2:0>			327
CLC1POL	LC1POL	—	—	—	LC1G4POL	LC1G3POL	LC1G2POL	LC1G1POL	328
CLC1SEL0	—	—	LC1D1S<5:0>						329
CLC1SEL1	—	—	LC1D2S<5:0>						329
CLC1SEL2	—	—	LC1D3S<5:0>						329
CLC1SEL3	—	—	LC1D4S<5:0>						329
CLC1GLS0	LC1G1D4T	LC1G1D4N	LC1G1D3T	LC1G1D3N	LC1G1D2T	LC1G1D2N	LC1G1D1T	LC1G1D1N	330
CLC1GLS1	LC1G2D4T	LC1G2D4N	LC1G2D3T	LC1G2D3N	LC1G2D2T	LC1G2D2N	LC1G2D1T	LC1G2D1N	331
CLC1GLS2	LC1G3D4T	LC1G3D4N	LC1G3D3T	LC1G3D3N	LC1G3D2T	LC1G3D2N	LC1G3D1T	LC1G3D1N	332
CLC1GLS3	LC1G4D4T	LC1G4D4N	LC1G4D3T	LC1G4D3N	LC1G4D2T	LC1G4D2N	LC1G4D1T	LC1G4D1N	333
CLC2CON	LC2EN	—	LC2OUT	LC2INTP	LC2INTN	LC2MODE<2:0>			327
CLC2POL	LC2POL	—	—	—	LC2G4POL	LC2G3POL	LC2G2POL	LC2G1POL	328
CLC2SEL0	—	—	LC2D1S<5:0>						329
CLC2SEL1	—	—	LC2D2S<5:0>						329
CLC2SEL2	—	—	LC2D3S<5:0>						329
CLC2SEL3	—	—	LC2D4S<5:0>						329
CLC2GLS0	LC2G1D4T	LC2G1D4N	LC2G1D3T	LC2G1D3N	LC2G1D2T	LC2G1D2N	LC2G1D1T	LC2G1D1N	330
CLC2GLS1	LC2G2D4T	LC2G2D4N	LC2G2D3T	LC2G2D3N	LC2G2D2T	LC2G2D2N	LC2G2D1T	LC2G2D1N	331
CLC2GLS2	LC2G3D4T	LC2G3D4N	LC2G3D3T	LC2G3D3N	LC2G3D2T	LC2G3D2N	LC2G3D1T	LC2G3D1N	332
CLC2GLS3	LC2G4D4T	LC2G4D4N	LC2G4D3T	LC2G4D3N	LC2G4D2T	LC2G4D2N	LC2G4D1T	LC2G4D1N	333
CLC3CON	LC3EN	—	LC3OUT	LC3INTP	LC3INTN	LC3MODE<2:0>			327
CLC3POL	LC3POL	—	—	—	LC3G4POL	LC3G3POL	LC3G2POL	LC3G1POL	328
CLC3SEL0	—	—	LC3D1S<5:0>						329
CLC3SEL1	—	—	LC3D2S<5:0>						329
CLC3SEL2	—	—	LC3D3S<5:0>						329
CLC3SEL3	—	—	LC3D4S<5:0>						329
CLC3GLS0	LC3G1D4T	LC3G1D4N	LC3G1D3T	LC3G1D3N	LC3G1D2T	LC3G1D2N	LC3G1D1T	LC3G1D1N	330
CLC3GLS1	LC3G2D4T	LC3G2D4N	LC3G2D3T	LC3G2D3N	LC3G2D2T	LC3G2D2N	LC3G2D1T	LC3G2D1N	331
CLC3GLS2	LC3G3D4T	LC3G3D4N	LC3G3D3T	LC3G3D3N	LC3G3D2T	LC3G3D2N	LC3G3D1T	LC3G3D1N	332
CLC3GLS3	LC3G4D4T	LC3G4D4N	LC3G4D3T	LC3G4D3N	LC3G4D2T	LC3G4D2N	LC3G4D1T	LC3G4D1N	333
CLC4CON	LC4EN	—	LC4OUT	LC4INTP	LC4INTN	LC4MODE<2:0>			327
CLC4POL	LC4POL	—	—	—	LC4G4POL	LC4G3POL	LC4G2POL	LC4G1POL	328
CLC4SEL0	—	—	LC4D1S<5:0>						329
CLC4SEL1	—	—	LC4D2S<5:0>						329
CLC4SEL2	—	—	LC4D3S<5:0>						329
CLC4SEL3	—	—	LC4D4S<5:0>						329
CLC4GLS0	LC4G1D4T	LC4G1D4N	LC4G1D3T	LC4G1D3N	LC4G1D2T	LC4G1D2N	LC4G1D1T	LC4G1D1N	330

Legend: — = unimplemented, read as '0'. Shaded cells are unused by the CLCx modules.

PIC16(L)F18856/76

TABLE 22-4: SUMMARY OF REGISTERS ASSOCIATED WITH CLCx (continued)

Name	Bit 7	Bit 6	Bit 5	Bit 4	Bit 3	Bit 2	Bit 1	Bit 0	Register on Page
CLC4GLS1	LC4G2D4T	LC4G2D4N	LC4G2D3T	LC4G2D3N	LC4G2D2T	LC4G2D2N	LC4G2D1T	LC4G2D1N	331
CLC4GLS2	LC4G3D4T	LC4G3D4N	LC4G3D3T	LC4G3D3N	LC4G3D2T	LC4G3D2N	LC4G3D1T	LC4G3D1N	332
CLC4GLS3	LC4G4D4T	LC4G4D4N	LC4G4D3T	LC4G4D3N	LC4G4D2T	LC4G4D2N	LC4G4D1T	LC4G4D1N	333
CLCDATA	—	—	—	—	MLC4OUT	MLC3OUT	MLC2OUT	MLC1OUT	334
CLCIN0PPS	—	—	—	CLCIN0PPS<4:0>					249
CLCIN1PPS	—	—	—	CLCIN1PPS<4:0>					249
CLCIN2PPS	—	—	—	CLCIN2PPS<4:0>					249
CLCIN3PPS	—	—	—	CLCIN3PPS<4:0>					249

Legend: — = unimplemented, read as '0'. Shaded cells are unused by the CLCx modules.

PIC16(L)F18856/76

23.0 ANALOG-TO-DIGITAL CONVERTER WITH COMPUTATION (ADC²) MODULE

The Analog-to-Digital Converter with Computation (ADC²) allows conversion of an analog input signal to a 10-bit binary representation of that signal. This device uses analog inputs, which are multiplexed into a single sample and hold circuit. The output of the sample and hold is connected to the input of the converter. The converter generates a 10-bit binary result via successive approximation and stores the conversion result into the ADC result registers (ADRESH:ADRESL register pair).

Additionally, the following features are provided within the ADC module:

- 8-bit Acquisition Timer
- Hardware Capacitive Voltage Divider (CVD) support:
 - 8-bit Precharge Timer
 - Adjustable sample and hold capacitor array
 - Guard ring digital output drive
- Automatic repeat and sequencing:
 - Automated double sample conversion for CVD
 - Two sets of result registers (Result and Previous result)
 - Auto-conversion trigger
 - Internal retrigger
- Computation features:
 - Averaging and Low-Pass Filter functions
 - Reference Comparison
 - 2-level Threshold Comparison
 - Selectable Interrupts

Figure 23-1 shows the block diagram of the ADC.

The ADC voltage reference is software selectable to be either internally generated or externally supplied.

The ADC can generate an interrupt upon completion of a conversion and upon threshold comparison. These interrupts can be used to wake-up the device from Sleep.

PIC16(L)F18856/76

FIGURE 23-1: ADC² BLOCK DIAGRAM

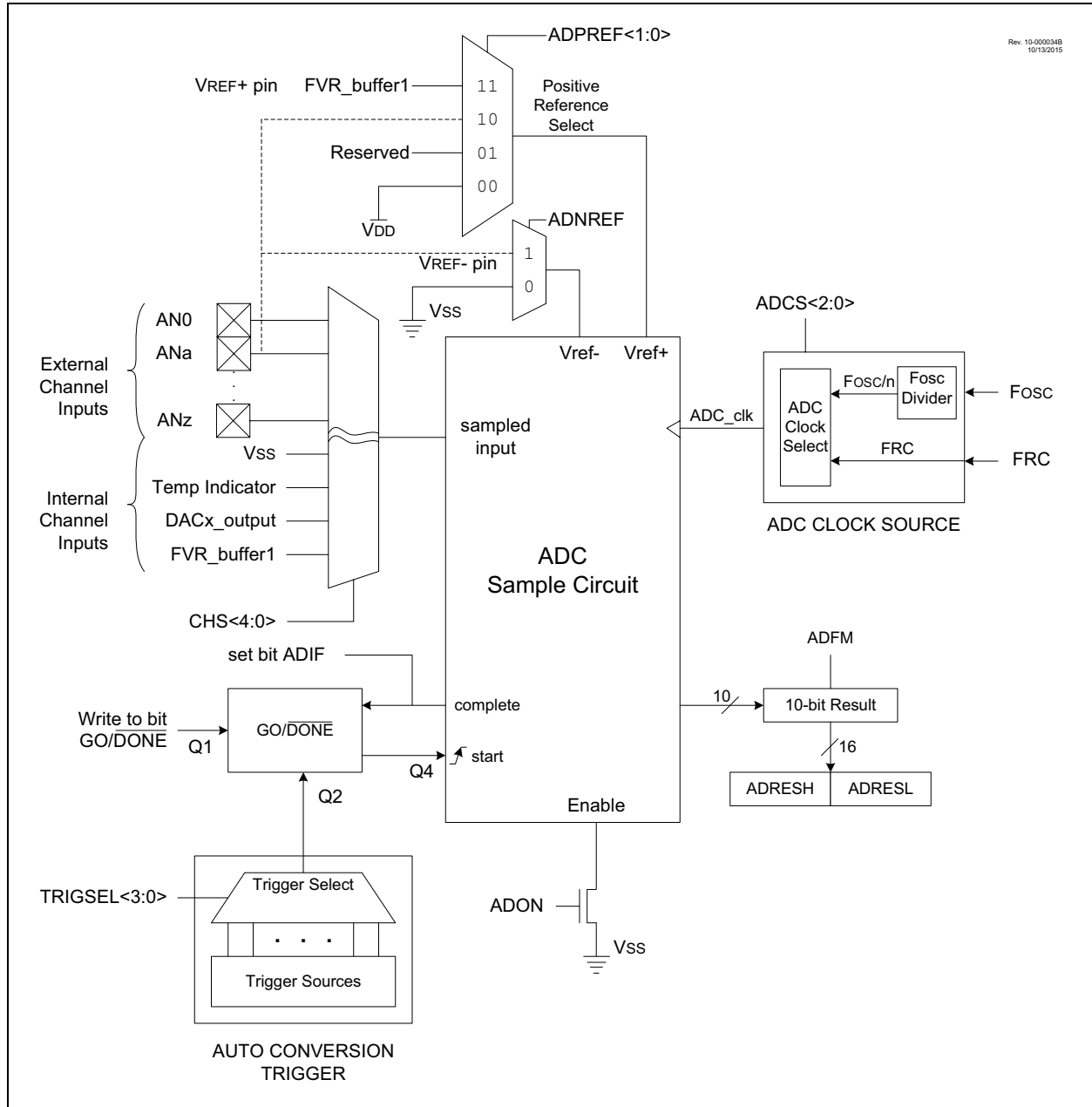

PIC16(L)F18856/76

23.1 ADC Configuration

When configuring and using the ADC the following functions must be considered:

- Port configuration
- Channel selection
- ADC voltage reference selection
- ADC conversion clock source
- Interrupt control
- Result formatting
- Conversion Trigger Selection
- ADC Acquisition Time
- ADC Precharge Time
- Additional Sample and Hold Capacitor
- Single/Double Sample Conversion
- Guard Ring Outputs

23.1.1 PORT CONFIGURATION

The ADC can be used to convert both analog and digital signals. When converting analog signals, the I/O pin should be configured for analog by setting the associated TRIS and ANSEL bits. Refer to [Section 12.0 “I/O Ports”](#) for more information.

Note: Analog voltages on any pin that is defined as a digital input may cause the input buffer to conduct excess current.

23.1.2 CHANNEL SELECTION

There are several channel selections available:

- Eight PORTA pins (RA<7:0>)
- Eight PORTB pins (RB<7:0>)
- Eight PORTC pins (RC<7:0>)
- Eight PORTD pins (RD<7:0>, PIC16(L)F18875 only)
- Three PORTE pins (RE<2:0>, PIC16(L)F18875 only)
- Temperature Indicator
- DAC output
- Fixed Voltage Reference (FVR)
- AVss (ground)

The ADPCH register determines which channel is connected to the sample and hold circuit.

When changing channels, a delay is required before starting the next conversion. Refer to [Section 23.2 “ADC Operation”](#) for more information.

Note: It is recommended that when switching from an ADC channel of a higher voltage to a channel of a lower voltage, the software selects the Vss channel before switching to the channel of the lower voltage. If the ADC does not have a dedicated Vss input channel, the Vss selection (DAC1R<4:0> = b'00000') through the DAC output channel can be used. If the DAC is in use, a free input channel can be connected to Vss, and can be used in place of the DAC.

23.1.3 ADC VOLTAGE REFERENCE

The ADPREF bits of the ADREF register provides control of the positive voltage reference. The positive voltage reference can be:

- VREF+ pin
- VDD
- FVR 1.024V
- FVR 2.048V
- FVR 4.096V

The ADNREF bit of the ADREF register provides control of the negative voltage reference. The negative voltage reference can be:

- VREF- pin
- VSS

See [Section 16.0 “Fixed Voltage Reference \(FVR\)”](#) for more details on the Fixed Voltage Reference.

23.1.4 CONVERSION CLOCK

The source of the conversion clock is software selectable via the ADCLK register and the ADCS bit of the ADCON0 register. There are two possible clock sources:

- $F_{osc}/(2^{*(n+1)})$ (where n is from 0 to 63),
- FRC (dedicated RC oscillator)

The time to complete one bit conversion is defined as TAD. One full 10-bit conversion requires 11.5 TAD periods as shown in [Figure 23-2](#).

For correct conversion, the appropriate TAD specification must be met. Refer to [Table 37-13](#) for more information. [Table 23-1](#) gives examples of appropriate ADC clock selections.

Note 1: Unless using the FRC, any changes in the system clock frequency will change the ADC clock frequency, which may adversely affect the ADC result.

2: The internal control logic of the ADC runs off of the clock selected by the ADCS bit of ADCON0. What this can mean is when the ADCS bit of ADCON0 is set to 1 (ADC runs on FRC), there may be unexpected delays in operation when setting ADC control bits.

PIC16(L)F18856/76

TABLE 23-1: ADC CLOCK PERIOD (TAD) Vs. DEVICE OPERATING FREQUENCIES

ADC Clock Period (TAD)		Device Frequency (Fosc)					
ADC Clock Source	ADCCS<5:0>	32 MHz	20 MHz	16 MHz	8 MHz	4 MHz	1 MHz
Fosc/2	000000	62.5ns ⁽²⁾	100 ns ⁽²⁾	125 ns ⁽²⁾	250 ns ⁽²⁾	500 ns ⁽²⁾	2.0 μs
Fosc/4	000001	125 ns ⁽²⁾	200 ns ⁽²⁾	250 ns ⁽²⁾	500 ns ⁽²⁾	1.0 μs	4.0 μs
Fosc/6	000010	187.5 ns ⁽²⁾	300 ns ⁽²⁾	375 ns ⁽²⁾	750 ns ⁽²⁾	1.5 μs	6.0 μs
Fosc/8	000011	250 μs ⁽²⁾	400 ns ⁽²⁾	500 μs ⁽²⁾	1.0 μs	2.0 μs	8.0 μs ⁽³⁾
...
Fosc/16	000111	500 ns ⁽²⁾	800 ns ⁽²⁾	1.0 μs	2.0 μs	4.0 μs	16.0 μs ⁽²⁾
...
Fosc/128	111111	4.0 μs	6.4 μs	8.0 μs	16.0 μs ⁽³⁾	32.0 μs ⁽²⁾	128.0 μs ⁽²⁾
FRC	ADCS(ADCON0<4>)=1	1.0-6.0 μs ⁽¹⁾	1.0-6.0 μs ⁽¹⁾	1.0-6.0 μs ⁽¹⁾	1.0-6.0 μs ⁽¹⁾	1.0-6.0 μs ⁽¹⁾	1.0-6.0 μs ⁽¹⁾

Legend: Shaded cells are outside of recommended range.

Note 1: See TAD parameter for FRC source typical TAD value.

2: These values violate the required TAD time.

3: Outside the recommended TAD time.

4: The ADC clock period (TAD) and total ADC conversion time can be minimized when the ADC clock is derived from the system clock FOSC. However, the FRC oscillator source must be used when conversions are to be performed with the device in Sleep mode.

FIGURE 23-2: ANALOG-TO-DIGITAL CONVERSION TAD CYCLES (ADSC = 0)

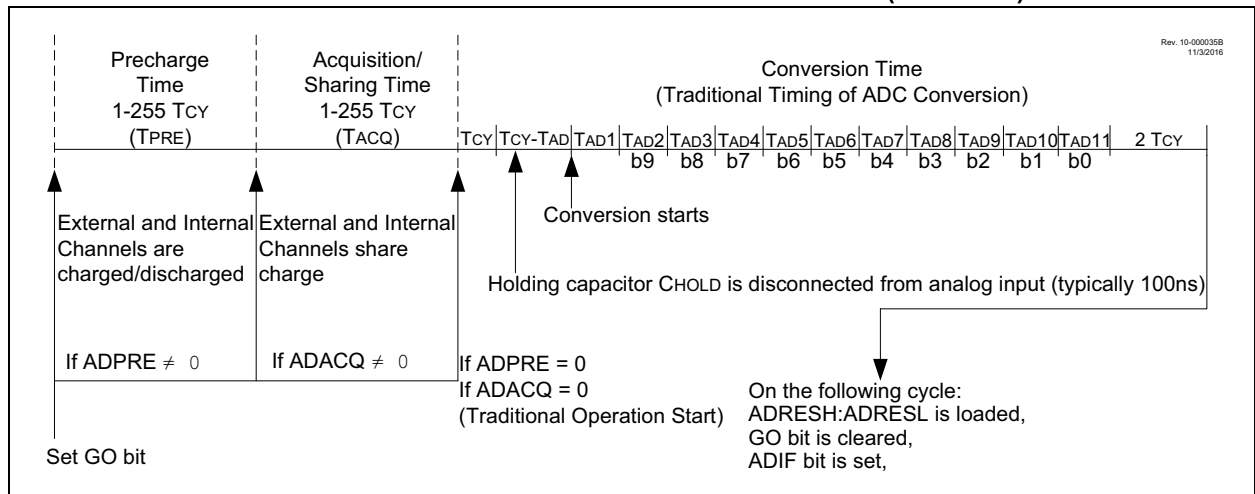

PIC16(L)F18856/76

23.1.5 INTERRUPTS

The ADC module allows for the ability to generate an interrupt upon completion of an Analog-to-Digital conversion. The ADC Interrupt Flag is the ADIF bit in the PIR1 register. The ADC Interrupt Enable is the ADIE bit in the PIE1 register. The ADIF bit must be cleared in software.

- Note 1:** The ADIF bit is set at the completion of every conversion, regardless of whether or not the ADC interrupt is enabled.
- 2:** The ADC operates during Sleep only when the FRC oscillator is selected.

This interrupt can be generated while the device is operating or while in Sleep. If the device is in Sleep, the interrupt will wake-up the device. Upon waking from Sleep, the next instruction following the SLEEP instruction is always executed. If the user is attempting to wake-up from Sleep and resume in-line code execution, the ADIE bit of the PIE1 register and the PEIE bit of the INTCON register must both be set and the GIE bit of the INTCON register must be cleared. If all three of these bits are set, the execution will switch to the Interrupt Service Routine.

23.1.6 RESULT FORMATTING

The 10-bit ADC conversion result can be supplied in two formats, left justified or right justified. The ADFRM0 bit of the ADCON0 register controls the output format.

Figure 23-3 shows the two output formats.

Software writes to the ADRES register pair are always right justified regardless of the selected format mode. Therefore, data read after writing to ADRES when ADFRM0 = 0 will be shifted left six places. For example, writing 0xFF to ADRESL will be read as 0xC0 in ADRESL and 0x3F logical OR'd with whatever was in the two MSbits in ADRESH.

FIGURE 23-3: 10-BIT ADC CONVERSION RESULT FORMAT

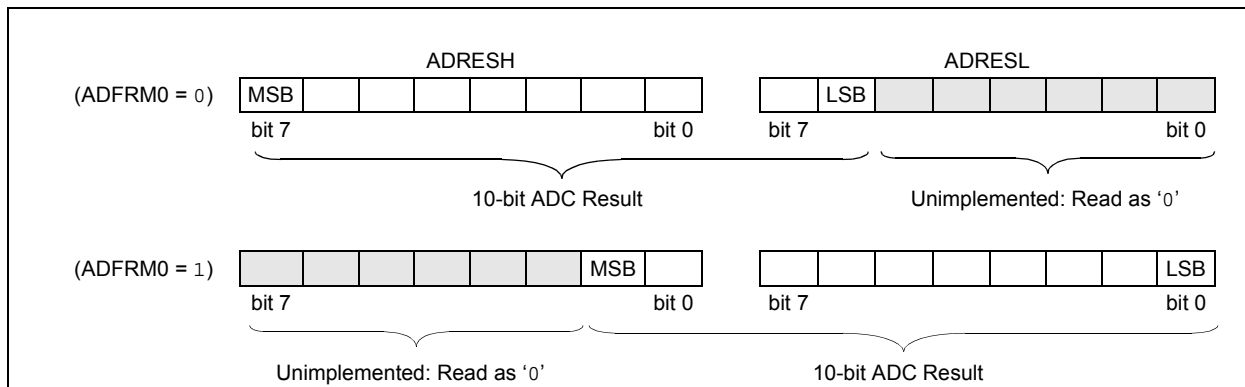

PIC16(L)F18856/76

23.2 ADC Operation

23.2.1 STARTING A CONVERSION

To enable the ADC module, the ADON bit of the ADCON0 register must be set to a '1'. A conversion may be started by any of the following:

- Software setting the ADGO bit of ADCON0 to '1'
- An external trigger (selected by [Register 23-3](#))
- A continuous-mode retrigger (see section [Section 23.5.8 “Continuous Sampling Mode”](#))

Note: The ADGO bit should not be set in the same instruction that turns on the ADC. Refer to [Section 23.2.7 “ADC Conversion Procedure \(Basic Mode\)”](#).

23.2.2 COMPLETION OF A CONVERSION

When any individual conversion is complete, the value already in ADRES is written into ADPREV (if ADPSIS=1) and the new conversion results appear in ADRES. When the conversion completes, the ADC module will:

- Clear the ADGO bit (Unless the ADCONT bit of ADCON0 is set)
- Set the ADIF Interrupt Flag bit
- Set the ADMATH bit
- Update ADACC

When ADDSEN=0 then after every conversion, or when ADDSEN=1 then after every other conversion, the following events occur:

- ADERR is calculated
- ADTIF is set if ADERR calculation meets threshold requirements

In addition, on the completion of every conversion if ADDSEN=0, or every other conversion if ADDSEN=1:

- ADSTPE is calculated
- Depending on ADSTPE, the threshold comparison may set ADTIF

Importantly, filter and threshold computations occur after the conversion itself is complete. As such, interrupt handlers responding to ADIF should check ADTIF before reading filter and threshold results.

23.2.3 TERMINATING A CONVERSION

If a conversion must be terminated before completion, the ADGO bit can be cleared in software. The ADRESH and ADRESL registers will be updated with the partially complete Analog-to-Digital conversion sample. Incomplete bits will match the last bit converted. In this case, filter and/or threshold occur.

Note: A device Reset forces all registers to their Reset state. Thus, the ADC module is turned off and any pending conversion is terminated.

PIC16(L)F18856/76

23.2.4 ADC OPERATION DURING SLEEP

The ADC module can operate during Sleep. This requires the ADC clock source to be set to the FRC option. When the FRC oscillator source is selected, the ADC waits one additional instruction before starting the conversion. This allows the `SLEEP` instruction to be executed, which can reduce system noise during the conversion. If the ADC interrupt is enabled, the device will wake-up from Sleep when the conversion completes. If the ADC interrupt is disabled, the ADC module is turned off after the conversion completes, although the `ADON` bit remains set.

23.2.5 EXTERNAL TRIGGER DURING SLEEP

If the external trigger is received during sleep while ADC clock source is set to the FRC, then the ADC module will perform the conversion and set the `ADIF` bit upon completion.

If an external trigger is received when the ADC clock source is something other than FRC, then the trigger will be recorded, but the conversion will not begin until the device exits Sleep.

23.2.6 AUTO-CONVERSION TRIGGER

The Auto-conversion Trigger allows periodic ADC measurements without software intervention. When a rising edge of the selected source occurs, the `ADGO` bit is set by hardware.

The Auto-conversion Trigger source is selected with the `ADACT<4:0>` bits of the `ADACT` register.

PIC16(L)F18856/76

Using the Auto-conversion Trigger does not assure proper ADC timing. It is the user's responsibility to ensure that the ADC timing requirements are met. See [Table 23-2](#) for auto-conversion sources.

TABLE 23-2: ADC AUTO-CONVERSION TABLE

ADACT Value	Source Peripheral	Description
0x00	Disabled	External Trigger Disabled
0x01	ADACTPPS	Pin selected by ADACTPPS
0x02	TMR0	Timer0 overflow condition
0x03	TMR1	Timer1 overflow condition
0x04	TMR2	Match between Timer2 postscaled value and PR2
0x05	TMR3	Timer3 overflow condition
0x06	TMR4	Match between Timer4 postscaled value and PR4
0x07	TMR5	Timer5 overflow condition
0x08	TMR6	Match between Timer6 postscaled value and PR6
0x09	SMT1	Match between SMT1 and SMT1PR
0x0A	SMT2	Match between SMT2 and SMT2PR
0x0B	CCP1	CCP1 output
0x0C	CCP2	CCP2 output
0x0D	CCP3	CCP3 output
0x0E	CCP4	CCP4 output
0x0F	CCP5	CCP5 output
0x10	PWM6	PWM6 output
0x11	PWM7	PWM7 output
0x12	C1	Comparator C1 output
0x13	C2	Comparator C2 output
0x14	IOC	Interrupt-on-change interrupt trigger
0x15	CLC1	CLC1 output
0x16	CLC2	CLC2 output
0x17	CLC3	CLC3 output
0x18	CLC4	CLC4 output
0x19-0x1B	Reserved	Reserved, do not use
0x1C	ADERR	Read of ADERR register
0x1D	ADRESH	Read of ADRESH register
0x1E	Reserved	Reserved, do not use
0x1F	ADPCH	Read of ADPCH register

PIC16(L)F18856/76

23.2.7 ADC CONVERSION PROCEDURE (BASIC MODE)

This is an example procedure for using the ADC to perform an Analog-to-Digital conversion:

1. Configure Port:
 - Disable pin output driver (Refer to the TRISx register)
 - Configure pin as analog (Refer to the ANSELx register)
2. Configure the ADC module:
 - Select ADC conversion clock
 - Configure voltage reference
 - Select ADC input channel (precharge+acquisition)
 - Turn on ADC module
3. Configure ADC interrupt (optional):
 - Clear ADC interrupt flag
 - Enable ADC interrupt
 - Enable peripheral interrupt (PEIE bit)
 - Enable global interrupt (GIE bit)⁽¹⁾
4. If ADACQ=0, software must wait the required acquisition time ⁽²⁾.
5. Start conversion by setting the ADGO bit.
6. Wait for ADC conversion to complete by one of the following:
 - Polling the ADGO bit
 - Waiting for the ADC interrupt (interrupts enabled)
7. Read ADC Result.
8. Clear the ADC interrupt flag (required if interrupt is enabled).

Note 1: The global interrupt can be disabled if the user is attempting to wake-up from Sleep and resume in-line code execution.

2: Refer to [Section 23.3 “ADC Acquisition Requirements”](#).

EXAMPLE 23-1: ADC CONVERSION

```
;This code block configures the ADC
;for polling, VDD and VSS references, FRC
;oscillator and AN0 input.
;
;Conversion start & polling for completion
;are included.
;
BANKSEL    ADCON1    ;
MOVLW     B'11110000' ;Right justify,
FRC
;oscillator
MOVWF     ADCON1    ;Vdd and Vss Vref
BANKSEL    TRISA    ;
BSF       TRISA,0  ;Set RA0 to input
BANKSEL    ANSEL    ;
BSF       ANSEL,0  ;Set RA0 to analog
BANKSEL    ADCON0   ;
MOVLW     B'00000001' ;Select channel AN0
MOVWF     ADCON0   ;Turn ADC On
CALL      SampleTime ;Acquisition delay
BSF       ADCON0,ADGO ;Start conversion
BTFSC     ADCON0,ADGO ;Is conversion done?
GOTO      $-1      ;No, test again
BANKSEL    ADRESH   ;
MOVF      ADRESH,W ;Read upper 2 bits
MOVWF     RESULTHI  ;store in GPR space
BANKSEL    ADRESL   ;
MOVF      ADRESL,W  ;Read lower 8 bits
```

PIC16(L)F18856/76

23.3 ADC Acquisition Requirements

For the ADC to meet its specified accuracy, the charge holding capacitor (CHOLD) must be allowed to fully charge to the input channel voltage level. The Analog Input model is shown in Figure 23-4. The source impedance (RS) and the internal sampling switch (RSS) impedance directly affect the time required to charge the capacitor CHOLD. The sampling switch (RSS) impedance varies over the device voltage (VDD), refer to Figure 23-4. **The maximum recommended impedance for analog sources is 10 kΩ.** As the

source impedance is decreased, the acquisition time may be decreased. After the analog input channel is selected (or changed), an ADC acquisition must be completed before the conversion can be started. To calculate the minimum acquisition time, Equation 23-1 may be used. This equation assumes that 1/2 LSB error is used (1,024 steps for the ADC). The 1/2 LSB error is the maximum error allowed for the ADC to meet its specified resolution.

EQUATION 23-1: ACQUISITION TIME EXAMPLE

Assumptions: Temperature = 50°C and external impedance of 10kΩ 5.0V VDD

$$\begin{aligned}T_{ACQ} &= \text{Amplifier Settling Time} + \text{Hold Capacitor Charging Time} + \text{Temperature Coefficient} \\ &= T_{AMP} + T_C + T_{COFF} \\ &= 2\mu s + T_C + [(Temperature - 25^\circ C)(0.05\mu s/^\circ C)]\end{aligned}$$

The value for TC can be approximated with the following equations:

$$V_{APPLIED} \left(1 - \frac{1}{(2^{n+1}) - 1} \right) = V_{CHOLD} \quad ;[1] \text{ } V_{CHOLD} \text{ charged to within } 1/2 \text{ lsb}$$

$$V_{APPLIED} \left(1 - e^{-\frac{T_C}{RC}} \right) = V_{CHOLD} \quad ;[2] \text{ } V_{CHOLD} \text{ charge response to } V_{APPLIED}$$

$$V_{APPLIED} \left(1 - e^{-\frac{T_C}{RC}} \right) = V_{APPLIED} \left(1 - \frac{1}{(2^{n+1}) - 1} \right) \quad ;\text{combining [1] and [2]}$$

Note: Where n = number of bits of the ADC.

Solving for TC:

$$\begin{aligned}T_C &= -CHOLD(RIC + RSS + RS) \ln(1/2047) \\ &= -10pF(1k\Omega + 7k\Omega + 10k\Omega) \ln(0.0004885) \\ &= 1.37\mu s\end{aligned}$$

Therefore:

$$\begin{aligned}T_{ACQ} &= 2\mu s + 892ns + [(50^\circ C - 25^\circ C)(0.05\mu s/^\circ C)] \\ &= 4.62\mu s\end{aligned}$$

Note 1: The reference voltage (VREF) has no effect on the equation, since it cancels itself out.

2: The charge holding capacitor (CHOLD) is not discharged after each conversion.

3: The maximum recommended impedance for analog sources is 10 kΩ. This is required to meet the pin leakage specification.

PIC16(L)F18856/76

FIGURE 23-4: ANALOG INPUT MODEL

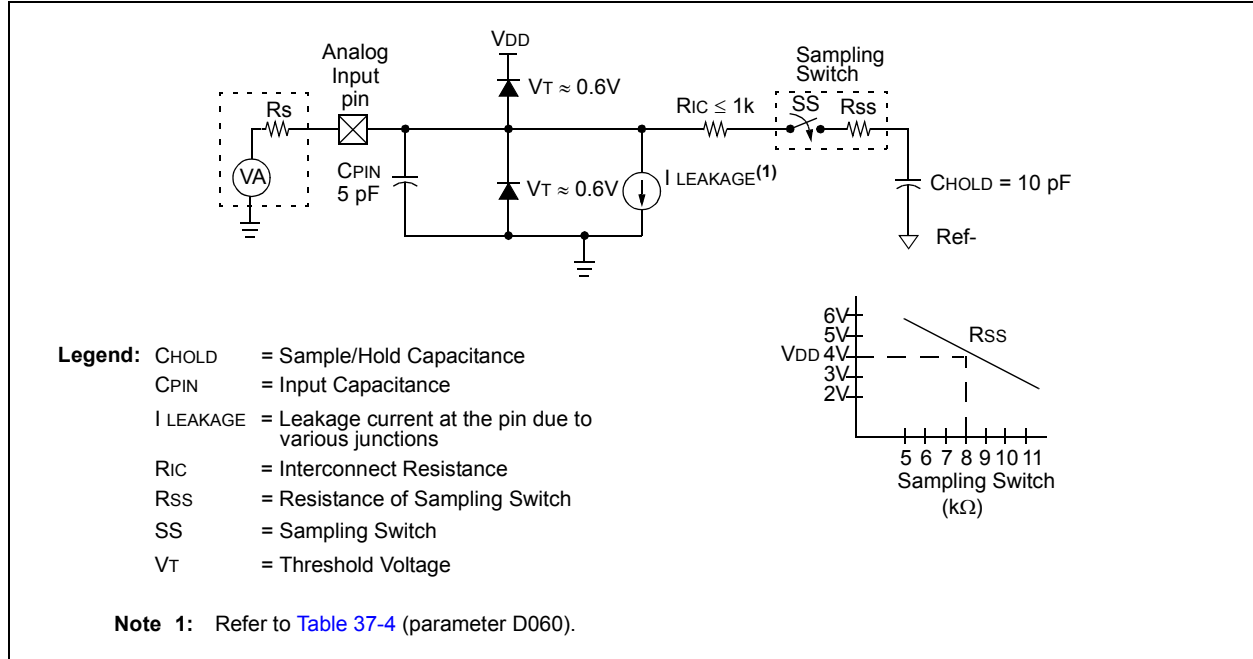
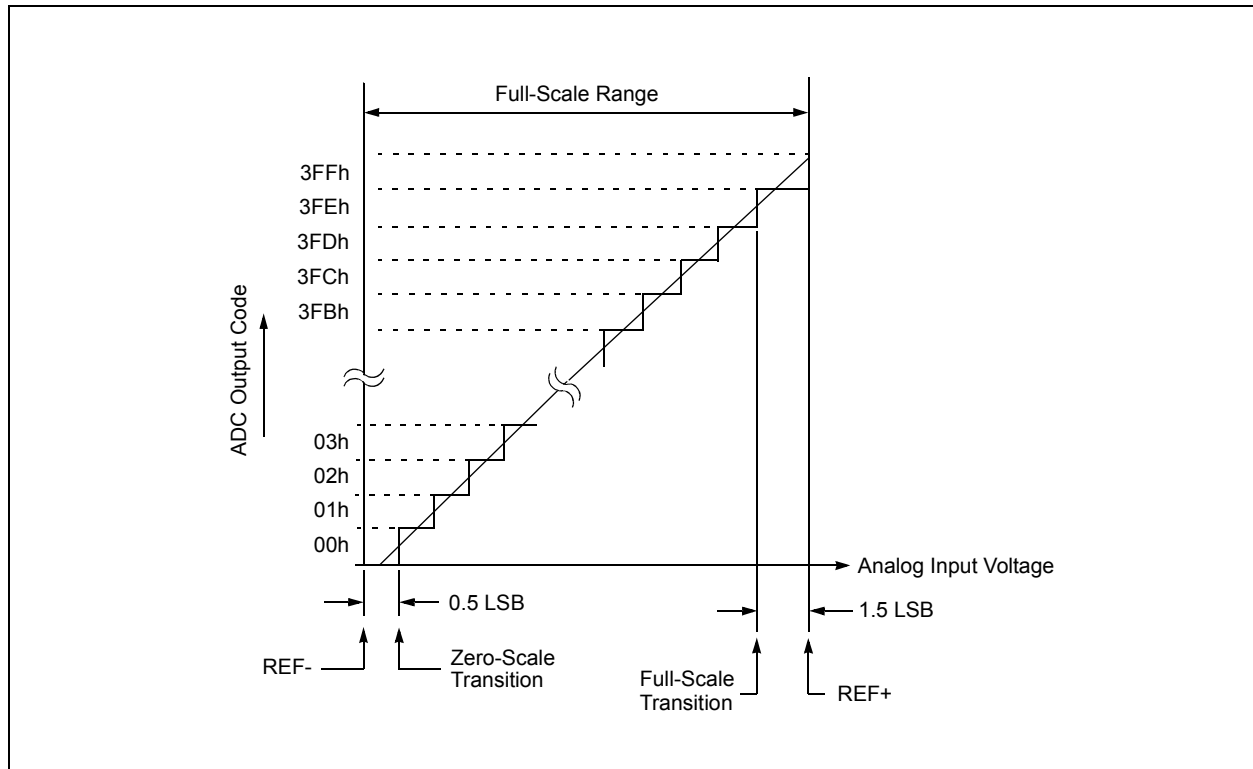

FIGURE 23-5: ADC TRANSFER FUNCTION



PIC16(L)F18856/76

23.4 Capacitive Voltage Divider (CVD) Features

The ADC module contains several features that allow the user to perform a relative capacitance measurement on any ADC channel using the internal ADC sample and hold capacitance as a reference. This relative capacitance measurement can be used to implement capacitive touch or proximity sensing applications. [Figure 23-6](#) shows the basic block diagram of the CVD portion of the ADC module.

FIGURE 23-6: HARDWARE CAPACITIVE VOLTAGE DIVIDER BLOCK DIAGRAM

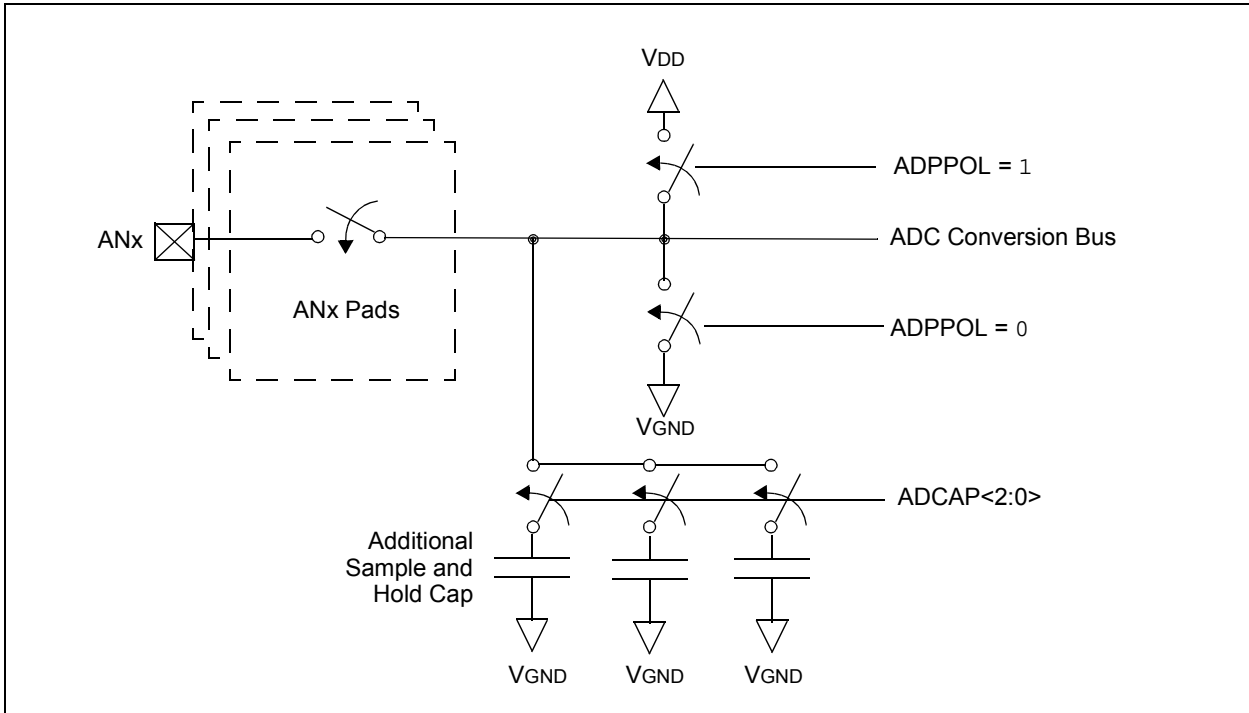

PIC16(L)F18856/76

23.4.1 CVD OPERATION

A CVD operation begins with the ADC's internal sample and hold capacitor (C_{HOLD}) being disconnected from the path which connects it to the external capacitive sensor node. While disconnected, C_{HOLD} is precharged to V_{DD} or V_{SS} , while the path to the sensor node is also discharged to V_{DD} or V_{SS} . Typically, this node is discharged to the level opposite that of C_{HOLD} . When the precharge phase is complete, the $V_{\text{DD}}/V_{\text{SS}}$ bias paths for the two nodes are shut off and C_{HOLD} and the path to the external sensor node are reconnected, at which time the acquisition phase of the CVD operation begins. During acquisition, a capacitive voltage divider is formed between the precharged C_{HOLD} and sensor nodes, which results in a final voltage level setting on C_{HOLD} , which is determined by the capacitances and precharge levels of the two nodes. After acquisition, the ADC converts the voltage level on C_{HOLD} . This process is then repeated with the selected precharge levels for both the C_{HOLD} and the inverted sensor nodes. Figure 23-7 shows the waveform for two inverted CVD measurements, which is known as differential CVD measurement.

FIGURE 23-7: DIFFERENTIAL CVD MEASUREMENT WAVEFORM

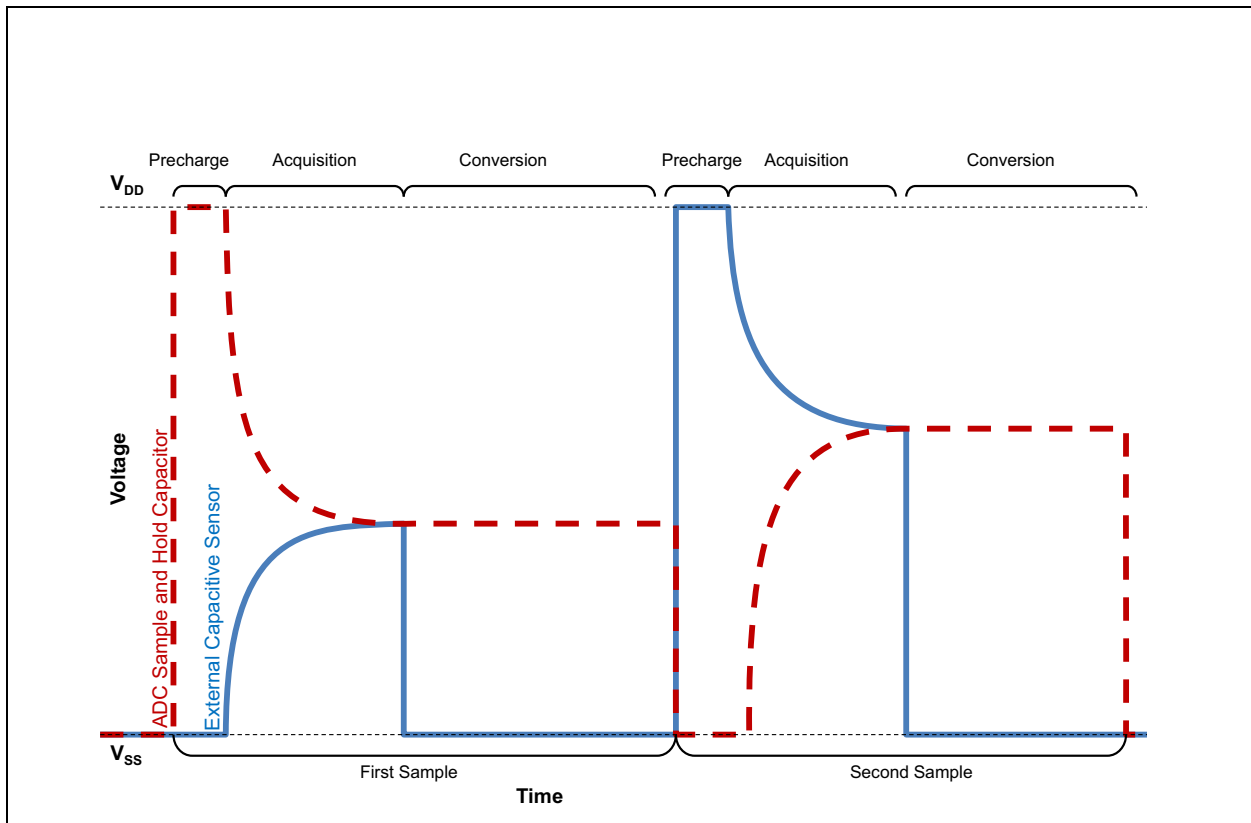

PIC16(L)F18856/76

23.4.2 PRECHARGE CONTROL

The precharge stage is an optional period of time that brings the external channel and internal sample and hold capacitor to known voltage levels. Precharge is enabled by writing a non-zero value to the ADPRE register. This stage is initiated when an ADC conversion begins, either from setting the ADGO bit, a special event trigger, or a conversion restart from the computation functionality. If the ADPRE register is cleared when an ADC conversion begins, this stage is skipped.

During the precharge time, CHOLD is disconnected from the outer portion of the sample path that leads to the external capacitive sensor and is connected to either VDD or VSS, depending on the value of the ADPPOL bit of ADCON1. At the same time, the port pin logic of the selected analog channel is overridden to drive a digital high or low out, in order to precharge the outer portion of the ADC's sample path, which includes the external sensor. The output polarity of this override is also determined by the ADPPOL bit of ADCON1. The amount of time that this charging needs is controlled by the ADPRE register.

Note: The external charging overrides the TRIS setting of the respective I/O pin. If there is a device attached to this pin, precharge should not be used.

23.4.3 ACQUISITION CONTROL

The Acquisition stage is an optional time for the voltage on the internal sample and hold capacitor to charge or discharge from the selected analog channel. This acquisition time is controlled by the ADACQ register. When ADPRE=0, acquisition starts at the beginning of conversion. When ADPRE=1, the acquisition stage begins when precharge ends.

At the start of the acquisition stage, the port pin logic of the selected analog channel is overridden to turn off the digital high/low output drivers so they do not affect the final result of the charge averaging. Also, the selected ADC channel is connected to CHOLD. This allows charge averaging to proceed between the precharged channel and the CHOLD capacitor.

Note: When ADPRE!=0, acquisition time cannot be '0'. In this case, setting ADACQ to '0' will set a maximum acquisition time (256 ADC clock cycles). When precharge is disabled, setting ADACQ to '0' will disable hardware acquisition time control.

23.4.4 GUARD RING OUTPUTS

The purpose of the guard ring is to generate a signal in phase with the CVD sensing signal to minimize the effects of the parasitic capacitance on sensing electrodes. It also can be used as a mutual drive for mutual capacitive sensing. For more information about active guard and mutual drive, see Application Note AN1478, "mTouch™ Sensing Solution Acquisition Methods Capacitive Voltage Divider" (DS01478).

Figure 23-8 shows a typical guard ring circuit. CGUARD represents the capacitance of the guard ring trace placed on the PCB board. The user selects values for RA and RB that will create a voltage profile on CGUARD, which will match the selected acquisition channel.

The ADC has two guard ring drive outputs, ADGRDA and ADGRDB. These outputs can be routed through PPS controls to I/O pins (see Section 13.0 "Peripheral Pin Select (PPS) Module" for details). The polarity of these outputs are controlled by the ADGPOL and ADIPEN bits of ADCON1.

At the start of the first precharge stage, both outputs are set to match the ADGPOL bit of ADCON1. Once the acquisition stage begins, ADGRDA changes polarity, while ADGRDB remains unchanged. When performing a double sample conversion, setting the ADIPEN bit of ADCON1 causes both guard ring outputs to transition to the opposite polarity of ADGPOL at the start of the second precharge stage, and ADGRDA toggles again for the second acquisition. For more information on the timing of the guard ring output, refer to Figure 23-8 and Figure 23-9.

FIGURE 23-8: GUARD RING CIRCUIT

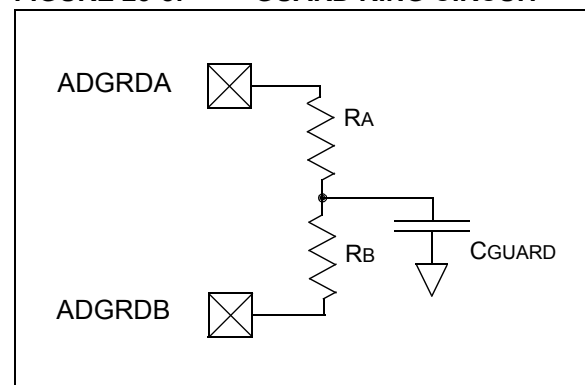

PIC16(L)F18856/76

FIGURE 23-9: DIFFERENTIAL CVD WITH GUARD RING OUTPUT WAVEFORM

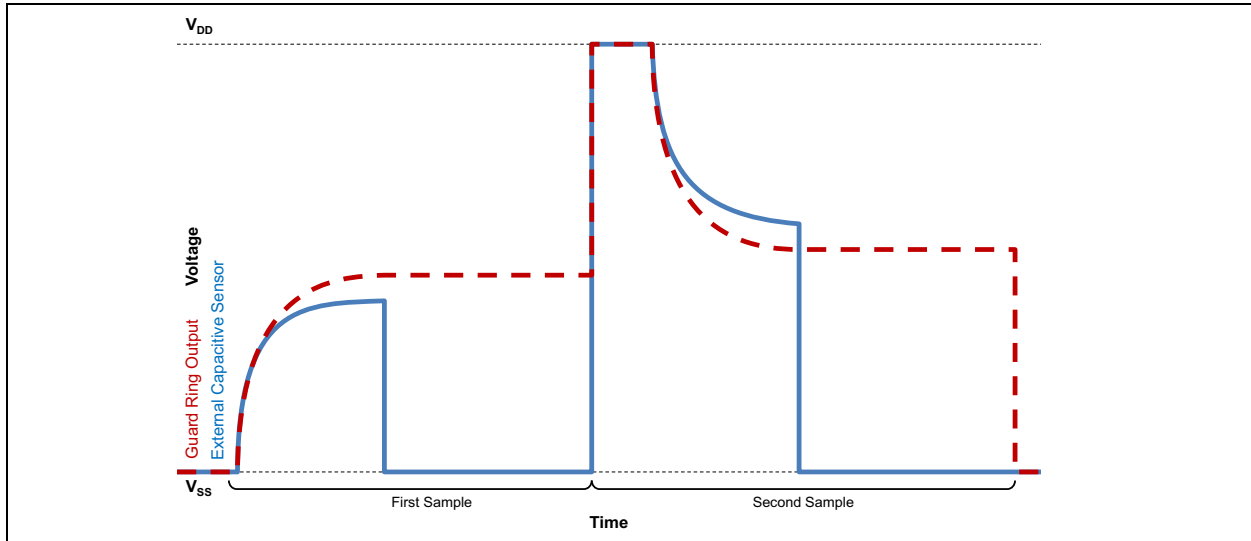

PIC16(L)F18856/76

23.4.5 ADDITIONAL SAMPLE AND HOLD CAPACITANCE

Additional capacitance can be added in parallel with the internal sample and hold capacitor (CHOLD) by means of the ADCAP register. This register selects a digitally programmable capacitance which is added to the ADC conversion bus, increasing the effective internal capacitance of the sample and hold capacitor in the ADC module. This is used to improve the match between internal and external capacitance for a better sensing performance. The additional capacitance does not affect analog performance of the ADC because it is not connected during conversion. See [Figure 23-10](#).

23.5 Computation Operation

The ADC module hardware is equipped with post conversion computation features. These features provide data post-processing functions that can be operated on the ADC conversion result, including digital filtering/averaging and threshold comparison functions.

FIGURE 23-10: COMPUTATIONAL FEATURES SIMPLIFIED BLOCK DIAGRAM

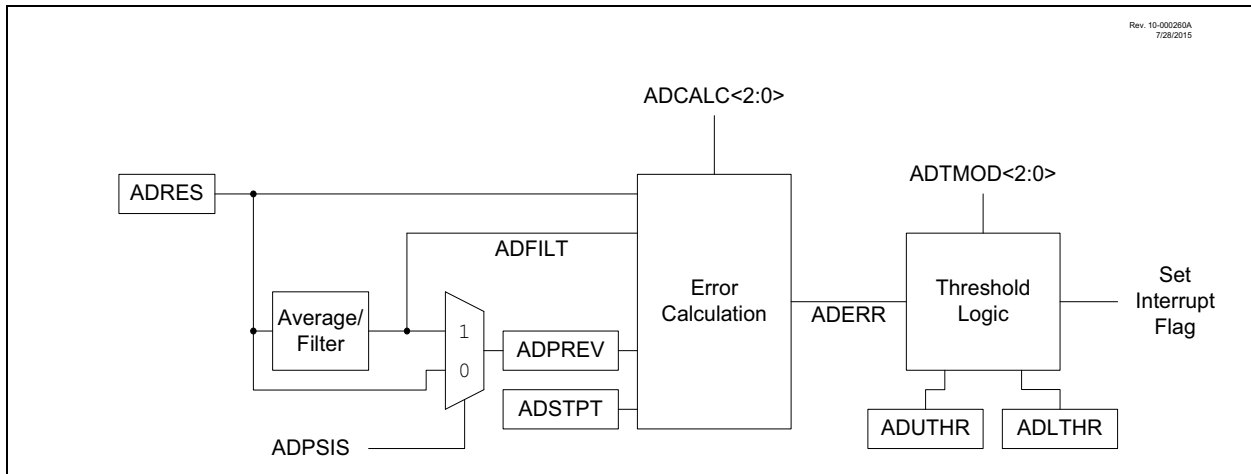

The operation of the ADC computational features is controlled by the ADMD <2:0> bits in the ADCON2 register.

The module can be operated in one of five modes:

- **Basic:** This is a legacy mode. In this mode, ADC conversion occurs on single (ADDSSEN=0) or double (ADDSSEN=1) samples. ADIF is set after each conversion completes.
- **Accumulate:** With each trigger, the ADC conversion result is added to accumulator and ADCNT increments. ADIF is set after each conversion. ADTIF is set according to the Calculation mode.
- **Average:** With each trigger, the ADC conversion result is added to the accumulator. When the ADRPT number of samples have been accumulated, a threshold test is performed. Upon the next trigger, the counter is reset to '1' and the accumulator is replaced with the first ADC conversion cleared. For the subsequent threshold tests, additional ADRPT samples are required to be accumulated.
- **Burst Average:** At the trigger, the accumulator and counter are cleared. The ADC conversion results are then collected repetitively until ADRPT samples are accumulated and finally the threshold is tested.

- **Low-Pass Filter (LPF):** With each trigger, the ADC conversion result is sent through a filter. When ADRPT samples have occurred, a threshold test is performed. Every trigger after that the ADC conversion result is sent through the filter and another threshold test is performed.

The five modes are summarized in [Table 23-3](#) below.

TABLE 23-3: COMPUTATION MODES

Mode	ADMD	Clear Conditions	Value after Trigger completion		Threshold Operations			VA
		ADACC and ADCNT	ADACC	ADCNT	Retrigger	Threshold Test	Interrupt	ADAOV
Basic	0	ADACL _R = 1	Unchanged	Unchanged	No	Every Sample	If threshold=true	N/A
Accumulate	1	ADACL _R = 1	S + ADACC or (S2-S1) + ADACC	If (ADCNT=FF): ADCNT, otherwise: ADCNT+1	No	Every Sample	If threshold=true	ADACC Over
Average	2	ADACL _R = 1 or ADCNT >= ADRPT at ADGO or retrigger	S + ADACC or (S2-S1) + ADACC	If (ADCNT >= ADRPT): 1, otherwise: ADCNT+1	No	If ADCNT >= ADRPT	If threshold=true	ADACC Over
Burst Average	3	ADACL _R = 1 or ADGO set or retrigger	Each repetition: same as Average End with sum of all samples	Reset and count up until ADCNT=ADRPT	Repeat while ADCNT < ADRPT	If ADCNT >= ADRPT	If threshold=true	ADACC Over
Lowpass Filter	4	ADACL _R = 1	$S + ADACC - ADACC / 2^{ADCRS}$ or $(S2-S1) + ADACC - ADACC / 2^{ADCRS}$	If (ADCNT=FF): ADCNT, otherwise: ADCNT+1	No	If ADCNT >= ADRPT	If threshold=true	ADACC Over

Note 1: S, S1, and S2 are abbreviations for ADRES, ADRES(n), and ADRES(n+1), respectively. When ADDSEN = 0: S = ADRES. When ADDSEN = 1: S1 = ADPREV, and S2 = ADRES.

2: All results of divisions using the ADCRS bits are truncated, not rounded.

PIC16(L)F18856/76

23.5.1 DIGITAL FILTER/AVERAGE

The digital filter/average module consists of an accumulator with data feedback options, and control logic to determine when threshold tests need to be applied. The accumulator is a 16-bit wide signed register (15 bits + 1 sign bit), which can be accessed through the ADACCH:ADACCL register pair.

Upon each trigger event (the ADGO bit set or external event trigger), the ADC conversion result is added to the accumulator. If the value exceeds '1111111111111111', then the overflow bit ADAOV in the ADSTAT register is set.

The number of samples to be accumulated is determined by the ADRPT (A/D Repeat Setting) register. Each time a sample is added to the accumulator, the ADCNT register is incremented. In Average and Burst Average modes the ADCNT and ADACC registers are cleared automatically when a trigger causes the ADCNT value to exceed the ADRPT value to '1' and replace the ADACC contents with the conversion result.

The ADAOV (accumulator overflow) bit in the ADSTAT register, ADACC, and ADCNT registers will be cleared any time the ADACLR bit in the ADCON2 register is set.

Note: When ADC is operating from FRC, 5 FRC clock cycles are required to execute the ADACC clearing operation.

The ADCRS <2:0> bits in the ADCON2 register control the data shift on the accumulator result, which effectively divides the value in the accumulator (ADACCH:ADACCL) register pair. For the Accumulate mode of the digital filter, the shift provides a simple scaling operation. For the Average/Burst Average mode, the shift bits are used to determine number of samples for averaging. For the Lowpass Filter mode, the shift is an integral part of the filter, and determines the cut-off frequency of the filter. Table 23-4 shows the -3 dB cut-off frequency in ωT (radians) and the highest signal attenuation obtained by this filter at nyquist frequency ($\omega T = \pi$).

TABLE 23-4: LOWPASS FILTER -3 dB CUT-OFF FREQUENCY

ADCRS	ωT (radians) @ -3 dB Frequency	dB @ $F_{nyquist}=1/(2T)$
1	0.72	-9.5
2	0.284	-16.9
3	0.134	-23.5
4	0.065	-29.8
5	0.032	-36.0

23.5.2 BASIC MODE

Basic mode (ADMD = 000) disables all additional computation features. In this mode, no accumulation occurs. Double sampling, Continuous mode, all CVD features, and threshold error detection are still available, but no features involving the digital filter/average features are used.

23.5.3 ACCUMULATE MODE:

In Accumulate mode (ADMD = 001), the ADC conversion result is added to the ADACC registers. The Formatting mode does not affect the right-justification of the ADACC value. Upon each sample, ADCNT is incremented, indicating the number of samples accumulated. After each sample and accumulation, the ADFLTR register is updated with the value of ADACC right shifted by the ADCRS value, a threshold comparison is performed (see Section 23.5.7 "Threshold Comparison") and the ADTIF interrupt may trigger.

23.5.4 AVERAGE MODE

In Average Mode (ADMD = 010), the ADACC registers accumulate with each ADC sample, much as in Accumulate mode, and the ADCNT register increments with each sample. However, in Average mode, the threshold comparison is performed upon ADCNT being greater than or equal to a user-defined ADRPT value. The ADCRS bits still right-shift the final result, but in this mode when $ADCRS = \log(ADRPT)/\log(2)$ then the final accumulated value will be divided by number of samples, allowing for a threshold comparison operation on the average of all gathered samples.

PIC16(L)F18856/76

23.5.5 BURST AVERAGE MODE

The Burst Average mode (ADMD = '011') acts the same as the Average mode in most respects. The one way it differs is that it continuously retriggers ADC sampling until the ADCNT value is greater than or equal to ADRPT, even if Continuous Sampling mode (see [Section 23.5.8 "Continuous Sampling Mode"](#)) is not enabled. This allows for a threshold comparison on the average of a short burst of ADC samples.

23.5.6 LOWPASS FILTER MODE

The Lowpass Filter mode (ADMD = '100') acts similarly to the Average mode in how it handles samples (accumulates samples until ADCNT value greater than or equal to ADRPT, then triggers threshold comparison), but instead of a simple average, it performs a lowpass filter operation on all of the samples, reducing the effect of high-frequency noise on the average, then performs a threshold comparison on the results. (see [Table 23-3](#) for a more detailed description of the mathematical operation). In this mode, the ADCRS bits determine the cut-off frequency of the lowpass filter (as demonstrated by [Table 23-4](#)).

23.5.7 THRESHOLD COMPARISON

At the end of each computation:

- The conversion results are latched and held stable at the end-of-conversion.
- The difference value is calculated based on a difference calculation which is selected by the ADCALC<2:0> bits in the ADCON3 register. The value can be one of the following calculations (see [Register 23-4](#) for more details):
 - The first derivative of single measurements
 - The CVD result in CVD mode
 - The current result vs. a setpoint
 - The current result vs. the filtered/average result
 - The first derivative of the filtered/average value
 - Filtered/average value vs. a setpoint
- The result of the calculation (ADERR) is compared to the upper and lower thresholds, ADUTH<ADUTHH:ADUTHL> and ADLTH<ADLTHH:ADLTHL> registers, to set the ADUTHR and ADLTHR flag bits. The threshold logic is selected by ADTMD<2:0> bits in the ADCON3 register. The threshold trigger option can be one of the following
 - Never interrupt
 - Error is less than lower threshold
 - Error is greater than or equal to lower threshold
 - Error is between thresholds (inclusive)
 - Error is outside of thresholds
 - Error is less than or equal to upper threshold
 - Error is greater than upper threshold
 - Always interrupt regardless of threshold test results
- The threshold interrupt flag ADTIF is set when the threshold condition is met.

Note 1: The threshold tests are signed operations.

2: If ADAOV is set, a threshold interrupt is signaled.

23.5.8 CONTINUOUS SAMPLING MODE

Setting the ADCONT bit in the ADCON0 register automatically retriggers a new conversion cycle after updating the ADACC register. That means the ADGO bit is set to generate automatic retriggering, until the device Reset occurs or the A/D Stop-on-interrupt bit (ADSOI in the ADCON3 register) is set (correct logic).

23.5.9 DOUBLE SAMPLE CONVERSION

Double sampling is enabled by setting the ADDSEN bit of the ADCON1 register. When this bit is set, two conversions are required before the module will calculate threshold error (each conversion must still be triggered separately). The first conversion will set the ADMATH bit of the ADSTAT register and update ADACC, but will not calculate ADERR or trigger ADTIF. When the second conversion completes, the first value is transferred to ADPREV (depending on the setting of ADPSIS) and the value of the second conversion is placed into ADRES. Only upon the completion of the second conversion is ADERR calculated and ADTIF triggered (depending on the value of ADCALC).

PIC16(L)F18856/76

23.6 Register Definitions: ADC Control

REGISTER 23-1: ADCON0: ADC CONTROL REGISTER 0

R/W-0/0	R/W-0/0	U-0	R/W-0/0	U-0	R/W-0/0	U-0	R/W/HC-0
ADON	ADCONT	—	ADCS	—	ADFRM0	—	ADGO
bit 7							bit 0

Legend:

R = Readable bit

W = Writable bit

U = Unimplemented bit, read as '0'

u = Bit is unchanged

x = Bit is unknown

-n/n = Value at POR and BOR/Value at all other Resets

'1' = Bit is set

'0' = Bit is cleared

HC = Bit is cleared by hardware

- bit 7 **ADON:** ADC Enable bit
1 = ADC is enabled
0 = ADC is disabled
- bit 6 **ADCONT:** ADC Continuous Operation Enable bit
1 = ADGO is retrIGGERED upon completion of each conversion trigger until ADTIF is set (if ADSOI is set) or until ADGO is cleared (regardless of the value of ADSOI)
0 = ADGO is cleared upon completion of each conversion trigger
- bit 5 **Unimplemented:** Read as '0'
- bit 4 **ADCS:** ADC Clock Selection bit
1 = Clock supplied from FRC dedicated oscillator
0 = Clock supplied by FOSC, divided according to ADCLK register
- bit 3 **Unimplemented:** Read as '0'
- bit 2 **ADFRM0:** ADC results Format/alignment Selection
1 = ADRES and ADPREV data are right-justified
0 = ADRES and ADPREV data are left-justified, zero-filled
- bit 1 **Unimplemented:** Read as '0'
- bit 0 **ADGO:** ADC Conversion Status bit
1 = ADC conversion cycle in progress. Setting this bit starts an ADC conversion cycle. The bit is cleared by hardware as determined by the ADCONT bit
0 = ADC conversion completed/not in progress

PIC16(L)F18856/76

REGISTER 23-2: ADCON1: ADC CONTROL REGISTER 1

R/W-0/0	R/W-0/0	R/W-0/0	U-0	U-0	U-0	U-0	R/W-0/0
ADPPOL	ADIPEN	ADGPOL	—	—	—	—	ADDSSEN
bit 7							bit 0

Legend:

R = Readable bit	W = Writable bit	U = Unimplemented bit, read as '0'
u = Bit is unchanged	x = Bit is unknown	-n/n = Value at POR and BOR/Value at all other Resets
'1' = Bit is set	'0' = Bit is cleared	

bit 7 **ADPPOL:** Precharge Polarity bit
If $ADPRE > 0x00$:

ADPPOL	Action During 1st Precharge Stage	
	External (selected analog I/O pin)	Internal (AD sampling capacitor)
1	Shorted to AVDD	C_{HOLD} shorted to VSS
0	Shorted to VSS	C_{HOLD} shorted to AVDD

Otherwise

The bit is ignored

bit 6 **ADIPEN:** A/D Inverted Precharge Enable bit

If $ADDSSEN = 1$:

1 = The precharge and guard signals in the second conversion cycle are the opposite polarity of the first cycle

0 = Both Conversion cycles use the precharge and guards specified by ADPPOL and ADGPOL

Otherwise:

The bit is ignored

bit 5 **ADGPOL:** Guard Ring Polarity Selection bit

1 = ADC guard ring outputs start as digital high during precharge stage

0 = ADC guard ring outputs start as digital low during precharge stage

bit 4-1 **Unimplemented:** Read as '0'

bit 0 **ADDSSEN:** Double-Sample Enable bit

1 = See [Table 23-5](#).

0 = One conversion is performed for each trigger

TABLE 23-5: EXAMPLE OF REGISTER VALUES FOR ACCUMULATE AND AVERAGE MODES

Trigger ADCONT		Sample n	ADRES	ADPREV ADPSIS		ADACC
0	1			0	1	
T1	T1	1	S(n)	S(n-1)	ADFLTR(n-1)	ADACC(n-1)-S(n-1)
T2	—	2	S(n)	S(n-1)	ADFLTR(n-2)	ADACC(n-1)+S(n-1)
T3	T2	3	S(n)	S(n-1)	ADFLTR(n-1)	ADACC(n-1)-S(n-1)
T4	—	4	S(n)	S(n-1)	ADFLTR(n-2)	ADACC(n-1)+S(n-1)
T5	T3	5	S(n)	S(n-1)	ADFLTR(n-1)	ADACC(n-1)-S(n-1)
T6	—	6	S(n)	S(n-1)	ADFLTR(n-2)	ADACC(n-1)+S(n-1)

PIC16(L)F18856/76

REGISTER 23-3: ADCON2: ADC CONTROL REGISTER 2

R/W-0/0	R/W-0/0	R/W-0/0	R/W-0/0	R/W/HC-0	R/W-0/0	R/W-0/0	R/W-0/0
ADPSIS	ADCRS<2:0>			ADACL	ADMD<2:0>		
bit 7				bit 0			

Legend:

R = Readable bit	W = Writable bit	U = Unimplemented bit, read as '0'
u = Bit is unchanged	x = Bit is unknown	-n/n = Value at POR and BOR/Value at all other Resets
'1' = Bit is set	'0' = Bit is cleared	HC = Bit is cleared by hardware

- bit 7 **ADPSIS:** ADC Previous Sample Input Select bits
 1 = ADFLTR is transferred to ADPREV at start-of-conversion
 0 = ADRES is transferred to ADPREV at start-of-conversion
- bit 6-4 **ADCRS<2:0>:** ADC Accumulated Calculation Right Shift Select bits
 111 = Reserved
 110 = Reserved
 101 through 000:
 If ADMD = 100:
 Low-pass filter time constant is 2^{ADCRS} , filter gain is 1:1
 If ADMD = 001, 010 or 011:
 The accumulated value is right-shifted by ADCRS (divided by 2^{ADCRS})⁽²⁾
 Otherwise:
 Bits are ignored
- bit 3 **ADACL:** ADC Accumulator Clear Command bit
 1 = Initial clear of ADACC, ADAOV, and the sample counter. Bit is cleared by hardware.
 0 = Clearing action is complete (or not started)
- bit 2-0 **ADMD<2:0>:** ADC Operating Mode Selection bits⁽¹⁾
 111 = Reserved
 .
 .
 .
 101 = Reserved
 100 = Low-pass Filter mode
 011 = Burst Average mode
 010 = Average mode
 001 = Accumulate mode
 000 = Basic (Legacy) mode

Note 1: See [Table 23-3](#) for Full mode descriptions.

2: All results of divisions using the ADCRS bits are truncated, not rounded.

PIC16(L)F18856/76

REGISTER 23-4: ADCON3: ADC THRESHOLD REGISTER

U-0	R/W-0/0	R/W-0/0	R/W-0/0	R/W/HC-0	R/W-0/0	R/W-0/0	R/W-0/0
—	ADCALC<2:0>			ADSOI	ADTMD<2:0>		
bit 7				bit 0			

Legend:

R = Readable bit	W = Writable bit	U = Unimplemented bit, read as '0'
u = Bit is unchanged	x = Bit is unknown	-n/n = Value at POR and BOR/Value at all other Resets
'1' = Bit is set	'0' = Bit is cleared	HC = Bit is cleared by hardware

bit 7 **Unimplemented:** Read as '0'

bit 6-4 **ADCALC<2:0>:** ADC Error Calculation Mode Select bits

ADCALC	Action During 1st Precharge Stage		Application
	ADDSSEN = 0 Single-Sample Mode	ADDSSEN = 1 CVD Double-Sample Mode ⁽¹⁾	
111	Reserved	Reserved	Reserved
110	Reserved	Reserved	Reserved
101	ADFLTR-ADSTPT	ADFLTR-ADSTPT	Average/filtered value vs. setpoint
100	ADPREV-ADFLTR	ADPREV-ADFLTR	First derivative of filtered value ⁽³⁾ (negative)
011	Reserved	Reserved	Reserved
010	ADRES-ADFLTR	(ADRES-ADPREV)-ADFLTR	Actual result vs. averaged/filtered value
001	ADRES-ADSTPT	(ADRES-ADPREV)-ADSTPT	Actual result vs. setpoint
000	ADRES-ADPREV	ADRES-ADPREV	First derivative of single measurement ⁽²⁾
			Actual CVD result in CVD mode ⁽²⁾

bit 3 **ADSOI:** ADC Stop-on-Interrupt bit

If ADCONT = 1:

1 = ADGO is cleared when the threshold conditions are met, otherwise the conversion is retrIGGERED

0 = ADGO is not cleared by hardware, must be cleared by software to stop retriggers

If ADCONT = 0 bit is ignored.

bit 2-0 **ADTMD<2:0>:** Threshold Interrupt Mode Select bits

111 = Always set ADTIF at end of calculation

110 = Set ADTIF if ADERR > ADUTH

101 = Set ADTIF if ADERR ≤ ADUTH

100 = Set ADTIF if ADERR < ADLTH or ADERR > ADUTH

011 = Set ADTIF if ADERR > ADLTH and ADERR < ADUTH

010 = Set ADTIF if ADERR ≥ ADLTH

001 = Set ADTIF if ADERR < ADLTH

000 = ADTIF is disabled

Note 1: When ADPSIS = 0, the value of (ADRES-ADPREV) is the value of (S2-S1) from [Table 23-3](#).

2: When ADPSIS = 0

3: When ADPSIS = 1.

PIC16(L)F18856/76

REGISTER 23-5: ADSTAT: ADC THRESHOLD REGISTER

R-0/0	R-0/0	R-0/0	R/C/HS-0/0	U-0	R-0/0	R-0/0	R-0/0
ADAOV	ADUTHR	ADLTHR	ADMATH	—	ADSTAT<2:0>		
bit 7							bit 0

Legend:

R = Readable bit	W = Writable bit	U = Unimplemented bit, read as '0'
u = Bit is unchanged	x = Bit is unknown	-n/n = Value at POR and BOR/Value at all other Resets
'1' = Bit is set	'0' = Bit is cleared	

bit 7	ADAOV: ADC Computation Overflow bit 1 = ADC accumulator or ADERR calculation have overflowed 0 = ADC accumulator and ADERR calculation have not overflowed
bit 6	ADUTHR: ADC Module Greater-than Upper Threshold Flag bit 1 = ADERR > ADUTH 0 = ADERR ≤ ADUTH
bit 5	ADLTHR: ADC Module Less-than Lower Threshold Flag bit 1 = ADERR < ADLTH 0 = ADERR ≥ ADLTH
bit 4	ADMATH: ADC Module Computation Status bit 1 = Registers ADACC, ADFLTR, ADUTH, ADLTH and the ADAOV bit are updating or have already updated 0 = Associated registers/bits have not changed since this bit was last cleared
bit 3	Unimplemented: Read as '0'
bit 2-0	ADSTAT<0:2>: ADC Module Cycle Multistage Status bits ⁽¹⁾ 111 = ADC module is in 2 nd conversion stage 110 = ADC module is in 2 nd acquisition stage 101 = ADC module is in 2 nd precharge stage 100 = Not used 011 = ADC module is in 1 st conversion stage 010 = ADC module is in 1 st acquisition stage 001 = ADC module is in 1 st precharge stage 000 = ADC module is not converting

Note 1: If ADOSC=1, and FOSC<FRC, these bits may be invalid.

PIC16(L)F18856/76

REGISTER 23-6: ADCLK: ADC CLOCK SELECTION REGISTER

U-0	U-0	R/W-0/0	R/W-0/0	R/W-0/0	R/W-0/0	R/W-0/0	R/W-0/0
—	—	ADCCS<5:0>					
bit 7							bit 0

Legend:

R = Readable bit W = Writable bit U = Unimplemented bit, read as '0'
u = Bit is unchanged x = Bit is unknown -n/n = Value at POR and BOR/Value at all other Resets
'1' = Bit is set '0' = Bit is cleared

bit 7-6 **Unimplemented:** Read as '0'
bit 5-0 **ADCCS<5:0>:** ADC Conversion Clock Select bits
 111111 = Fosc/128
 111110 = Fosc/126
 111101 = Fosc/124
 .
 .
 .
 000000 = Fosc/2

REGISTER 23-7: ADREF: ADC REFERENCE SELECTION REGISTER

U-0	U-0	U-0	R/W-0/0	U-0	U-0	R/W-0/0	R/W-0/0
—	—	—	ADNREF	—	—	ADPREF<1:0>	
bit 7							bit 0

Legend:

R = Readable bit W = Writable bit U = Unimplemented bit, read as '0'
u = Bit is unchanged x = Bit is unknown -n/n = Value at POR and BOR/Value at all other Resets
'1' = Bit is set '0' = Bit is cleared

bit 7-5 **Unimplemented:** Read as '0'
bit 4 **ADNREF:** ADC Negative Voltage Reference Selection bit
 1 = VREF- is connected to VREF- pin
 0 = VREF- is connected to AVSS
bit 3-2 **Unimplemented:** Read as '0'
bit 1-0 **ADPREF:** ADC Positive Voltage Reference Selection bits
 11 = VREF+ is connected to FVR_buffer 1
 10 = VREF+ is connected to VREF+ pin
 01 = Reserved
 00 = VREF+ is connected to VDD

PIC16(L)F18856/76

REGISTER 23-8: ADPCH: ADC POSITIVE CHANNEL SELECTION REGISTER

U-0	U-0	R/W-0/0	R/W-0/0	R/W-0/0	R/W-0/0	R/W-0/0	R/W-0/0	
—	—	ADPCH<5:0>						
bit 7								bit 0

Legend:

R = Readable bit	W = Writable bit	U = Unimplemented bit, read as '0'
u = Bit is unchanged	x = Bit is unknown	-n/n = Value at POR and BOR/Value at all other Resets
'1' = Bit is set	'0' = Bit is cleared	

bit 7-6 **Unimplemented:** Read as '0'

bit 5-0 **ADPCH<5:0>:** ADC Positive Input Channel Selection bits

111111 = Fixed Voltage Reference (FVR)⁽²⁾

111110 = DAC1 output⁽¹⁾

111101 = Temperature Indicator⁽³⁾

111100 = AVss (Analog Ground)

111011 = Reserved. No channel connected.

•

•

•

100010 = ANE2⁽⁴⁾

100001 = ANE1⁽⁴⁾

100000 = ANE0⁽⁴⁾

011111 = AND7⁽⁴⁾

011110 = AND6⁽⁴⁾

011101 = AND5⁽⁴⁾

011100 = AND4⁽⁴⁾

011011 = AND3⁽⁴⁾

011010 = AND2⁽⁴⁾

011001 = AND1⁽⁴⁾

011000 = AND0⁽⁴⁾

010111 = ANC7

010110 = ANC6

010101 = ANC5

010100 = ANC4

010011 = ANC3

010010 = ANC2

010001 = ANC1

010000 = ANC0

001111 = ANB7

001110 = ANB6

001101 = ANB5

001100 = ANB4

001011 = ANB3

001010 = ANB2

001001 = ANB1

001000 = ANB0

000111 = ANA7

000110 = ANA6

000101 = ANA5

000100 = ANA4

000011 = ANA3

000010 = ANA2

000001 = ANA1

000000 = ANA0

Note 1: See [Section 25.0 “5-Bit Digital-to-Analog Converter \(DAC1\) Module”](#) for more information.

Note 2: See [Section 16.0 “Fixed Voltage Reference \(FVR\)”](#) for more information.

Note 3: See [Section 17.0 “Temperature Indicator Module”](#) for more information.

Note 4: PIC16(L)F18875 only.

PIC16(L)F18856/76

REGISTER 23-9: ADPRE: ADC PRECHARGE TIME CONTROL REGISTER

R/W-0/0	R/W-0/0	R/W-0/0	R/W-0/0	R/W-0/0	R/W-0/0	R/W-0/0	R/W-0/0
ADPRE<7:0>							
bit 7							bit 0

Legend:

R = Readable bit	W = Writable bit	U = Unimplemented bit, read as '0'
u = Bit is unchanged	x = Bit is unknown	-n/n = Value at POR and BOR/Value at all other Resets
'1' = Bit is set	'0' = Bit is cleared	

bit 7-0 **ADPRE<7:0>**: Precharge Time Select bits⁽¹⁾
 11111111 = Precharge time is 255 clocks of the selected ADC clock
 11111110 = Precharge time is 254 clocks of the selected ADC clock
 .
 .
 .
 00000001 = Precharge time is 1 clock of the selected ADC clock
 00000000 = Precharge time is not included in the data conversion cycle

Note 1: When FOSC is selected as the ADC clock (ADCS bit of ADCON0 = 0), both ADPRE and ADACQ are calculated using undivided FOSC, regardless of the value of the ADCLK register.

REGISTER 23-10: ADACQ: ADC ACQUISITION TIME CONTROL REGISTER

R/W-0/0	R/W-0/0	R/W-0/0	R/W-0/0	R/W-0/0	R/W-0/0	R/W-0/0	R/W-0/0
ADACQ<7:0>							
bit 7							bit 0

Legend:

R = Readable bit	W = Writable bit	U = Unimplemented bit, read as '0'
u = Bit is unchanged	x = Bit is unknown	-n/n = Value at POR and BOR/Value at all other Resets
'1' = Bit is set	'0' = Bit is cleared	

bit 7-0 **ADACQ<7:0>**: Acquisition (charge share time) Select bits⁽¹⁾
 11111111 = Acquisition time is 255 clocks of the selected ADC clock
 11111110 = Acquisition time is 254 clocks of the selected ADC clock
 .
 .
 .
 00000001 = Acquisition time is 1 clock of the selected ADC clock
 00000000 = Acquisition time is not included in the data conversion cycle⁽²⁾

Note 1: When FOSC is selected as the ADC clock (ADCS bit of ADCON0 = 0), both ADPRE and ADACQ are calculated using undivided FOSC, regardless of the value of the ADCLK register.

2: If ADPRE! = 0, ADAQC = 0 will instead set an Acquisition time of 256 clocks of the selected ADC clock.

PIC16(L)F18856/76

REGISTER 23-11: ADCAP: ADC ADDITIONAL SAMPLE CAPACITOR SELECTION REGISTER

U-0	U-0	U-0	R/W-0/0	R/W-0/0	R/W-0/0	R/W-0/0	R/W-0/0	
—	—	—	ADCAP<4:0>					
bit 7								bit 0

Legend:

R = Readable bit	W = Writable bit	U = Unimplemented bit, read as '0'
u = Bit is unchanged	x = Bit is unknown	-n/n = Value at POR and BOR/Value at all other Resets
'1' = Bit is set	'0' = Bit is cleared	

bit 7-5 **Unimplemented:** Read as '0'

bit 4-0 **ADCAP<4:0>:** ADC Additional Sample Capacitor Selection bits

11111	= 31 pF
11110	= 30 pF
11101	= 29 pF
•	
•	
•	
00011	= 3 pF
00010	= 2 pF
00001	= 1 pF
00000	= No additional capacitance

REGISTER 23-12: ADRPT: ADC REPEAT SETTING REGISTER

R/W-0/0	R/W-0/0	R/W-0/0	R/W-0/0	R/W-0/0	R/W-0/0	R/W-0/0	R/W-0/0	
ADRPT<7:0>								
bit 7								bit 0

Legend:

R = Readable bit	W = Writable bit	U = Unimplemented bit, read as '0'
u = Bit is unchanged	x = Bit is unknown	-n/n = Value at POR and BOR/Value at all other Resets
'1' = Bit is set	'0' = Bit is cleared	

bit 7-0 **ADRPT<7:0>:** ADC Repeat Threshold bits

Counts the number of times that the ADC has been triggered. Used in conjunction along with ADCNT to determine when the error threshold is checked for Low-pass Filter, Burst Average, and Average modes.

PIC16(L)F18856/76

REGISTER 23-13: ADCNT: ADC CONVERSION COUNTER REGISTER

R/W-x/u	R/W-x/u	R/W-x/u	R/W-x/u	R/W-x/u	R/W-x/u	R/W-x/u	R/W-x/u
ADCNT<7:0>							
bit 7							bit 0

Legend:

R = Readable bit	W = Writable bit	U = Unimplemented bit, read as '0'
u = Bit is unchanged	x = Bit is unknown	-n/n = Value at POR and BOR/Value at all other Resets
'1' = Bit is set	'0' = Bit is cleared	

bit 7-0 **ADCNT<7:0>**: ADC Conversion Counter
Counts the number of times that the ADC is triggered. Determines when the threshold is checked for the Low-Pass Filter, Burst Average, and Average Computation modes. Count saturates at 0xFF and does not roll-over to 0x00.

REGISTER 23-14: ADFLTRH: ADC FILTER HIGH BYTE REGISTER

R-x	R-x	R-x	R-x	R-x	R-x	R-x	R-x
ADFLTR<15:8>							
bit 7							bit 0

Legend:

R = Readable bit	W = Writable bit	U = Unimplemented bit, read as '0'
u = Bit is unchanged	x = Bit is unknown	-n/n = Value at POR and BOR/Value at all other Resets
'1' = Bit is set	'0' = Bit is cleared	

bit 7-0 **ADFLTR<15:8>**: ADC Filter Output Most Significant bits and Sign bit
In Accumulate, Average, and Burst Average mode, this is equal to ADACC right shifted by the ADCRS bits of ADCON2. In LPF mode, this is the output of the Lowpass Filter.

REGISTER 23-15: ADFLTRL: ADC FILTER LOW BYTE REGISTER

R-x	R-x	R-x	R-x	R-x	R-x	R-x	R-x
ADFLTR<7:0>							
bit 7							bit 0

Legend:

R = Readable bit	W = Writable bit	U = Unimplemented bit, read as '0'
u = Bit is unchanged	x = Bit is unknown	-n/n = Value at POR and BOR/Value at all other Resets
'1' = Bit is set	'0' = Bit is cleared	

bit 7-0 **ADFLTR<7:0>**: ADC Filter Output Least Significant bits
In Accumulate, Average, and Burst Average mode, this is equal to ADACC right shifted by the ADCRS bits of ADCON2. In LPF mode, this is the output of the Lowpass Filter.

PIC16(L)F18856/76

REGISTER 23-16: ADRESH: ADC RESULT REGISTER HIGH, ADFRM=0

R/W-x/u	R/W-x/u	R/W-x/u	R/W-x/u	R/W-x/u	R/W-x/u	R/W-x/u	R/W-x/u
ADRES<9:2>							
bit 7							bit 0

Legend:

R = Readable bit	W = Writable bit	U = Unimplemented bit, read as '0'
u = Bit is unchanged	x = Bit is unknown	-n/n = Value at POR and BOR/Value at all other Resets
'1' = Bit is set	'0' = Bit is cleared	

bit 7-0 **ADRES<9:2>**: ADC Result Register bits
Most Significant eight bits of 10-bit conversion result.

REGISTER 23-17: ADRESL: ADC RESULT REGISTER LOW, ADFRM=0

R/W-x/u	R/W-x/u	R/W-x/u	R/W-x/u	R/W-x/u	R/W-x/u	R/W-x/u	R/W-x/u
ADRES<1:0>		—	—	—	—	—	—
bit 7							bit 0

Legend:

R = Readable bit	W = Writable bit	U = Unimplemented bit, read as '0'
u = Bit is unchanged	x = Bit is unknown	-n/n = Value at POR and BOR/Value at all other Resets
'1' = Bit is set	'0' = Bit is cleared	

bit 7-6 **ADRES<1:0>**: ADC Result Register bits. Least Significant two bits of 10-bit conversion result.
bit 5-0 **Reserved**: Do not use.

REGISTER 23-18: ADRESH: ADC RESULT REGISTER HIGH, ADFRM=1

R/W-x/u	R/W-x/u	R/W-x/u	R/W-x/u	R/W-x/u	R/W-x/u	R/W-x/u	R/W-x/u
—	—	—	—	—	—	ADRES<9:8>	
bit 7							bit 0

Legend:

R = Readable bit	W = Writable bit	U = Unimplemented bit, read as '0'
u = Bit is unchanged	x = Bit is unknown	-n/n = Value at POR and BOR/Value at all other Resets
'1' = Bit is set	'0' = Bit is cleared	

bit 7-2 **Reserved**: Do not use.
bit 1-0 **ADRES<9:8>**: ADC Sample Result bits. Most Significant two bits of 10-bit conversion result.

PIC16(L)F18856/76

REGISTER 23-19: ADRESL: ADC RESULT REGISTER LOW, ADFRM=1

R/W-x/u	R/W-x/u	R/W-x/u	R/W-x/u	R/W-x/u	R/W-x/u	R/W-x/u	R/W-x/u
ADRES<7:0>							
bit 7							bit 0

Legend:

R = Readable bit	W = Writable bit	U = Unimplemented bit, read as '0'
u = Bit is unchanged	x = Bit is unknown	-n/n = Value at POR and BOR/Value at all other Resets
'1' = Bit is set	'0' = Bit is cleared	

bit 7-0 **ADRES<7:0>**: ADC Result Register bits. Least Significant eight bits of 10-bit conversion result.

REGISTER 23-20: ADPREVH: ADC PREVIOUS RESULT REGISTER

R-x	R-x	R-x	R-x	R-x	R-x	R-x	R-x
ADPREV<15:8>							
bit 7							bit 0

Legend:

R = Readable bit	W = Writable bit	U = Unimplemented bit, read as '0'
u = Bit is unchanged	x = Bit is unknown	-n/n = Value at POR and BOR/Value at all other Resets
'1' = Bit is set	'0' = Bit is cleared	

bit 7-0 **ADPREV<15:8>**: Previous ADC Results Most Significant Byte
If ADPSIS = 1:
 Most Significant Byte of ADFLTR at the start of current ADC conversion
If ADPSIS = 0:
 Most Significant bits of ADRES at the start of current ADC conversion⁽¹⁾

Note 1: If ADPSIS = 0, ADPREVH and ADPREVL are formatted the same way as ADRES is, depending on the ADFRM bit.

PIC16(L)F18856/76

REGISTER 23-21: ADPREVL: ADC PREVIOUS RESULT REGISTER

R-x	R-x	R-x	R-x	R-x	R-x	R-x	R-x
ADPREV<7:0>							
bit 7							bit 0

Legend:

R = Readable bit	W = Writable bit	U = Unimplemented bit, read as '0'
u = Bit is unchanged	x = Bit is unknown	-n/n = Value at POR and BOR/Value at all other Resets
'1' = Bit is set	'0' = Bit is cleared	

bit 7-0 **ADPREV<7:0>**: Previous ADC Results Least Significant Byte
 If ADPSIS = 1:
 Least Significant Byte of ADFLTR at the start of current ADC conversion
 If ADPSIS = 0:
 Least Significant bits of ADRES at the start of current ADC conversion⁽¹⁾

Note 1: If ADPSIS = 0, ADPREVH and ADPREVL are formatted the same way as ADRES is, depending on the ADFRM bit.

REGISTER 23-22: ADACCH: ADC ACCUMULATOR REGISTER HIGH

R/W-x/u	R/W-x/u	R/W-x/u	R/W-x/u	R/W-x/u	R/W-x/u	R/W-x/u	R/W-x/u
ADACC<15:8>							
bit 7							bit 0

Legend:

R = Readable bit	W = Writable bit	U = Unimplemented bit, read as '0'
u = Bit is unchanged	x = Bit is unknown	-n/n = Value at POR and BOR/Value at all other Resets
'1' = Bit is set	'0' = Bit is cleared	

bit 7-0 **ADACC<15:8>**: ADC Accumulator MSB. Most Significant seven bits of accumulator value and sign bit.

REGISTER 23-23: ADACCL: ADC ACCUMULATOR REGISTER LOW

R/W-x/u	R/W-x/u	R/W-x/u	R/W-x/u	R/W-x/u	R/W-x/u	R/W-x/u	R/W-x/u
ADACC<7:0>							
bit 7							bit 0

Legend:

R = Readable bit	W = Writable bit	U = Unimplemented bit, read as '0'
u = Bit is unchanged	x = Bit is unknown	-n/n = Value at POR and BOR/Value at all other Resets
'1' = Bit is set	'0' = Bit is cleared	

bit 7-0 **ADACC<7:0>**: ADC Accumulator LSB. Least Significant eight bits of accumulator value.

PIC16(L)F18856/76

REGISTER 23-24: ADSTPTH: ADC THRESHOLD SETPOINT REGISTER HIGH

R/W-x/u	R/W-x/u	R/W-x/u	R/W-x/u	R/W-x/u	R/W-x/u	R/W-x/u	R/W-x/u
ADSTPT<15:8>							
bit 7							bit 0

Legend:

R = Readable bit	W = Writable bit	U = Unimplemented bit, read as '0'
u = Bit is unchanged	x = Bit is unknown	-n/n = Value at POR and BOR/Value at all other Resets
'1' = Bit is set	'0' = Bit is cleared	

bit 7-0 **ADSTPT<15:8>**: ADC Threshold Setpoint MSB. Most Significant Byte of ADC threshold setpoint, depending on ADCALC, may be used to determine ADERR, see [Register 21-1](#) for more details.

REGISTER 23-25: ADSTPTL: ADC THRESHOLD SETPOINT REGISTER LOW

R/W-x/x	R/W-x/x	R/W-x/x	R/W-x/x	R/W-x/x	R/W-x/x	R/W-x/x	R/W-x/x
ADSTPT<7:0>							
bit 7							bit 0

Legend:

R = Readable bit	W = Writable bit	U = Unimplemented bit, read as '0'
u = Bit is unchanged	x = Bit is unknown	-n/n = Value at POR and BOR/Value at all other Resets
'1' = Bit is set	'0' = Bit is cleared	

bit 7-0 **ADSTPT<7:0>**: ADC Threshold Setpoint LSB. Least Significant Byte of ADC threshold setpoint, depending on ADCALC, may be used to determine ADERR, see [Register 21-1](#) for more details.

REGISTER 23-26: ADERRH: ADC CALCULATION ERROR REGISTER HIGH

R-x	R-x	R-x	R-x	R-x	R-x	R-x	R-x
ADERR<15:8>							
bit 7							bit 0

Legend:

R = Readable bit	W = Writable bit	U = Unimplemented bit, read as '0'
u = Bit is unchanged	x = Bit is unknown	-n/n = Value at POR and BOR/Value at all other Resets
'1' = Bit is set	'0' = Bit is cleared	

bit 7-0 **ADERR<15:8>**: ADC Calculation Error MSB. Most Significant Byte of ADC Calculation Error. Calculation is determined by ADCALC bits of ADCON3, see [Register 21-1](#) for more details.

PIC16(L)F18856/76

REGISTER 23-27: ADERRL: ADC CALCULATION ERROR LOW BYTE REGISTER

R-x	R-x	R-x	R-x	R-x	R-x	R-x	R-x
ADERR<7:0>							
bit 7							bit 0

Legend:

R = Readable bit	W = Writable bit	U = Unimplemented bit, read as '0'
u = Bit is unchanged	x = Bit is unknown	-n/n = Value at POR and BOR/Value at all other Resets
'1' = Bit is set	'0' = Bit is cleared	

bit 7-0 **ADERR<7:0>**: ADC Calculation Error LSB. Least Significant Byte of ADC Calculation Error. Calculation is determined by ADCALC bits of ADCON3, see [Register 21-1](#) for more details.

REGISTER 23-28: ADLTHH: ADC LOWER THRESHOLD HIGH BYTE REGISTER

R/W-x/x	R/W-x/x	R/W-x/x	R/W-x/x	R/W-x/x	R/W-x/x	R/W-x/x	R/W-x/x
ADLTH<15:8>							
bit 7							bit 0

Legend:

R = Readable bit	W = Writable bit	U = Unimplemented bit, read as '0'
u = Bit is unchanged	x = Bit is unknown	-n/n = Value at POR and BOR/Value at all other Resets
'1' = Bit is set	'0' = Bit is cleared	

bit 7-0 **ADLTH<15:8>**: ADC Lower Threshold MSB. ADLTH and ADUTH are compared with ADERR to set the ADUTHR and ADLTHR bits of ADSTAT. Depending on the setting of ADTMD, an interrupt may be triggered by the results of this comparison.

REGISTER 23-29: ADLTHL: ADC LOWER THRESHOLD LOW BYTE REGISTER

R/W-x/x	R/W-x/x	R/W-x/x	R/W-x/x	R/W-x/x	R/W-x/x	R/W-x/x	R/W-x/x
ADLTH<7:0>							
bit 7							bit 0

Legend:

R = Readable bit	W = Writable bit	U = Unimplemented bit, read as '0'
u = Bit is unchanged	x = Bit is unknown	-n/n = Value at POR and BOR/Value at all other Resets
'1' = Bit is set	'0' = Bit is cleared	

bit 7-0 **ADLTH<7:0>**: ADC Lower Threshold LSB. ADLTH and ADUTH are compared with ADERR to set the ADUTHR and ADLTHR bits of ADSTAT. Depending on the setting of ADTMD, an interrupt may be triggered by the results of this comparison.

PIC16(L)F18856/76

REGISTER 23-30: ADUTHH: ADC UPPER THRESHOLD HIGH BYTE REGISTER

R/W-x/x	R/W-x/x	R/W-x/x	R/W-x/x	R/W-x/x	R/W-x/x	R/W-x/x	R/W-x/x
ADUTH<15:8>							
bit 7							bit 0

Legend:

R = Readable bit	W = Writable bit	U = Unimplemented bit, read as '0'
u = Bit is unchanged	x = Bit is unknown	-n/n = Value at POR and BOR/Value at all other Resets
'1' = Bit is set	'0' = Bit is cleared	

bit 7-0 **ADUTH<15:8>**: ADC Upper Threshold MSB. ADLTH and ADUTH are compared with ADERR to set the ADUTHR and ADLTHR bits of ADSTAT. Depending on the setting of ADTMD, an interrupt may be triggered by the results of this comparison.

REGISTER 23-31: ADUTHL: ADC UPPER THRESHOLD LOW BYTE REGISTER

R/W-x/x	R/W-x/x	R/W-x/x	R/W-x/x	R/W-x/x	R/W-x/x	R/W-x/x	R/W-x/x
ADUTH<7:0>							
bit 7							bit 0

Legend:

R = Readable bit	W = Writable bit	U = Unimplemented bit, read as '0'
u = Bit is unchanged	x = Bit is unknown	-n/n = Value at POR and BOR/Value at all other Resets
'1' = Bit is set	'0' = Bit is cleared	

bit 7-0 **ADUTH<7:0>**: ADC Upper Threshold LSB. ADLTH and ADUTH are compared with ADERR to set the ADUTHR and ADLTHR bits of ADSTAT. Depending on the setting of ADTMD, an interrupt may be triggered by the results of this comparison.

PIC16(L)F18856/76

REGISTER 23-32: ADOACT: ADC AUTO CONVERSION TRIGGER CONTROL REGISTER

U-0	U-0	U-0	R/W-0/0	R/W-0/0	R/W-0/0	R/W-0/0	R/W-0/0
—	—	—	ADOACT<4:0>				
bit 7							bit 0

Legend:

R = Readable bit

W = Writable bit

U = Unimplemented bit, read as '0'

u = Bit is unchanged

x = Bit is unknown

-n/n = Value at POR and BOR/Value at all other Resets

'1' = Bit is set

'0' = Bit is cleared

bit 7-5

Unimplemented: Read as '0'

bit 4-0

ADOACT<4:0>: Auto-Conversion Trigger Select Bits

See [Table 23-2](#).

PIC16(L)F18856/76

TABLE 23-6: SUMMARY OF REGISTERS ASSOCIATED WITH ADC

Name	Bit 7	Bit 6	Bit 5	Bit 4	Bit 3	Bit 2	Bit 1	Bit 0	Register on Page
ADCON0	ADON	ADCONT	—	ADCS	—	ADFRM0	—	ADGO	357
ADCON1	ADPPOL	ADIPEN	ADGPOL	—	—	—	—	ADDSSEN	358
ADCON2	ADPSIS	ADCRS<2:0>			ADACL	ADMD<2:0>			359
ADCON3	—	ADCALC<2:0>			ADSOI	ADTMD<2:0>			360
ADACT	—	—	—	ADACT<4:0>					359
ADACCH	ADACCH								369
ADACCL	ADACCL								369
ADPREVH	ADPREVH								368
ADPREVL	ADPREVL								369
ADRESH	ADRESH								367
ADRESL	ADRESL								367
ADSTAT	ADAOV	ADUTHR	ADLTHR	ADMATH	—	ADSTAT<2:0>			361
ADCLK	—	—	ADCCS<5:0>						362
ADREF	—	—	—	ADNREF	—	—	ADPREF<1:0>		362
ADCAP	—	—	—	ADCAP<4:0>					365
ADPRE	ADPRE<7:0>								364
ADACQ	ADACQ<7:0>								364
ADPCH	—	—	ADPCH<5:0>						363
ADCNT	ADCNT<7:0>								366
ADRPT	ADRPT<7:0>								365
ADLTHL	ADLTH<7:0>								371
ADLTHH	ADLTH<15:8>								371
ADUTHL	ADUTH<7:0>								372
ADUTHH	ADUTH<15:8>								372
ADSTPTL	ADSTPT<7:0>								370
ADSTPTH	ADSTPT<15:8>								370
ADFLTRL	ADFLTR<7:0>								366
ADFLTRH	ADFLTR<15:8>								366
ADERRL	ADERR<7:0>								371
ADERRH	ADERR<15:8>								370
ANSELA	ANSA7	ANSA6	ANSA5	ANSA4	ANSA3	ANSA2	ANSA1	ANSA0	205
ANSELB	ANSB7	ANSB6	ANSB5	ANSB4	ANSB3	ANSB2	ANSB1	ANSB0	213
ANSELC	ANSC7	ANSC6	ANSC5	ANSC4	ANSC3	ANSC2	ANSC1	ANSC0	221
ANSELD ⁽¹⁾	ANS7	ANS6	ANS5	ANS4	ANS3	ANS2	ANS1	ANS0	228
ANSELE	—	—	—	—	ANSE3	ANSE2 ⁽¹⁾	ANSE1 ⁽¹⁾	ANSE0 ⁽¹⁾	238
DAC1CON1	—	—	—	DAC1R<4:0>					389
FVRCON	FVREN	FVRRDY	TSEN	TSRNG	CDAFVR<1:0>		ADFVR<1:0>		269
INTCON	GIE	PEIE	—	—	—	—	—	INTEDG	134
PIE1	OSFIE	CSWIE	—	—	—	—	ADTIE	ADIE	136
PIR1	OSFIF	CSWIF	—	—	—	—	ADTIF	ADIF	145
OSCSTAT	EXTOR	HFOR	MFOR	LFOR	SOR	ADOR	—	PLLOR	124

Legend: — = unimplemented read as '0'. Shaded cells are not used for the ADC module.

Note 1: PIC16(L)F18876 only.

PIC16(L)F18856/76

NOTES:

24.0 NUMERICALLY CONTROLLED OSCILLATOR (NCO) MODULE

The Numerically Controlled Oscillator (NCO) module is a timer that uses overflow from the addition of an increment value to divide the input frequency. The advantage of the addition method over simple counter driven timer is that the output frequency resolution does not vary with the divider value. The NCO is most useful for application that requires frequency accuracy and fine resolution at a fixed duty cycle.

Features of the NCO include:

- 20-bit Increment Function
- Fixed Duty Cycle mode (FDC) mode
- Pulse Frequency (PF) mode
- Output Pulse Width Control
- Multiple Clock Input Sources
- Output Polarity Control
- Interrupt Capability

Figure 24-1 is a simplified block diagram of the NCO module.

FIGURE 24-1: DIRECT DIGITAL SYNTHESIS MODULE SIMPLIFIED BLOCK DIAGRAM

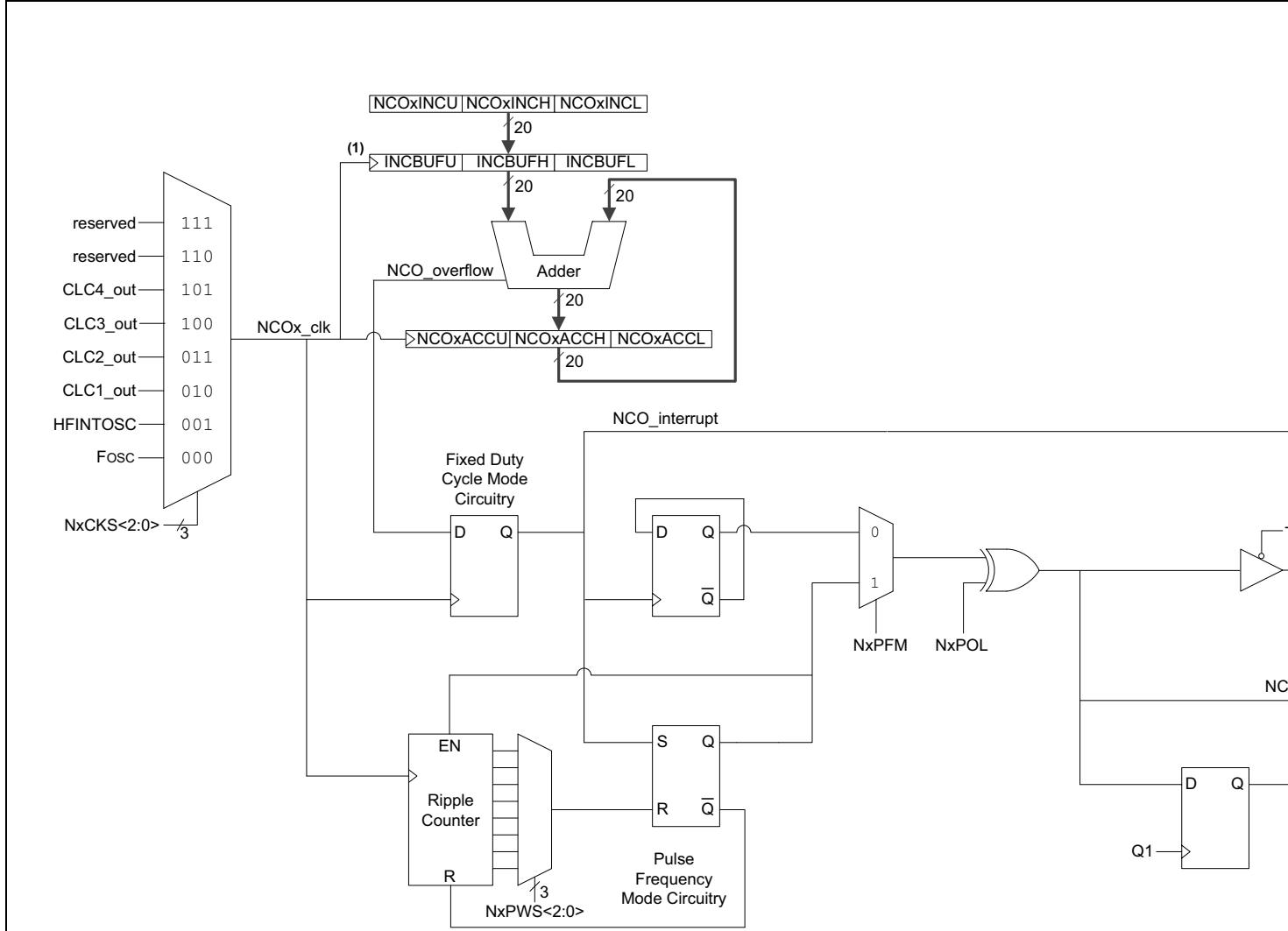

Note 1: The increment registers are double-buffered to allow for value changes to be made without first disabling the NCO module. The full increment value is loaded on the second rising edge of the `NCOx_clk` signal that occurs immediately after a write to `NCOxINCL` register. The buffers are not user-accessible and are shown here for informational purposes only.

PIC16(L)F18856/76

24.1 NCO OPERATION

The NCO operates by repeatedly adding a fixed value to an accumulator. Additions occur at the input clock rate. The accumulator will overflow with a carry periodically, which is the raw NCO output (NCO_overflow). This effectively reduces the input clock by the ratio of the addition value to the maximum accumulator value. See [Equation 24-1](#).

The NCO output can be further modified by stretching the pulse or toggling a flip-flop. The modified NCO output is then distributed internally to other peripherals and can be optionally output to a pin. The accumulator overflow also generates an interrupt (NCO_overflow).

The NCO period changes in discrete steps to create an average frequency. This output depends on the ability of the receiving circuit (i.e., CWG or external resonant converter circuitry) to average the NCO output to reduce uncertainty.

EQUATION 24-1: NCO OVERFLOW FREQUENCY

$$F_{OVERFLOW} = \frac{\text{NCO Clock Frequency} \times \text{Increment Value}}{2^{20}}$$

24.1.1 NCO CLOCK SOURCES

Clock sources available to the NCO include:

- HFINTOSC
- Fosc
- LC1_out
- LC2_out
- LC3_out
- LC4_out

The NCO clock source is selected by configuring the N1CKS<2:0> bits in the NCO1CLK register.

24.1.2 ACCUMULATOR

The accumulator is a 20-bit register. Read and write access to the accumulator is available through three registers:

- NCO1ACCL
- NCO1ACCH
- NCO1ACCU

24.1.3 ADDER

The NCO Adder is a full adder, which operates independently from the source clock. The addition of the previous result and the increment value replaces the accumulator value on the rising edge of each input clock.

24.1.4 INCREMENT REGISTERS

The increment value is stored in three registers making up a 20-bit incrementer. In order of LSB to MSB they are:

- NCO1INCL
- NCO1INCH
- NCO1INCU

When the NCO module is enabled, the NCO1INCU and NCO1INCH registers should be written first, then the NCO1INCL register. Writing to the NCO1INCL register initiates the increment buffer registers to be loaded simultaneously on the second rising edge of the NCO_clk signal.

The registers are readable and writable. The increment registers are double-buffered to allow value changes to be made without first disabling the NCO module.

When the NCO module is disabled, the increment buffers are loaded immediately after a write to the increment registers.

Note: The increment buffer registers are not user-accessible.

PIC16(L)F18856/76

24.2 FIXED DUTY CYCLE MODE

In Fixed Duty Cycle (FDC) mode, every time the accumulator overflows (NCO_overflow), the output is toggled. This provides a 50% duty cycle, provided that the increment value remains constant. For more information, see [Figure 24-2](#).

The FDC mode is selected by clearing the N1PFM bit in the NCO1CON register.

24.3 PULSE FREQUENCY MODE

In Pulse Frequency (PF) mode, every time the Accumulator overflows, the output becomes active for one or more clock periods. Once the clock period expires, the output returns to an inactive state. This provides a pulsed output. The output becomes active on the rising clock edge immediately following the overflow event. For more information, see [Figure 24-2](#).

The value of the active and inactive states depends on the polarity bit, N1POL in the NCO1CON register.

The PF mode is selected by setting the N1PFM bit in the NCO1CON register.

24.3.1 OUTPUT PULSE WIDTH CONTROL

When operating in PF mode, the active state of the output can vary in width by multiple clock periods. Various pulse widths are selected with the N1PWS<2:0> bits in the NCO1CLK register.

When the selected pulse width is greater than the Accumulator overflow time frame, then DDS operation is undefined.

24.4 OUTPUT POLARITY CONTROL

The last stage in the NCO module is the output polarity. The N1POL bit in the NCO1CON register selects the output polarity. Changing the polarity while the interrupts are enabled will cause an interrupt for the resulting output transition.

The NCO output signal is available to the following peripherals:

- CLC
- CWG
- Timer1/3/5
- Timer2/4/6
- SMT
- DSM
- Reference Clock Output

24.5 Interrupts

When the accumulator overflows (NCO_overflow), the NCO Interrupt Flag bit, NCO1IF, of the PIR7 register is set. To enable the interrupt event (NCO_interrupt), the following bits must be set:

- N1EN bit of the NCO1CON register
- NCO1IE bit of the PIE7 register
- PEIE bit of the INTCON register
- GIE bit of the INTCON register

The interrupt must be cleared by software by clearing the NCO1IF bit in the Interrupt Service Routine.

24.6 Effects of a Reset

All of the NCO registers are cleared to zero as the result of a Reset.

24.7 Operation in Sleep

The NCO module operates independently from the system clock and will continue to run during Sleep, provided that the clock source selected remains active.

The HFINTOSC remains active during Sleep when the NCO module is enabled and the HFINTOSC is selected as the clock source, regardless of the system clock source selected.

In other words, if the HFINTOSC is simultaneously selected as the system clock and the NCO clock source, when the NCO is enabled, the CPU will go idle during Sleep, but the NCO will continue to operate and the HFINTOSC will remain active.

This will have a direct effect on the Sleep mode current.

FIGURE 24-2: FDC OUTPUT MODE OPERATION DIAGRAM

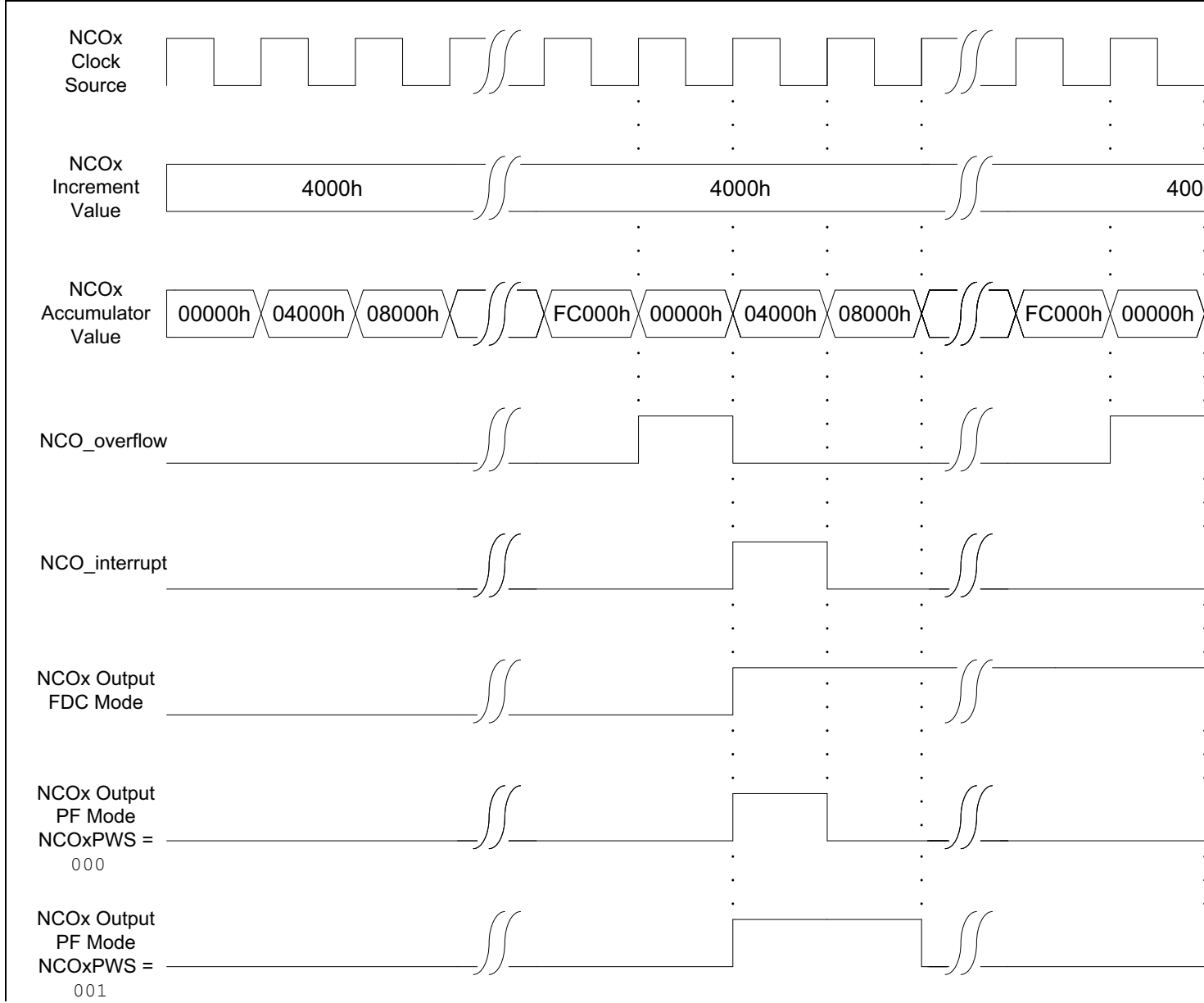

PIC16(L)F18856/76

24.8 NCO Control Registers

REGISTER 24-1: NCO1CON: NCO CONTROL REGISTER

R/W-0/0	U-0	R-0/0	R/W-0/0	U-0	U-0	U-0	R/W-0/0
N1EN	—	N1OUT	N1POL	—	—	—	N1PFM
bit 7							bit 0

Legend:

R = Readable bit

W = Writable bit

U = Unimplemented bit, read as '0'

u = Bit is unchanged

x = Bit is unknown

-n/n = Value at POR and BOR/Value at all other Resets

'1' = Bit is set

'0' = Bit is cleared

- bit 7 **N1EN:** NCO1 Enable bit
1 = NCO1 module is enabled
0 = NCO1 module is disabled
- bit 6 **Unimplemented:** Read as '0'
- bit 5 **N1OUT:** NCO1 Output bit
Displays the current output value of the NCO1 module.
- bit 4 **N1POL:** NCO1 Polarity
1 = NCO1 output signal is inverted
0 = NCO1 output signal is not inverted
- bit 3-1 **Unimplemented:** Read as '0'
- bit 0 **N1PFM:** NCO1 Pulse Frequency Mode bit
1 = NCO1 operates in Pulse Frequency mode
0 = NCO1 operates in Fixed Duty Cycle mode, divide by 2

PIC16(L)F18856/76

REGISTER 24-2: NCO1CLK: NCO1 INPUT CLOCK CONTROL REGISTER

R/W-0/0	R/W-0/0	R/W-0/0	U-0	U-0	R/W-0/0	R/W-0/0	R/W-0/0
N1PWS<2:0> ^(1,2)			—	—	N1CKS<2:0>		
bit 7					bit 0		

Legend:

R = Readable bit	W = Writable bit	U = Unimplemented bit, read as '0'
u = Bit is unchanged	x = Bit is unknown	-n/n = Value at POR and BOR/Value at all other Resets
'1' = Bit is set	'0' = Bit is cleared	

bit 7-5 **N1PWS<2:0>**: NCO1 Output Pulse Width Select bits^(1,2)
 111 = NCO1 output is active for 128 input clock periods
 110 = NCO1 output is active for 64 input clock periods
 101 = NCO1 output is active for 32 input clock periods
 100 = NCO1 output is active for 16 input clock periods
 011 = NCO1 output is active for 8 input clock periods
 010 = NCO1 output is active for 4 input clock periods
 001 = NCO1 output is active for 2 input clock periods
 000 = NCO1 output is active for 1 input clock period

bit 4-3 **Unimplemented**: Read as '0'

bit 2-0 **N1CKS<2:0>**: NCO1 Clock Source Select bits
 110 = Reserved
 •
 •
 •
 111 = Reserved
 101 = LC4_out
 100 = LC3_out
 011 = LC2_out
 010 = LC1_out
 001 = HFINTOSC
 000 = FOSC

Note 1: N1PWS applies only when operating in Pulse Frequency mode.
Note 2: If NCO1 pulse width is greater than NCO1 overflow period, operation is undefined.

PIC16(L)F18856/76

REGISTER 24-3: NCO1ACCL: NCO1 ACCUMULATOR REGISTER – LOW BYTE

R/W-0/0	R/W-0/0	R/W-0/0	R/W-0/0	R/W-0/0	R/W-0/0	R/W-0/0	R/W-0/0
NCO1ACC<7:0>							
bit 7							bit 0

Legend:

R = Readable bit W = Writable bit U = Unimplemented bit, read as '0'
u = Bit is unchanged x = Bit is unknown -n/n = Value at POR and BOR/Value at all other Resets
'1' = Bit is set '0' = Bit is cleared

bit 7-0 **NCO1ACC<7:0>**: NCO1 Accumulator, Low Byte

REGISTER 24-4: NCO1ACCH: NCO1 ACCUMULATOR REGISTER – HIGH BYTE

R/W-0/0	R/W-0/0	R/W-0/0	R/W-0/0	R/W-0/0	R/W-0/0	R/W-0/0	R/W-0/0
NCO1ACC<15:8>							
bit 7							bit 0

Legend:

R = Readable bit W = Writable bit U = Unimplemented bit, read as '0'
u = Bit is unchanged x = Bit is unknown -n/n = Value at POR and BOR/Value at all other Resets
'1' = Bit is set '0' = Bit is cleared

bit 7-0 **NOC1ACC<15:8>**: NCO1 Accumulator, High Byte

REGISTER 24-5: NCO1ACCU: NCO1 ACCUMULATOR REGISTER – UPPER BYTE⁽¹⁾

U-0	U-0	U-0	U-0	R/W-0/0	R/W-0/0	R/W-0/0	R/W-0/0
—	—	—	—	NCO1ACC<19:16>			
bit 7							bit 0

Legend:

R = Readable bit W = Writable bit U = Unimplemented bit, read as '0'
u = Bit is unchanged x = Bit is unknown -n/n = Value at POR and BOR/Value at all other Resets
'1' = Bit is set '0' = Bit is cleared

bit 7-4 **Unimplemented:** Read as '0'

bit 3-0 **NCO1ACC<19:16>**: NCO1 Accumulator, Upper Byte

Note 1: The accumulator spans registers NCO1ACCU:NCO1ACCH: NCO1ACCL. The 24 bits are reserved but not all are used. This register updates in real-time, asynchronously to the CPU; there is no provision to guarantee atomic access to this 24-bit space using an 8-bit bus. Writing to this register while the module is operating will produce undefined results.

PIC16(L)F18856/76

REGISTER 24-6: NCO1INCL: NCO1 INCREMENT REGISTER – LOW BYTE^(1,2)

R/W-0/0	R/W-0/0	R/W-0/0	R/W-0/0	R/W-0/0	R/W-0/0	R/W-0/0	R/W-1/1
NCO1INC<7:0>							
bit 7							bit 0

Legend:

R = Readable bit	W = Writable bit	U = Unimplemented bit, read as '0'
u = Bit is unchanged	x = Bit is unknown	-n/n = Value at POR and BOR/Value at all other Resets
'1' = Bit is set	'0' = Bit is cleared	

bit 7-0 **NCO1INC<7:0>**: NCO1 Increment, Low Byte

- Note 1:** The logical increment spans NCO1INC_U:NCO1INC_H:NCO1INCL.
Note 2: DDSINC is double-buffered as INCBUF; INCBUF is updated on the next falling edge of NCOCLK after writing to NCO1INCL; NCO1INC_U and NCO1INC_H should be written prior to writing NCO1INCL.

REGISTER 24-7: NCO1INCH: NCO1 INCREMENT REGISTER – HIGH BYTE⁽¹⁾

R/W-0/0	R/W-0/0	R/W-0/0	R/W-0/0	R/W-0/0	R/W-0/0	R/W-0/0	R/W-0/0
NCO1INC<15:8>							
bit 7							bit 0

Legend:

R = Readable bit	W = Writable bit	U = Unimplemented bit, read as '0'
u = Bit is unchanged	x = Bit is unknown	-n/n = Value at POR and BOR/Value at all other Resets
'1' = Bit is set	'0' = Bit is cleared	

bit 7-0 **NCO1INC<15:8>**: NCO1 Increment, High Byte

- Note 1:** The logical increment spans NCO1INC_U:NCO1INC_H:NCO1INCL.

REGISTER 24-8: NCO1INC_U: NCO1 INCREMENT REGISTER – UPPER BYTE⁽¹⁾

U-0	U-0	U-0	U-0	R/W-0/0	R/W-0/0	R/W-0/0	R/W-0/0
—	—	—	—	NCO1INC<19:16>			
bit 7							bit 0

Legend:

R = Readable bit	W = Writable bit	U = Unimplemented bit, read as '0'
u = Bit is unchanged	x = Bit is unknown	-n/n = Value at POR and BOR/Value at all other Resets
'1' = Bit is set	'0' = Bit is cleared	

bit 7-4 **Unimplemented:** Read as '0'

bit 3-0 **NCO1INC<19:16>**: NCO1 Increment, Upper Byte

- Note 1:** The logical increment spans NCO1INC_U:NCO1INC_H:NCO1INCL.

PIC16(L)F18856/76

TABLE 24-1: SUMMARY OF REGISTERS ASSOCIATED WITH NCO

Name	Bit 7	Bit 6	Bit 5	Bit 4	Bit 3	Bit 2	Bit 1	Bit 0	Register on Page
ANSELA	ANSA7	ANSA6	ANSA5	ANSA4	ANSA3	ANSA2	ANSA1	ANSA0	205
ANSELC	ANSC7	ANSC6	ANSC5	ANSC4	ANSC3	ANSC2	ANSC1	ANSC0	221
INTCON	GIE	PEIE	—	—	—	—	—	INTEDG	134
PIR2	—	ZCDIF	—	—	—	—	C2IF	C1IF	146
PIE2	—	ZCDIE	—	—	—	—	C2IE	C1IE	137
NCO1CON	N1EN	—	N1OUT	N1POL	—	—	—	N1PFM	381
NCO1CLK	N1PWS<2:0>			—	—	N1CKS<2:0>			382
NCO1ACCL	NCO1ACC<7:0>								383
NCO1ACCH	NCO1ACC<15:8>								383
NCO1ACCU	—	—	—	—	NCO1ACC<19:16>				383
NCO1INCL	NCO1INC<7:0>								384
NCO1INCH	NCO1INC<15:8>								384
NCO1INCU	—	—	—	—	NCO1INC<19:16>				384
RxyPPS	—	—	—	RxyPPS<4:0>					250
CWG1ISM	—	—	—	—	IS<3:0>				312
MDSRC	—	—	—	MDMS<4:0>					399
MDCARH	—	—	—	—	MDCHS<3:0>				400
MDCARL	—	—	—	—	MDCLS<3:0>				401
CCP1CAP	—	—	—	—	—	CTS<2:0>			454
CCP2CAP	—	—	—	—	—	CTS<2:0>			454
CCP3CAP	—	—	—	—	—	CTS<2:0>			454
CCP4CAP	—	—	—	—	—	CTS<2:0>			454
CCP5CAP	—	—	—	—	—	CTS<2:0>			454
TRISA	TRISA7	TRISA6	TRISA5	TRISA4	TRISA3	TRISA2	TRISA1	TRISA0	204
TRISC	TRISC7	TRISC6	TRISC5	TRISC4	TRISC3	TRISC2	TRISC1	TRISC0	220

Legend: — = unimplemented read as '0'. Shaded cells are not used for NCO module.

PIC16(L)F18856/76

25.0 5-BIT DIGITAL-TO-ANALOG CONVERTER (DAC1) MODULE

The Digital-to-Analog Converter supplies a variable voltage reference, ratiometric with the input source, with 32 selectable output levels.

The input of the DAC can be connected to:

- External VREF pins
- VDD supply voltage
- FVR (Fixed Voltage Reference)

The output of the DAC can be configured to supply a reference voltage to the following:

- Comparator positive input
- ADC input channel
- DAC1OUT pin

The Digital-to-Analog Converter (DAC) is enabled by setting the DAC1EN bit of the DAC1CON0 register.

25.1 Output Voltage Selection

The DAC has 32 voltage level ranges. The 32 levels are set with the DAC1R<4:0> bits of the DAC1CON1 register.

The DAC output voltage is determined by [Equation 25-1](#):

EQUATION 25-1: DAC OUTPUT VOLTAGE

$$V_{OUT} = \left((V_{SOURCE+}) - (V_{SOURCE-}) \times \frac{DAC1R\langle 4:0 \rangle}{2^5} \right) + (V_{SOURCE-})$$
$$V_{SOURCE+} = V_{DD} \text{ or } V_{REF+} \text{ or } FVR$$
$$V_{SOURCE-} = V_{SS} \text{ or } V_{REF-}$$

25.2 Ratiometric Output Level

The DAC output value is derived using a resistor ladder with each end of the ladder tied to a positive and negative voltage reference input source. If the voltage of either input source fluctuates, a similar fluctuation will result in the DAC output value.

The value of the individual resistors within the ladder can be found in [Table 37-15](#).

25.3 DAC Voltage Reference Output

The DAC voltage can be output to the DAC1OUT1/2 pins by setting the DAC1OE1/2 bits of the DAC1CON0 register, respectively. Selecting the DAC reference voltage for output on the DAC1OUT1/2 pins automatically overrides the digital output buffer and digital input threshold detector functions, disables the weak pull-up, and disables the current-controlled drive function of that pin. Reading the DAC1OUT1/2 pin when it has been configured for DAC reference voltage output will always return a '0'.

Due to the limited current drive capability, a buffer must be used on the DAC voltage reference output for external connections to the DAC1OUT1/2 pins. [Figure 25-2](#) shows an example buffering technique.

PIC16(L)F18856/76

FIGURE 25-1: DIGITAL-TO-ANALOG CONVERTER BLOCK DIAGRAM

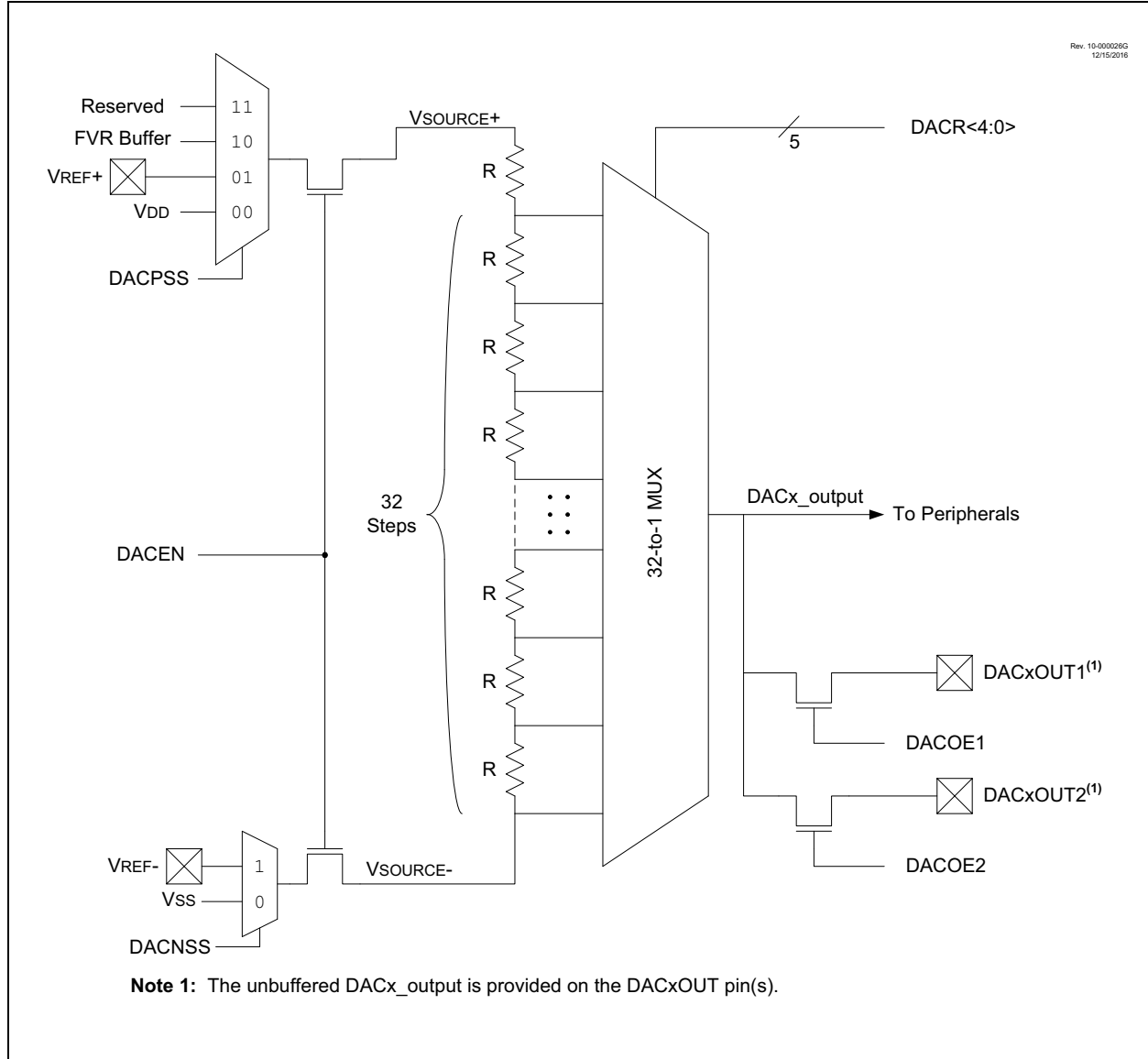
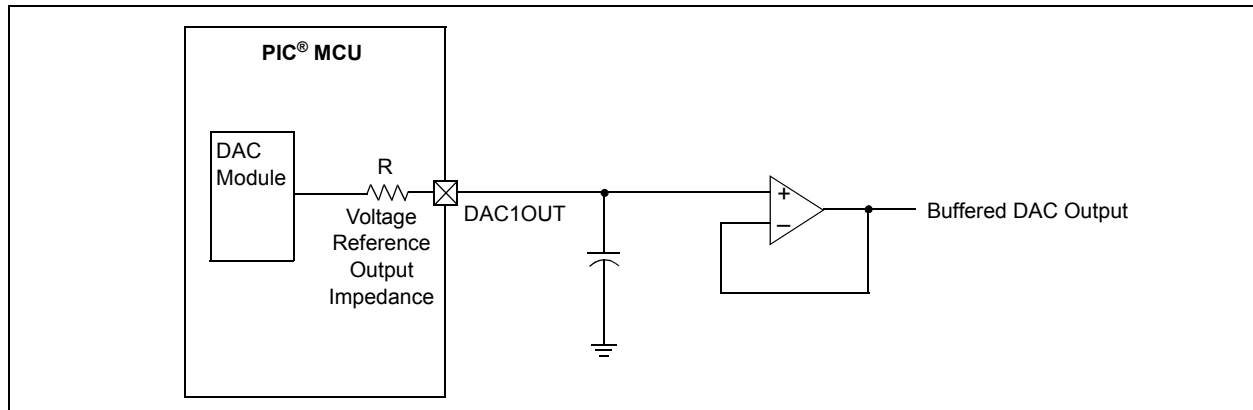

FIGURE 25-2: VOLTAGE REFERENCE OUTPUT BUFFER EXAMPLE



PIC16(L)F18856/76

25.4 Operation During Sleep

The DAC continues to function during Sleep. When the device wakes up from Sleep through an interrupt or a Watchdog Timer time-out, the contents of the DAC1CON0 register are not affected.

25.5 Effects of a Reset

A device Reset affects the following:

- DAC is disabled.
- DAC output voltage is removed from the DAC1OUT1/2 pins.
- The DAC1R<4:0> range select bits are cleared.

PIC16(L)F18856/76

25.6 Register Definitions: DAC Control

REGISTER 25-1: DAC1CON0: VOLTAGE REFERENCE CONTROL REGISTER 0

R/W-0/0	U-0	R/W-0/0	R/W-0/0	R/W-0/0	R/W-0/0	U-0	R/W-0/0
DAC1EN	—	DAC1OE1	DAC1OE2	DAC1PSS<1:0>		—	DAC1NSS
bit 7							bit 0

Legend:

R = Readable bit	W = Writable bit	U = Unimplemented bit, read as '0'
u = Bit is unchanged	x = Bit is unknown	-n/n = Value at POR and BOR/Value at all other Resets
'1' = Bit is set	'0' = Bit is cleared	

bit 7	DAC1EN: DAC1 Enable bit 1 = DAC is enabled 0 = DAC is disabled
bit 6	Unimplemented: Read as '0'
bit 5	DAC1OE1: DAC1 Voltage Output 1 Enable bit 1 = DAC voltage level is also an output on the DAC1OUT1 pin 0 = DAC voltage level is disconnected from the DAC1OUT1 pin
bit 4	DAC1OE2: DAC1 Voltage Output 1 Enable bit 1 = DAC voltage level is also an output on the DAC1OUT2 pin 0 = DAC voltage level is disconnected from the DAC1OUT2 pin
bit 3-2	DAC1PSS<1:0>: DAC1 Positive Source Select bits 11 = Reserved, do not use 10 = FVR output 01 = VREF+ pin 00 = VDD
bit 1	Unimplemented: Read as '0'
bit 0	DAC1NSS: DAC1 Negative Source Select bits 1 = VREF- pin 0 = VSS

REGISTER 25-2: DAC1CON1: VOLTAGE REFERENCE CONTROL REGISTER 1

U-0	U-0	U-0	R/W-0/0	R/W-0/0	R/W-0/0	R/W-0/0	R/W-0/0
—	—	—	DAC1R<4:0>				
bit 7							bit 0

Legend:

R = Readable bit	W = Writable bit	U = Unimplemented bit, read as '0'
u = Bit is unchanged	x = Bit is unknown	-n/n = Value at POR and BOR/Value at all other Resets
'1' = Bit is set	'0' = Bit is cleared	

bit 7-5	Unimplemented: Read as '0'
bit 4-0	DAC1R<4:0>: DAC1 Voltage Output Select bits $V_{OUT} = (V_{SRC+} - V_{SRC-}) * (DAC1R<4:0>/32) + V_{SRC}$

PIC16(L)F18856/76

TABLE 25-1: SUMMARY OF REGISTERS ASSOCIATED WITH THE DAC1 MODULE

Name	Bit 7	Bit 6	Bit 5	Bit 4	Bit 3	Bit 2	Bit 1	Bit 0	Register on page
DAC1CON0	DAC1EN	—	DAC1OE1	DAC1OE2	DAC1PSS<1:0>		—	DAC1NSS	389
DAC1CON1	—	—	—	DAC1R<4:0>					389
CM1PSEL	—	—	—	—	—	PCH<2:0>			281
CM2PSEL	—	—	—	—	—	PCH<2:0>			281
ADPCH	—	—	ADPCH<5:0>						357

Legend: — = Unimplemented location, read as '0'. Shaded cells are not used with the DAC module.

PIC16(L)F18856/76

26.0 DATA SIGNAL MODULATOR (DSM) MODULE

The Data Signal Modulator (DSM) is a peripheral which allows the user to mix a data stream, also known as a modulator signal, with a carrier signal to produce a modulated output.

Both the carrier and the modulator signals are supplied to the DSM module either internally, from the output of a peripheral, or externally through an input pin.

The modulated output signal is generated by performing a logical “AND” operation of both the carrier and modulator signals and then provided to the MDOUT pin.

The carrier signal is comprised of two distinct and separate signals. A carrier high (CARH) signal and a carrier low (CARL) signal. During the time in which the modulator (MOD) signal is in a logic high state, the DSM mixes the carrier high signal with the modulator signal. When the modulator signal is in a logic low state, the DSM mixes the carrier low signal with the modulator signal.

Using this method, the DSM can generate the following types of Key Modulation schemes:

- Frequency-Shift Keying (FSK)
- Phase-Shift Keying (PSK)
- On-Off Keying (OOK)

Additionally, the following features are provided within the DSM module:

- Carrier Synchronization
- Carrier Source Polarity Select
- Carrier Source Pin Disable
- Programmable Modulator Data
- Modulator Source Pin Disable
- Modulated Output Polarity Select
- Slew Rate Control

[Figure 26-1](#) shows a Simplified Block Diagram of the Data Signal Modulator peripheral.

PIC16(L)F18856/76

FIGURE 26-1: SIMPLIFIED BLOCK DIAGRAM OF THE DATA SIGNAL MODULATOR

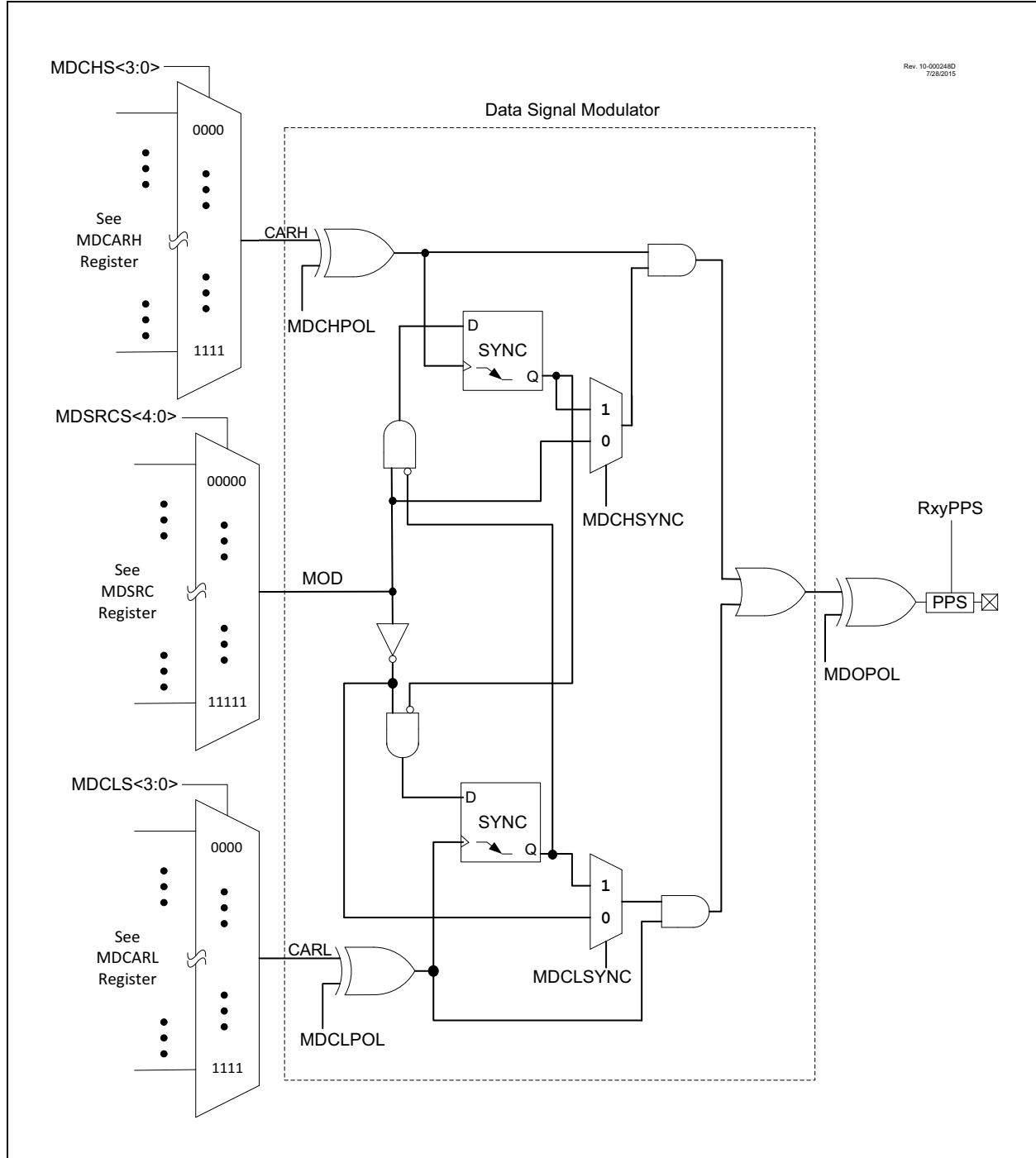

PIC16(L)F18856/76

26.1 DSM Operation

The DSM module can be enabled by setting the MDEN bit in the MDCON register. Clearing the MDEN bit in the MDCON register, disables the DSM module by automatically switching the carrier high and carrier low signals to the Vss signal source. The modulator signal source is also switched to the MDBIT in the MDCON register. This not only assures that the DSM module is inactive, but that it is also consuming the least amount of current.

The values used to select the carrier high, carrier low, and modulator sources held by the Modulation Source, Modulation High Carrier, and Modulation Low Carrier control registers are not affected when the MDEN bit is cleared and the DSM module is disabled. The values inside these registers remain unchanged while the DSM is inactive. The sources for the carrier high, carrier low and modulator signals will once again be selected when the MDEN bit is set and the DSM module is again enabled and active.

The modulated output signal can be disabled without shutting down the DSM module. The DSM module will remain active and continue to mix signals, but the output value will not be sent to the DSM pin. During the time that the output is disabled, the DSM pin will remain low. The modulated output can be disabled by clearing the MDEN bit in the MDCON register.

26.2 Modulator Signal Sources

The modulator signal can be supplied from the following sources:

- External Signal on MDSRCPPS pin
- MDBIT bit in the MDCON0 register
- CCP1 Signal
- CCP2 Signal
- CCP3 Signal
- CCP4 Signal
- CCP5 Signal
- PWM6 Signal
- PWM7 Signal
- NCO output
- Comparator C1 Signal
- Comparator C2 Signal
- CLC1 Output
- CLC2 Output
- CLC3 Output
- CLC4 Output
- EUSART DT Signal
- EUSART TX/CK Signal
- MSSP1 SDO Signal (SPI Mode Only)
- MSSP2 SDO Signal

The modulator signal is selected by configuring the MDMS <4:0> bits in the MDSRC register.

26.3 Carrier Signal Sources

The carrier high signal and carrier low signal can be supplied from the following sources:

- External Signal on MDCARH/LPPS pins
- FOSC (system clock)
- HFINTOSC
- Reference Clock Module Signal
- CCP1 Signal
- CCP2 Signal
- CCP3 Signal
- CCP4 Signal
- CCP5 Signal
- PWM6 Output
- PWM7 Output
- NCO output
- CLC1 output
- CLC2 output
- CLC3 output
- CLC4 output

The carrier high signal is selected by configuring the MDCHS <3:0> bits in the MDCARH register. The carrier low signal is selected by configuring the MDCLS <3:0> bits in the MDCARL register.

26.4 Carrier Synchronization

During the time when the DSM switches between carrier high and carrier low signal sources, the carrier data in the modulated output signal can become truncated. To prevent this, the carrier signal can be synchronized to the modulator signal. When synchronization is enabled, the carrier pulse that is being mixed at the time of the transition is allowed to transition low before the DSM switches over to the next carrier source.

Synchronization is enabled separately for the carrier high and carrier low signal sources. Synchronization for the carrier high signal is enabled by setting the MDCHSYNC bit in the MDCON1 register. Synchronization for the carrier low signal is enabled by setting the MDCLSYNC bit in the MDCON1 register.

Figure 26-1 through Figure 26-6 show timing diagrams of using various synchronization methods.

PIC16(L)F18856/76

FIGURE 26-2: ON OFF KEYING (OOK) SYNCHRONIZATION

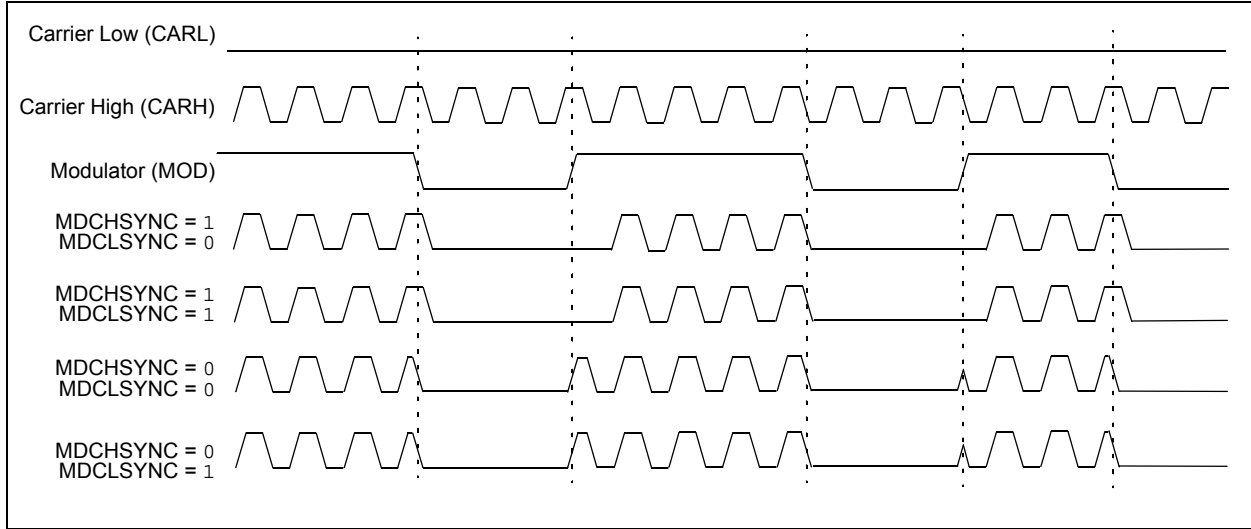

FIGURE 26-3: NO SYNCHRONIZATION (MDSHSYNC = 0, MDCLSYNC = 0)

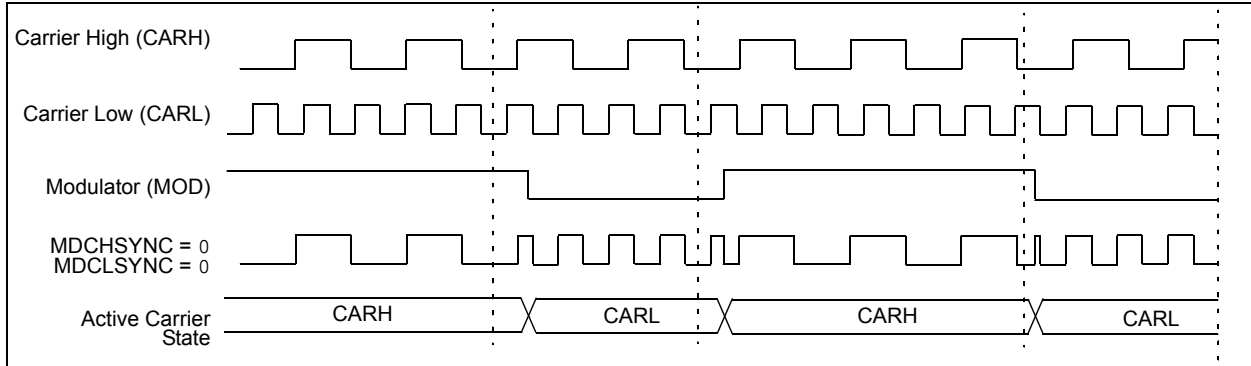
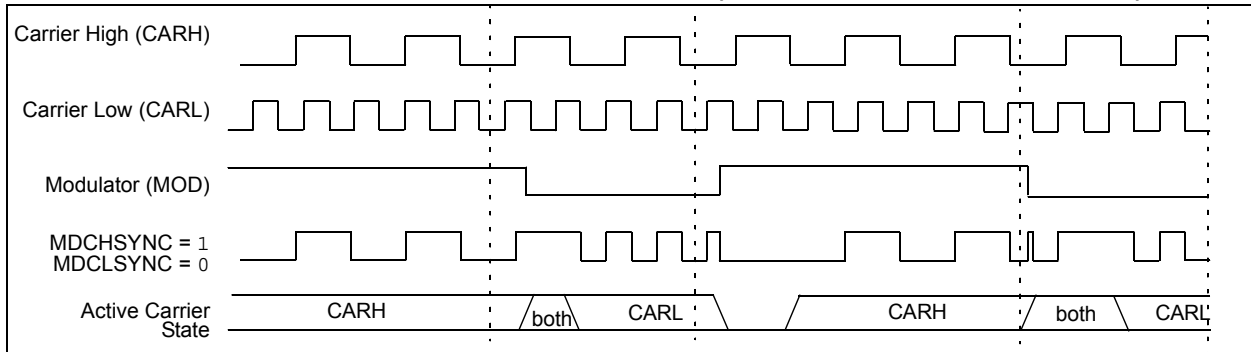

FIGURE 26-4: CARRIER HIGH SYNCHRONIZATION (MDSHSYNC = 1, MDCLSYNC = 0)



PIC16(L)F18856/76

FIGURE 26-5: CARRIER LOW SYNCHRONIZATION (MDSHSYNC = 0, MDCLSYNC = 1)

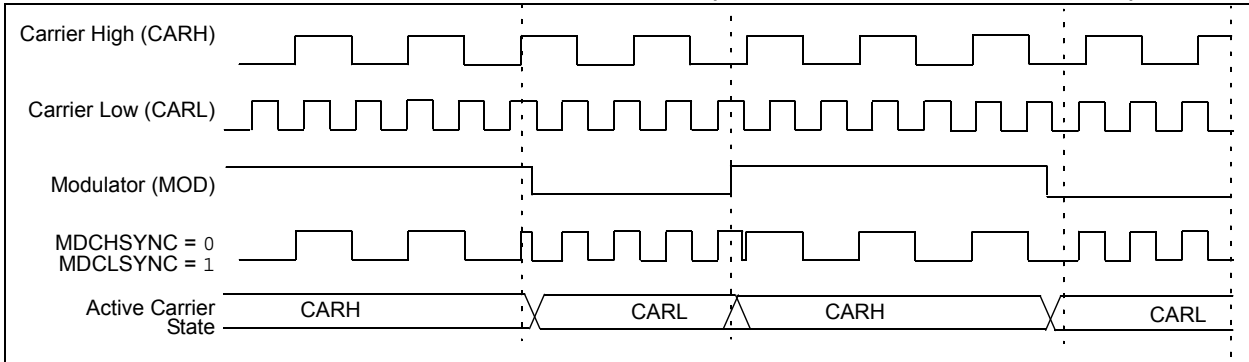
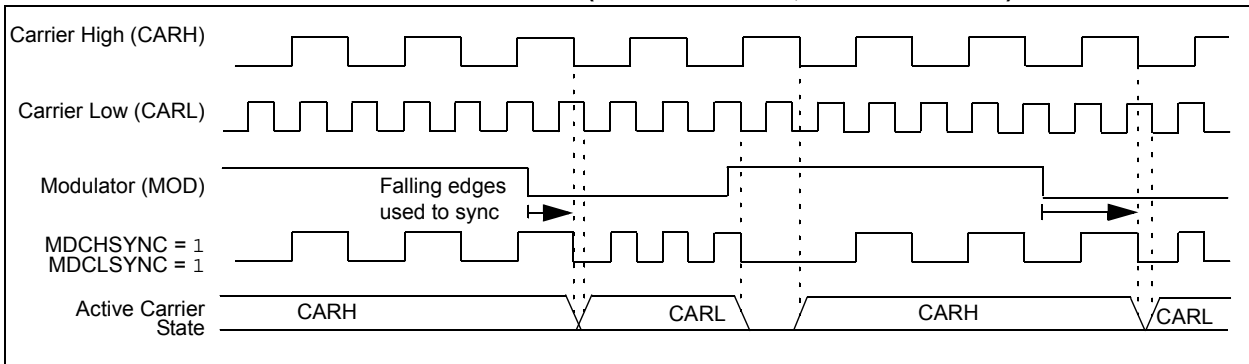

FIGURE 26-6: FULL SYNCHRONIZATION (MDSHSYNC = 1, MDCLSYNC = 1)



PIC16(L)F18856/76

26.5 Carrier Source Polarity Select

The signal provided from any selected input source for the carrier high and carrier low signals can be inverted. Inverting the signal for the carrier high source is enabled by setting the MDCHPOL bit of the MDCON1 register. Inverting the signal for the carrier low source is enabled by setting the MDCLPOL bit of the MDCON1 register.

26.6 Programmable Modulator Data

The MDBIT of the MDCON0 register can be selected as the source for the modulator signal. This gives the user the ability to program the value used for modulation.

26.7 Modulated Output Polarity

The modulated output signal provided on the DSM pin can also be inverted. Inverting the modulated output signal is enabled by setting the MDOPOL bit of the MDCON0 register.

26.8 Slew Rate Control

The slew rate limitation on the output port pin can be disabled. The slew rate limitation can be removed by clearing the SLR bit of the SLRCON register associated with that pin. For example, clearing the slew rate limitation for pin RA5 would require clearing the SLRA5 bit of the SLRCONA register.

26.9 Operation in Sleep Mode

The DSM module is not affected by Sleep mode. The DSM can still operate during Sleep, if the Carrier and Modulator input sources are also still operable during Sleep.

26.10 Effects of a Reset

Upon any device Reset, the DSM module is disabled. The user's firmware is responsible for initializing the module before enabling the output. The registers are reset to their default values.

PIC16(L)F18856/76

26.11 Register Definitions: Modulation Control

REGISTER 26-1: MDCON0: MODULATION CONTROL REGISTER

R/W-0/0	U-0	R/W-0/0	R/W-0/0	U-0	U-0	U-0	R/W-0/0
MDEN	—	MDOUT	MDOPOL	—	—	—	MDBIT ⁽²⁾
bit 7							bit 0

Legend:

R = Readable bit

W = Writable bit

U = Unimplemented bit, read as '0'

u = Bit is unchanged

x = Bit is unknown

-n/n = Value at POR and BOR/Value at all other Resets

'1' = Bit is set

'0' = Bit is cleared

- bit 7 **MDEN:** Modulator Module Enable bit
1 = Modulator module is enabled and mixing input signals
0 = Modulator module is disabled and has no output
- bit 6 **Unimplemented:** Read as '0'
- bit 5 **MDOUT:** Modulator Output bit
Displays the current output value of the modulator module.⁽¹⁾
- bit 4 **MDOPOL:** Modulator Output Polarity Select bit
1 = Modulator output signal is inverted; idle high output
0 = Modulator output signal is not inverted; idle low output
- bit 3-1 **Unimplemented:** Read as '0'
- bit 0 **MDBIT:** Allows software to manually set modulation source input to module⁽²⁾

Note 1: The modulated output frequency can be greater and asynchronous from the clock that updates this register bit, the bit value may not be valid for higher speed modulator or carrier signals.

2: MDBIT must be selected as the modulation source in the MDSRC register for this operation.

PIC16(L)F18856/76

REGISTER 26-2: MDCON1: MODULATION CONTROL REGISTER 1

U-0	U-0	R/W-0/0	R/W-0/0	U-0	U-0	R/W-0/0	R/W-0/0
—	—	MDCHPOL	MDCHSYNC	—	—	MDCLPOL	MDCLSYNC
bit 7							bit 0

Legend:

R = Readable bit

W = Writable bit

U = Unimplemented bit, read as '0'

u = Bit is unchanged

x = Bit is unknown

-n/n = Value at POR and BOR/Value at all other Resets

'1' = Bit is set

'0' = Bit is cleared

bit 7-6 **Unimplemented:** Read as '0'

bit 5 **MDCHPOL:** Modulator High Carrier Polarity Select bit

1 = Selected high carrier signal is inverted

0 = Selected high carrier signal is not inverted

bit 4 **MDCHSYNC:** Modulator High Carrier Synchronization Enable bit

1 = Modulator waits for a falling edge on the high time carrier signal before allowing a switch to the low time carrier

0 = Modulator Output is not synchronized to the high-time carrier signal⁽¹⁾

bit 3-2 **Unimplemented:** Read as '0'

bit 1 **MDCLPOL:** Modulator Low Carrier Polarity Select bit

1 = Selected low carrier signal is inverted

0 = Selected low carrier signal is not inverted

bit 0 **MDCLSYNC:** Modulator Low Carrier Synchronization Enable bit

1 = Modulator waits for a falling edge on the low time carrier signal before allowing a switch to the high-time carrier

0 = Modulator Output is not synchronized to the low-time carrier signal⁽¹⁾

Note 1: Narrowed carrier pulse widths or spurs may occur in the signal stream if the carrier is not synchronized.

PIC16(L)F18856/76

REGISTER 26-3: MDSRC: MODULATION SOURCE CONTROL REGISTER

U-0	U-0	U-0	R/W-x/u	R/W-x/u	R/W-x/u	R/W-x/u	R/W-x/u
—	—	—	MDMS<4:0>				
bit 7							bit 0

Legend:

R = Readable bit	W = Writable bit	U = Unimplemented bit, read as '0'
u = Bit is unchanged	x = Bit is unknown	-n/n = Value at POR and BOR/Value at all other Resets
'1' = Bit is set	'0' = Bit is cleared	

bit 7-5 **Unimplemented:** Read as '0'

bit 4-0 **MDMS<4:0>** Modulation Source Selection bits

11111 = Reserved. No channel connected.

•
•
•

10100 = Reserved. No channel connected.

10011 = MSSP2 SDO

10010 = MSSP1 SDO

10001 = EUSART TX/CK output

10000 = EUSART DT output

01111 = CLC4 output

01110 = CLC3 output

01101 = CLC2 output

01100 = CLC1 output

01011 = C2 (Comparator 2) output

01010 = C1 (Comparator 1) output

01001 = NCO output

01000 = PWM7 output

00111 = PWM6 output

00110 = CCP5 output (PWM Output mode only)

00101 = CCP4 output (PWM Output mode only)

00100 = CCP3 output (PWM Output mode only)

00011 = CCP2 output (PWM Output mode only)

00010 = CCP1 output (PWM Output mode only)

00001 = MDBIT of MDCON0 register is modulation source

00000 = MDSRCPPS

PIC16(L)F18856/76

REGISTER 26-4: MDCARH: MODULATION HIGH CARRIER CONTROL REGISTER

U-0	U-0	U-0	U-0	R/W-x/u	R/W-x/u	R/W-x/u	R/W-x/u
—	—	—	—	MDCHS<3:0> ⁽¹⁾			
bit 7							bit 0

Legend:

R = Readable bit	W = Writable bit	U = Unimplemented bit, read as '0'
u = Bit is unchanged	x = Bit is unknown	-n/n = Value at POR and BOR/Value at all other Resets
'1' = Bit is set	'0' = Bit is cleared	

- bit 7-4 **Unimplemented:** Read as '0'
- bit 3-0 **MDCHS<3:0>** Modulator Data High Carrier Selection bits ⁽¹⁾
 - 1111 = LC4_out
 - 1110 = LC3_out
 - 1101 = LC2_out
 - 1100 = LC1_out
 - 1011 = NCO output
 - 1010 = PWM7_out
 - 1001 = PWM6_out
 - 1000 = CCP5 output (PWM Output mode only)
 - 0111 = CCP4 output (PWM Output mode only)
 - 0110 = CCP3 output (PWM Output mode only)
 - 0101 = CCP2 output (PWM Output mode only)
 - 0100 = CCP1 output (PWM Output mode only)
 - 0011 = Reference clock module signal (CLKR)
 - 0010 = HFINTOSC
 - 0001 = FOSC
 - 0000 = Pin selected by MDCARHPPS

Note 1: Narrowed carrier pulse widths or spurs may occur in the signal stream if the carrier is not synchronized.

PIC16(L)F18856/76

REGISTER 26-5: MDCARL: MODULATION LOW CARRIER CONTROL REGISTER

U-0	U-0	U-0	U-0	R/W-x/u	R/W-x/u	R/W-x/u	R/W-x/u
—	—	—	—	MDCLS<3:0> ⁽¹⁾			
bit 7				bit 0			

Legend:

R = Readable bit	W = Writable bit	U = Unimplemented bit, read as '0'
u = Bit is unchanged	x = Bit is unknown	-n/n = Value at POR and BOR/Value at all other Resets
'1' = Bit is set	'0' = Bit is cleared	

- bit 7-4 **Unimplemented:** Read as '0'
- bit 3-0 **MDCLS<3:0>** Modulator Data High Carrier Selection bits ⁽¹⁾
 - 1111 = LC4_out
 - 1110 = LC3_out
 - 1101 = LC2_out
 - 1100 = LC1_out
 - 1011 = NCO output
 - 1010 = PWM7_out
 - 1001 = PWM6_out
 - 1000 = CCP5 output (PWM Output mode only)
 - 0111 = CCP4 output (PWM Output mode only)
 - 0110 = CCP3 output (PWM Output mode only)
 - 0101 = CCP2 output (PWM Output mode only)
 - 0100 = CCP1 output (PWM Output mode only)
 - 0011 = Reference clock module signal (CLKR)
 - 0010 = HFINTOSC
 - 0001 = FOSC
 - 0000 = Pin selected by MDCARLPPS

Note 1: Narrowed carrier pulse widths or spurs may occur in the signal stream if the carrier is not synchronized.

PIC16(L)F18856/76

REGISTER 26-6: MDSRC: MODULATOR SOURCE REGISTER

U-0	U-0	U-0	R/W-x/u	R/W-x/u	R/W-x/u	R/W-x/u	R/W-x/u	
—	—	—	MDMS<4:0> ⁽¹⁾					
bit 7								bit 0

Legend:

R = Readable bit	W = Writable bit	U = Unimplemented bit, read as '0'
u = Bit is unchanged	x = Bit is unknown	-n/n = Value at POR and BOR/Value at all other Resets
'1' = Bit is set	'0' = Bit is cleared	

- bit 7-5 **Unimplemented:** Read as '0'
- bit 4-0 **MDMS<4:0>** Modulator Source Selection bits ⁽¹⁾
 - 11111-10100 = Reserved
 - 10011 = MSSP2_out
 - 10010 = MSSP1_out
 - 10001 = EUSART TX/CK output
 - 10000 = EUSART DT output
 - 01111 = LC4_out
 - 01110 = LC3_out
 - 01101 = LC2_out
 - 01100 = LC1_out
 - 01011 = C2OUT_sync
 - 01010 = C1OUT_sync
 - 01001 = NCO output
 - 01000 = PWM7_out
 - 00111 = PWM6_out
 - 00110 = CCP5 output (PWM Output mode only)
 - 00101 = CCP4 output (PWM Output mode only)
 - 00100 = CCP3 output (PWM Output mode only)
 - 00011 = CCP2 output (PWM Output mode only)
 - 00010 = CCP1 output (PWM Output mode only)
 - 00001 = MDBIT bit of MDCON0
 - 00000 = BIT selected by MDSRCPPS

Note 1: Narrowed carrier pulse widths or spurs may occur in the signal stream if the carrier is not synchronized.

PIC16(L)F18856/76

TABLE 26-1: SUMMARY OF REGISTERS ASSOCIATED WITH DATA SIGNAL MODULATOR MODE

Name	Bit 7	Bit 6	Bit 5	Bit 4	Bit 3	Bit 2	Bit 1	Bit 0	Register on Page
ANSELA	ANSA7	ANSA6	ANSA5	ANSA4	ANSA3	ANSA2	ANSA1	ANSA0	205
ANSELC	ANSC7	ANSC6	ANSC5	ANSC4	ANSC3	ANSC2	ANSC1	ANSC0	221
INLVLA	INLVLA7	INLVLA6	INLVLA5	INLVLA4	INLVLA3	INLVLA2	INLVLA1	INLVLA0	207
INLVLC	INLVLC7	INLVLC6	INLVLC5	INLVLC4	INLVLC3	INLVLC2	INLVLC1	INLVLC0	222
MDCON0	MDEN	—	MDOUT	MDOPOL	—	—	—	MDBIT	397
MDCON1	—	—	MDCHPOL	MDCHSYNC	—	—	MDCLPOL	MDCLSYNC	398
MDSRC	—	—	—	MDMS<4:0>					399
MDCARH	—	—	—	—	MDCHS<3:0>				400
MDCARL	—	—	—	—	MDCLS<3:0>				401
MDCARLPPS	—	—	—	MDCARLPPS<4:0>					249
MDCARHPPS	—	—	—	MDCARHPPS<4:0>					249
MDSRCPPS	—	—	—	MDSRCPPS<4:0>					249
RxyPPS	—	—	—	RxyPPS<4:0>					250
SLRCONA	SLRA7	SLRA6	SLRA5	SLRA4	SLRA3	SLRA2	SLRA1	SLRA0	207
SLRCONC	SLRC7	SLRC6	SLRC5	SLRC4	SLRC3	SLRC2	SLRC1	SLRC0	222
TRISA	TRISA7	TRISA6	TRISA5	TRISA4	TRISA3	TRISA2	TRISA1	TRISA0	204
TRISC	TRISC7	TRISC6	TRISC5	TRISC4	TRISC3	TRISC2	TRISC1	TRISC0	220

Legend: — = unimplemented, read as '0'. Shaded cells are not used in the Data Signal Modulator mode.

PIC16(L)F18856/76

27.0 TIMER0 MODULE

The Timer0 module is an 8/16-bit timer/counter with the following features:

- 16-bit timer/counter
- 8-bit timer/counter with programmable period
- Synchronous or asynchronous operation
- Selectable clock sources
- Programmable prescaler (independent of Watchdog Timer)
- Programmable postscaler
- Operation during Sleep mode
- Interrupt on match or overflow
- Output on I/O pin (via PPS) or to other peripherals

27.1 Timer0 Operation

Timer0 can operate as either an 8-bit timer/counter or a 16-bit timer/counter. The mode is selected with the T016BIT bit of the T0CON register.

When used with an internal clock source, the module is a timer and increments on every instruction cycle. When used with an external clock source, the module can be used as either a timer or a counter and increments on every rising edge of the external source.

27.1.1 16-BIT MODE

In normal operation, TMR0 increments on the rising edge of the clock source. A 15-bit prescaler on the clock input gives several prescale options (see prescaler control bits, T0CKPS<3:0> in the T0CON1 register).

27.1.1.1 Timer0 Reads and Writes in 16-Bit Mode

TMR0H is not the actual high byte of Timer0 in 16-bit mode. It is actually a buffered version of the real high byte of Timer0, which is neither directly readable nor writable (see [Figure 27-1](#)). TMR0H is updated with the contents of the high byte of Timer0 during a read of TMR0L. This provides the ability to read all 16 bits of Timer0 without having to verify that the read of the high and low byte was valid, due to a rollover between successive reads of the high and low byte.

Similarly, a write to the high byte of Timer0 must also take place through the TMR0H Buffer register. The high byte is updated with the contents of TMR0H when a write occurs to TMR0L. This allows all 16 bits of Timer0 to be updated at once.

27.1.2 8-BIT MODE

In normal operation, TMR0 increments on the rising edge of the clock source. A 15-bit prescaler on the clock input gives several prescale options (see prescaler control bits, T0CKPS<3:0> in the T0CON1 register).

The value of TMR0L is compared to that of the Period buffer, a copy of TMR0H, on each clock cycle. When the two values match, the following events happen:

- TMR0_out goes high for one prescaled clock period
- TMR0L is reset
- The contents of TMR0H are copied to the period buffer

In 8-bit mode, the TMR0L and TMR0H registers are both directly readable and writable. The TMR0L register is cleared on any device Reset, while the TMR0H register initializes at FFh.

Both the prescaler and postscaler counters are cleared on the following events:

- A write to the TMR0L register
- A write to either the T0CON0 or T0CON1 registers
- Any device Reset – Power-on Reset (POR), MCLR Reset, Watchdog Timer Reset (WDTR) or Brown-out Reset (BOR)

27.1.3 COUNTER MODE

In Counter mode, the prescaler is normally disabled by setting the T0CKPS bits of the T0CON1 register to '0000'. Each rising edge of the clock input (or the output of the prescaler if the prescaler is used) increments the counter by '1'.

27.1.4 TIMER MODE

In Timer mode, the Timer0 module will increment every instruction cycle as long as there is a valid clock signal and the T0CKPS bits of the T0CON1 register ([Register 27-2](#)) are set to '0000'. When a prescaler is added, the timer will increment at the rate based on the prescaler value.

27.1.5 ASYNCHRONOUS MODE

When the T0ASYNC bit of the T0CON1 register is set (T0ASYNC = '1'), the counter increments with each rising edge of the input source (or output of the prescaler, if used). Asynchronous mode allows the counter to continue operation during Sleep mode provided that the clock also continues to operate during Sleep.

27.1.6 SYNCHRONOUS MODE

When the T0ASYNC bit of the T0CON1 register is clear (T0ASYNC = 0), the counter clock is synchronized to the system oscillator (FOSC/4). When operating in Synchronous mode, the counter clock frequency cannot exceed FOSC/4.

27.2 Clock Source Selection

The T0CS<2:0> bits of the T0CON1 register are used to select the clock source for Timer0. [Register 27-2](#) displays the clock source selections.

PIC16(L)F18856/76

27.2.1 INTERNAL CLOCK SOURCE

When the internal clock source is selected, Timer0 operates as a timer and will increment on multiples of the clock source, as determined by the Timer0 prescaler.

27.2.2 EXTERNAL CLOCK SOURCE

When an external clock source is selected, Timer0 can operate as either a timer or a counter. Timer0 will increment on multiples of the rising edge of the external clock source, as determined by the Timer0 prescaler.

27.3 Programmable Prescaler

A software programmable prescaler is available for exclusive use with Timer0. There are 16 prescaler options for Timer0 ranging in powers of two from 1:1 to 1:32768. The prescaler values are selected using the T0CKPS<3:0> bits of the T0CON1 register.

The prescaler is not directly readable or writable. Clearing the prescaler register can be done by writing to the TMR0L register or the T0CON1 register.

27.4 Programmable Postscaler

A software programmable postscaler (output divider) is available for exclusive use with Timer0. There are 16 postscaler options for Timer0 ranging from 1:1 to 1:16. The postscaler values are selected using the T0OUTPS<3:0> bits of the T0CON0 register.

The postscaler is not directly readable or writable. Clearing the postscaler register can be done by writing to the TMR0L register or the T0CON0 register.

27.5 Operation during Sleep

When operating synchronously, Timer0 will halt. When operating asynchronously, Timer0 will continue to increment and wake the device from Sleep (if Timer0 interrupts are enabled) provided that the input clock source is active.

27.6 Timer0 Interrupts

The Timer0 interrupt flag bit (TMR0IF) is set when either of the following conditions occur:

- 8-bit TMR0L matches the TMR0H value
- 16-bit TMR0 rolls over from 'FFFFh'

When the postscaler bits (T0OUTPS<3:0>) are set to 1:1 operation (no division), the T0IF flag bit will be set with every TMR0 match or rollover. In general, the TMR0IF flag bit will be set every T0OUTPS + 1 matches or rollovers.

If Timer0 interrupts are enabled (TMR0IE bit of the PIE0 register = 1), the CPU will be interrupted and the device may wake from sleep (see [Section 27.2, Clock Source Selection](#) for more details).

27.7 Timer0 Output

The Timer0 output can be routed to any I/O pin via the RxyPPS output selection register (see [Section 13.0 “Peripheral Pin Select \(PPS\) Module”](#) for additional information). The Timer0 output can also be used by other peripherals, such as the Auto-conversion Trigger of the Analog-to-Digital Converter. Finally, the Timer0 output can be monitored through software via the Timer0 output bit (T0OUT) of the T0CON0 register ([Register 27-1](#)).

TMR0_out will be one postscaled clock period when a match occurs between TMR0L and TMR0H in 8-bit mode, or when TMR0 rolls over in 16-bit mode. The Timer0 output is a 50% duty cycle that toggles on each TMR0_out rising clock edge.

PIC16(L)F18856/76

FIGURE 27-1: BLOCK DIAGRAM OF TIMER0

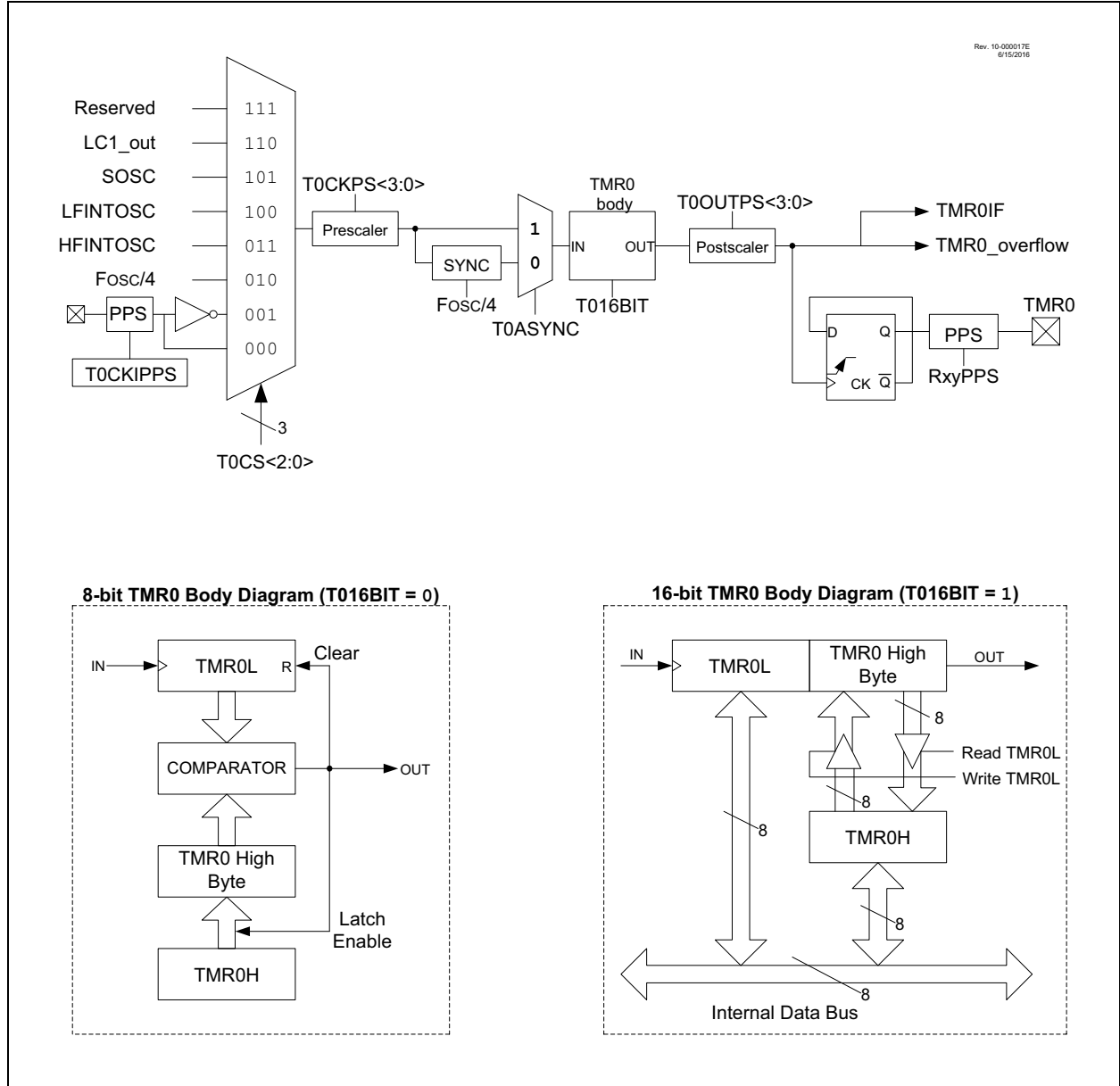

PIC16(L)F18856/76

REGISTER 27-1: T0CON0: TIMER0 CONTROL REGISTER 0

R/W-0/0	U-0	R-0	R/W-0/0	R/W-0/0	R/W-0/0	R/W-0/0	R/W-0/0
T0EN	—	T0OUT	T016BIT	T0OUTPS<3:0>			
bit 7							bit 0

Legend:

R = Readable bit	W = Writable bit	U = Unimplemented bit, read as '0'
u = Bit is unchanged	x = Bit is unknown	-n/n = Value at POR and BOR/Value at all other Resets
'1' = Bit is set	'0' = Bit is cleared	

bit 7	T0EN: TMR0 Enable bit 1 = The module is enabled and operating 0 = The module is disabled and in the lowest power mode
bit 6	Unimplemented: Read as '0'
bit 5	T0OUT: TMR0 Output bit (read-only) TMR0 output bit
bit 4	T016BIT: TMR0 Operating as 16-bit Timer Select bit 1 = TMR0 is a 16-bit timer 0 = TMR0 is an 8-bit timer
bit 3-0	T0OUTPS<3:0>: TMR0 output postscaler (divider) select bits 1111 = 1:16 Postscaler 1110 = 1:15 Postscaler 1101 = 1:14 Postscaler 1100 = 1:13 Postscaler 1011 = 1:12 Postscaler 1010 = 1:11 Postscaler 1001 = 1:10 Postscaler 1000 = 1:9 Postscaler 0111 = 1:8 Postscaler 0110 = 1:7 Postscaler 0101 = 1:6 Postscaler 0100 = 1:5 Postscaler 0011 = 1:4 Postscaler 0010 = 1:3 Postscaler 0001 = 1:2 Postscaler 0000 = 1:1 Postscaler

PIC16(L)F18856/76

REGISTER 27-2: T0CON1: TIMER0 CONTROL REGISTER 1

R/W-0/0	R/W-0/0	R/W-0/0	R/W-0/0	R/W-0/0	R/W-0/0	R/W-0/0	R/W-0/0
T0CS<2:0>		T0ASYNC	T0CKPS<3:0>				
bit 7							bit 0

Legend:

R = Readable bit	W = Writable bit	U = Unimplemented bit, read as '0'
u = Bit is unchanged	x = Bit is unknown	-n/n = Value at POR and BOR/Value at all other Resets
'1' = Bit is set	'0' = Bit is cleared	

bit 7-5 **T0CS<2:0>**: Timer0 Clock Source select bits

- 111 = Reserved
- 110 = LC1_out
- 101 = SOSC
- 100 = LFINTOSC
- 011 = HFINTOSC
- 010 = Fosc/4
- 001 = T0CKIPPS (Inverted)
- 000 = T0CKIPPS (True)

bit 4 **T0ASYNC**: TMR0 Input Asynchronization Enable bit

- 1 = The input to the TMR0 counter is not synchronized to system clocks
- 0 = The input to the TMR0 counter is synchronized to Fosc/4

bit 3-0 **T0CKPS<3:0>**: Prescaler Rate Select bit

- 1111 = 1:32768
- 1110 = 1:16384
- 1101 = 1:8192
- 1100 = 1:4096
- 1011 = 1:2048
- 1010 = 1:1024
- 1001 = 1:512
- 1000 = 1:256
- 0111 = 1:128
- 0110 = 1:64
- 0101 = 1:32
- 0100 = 1:16
- 0011 = 1:8
- 0010 = 1:4
- 0001 = 1:2
- 0000 = 1:1

PIC16(L)F18856/76

TABLE 27-1: SUMMARY OF REGISTERS ASSOCIATED WITH TIMER0

Name	Bit 7	Bit 6	Bit 5	Bit 4	Bit 3	Bit 2	Bit 1	Bit 0	Register on Page
TMR0L	Holding Register for the Least Significant Byte of the 16-bit TMR0 Register								404*
TMR0H	Holding Register for the Most Significant Byte of the 16-bit TMR0 Register								404*
T0CON0	T0EN	—	T0OUT	T016BIT	T0OUTPS<3:0>				407
T0CON1	T0CS<2:0>			T0ASYNC	T0CKPS<3:0>				408
T0CKIPPS	—	—	—	—	T0CKIPPS<3:0>				249
TMR0PPS	—	—	—	TMR0PPS<4:0>					249
ADACT	—	—	—	ADACT<4:0>					359
CLCxSELY	—	—	—	LCxDyS<4:0>					329
T1GCON	GE	GPOL	GTM	GSPM	GGO/DONE	GVAL	—	—	420
INTCON	GIE	PEIE	—	—	—	—	—	INTEDG	134
PIR0	—	—	TMR0IF	IOCIF	—	—	—	INTF	144
PIE0	—	—	TMR0IE	IOCIE	—	—	—	INTE	135

Legend: — = Unimplemented location, read as '0'. Shaded cells are not used by the Timer0 module.

* Page with Register information.

PIC16(L)F18856/76

28.0 TIMER1/3/5 MODULE WITH GATE CONTROL

The Timer1/3/5 modules are 16-bit timer/counters with the following features:

- 16-bit timer/counter register pair (TMR1H:TMR1L)
- Programmable internal or external clock source
- 2-bit prescaler
- Optionally synchronized comparator out
- Multiple Timer1 gate (count enable) sources
- Interrupt on overflow
- Wake-up on overflow (external clock, Asynchronous mode only)
- Time base for the Capture/Compare function
- Auto-conversion Trigger (with CCP)
- Selectable Gate Source Polarity
- Gate Toggle mode
- Gate Single-Pulse mode
- Gate Value Status
- Gate Event Interrupt

[Figure 28-1](#) is a block diagram of the Timer1 module.

This device has three instances of Timer1 type modules. They include:

- Timer1
- Timer3
- Timer5

All references to Timer1 and Timer1 Gate apply equally to Timer3 and Timer5.

PIC16(L)F18856/76

FIGURE 28-1: TIMER1 BLOCK DIAGRAM

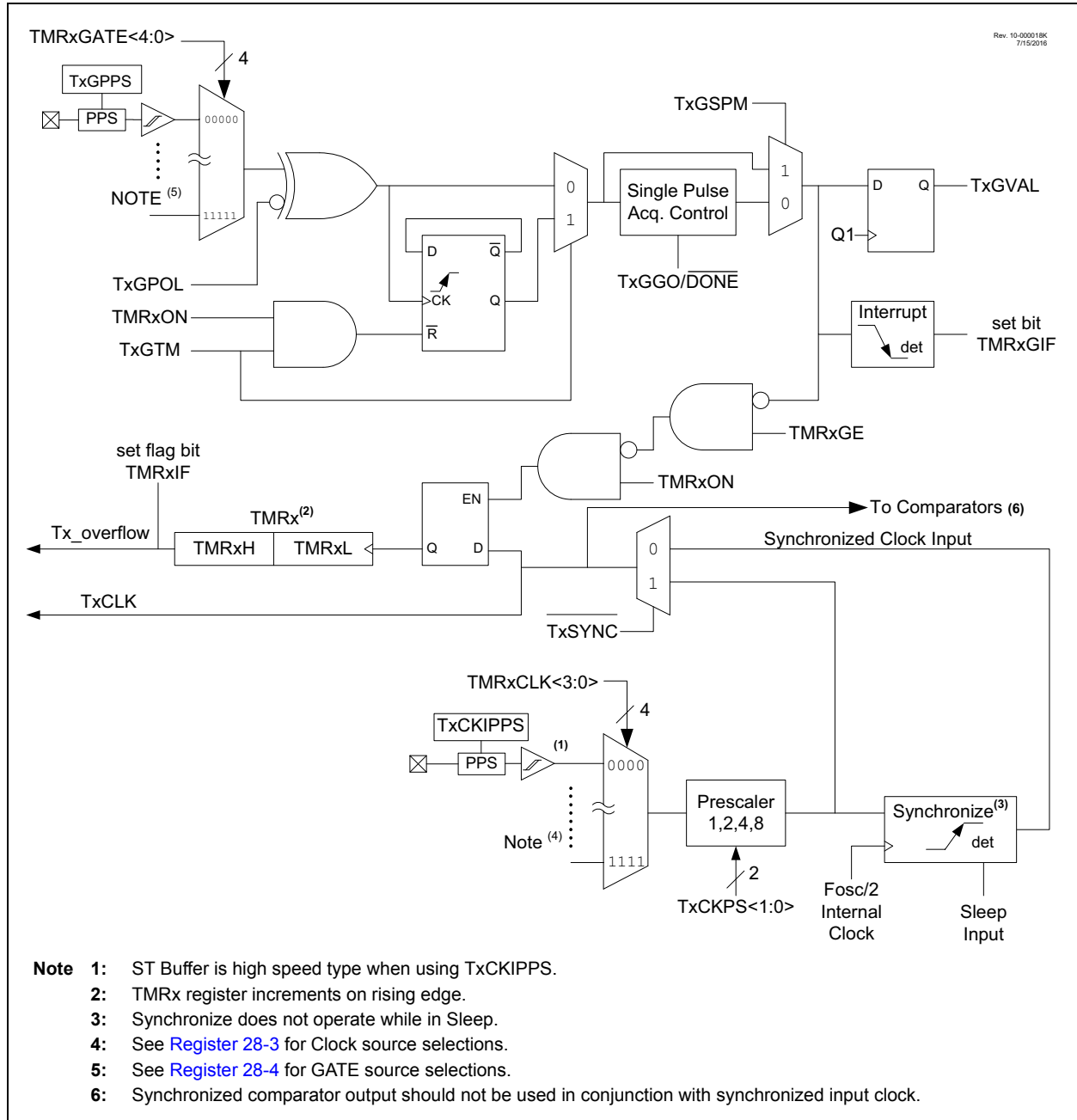

PIC16(L)F18856/76

28.1 Timer1 Operation

The Timer1 modules are 16-bit incrementing counters which are accessed through the TMR1H:TMR1L register pairs. Writes to TMR1H or TMR1L directly update the counter.

When used with an internal clock source, the module is a timer and increments on every instruction cycle. When used with an external clock source, the module can be used as either a timer or counter and increments on every selected edge of the external source.

The timer is enabled by configuring the TMR1ON and GE bits in the T1CON and T1GCON registers, respectively. [Table 28-1](#) displays the Timer1 enable selections.

TABLE 28-1: TIMER1 ENABLE SELECTIONS

TMR1ON	TMR1GE	Timer1 Operation
1	1	Count Enabled
1	0	Always On
0	1	Off
0	0	Off

28.2 Clock Source Selection

The T1CLK register is used to select the clock source for the timer. [Register 28-3](#) shows the possible clock sources that may be selected to make the timer increment.

28.2.1 INTERNAL CLOCK SOURCE

When the internal clock source FOSC is selected, the TMR1H:TMR1L register pair will increment on multiples of FOSC as determined by the respective Timer1 prescaler.

When the FOSC internal clock source is selected, the timer register value will increment by four counts every instruction clock cycle. Due to this condition, a 2 LSB error in resolution will occur when reading the TMR1H:TMR1L value. To utilize the full resolution of the timer in this mode, an asynchronous input signal must be used to gate the timer clock input.

Out of the total timer gate signal sources, the following subset of sources can be asynchronous and may be useful for this purpose:

- CLC4 output
- CLC3 output
- CLC2 output
- CLC1 output
- Zero-Cross Detect output
- Comparator2 output
- Comparator1 output
- TxG PPS remappable input pin

28.2.2 EXTERNAL CLOCK SOURCE

When the timer is enabled and the external clock input source (ex: T1CKI PPS remappable input) is selected as the clock source, the timer will increment on the rising edge of the external clock input.

When using an external clock source, the timer can be configured to run synchronously or asynchronously, as described in [Section 28.6 “Timer Operation in Asynchronous Counter Mode”](#).

When used as a timer with a clock oscillator, an external 32.768 kHz crystal can be used connected to the SOSCI/SOSCO pins.

Note: In Counter mode, a falling edge must be registered by the counter prior to the first incrementing rising edge after any one or more of the following conditions:

- The timer is first enabled after POR
- Firmware writes to TMR1H or TMR1L
- The timer is disabled
- The timer is re-enabled (e.g., TMR1ON-->1) when the T1CKI signal is currently logic low.

28.3 Timer Prescaler

Timer1 has four prescaler options allowing 1, 2, 4 or 8 divisions of the clock input. The CKPS bits of the T1CON register control the prescale counter. The prescale counter is not directly readable or writable; however, the prescaler counter is cleared upon a write to TMR1H or TMR1L.

28.4 Timer1 16-Bit Read/Write Mode

Timer1 can be configured for 16-bit reads and writes. When the RD16 control bit (T1CON<1>) is set, the address for TMR1H is mapped to a buffer register for the high byte of Timer1. A read from TMR1L loads the contents of the high byte of Timer1 into the Timer1 High Byte Buffer register. This provides the user with the ability to accurately read all 16 bits of Timer1 without having to determine whether a read of the high byte, followed by a read of the low byte, has become invalid due to a rollover between reads. A write to the high byte of Timer1 must also take place through the TMR1H Buffer register. The Timer1 high byte is updated with the contents of TMR1H when a write occurs to TMR1L. This allows a user to write all 16 bits at once to both the high and low bytes of Timer1. The high byte of Timer1 is not directly readable or writable in this mode. All reads and writes must take place through the Timer1 High Byte Buffer register. Writes to TMR1H do not clear the Timer1 prescaler. The prescaler is only cleared on writes to TMR1L.

PIC16(L)F18856/76

28.5 Secondary Oscillator

A dedicated low-power 32.768 kHz oscillator circuit is built-in between pins SOSC1 (input) and SOSCO (amplifier output). This internal circuit is designed to be used in conjunction with an external 32.768 kHz crystal.

The oscillator circuit is enabled by setting the SOSCE bit of the OSCEN register. The oscillator will continue to run during Sleep.

Note: The oscillator requires a start-up and stabilization time before use. Thus, SOSCE should be set and a suitable delay observed prior to using Timer1 with the SOSC source. A suitable delay similar to the OST delay can be implemented in software by clearing the TMR1IF bit then presetting the TMR1H:TMR1L register pair to FC00h. The TMR1IF flag will be set when 1024 clock cycles have elapsed, thereby indicating that the oscillator is running and reasonably stable.

28.6 Timer Operation in Asynchronous Counter Mode

If the control bit $\overline{\text{SYNC}}$ of the T1CON register is set, the external clock input is not synchronized. The timer increments asynchronously to the internal phase clocks. If the external clock source is selected then the timer will continue to run during Sleep and can generate an interrupt on overflow, which will wake-up the processor. However, special precautions in software are needed to read/write the timer (see [Section 28.6.1 “Reading and Writing Timer1 in Asynchronous Counter Mode”](#)).

Note: When switching from synchronous to asynchronous operation, it is possible to skip an increment. When switching from asynchronous to synchronous operation, it is possible to produce an additional increment.

28.6.1 READING AND WRITING TIMER1 IN ASYNCHRONOUS COUNTER MODE

Reading TMR1H or TMR1L while the timer is running from an external asynchronous clock will ensure a valid read (taken care of in hardware). However, the user should keep in mind that reading the 16-bit timer in two 8-bit values itself, poses certain problems, since the timer may overflow between the reads.

For writes, it is recommended that the user simply stop the timer and write the desired values. A write contention may occur by writing to the timer registers, while the register is incrementing. This may produce an unpredictable value in the TMR1H:TMR1L register pair.

28.7 Timer Gate

Timer1 can be configured to count freely or the count can be enabled and disabled using the time gate circuitry. This is also referred to as Timer Gate Enable.

The timer gate can also be driven by multiple selectable sources.

28.7.1 TIMER GATE ENABLE

The Timer Gate Enable mode is enabled by setting the GE bit of the T1GCON register. The polarity of the Timer Gate Enable mode is configured using the GPOL bit of the T1GCON register.

When Timer Gate Enable mode is enabled, the timer will increment on the rising edge of the Timer1 clock source. When Timer Gate Enable mode is disabled, no incrementing will occur and the timer will hold the current count. See [Figure 28-3](#) for timing details.

TABLE 28-2: TIMER GATE ENABLE SELECTIONS

T1CLK	T1GPOL	T1G	Timer Operation
↑	1	1	Counts
↑	1	0	Holds Count
↑	0	1	Holds Count
↑	0	0	Counts

PIC16(L)F18856/76

28.7.2 TIMER GATE SOURCE SELECTION

One of the several different external or internal signal sources may be chosen to gate the timer and allow the timer to increment. The gate input signal source can be selected based on the T1GATE register setting. See the T1GATE register ([Register 28-4](#)) description for a complete list of the available gate sources. The polarity for each available source is also selectable. Polarity selection is controlled by the GPOL bit of the T1GCON register.

28.7.2.1 T1G Pin Gate Operation

The T1G pin is one source for the timer gate control. It can be used to supply an external source to the time gate circuitry.

28.7.2.2 Timer0 Overflow Gate Operation

When Timer0 overflows, or a period register match condition occurs (in 8-bit mode), a low-to-high pulse will automatically be generated and internally supplied to the Timer1 gate circuitry.

28.7.2.3 Comparator C1 Gate Operation

The output resulting from a Comparator 1 operation can be selected as a source for the timer gate control. The Comparator 1 output can be synchronized to the timer clock or left asynchronous. For more information see [Section 18.4.1](#) “[Comparator Output Synchronization](#)”.

28.7.2.4 Comparator C2 Gate Operation

The output resulting from a Comparator 2 operation can be selected as a source for the timer gate control. The Comparator 2 output can be synchronized to the timer clock or left asynchronous. For more information see [Section 18.4.1](#) “[Comparator Output Synchronization](#)”.

28.7.3 TIMER1 GATE TOGGLE MODE

When Timer1 Gate Toggle mode is enabled, it is possible to measure the full-cycle length of a timer gate signal, as opposed to the duration of a single level pulse.

The timer gate source is routed through a flip-flop that changes state on every incrementing edge of the signal. See [Figure 28-4](#) for timing details.

Timer1 Gate Toggle mode is enabled by setting the GTM bit of the T1GCON register. When the GTM bit is cleared, the flip-flop is cleared and held clear. This is necessary in order to control which edge is measured.

Note: Enabling Toggle mode at the same time as changing the gate polarity may result in indeterminate operation.

28.7.4 TIMER1 GATE SINGLE-PULSE MODE

When Timer1 Gate Single-Pulse mode is enabled, it is possible to capture a single-pulse gate event. Timer1 Gate Single-Pulse mode is first enabled by setting the GSPM bit in the T1GCON register. Next, the GGO/DONE bit in the T1GCON register must be set. The timer will be fully enabled on the next incrementing edge. On the next trailing edge of the pulse, the GGO/DONE bit will automatically be cleared. No other gate events will be allowed to increment the timer until the GGO/DONE bit is once again set in software. See [Figure 28-5](#) for timing details.

If the Single-Pulse Gate mode is disabled by clearing the GSPM bit in the T1GCON register, the GGO/DONE bit should also be cleared.

Enabling the Toggle mode and the Single-Pulse mode simultaneously will permit both sections to work together. This allows the cycle times on the timer gate source to be measured. See [Figure 28-6](#) for timing details.

28.7.5 TIMER1 GATE VALUE STATUS

When Timer1 Gate Value Status is utilized, it is possible to read the most current level of the gate control value. The value is stored in the GVAL bit in the T1GCON register. The GVAL bit is valid even when the timer gate is not enabled (GE bit is cleared).

28.7.6 TIMER1 GATE EVENT INTERRUPT

When Timer1 Gate Event Interrupt is enabled, it is possible to generate an interrupt upon the completion of a gate event. When the falling edge of T1GVAL occurs, the TMR1GIF flag bit in the PIR5 register will be set. If the TMR1GIE bit in the PIE5 register is set, then an interrupt will be recognized.

The TMR1GIF flag bit operates even when the timer gate is not enabled (TMR1GE bit is cleared).

PIC16(L)F18856/76

28.8 Timer1 Interrupts

The timer register pair (TMR1H:TMR1L) increments to FFFFh and rolls over to 0000h. When the timer rolls over, the respective timer interrupt flag bit of the PIR5 register is set. To enable the interrupt on rollover, you must set these bits:

- ON bit of the T1CON register
- TMR1IE bit of the PIE4 register
- PEIE bit of the INTCON register
- GIE bit of the INTCON register

The interrupt is cleared by clearing the TMR1IF bit in the Interrupt Service Routine.

Note: To avoid immediate interrupt vectoring, the TMR1H:TMR1L register pair should be preloaded with a value that is not imminently about to rollover, and the TMR1IF flag should be cleared prior to enabling the timer interrupts.

28.9 Timer1 Operation During Sleep

Timer1 can only operate during Sleep when setup in Asynchronous Counter mode. In this mode, an external crystal or clock source can be used to increment the counter. To set up the timer to wake the device:

- ON bit of the T1CON register must be set
- TMR1IE bit of the PIE4 register must be set
- PEIE bit of the INTCON register must be set
- $\overline{\text{SYNC}}$ bit of the T1CON register must be set
- CLK bits of the T1CLK register must be configured
- The timer clock source must be enabled and continue operation during sleep. When the SOSC is used for this purpose, the SOSSEN bit of the OSCEN register must be set.

The device will wake-up on an overflow and execute the next instructions. If the GIE bit of the INTCON register is set, the device will call the Interrupt Service Routine.

Secondary oscillator will continue to operate in Sleep regardless of the $\overline{\text{SYNC}}$ bit setting.

28.10 CCP Capture/Compare Time Base

The CCP modules use the TMR1H:TMR1L register pair as the time base when operating in Capture or Compare mode.

In Capture mode, the value in the TMR1H:TMR1L register pair is copied into the CCPRxH:CCPRxL register pair on a configured event.

In Compare mode, an event is triggered when the value CCPRxH:CCPRxL register pair matches the value in the TMR1H:TMR1L register pair. This event can be an Auto-conversion Trigger.

The Timer1 to CCP1/2/3/4/5 mapping is not fixed, and can be assigned on an individual CCP module basis. All of the CCP modules may be configured to share a single Timer1 (or Timer3, or Timer5) resource, or different CCP modules may be configured to use different Timer1 resources. This timer to CCP mapping selection is made in the CCPTMRS0 and CCPTMRS1 registers.

For more information, see [Section 30.0 “Capture/Compare/PWM Modules”](#).

28.11 CCP Auto-Conversion Trigger

When any of the CCP's are configured to trigger an auto-conversion, the trigger will clear the TMR1H:TMR1L register pair. This auto-conversion does not cause a timer interrupt. The CCP module may still be configured to generate a CCP interrupt.

In this mode of operation, the CCPRxH:CCPRxL register pair becomes the period register for Timer1.

The timer should be synchronized and FOSC/4 should be selected as the clock source in order to utilize the Auto-conversion Trigger. Asynchronous operation of the timer can cause an Auto-conversion Trigger to be missed.

In the event that a write to TMR1H or TMR1L coincides with an Auto-conversion Trigger from the CCP, the write will take precedence.

For more information, see [Section 30.2.4 “Compare During Sleep”](#).

PIC16(L)F18856/76

FIGURE 28-2: TIMER1 INCREMENTING EDGE

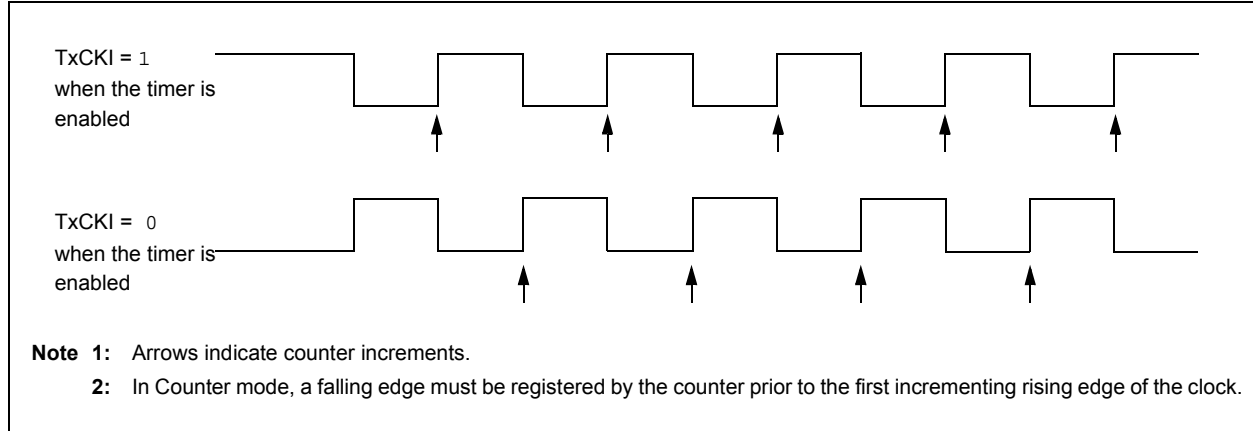
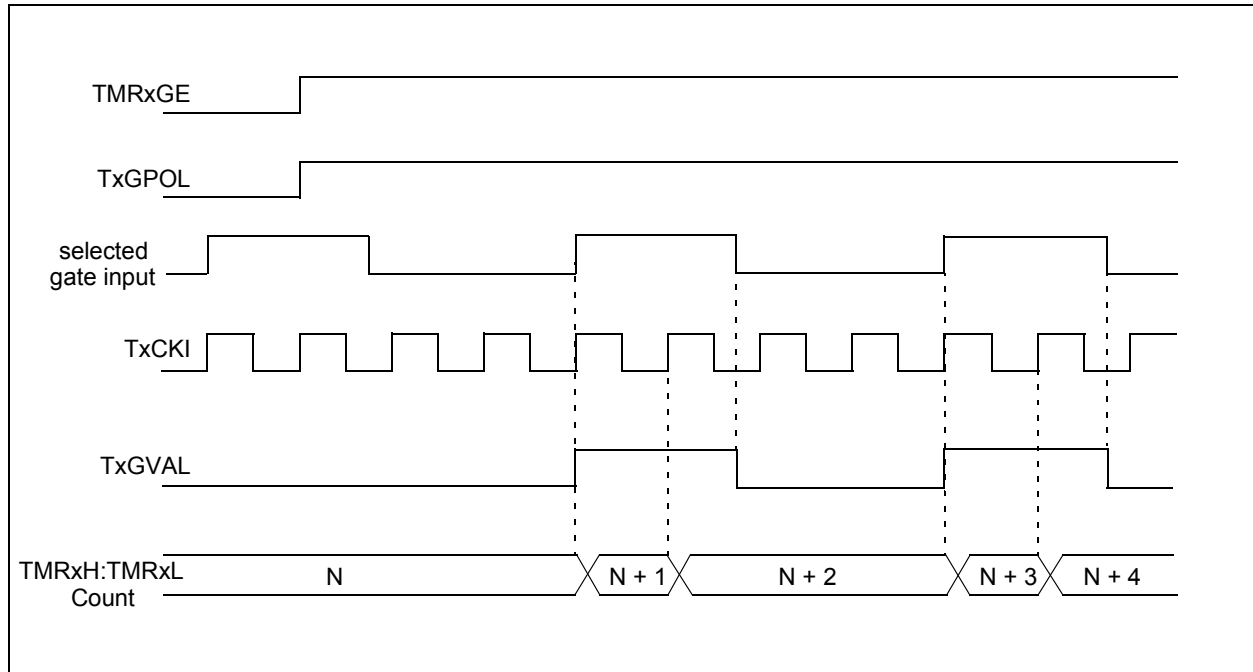

FIGURE 28-3: TIMER1 GATE ENABLE MODE



PIC16(L)F18856/76

FIGURE 28-4: TIMER1 GATE TOGGLE MODE

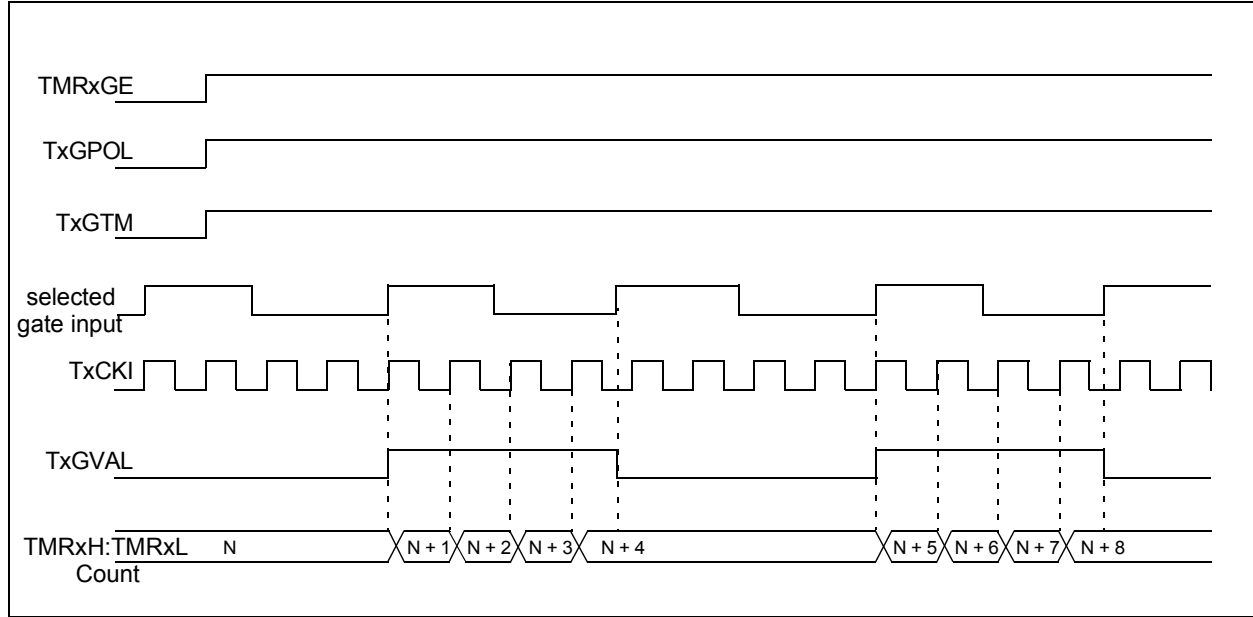
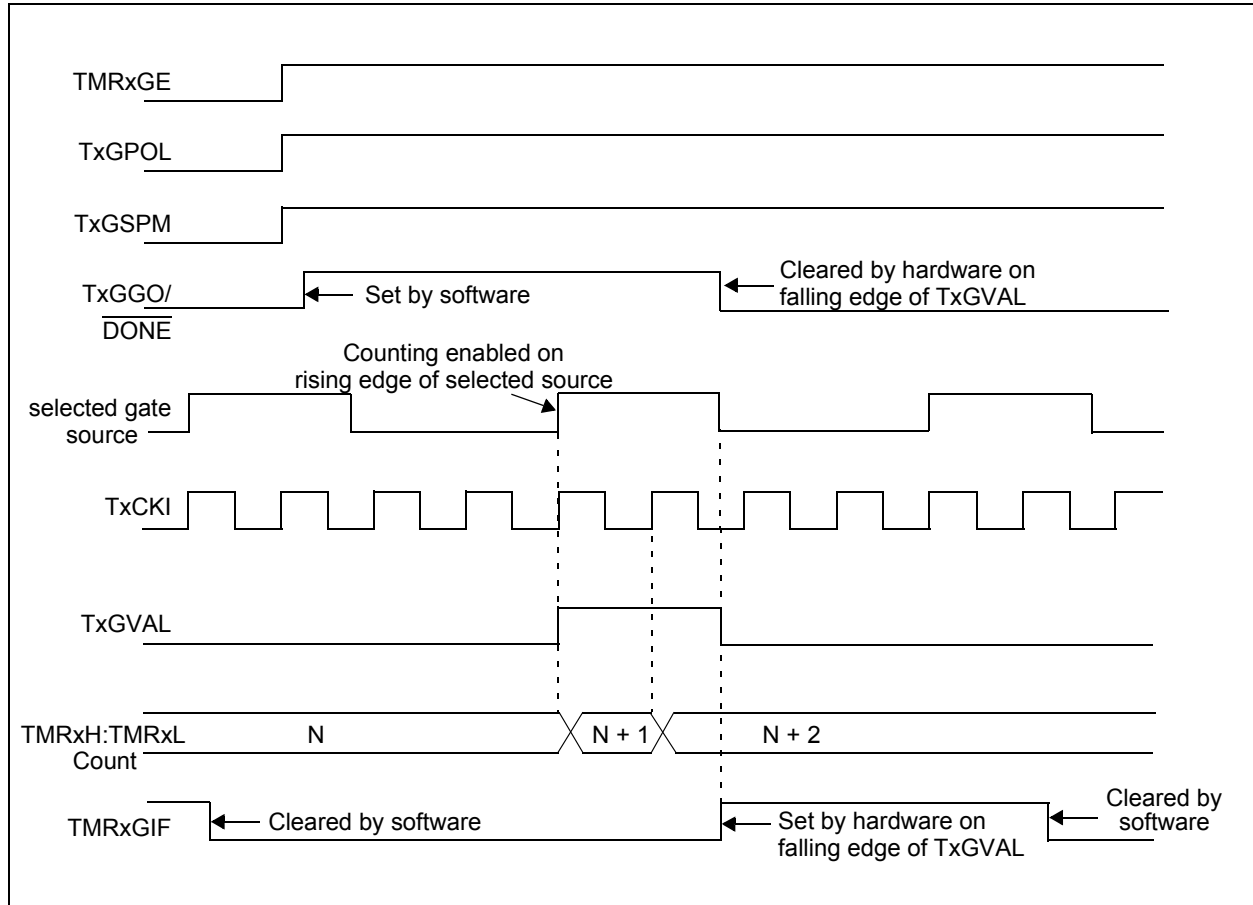
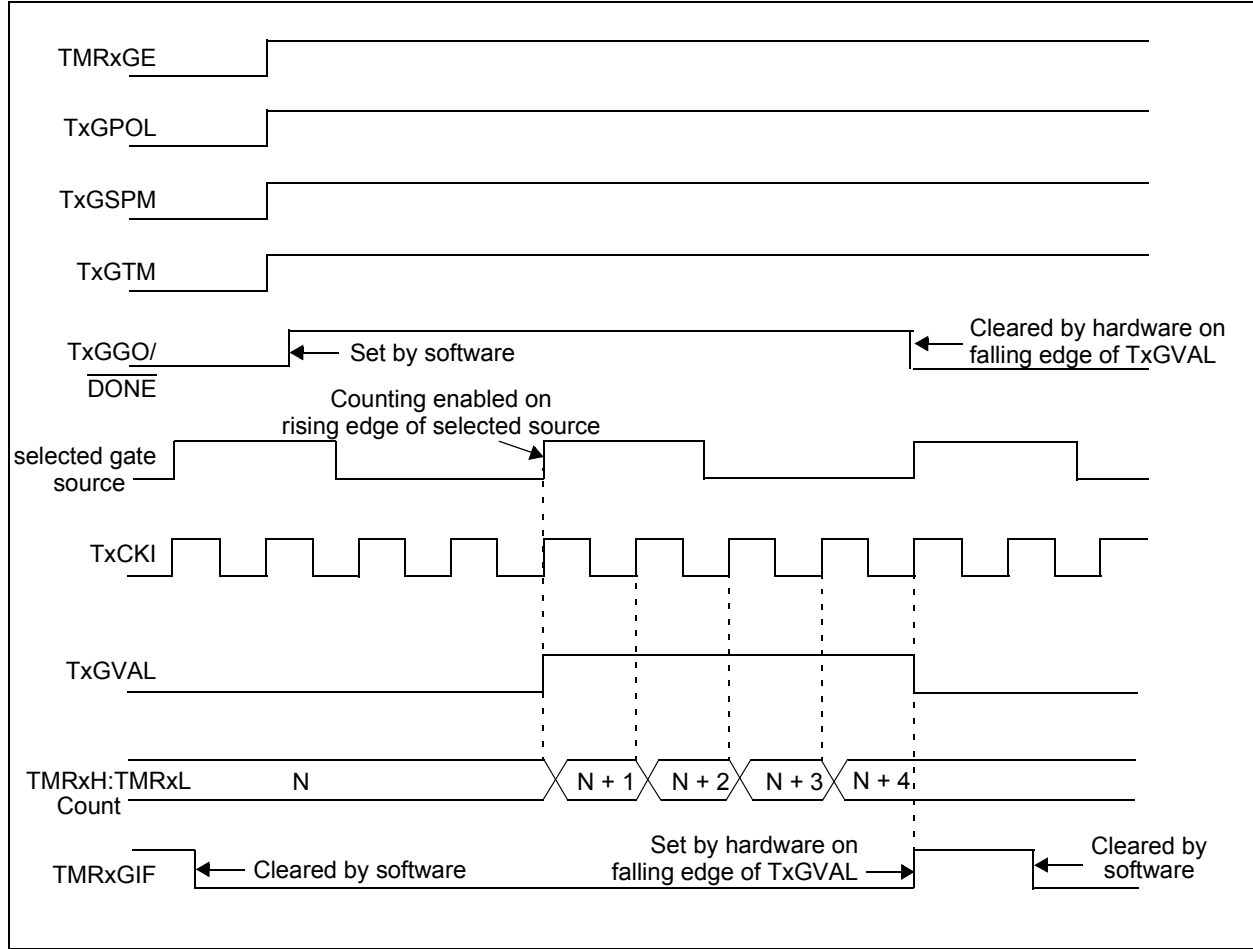

FIGURE 28-5: TIMER1 GATE SINGLE-PULSE MODE



PIC16(L)F1856/76

FIGURE 28-6: TIMER1 GATE SINGLE-PULSE AND TOGGLE COMBINED MODE



PIC16(L)F18856/76

28.12 Register Definitions: Timer1 Control start here with Memory chapter compare

Long bit name prefixes for the Timer1/3/5 are shown in Table 28-3. Refer to Section 1.1 “Register and Bit naming conventions” for more information

TABLE 28-3:

Peripheral	Bit Name Prefix
Timer1	T1
Timer3	T3
Timer5	T5

REGISTER 28-1: TxCON: TIMER1/3/5 CONTROL REGISTER

U-0	U-0	R/W-0/u	R/W-0/u	U-0	R/W-0/u	R/W-0/u	R/W-0/u
—	—	CKPS<1:0>		—	$\overline{\text{SYNC}}$	RD16	ON
bit 7							bit 0

Legend:

R = Readable bit	W = Writable bit	U = Unimplemented bit, read as '0'
u = Bit is unchanged	x = Bit is unknown	-n/n = Value at POR and BOR/Value at all other Resets
'1' = Bit is set	'0' = Bit is cleared	

bit 7-6 **Unimplemented:** Read as '0'

bit 5-4 **CKPS<1:0>:** Timer1 Input Clock Prescale Select bits

11 = 1:8 Prescale value
 10 = 1:4 Prescale value
 01 = 1:2 Prescale value
 00 = 1:1 Prescale value

bit 3 **Unimplemented:** Read as '0'

bit 2 **SYNC:** Timer1 Synchronization Control bit

When TMR1CLK = Fosc or Fosc/4

This bit is ignored. The timer uses the internal clock and no additional synchronization is performed.

When TMR1CS<1:0> = (any setting other than Fosc or Fosc/4)

1 = Do not synchronize external clock input
 0 = Synchronized external clock input with system clock

bit 1 **RD16:** Timer1 On bit

1 = All 16 bits of Timer1 can be read simultaneously (TMR1H is buffered)
 0 = 16-bit reads of Timer1 are disabled (TMR1H is not buffered)

bit 0 **ON:** Timer1 On bit

1 = Enables Timer1
 0 = Stops Timer1 and clears Timer1 gate flip-flop

PIC16(L)F18856/76

REGISTER 28-2: TxGCON: TIMER1/3/5 GATE CONTROL REGISTER

R/W-0/u	R/W-0/u	R/W-0/u	R/W-0/u	R/W/HC-0/u	R-x/x	U-0	U-0
GE	GPOL	GTM	GSPM	<u>GGO/</u> DONE	GVAL	—	—
bit 7						bit 0	

Legend:

R = Readable bit	W = Writable bit	U = Unimplemented bit, read as '0'
u = Bit is unchanged	x = Bit is unknown	-n/n = Value at POR and BOR/Value at all other Resets
'1' = Bit is set	'0' = Bit is cleared	HC = Bit is cleared by hardware

- bit 7 **GE:** Timer1 Gate Enable bit
If ON = 0:
This bit is ignored
If ON = 1:
1 = Timer1 counting is controlled by the Timer1 gate function
0 = Timer1 is always counting
- bit 6 **GPOL:** Timer1 Gate Polarity bit
1 = Timer1 gate is active-high (Timer1 counts when gate is high)
0 = Timer1 gate is active-low (Timer1 counts when gate is low)
- bit 5 **GTM:** Timer1 Gate Toggle Mode bit
1 = Timer1 Gate Toggle mode is enabled
0 = Timer1 Gate Toggle mode is disabled and toggle flip-flop is cleared
Timer1 gate flip-flop toggles on every rising edge.
- bit 4 **GSPM:** Timer1 Gate Single-Pulse Mode bit
1 = Timer1 Gate Single-Pulse mode is enabled and is controlling Timer1 gate
0 = Timer1 Gate Single-Pulse mode is disabled
- bit 3 **GGO/DONE:** Timer1 Gate Single-Pulse Acquisition Status bit
1 = Timer1 gate single-pulse acquisition is ready, waiting for an edge
0 = Timer1 gate single-pulse acquisition has completed or has not been started
This bit is automatically cleared when GSPM is cleared
- bit 2 **GVAL:** Timer1 Gate Value Status bit
Indicates the current state of the Timer1 gate that could be provided to TMR1H:TMR1L
Unaffected by Timer1 Gate Enable (GE)
- bit 1-0 **Unimplemented:** Read as '0'

PIC16(L)F18856/76

REGISTER 28-3: TxCLK TIMER1/3/5 CLOCK SELECT REGISTER

U-0	U-0	U-0	U-0	R/W-0/u	R/W-0/u	R/W-0/u	R/W-0/u
—	—	—	—	CS<3:0>			
bit 7				bit 0			

Legend:

R = Readable bit

W = Writable bit

U = Unimplemented bit, read as '0'

u = Bit is unchanged

x = Bit is unknown

-n/n = Value at POR and BOR/Value at all other Resets

'1' = Bit is set

'0' = Bit is cleared

bit 7-4

Unimplemented: Read as '0'

bit 3-0

TxCS<3:0>: Timer1/3/5 Clock Select bits

1111 = LC4_out

1110 = LC3_out

1101 = LC2_out

1100 = LC1_out

1011 = TMR5 overflow output⁽³⁾

1010 = TMR3 overflow output⁽²⁾

1001 = TMR1 overflow output⁽¹⁾

1000 = TMR0 overflow output

0111 = CLKR output clock

0110 = SOSC

0101 = MFINTOSC

0100 = LFINTOSC

0011 = HFINTOSC

0010 = Fosc

0001 = Fosc/4

0000 = TxCKIPPS

Note 1: For Timer1, this bit is Reserved.

2: For Timer3, this bit is Reserved.

3: For Timer5, this bit is Reserved.

PIC16(L)F18856/76

REGISTER 28-4: TxGATE TIMER1/3/5 GATE SELECT REGISTER

U-0	U-0	U-0	R/W-0/u	R/W-0/u	R/W-0/u	R/W-0/u	R/W-0/u
—	—	—	GSS<4:0>				
bit 7							bit 0

Legend:

R = Readable bit	W = Writable bit	U = Unimplemented bit, read as '0'
u = Bit is unchanged	x = Bit is unknown	-n/n = Value at POR and BOR/Value at all other Resets
'1' = Bit is set	'0' = Bit is cleared	

bit 7-5 **Unimplemented:** Read as '0'

bit 4-0 **GSS<4:0>:** Timer1 Gate Select bits

11111 = Reserved

•

•

•

11001 = Reserved

11000 = LC4_out

10111 = LC3_out

10110 = LC2_out

10101 = LC1_out

10100 = ZCD1_output

10011 = C2OUT_sync

10010 = C1OUT_sync

10001 = DDS_out

10000 = PWM7_out

01111 = PWM6_out

01110 = CCP5_out

01101 = CCP4_out

01100 = CCP3_out

01011 = CCP2_out

01010 = CCP1_out

01001 = SMT2_match

01000 = SMT1_match

00111 = TMR6_postscaled

00110 = TMR5 overflow output⁽³⁾

00101 = TMR4_postscaled

00100 = TMR3 overflow output⁽²⁾

00011 = TMR2_postscaled

00010 = TMR1 overflow output⁽¹⁾

00001 = TMR0 overflow output

00000 = T1GPPS

- Note 1:** For Timer1, this bit is Reserved.
- 2:** For Timer3, this bit is Reserved.
- 3:** For Timer5, this bit is Reserved.

PIC16(L)F18856/76

TABLE 28-4: SUMMARY OF REGISTERS ASSOCIATED WITH TIMER1

Name	Bit 7	Bit 6	Bit 5	Bit 4	Bit 3	Bit 2	Bit 1	Bit 0	Register on Page
INTCON	GIE	PEIE	—	—	—	—	—	INTEDG	134
PIR1	OSFIF	CSWIF	—	—	—	—	ADTIF	ADIF	134
PIE1	OSFIE	CSWIE	—	—	—	—	ADTIE	ADIE	136
T1CON	—	—	CKPS<5:4>		—	SYNC	RD16	ON	419
T1GCON	GE	GPOL	GTM	GSPM	GGO/ DONE	GVAL	—	—	420
T1GATE	—	—	—	GSS<4:0>					422
T1CLK	—	—	—	—	CS<3:0>				421
TMR1L	Holding Register for the Least Significant Byte of the 16-bit TMR1 Register								410*
TMR1H	Holding Register for the Most Significant Byte of the 16-bit TMR1 Register								410*
T1CKIPPS	—	—	—	T1CKIPPS<4:0>					249
T1GPPS	—	—	—	T1GPPS<4:0>					249
T3CON	—	—	CKPS<5:4>		—	SYNC	RD16	ON	419
T3GCON	GE	GPOL	GTM	GSPM	GGO/ DONE	GVAL	—	—	420
T3GATE	—	—	—	GSS<4:0>					422
T3CLK	—	—	—	—	CS<3:0>				421
TMR3L	Holding Register for the Least Significant Byte of the 16-bit TMR3 Register								410*
TMR3H	Holding Register for the Most Significant Byte of the 16-bit TMR3 Register								410*
T3CKIPPS	—	—	—	T3CKIPPS<4:0>					249
T3GPPS	—	—	—	T3GPPS<4:0>					249
T5CON	—	—	CKPS<5:4>		—	SYNC	RD16	ON	419
T5GCON	GE	GPOL	GTM	GSPM	GGO/ DONE	GVAL	—	—	420
T5GATE	—	—	—	GSS<4:0>					422
T5CLK	—	—	—	—	CS<3:0>				421
TMR5L	Holding Register for the Least Significant Byte of the 16-bit TMR5 Register								410*
TMR5H	Holding Register for the Most Significant Byte of the 16-bit TMR5 Register								410*
T5CKIPPS	—	—	—	T5CKIPPS<4:0>					249
T5GPPS	—	—	—	T5GPPS<4:0>					249
T0CON0	T0EN	—	T0OUT	T016BIT	T0OUTPS<3:0>				407
CMxCON0	CxON	CxOUT	—	CxPOL	—	CxSP	CxHYS	CxSYNC	279
CCPTMRS0	C4TSEL<1:0>		C3TSEL<1:0>		C2TSEL<1:0>		C1TSEL<1:0>		455
CCPTMRS1	—	—	P7TSEL<1:0>		P6TSEL<1:0>		C5TSEL<1:0>		455
CCPxCON	CCPxEN	—	CCPxOUT	CCPxFMT	CCPxMODE<3:0>				452
CLCxSELY	—	—	—	LCxDyS<4:0>					329
ADACT	—	—	—	ADACT<4:0>					359

Legend: — = Unimplemented location, read as '0'. Shaded cells are not used with the Timer1 modules.

* Page with register information.

PIC16(L)F18856/76

29.0 TIMER2/4/6 MODULE

The Timer2/4/6 modules are 8-bit timers that can operate as free-running period counters or in conjunction with external signals that control start, run, freeze, and reset operation in One-Shot and Monostable modes of operation. Sophisticated waveform control such as pulse density modulation are possible by combining the operation of these timers with other internal peripherals such as the comparators and CCP modules. Features of the timer include:

- 8-bit timer register
- 8-bit period register
- Selectable external hardware timer Resets
- Programmable prescaler (1:1 to 1:128)
- Programmable postscaler (1:1 to 1:16)
- Selectable synchronous/asynchronous operation
- Alternate clock sources
- Interrupt-on-period

- Three modes of operation:
 - Free Running Period
 - One-shot
 - Monostable

See [Figure 29-1](#) for a block diagram of Timer2. See [Figure 29-2](#) for the clock source block diagram.

Note: Three identical Timer2 modules are implemented on this device. The timers are named Timer2, Timer4, and Timer6. All references to Timer2 apply as well to Timer4 and Timer6. All references to T2PR apply as well to T4PR and T6PR.

FIGURE 29-1: TIMER2 BLOCK DIAGRAM

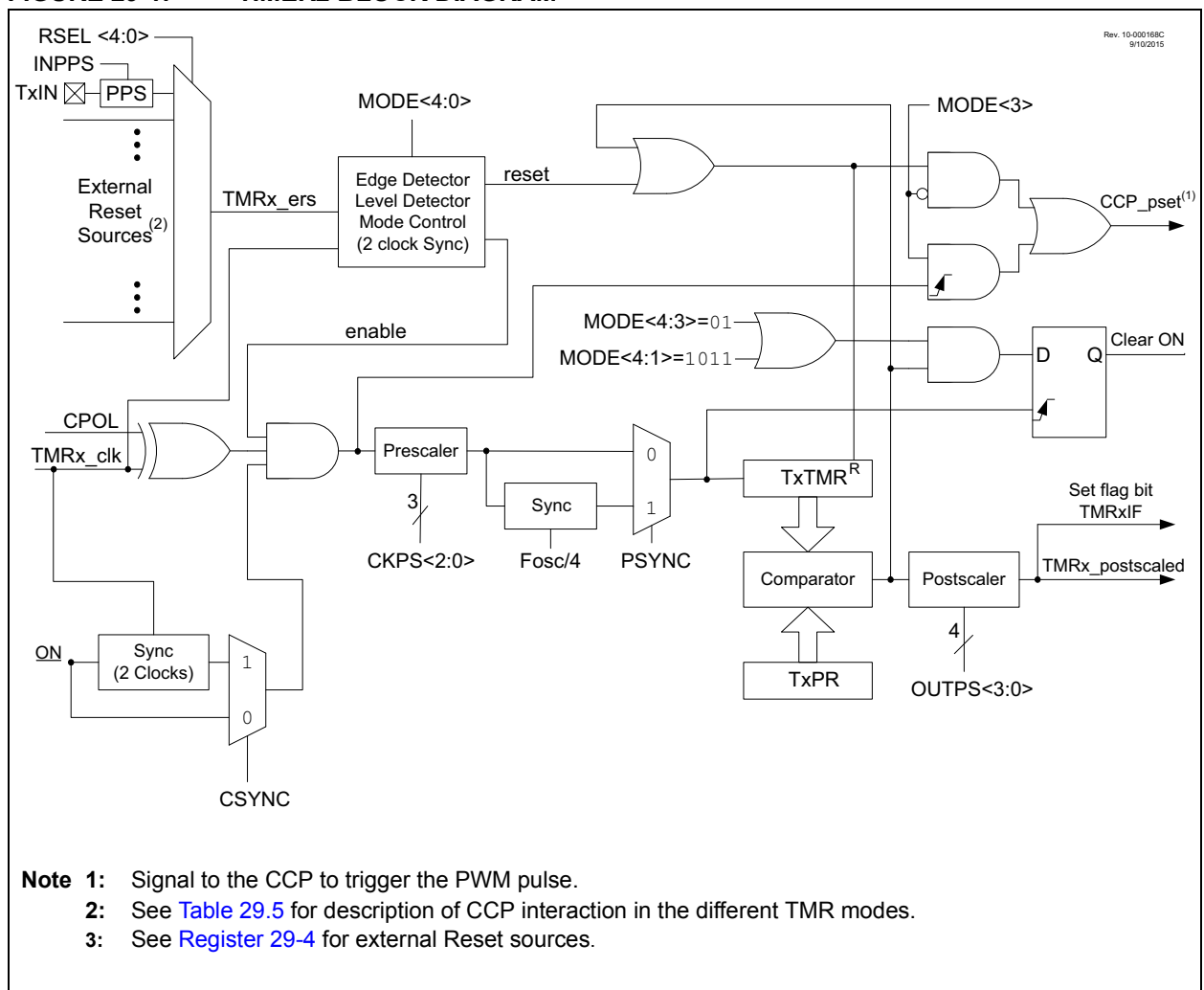

PIC16(L)F18856/76

FIGURE 29-2: TIMER2 CLOCK SOURCE BLOCK DIAGRAM

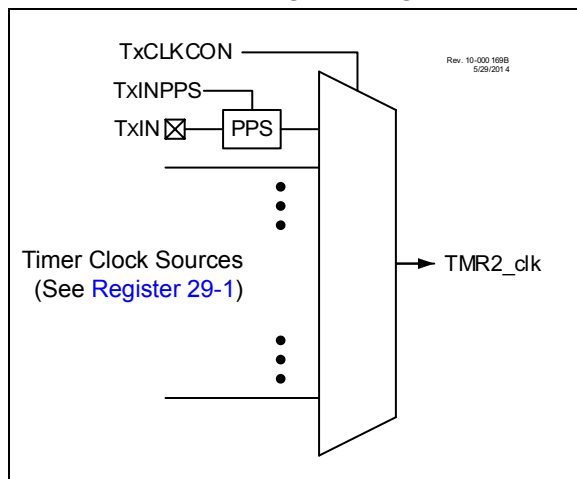

29.1 Timer2 Operation

Timer2 operates in three major modes:

- Free Running Period
- One-shot
- Monostable

Within each mode there are several options for starting, stopping, and reset. [Table 29-1](#) lists the options.

In all modes, the TMR2 count register is incremented on the rising edge of the clock signal from the programmable prescaler. When TMR2 equals T2PR, a high level is output to the postscaler counter. TMR2 is cleared on the next clock input.

An external signal from hardware can also be configured to gate the timer operation or force a TMR2 count Reset. In Gate modes the counter stops when the gate is disabled and resumes when the gate is enabled. In Reset modes the TMR2 count is reset on either the level or edge from the external source.

The TMR2 and T2PR registers are both directly readable and writable. The TMR2 register is cleared and the T2PR register initializes to FFh on any device Reset. Both the prescaler and postscaler counters are cleared on the following events:

- a write to the TMR2 register
- a write to the T2CON register
- a write to the T2HLT register
- any device Reset
- External Reset Source event that resets the timer.

Note: TMR2 is not cleared when T2CON is written.

29.1.1 FREE RUNNING PERIOD MODE

The value of TMR2 is compared to that of the Period register, T2PR, on each clock cycle. When the two values match, the comparator resets the value of TMR2 to 00h on the next cycle and increments the output postscaler counter. When the postscaler count equals the value in the OUTPS<4:0> bits of the TMRxCON1 register then a one clock period wide pulse occurs on the TMR2_postscaled output, and the postscaler count is cleared.

29.1.2 ONE-SHOT MODE

The One-Shot mode is identical to the Free Running Period mode except that the ON bit is cleared and the timer is stopped when TMR2 matches T2PR and will not restart until the T2ON bit is cycled off and on. Postscaler OUTPS<4:0> values other than 0 are meaningless in this mode because the timer is stopped at the first period event and the postscaler is reset when the timer is restarted.

29.1.3 MONOSTABLE MODE

Monostable modes are similar to One-Shot modes except that the ON bit is not cleared and the timer can be restarted by an external Reset event.

29.2 Timer2 Output

The Timer2 module's primary output is TMR2_postscaled, which pulses for a single TMR2_clk period when the postscaler counter matches the value in the OUTPS bits of the TMR2CON register. The T2PR postscaler is incremented each time the TMR2 value matches the T2PR value. This signal can be selected as an input to several other input modules:

- The ADC module, as an Auto-conversion Trigger
- CWG, as an auto-shutdown source
- Memory Scanner, as a trigger to begin a scan
- Timer 1/3/5, as a gate input
- Timer 2/4/6, as an external reset signal
- SMT, as both a window and signal input

In addition, the Timer2 is also used by the CCP module for pulse generation in PWM mode. Both the actual TMR2 value as well as other internal signals are sent to the CCP module to properly clock both the period and pulse width of the PWM signal. See [Section 30.0 "Capture/Compare/PWM Modules"](#) for more details on setting up Timer2 for use with the CCP, as well as the timing diagrams in [Section 29.5 "Operation Examples"](#) for examples of how the varying Timer2 modes affect CCP PWM output.

29.3 External Reset Sources

In addition to the clock source, the Timer2 also takes in an external Reset source. This external Reset source is selected for Timer2, Timer4, and Timer6 with the T2RST, T4RST, and T6RST registers, respectively. This source can control starting and stopping of the timer, as well as resetting the timer, depending on which mode the timer is in. The mode of the timer is controlled by the MODE<4:0> bits of the TMRxHLT register. Edge-Triggered modes require six Timer clock periods between external triggers. Level-Triggered modes require the triggering level to be at least three Timer clock periods long. External triggers are ignored while in Debug Freeze mode.

PIC16(L)F18856/76

TABLE 29-1: TIMER2 OPERATING MODES

Mode	MODE<4:0>		Output Operation	Operation	Timer Control			
	<4:3>	<2:0>			Start	Reset	Stop	
Free Running Period	00	000	Period Pulse	Software gate (Figure 29-4)	ON = 1	—	ON = 0	
		001		Hardware gate, active-high (Figure 29-5)	ON = 1 and TMRx_ers = 1	—	ON = 0 or TMRx_ers = 0	
		010		Hardware gate, active-low	ON = 1 and TMRx_ers = 0	—	ON = 0 or TMRx_ers = 1	
		011	Period Pulse with Hardware Reset	Rising or falling edge Reset	ON = 1	TMRx_ers ↓	ON = 0	
		100		Rising edge Reset (Figure 29-6)		TMRx_ers ↑		
		101		Falling edge Reset		TMRx_ers ↓		
		110		Low level Reset		TMRx_ers = 0	ON = 0 or TMRx_ers = 0	
		111		High level Reset (Figure 29-7)		TMRx_ers = 1	ON = 0 or TMRx_ers = 1	
One-shot	01	000	One-shot	Software start (Figure 29-8)	ON = 1	—	ON = 0 or Next clock after TMRx = PRx (Note 2)	
		001	Edge triggered start (Note 1)	Rising edge start (Figure 29-9)	ON = 1 and TMRx_ers ↑	—		
		010		Falling edge start	ON = 1 and TMRx_ers ↓	—		
		011		Any edge start	ON = 1 and TMRx_ers ↓	—		
		100	Edge triggered start and hardware Reset (Note 1)	Rising edge start and Rising edge Reset (Figure 29-10)	ON = 1 and TMRx_ers ↑	TMRx_ers ↑		
		101		Falling edge start and Falling edge Reset	ON = 1 and TMRx_ers ↓	TMRx_ers ↓		
		110		Rising edge start and Low level Reset (Figure 29-11)	ON = 1 and TMRx_ers ↑	TMRx_ers = 0		
		111		Falling edge start and High level Reset	ON = 1 and TMRx_ers ↓	TMRx_ers = 1		
Mono-stable	10	000	Reserved					
		001	Edge triggered start (Note 1)	Rising edge start (Figure 29-12)	ON = 1 and TMRx_ers ↑	—	ON = 0 or Next clock after TMRx = PRx (Note 3)	
		010		Falling edge start	ON = 1 and TMRx_ers ↓	—		
		011		Any edge start	ON = 1 and TMRx_ers ↓	—		
		Reserved	100	Reserved				
		Reserved	101	Reserved				
		One-shot	11	110	Level triggered start and hardware Reset	High level start and Low level Reset (Figure 29-13)	ON = 1 and TMRx_ers = 1	TMRx_ers = 0
111	Low level start & High level Reset			ON = 1 and TMRx_ers = 0		TMRx_ers = 1		
Reserved	11	xxx	Reserved					

- Note 1:** If ON = 0 then an edge is required to restart the timer after ON = 1.
Note 2: When TMRx = PRx then the next clock clears ON and stops TMRx at 00h.
Note 3: When TMRx = PRx then the next clock stops TMRx at 00h but does not clear ON.

PIC16(L)F18856/76

29.4 Timer2 Interrupt

Timer2 can also generate a device interrupt. The interrupt is generated when the postscaler counter matches one of 16 postscale options (from 1:1 through 1:16), which are selected with the postscaler control bits, OUTPS<3:0> of the T2CON register. The interrupt is enabled by setting the TMR2IE interrupt enable bit of the PIE4 register. Interrupt timing is illustrated in Figure 29-3.

FIGURE 29-3: TIMER2 PRESCALER, POSTSCALER, AND INTERRUPT TIMING DIAGRAM

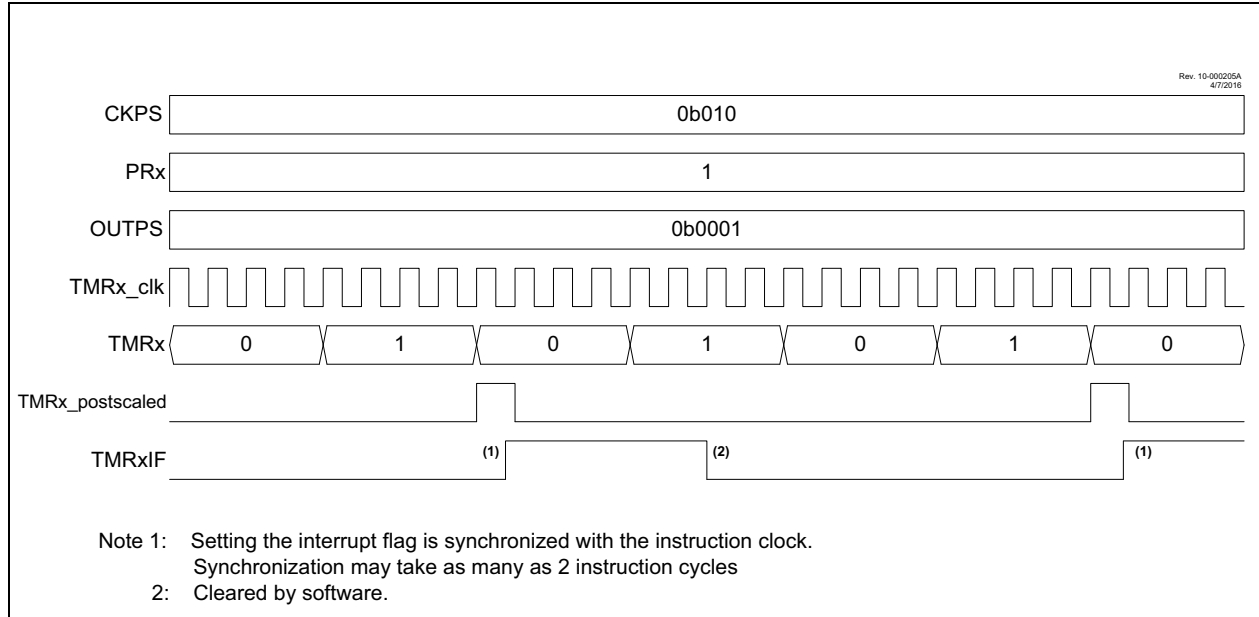

PIC16(L)F18856/76

29.5 Operation Examples

Unless otherwise specified, the following notes apply to the following timing diagrams:

- Both the prescaler and postscaler are set to 1:1 (both the CKPS and OUTPS bits in the TxCON register are cleared).
- The diagrams illustrate any clock except $F_{osc}/4$ and show clock-sync delays of at least two full cycles for both ON and Timer2_ers. When using $F_{osc}/4$, the clock-sync delay is at least one instruction period for Timer2_ers; ON applies in the next instruction period.
- The PWM Duty Cycle and PWM output are illustrated assuming that the timer is used for the PWM function of the CCP module as described in [Section 30.0 “Capture/Compare/PWM Modules”](#). The signals are not a part of the Timer2 module.

29.5.1 SOFTWARE GATE MODE

This mode corresponds to legacy Timer2 operation. The timer increments with each clock input when $ON = 1$ and does not increment when $ON = 0$. When the TMRx count equals the PRx period count the timer resets on the next clock and continues counting from 0. Operation with the ON bit software controlled is illustrated in [Figure 29-4](#). With $PRx = 5$, the counter advances until $TMRx = 5$, and goes to zero with the next clock.

FIGURE 29-4: SOFTWARE GATE MODE TIMING DIAGRAM (MODE = 00000)

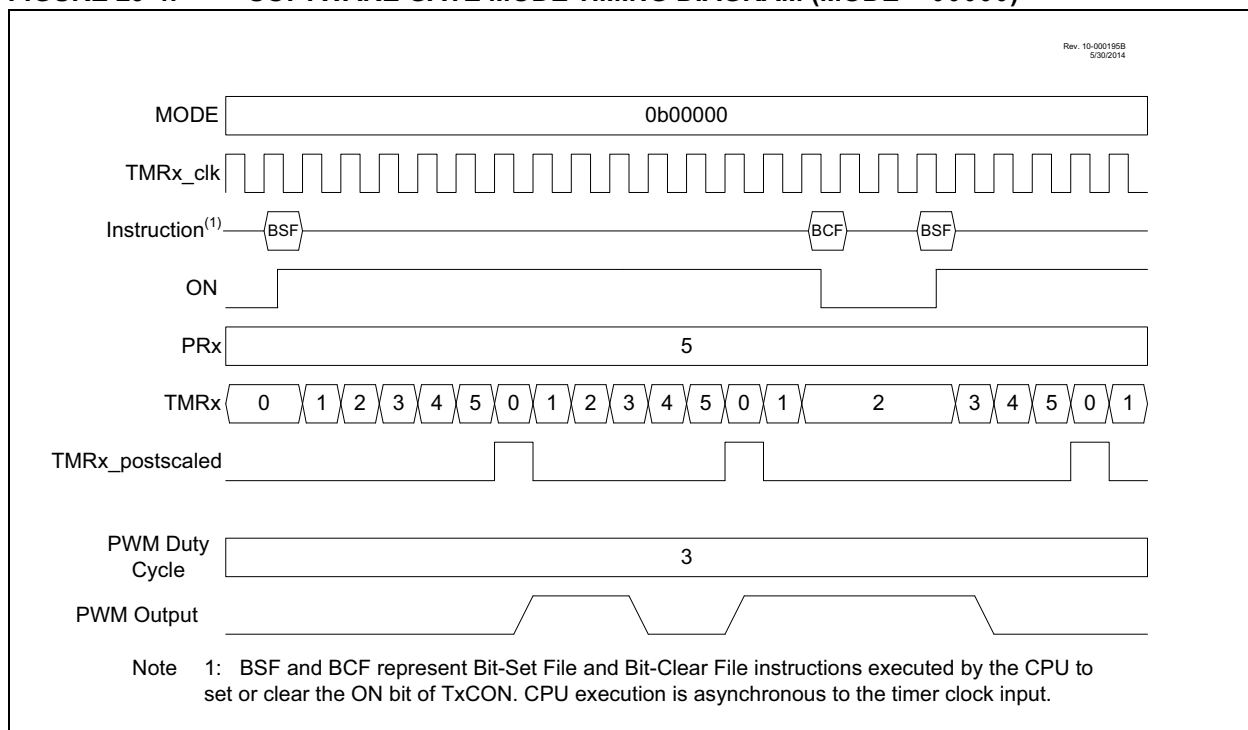

PIC16(L)F18856/76

29.5.2 HARDWARE GATE MODE

The Hardware Gate modes operate the same as the Software Gate mode except the TMRx_ers external signal can also gate the timer. When used with the CCP the gating extends the PWM period. If the timer is stopped when the PWM output is high then the duty cycle is also extended.

When MODE<4:0> = 00001 then the timer is stopped when the external signal is high. When MODE<4:0> = 00010 then the timer is stopped when the external signal is low.

Figure 29-5 illustrates the Hardware Gating mode for MODE<4:0> = 00001 in which a high input level starts the counter.

FIGURE 29-5: HARDWARE GATE MODE TIMING DIAGRAM (MODE = 00001)

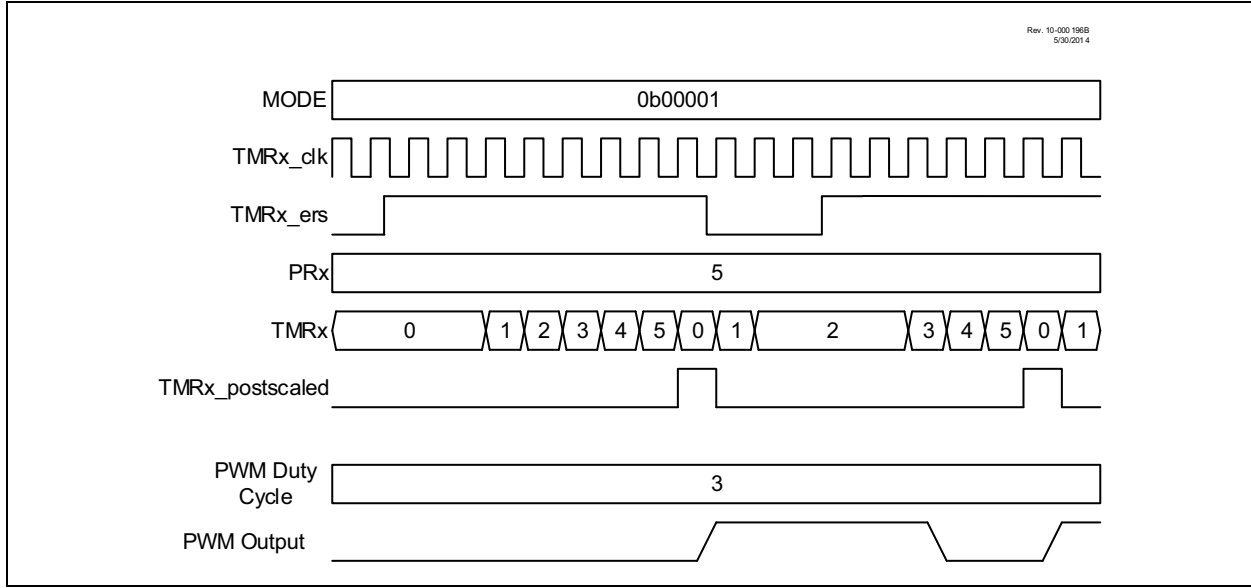

PIC16(L)F18856/76

29.5.3 EDGE-TRIGGERED HARDWARE LIMIT MODE

In Hardware Limit mode the timer can be reset by the TMRx_ers external signal before the timer reaches the period count. Three types of Resets are possible:

- Reset on rising or falling edge (MODE<4:0> = 00011)
(MODE<4:0> = 00011)
- Reset on rising edge (MODE<4:0> = 00100)
- Reset on falling edge (MODE<4:0> = 00101)

When the timer is used in conjunction with the CCP in PWM mode then an early Reset shortens the period and restarts the PWM pulse after a two clock delay. Refer to [Figure 29-6](#).

FIGURE 29-6: EDGE-TRIGGERED HARDWARE LIMIT MODE TIMING DIAGRAM (MODE = 00100)

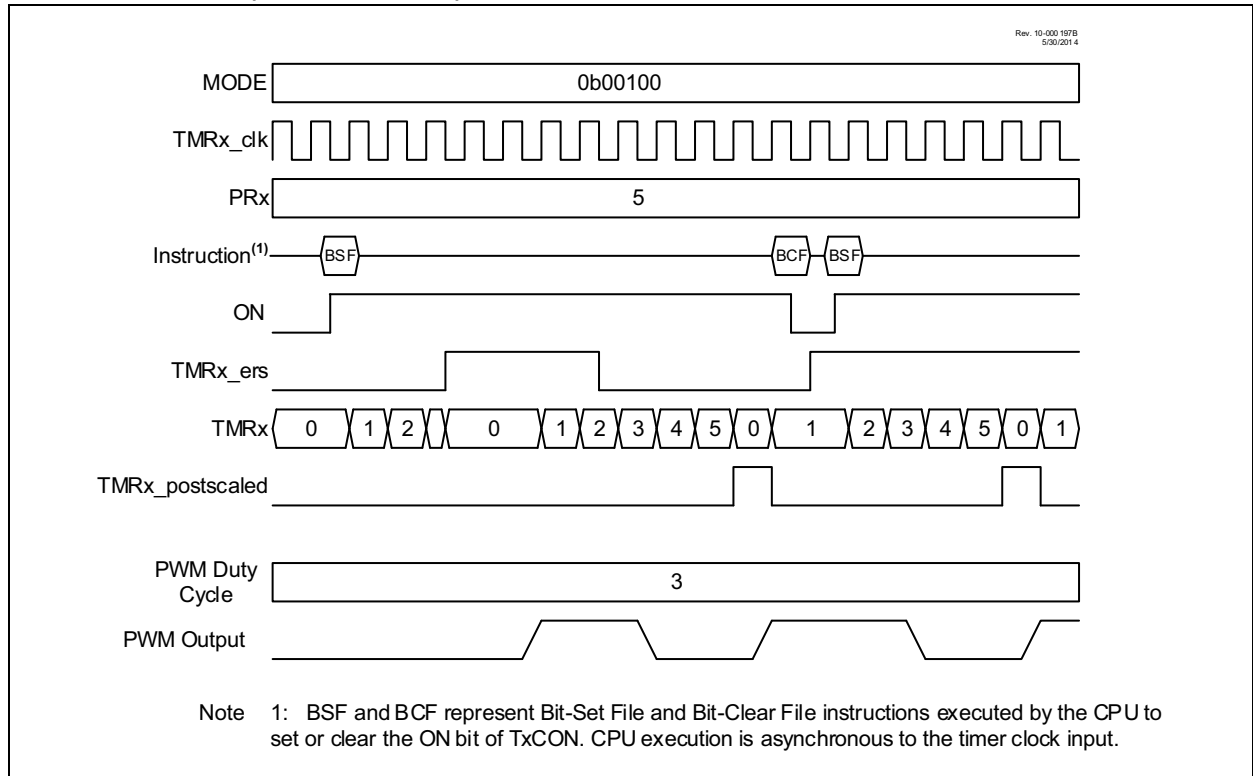

PIC16(L)F18856/76

29.5.4 LEVEL-TRIGGERED HARDWARE LIMIT MODE

In the Level-Triggered Hardware Limit Timer modes the counter is reset by high or low levels of the external signal TMRx_ers, as shown in Figure 29-7. Selecting MODE<4:0> = 00110 will cause the timer to reset on a low level external signal. Selecting MODE<4:0> = 00111 will cause the timer to reset on a high level external signal. In the example, the counter is reset while TMRx_ers = 1. ON is controlled by BSF and BCF instructions. When ON = 0 the external signal is ignored.

When the CCP uses the timer as the PWM time base then the PWM output will be set high when the timer starts counting and then set low only when the timer count matches the CCPRx value. The timer is reset when either the timer count matches the PRx value or two clock periods after the external Reset signal goes true and stays true.

The timer starts counting, and the PWM output is set high, on either the clock following the PRx match or two clocks after the external Reset signal relinquishes the Reset. The PWM output will remain high until the timer counts up to match the CCPRx pulse width value. If the external Reset signal goes true while the PWM output is high then the PWM output will remain high until the Reset signal is released allowing the timer to count up to match the CCPRx value.

FIGURE 29-7: LEVEL-TRIGGERED HARDWARE LIMIT MODE TIMING DIAGRAM (MODE = 00111)

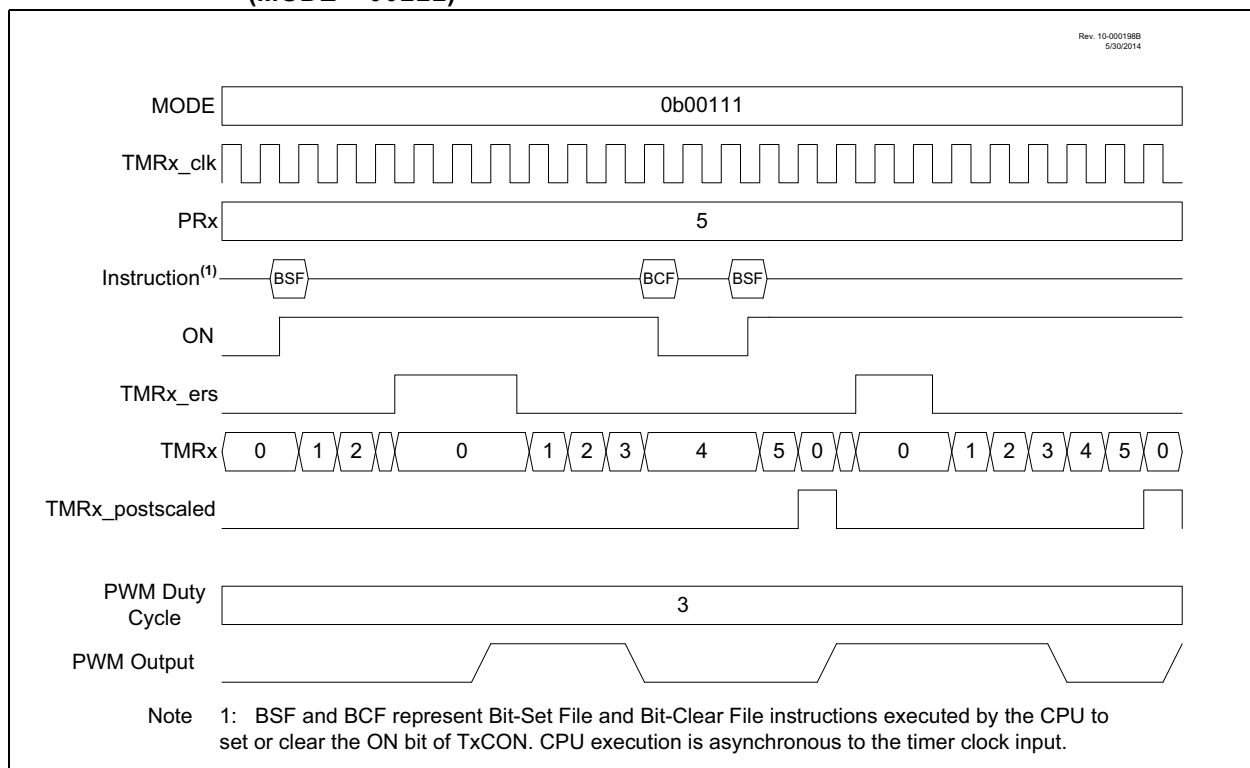

PIC16(L)F18856/76

29.5.5 SOFTWARE START ONE-SHOT MODE

In One-Shot mode the timer resets and the ON bit is cleared when the timer value matches the PRx period value. The ON bit must be set by software to start another timer cycle. Setting MODE<4:0> = 01000 selects One-Shot mode which is illustrated in Figure 29-8. In the example, ON is controlled by BSF and BCF instructions. In the first case, a BSF instruction sets ON and the counter runs to completion and clears ON. In the second case, a BSF instruction starts the cycle, BCF/BSF instructions turn the counter off and on during the cycle, and then it runs to completion.

When One-Shot mode is used in conjunction with the CCP PWM operation the PWM pulse drive starts concurrent with setting the ON bit. Clearing the ON bit while the PWM drive is active will extend the PWM drive. The PWM drive will terminate when the timer value matches the CCPRx pulse width value. The PWM drive will remain off until software sets the ON bit to start another cycle. If software clears the ON bit after the CCPRx match but before the PRx match then the PWM drive will be extended by the length of time the ON bit remains cleared. Another timing cycle can only be initiated by setting the ON bit after it has been cleared by a PRx period count match.

FIGURE 29-8: SOFTWARE START ONE-SHOT MODE TIMING DIAGRAM (MODE = 01000)

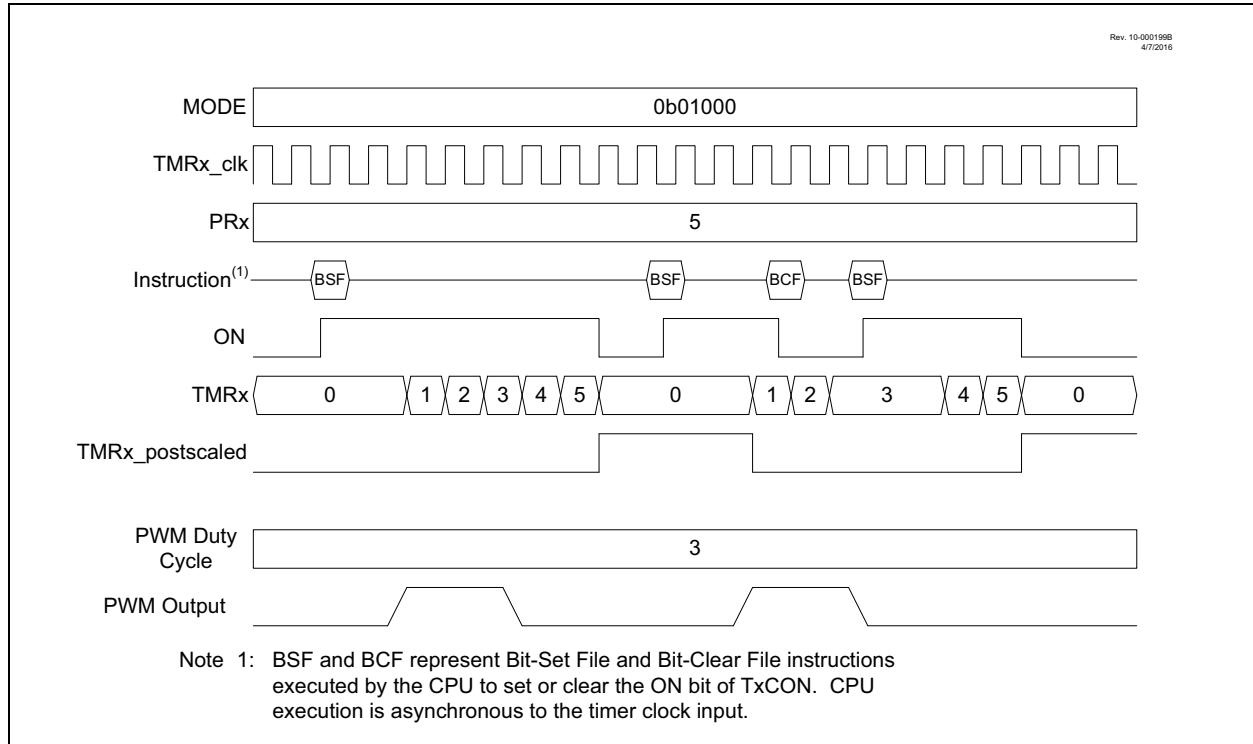

PIC16(L)F18856/76

29.5.6 EDGE-TRIGGERED ONE-SHOT MODE

The Edge-Triggered One-Shot modes start the timer on an edge from the external signal input, after the ON bit is set, and clear the ON bit when the timer matches the PRx period value. The following edges will start the timer:

- Rising edge (MODE<4:0> = 01001)
- Falling edge (MODE<4:0> = 01010)
- Rising or Falling edge (MODE<4:0> = 01011)

If the timer is halted by clearing the ON bit then another TMRx_ers edge is required after the ON bit is set to resume counting. [Figure 29-9](#) illustrates operation in the rising edge One-Shot mode.

When Edge-Triggered One-Shot mode is used in conjunction with the CCP then the edge-trigger will activate the PWM drive and the PWM drive will deactivate when the timer matches the CCPRx pulse width value and stay deactivated when the timer halts at the PRx period count match.

FIGURE 29-9: EDGE-TRIGGERED ONE-SHOT MODE TIMING DIAGRAM (MODE = 01001)

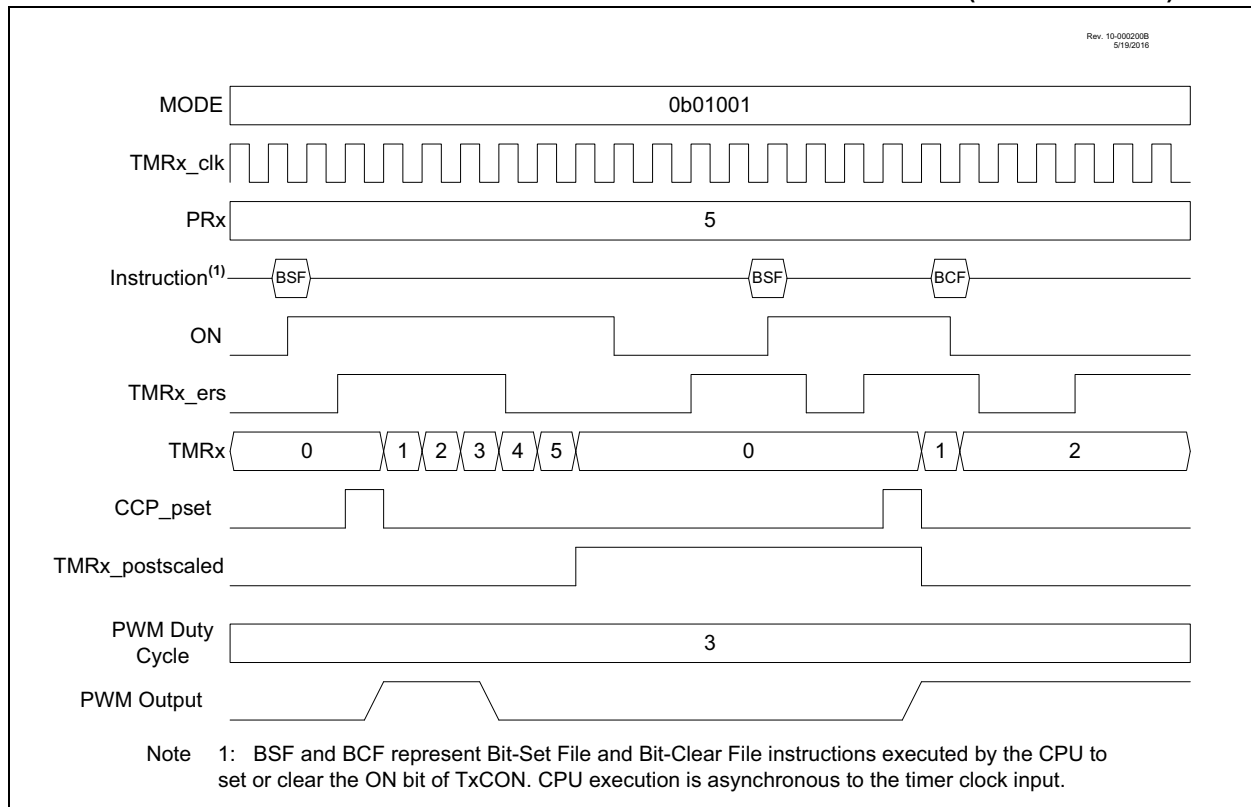

29.5.7 EDGE-TRIGGERED HARDWARE LIMIT ONE-SHOT MODE

In Edge-Triggered Hardware Limit One-Shot modes the timer starts on the first external signal edge after the ON bit is set and resets on all subsequent edges. Only the first edge after the ON bit is set is needed to start the timer. The counter will resume counting automatically two clocks after all subsequent external Reset edges. Edge triggers are as follows:

- Rising edge start and Reset (MODE<4:0> = 01100)
- Falling edge start and Reset (MODE<4:0> = 01101)

The timer resets and clears the ON bit when the timer reaches the period value. External signal edges will have no effect on the ON bit. Figure 29-10 illustrates the rising edge operation.

When this mode is used in conjunction with the CCF trigger, and all subsequent Reset edges, will activate the timer. The timer will deactivate when the timer matches the CC value. The timer will stay deactivated until the timer halts at the PRx period value. A subsequent signal edge resets the timer before the match occurs.

FIGURE 29-10: EDGE-TRIGGERED HARDWARE LIMIT ONE-SHOT MODE TIMING DIAGRAM (MODE = 01100)

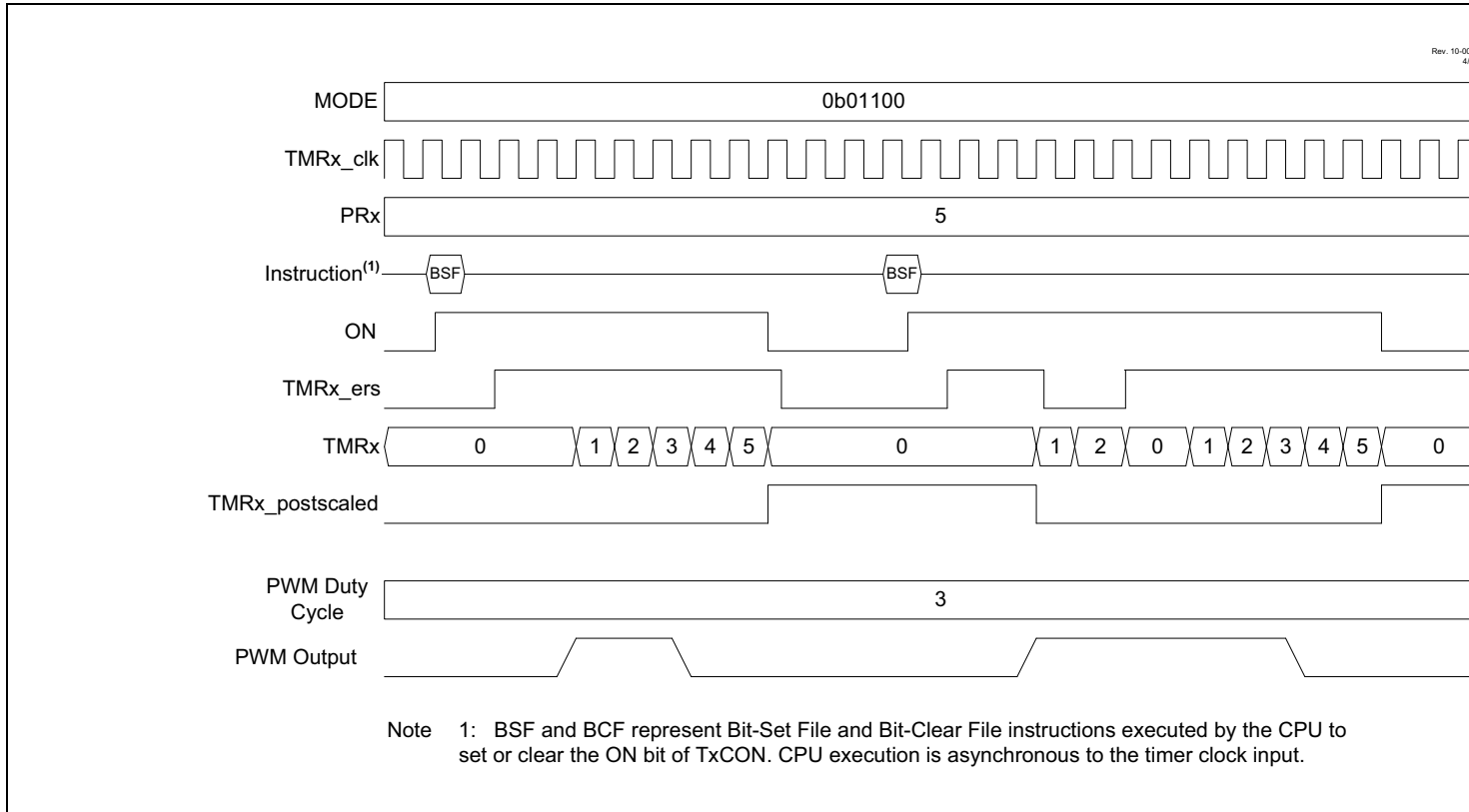

29.5.8 LEVEL RESET, EDGE-TRIGGERED HARDWARE LIMIT ONE-SHOT MODES

In Level -Triggered One-Shot mode the timer count is reset on the external signal level and starts counting on the rising/falling edge of the transition from Reset level to the active level while the ON bit is set. Reset levels are selected as follows:

- Low Reset level (MODE<4:0> = 011110)
- High Reset level (MODE<4:0> = 011111)

When the timer count matches the PRx period count the ON bit is cleared. When the ON bit is cleared by either hardware control a new external signal edge is required to restart the counter.

When Level-Triggered Reset One-Shot mode is used in CCP PWM operation the PWM drive goes active when the timer starts. The PWM drive goes inactive when the CCPRx pulse width count is reached. The PWM drive does not clear the timer count at the PRx period count match.

FIGURE 29-11: LOW LEVEL RESET, EDGE-TRIGGERED HARDWARE LIMIT ONE-SHOT MODE TIMING DIAGRAM

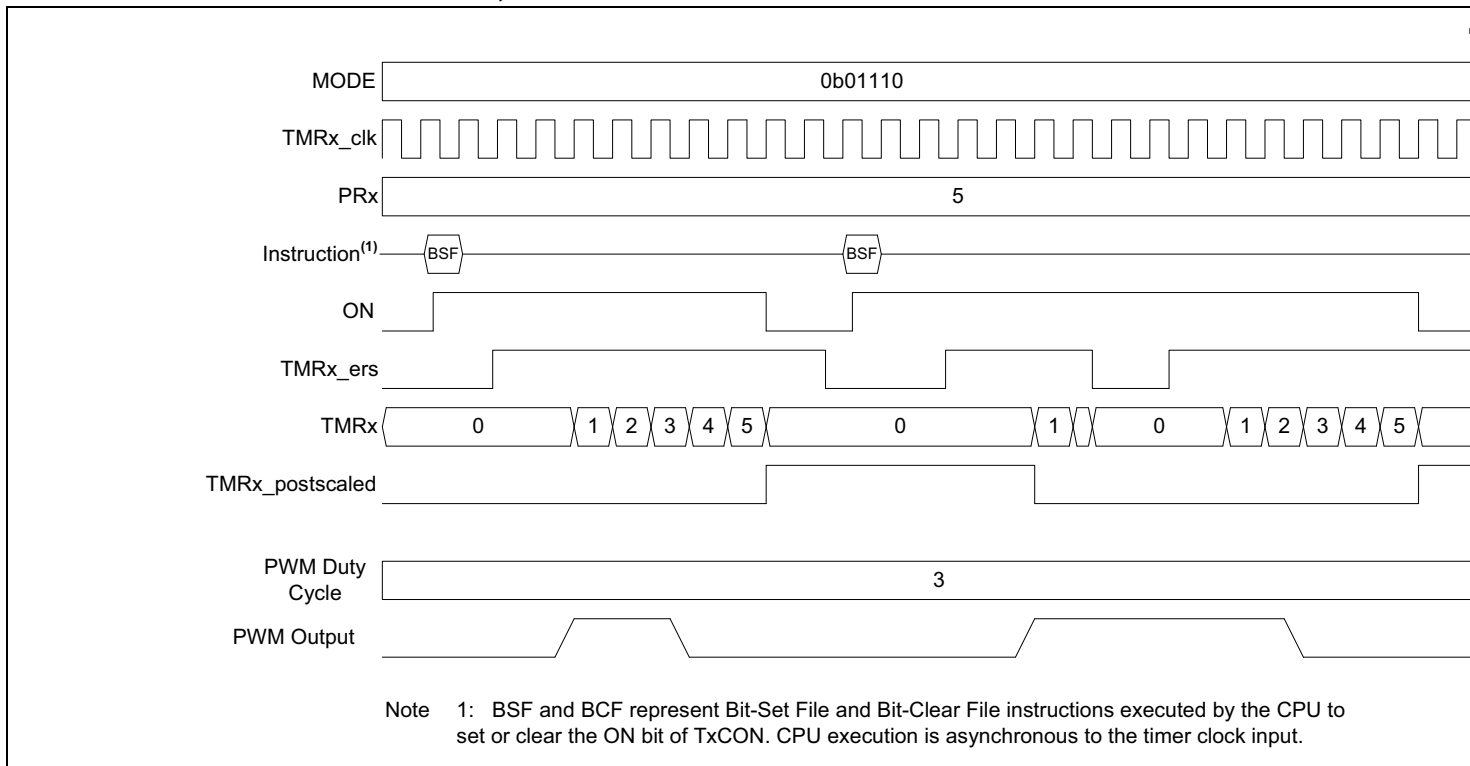

29.5.9 EDGE-TRIGGERED MONOSTABLE MODES

The Edge-Triggered Monostable modes start the timer on an edge from the external Reset signal input, after the ON bit is set, and stop incrementing the timer when the timer matches the PRx period value. The following edges will start the timer:

- Rising edge (MODE<4:0> = 10001)
- Falling edge (MODE<4:0> = 10010)
- Rising or Falling edge (MODE<4:0> = 10011)

When an Edge-Triggered Monostable mode is used in CCP PWM operation the PWM drive goes active when the edge that starts the timer, but will not go active when the timer matches the PRx period value. While the timer is incrementing, additional edges will not affect the CCP PWM.

FIGURE 29-12: RISING EDGE-TRIGGERED MONOSTABLE MODE TIMING DIAGRAM (MODE = 10001)

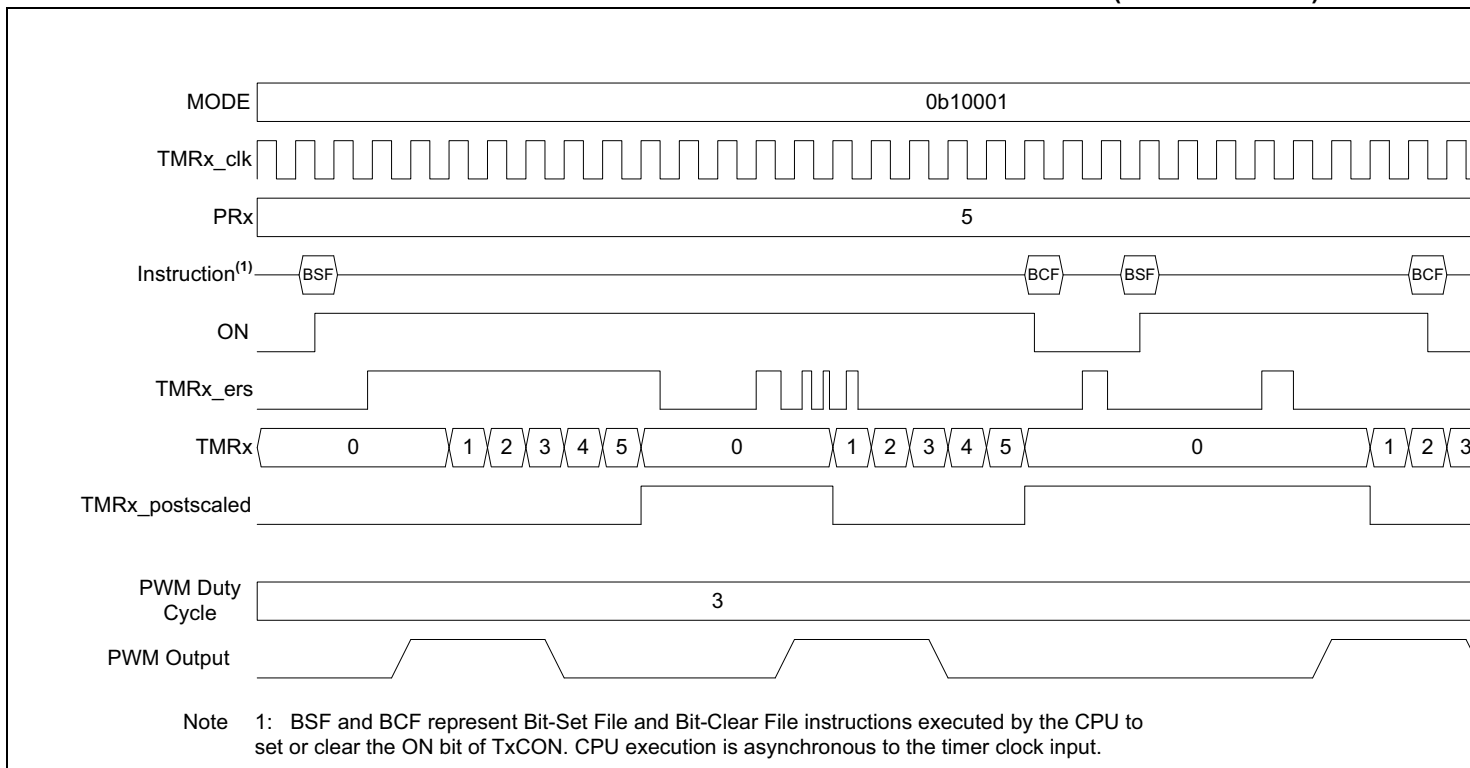

29.5.10 LEVEL-TRIGGERED HARDWARE LIMIT ONE-SHOT MODES

The Level-Triggered Hardware Limit One-Shot modes hold the timer in Reset on an external Reset level and start counting when both the ON bit is set and the external signal is not at the Reset level. If one of either the external signal is not in Reset or the ON bit is set then the other signal being set/made active will start the timer. Reset levels are selected as follows:

- Low Reset level (MODE<4:0> = 10110)

- High Reset level (MODE<4:0> = 10111)

When the timer count matches the PRx period counter, the ON bit is cleared. When the ON bit is cleared by either hardware control the timer will stay in Reset until both the external signal is not at the Reset level.

When Level-Triggered Hardware Limit One-Shot mode is used in conjunction with the CCP PWM operation the PWM drive will be active on an external signal edge or the setting of the ON bit, when the timer is not in Reset.

FIGURE 29-13: LEVEL-TRIGGERED HARDWARE LIMIT ONE-SHOT MODE TIMING DIAGRAM (MODE = 10110)

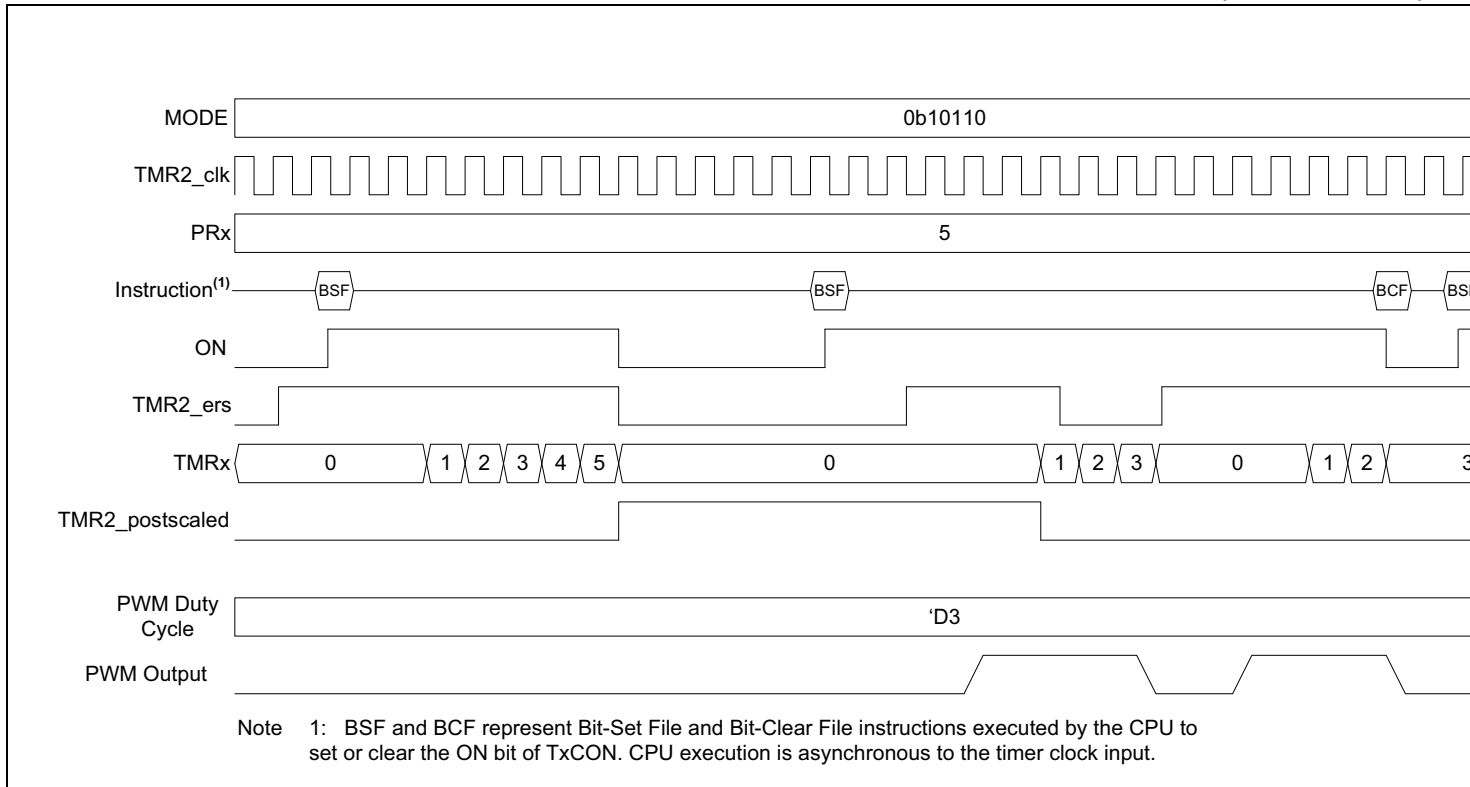

29.6 Timer2 Operation During Sleep

When PSYNC = 1, Timer2 cannot be operated while the processor is in Sleep mode. The contents of the TMR2 and T2PR registers will remain unchanged while processor is in Sleep mode.

When PSYNC = 0, Timer2 will operate in Sleep as long as the clock source selected is also still running. Selecting the LFINTOSC, MFINTOSC, or HFINTOSC oscillator as the timer clock source will keep the selected oscillator running during Sleep.

PIC16(L)F18856/76

29.7 Register Definitions: Timer2/4/6 Control

Long bit name prefixes for the Timer2/4/6 peripherals are shown in Table 29-2. Refer to Section 1.1 “Register and Bit naming conventions” for more information

TABLE 29-2:

Peripheral	Bit Name Prefix
Timer2	T2
Timer4	T4
Timer6	T6

REGISTER 29-1: TxCLKCON: TIMER2/4/6 CLOCK SELECTION REGISTER

U-0	U-0	U-0	U-0	R/W-0/0	R/W-0/0	R/W-0/0	R/W-0/0
—	—	—	—	CS<3:0>			
bit 7							bit 0

Legend:

R = Readable bit

W = Writable bit

U = Unimplemented bit, read as '0'

u = Bit is unchanged

x = Bit is unknown

-n/n = Value at POR and BOR/Value at all other Resets

'1' = Bit is set

'0' = Bit is cleared

bit 7-4

Unimplemented: Read as '0'

bit 3-0

CS<3:0>: Timer2/4/6 Clock Select bits

1111 = Reserved

1110 = Reserved

1101 = LC4_out

1100 = LC3_out

1011 = LC2_out

1010 = LC1_out

1001 = ZCD1_output

1000 = NCO output

0111 = CLKR

0110 = SOSC

0101 = MFINTOSC/16 (31.25 kHz)

0100 = LFINTOSC

0011 = HFINTOSC (16 MHz)

0010 = Fosc

0001 = Fosc/4

0000 = TxCKIPPS

PIC16(L)F18856/76

REGISTER 29-2: TxCON: TIMER2/4/6 CONTROL REGISTER

R/W/HC-0/0	R/W-0/0	R/W-0/0	R/W-0/0	R/W-0/0	R/W-0/0	R/W-0/0	R/W-0/0
ON ⁽¹⁾	CKPS<2:0>			OUTPS<3:0>			
bit 7							bit 0

Legend:

R = Readable bit	W = Writable bit	U = Unimplemented bit, read as '0'
u = Bit is unchanged	x = Bit is unknown	-n/n = Value at POR and BOR/Value at all other Resets
'1' = Bit is set	'0' = Bit is cleared	HC = Bit is cleared by hardware

bit 7 **ON:** Timerx On bit
 1 = Timerx is on
 0 = Timerx is off: all counters and state machines are reset

bit 6-4 **CKPS<2:0>:** Timer2-type Clock Prescale Select bits
 111 = 1:128 Prescaler
 110 = 1:64 Prescaler
 101 = 1:32 Prescaler
 100 = 1:16 Prescaler
 011 = 1:8 Prescaler
 010 = 1:4 Prescaler
 001 = 1:2 Prescaler
 000 = 1:1 Prescaler

bit 3-0 **OUTPS<3:0>:** Timerx Output Postscaler Select bits
 1111 = 1:16 Postscaler
 1110 = 1:15 Postscaler
 1101 = 1:14 Postscaler
 1100 = 1:13 Postscaler
 1011 = 1:12 Postscaler
 1010 = 1:11 Postscaler
 1001 = 1:10 Postscaler
 1000 = 1:9 Postscaler
 0111 = 1:8 Postscaler
 0110 = 1:7 Postscaler
 0101 = 1:6 Postscaler
 0100 = 1:5 Postscaler
 0011 = 1:4 Postscaler
 0010 = 1:3 Postscaler
 0001 = 1:2 Postscaler
 0000 = 1:1 Postscaler

Note 1: In certain modes, the ON bit will be auto-cleared by hardware. See [Section 29.5 “Operation Examples”](#).

PIC16(L)F18856/76

REGISTER 29-3: TxHLT: TIMERx HARDWARE LIMIT CONTROL REGISTER

R/W-0/0	R/W-0/0	R/W-0/0	R/W-0/0	R/W-0/0	R/W-0/0	R/W-0/0	R/W-0/0
PSYNC ^(1, 2)	CKPOL ⁽³⁾	CKSYNC ^(4, 5)	MODE<4:0> ^(6, 7)				
bit 7							bit 0

Legend:

R = Readable bit	W = Writable bit	U = Unimplemented bit, read as '0'
u = Bit is unchanged	x = Bit is unknown	-n/n = Value at POR and BOR/Value at all other Resets
'1' = Bit is set	'0' = Bit is cleared	

bit 7	PSYNC: Timerx Prescaler Synchronization Enable bit ^(1, 2) 1 = TMRx Prescaler Output is synchronized to Fosc/4 0 = TMRx Prescaler Output is not synchronized to Fosc/4
bit 6	CKPOL: Timerx Clock Polarity Selection bit ⁽³⁾ 1 = Falling edge of input clock clocks timer/prescaler 0 = Rising edge of input clock clocks timer/prescaler
bit 5	CKSYNC: Timerx Clock Synchronization Enable bit ^(4, 5) 1 = ON register bit is synchronized to TMR2_clk input 0 = ON register bit is not synchronized to TMR2_clk input
bit 4-0	MODE<4:0>: Timerx Control Mode Selection bits ^(6, 7) See Table 29-1 .

- Note 1:** Setting this bit ensures that reading TMRx will return a valid value.
- Note 2:** When this bit is '1', Timer2 cannot operate in Sleep mode.
- Note 3:** CKPOL should not be changed while ON = 1.
- Note 4:** Setting this bit ensures glitch-free operation when the ON is enabled or disabled.
- Note 5:** When this bit is set then the timer operation will be delayed by two TMRx input clocks after the ON bit is set.
- Note 6:** Unless otherwise indicated, all modes start upon ON = 1 and stop upon ON = 0 (stops occur without affecting the value of TMRx).
- Note 7:** When TMRx = PRx, the next clock clears TMRx, regardless of the operating mode.

PIC16(L)F18856/76

REGISTER 29-4: TxRST: TIMER2/4/6 EXTERNAL RESET SIGNAL SELECTION REGISTER

U-0	U-0	U-0	R/W-0/0	R/W-0/0	R/W-0/0	R/W-0/0	R/W-0/0
—	—	—	RSEL<4:0>				
bit 7							bit 0

Legend:

R = Readable bit	W = Writable bit	U = Unimplemented bit, read as '0'
u = Bit is unchanged	x = Bit is unknown	-n/n = Value at POR and BOR/Value at all other Resets
'1' = Bit is set	'0' = Bit is cleared	

bit 7-5 **Unimplemented:** Read as '0'

bit 4-0 **RSEL<4:0>:** Timer2 External Reset Signal Source Selection bits

- 11111 = Reserved
- :
- :
- :
- 10010 = Reserved
- 10001 = LC4_out
- 10000 = LC3_out
- 01111 = LC2_out
- 01110 = LC1_out
- 01101 = ZCD1_output
- 01100 = C2OUT_sync
- 01011 = C1OUT_sync
- 01010 = PWM7_out
- 01001 = PWM6_out
- 01000 = CCP5_out
- 00111 = CCP4_out
- 00110 = CCP3_out
- 00101 = CCP2_out
- 00100 = CCP1_out
- 00011 = TMR6_postscaled⁽³⁾
- 00010 = TMR4_postscaled⁽²⁾
- 00001 = TMR2_postscaled⁽¹⁾
- 00000 = Pin selected by TxINPPS

- Note 1:** For Timer2, this bit is Reserved.
Note 2: For Timer4, this bit is Reserved.
Note 3: For Timer6, this bit is Reserved.

PIC16(L)F18856/76

TABLE 29-3: SUMMARY OF REGISTERS ASSOCIATED WITH TIMER2

Name	Bit 7	Bit 6	Bit 5	Bit 4	Bit 3	Bit 2	Bit 1	Bit 0	Register on Page
CCP1CON	EN	—	OUT	FMT	MODE<3:0>				452
CCP2CON	EN	—	OUT	FMT	MODE<3:0>				452
CCPTMRS0	C4TSEL<1:0>		C3TSEL<1:0>		C2TSEL<1:0>		C1TSEL<1:0>		455
CCPTMRS1	—	—	P7TSEL<1:0>		P6TSEL<1:0>		C5TSEL<1:0>		455
INTCON	GIE	PEIE	—	—	—	—	—	INTEDG	134
PIE1	OSFIE	CSWIE	—	—	—	—	ADTIE	ADIE	136
PIR1	OSFIF	CSWIF	—	—	—	—	ADTIF	ADIF	145
PR2	Timer2 Module Period Register								425*
TMR2	Holding Register for the 8-bit TMR2 Register								425*
T2CON	ON	CKPS<2:0>			OUTPS<3:0>				441
T2CLKCON	—	—	—	—	CS<3:0>				440
T2RST	—	—	—	RSEL<4:0>				443	
T2HLT	PSYNC	CKPOL	CKSYNC	—	MODE<3:0>				442
PR4	Timer4 Module Period Register								425*
TMR4	Holding Register for the 8-bit TMR4 Register								425*
T4CON	ON	CKPS<2:0>			OUTPS<3:0>				441
T4CLKCON	—	—	—	—	—	CS<3:0>			440
T4RST	—	—	—	RSEL<4:0>				443	
T4HLT	PSYNC	CKPOL	CKSYNC	—	MODE<3:0>				442
PR6	Timer6 Module Period Register								425*
TMR6	Holding Register for the 8-bit TMR6 Register								425*
T6CON	ON	CKPS<2:0>			OUTPS<3:0>				441
T6CLKCON	—	—	—	—	—	CS<2:0>			440
T6RST	—	—	—	RSEL<4:0>				443	
T6HLT	PSYNC	CKPOL	CKSYNC	—	MODE<3:0>				442

Legend: — = unimplemented location, read as '0'. Shaded cells are not used for Timer2 module.

* Page provides register information.

PIC16(L)F18856/76

30.0 CAPTURE/COMPARE/PWM MODULES

The Capture/Compare/PWM module is a peripheral that allows the user to time and control different events, and to generate Pulse-Width Modulation (PWM) signals. In Capture mode, the peripheral allows the timing of the duration of an event. The Compare mode allows the user to trigger an external event when a predetermined amount of time has expired. The PWM mode can generate Pulse-Width Modulated signals of varying frequency and duty cycle.

The Capture/Compare/PWM modules available are shown in [Table 30-1](#).

TABLE 30-1: AVAILABLE CCP MODULES

Device	CCP1	CCP2	CCP3	CCP4	CCP5
PIC16(L)F18856/76	•	•	•	•	•

The Capture and Compare functions are identical for all CCP modules.

Note 1: In devices with more than one CCP module, it is very important to pay close attention to the register names used. A number placed after the module acronym is used to distinguish between separate modules. For example, the CCP1CON and CCP2CON control the same operational aspects of two completely different CCP modules.

2: Throughout this section, generic references to a CCP module in any of its operating modes may be interpreted as being equally applicable to CCPx module. Register names, module signals, I/O pins, and bit names may use the generic designator 'x' to indicate the use of a numeral to distinguish a particular module, when required.

PIC16(L)F18856/76

30.1 Capture Mode

The Capture mode function described in this section is available and identical for all CCP modules.

Capture mode makes use of the 16-bit Timer1 resource. When an event occurs on the capture source, the 16-bit CCPRxH:CCPRxL register pair captures and stores the 16-bit value of the TMR1H:TMR1L register pair, respectively. An event is defined as one of the following and is configured by the CCPxMODE<3:0> bits of the CCPxCON register:

- Every falling edge
- Every rising edge
- Every 4th rising edge
- Every 16th rising edge

When a capture is made, the Interrupt Request Flag bit CCPxIF of the PIR6 register is set. The interrupt flag must be cleared in software. If another capture occurs before the value in the CCPRxH, CCPRxL register pair is read, the old captured value is overwritten by the new captured value.

Figure 30-1 shows a simplified diagram of the capture operation.

30.1.1 CAPTURE SOURCES

In Capture mode, the CCPx pin should be configured as an input by setting the associated TRIS control bit.

Note: If the CCPx pin is configured as an output, a write to the port can cause a capture condition.

The capture source is selected by configuring the CCPxCTS<2:0> bits of the CCPxCON register. The following sources can be selected:

- CCPxPPS input
- C1OUT_sync
- C2OUT_sync
- IOC_interrupt
- LC1_out
- LC2_out
- LC3_out
- LC4_out

FIGURE 30-1: CAPTURE MODE OPERATION BLOCK DIAGRAM

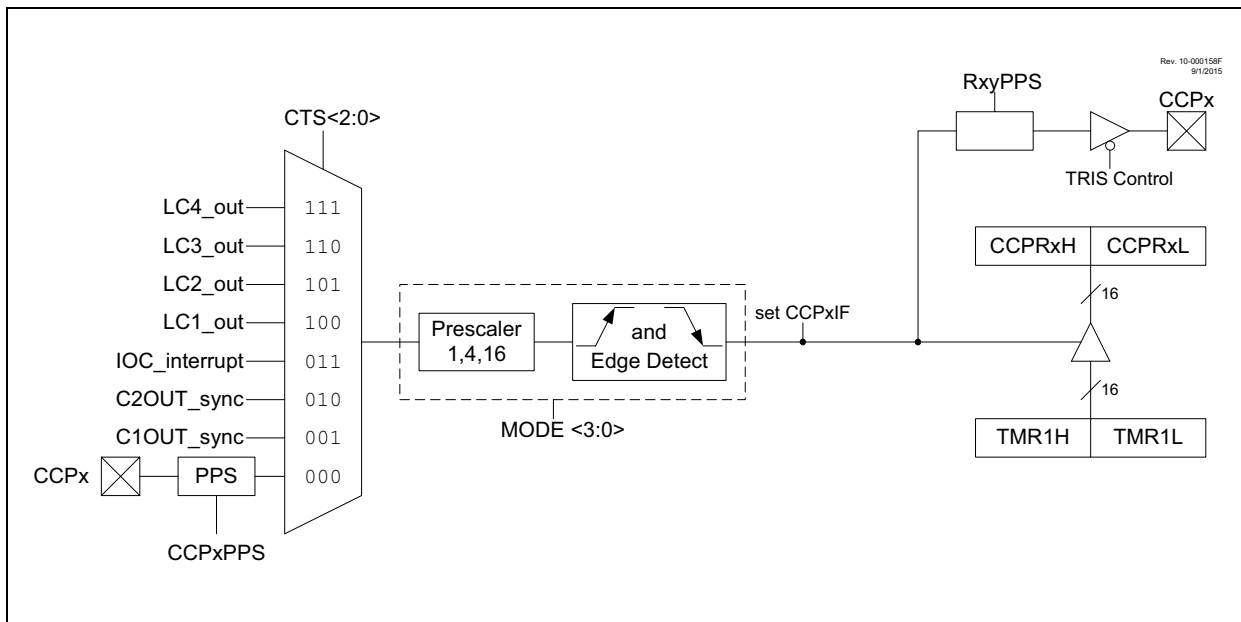

PIC16(L)F18856/76

30.1.2 TIMER1 MODE RESOURCE

Timer1 must be running in Timer mode or Synchronized Counter mode for the CCP module to use the capture feature. In Asynchronous Counter mode, the capture operation may not work.

See [Section 28.0 “Timer1/3/5 Module with Gate Control”](#) for more information on configuring Timer1.

30.1.3 SOFTWARE INTERRUPT MODE

When the Capture mode is changed, a false capture interrupt may be generated. The user should keep the CCPxIE interrupt enable bit of the PIE6 register clear to avoid false interrupts. Additionally, the user should clear the CCPxIF interrupt flag bit of the PIR6 register following any change in Operating mode.

Note: Clocking Timer1 from the system clock (Fosc) should not be used in Capture mode. In order for Capture mode to recognize the trigger event on the CCPx pin, Timer1 must be clocked from the instruction clock (Fosc/4) or from an external clock source.

30.1.4 CCP PRESCALER

There are four prescaler settings specified by the CCPxMODE<3:0> bits of the CCPxCON register. Whenever the CCP module is turned off, or the CCP module is not in Capture mode, the prescaler counter is cleared. Any Reset will clear the prescaler counter.

Switching from one capture prescaler to another does not clear the prescaler and may generate a false interrupt. To avoid this unexpected operation, turn the module off by clearing the CCPxCON register before changing the prescaler. [Example 30-1](#) demonstrates the code to perform this function.

EXAMPLE 30-1: CHANGING BETWEEN CAPTURE PRESCALERS

```
BANKSEL CCPxCON    ;Set Bank bits to point
                   ;to CCPxCON
CLRF    CCPxCON    ;Turn CCP module off
MOVLW  NEW_CAPT_PS ;Load the W reg with
                   ;the new prescaler
                   ;move value and CCP ON
MOVWF  CCPxCON    ;Load CCPxCON with this
                   ;value
```

30.1.5 CAPTURE DURING SLEEP

Capture mode depends upon the Timer1 module for proper operation. There are two options for driving the Timer1 module in Capture mode. It can be driven by the instruction clock (Fosc/4), or by an external clock source.

When Timer1 is clocked by Fosc/4, Timer1 will not increment during Sleep. When the device wakes from Sleep, Timer1 will continue from its previous state.

Capture mode will operate during Sleep when Timer1 is clocked by an external clock source.

30.2 Compare Mode

The Compare mode function described in this section is available and identical for all CCP modules.

Compare mode makes use of the 16-bit Timer1 resource. The 16-bit value of the CCPRxH:CCPRxL register pair is constantly compared against the 16-bit value of the TMR1H:TMR1L register pair. When a match occurs, one of the following events can occur:

- Toggle the CCPx output
- Set the CCPx output
- Clear the CCPx output
- Generate an Auto-conversion Trigger
- Generate a Software Interrupt

The action on the pin is based on the value of the CCPxMODE<3:0> control bits of the CCPxCON register. At the same time, the interrupt flag CCPxIF bit is set, and an ADC conversion can be triggered, if selected.

All Compare modes can generate an interrupt and trigger and ADC conversion.

[Figure 30-2](#) shows a simplified diagram of the compare operation.

FIGURE 30-2: COMPARE MODE OPERATION BLOCK DIAGRAM

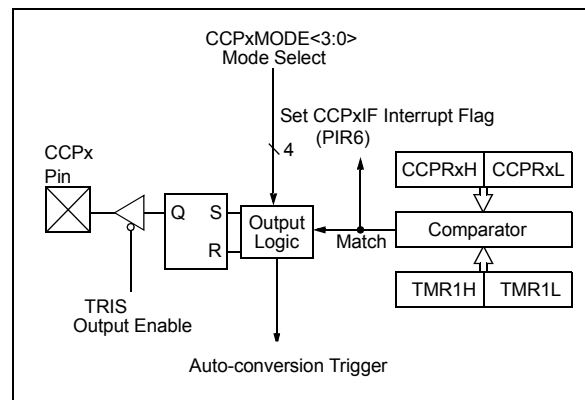

PIC16(L)F18856/76

30.2.1 CCPX PIN CONFIGURATION

The software must configure the CCPx pin as an output by clearing the associated TRIS bit and defining the appropriate output pin through the RxyPPS registers. See [Section 13.0 “Peripheral Pin Select \(PPS\) Module”](#) for more details.

The CCP output can also be used as an input for other peripherals.

Note: Clearing the CCPxCON register will force the CCPx compare output latch to the default low level. This is not the PORT I/O data latch.

30.2.2 TIMER1 MODE RESOURCE

In Compare mode, Timer1 must be running in either Timer mode or Synchronized Counter mode. The compare operation may not work in Asynchronous Counter mode.

See [Section 28.0 “Timer1/3/5 Module with Gate Control”](#) for more information on configuring Timer1.

Note: Clocking Timer1 from the system clock (Fosc) should not be used in Compare mode. In order for Compare mode to recognize the trigger event on the CCPx pin, Timer1 must be clocked from the instruction clock (Fosc/4) or from an external clock source.

30.2.3 AUTO-CONVERSION TRIGGER

All CCPx modes set the CCP interrupt flag (CCPxFIF). When this flag is set and a match occurs, an Auto-conversion Trigger can take place if the CCP module is selected as the conversion trigger source.

Refer to [Section 23.2.6 “Auto-Conversion Trigger”](#) for more information.

Note: Removing the match condition by changing the contents of the CCPRxH and CCPRxL register pair, between the clock edge that generates the Auto-conversion Trigger and the clock edge that generates the Timer1 Reset, will preclude the Reset from occurring.

30.2.4 COMPARE DURING SLEEP

Since Fosc is shut down during Sleep mode, the Compare mode will not function properly during Sleep, unless the timer is running. The device will wake on interrupt (if enabled).

30.3 PWM Overview

Pulse-Width Modulation (PWM) is a scheme that provides power to a load by switching quickly between fully on and fully off states. The PWM signal resembles a square wave where the high portion of the signal is considered the on state and the low portion of the signal is considered the off state. The high portion, also known as the pulse width, can vary in time and is defined in steps. A larger number of steps applied, which lengthens the pulse width, also supplies more power to the load. Lowering the number of steps applied, which shortens the pulse width, supplies less power. The PWM period is defined as the duration of one complete cycle or the total amount of on and off time combined.

PWM resolution defines the maximum number of steps that can be present in a single PWM period. A higher resolution allows for more precise control of the pulse width time and in turn the power that is applied to the load.

The term duty cycle describes the proportion of the on time to the off time and is expressed in percentages, where 0% is fully off and 100% is fully on. A lower duty cycle corresponds to less power applied and a higher duty cycle corresponds to more power applied.

[Figure 30-3](#) shows a typical waveform of the PWM signal.

30.3.1 STANDARD PWM OPERATION

The standard PWM function described in this section is available and identical for all CCP modules.

The standard PWM mode generates a Pulse-Width Modulation (PWM) signal on the CCPx pin with up to ten bits of resolution. The period, duty cycle, and resolution are controlled by the following registers:

- PR2 registers
- T2CON registers
- CCPRxL registers
- CCPxCON registers

[Figure 30-4](#) shows a simplified block diagram of PWM operation.

Note: The corresponding TRIS bit must be cleared to enable the PWM output on the CCPx pin.

FIGURE 30-3: CCP PWM OUTPUT SIGNAL

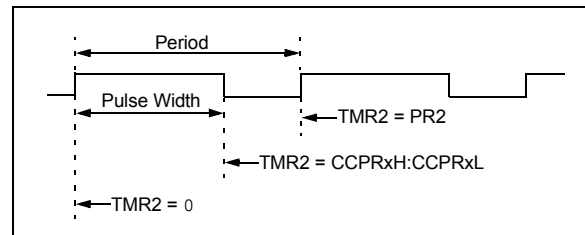

PIC16(L)F18856/76

FIGURE 30-4: SIMPLIFIED PWM BLOCK DIAGRAM

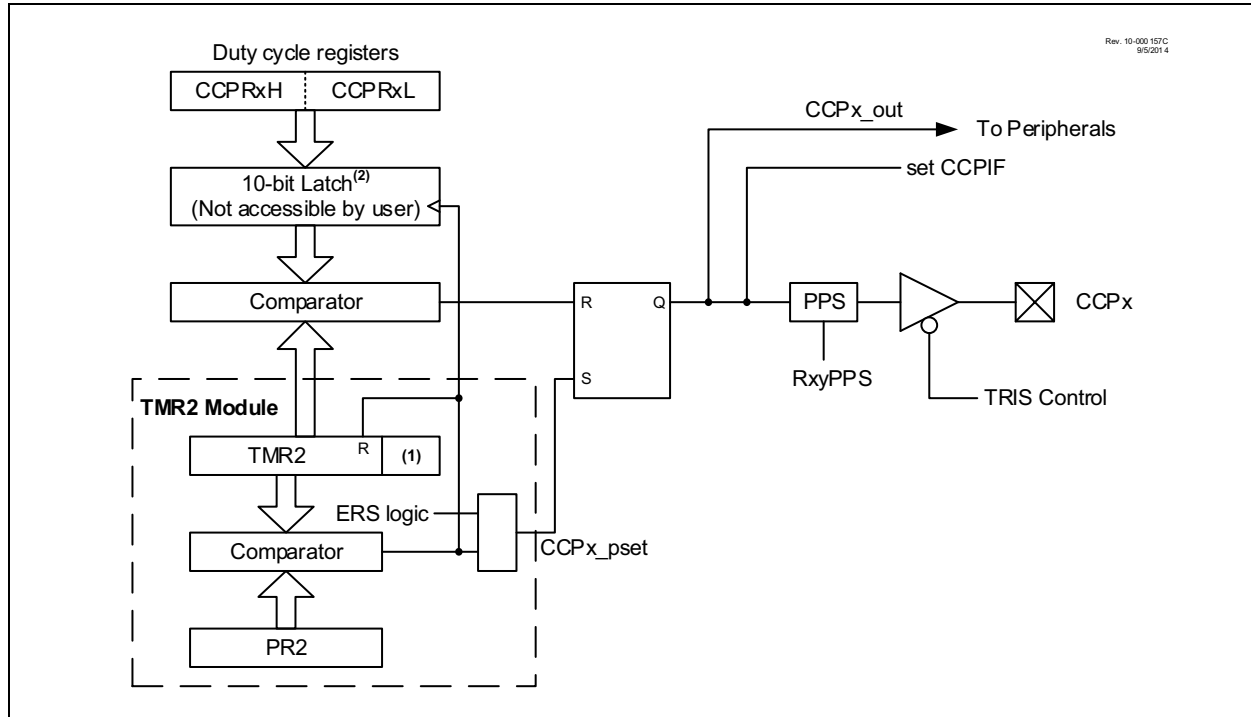

30.3.2 SETUP FOR PWM OPERATION

The following steps should be taken when configuring the CCP module for standard PWM operation:

1. Use the desired output pin RxyPPS control to select CCPx as the source and disable the CCPx pin output driver by setting the associated TRIS bit.
2. Load the PR2 register with the PWM period value.
3. Configure the CCP module for the PWM mode by loading the CCPxCON register with the appropriate values.
4. Load the CCPRxL register, and the CCPRxH register with the PWM duty cycle value and configure the CCPxFMT bit of the CCPxCON register to set the proper register alignment.
5. Configure and start Timer2:
 - Clear the TMR2IF interrupt flag bit of the PIR4 register. See Note below.
 - Configure the T2CKPS bits of the T2CON register with the Timer prescale value.
 - Enable the Timer by setting the TMR2ON bit of the T2CON register.

6. Enable PWM output pin:
 - Wait until the Timer overflows and the TMR2IF bit of the PIR4 register is set. See Note below.
 - Enable the CCPx pin output driver by clearing the associated TRIS bit.

Note: In order to send a complete duty cycle and period on the first PWM output, the above steps must be included in the setup sequence. If it is not critical to start with a complete PWM signal on the first output, then step 6 may be ignored.

30.3.3 CCP/PWM CLOCK SELECTION

The PIC16F18855/75 allows each individual CCP and PWM module to select the timer source that controls the module. Each module has an independent selection.

As there are up to three 8-bit timers with auto-reload (Timer2/4/6), PWM mode on the CCP and PWM modules can use any of these timers. The CCPTMRS0 and CCPTMRS1 registers is used to select which timer is used.

PIC16(L)F18856/76

30.3.4 TIMER2 TIMER RESOURCE

This device has a newer version of the TMR2 module that has many new modes, which allow for greater customization and control of the PWM signals than on older parts. Refer to [Section 29.5, Operation Examples](#) for examples of PWM signal generation using the different modes of Timer2. The CCP operation requires that the timer used as the PWM time base has the FOSC/4 clock source selected

30.3.5 PWM PERIOD

The PWM period is specified by the PR2/4/6 register of Timer2/4/6. The PWM period can be calculated using the formula of [Equation 30-1](#).

EQUATION 30-1: PWM PERIOD

$$PWM\ Period = [(PR2) + 1] \cdot 4 \cdot T_{OSC} \cdot (TMR2\ Prescale\ Value)$$

Note 1: $T_{OSC} = 1/F_{OSC}$

When TMR2/4/6 is equal to PR2, the following three events occur on the next increment cycle:

- TMR2/4/6 is cleared
- The CCPx pin is set. (Exception: If the PWM duty cycle = 0%, the pin will not be set.)
- The PWM duty cycle is transferred from the CCPRxL/H register pair into a 10-bit buffer.

Note: The Timer postscaler (see [Section 29.4 “Timer2 Interrupt”](#)) is not used in the determination of the PWM frequency.

30.3.6 PWM DUTY CYCLE

The PWM duty cycle is specified by writing a 10-bit value to the CCPRxH:CCPRxL register pair. The alignment of the 10-bit value is determined by the CCPRxFMT bit of the CCPxCON register (see [Figure 30-5](#)). The CCPRxH:CCPRxL register pair can be written to at any time; however the duty cycle value is not latched into the 10-bit buffer until after a match between PR2 and TMR2.

[Equation 30-2](#) is used to calculate the PWM pulse width.

[Equation 30-3](#) is used to calculate the PWM duty cycle ratio.

FIGURE 30-5: PWM 10-BIT ALIGNMENT

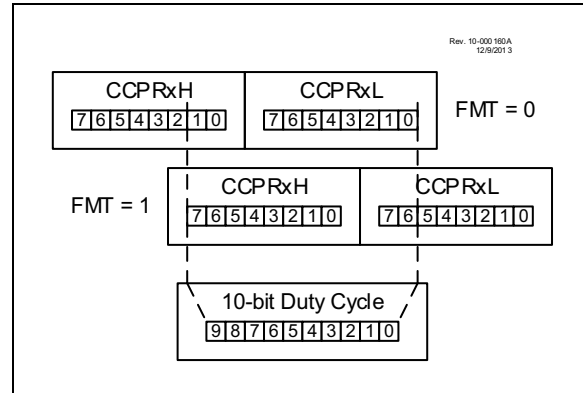

EQUATION 30-2: PULSE WIDTH

$$Pulse\ Width = (CCPRxH:CCPRxL\ register\ pair) \cdot T_{OSC} \cdot (TMR2\ Prescale\ Value)$$

EQUATION 30-3: DUTY CYCLE RATIO

$$Duty\ Cycle\ Ratio = \frac{(CCPRxH:CCPRxL\ register\ pair)}{4(PR2 + 1)}$$

CCPRxH:CCPRxL register pair are used to double buffer the PWM duty cycle. This double buffering is essential for glitchless PWM operation.

The 8-bit timer TMR2 register is concatenated with either the 2-bit internal system clock (FOSC), or two bits of the prescaler, to create the 10-bit time base. The system clock is used if the Timer2 prescaler is set to 1:1.

When the 10-bit time base matches the CCPRxH:CCPRxL register pair, then the CCPx pin is cleared (see [Figure 30-4](#)).

30.3.7 PWM RESOLUTION

The resolution determines the number of available duty cycles for a given period. For example, a 10-bit resolution will result in 1024 discrete duty cycles, whereas an 8-bit resolution will result in 256 discrete duty cycles.

The maximum PWM resolution is ten bits when PR2 is 255. The resolution is a function of the PR2 register value as shown by [Equation 30-4](#).

EQUATION 30-4: PWM RESOLUTION

$$Resolution = \frac{\log[4(PR2 + 1)]}{\log(2)}\ bits$$

Note: If the pulse width value is greater than the period the assigned PWM pin(s) will remain unchanged.

PIC16(L)F18856/76

TABLE 30-2: EXAMPLE PWM FREQUENCIES AND RESOLUTIONS (Fosc = 20 MHz)

PWM Frequency	1.22 kHz	4.88 kHz	19.53 kHz	78.12 kHz	156.3 kHz	208.3 kHz
Timer Prescale	16	4	1	1	1	1
PR2 Value	0xFF	0xFF	0xFF	0x3F	0x1F	0x17
Maximum Resolution (bits)	10	10	10	8	7	6.6

TABLE 30-3: EXAMPLE PWM FREQUENCIES AND RESOLUTIONS (Fosc = 8 MHz)

PWM Frequency	1.22 kHz	4.90 kHz	19.61 kHz	76.92 kHz	153.85 kHz	200.0 kHz
Timer Prescale	16	4	1	1	1	1
PR2 Value	0x65	0x65	0x65	0x19	0x0C	0x09
Maximum Resolution (bits)	8	8	8	6	5	5

30.3.8 OPERATION IN SLEEP MODE

In Sleep mode, the TMR2 register will not increment and the state of the module will not change. If the CCPx pin is driving a value, it will continue to drive that value. When the device wakes up, TMR2 will continue from its previous state.

30.3.9 CHANGES IN SYSTEM CLOCK FREQUENCY

The PWM frequency is derived from the system clock frequency. Any changes in the system clock frequency will result in changes to the PWM frequency. See [Section 6.0 “Oscillator Module \(with Fail-Safe Clock Monitor\)”](#) for additional details.

30.3.10 EFFECTS OF RESET

Any Reset will force all ports to Input mode and the CCP registers to their Reset states.

PIC16(L)F18856/76

30.4 Register Definitions: CCP Control

Long bit name prefixes for the CCP peripherals are shown in [Section 1.1 “Register and Bit naming conventions”](#).

TABLE 30-4: LONG BIT NAMES PREFIXES FOR CCP PERIPHERALS

Peripheral	Bit Name Prefix
CCP1	CCP1
CCP2	CCP2
CCP3	CCP3
CCP4	CCP4
CCP5	CCP5

REGISTER 30-1: CCPxCON: CCPx CONTROL REGISTER

R/W-0/0	U-0	R-x	R/W-0/0	R/W-0/0	R/W-0/0	R/W-0/0	R/W-0/0	
EN	—	OUT	FMT	MODE<3:0>				
bit 7								bit 0

Legend:

R = Readable bit	W = Writable bit	U = Unimplemented bit, read as '0'
u = Bit is unchanged	x = Bit is unknown	-n/n = Value at POR and BOR/Value at all other Reset
'1' = Bit is set	'0' = Bit is cleared	

- bit 7 **EN:** CCPx Module Enable bit
1 = CCPx is enabled
0 = CCPx is disabled
- bit 6 **Unimplemented:** Read as '0'
- bit 5 **OUT:** CCPx Output Data bit (read-only)
- bit 4 **FMT:** CCPW (Pulse Width) Alignment bit
MODE = Capture mode
Unused
MODE = Compare mode
Unused
MODE = PWM mode
1 = Left-aligned format
0 = Right-aligned format

PIC16(L)F18856/76

REGISTER 30-1: CCPxCON: CCPx CONTROL REGISTER (CONTINUED)

bit 3-0 **MODE<3:0>**: CCPx Mode Select bits⁽¹⁾

- 1111 = PWM mode
- 1110 = Reserved
- 1101 = Reserved
- 1100 = Reserved

- 1011 = Compare mode: output will pulse 0-1-0; Clears TMR1
- 1010 = Compare mode: output will pulse 0-1-0
- 1001 = Compare mode: clear output on compare match
- 1000 = Compare mode: set output on compare match

- 0111 = Capture mode: every 16th rising edge of CCPx input
- 0110 = Capture mode: every 4th rising edge of CCPx input
- 0101 = Capture mode: every rising edge of CCPx input
- 0100 = Capture mode: every falling edge of CCPx input

- 0011 = Capture mode: every edge of CCPx input
- 0010 = Compare mode: toggle output on match
- 0001 = Compare mode: toggle output on match; clear TMR1
- 0000 = Capture/Compare/PWM off (resets CCPx module)

Note 1: All modes will set the CCPxIF bit, and will trigger an ADC conversion if CCPx is selected as the ADC trigger source.

PIC16(L)F18856/76

REGISTER 30-2: CCPxCAP: CAPTURE INPUT SELECTION REGISTER

U-0	U-0	U-0	U-0	U-0	R/W-0/x	R/W-0/x	R/W-0/x
—	—	—	—	—	CTS<2:0>		
bit 7					bit 0		

Legend:

R = Readable bit W = Writable bit U = Unimplemented bit, read as '0'
u = Bit is unchanged x = Bit is unknown -n/n = Value at POR and BOR/Value at all other Reset
'1' = Bit is set '0' = Bit is cleared

bit 7-3 **Unimplemented:** Read as '0'
bit 2-0 **CTS<2:0>:** Capture Trigger Input Selection bits

CTS	CCP1.capture	CCP2.capture	CCP3.capture	CCP4.capture	CCP5.capture
111	LC4_out				
110	LC3_out				
101	LC2_out				
100	LC1_out				
011	IOC_interrupt				
010	C2OUT				
001	C1OUT				
000	CCP1PPS	CCP2PPS	CCP3PPS	CCP4PPS	CCP5PPS

REGISTER 30-3: CCPRxL REGISTER: CCPx REGISTER LOW BYTE

R/W-x/x	R/W-x/x	R/W-x/x	R/W-x/x	R/W-x/x	R/W-x/x	R/W-x/x	R/W-x/x
CCPRx<7:0>							
bit 7					bit 0		

Legend:

R = Readable bit W = Writable bit U = Unimplemented bit, read as '0'
u = Bit is unchanged x = Bit is unknown -n/n = Value at POR and BOR/Value at all other Reset
'1' = Bit is set '0' = Bit is cleared

bit 7-0 CCPxMODE = Capture mode
CCPRxL<7:0>: Capture value of TMR1L
CCPxMODE = Compare mode
CCPRxL<7:0>: LS Byte compared to TMR1L
CCPxMODE = PWM modes when CCPxFMT = 0:
CCPRxL<7:0>: Pulse-width Least Significant eight bits
CCPxMODE = PWM modes when CCPxFMT = 1:
CCPRxL<7:6>: Pulse-width Least Significant two bits
CCPRxL<5:0>: Not used.

PIC16(L)F18856/76

REGISTER 30-4: CCPRxH REGISTER: CCPx REGISTER HIGH BYTE

R/W-x/x	R/W-x/x	R/W-x/x	R/W-x/x	R/W-x/x	R/W-x/x	R/W-x/x	R/W-x/x
CCPRx<15:8>							
bit 7							bit 0

Legend:

R = Readable bit	W = Writable bit	U = Unimplemented bit, read as '0'
u = Bit is unchanged	x = Bit is unknown	-n/n = Value at POR and BOR/Value at all other Reset
'1' = Bit is set	'0' = Bit is cleared	

bit 7-0 CCPxMODE = Capture mode
CCPRxH<7:0>: Captured value of TMR1H
CCPxMODE = Compare mode
CCPRxH<7:0>: MS Byte compared to TMR1H
CCPxMODE = PWM modes when CCPxFMT = 0:
CCPRxH<7:2>: Not used
CCPRxH<1:0>: Pulse-width Most Significant two bits
CCPxMODE = PWM modes when CCPxFMT = 1:
CCPRxH<7:0>: Pulse-width Most Significant eight bits

REGISTER 30-5: CCPTMRS0: CCP TIMERS CONTROL 0 REGISTER

R/W-0/0	R/W-1/1	R/W-0/0	R/W-1/1	R/W-0/0	R/W-1/1	R/W-0/0	R/W-1/1
C4TSEL<1:0>		C3TSEL<1:0>		C2TSEL<1:0>		C1TSEL<1:0>	
bit 7							bit 0

Legend:

R = Readable bit	W = Writable bit	U = Unimplemented bit, read as '0'
u = Bit is unchanged	x = Bit is unknown	-n/n = Value at POR and BOR/Value at all other Reset
'1' = Bit is set	'0' = Bit is cleared	

bit 7-6 **C4TSEL<1:0>**: CCP4 Timer Selection
 11 = CCP4 based on TMR5 (Capture/Compare) or TMR6 (PWM)
 10 = CCP4 based on TMR3 (Capture/Compare) or TMR4 (PWM)
 01 = CCP4 based on TMR1 (Capture/Compare) or TMR2 (PWM)
 00 = Reserved

bit 5-4 **C3TSEL<1:0>**: CCP4 Timer Selection
 11 = CCP3 based on TMR5 (Capture/Compare) or TMR6 (PWM)
 10 = CCP3 based on TMR3 (Capture/Compare) or TMR4 (PWM)
 01 = CCP3 based on TMR1 (Capture/Compare) or TMR2 (PWM)
 00 = Reserved

bit 3-2 **C2TSEL<1:0>**: CCP4 Timer Selection
 11 = CCP2 based on TMR5 (Capture/Compare) or TMR6 (PWM)
 10 = CCP2 based on TMR3 (Capture/Compare) or TMR4 (PWM)
 01 = CCP2 based on TMR1 (Capture/Compare) or TMR2 (PWM)
 00 = Reserved

bit 1-0 **C1TSEL<1:0>**: CCP4 Timer Selection
 11 = CCP1 based on TMR5 (Capture/Compare) or TMR6 (PWM)
 10 = CCP1 based on TMR3 (Capture/Compare) or TMR4 (PWM)
 01 = CCP1 based on TMR1 (Capture/Compare) or TMR2 (PWM)
 00 = Reserved

PIC16(L)F18856/76

REGISTER 30-6: CCPTMRS1: CCP TIMERS CONTROL 1 REGISTER

U-0	U-0	R/W-0/0	R/W-1/1	R/W-0/0	R/W-1/1	R/W-0/0	R/W-1/1
—	—	P7TSEL<1:0>		P6TSEL<1:0>		C5TSEL<1:0>	
bit 7						bit 0	

Legend:

R = Readable bit	W = Writable bit	U = Unimplemented bit, read as '0'
u = Bit is unchanged	x = Bit is unknown	-n/n = Value at POR and BOR/Value at all other Reset
'1' = Bit is set	'0' = Bit is cleared	

bit 7-6 **Unimplemented:** Read as '0'

bit 5-4 **P7TSEL<1:0>:** PWM7 Timer Selection

11 = PWM7 based on TMR6

10 = PWM7 based on TMR4

01 = PWM7 based on TMR2

00 = Reserved

bit 3-2 **P6TSEL<1:0>:** PWM6 Timer Selection

11 = PWM6 based on TMR6

10 = PWM6 based on TMR4

01 = PWM6 based on TMR2

00 = Reserved

bit 1-0 **C5TSEL<1:0>:** CCP5 Timer Selection

11 = CCP5 based on TMR5 (Capture/Compare) or TMR6 (PWM)

10 = CCP5 based on TMR3 (Capture/Compare) or TMR4 (PWM)

01 = CCP5 based on TMR1 (Capture/Compare) or TMR2 (PWM)

00 = Reserved

PIC16(L)F18856/76

TABLE 30-5: SUMMARY OF REGISTERS ASSOCIATED WITH CCPx

Name	Bit 7	Bit 6	Bit 5	Bit 4	Bit 3	Bit 2	Bit 1	Bit 0	Register on Page	
INTCON	GIE	PEIE	—	—	—	—	—	INTEDG	134	
PIR4	—	—	TMR6IF	TMR5IF	TMR4IF	TMR3IF	TMR2IF	TMR1IF	148	
PIE4	—	—	TMR6IE	TMR5IE	TMR4IE	TMR3IE	TMR2IE	TMR1IE	139	
CCP1CON	EN	—	OUT	FMT	MODE<3:0>				452	
CCP1CAP	—	—	—	—	—	CTS<2:0>			454	
CCPR1L	Capture/Compare/PWM Register 1 (LSB)								454	
CCPR1H	Capture/Compare/PWM Register 1 (MSB)								455	
CCP2CON	EN	—	OUT	FMT	MODE<3:0>				452	
CCP2CAP	—	—	—	—	—	CTS<2:0>			454	
CCPR2L	Capture/Compare/PWM Register 1 (LSB)								454	
CCPR2H	Capture/Compare/PWM Register 1 (MSB)								454	
CCPTMRS0	C4TSEL<1:0>		C3TSEL<1:0>		C2TSEL<1:0>		C1TSEL<1:0>		455	
CCPTMRS1	—	—	P7TSEL<1:0>		P6TSEL<1:0>		C5TSEL<1:0>		456	
CCP1PPS	—	—	—	CCP1PPS<4:0>						249
CCP2PPS	—	—	—	CCP2PPS<4:0>						249
RxyPPS	—	—	—	RxyPPS<4:0>						250
ADACT	—	—	—	ADACT<4:0>						359
CLCxSELY	—	—	—	LCxDyS<4:0>						329
CWG1ISM	—	—	—	—	IS<3:0>				312	
MDSRC	—	—	—	MDMS<4:0>						399
MDCARH	—	—	—	—	MDCHS<3:0>				400	
MDCARL	—	—	—	—	MDCLS<3:0>				401	

Legend: — = Unimplemented location, read as '0'. Shaded cells are not used by the CCP module.

PIC16(L)F18856/76

31.0 MASTER SYNCHRONOUS SERIAL PORT (MSSP) MODULES

31.1 MSSP Module Overview

The Master Synchronous Serial Port (MSSP) module is a serial interface useful for communicating with other peripheral or microcontroller devices. These peripheral devices may be serial EEPROMs, shift registers, display drivers, A/D converters, etc. The MSSP module can operate in one of two modes:

- Serial Peripheral Interface (SPI)
- Inter-Integrated Circuit (I²C)

The SPI interface supports the following modes and features:

- Master mode
- Slave mode
- Clock Parity
- Slave Select Synchronization (Slave mode only)
- Daisy-chain connection of slave devices

Figure 31-1 is a block diagram of the SPI interface module.

FIGURE 31-1: MSSP BLOCK DIAGRAM (SPI MODE)

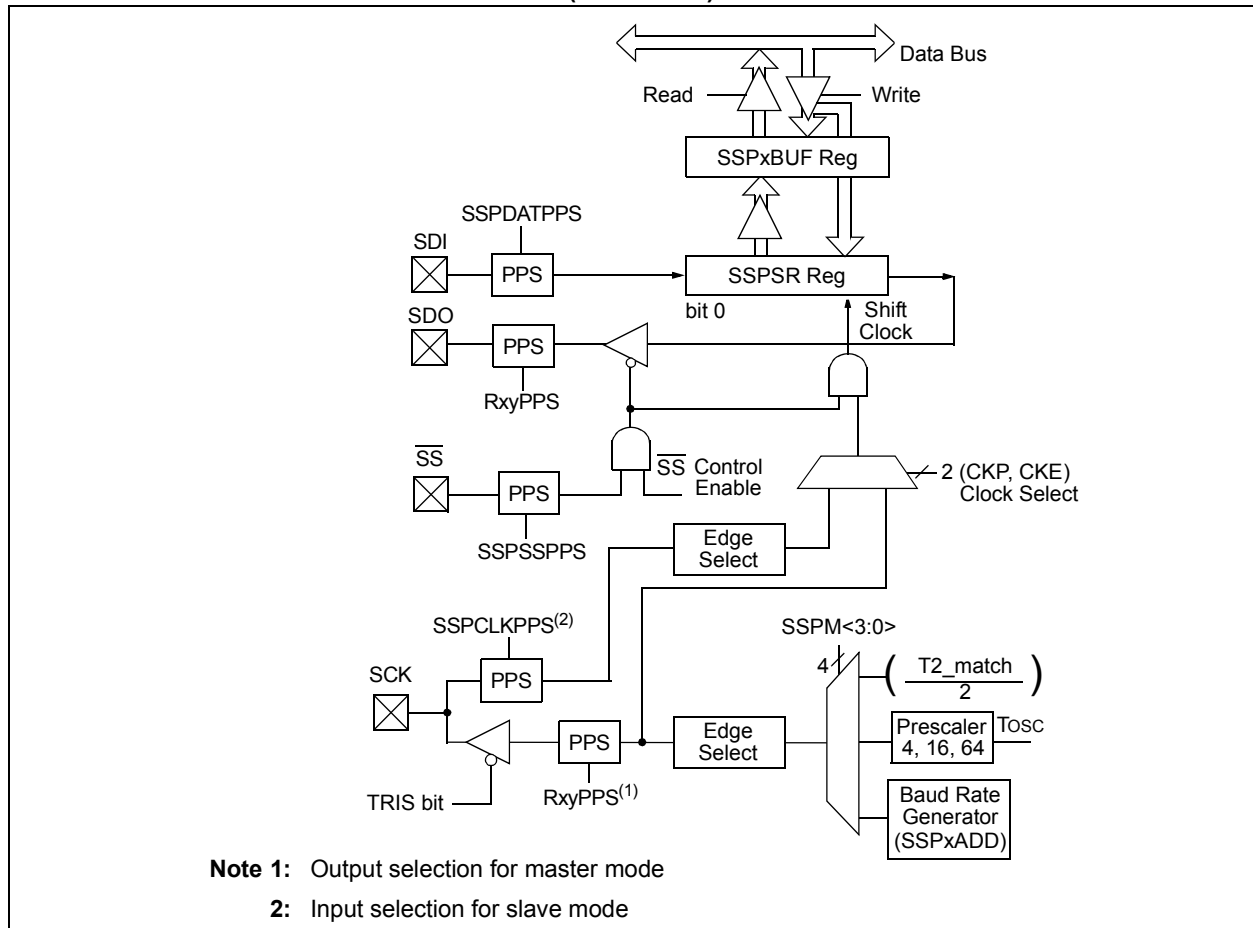

PIC16(L)F18856/76

The I²C interface supports the following modes and features:

- Master mode
- Slave mode
- Byte NACKing (Slave mode)
- Limited multi-master support
- 7-bit and 10-bit addressing
- Start and Stop interrupts
- Interrupt masking
- Clock stretching
- Bus collision detection
- General call address matching
- Address masking
- Address Hold and Data Hold modes
- Selectable SDA hold times

Figure 31-2 is a block diagram of the I²C interface module in Master mode. Figure 31-3 is a diagram of the I²C interface module in Slave mode.

Note 1: In devices with more than one MSSP module, it is very important to pay close attention to SSPxCONx register names. SSPxCON1 and SSPxCON2 registers control different operational aspects of the same module, while SSPxCON1 and SSP2CON1 control the same features for two different modules.

2: Throughout this section, generic references to an MSSPx module in any of its operating modes may be interpreted as being equally applicable to MSSPx or MSSP2. Register names, module I/O signals, and bit names may use the generic designator 'x' to indicate the use of a numeral to distinguish a particular module when required.

FIGURE 31-2: MSSP BLOCK DIAGRAM (I²C MASTER MODE)

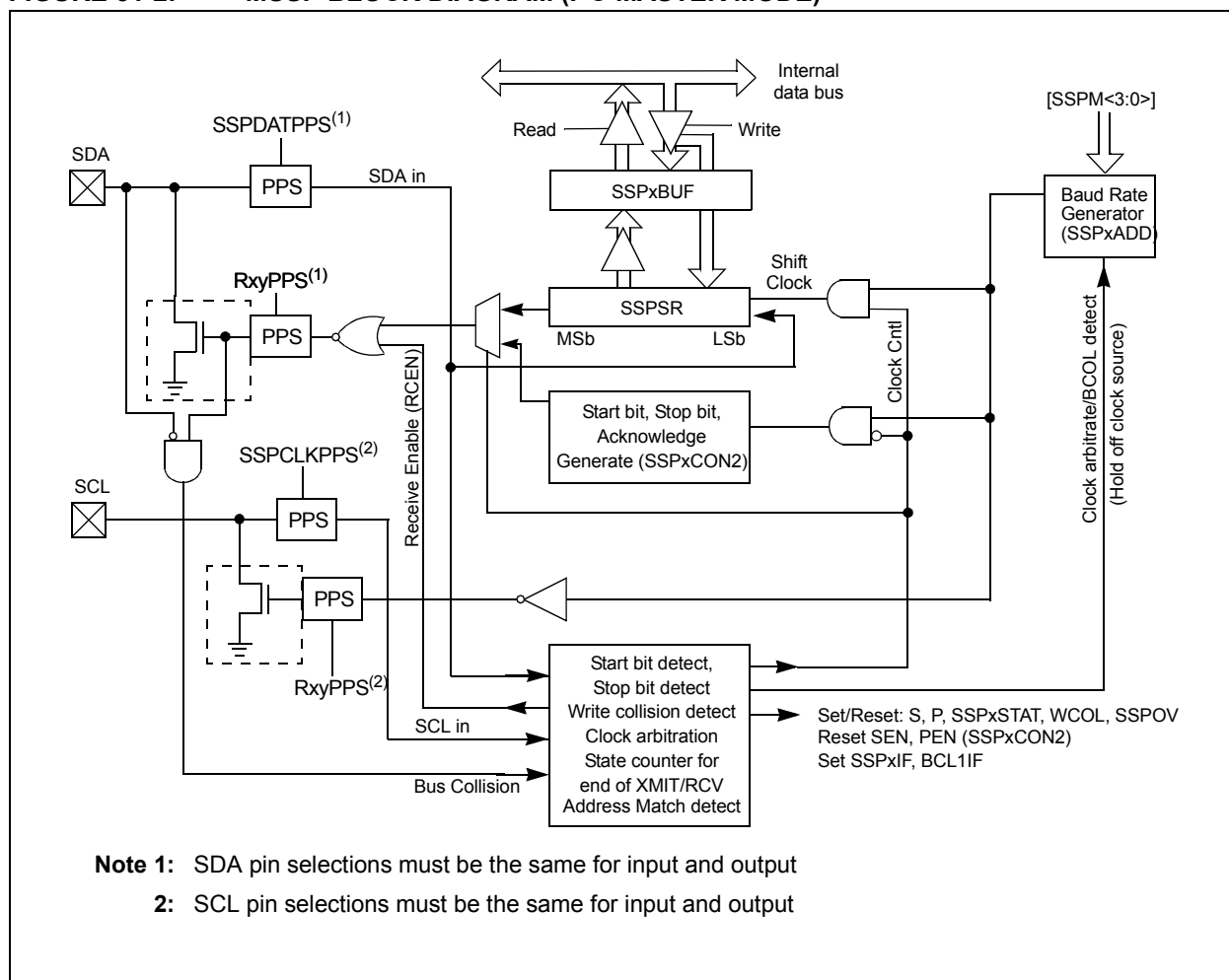

PIC16(L)F18856/76

FIGURE 31-3: MSSP BLOCK DIAGRAM (I²C SLAVE MODE)

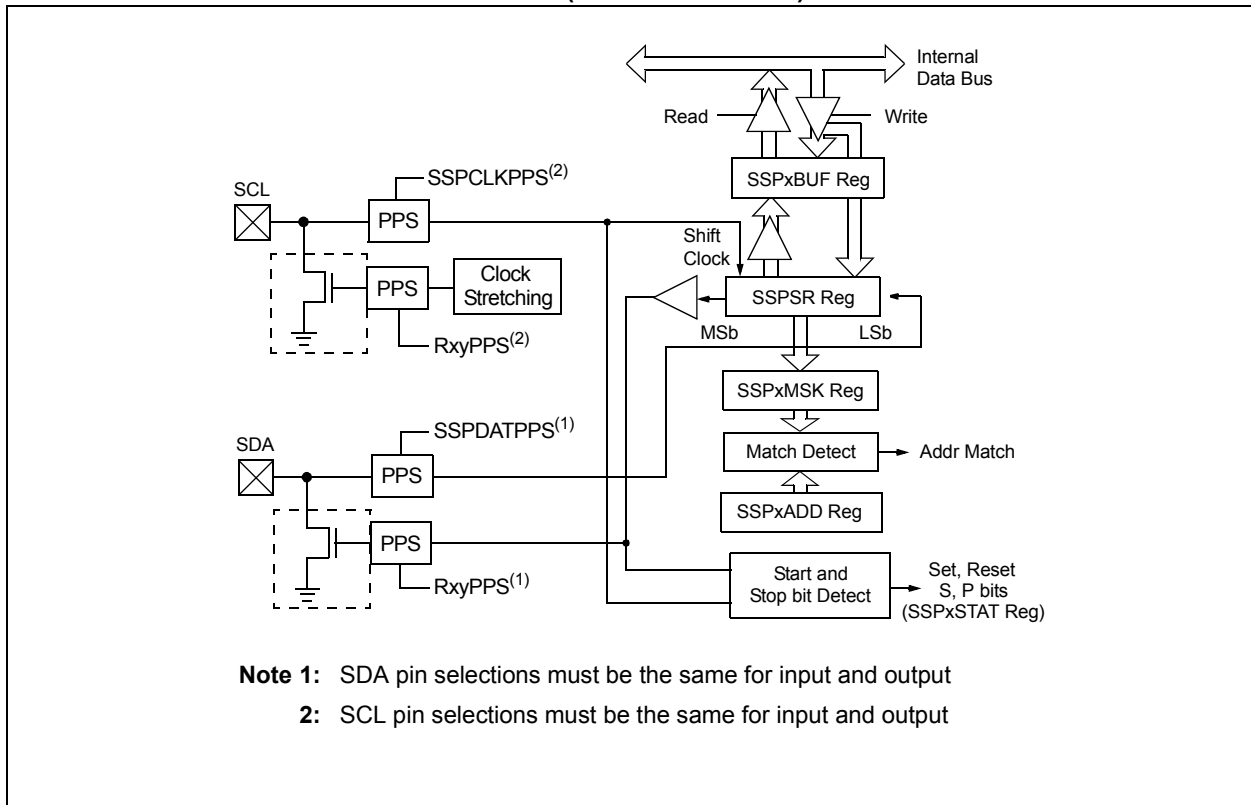

31.2 SPI Mode Overview

The Serial Peripheral Interface (SPI) bus is a synchronous serial data communication bus that operates in Full-Duplex mode. Devices communicate in a master/slave environment where the master device initiates the communication. A slave device is controlled through a Chip Select known as Slave Select.

The SPI bus specifies four signal connections:

- Serial Clock (SCK)
- Serial Data Out (SDO)
- Serial Data In (SDI)
- Slave Select (\overline{SS})

Figure 31-1 shows the block diagram of the MSSP module when operating in SPI mode.

The SPI bus operates with a single master device and one or more slave devices. When multiple slave devices are used, an independent Slave Select connection is required from the master device to each slave device.

Figure 31-4 shows a typical connection between a master device and multiple slave devices.

The master selects only one slave at a time. Most slave devices have tri-state outputs so their output signal appears disconnected from the bus when they are not selected.

Transmissions involve two shift registers, eight bits in size, one in the master and one in the slave. With either the master or the slave device, data is always shifted out one bit at a time, with the Most Significant bit (MSb) shifted out first. At the same time, a new Least Significant bit (LSb) is shifted into the same register.

Figure 31-5 shows a typical connection between two processors configured as master and slave devices.

Data is shifted out of both shift registers on the programmed clock edge and latched on the opposite edge of the clock.

The master device transmits information out on its SDO output pin which is connected to, and received by, the slave's SDI input pin. The slave device transmits information out on its SDO output pin, which is connected to, and received by, the master's SDI input pin.

To begin communication, the master device first sends out the clock signal. Both the master and the slave devices should be configured for the same clock polarity.

The master device starts a transmission by sending out the MSb from its shift register. The slave device reads this bit from that same line and saves it into the LSb position of its shift register.

During each SPI clock cycle, a full-duplex data transmission occurs. This means that while the master device is sending out the MSb from its shift register (on its SDO pin) and the slave device is reading this bit and saving it as the LSb of its shift register, that the slave device is also sending out the MSb from its shift register (on its SDO pin) and the master device is reading this bit and saving it as the LSb of its shift register.

After eight bits have been shifted out, the master and slave have exchanged register values.

If there is more data to exchange, the shift registers are loaded with new data and the process repeats itself.

Whether the data is meaningful or not (dummy data), depends on the application software. This leads to three scenarios for data transmission:

- Master sends useful data and slave sends dummy data.
- Master sends useful data and slave sends useful data.
- Master sends dummy data and slave sends useful data.

Transmissions may involve any number of clock cycles. When there is no more data to be transmitted, the master stops sending the clock signal and it deselects the slave.

Every slave device connected to the bus that has not been selected through its slave select line must disregard the clock and transmission signals and must not transmit out any data of its own.

PIC16(L)F18856/76

FIGURE 31-4: SPI MASTER AND MULTIPLE SLAVE CONNECTION

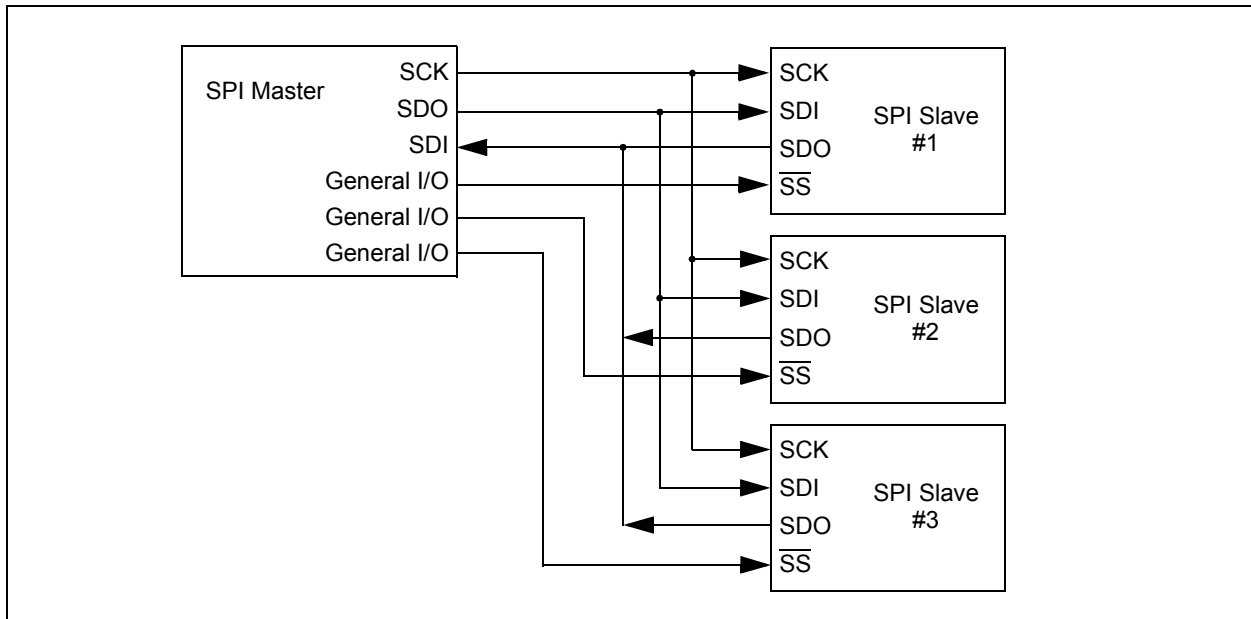

31.2.1 SPI MODE REGISTERS

The MSSP module has five registers for SPI mode operation. These are:

- MSSP STATUS register (SSPxSTAT)
- MSSP Control register 1 (SSPxCON1)
- MSSP Control register 3 (SSPxCON3)
- MSSP Data Buffer register (SSPxBUF)
- MSSP Address register (SSPxADD)
- MSSP Shift register (SSPxSR)
(Not directly accessible)

SSPxCON1 and SSPxSTAT are the control and status registers in SPI mode operation. The SSPxCON1 register is readable and writable. The lower six bits of the SSPxSTAT are read-only. The upper two bits of the SSPxSTAT are read/write.

In one SPI master mode, SSPxADD can be loaded with a value used in the Baud Rate Generator. More information on the Baud Rate Generator is available in [Section 31.7 “Baud Rate Generator”](#).

SSPxSR is the shift register used for shifting data in and out. SSPxBUF provides indirect access to the SSPxSR register. SSPxBUF is the buffer register to which data bytes are written, and from which data bytes are read.

In receive operations, SSPxSR and SSPxBUF together create a buffered receiver. When SSPxSR receives a complete byte, it is transferred to SSPxBUF and the SSPxIF interrupt is set.

During transmission, the SSPxBUF is not buffered. A write to SSPxBUF will write to both SSPxBUF and SSPxSR.

PIC16(L)F18856/76

31.2.2 SPI MODE OPERATION

When initializing the SPI, several options need to be specified. This is done by programming the appropriate control bits (SSPxCON1<3:0> and SSPxSTAT<7:6>). These control bits allow the following to be specified:

- Master mode (SCK is the clock output)
- Slave mode (SCK is the clock input)
- Clock Polarity (Idle state of SCK)
- Data Input Sample Phase (middle or end of data output time)
- Clock Edge (output data on rising/falling edge of SCK)
- Clock Rate (Master mode only)
- Slave Select mode (Slave mode only)

To enable the serial port, SSP Enable bit, SSPEN of the SSPxCON1 register, must be set. To reset or reconfigure SPI mode, clear the SSPEN bit, re-initialize the SSPxCONx registers and then set the SSPEN bit. This configures the SDI, SDO, SCK and \overline{SS} pins as serial port pins. For the pins to behave as the serial port function, some must have their data direction bits (in the TRISx register) appropriately programmed as follows:

- SDI must have corresponding TRIS bit set
- SDO must have corresponding TRIS bit cleared
- SCK (Master mode) must have corresponding TRIS bit cleared
- SCK (Slave mode) must have corresponding TRIS bit set
- \overline{SS} must have corresponding TRIS bit set

Any serial port function that is not desired may be overridden by programming the corresponding data direction (TRIS) register to the opposite value.

The MSSP consists of a transmit/receive shift register (SSPxSR) and a buffer register (SSPxBUF). The SSPxSR shifts the data in and out of the device, MSb first. The SSPxBUF holds the data that was written to the SSPxSR until the received data is ready. Once the eight bits of data have been received, that byte is moved to the SSPxBUF register. Then, the Buffer Full Detect bit, BF of the SSPxSTAT register, and the interrupt flag bit, SSPxIF, are set. This double-buffering of the received data (SSPxBUF) allows the next byte to start reception before reading the data that was just received. Any write to the SSPxBUF register during transmission/reception of data will be ignored and the write collision detect bit WCOL of the SSPxCON1 register, will be set. User software must clear the WCOL bit to allow the following write(s) to the SSPxBUF register to complete successfully.

When the application software is expecting to receive valid data, the SSPxBUF should be read before the next byte of data to transfer is written to the SSPxBUF. The Buffer Full bit, BF of the SSPxSTAT register, indicates when SSPxBUF has been loaded with the received data (transmission is complete). When the SSPxBUF is read, the BF bit is cleared. This data may be irrelevant if the SPI is only a transmitter. Generally, the MSSP interrupt is used to determine when the transmission/reception has completed. If the interrupt method is not going to be used, then software polling can be done to ensure that a write collision does not occur.

The SSPxSR is not directly readable or writable and can only be accessed by addressing the SSPxBUF register. Additionally, the SSPxSTAT register indicates the various Status conditions.

FIGURE 31-5: SPI MASTER/SLAVE CONNECTION

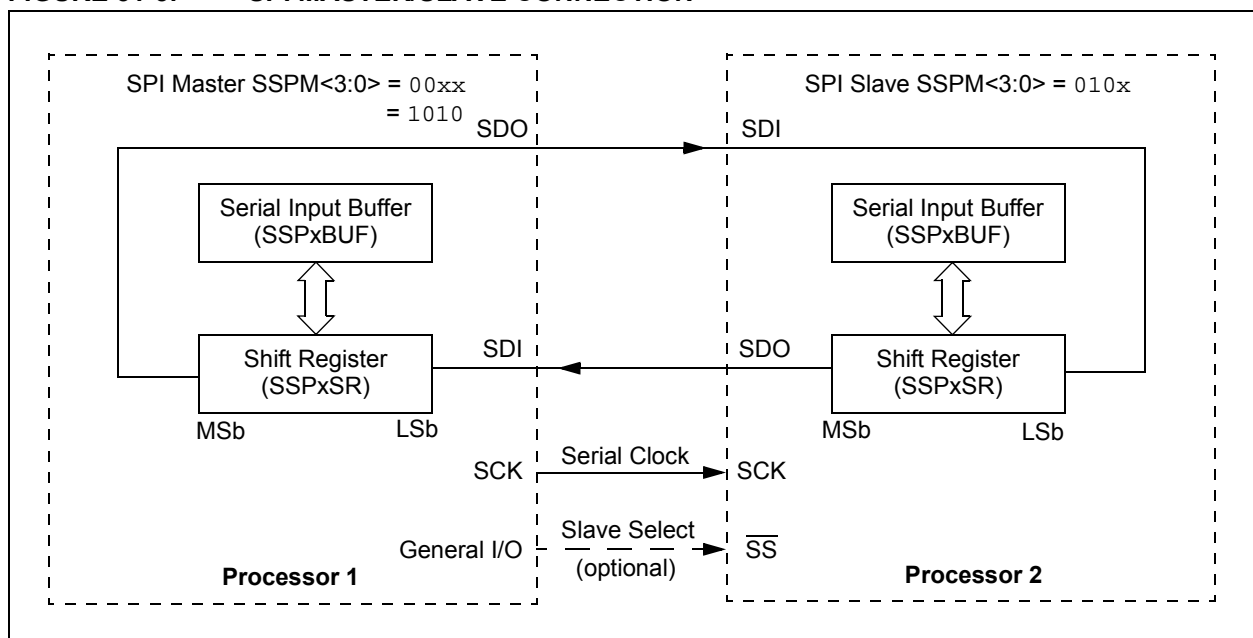

PIC16(L)F18856/76

31.2.3 SPI MASTER MODE

The master can initiate the data transfer at any time because it controls the SCK line. The master determines when the slave (Processor 2, [Figure 31-5](#)) is to broadcast data by the software protocol.

In Master mode, the data is transmitted/received as soon as the SSPxBUF register is written to. If the SPI is only going to receive, the SDO output could be disabled (programmed as an input). The SSPxSR register will continue to shift in the signal present on the SDI pin at the programmed clock rate. As each byte is received, it will be loaded into the SSPxBUF register as if a normal received byte (interrupts and Status bits appropriately set).

The clock polarity is selected by appropriately programming the CKP bit of the SSPxCON1 register and the CKE bit of the SSPxSTAT register. This then, would give waveforms for SPI communication as shown in [Figure 31-6](#), [Figure 31-8](#), [Figure 31-9](#) and [Figure 31-10](#), where the MSB is transmitted first. In Master mode, the SPI clock rate (bit rate) is user programmable to be one of the following:

- $F_{osc}/4$ (or T_{CY})
- $F_{osc}/16$ (or $4 * T_{CY}$)
- $F_{osc}/64$ (or $16 * T_{CY}$)
- Timer2 output/2
- $F_{osc}/(4 * (SSPxADD + 1))$

[Figure 31-6](#) shows the waveforms for Master mode.

When the CKE bit is set, the SDO data is valid before there is a clock edge on SCK. The change of the input sample is shown based on the state of the SMP bit. The time when the SSPxBUF is loaded with the received data is shown.

FIGURE 31-6: SPI MODE WAVEFORM (MASTER MODE)

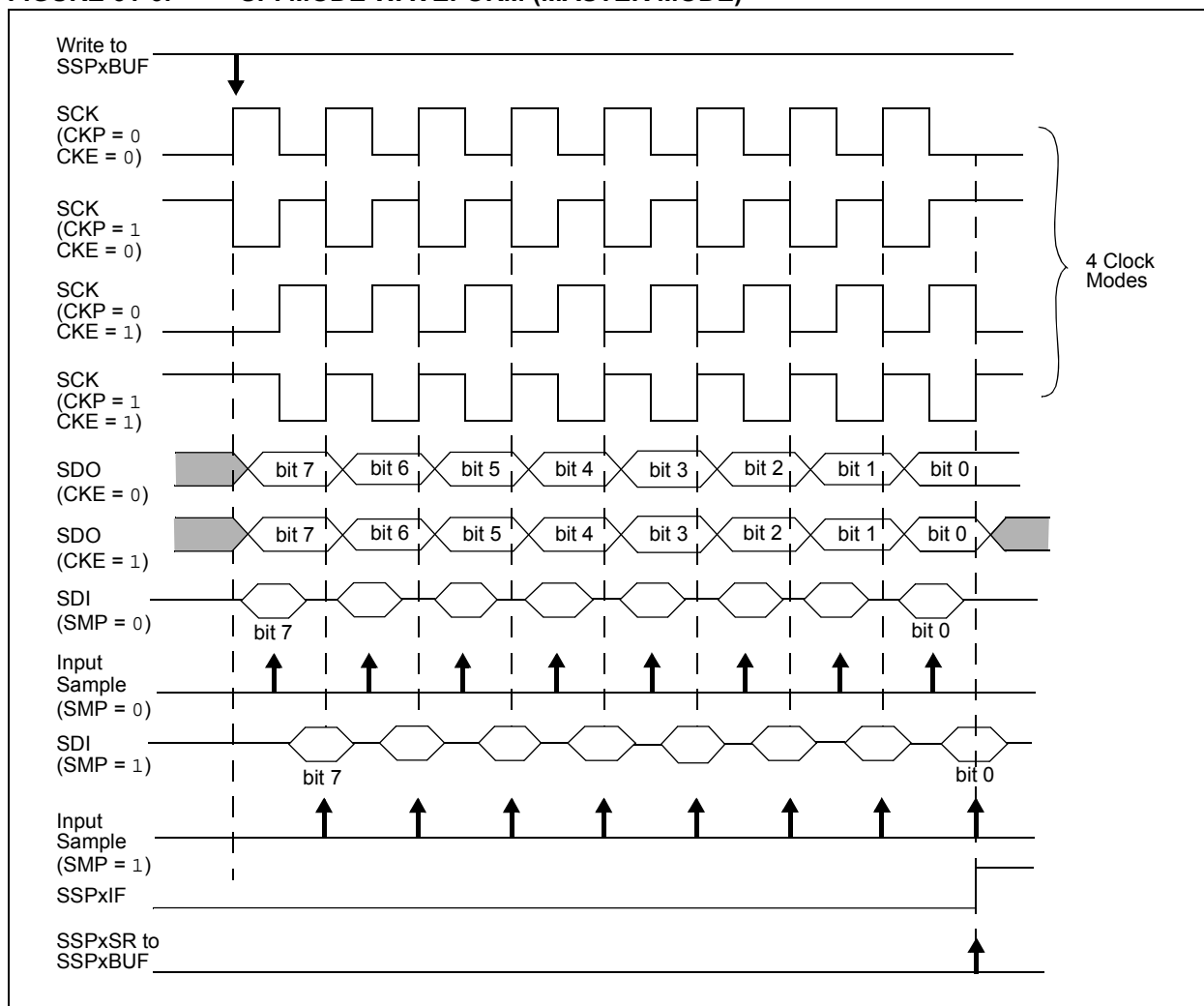

PIC16(L)F18856/76

31.2.4 SPI SLAVE MODE

In Slave mode, the data is transmitted and received as external clock pulses appear on SCK. When the last bit is latched, the SSPxIF interrupt flag bit is set.

Before enabling the module in SPI Slave mode, the clock line must match the proper Idle state. The clock line can be observed by reading the SCK pin. The Idle state is determined by the CKP bit of the SSPxCON1 register.

While in Slave mode, the external clock is supplied by the external clock source on the SCK pin. This external clock must meet the minimum high and low times as specified in the electrical specifications.

While in Sleep mode, the slave can transmit/receive data. The shift register is clocked from the SCK pin input and when a byte is received, the device will generate an interrupt. If enabled, the device will wake-up from Sleep.

31.2.4.1 Daisy-Chain Configuration

The SPI bus can sometimes be connected in a daisy-chain configuration. The first slave output is connected to the second slave input, the second slave output is connected to the third slave input, and so on. The final slave output is connected to the master input. Each slave sends out, during a second group of clock pulses, an exact copy of what was received during the first group of clock pulses. The whole chain acts as one large communication shift register. The daisy-chain feature only requires a single Slave Select line from the master device.

Figure 31-7 shows the block diagram of a typical daisy-chain connection when operating in SPI mode.

In a daisy-chain configuration, only the most recent byte on the bus is required by the slave. Setting the BOEN bit of the SSPxCON3 register will enable writes to the SSPxBUF register, even if the previous byte has not been read. This allows the software to ignore data that may not apply to it.

31.2.5 SLAVE SELECT SYNCHRONIZATION

The Slave Select can also be used to synchronize communication. The Slave Select line is held high until the master device is ready to communicate. When the Slave Select line is pulled low, the slave knows that a new transmission is starting.

If the slave fails to receive the communication properly, it will be reset at the end of the transmission, when the Slave Select line returns to a high state. The slave is then ready to receive a new transmission when the Slave Select line is pulled low again. If the Slave Select line is not used, there is a risk that the slave will eventually become out of sync with the master. If the slave misses a bit, it will always be one bit off in future transmissions. Use of the Slave Select line allows the slave and master to align themselves at the beginning of each transmission.

The \overline{SS} pin allows a Synchronous Slave mode. The SPI must be in Slave mode with \overline{SS} pin control enabled (SSPxCON1<3:0> = 0100).

When the \overline{SS} pin is low, transmission and reception are enabled and the SDO pin is driven.

When the \overline{SS} pin goes high, the SDO pin is no longer driven, even if in the middle of a transmitted byte and becomes a floating output. External pull-up/pull-down resistors may be desirable depending on the application.

- | |
|---|
| <p>Note 1: When the SPI is in Slave mode with \overline{SS} pin control enabled (SSPxCON1<3:0> = 0100), the SPI module will reset if the \overline{SS} pin is set to VDD.</p> <p>2: When the SPI is used in Slave mode with CKE set; the user must enable \overline{SS} pin control.</p> <p>3: While operated in SPI Slave mode the SMP bit of the SSPxSTAT register must remain clear.</p> |
|---|

When the SPI module resets, the bit counter is forced to '0'. This can be done by either forcing the \overline{SS} pin to a high level or clearing the SSPEN bit.

PIC16(L)F18856/76

FIGURE 31-7: SPI DAISY-CHAIN CONNECTION

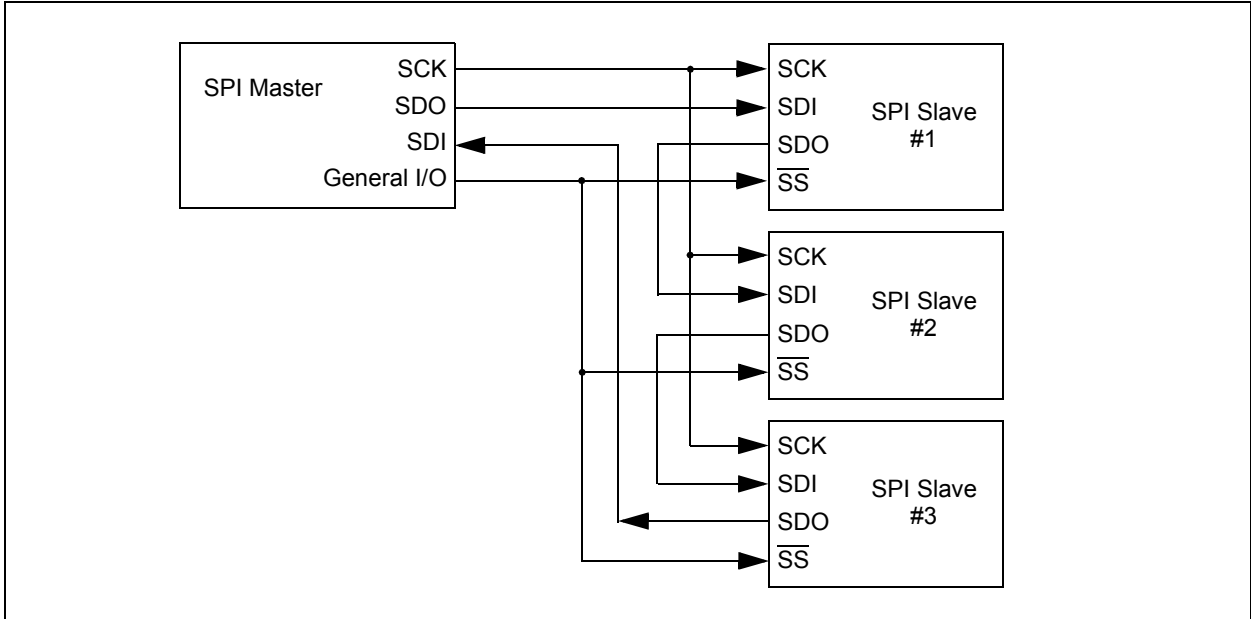
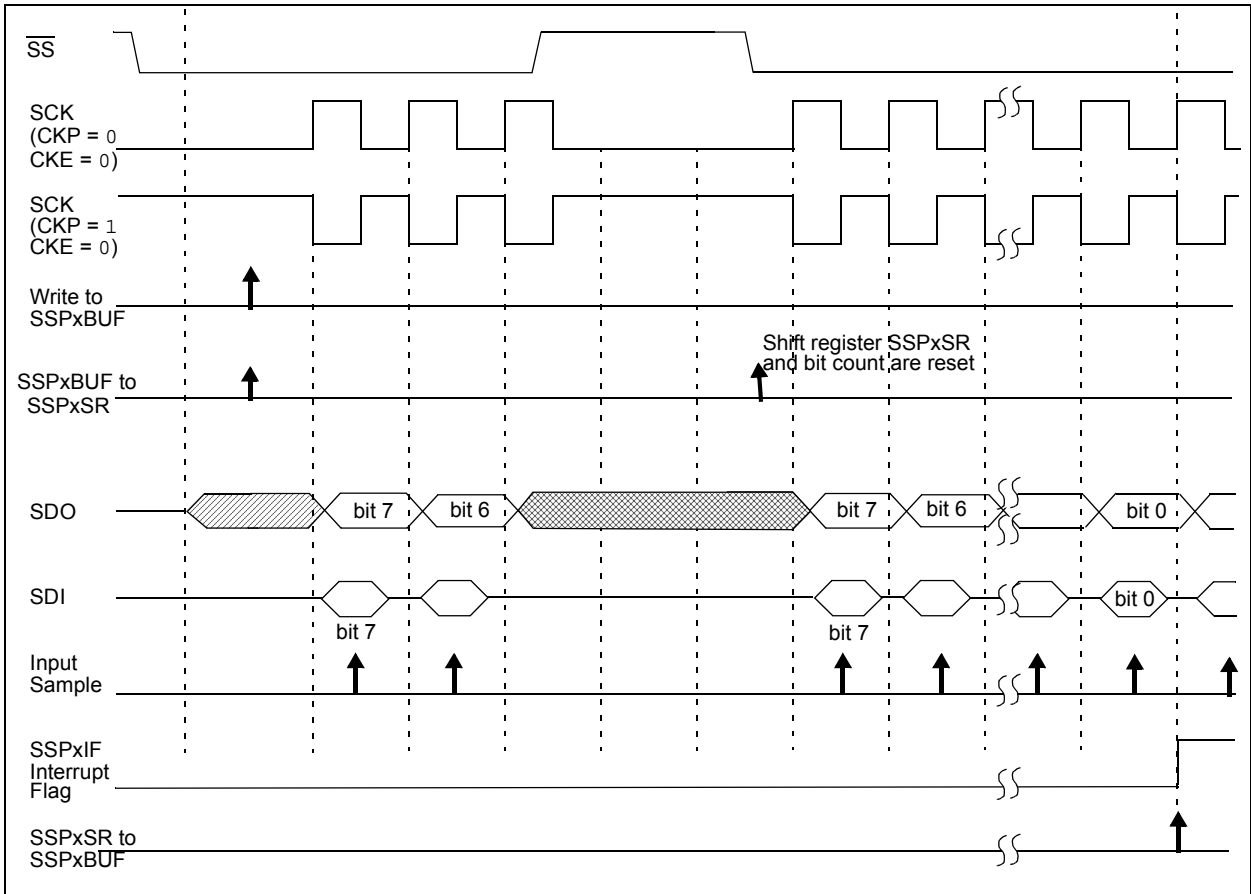

FIGURE 31-8: SLAVE SELECT SYNCHRONOUS WAVEFORM



PIC16(L)F18856/76

FIGURE 31-9: SPI MODE WAVEFORM (SLAVE MODE WITH CKE = 0)

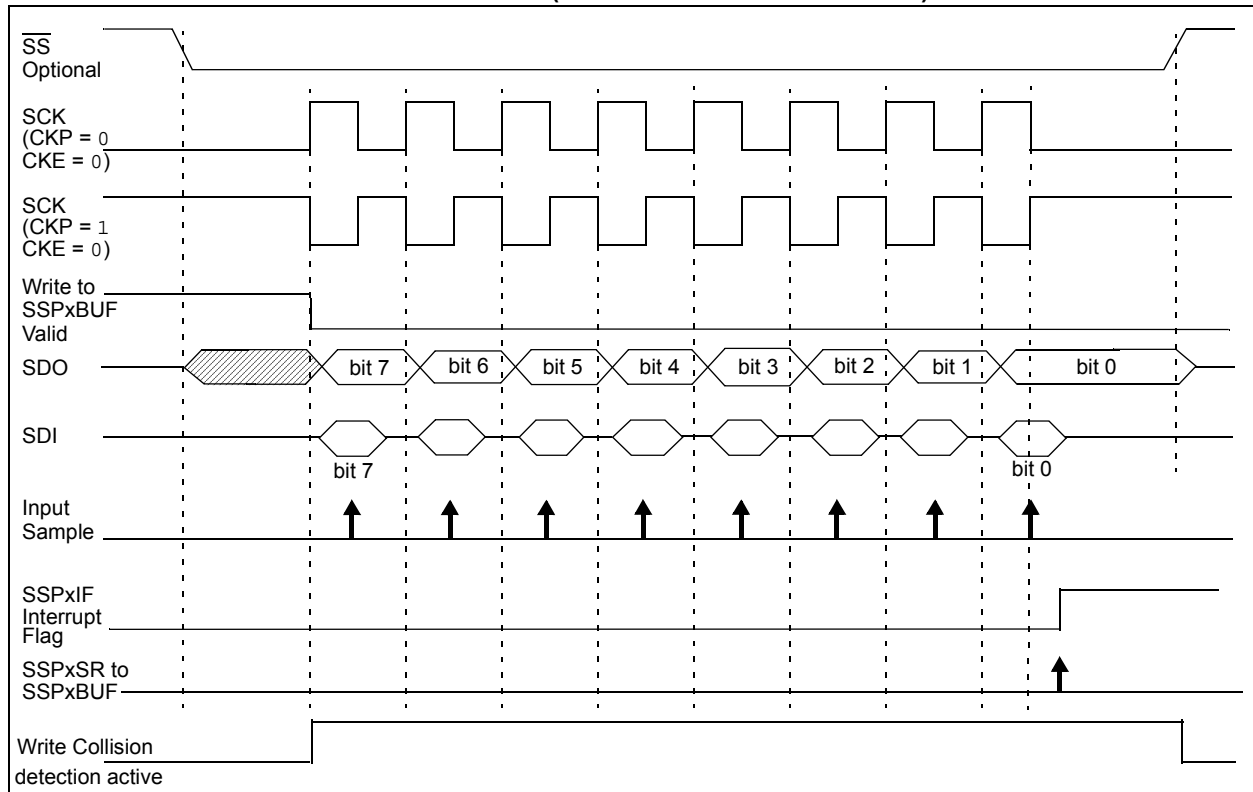
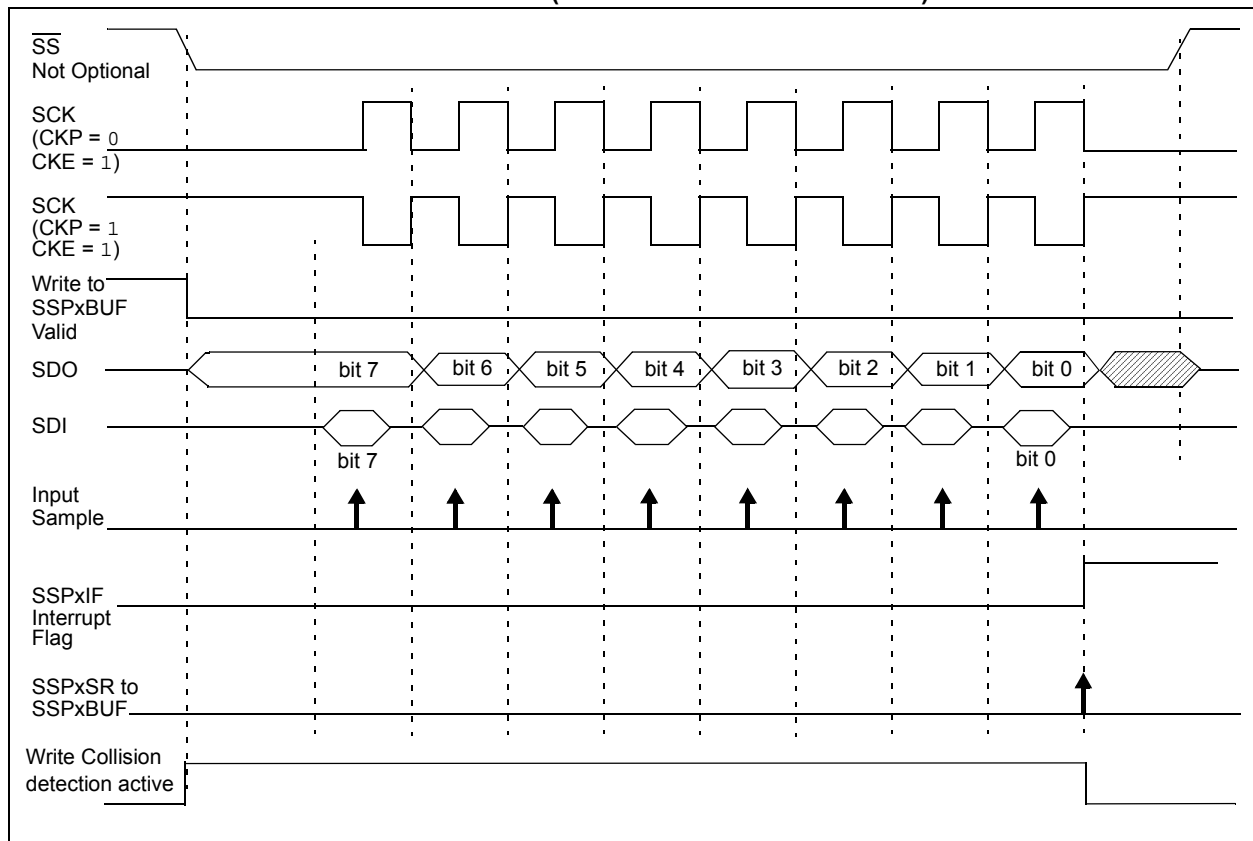

FIGURE 31-10: SPI MODE WAVEFORM (SLAVE MODE WITH CKE = 1)



PIC16(L)F18856/76

31.2.6 SPI OPERATION IN SLEEP MODE

In SPI Master mode, module clocks may be operating at a different speed than when in Full-Power mode; in the case of the Sleep mode, all clocks are halted.

Special care must be taken by the user when the MSSP clock is much faster than the system clock.

In Slave mode, when MSSP interrupts are enabled, after the master completes sending data, an MSSP interrupt will wake the controller from Sleep.

If an exit from Sleep mode is not desired, MSSP interrupts should be disabled.

In SPI Master mode, when the Sleep mode is selected, all module clocks are halted and the transmission/reception will remain in that state until the device wakes. After the device returns to Run mode, the module will resume transmitting and receiving data.

In SPI Slave mode, the SPI Transmit/Receive Shift register operates asynchronously to the device. This allows the device to be placed in Sleep mode and data to be shifted into the SPI Transmit/Receive Shift register. When all eight bits have been received, the MSSP interrupt flag bit will be set and if enabled, will wake the device.

31.3 I²C MODE OVERVIEW

The Inter-Integrated Circuit (I²C) bus is a multi-master serial data communication bus. Devices communicate in a master/slave environment where the master devices initiate the communication. A slave device is controlled through addressing.

The I²C bus specifies two signal connections:

- Serial Clock (SCL)
- Serial Data (SDA)

Figure 31-11 shows the block diagram of the MSSP module when operating in I²C mode.

Both the SCL and SDA connections are bidirectional open-drain lines, each requiring pull-up resistors for the supply voltage. Pulling the line to ground is considered a logical zero and letting the line float is considered a logical one.

Figure 31-11 shows a typical connection between two processors configured as master and slave devices.

The I²C bus can operate with one or more master devices and one or more slave devices.

There are four potential modes of operation for a given device:

- Master Transmit mode (master is transmitting data to a slave)
- Master Receive mode (master is receiving data from a slave)
- Slave Transmit mode (slave is transmitting data to a master)
- Slave Receive mode (slave is receiving data from the master)

To begin communication, a master device starts out in Master Transmit mode. The master device sends out a Start bit followed by the address byte of the slave it intends to communicate with. This is followed by a single Read/Write bit, which determines whether the master intends to transmit to or receive data from the slave device.

If the requested slave exists on the bus, it will respond with an Acknowledge bit, otherwise known as an ACK. The master then continues in either Transmit mode or Receive mode and the slave continues in the complement, either in Receive mode or Transmit mode, respectively.

A Start bit is indicated by a high-to-low transition of the SDA line while the SCL line is held high. Address and data bytes are sent out, Most Significant bit (MSb) first. The Read/Write bit is sent out as a logical one when the master intends to read data from the slave, and is sent out as a logical zero when it intends to write data to the slave.

FIGURE 31-11: I²C MASTER/SLAVE CONNECTION

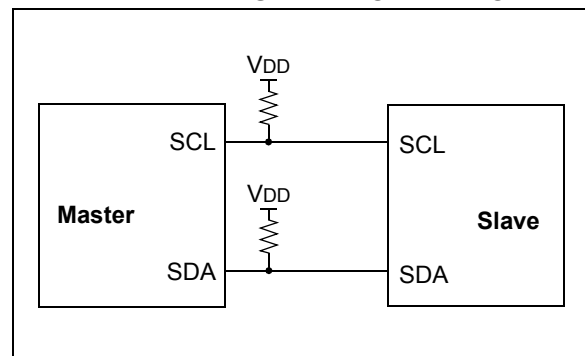

The Acknowledge bit ($\overline{\text{ACK}}$) is an active-low signal, which holds the SDA line low to indicate to the transmitter that the slave device has received the transmitted data and is ready to receive more.

The transition of a data bit is always performed while the SCL line is held low. Transitions that occur while the SCL line is held high are used to indicate Start and Stop bits.

PIC16(L)F18856/76

If the master intends to write to the slave, then it repeatedly sends out a byte of data, with the slave responding after each byte with an $\overline{\text{ACK}}$ bit. In this example, the master device is in Master Transmit mode and the slave is in Slave Receive mode.

If the master intends to read from the slave, then it repeatedly receives a byte of data from the slave, and responds after each byte with an $\overline{\text{ACK}}$ bit. In this example, the master device is in Master Receive mode and the slave is Slave Transmit mode.

On the last byte of data communicated, the master device may end the transmission by sending a Stop bit. If the master device is in Receive mode, it sends the Stop bit in place of the last $\overline{\text{ACK}}$ bit. A Stop bit is indicated by a low-to-high transition of the SDA line while the SCL line is held high.

In some cases, the master may want to maintain control of the bus and re-initiate another transmission. If so, the master device may send another Start bit in place of the Stop bit or last $\overline{\text{ACK}}$ bit when it is in receive mode.

The I²C bus specifies three message protocols;

- Single message where a master writes data to a slave.
- Single message where a master reads data from a slave.
- Combined message where a master initiates a minimum of two writes, or two reads, or a combination of writes and reads, to one or more slaves.

When one device is transmitting a logical one, or letting the line float, and a second device is transmitting a logical zero, or holding the line low, the first device can detect that the line is not a logical one. This detection, when used on the SCL line, is called clock stretching. Clock stretching gives slave devices a mechanism to control the flow of data. When this detection is used on the SDA line, it is called arbitration. Arbitration ensures that there is only one master device communicating at any single time.

31.3.1 CLOCK STRETCHING

When a slave device has not completed processing data, it can delay the transfer of more data through the process of clock stretching. An addressed slave device may hold the SCL clock line low after receiving or sending a bit, indicating that it is not yet ready to continue. The master that is communicating with the slave will attempt to raise the SCL line in order to transfer the next bit, but will detect that the clock line has not yet been released. Because the SCL connection is open-drain, the slave has the ability to hold that line low until it is ready to continue communicating.

Clock stretching allows receivers that cannot keep up with a transmitter to control the flow of incoming data.

31.3.2 ARBITRATION

Each master device must monitor the bus for Start and Stop bits. If the device detects that the bus is busy, it cannot begin a new message until the bus returns to an Idle state.

However, two master devices may try to initiate a transmission on or about the same time. When this occurs, the process of arbitration begins. Each transmitter checks the level of the SDA data line and compares it to the level that it expects to find. The first transmitter to observe that the two levels do not match, loses arbitration, and must stop transmitting on the SDA line.

For example, if one transmitter holds the SDA line to a logical one (lets it float) and a second transmitter holds it to a logical zero (pulls it low), the result is that the SDA line will be low. The first transmitter then observes that the level of the line is different than expected and concludes that another transmitter is communicating.

The first transmitter to notice this difference is the one that loses arbitration and must stop driving the SDA line. If this transmitter is also a master device, it also must stop driving the SCL line. It then can monitor the lines for a Stop condition before trying to reissue its transmission. In the meantime, the other device that has not noticed any difference between the expected and actual levels on the SDA line continues with its original transmission. It can do so without any complications, because so far, the transmission appears exactly as expected with no other transmitter disturbing the message.

Slave Transmit mode can also be arbitrated, when a master addresses multiple slaves, but this is less common.

If two master devices are sending a message to two different slave devices at the address stage, the master sending the lower slave address always wins arbitration. When two master devices send messages to the same slave address, and addresses can sometimes refer to multiple slaves, the arbitration process must continue into the data stage.

Arbitration usually occurs very rarely, but it is a necessary process for proper multi-master support.

PIC16(L)F18856/76

31.4 I²C MODE OPERATION

All MSSP I²C communication is byte oriented and shifted out MSb first. Six SFR registers and two interrupt flags interface the module with the PIC[®] microcontroller and user software. Two pins, SDA and SCL, are exercised by the module to communicate with other external I²C devices.

31.4.1 BYTE FORMAT

All communication in I²C is done in 9-bit segments. A byte is sent from a master to a slave or vice-versa, followed by an Acknowledge bit sent back. After the eighth falling edge of the SCL line, the device outputting data on the SDA changes that pin to an input and reads in an acknowledge value on the next clock pulse.

The clock signal, SCL, is provided by the master. Data is valid to change while the SCL signal is low, and sampled on the rising edge of the clock. Changes on the SDA line while the SCL line is high define special conditions on the bus, explained below.

31.4.2 DEFINITION OF I²C TERMINOLOGY

There is language and terminology in the description of I²C communication that have definitions specific to I²C. That word usage is defined below and may be used in the rest of this document without explanation. This table was adapted from the Philips I²C specification.

31.4.3 SDA AND SCL PINS

Selection of any I²C mode with the SSPEN bit set, forces the SCL and SDA pins to be open-drain. These pins should be set by the user to inputs by setting the appropriate TRIS bits.

Note 1: Data is tied to output zero when an I²C mode is enabled.

2: Any device pin can be selected for SDA and SCL functions with the PPS peripheral. These functions are bidirectional. The SDA input is selected with the SSPDATPPS registers. The SCL input is selected with the SSPCLKPPS registers. Outputs are selected with the RxyPPS registers. It is the user's responsibility to make the selections so that both the input and the output for each function is on the same pin.

31.4.4 SDA HOLD TIME

The hold time of the SDA pin is selected by the SDAHT bit of the SSPxCON3 register. Hold time is the time SDA is held valid after the falling edge of SCL. Setting the SDAHT bit selects a longer 300 ns minimum hold time and may help on buses with large capacitance.

TABLE 31-1: I²C BUS TERMS

TERM	Description
Transmitter	The device which shifts data out onto the bus.
Receiver	The device which shifts data in from the bus.
Master	The device that initiates a transfer, generates clock signals and terminates a transfer.
Slave	The device addressed by the master.
Multi-master	A bus with more than one device that can initiate data transfers.
Arbitration	Procedure to ensure that only one master at a time controls the bus. Winning arbitration ensures that the message is not corrupted.
Synchronization	Procedure to synchronize the clocks of two or more devices on the bus.
Idle	No master is controlling the bus, and both SDA and SCL lines are high.
Active	Any time one or more master devices are controlling the bus.
Addressed Slave	Slave device that has received a matching address and is actively being clocked by a master.
Matching Address	Address byte that is clocked into a slave that matches the value stored in SSPxADD.
Write Request	Slave receives a matching address with R/W bit clear, and is ready to clock in data.
Read Request	Master sends an address byte with the R/W bit set, indicating that it wishes to clock data out of the Slave. This data is the next and all following bytes until a Restart or Stop.
Clock Stretching	When a device on the bus hold SCL low to stall communication.
Bus Collision	Any time the SDA line is sampled low by the module while it is outputting and expected high state.

PIC16(L)F18856/76

31.4.5 START CONDITION

The I²C specification defines a Start condition as a transition of SDA from a high to a low state while SCL line is high. A Start condition is always generated by the master and signifies the transition of the bus from an Idle to an Active state. Figure 31-12 shows wave forms for Start and Stop conditions.

A bus collision can occur on a Start condition if the module samples the SDA line low before asserting it low. This does not conform to the I²C Specification that states no bus collision can occur on a Start.

31.4.6 STOP CONDITION

A Stop condition is a transition of the SDA line from low-to-high state while the SCL line is high.

Note: At least one SCL low time must appear before a Stop is valid, therefore, if the SDA line goes low then high again while the SCL line stays high, only the Start condition is detected.

31.4.7 RESTART CONDITION

A Restart is valid any time that a Stop would be valid. A master can issue a Restart if it wishes to hold the bus after terminating the current transfer. A Restart has the same effect on the slave that a Start would, resetting all slave logic and preparing it to clock in an address. The master may want to address the same or another slave. Figure 31-13 shows the wave form for a Restart condition.

In 10-bit Addressing Slave mode a Restart is required for the master to clock data out of the addressed slave. Once a slave has been fully addressed, matching both high and low address bytes, the master can issue a Restart and the high address byte with the R/W bit set. The slave logic will then hold the clock and prepare to clock out data.

After a full match with R/W clear in 10-bit mode, a prior match flag is set and maintained until a Stop condition, a high address with R/W clear, or high address match fails.

31.4.8 START/STOP CONDITION INTERRUPT MASKING

The SCIE and PCIE bits of the SSPxCON3 register can enable the generation of an interrupt in Slave modes that do not typically support this function. Slave modes where interrupt on Start and Stop detect are already enabled, these bits will have no effect.

FIGURE 31-12: I²C START AND STOP CONDITIONS

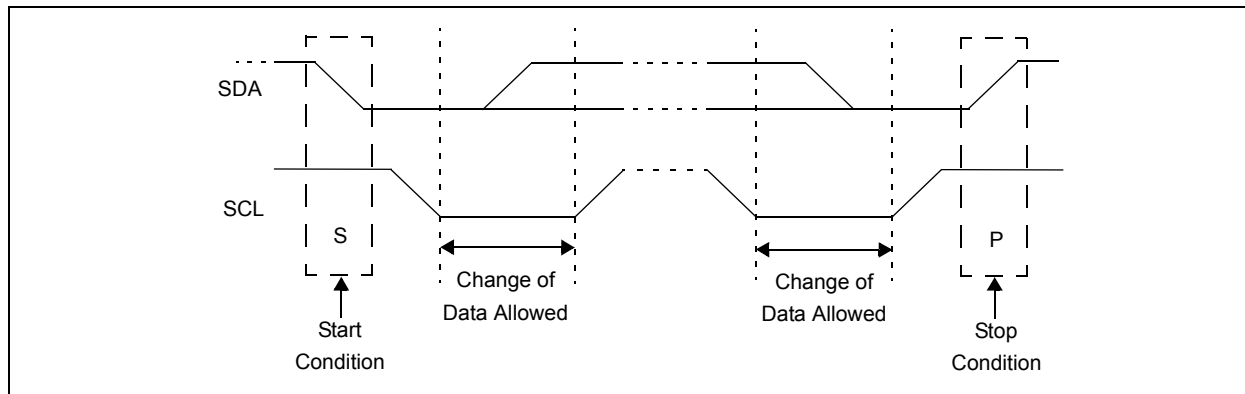
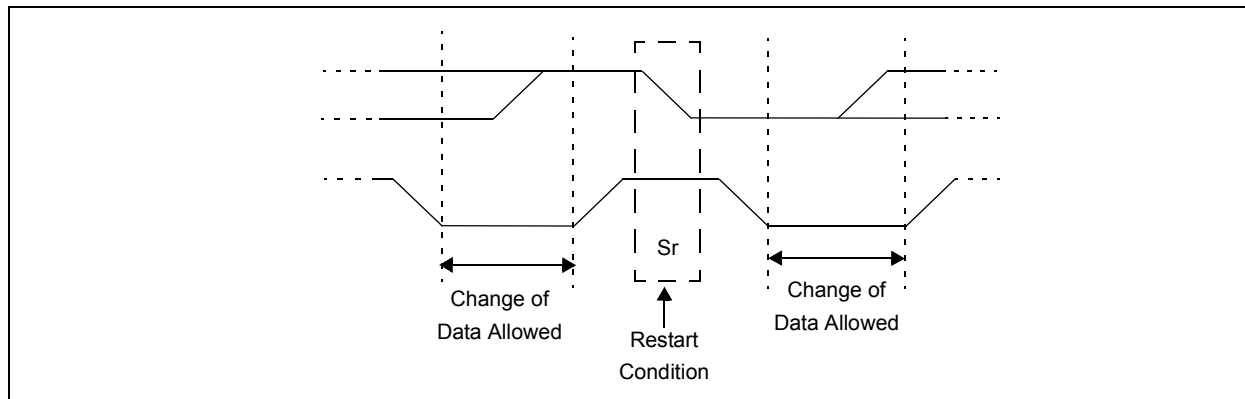

FIGURE 31-13: I²C RESTART CONDITION



31.4.9 ACKNOWLEDGE SEQUENCE

The 9th SCL pulse for any transferred byte in I²C is dedicated as an Acknowledge. It allows receiving devices to respond back to the transmitter by pulling the SDA line low. The transmitter must release control of the line during this time to shift in the response. The Acknowledge ($\overline{\text{ACK}}$) is an active-low signal, pulling the SDA line low indicates to the transmitter that the device has received the transmitted data and is ready to receive more.

The result of an $\overline{\text{ACK}}$ is placed in the ACKSTAT bit of the SSPxCON2 register.

Slave software, when the AHEN and DHEN bits are set, allow the user to set the $\overline{\text{ACK}}$ value sent back to the transmitter. The ACKDT bit of the SSPxCON2 register is set/cleared to determine the response.

Slave hardware will generate an $\overline{\text{ACK}}$ response if the AHEN and DHEN bits of the SSPxCON3 register are clear.

There are certain conditions where an $\overline{\text{ACK}}$ will not be sent by the slave. If the BF bit of the SSPxSTAT register or the SSPOV bit of the SSPxCON1 register are set when a byte is received.

When the module is addressed, after the eighth falling edge of SCL on the bus, the ACKTIM bit of the SSPxCON3 register is set. The ACKTIM bit indicates the acknowledge time of the active bus. The ACKTIM Status bit is only active when the AHEN bit or DHEN bit is enabled.

31.5 I²C SLAVE MODE OPERATION

The MSSP Slave mode operates in one of four modes selected by the SSPM bits of SSPxCON1 register. The modes can be divided into 7-bit and 10-bit Addressing mode. 10-bit Addressing modes operate the same as 7-bit with some additional overhead for handling the larger addresses.

Modes with Start and Stop bit interrupts operate the same as the other modes with SSPxIF additionally getting set upon detection of a Start, Restart, or Stop condition.

31.5.1 SLAVE MODE ADDRESSES

The SSPxADD register ([Register 31-6](#)) contains the Slave mode address. The first byte received after a Start or Restart condition is compared against the value stored in this register. If the byte matches, the value is loaded into the SSPxBUF register and an interrupt is generated. If the value does not match, the module goes idle and no indication is given to the software that anything happened.

The SSP Mask register ([Register 31-5](#)) affects the address matching process. See [Section 31.5.9 “SSP Mask Register”](#) for more information.

31.5.1.1 I²C Slave 7-bit Addressing Mode

In 7-bit Addressing mode, the LSB of the received data byte is ignored when determining if there is an address match.

31.5.1.2 I²C Slave 10-bit Addressing Mode

In 10-bit Addressing mode, the first received byte is compared to the binary value of '1 1 1 1 0 A9 A8 0'. A9 and A8 are the two MSb's of the 10-bit address and stored in bits 2 and 1 of the SSPxADD register.

After the acknowledge of the high byte the UA bit is set and SCL is held low until the user updates SSPxADD with the low address. The low address byte is clocked in and all eight bits are compared to the low address value in SSPxADD. Even if there is not an address match; SSPxIF and UA are set, and SCL is held low until SSPxADD is updated to receive a high byte again. When SSPxADD is updated the UA bit is cleared. This ensures the module is ready to receive the high address byte on the next communication.

A high and low address match as a write request is required at the start of all 10-bit addressing communication. A transmission can be initiated by issuing a Restart once the slave is addressed, and clocking in the high address with the R/W bit set. The slave hardware will then acknowledge the read request and prepare to clock out data. This is only valid for a slave after it has received a complete high and low address byte match.

PIC16(L)F18856/76

31.5.2 SLAVE RECEPTION

When the $\overline{R/W}$ bit of a matching received address byte is clear, the $\overline{R/W}$ bit of the SSPxSTAT register is cleared. The received address is loaded into the SSPxBUF register and acknowledged.

When the overflow condition exists for a received address, then not Acknowledge is given. An overflow condition is defined as either bit BF of the SSPxSTAT register is set, or bit SSPOV of the SSPxCON1 register is set. The BOEN bit of the SSPxCON3 register modifies this operation. For more information see [Register 31-4](#).

An MSSP interrupt is generated for each transferred data byte. Flag bit, SSPxIF, must be cleared by software.

When the SEN bit of the SSPxCON2 register is set, SCL will be held low (clock stretch) following each received byte. The clock must be released by setting the CKP bit of the SSPxCON1 register, except sometimes in 10-bit mode. See [Section 31.5.6.2 “10-bit Addressing Mode”](#) for more detail.

31.5.2.1 7-bit Addressing Reception

This section describes a standard sequence of events for the MSSP module configured as an I²C slave in 7-bit Addressing mode. [Figure 31-14](#) and [Figure 31-15](#) is used as a visual reference for this description.

This is a step by step process of what typically must be done to accomplish I²C communication.

1. Start bit detected.
2. S bit of SSPxSTAT is set; SSPxIF is set if interrupt on Start detect is enabled.
3. Matching address with $\overline{R/W}$ bit clear is received.
4. The slave pulls SDA low sending an \overline{ACK} to the master, and sets SSPxIF bit.
5. Software clears the SSPxIF bit.
6. Software reads received address from SSPxBUF clearing the BF flag.
7. If SEN = 1; Slave software sets CKP bit to release the SCL line.
8. The master clocks out a data byte.
9. Slave drives SDA low sending an \overline{ACK} to the master, and sets SSPxIF bit.
10. Software clears SSPxIF.
11. Software reads the received byte from SSPxBUF clearing BF.
12. Steps 8-12 are repeated for all received bytes from the master.
13. Master sends Stop condition, setting P bit of SSPxSTAT, and the bus goes idle.

31.5.2.2 7-bit Reception with AHEN and DHEN

Slave device reception with AHEN and DHEN set operate the same as without these options with extra interrupts and clock stretching added after the eighth falling edge of SCL. These additional interrupts allow the slave software to decide whether it wants to ACK the receive address or data byte, rather than the hardware. This functionality adds support for PMBus™ that was not present on previous versions of this module.

This list describes the steps that need to be taken by slave software to use these options for I²C communication. [Figure 31-16](#) displays a module using both address and data holding. [Figure 31-17](#) includes the operation with the SEN bit of the SSPxCON2 register set.

1. S bit of SSPxSTAT is set; SSPxIF is set if interrupt on Start detect is enabled.
2. Matching address with $\overline{R/W}$ bit clear is clocked in. SSPxIF is set and CKP cleared after the eighth falling edge of SCL.
3. Slave clears the SSPxIF.
4. Slave can look at the ACKTIM bit of the SSPxCON3 register to determine if the SSPxIF was after or before the \overline{ACK} .
5. Slave reads the address value from SSPxBUF, clearing the BF flag.
6. Slave sets \overline{ACK} value clocked out to the master by setting ACKDT.
7. Slave releases the clock by setting CKP.
8. SSPxIF is set after an \overline{ACK} , not after a NACK.
9. If SEN = 1 the slave hardware will stretch the clock after the \overline{ACK} .
10. Slave clears SSPxIF.

Note: SSPxIF is still set after the ninth falling edge of SCL even if there is no clock stretching and BF has been cleared. Only if NACK is sent to master is SSPxIF not set

11. SSPxIF set and CKP cleared after eighth falling edge of SCL for a received data byte.
12. Slave looks at ACKTIM bit of SSPxCON3 to determine the source of the interrupt.
13. Slave reads the received data from SSPxBUF clearing BF.
14. Steps 7-14 are the same for each received data byte.
15. Communication is ended by either the slave sending an \overline{ACK} = 1, or the master sending a Stop condition. If a Stop is sent and Interrupt on Stop Detect is disabled, the slave will only know by polling the P bit of the SSPxSTAT register.

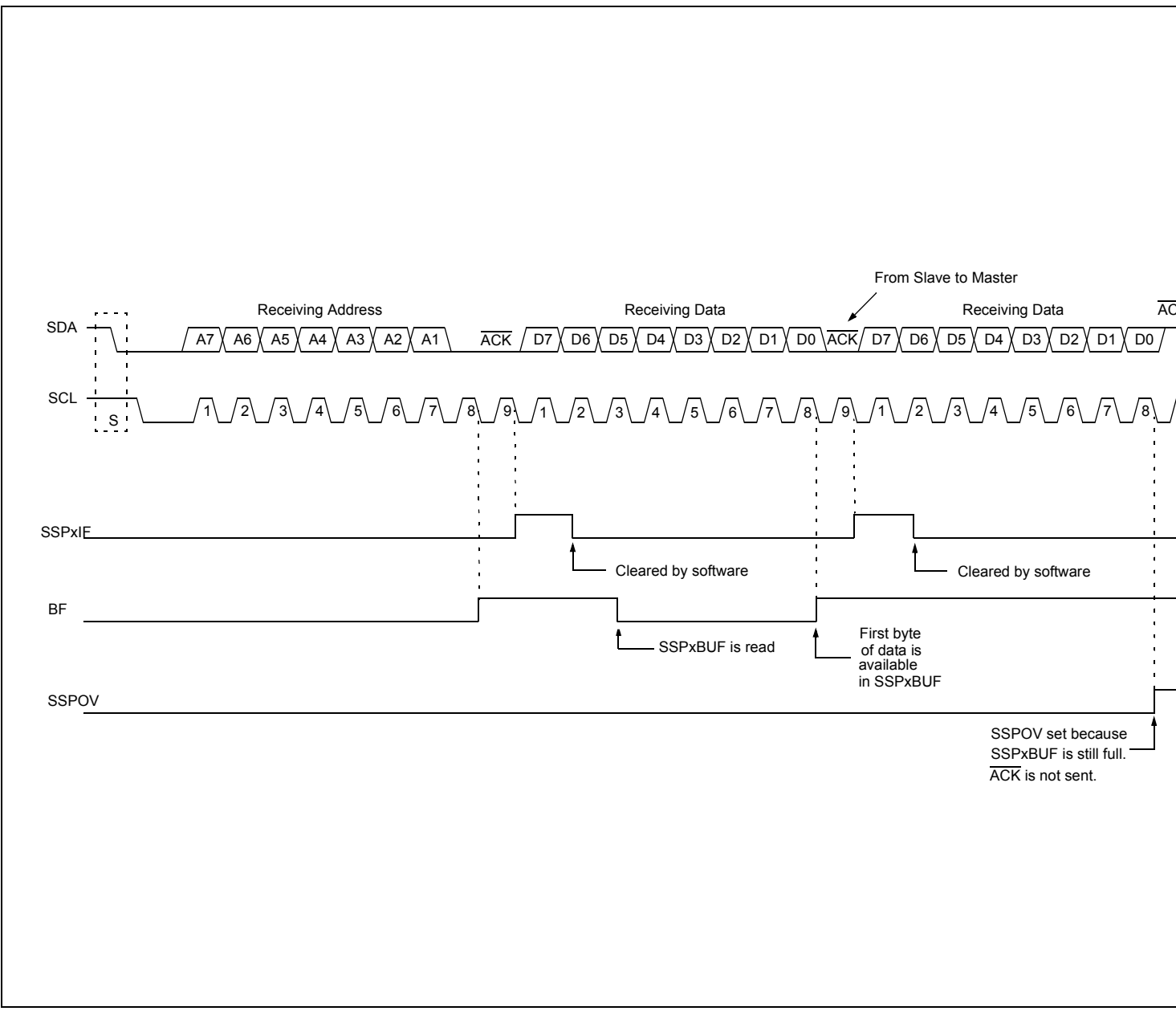

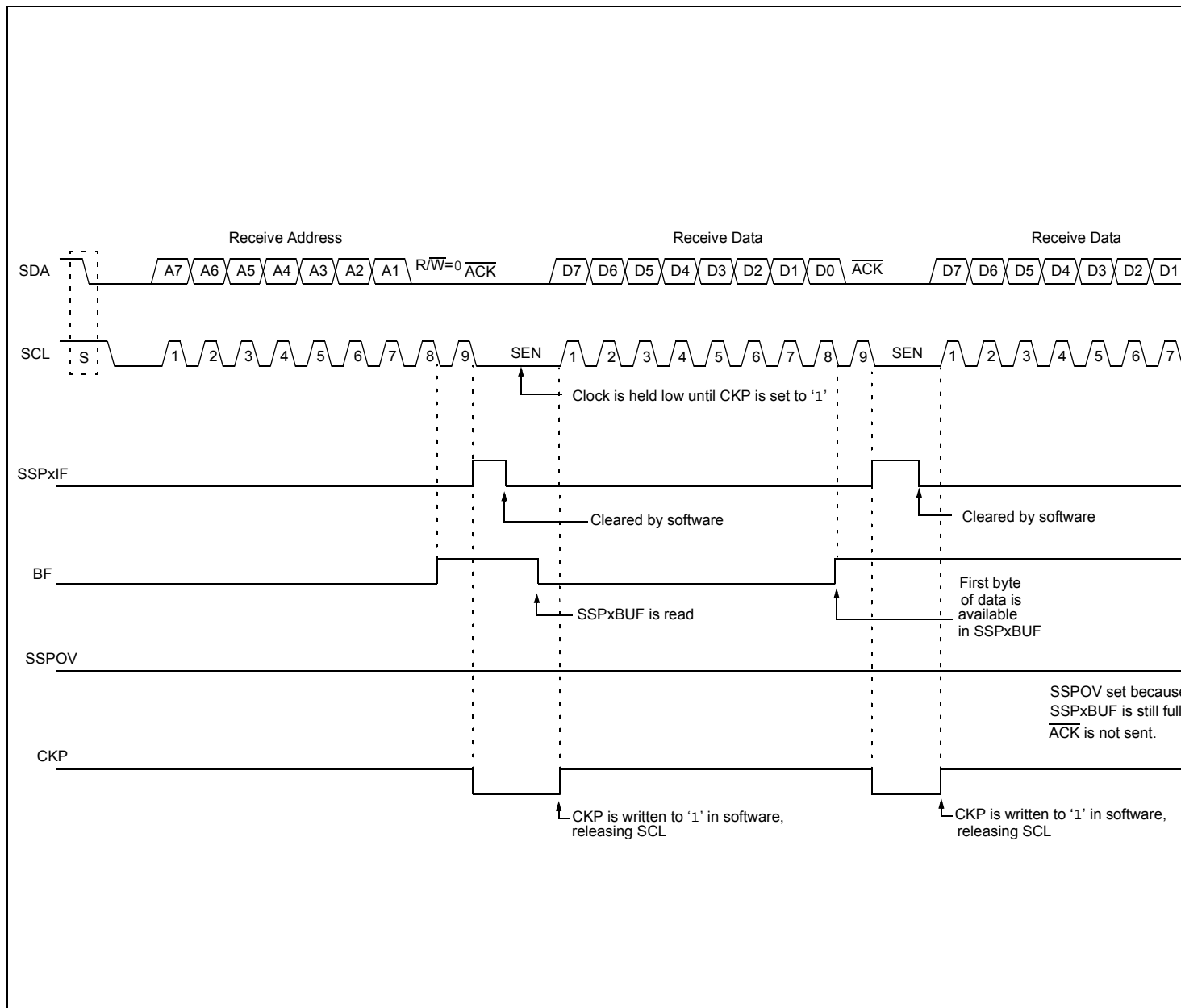

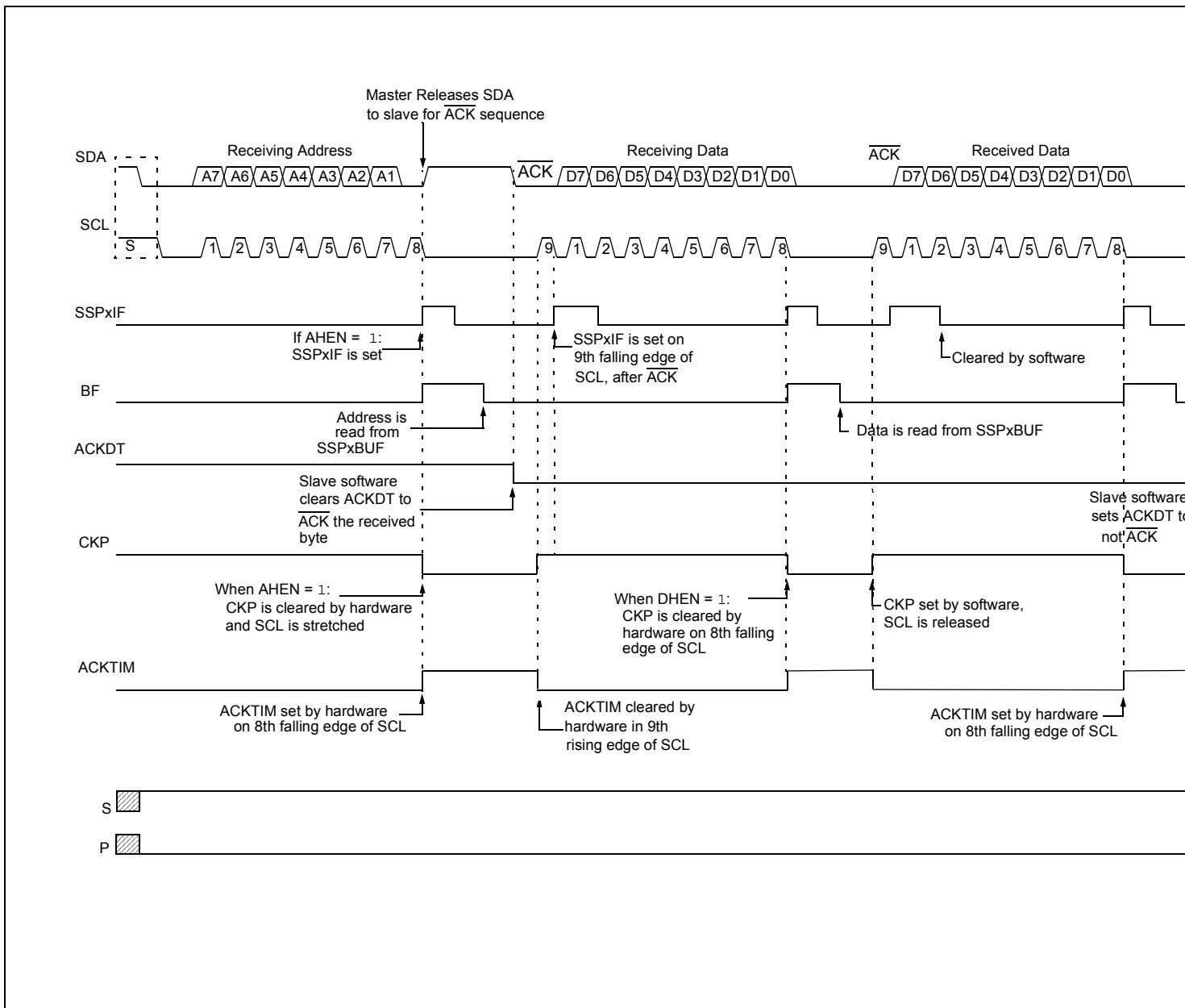

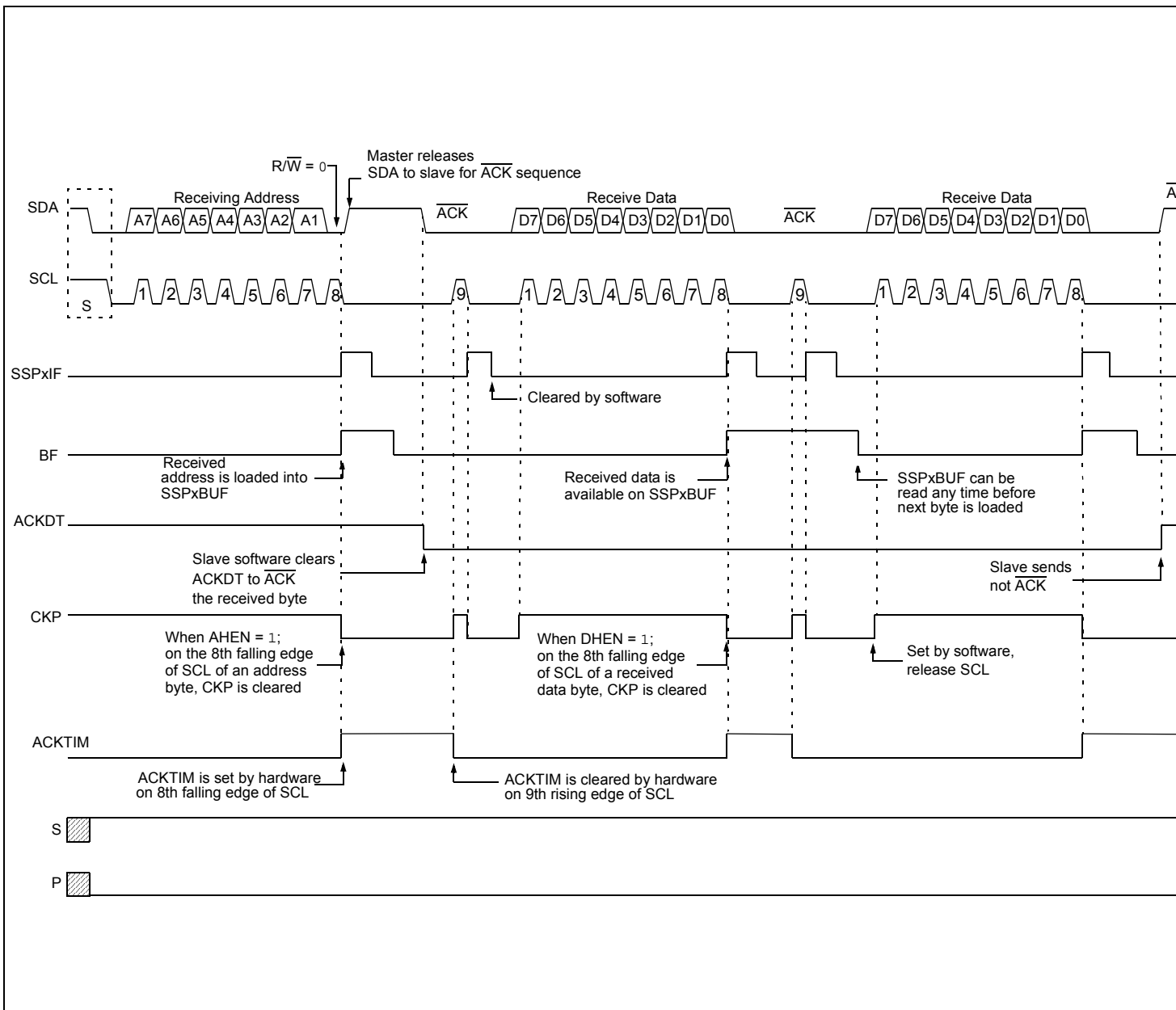

PIC16(L)F18856/76

31.5.3 SLAVE TRANSMISSION

When the $\overline{R/W}$ bit of the incoming address byte is set and an address match occurs, the $\overline{R/W}$ bit of the SSPxSTAT register is set. The received address is loaded into the SSPxBUF register, and an \overline{ACK} pulse is sent by the slave on the ninth bit.

Following the \overline{ACK} , slave hardware clears the CKP bit and the SCL pin is held low (see [Section 31.5.6 “Clock Stretching”](#) for more detail). By stretching the clock, the master will be unable to assert another clock pulse until the slave is done preparing the transmit data.

The transmit data must be loaded into the SSPxBUF register which also loads the SSPxSR register. Then the SCL pin should be released by setting the CKP bit of the SSPxCON1 register. The eight data bits are shifted out on the falling edge of the SCL input. This ensures that the SDA signal is valid during the SCL high time.

The \overline{ACK} pulse from the master-receiver is latched on the rising edge of the ninth SCL input pulse. This \overline{ACK} value is copied to the ACKSTAT bit of the SSPxCON2 register. If ACKSTAT is set (not \overline{ACK}), then the data transfer is complete. In this case, when the not \overline{ACK} is latched by the slave, the slave goes idle and waits for another occurrence of the Start bit. If the SDA line was low (\overline{ACK}), the next transmit data must be loaded into the SSPxBUF register. Again, the SCL pin must be released by setting bit CKP.

An MSSP interrupt is generated for each data transfer byte. The SSPxIF bit must be cleared by software and the SSPxSTAT register is used to determine the status of the byte. The SSPxIF bit is set on the falling edge of the ninth clock pulse.

31.5.3.1 Slave Mode Bus Collision

A slave receives a read request and begins shifting data out on the SDA line. If a bus collision is detected and the SBCDE bit of the SSPxCON3 register is set, the BCL1IF bit of the PIR3 register is set. Once a bus collision is detected, the slave goes idle and waits to be addressed again. User software can use the BCL1IF bit to handle a slave bus collision.

31.5.3.2 7-bit Transmission

A master device can transmit a read request to a slave, and then clock data out of the slave. The list below outlines what software for a slave will need to do to accomplish a standard transmission. [Figure 31-18](#) can be used as a reference to this list.

1. Master sends a Start condition on SDA and SCL.
2. S bit of SSPxSTAT is set; SSPxIF is set if interrupt on Start detect is enabled.
3. Matching address with $\overline{R/W}$ bit set is received by the Slave setting SSPxIF bit.
4. Slave hardware generates an \overline{ACK} and sets SSPxIF.
5. SSPxIF bit is cleared by user.
6. Software reads the received address from SSPxBUF, clearing BF.
7. $\overline{R/W}$ is set so CKP was automatically cleared after the \overline{ACK} .
8. The slave software loads the transmit data into SSPxBUF.
9. CKP bit is set releasing SCL, allowing the master to clock the data out of the slave.
10. SSPxIF is set after the \overline{ACK} response from the master is loaded into the ACKSTAT register.
11. SSPxIF bit is cleared.
12. The slave software checks the ACKSTAT bit to see if the master wants to clock out more data.

Note 1: If the master \overline{ACK} s the clock will be stretched.

2: ACKSTAT is the only bit updated on the rising edge of SCL (9th) rather than the falling.

13. Steps 9-13 are repeated for each transmitted byte.
14. If the master sends a not \overline{ACK} ; the clock is not held, but SSPxIF is still set.
15. The master sends a Restart condition or a Stop.
16. The slave is no longer addressed.

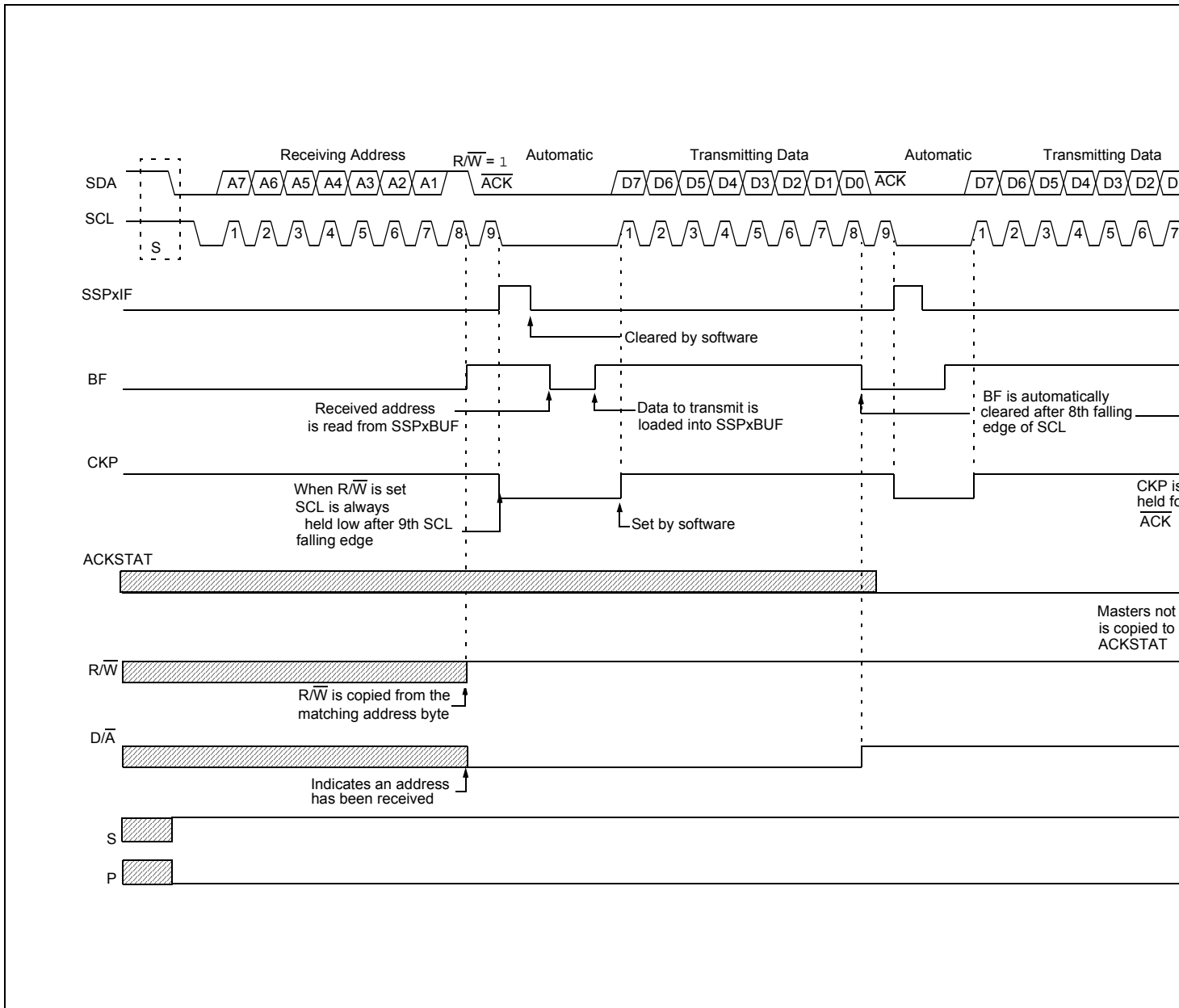

PIC16(L)F18856/76

31.5.3.3 7-bit Transmission with Address Hold Enabled

Setting the AHEN bit of the SSPxCON3 register enables additional clock stretching and interrupt generation after the eighth falling edge of a received matching address. Once a matching address has been clocked in, CKP is cleared and the SSPxIF interrupt is set.

Figure 31-19 displays a standard waveform of a 7-bit address slave transmission with AHEN enabled.

1. Bus starts Idle.
2. Master sends Start condition; the S bit of SSPxSTAT is set; SSPxIF is set if interrupt on Start detect is enabled.
3. Master sends matching address with $\overline{R/W}$ bit set. After the eighth falling edge of the SCL line the CKP bit is cleared and SSPxIF interrupt is generated.
4. Slave software clears SSPxIF.
5. Slave software reads ACKTIM bit of SSPxCON3 register, and $\overline{R/W}$ and $\overline{D/A}$ of the SSPxSTAT register to determine the source of the interrupt.
6. Slave reads the address value from the SSPxBUF register clearing the BF bit.
7. Slave software decides from this information if it wishes to ACK or not ACK and sets the ACKDT bit of the SSPxCON2 register accordingly.
8. Slave sets the CKP bit releasing SCL.
9. Master clocks in the \overline{ACK} value from the slave.
10. Slave hardware automatically clears the CKP bit and sets SSPxIF after the \overline{ACK} if the $\overline{R/W}$ bit is set.
11. Slave software clears SSPxIF.
12. Slave loads value to transmit to the master into SSPxBUF setting the BF bit.

Note: SSPxBUF cannot be loaded until after the \overline{ACK} .

13. Slave sets the CKP bit releasing the clock.
14. Master clocks out the data from the slave and sends an \overline{ACK} value on the ninth SCL pulse.
15. Slave hardware copies the \overline{ACK} value into the ACKSTAT bit of the SSPxCON2 register.
16. Steps 10-15 are repeated for each byte transmitted to the master from the slave.
17. If the master sends a not \overline{ACK} the slave releases the bus allowing the master to send a Stop and end the communication.

Note: Master must send a not \overline{ACK} on the last byte to ensure that the slave releases the SCL line to receive a Stop.

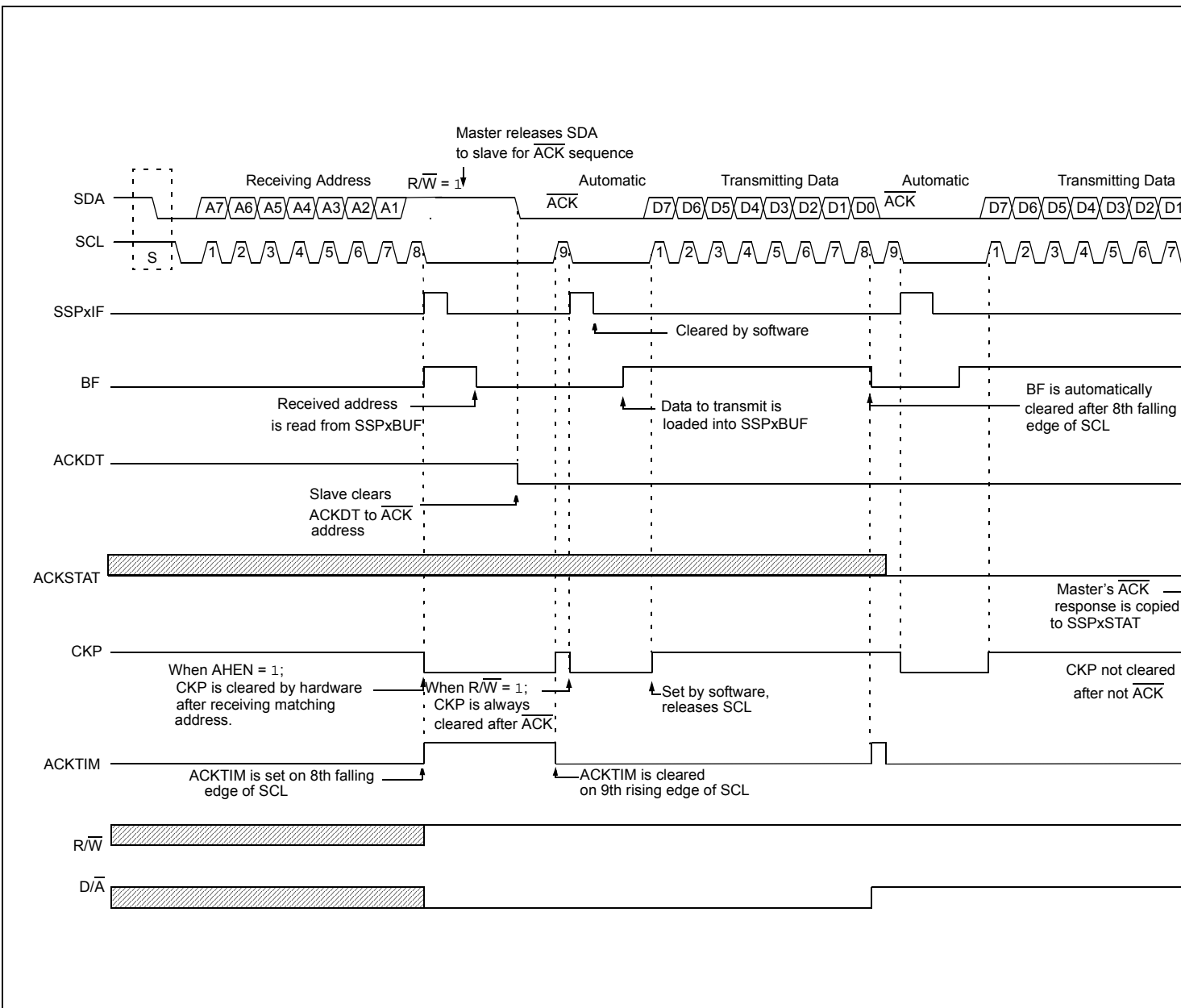

PIC16(L)F18856/76

31.5.4 SLAVE MODE 10-BIT ADDRESS RECEPTION

This section describes a standard sequence of events for the MSSP module configured as an I²C slave in 10-bit Addressing mode.

Figure 31-20 is used as a visual reference for this description.

This is a step by step process of what must be done by slave software to accomplish I²C communication.

1. Bus starts Idle.
2. Master sends Start condition; S bit of SSPxSTAT is set; SSPxIF is set if interrupt on Start detect is enabled.
3. Master sends matching high address with $\overline{R/W}$ bit clear; UA bit of the SSPxSTAT register is set.
4. Slave sends \overline{ACK} and SSPxIF is set.
5. Software clears the SSPxIF bit.
6. Software reads received address from SSPxBUF clearing the BF flag.
7. Slave loads low address into SSPxADD, releasing SCL.
8. Master sends matching low address byte to the slave; UA bit is set.

Note: Updates to the SSPxADD register are not allowed until after the ACK sequence.

9. Slave sends \overline{ACK} and SSPxIF is set.

Note: If the low address does not match, SSPxIF and UA are still set so that the slave software can set SSPxADD back to the high address. BF is not set because there is no match. CKP is unaffected.

10. Slave clears SSPxIF.
11. Slave reads the received matching address from SSPxBUF clearing BF.
12. Slave loads high address into SSPxADD.
13. Master clocks a data byte to the slave and clocks out the slaves ACK on the ninth SCL pulse; SSPxIF is set.
14. If SEN bit of SSPxCON2 is set, CKP is cleared by hardware and the clock is stretched.
15. Slave clears SSPxIF.
16. Slave reads the received byte from SSPxBUF clearing BF.
17. If SEN is set the slave sets CKP to release the SCL.
18. Steps 13-17 repeat for each received byte.
19. Master sends Stop to end the transmission.

31.5.5 10-BIT ADDRESSING WITH ADDRESS OR DATA HOLD

Reception using 10-bit addressing with AHEN or DHEN set is the same as with 7-bit modes. The only difference is the need to update the SSPxADD register using the UA bit. All functionality, specifically when the CKP bit is cleared and SCL line is held low are the same. Figure 31-21 can be used as a reference of a slave in 10-bit addressing with AHEN set.

Figure 31-22 shows a standard waveform for a slave transmitter in 10-bit Addressing mode.

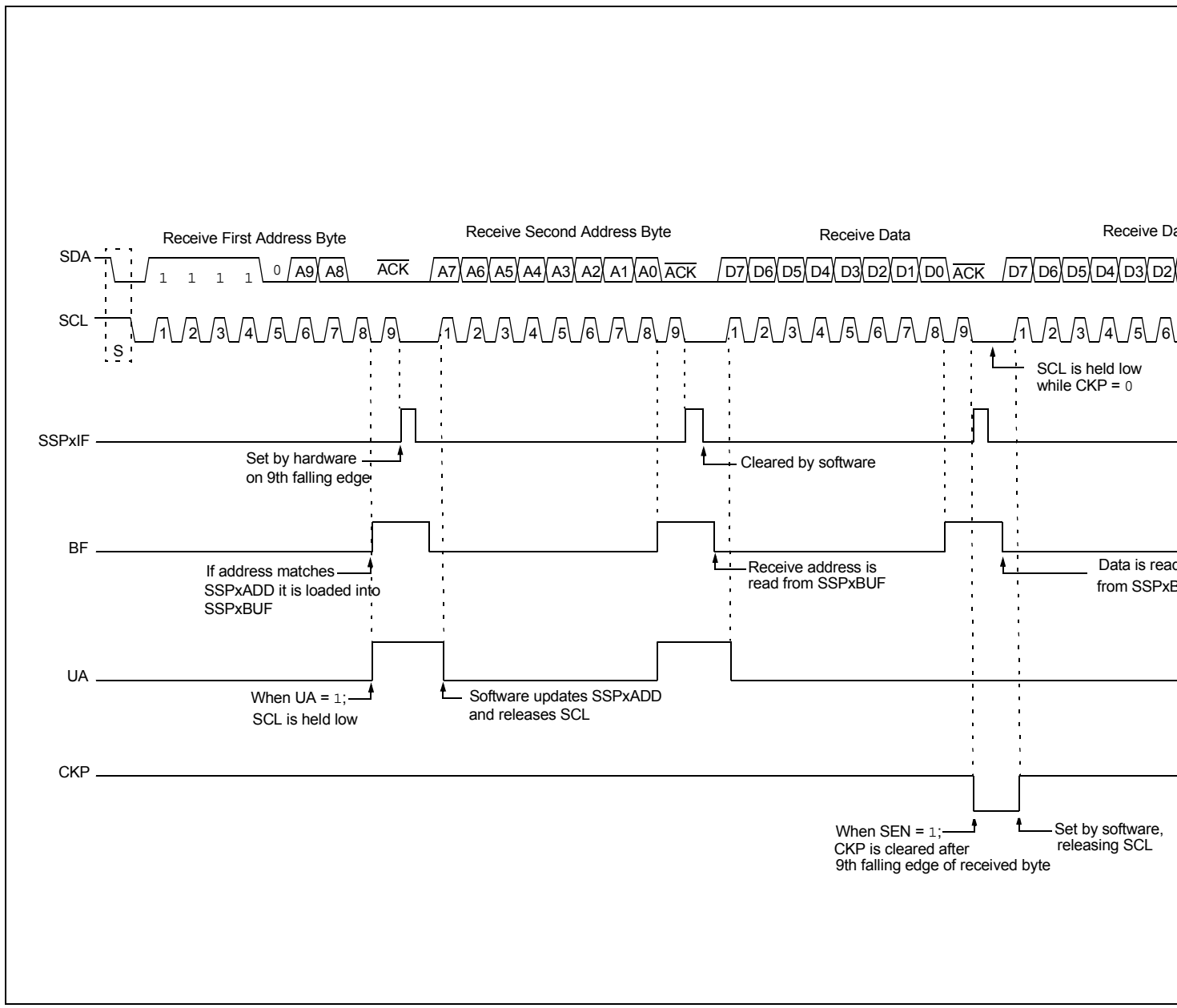

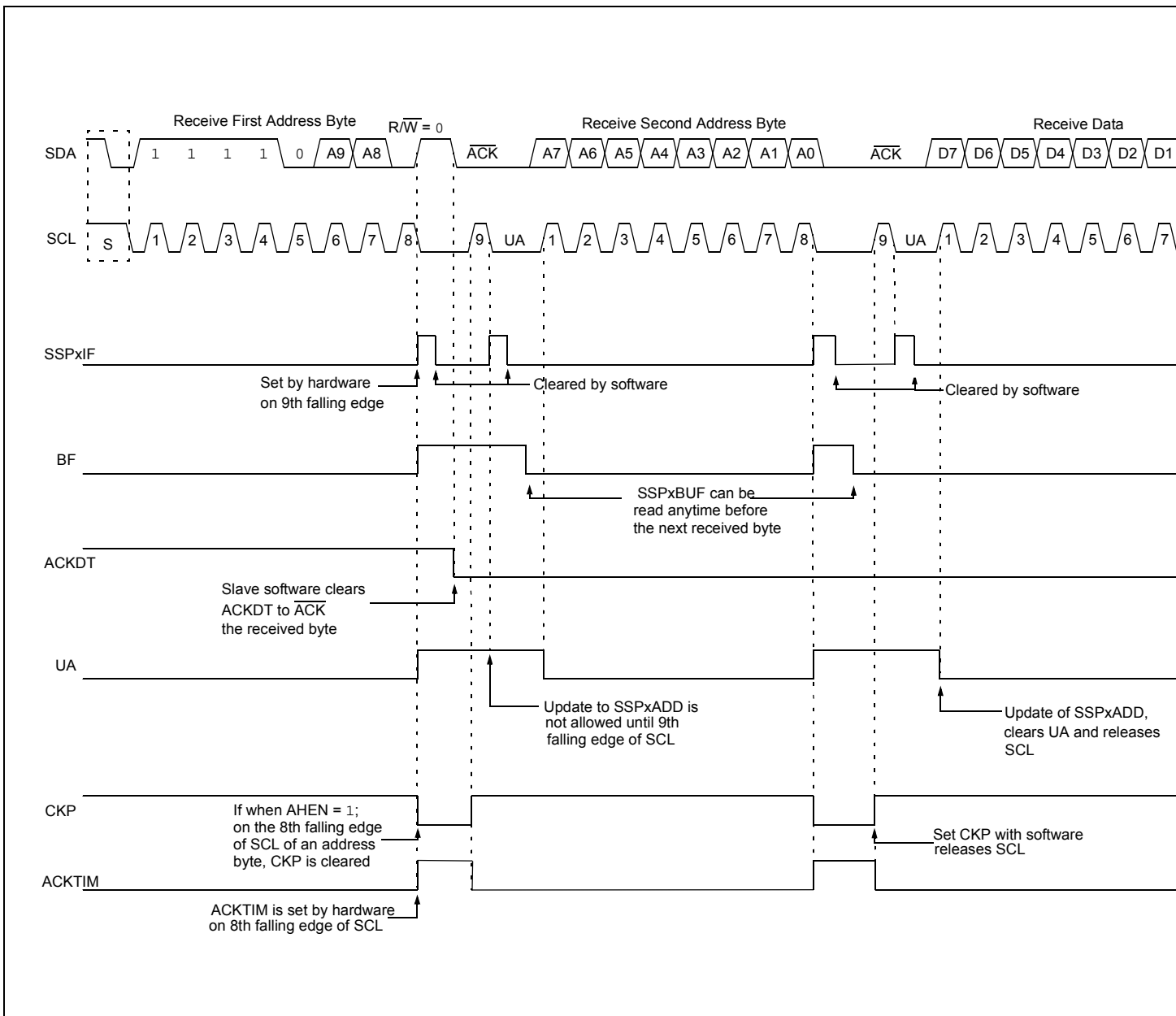

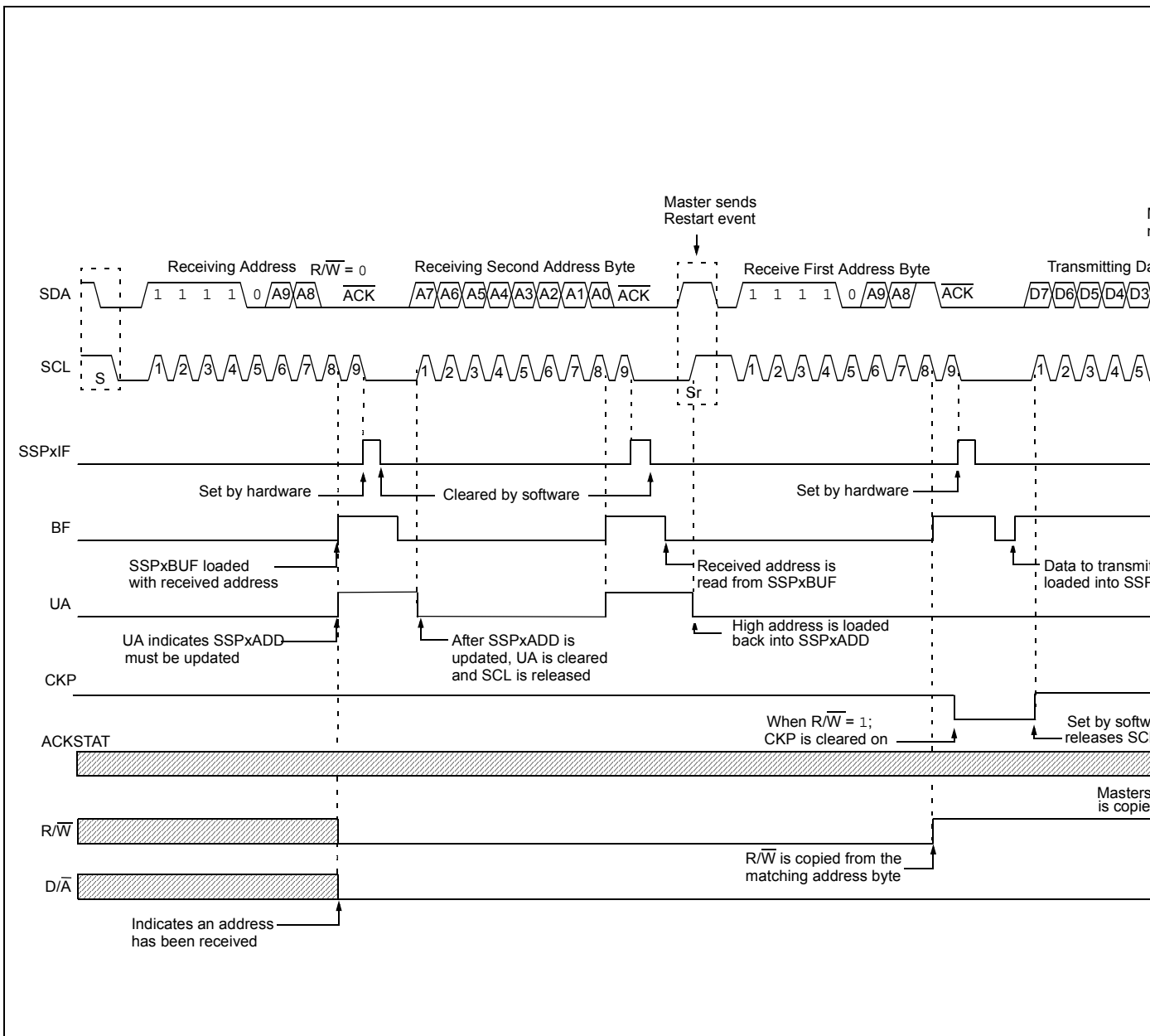

PIC16(L)F18856/76

31.5.6 CLOCK STRETCHING

Clock stretching occurs when a device on the bus holds the SCL line low, effectively pausing communication. The slave may stretch the clock to allow more time to handle data or prepare a response for the master device. A master device is not concerned with stretching as anytime it is active on the bus and not transferring data it is stretching. Any stretching done by a slave is invisible to the master software and handled by the hardware that generates SCL.

The CKP bit of the SSPxCON1 register is used to control stretching in software. Any time the CKP bit is cleared, the module will wait for the SCL line to go low and then hold it. Setting CKP will release SCL and allow more communication.

31.5.6.1 Normal Clock Stretching

Following an $\overline{\text{ACK}}$ if the $\overline{\text{R/W}}$ bit of SSPxSTAT is set, a read request, the slave hardware will clear CKP. This allows the slave time to update SSPxBUF with data to transfer to the master. If the SEN bit of SSPxCON2 is set, the slave hardware will always stretch the clock after the $\overline{\text{ACK}}$ sequence. Once the slave is ready; CKP is set by software and communication resumes.

Note 1: The BF bit has no effect on if the clock will be stretched or not. This is different than previous versions of the module that would not stretch the clock, clear CKP, if SSPxBUF was read before the ninth falling edge of SCL.

2: Previous versions of the module did not stretch the clock for a transmission if SSPxBUF was loaded before the ninth falling edge of SCL. It is now always cleared for read requests.

31.5.6.2 10-bit Addressing Mode

In 10-bit Addressing mode, when the UA bit is set the clock is always stretched. This is the only time the SCL is stretched without CKP being cleared. SCL is released immediately after a write to SSPxADD.

Note: Previous versions of the module did not stretch the clock if the second address byte did not match.

31.5.6.3 Byte NACKing

When AHEN bit of SSPxCON3 is set; CKP is cleared by hardware after the eighth falling edge of SCL for a received matching address byte. When DHEN bit of SSPxCON3 is set; CKP is cleared after the eighth falling edge of SCL for received data.

Stretching after the eighth falling edge of SCL allows the slave to look at the received address or data and decide if it wants to ACK the received data.

31.5.7 CLOCK SYNCHRONIZATION AND THE CKP BIT

Any time the CKP bit is cleared, the module will wait for the SCL line to go low and then hold it. However, clearing the CKP bit will not assert the SCL output low until the SCL output is already sampled low. Therefore, the CKP bit will not assert the SCL line until an external I²C master device has already asserted the SCL line. The SCL output will remain low until the CKP bit is set and all other devices on the I²C bus have released SCL. This ensures that a write to the CKP bit will not violate the minimum high time requirement for SCL (see Figure 31-23).

FIGURE 31-23: CLOCK SYNCHRONIZATION TIMING

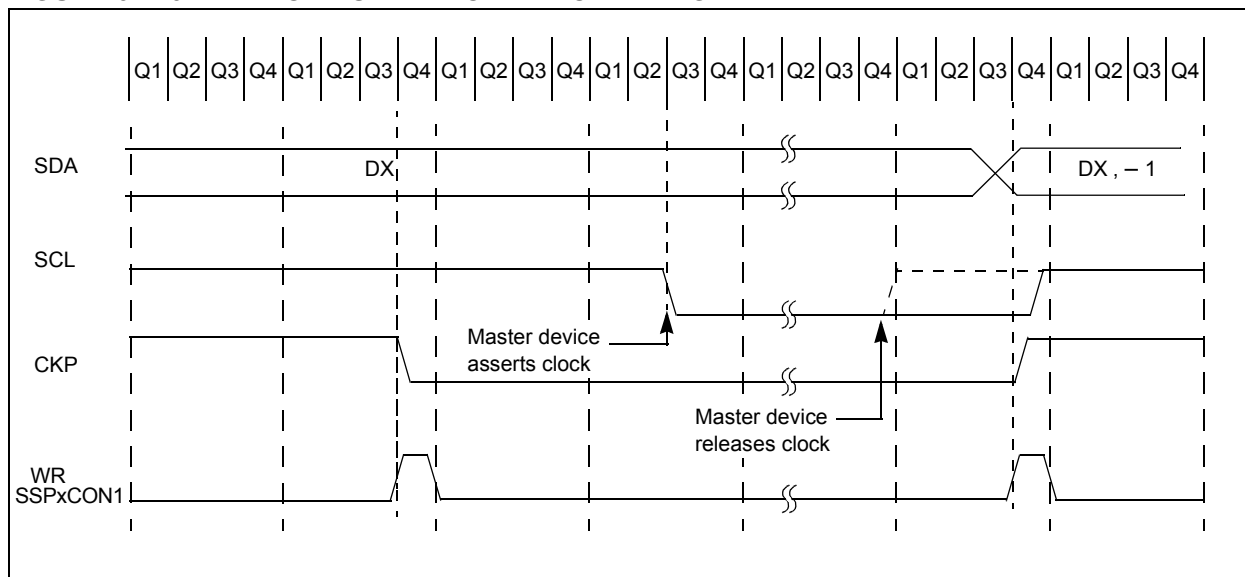

PIC16(L)F18856/76

31.5.8 GENERAL CALL ADDRESS SUPPORT

The addressing procedure for the I²C bus is such that the first byte after the Start condition usually determines which device will be the slave addressed by the master device. The exception is the general call address which can address all devices. When this address is used, all devices should, in theory, respond with an acknowledge.

The general call address is a reserved address in the I²C protocol, defined as address 0x00. When the GCEN bit of the SSPxCON2 register is set, the slave module will automatically ACK the reception of this address regardless of the value stored in SSPxADD. After the slave clocks in an address of all zeros with the R/W bit clear, an interrupt is generated and slave software can read SSPxBUF and respond. Figure 31-24 shows a general call reception sequence.

In 10-bit Address mode, the UA bit will not be set on the reception of the general call address. The slave will prepare to receive the second byte as data, just as it would in 7-bit mode.

If the AHEN bit of the SSPxCON3 register is set, just as with any other address reception, the slave hardware will stretch the clock after the eighth falling edge of SCL. The slave must then set its ACKDT value and release the clock with communication progressing as it would normally.

FIGURE 31-24: SLAVE MODE GENERAL CALL ADDRESS SEQUENCE

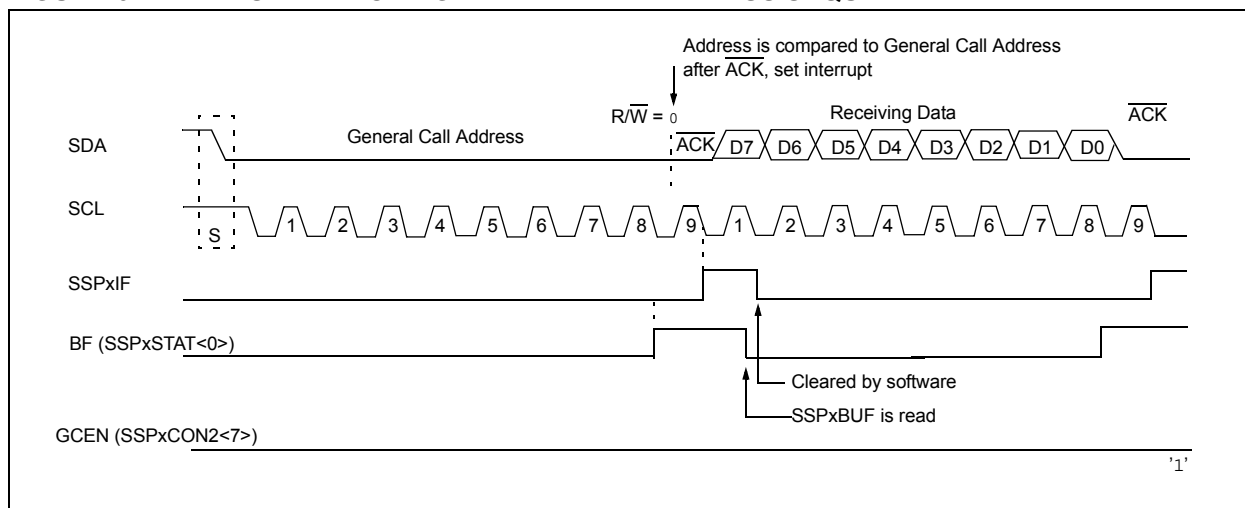

31.5.9 SSP MASK REGISTER

An SSP Mask (SSPxMSK) register (Register 31-5) is available in I²C Slave mode as a mask for the value held in the SSPxSR register during an address comparison operation. A zero ('0') bit in the SSPxMSK register has the effect of making the corresponding bit of the received address a "don't care".

This register is reset to all '1's upon any Reset condition and, therefore, has no effect on standard SSP operation until written with a mask value.

The SSP Mask register is active during:

- 7-bit Address mode: address compare of A<7:1>.
- 10-bit Address mode: address compare of A<7:0> only. The SSP mask has no effect during the reception of the first (high) byte of the address.

31.6 I²C Master Mode

Master mode is enabled by setting and clearing the appropriate SSPM bits in the SSPxCON1 register and by setting the SSPEN bit. In Master mode, the SDA and SCK pins must be configured as inputs. The MSSP peripheral hardware will override the output driver TRIS controls when necessary to drive the pins low.

Master mode of operation is supported by interrupt generation on the detection of the Start and Stop conditions. The Stop (P) and Start (S) bits are cleared from a Reset or when the MSSP module is disabled. Control of the I²C bus may be taken when the P bit is set, or the bus is Idle.

In Firmware Controlled Master mode, user code conducts all I²C bus operations based on Start and Stop bit condition detection. Start and Stop condition detection is the only active circuitry in this mode. All other communication is done by the user software directly manipulating the SDA and SCL lines.

The following events will cause the SSP Interrupt Flag bit, SSPxIF, to be set (SSP interrupt, if enabled):

- Start condition detected
- Stop condition detected
- Data transfer byte transmitted/received
- Acknowledge transmitted/received
- Repeated Start generated

Note 1: The MSSP module, when configured in I²C Master mode, does not allow queuing of events. For instance, the user is not allowed to initiate a Start condition and immediately write the SSPxBUF register to initiate transmission before the Start condition is complete. In this case, the SSPxBUF will not be written to and the WCOL bit will be set, indicating that a write to the SSPxBUF did not occur

2: Master mode suspends Start/Stop detection when sending the Start/Stop condition by means of the SEN/PEN control bits. The SSPxIF bit is set at the end of the Start/Stop generation when hardware clears the control bit.

31.6.1 I²C MASTER MODE OPERATION

The master device generates all of the serial clock pulses and the Start and Stop conditions. A transfer is ended with a Stop condition or with a Repeated Start condition. Since the Repeated Start condition is also the beginning of the next serial transfer, the I²C bus will not be released.

In Master Transmitter mode, serial data is output through SDA, while SCL outputs the serial clock. The first byte transmitted contains the slave address of the receiving device (7 bits) and the Read/Write (R/W) bit. In this case, the R/W bit will be logic '0'. Serial data is transmitted eight bits at a time. After each byte is transmitted, an Acknowledge bit is received. Start and Stop conditions are output to indicate the beginning and the end of a serial transfer.

In Master Receive mode, the first byte transmitted contains the slave address of the transmitting device (7 bits) and the R/W bit. In this case, the R/W bit will be logic '1'. Thus, the first byte transmitted is a 7-bit slave address followed by a '1' to indicate the receive bit. Serial data is received via SDA, while SCL outputs the serial clock. Serial data is received eight bits at a time. After each byte is received, an Acknowledge bit is transmitted. Start and Stop conditions indicate the beginning and end of transmission.

A Baud Rate Generator is used to set the clock frequency output on SCL. See [Section 31.7 "Baud Rate Generator"](#) for more detail.

PIC16(L)F18856/76

31.6.2 CLOCK ARBITRATION

Clock arbitration occurs when the master, during any receive, transmit or Repeated Start/Stop condition, releases the SCL pin (SCL allowed to float high). When the SCL pin is allowed to float high, the Baud Rate Generator (BRG) is suspended from counting until the SCL pin is actually sampled high. When the SCL pin is sampled high, the Baud Rate Generator is reloaded with the contents of SSPxADD<7:0> and begins counting. This ensures that the SCL high time will always be at least one BRG rollover count in the event that the clock is held low by an external device (Figure 31-25).

FIGURE 31-25: BAUD RATE GENERATOR TIMING WITH CLOCK ARBITRATION

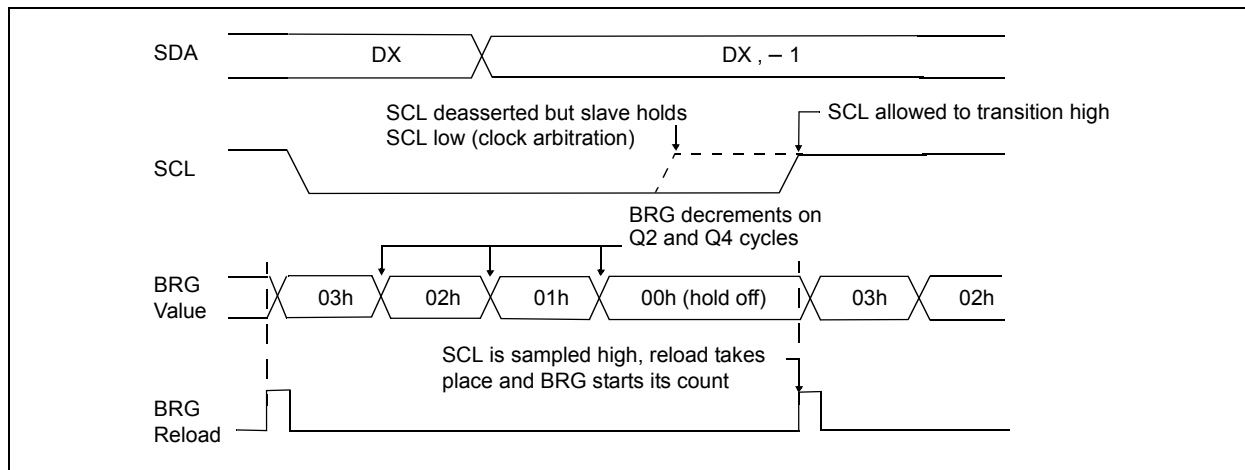

31.6.3 WCOL STATUS FLAG

If the user writes the SSPxBUF when a Start, Restart, Stop, Receive or Transmit sequence is in progress, the WCOL is set and the contents of the buffer are unchanged (the write does not occur). Any time the WCOL bit is set it indicates that an action on SSPxBUF was attempted while the module was not idle.

Note: Because queuing of events is not allowed, writing to the lower five bits of SSPxCON2 is disabled until the Start condition is complete.

PIC16(L)F18856/76

31.6.4 I²C MASTER MODE START CONDITION TIMING

To initiate a Start condition (Figure 31-26), the user sets the Start Enable bit, SEN bit of the SSPxCON2 register. If the SDA and SCL pins are sampled high, the Baud Rate Generator is reloaded with the contents of SSPxADD<7:0> and starts its count. If SCL and SDA are both sampled high when the Baud Rate Generator times out (TBRG), the SDA pin is driven low. The action of the SDA being driven low while SCL is high is the Start condition and causes the S bit of the SSPxSTAT1 register to be set. Following this, the Baud Rate Generator is reloaded with the contents of SSPxADD<7:0> and resumes its count. When the Baud Rate Generator times out (TBRG), the SEN bit of the SSPxCON2 register will be automatically cleared by hardware; the Baud Rate Generator is suspended, leaving the SDA line held low and the Start condition is complete.

Note 1: If at the beginning of the Start condition, the SDA and SCL pins are already sampled low, or if during the Start condition, the SCL line is sampled low before the SDA line is driven low, a bus collision occurs, the Bus Collision Interrupt Flag, BCLIF, is set, the Start condition is aborted and the I²C module is reset into its Idle state.

2: The Philips I²C specification states that a bus collision cannot occur on a Start.

FIGURE 31-26: FIRST START BIT TIMING

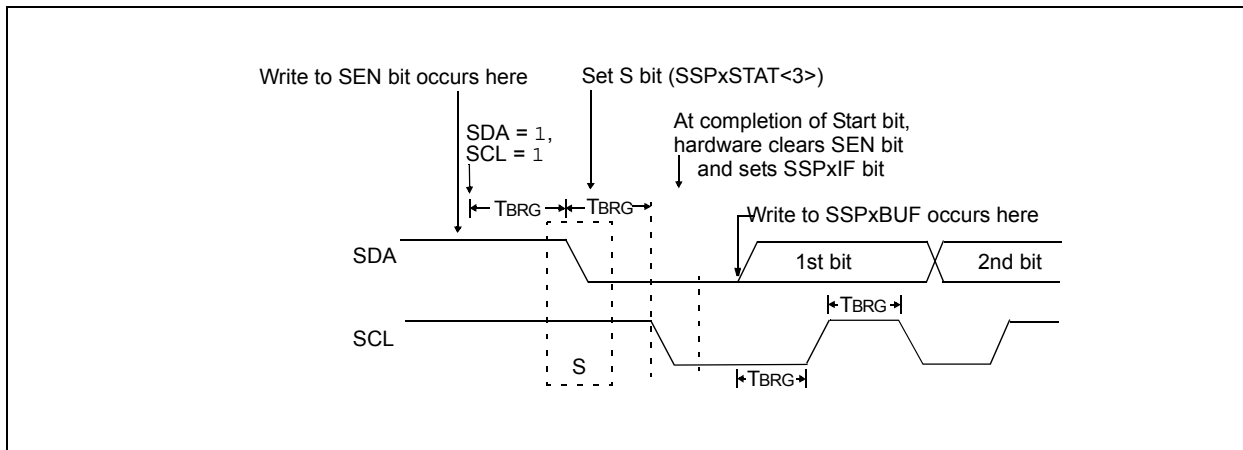

PIC16(L)F18856/76

31.6.5 I²C MASTER MODE REPEATED START CONDITION TIMING

A Repeated Start condition (Figure 31-27) occurs when the RSEN bit of the SSPxCON2 register is programmed high and the master state machine is no longer active. When the RSEN bit is set, the SCL pin is asserted low. When the SCL pin is sampled low, the Baud Rate Generator is loaded and begins counting. The SDA pin is released (brought high) for one Baud Rate Generator count (TBRG). When the Baud Rate Generator times out, if SDA is sampled high, the SCL pin will be deasserted (brought high). When SCL is sampled high, the Baud Rate Generator is reloaded and begins counting. SDA and SCL must be sampled high for one TBRG. This action is then followed by assertion of the SDA pin (SDA = 0) for one TBRG while SCL is high. SCL is asserted low. Following this, the RSEN bit of the SSPxCON2 register will be automati-

cally cleared and the Baud Rate Generator will not be reloaded, leaving the SDA pin held low. As soon as a Start condition is detected on the SDA and SCL pins, the S bit of the SSPxSTAT register will be set. The SSPxIF bit will not be set until the Baud Rate Generator has timed out.

Note 1: If RSEN is programmed while any other event is in progress, it will not take effect.

2: A bus collision during the Repeated Start condition occurs if:

- SDA is sampled low when SCL goes from low-to-high.
- SCL goes low before SDA is asserted low. This may indicate that another master is attempting to transmit a data '1'.

FIGURE 31-27: REPEATED START CONDITION WAVEFORM

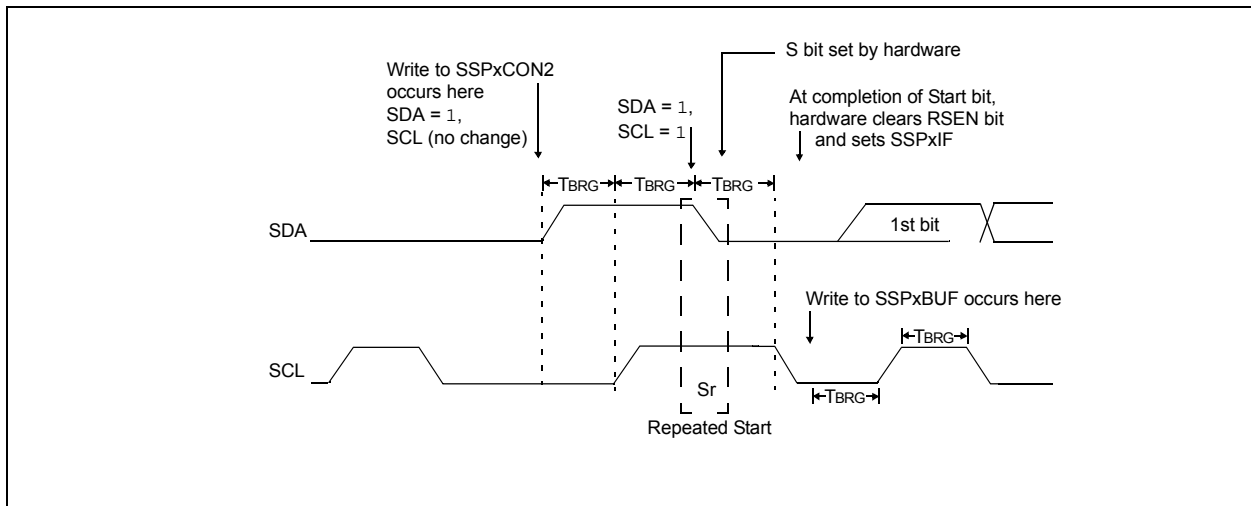

PIC16(L)F18856/76

31.6.6 I²C MASTER MODE TRANSMISSION

Transmission of a data byte, a 7-bit address or the other half of a 10-bit address is accomplished by simply writing a value to the SSPxBUF register. This action will set the Buffer Full flag bit, BF, and allow the Baud Rate Generator to begin counting and start the next transmission. Each bit of address/data will be shifted out onto the SDA pin after the falling edge of SCL is asserted. SCL is held low for one Baud Rate Generator rollover count (TBRG). Data should be valid before SCL is released high. When the SCL pin is released high, it is held that way for TBRG. The data on the SDA pin must remain stable for that duration and some hold time after the next falling edge of SCL. After the eighth bit is shifted out (the falling edge of the eighth clock), the BF flag is cleared and the master releases SDA. This allows the slave device being addressed to respond with an ACK bit during the ninth bit time if an address match occurred, or if data was received properly. The status of $\overline{\text{ACK}}$ is written into the ACKSTAT bit on the rising edge of the ninth clock. If the master receives an Acknowledge, the Acknowledge Status bit, ACKSTAT, is cleared. If not, the bit is set. After the ninth clock, the SSPxIF bit is set and the master clock (Baud Rate Generator) is suspended until the next data byte is loaded into the SSPxBUF, leaving SCL low and SDA unchanged (Figure 31-28).

After the write to the SSPxBUF, each bit of the address will be shifted out on the falling edge of SCL until all seven address bits and the R/W bit are completed. On the falling edge of the eighth clock, the master will release the SDA pin, allowing the slave to respond with an Acknowledge. On the falling edge of the ninth clock, the master will sample the SDA pin to see if the address was recognized by a slave. The status of the ACK bit is loaded into the ACKSTAT Status bit of the SSPxCON2 register. Following the falling edge of the ninth clock transmission of the address, the SSPxIF is set, the BF flag is cleared and the Baud Rate Generator is turned off until another write to the SSPxBUF takes place, holding SCL low and allowing SDA to float.

31.6.6.1 BF Status Flag

In Transmit mode, the BF bit of the SSPxSTAT register is set when the CPU writes to SSPxBUF and is cleared when all eight bits are shifted out.

31.6.6.2 WCOL Status Flag

If the user writes the SSPxBUF when a transmit is already in progress (i.e., SSPxSR is still shifting out a data byte), the WCOL bit is set and the contents of the buffer are unchanged (the write does not occur).

WCOL must be cleared by software before the next transmission.

31.6.6.3 ACKSTAT Status Flag

In Transmit mode, the ACKSTAT bit of the SSPxCON2 register is cleared when the slave has sent an Acknowledge ($\text{ACK} = 0$) and is set when the slave does not Acknowledge ($\text{ACK} = 1$). A slave sends an Acknowledge when it has recognized its address (including a general call), or when the slave has properly received its data.

31.6.6.4 Typical transmit sequence:

1. The user generates a Start condition by setting the SEN bit of the SSPxCON2 register.
2. SSPxIF is set by hardware on completion of the Start.
3. SSPxIF is cleared by software.
4. The MSSP module will wait the required start time before any other operation takes place.
5. The user loads the SSPxBUF with the slave address to transmit.
6. Address is shifted out the SDA pin until all eight bits are transmitted. Transmission begins as soon as SSPxBUF is written to.
7. The MSSP module shifts in the $\overline{\text{ACK}}$ bit from the slave device and writes its value into the ACKSTAT bit of the SSPxCON2 register.
8. The MSSP module generates an interrupt at the end of the ninth clock cycle by setting the SSPxIF bit.
9. The user loads the SSPxBUF with eight bits of data.
10. Data is shifted out the SDA pin until all eight bits are transmitted.
11. The MSSP module shifts in the $\overline{\text{ACK}}$ bit from the slave device and writes its value into the ACKSTAT bit of the SSPxCON2 register.
12. Steps 8-11 are repeated for all transmitted data bytes.
13. The user generates a Stop or Restart condition by setting the PEN or RSEN bits of the SSPxCON2 register. Interrupt is generated once the Stop/Restart condition is complete.

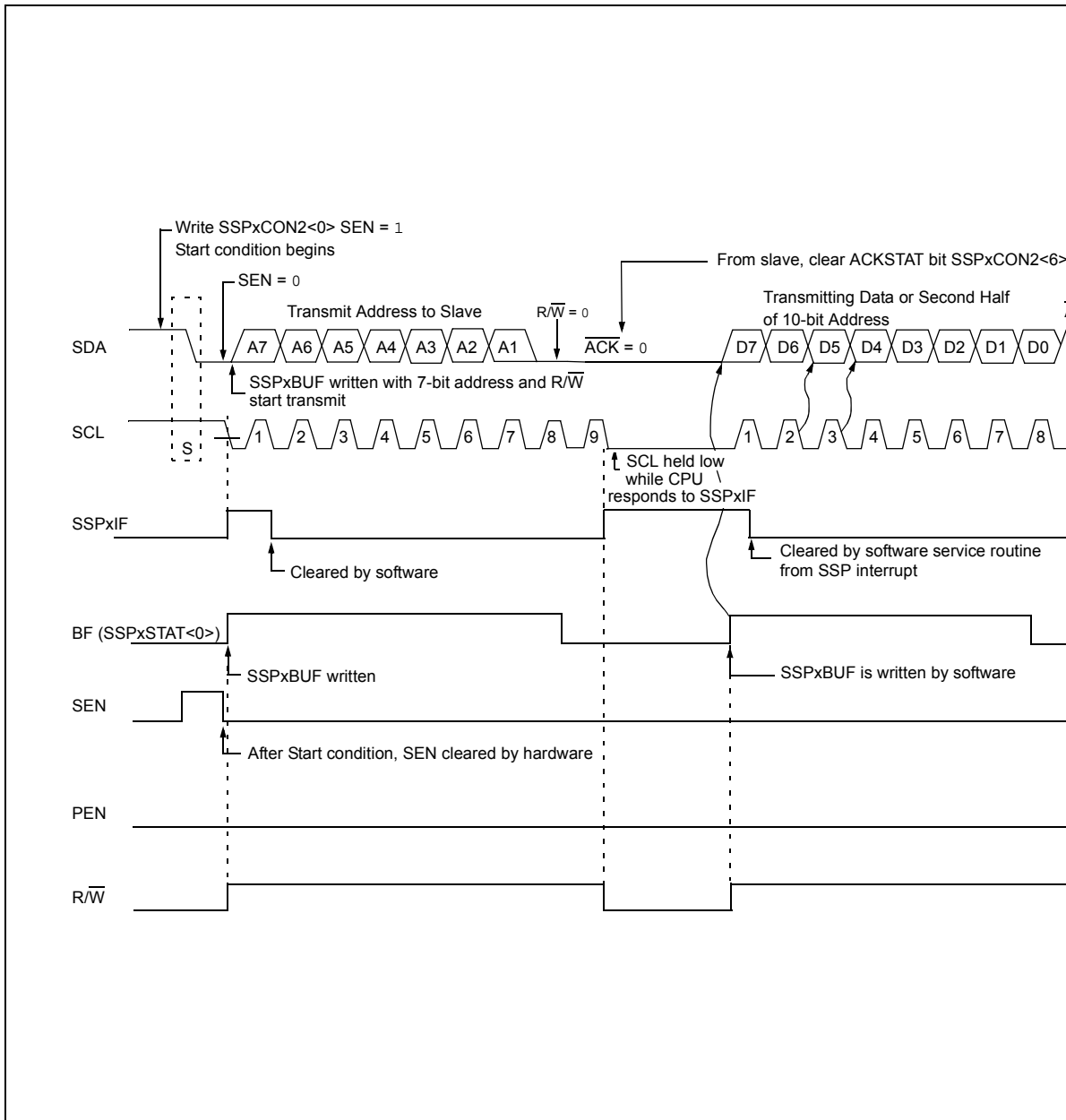

PIC16(L)F18856/76

31.6.7 I²C MASTER MODE RECEPTION

Master mode reception (Figure 31-29) is enabled by programming the Receive Enable bit, RCEN bit of the SSPxCON2 register.

Note: The MSSP module must be in an Idle state before the RCEN bit is set or the RCEN bit will be disregarded.

The Baud Rate Generator begins counting and on each rollover, the state of the SCL pin changes (high-to-low/low-to-high) and data is shifted into the SSPxSR. After the falling edge of the eighth clock, the receive enable flag is automatically cleared, the contents of the SSPxSR are loaded into the SSPxBUF, the BF flag bit is set, the SSPxIF flag bit is set and the Baud Rate Generator is suspended from counting, holding SCL low. The MSSP is now in Idle state awaiting the next command. When the buffer is read by the CPU, the BF flag bit is automatically cleared. The user can then send an Acknowledge bit at the end of reception by setting the Acknowledge Sequence Enable, ACKEN bit of the SSPxCON2 register.

31.6.7.1 BF Status Flag

In receive operation, the BF bit is set when an address or data byte is loaded into SSPxBUF from SSPxSR. It is cleared when the SSPxBUF register is read.

31.6.7.2 SSPOV Status Flag

In receive operation, the SSPOV bit is set when eight bits are received into the SSPxSR and the BF flag bit is already set from a previous reception.

31.6.7.3 WCOL Status Flag

If the user writes the SSPxBUF when a receive is already in progress (i.e., SSPxSR is still shifting in a data byte), the WCOL bit is set and the contents of the buffer are unchanged (the write does not occur).

31.6.7.4 Typical Receive Sequence:

1. The user generates a Start condition by setting the SEN bit of the SSPxCON2 register.
2. SSPxIF is set by hardware on completion of the Start.
3. SSPxIF is cleared by software.
4. User writes SSPxBUF with the slave address to transmit and the R/W bit set.
5. Address is shifted out the SDA pin until all eight bits are transmitted. Transmission begins as soon as SSPxBUF is written to.
6. The MSSP module shifts in the \overline{ACK} bit from the slave device and writes its value into the ACKSTAT bit of the SSPxCON2 register.
7. The MSSP module generates an interrupt at the end of the ninth clock cycle by setting the SSPxIF bit.
8. User sets the RCEN bit of the SSPxCON2 register and the master clocks in a byte from the slave.
9. After the eighth falling edge of SCL, SSPxIF and BF are set.
10. Master clears SSPxIF and reads the received byte from SSPxBUF, clears BF.
11. Master sets \overline{ACK} value sent to slave in ACKDT bit of the SSPxCON2 register and initiates the ACK by setting the ACKEN bit.
12. Master's ACK is clocked out to the slave and SSPxIF is set.
13. User clears SSPxIF.
14. Steps 8-13 are repeated for each received byte from the slave.
15. Master sends a not \overline{ACK} or Stop to end communication.

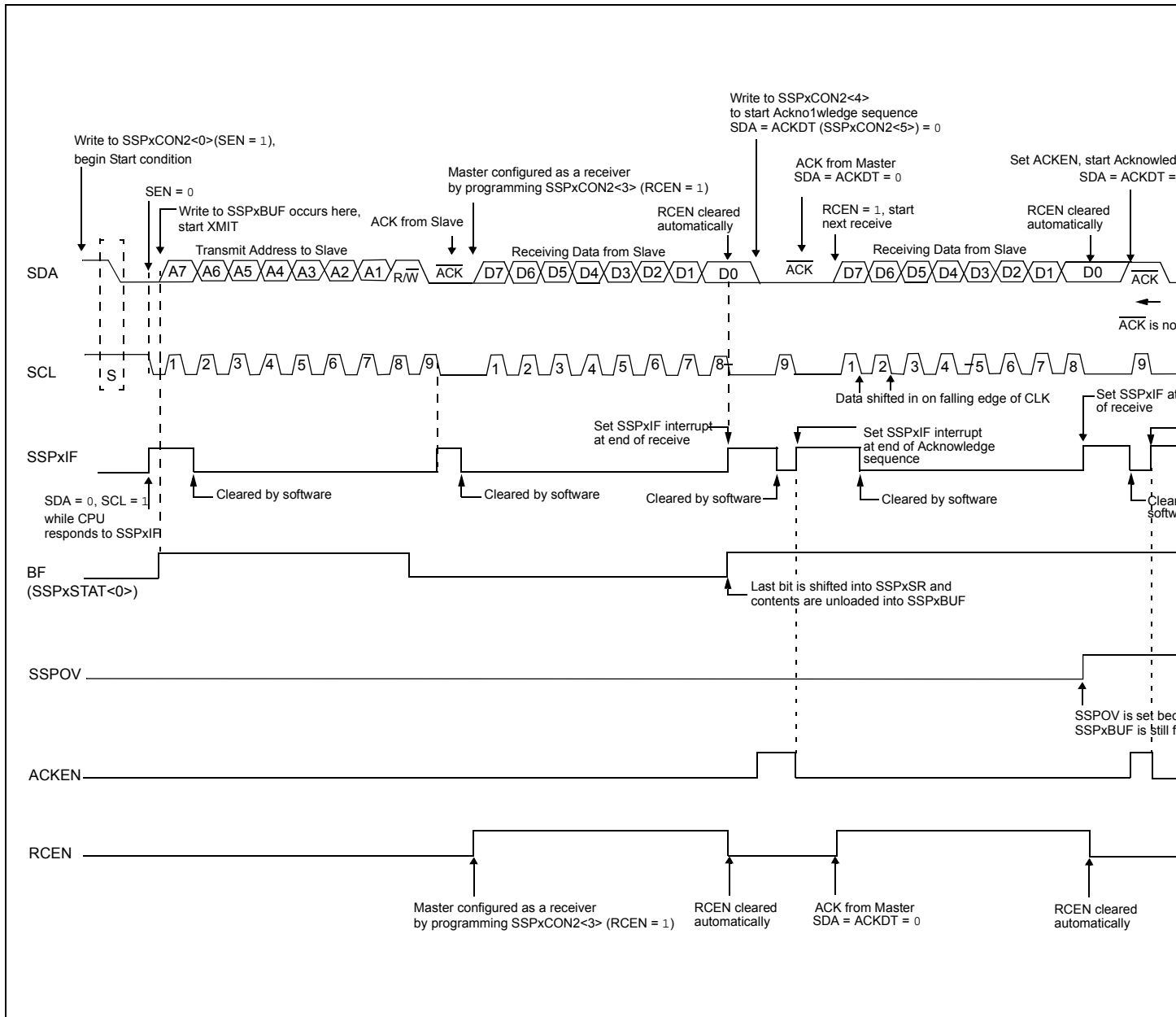

PIC16(L)F18856/76

31.6.8 ACKNOWLEDGE SEQUENCE TIMING

An Acknowledge sequence is enabled by setting the Acknowledge Sequence Enable bit, ACKEN bit of the SSPxCON2 register. When this bit is set, the SCL pin is pulled low and the contents of the Acknowledge data bit are presented on the SDA pin. If the user wishes to generate an Acknowledge, then the ACKDT bit should be cleared. If not, the user should set the ACKDT bit before starting an Acknowledge sequence. The Baud Rate Generator then counts for one rollover period (TBRG) and the SCL pin is deasserted (pulled high). When the SCL pin is sampled high (clock arbitration), the Baud Rate Generator counts for TBRG. The SCL pin is then pulled low. Following this, the ACKEN bit is automatically cleared, the Baud Rate Generator is turned off and the MSSP module then goes into IDLE mode (Figure 31-30).

31.6.8.1 WCOL Status Flag

If the user writes the SSPxBUF when an Acknowledge sequence is in progress, then WCOL bit is set and the contents of the buffer are unchanged (the write does not occur).

31.6.9 STOP CONDITION TIMING

A Stop bit is asserted on the SDA pin at the end of a receive/transmit by setting the Stop Sequence Enable bit, PEN bit of the SSPxCON2 register. At the end of a receive/transmit, the SCL line is held low after the falling edge of the ninth clock. When the PEN bit is set, the master will assert the SDA line low. When the SDA line is sampled low, the Baud Rate Generator is reloaded and counts down to '0'. When the Baud Rate Generator times out, the SCL pin will be brought high and one TBRG (Baud Rate Generator rollover count) later, the SDA pin will be deasserted. When the SDA pin is sampled high while SCL is high, the P bit of the SSPxSTAT register is set. A TBRG later, the PEN bit is cleared and the SSPxIF bit is set (Figure 31-31).

31.6.9.1 WCOL Status Flag

If the user writes the SSPxBUF when a Stop sequence is in progress, then the WCOL bit is set and the contents of the buffer are unchanged (the write does not occur).

FIGURE 31-30: ACKNOWLEDGE SEQUENCE WAVEFORM

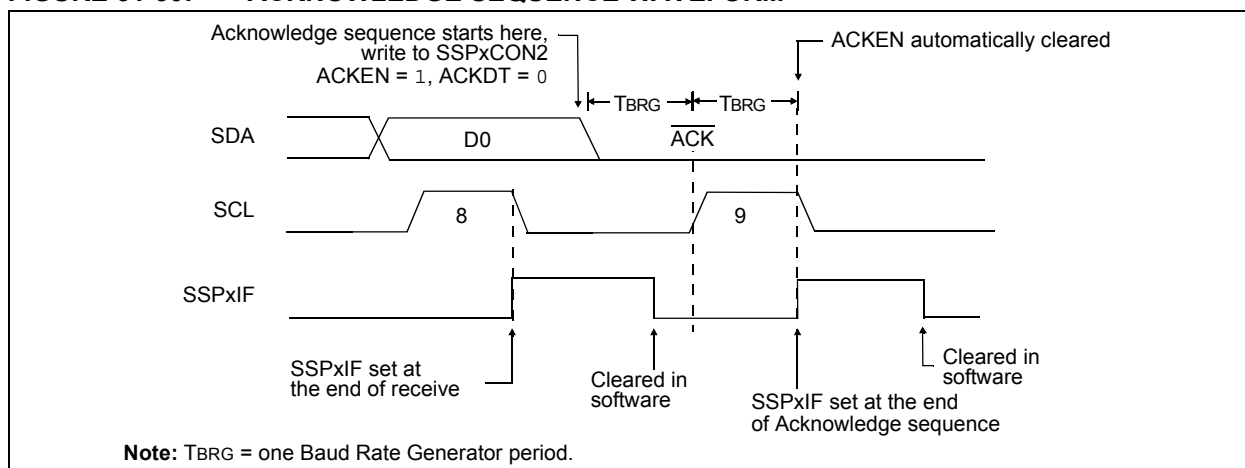
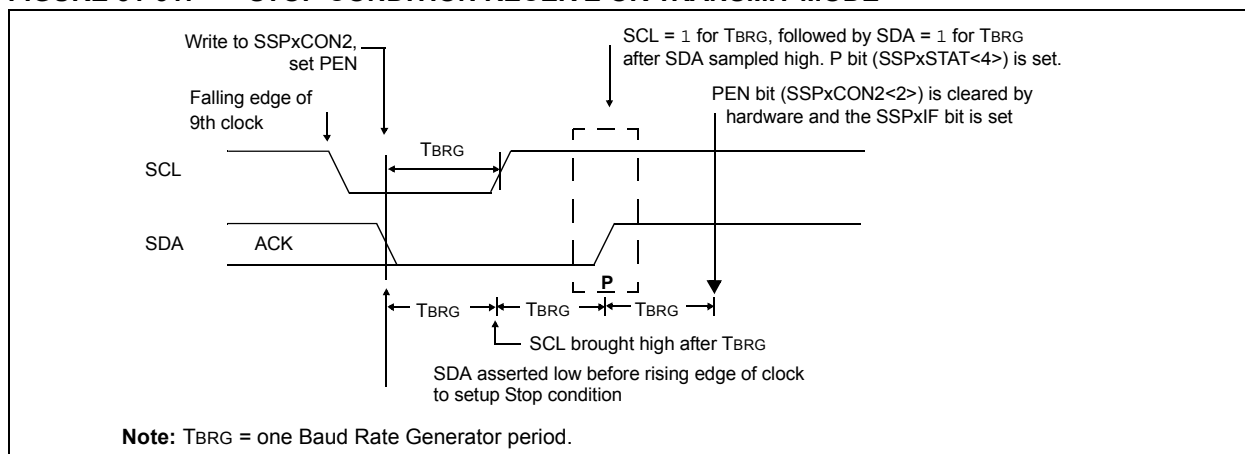

FIGURE 31-31: STOP CONDITION RECEIVE OR TRANSMIT MODE



PIC16(L)F18856/76

31.6.10 SLEEP OPERATION

While in Sleep mode, the I²C slave module can receive addresses or data and when an address match or complete byte transfer occurs, wake the processor from Sleep (if the MSSP interrupt is enabled).

31.6.11 EFFECTS OF A RESET

A Reset disables the MSSP module and terminates the current transfer.

31.6.12 MULTI-MASTER MODE

In Multi-Master mode, the interrupt generation on the detection of the Start and Stop conditions allows the determination of when the bus is free. The Stop (P) and Start (S) bits are cleared from a Reset or when the MSSP module is disabled. Control of the I²C bus may be taken when the P bit of the SSPxSTAT register is set, or the bus is Idle, with both the S and P bits clear. When the bus is busy, enabling the SSP interrupt will generate the interrupt when the Stop condition occurs.

In multi-master operation, the SDA line must be monitored for arbitration to see if the signal level is the expected output level. This check is performed by hardware with the result placed in the BCL1IF bit.

The states where arbitration can be lost are:

- Address Transfer
- Data Transfer
- A Start Condition
- A Repeated Start Condition
- An Acknowledge Condition

31.6.13 MULTI-MASTER COMMUNICATION, BUS COLLISION AND BUS ARBITRATION

Multi-Master mode support is achieved by bus arbitration. When the master outputs address/data bits onto the SDA pin, arbitration takes place when the master outputs a '1' on SDA, by letting SDA float high and another master asserts a '0'. When the SCL pin floats high, data should be stable. If the expected data on SDA is a '1' and the data sampled on the SDA pin is '0', then a bus collision has taken place. The master will set the Bus Collision Interrupt Flag, BCL1IF and reset the I²C port to its Idle state (Figure 31-32).

If a transmit was in progress when the bus collision occurred, the transmission is halted, the BF flag is cleared, the SDA and SCL lines are deasserted and the SSPxBUF can be written to. When the user services the bus collision Interrupt Service Routine and if the I²C bus is free, the user can resume communication by asserting a Start condition.

If a Start, Repeated Start, Stop or Acknowledge condition was in progress when the bus collision occurred, the condition is aborted, the SDA and SCL lines are deasserted and the respective control bits in the SSPxCON2 register are cleared. When the user services the bus collision Interrupt Service Routine and if the I²C bus is free, the user can resume communication by asserting a Start condition.

The master will continue to monitor the SDA and SCL pins. If a Stop condition occurs, the SSPxIF bit will be set.

A write to the SSPxBUF will start the transmission of data at the first data bit, regardless of where the transmitter left off when the bus collision occurred.

In Multi-Master mode, the interrupt generation on the detection of Start and Stop conditions allows the determination of when the bus is free. Control of the I²C bus can be taken when the P bit is set in the SSPxSTAT register, or the bus is Idle and the S and P bits are cleared.

FIGURE 31-32: BUS COLLISION TIMING FOR TRANSMIT AND ACKNOWLEDGE

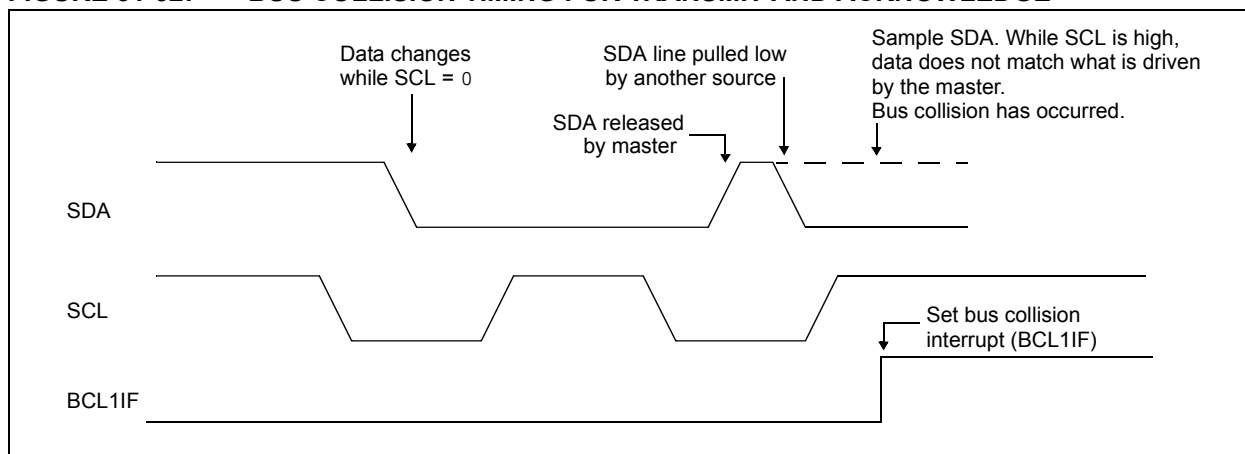

PIC16(L)F18856/76

31.6.13.1 Bus Collision During a Start Condition

During a Start condition, a bus collision occurs if:

- SDA or SCL are sampled low at the beginning of the Start condition (Figure 31-33).
- SCL is sampled low before SDA is asserted low (Figure 31-34).

During a Start condition, both the SDA and the SCL pins are monitored.

If the SDA pin is already low, or the SCL pin is already low, then all of the following occur:

- the Start condition is aborted,
- the BCL1IF flag is set and
- the MSSP module is reset to its Idle state (Figure 31-33).

The Start condition begins with the SDA and SCL pins deasserted. When the SDA pin is sampled high, the Baud Rate Generator is loaded and counts down. If the SCL pin is sampled low while SDA is high, a bus collision occurs because it is assumed that another master is attempting to drive a data '1' during the Start condition.

If the SDA pin is sampled low during this count, the BRG is reset and the SDA line is asserted early (Figure 31-35). If, however, a '1' is sampled on the SDA pin, the SDA pin is asserted low at the end of the BRG count. The Baud Rate Generator is then reloaded and counts down to zero; if the SCL pin is sampled as '0' during this time, a bus collision does not occur. At the end of the BRG count, the SCL pin is asserted low.

Note: The reason that bus collision is not a factor during a Start condition is that no two bus masters can assert a Start condition at the exact same time. Therefore, one master will always assert SDA before the other. This condition does not cause a bus collision because the two masters must be allowed to arbitrate the first address following the Start condition. If the address is the same, arbitration must be allowed to continue into the data portion, Repeated Start or Stop conditions.

FIGURE 31-33: BUS COLLISION DURING START CONDITION (SDA ONLY)

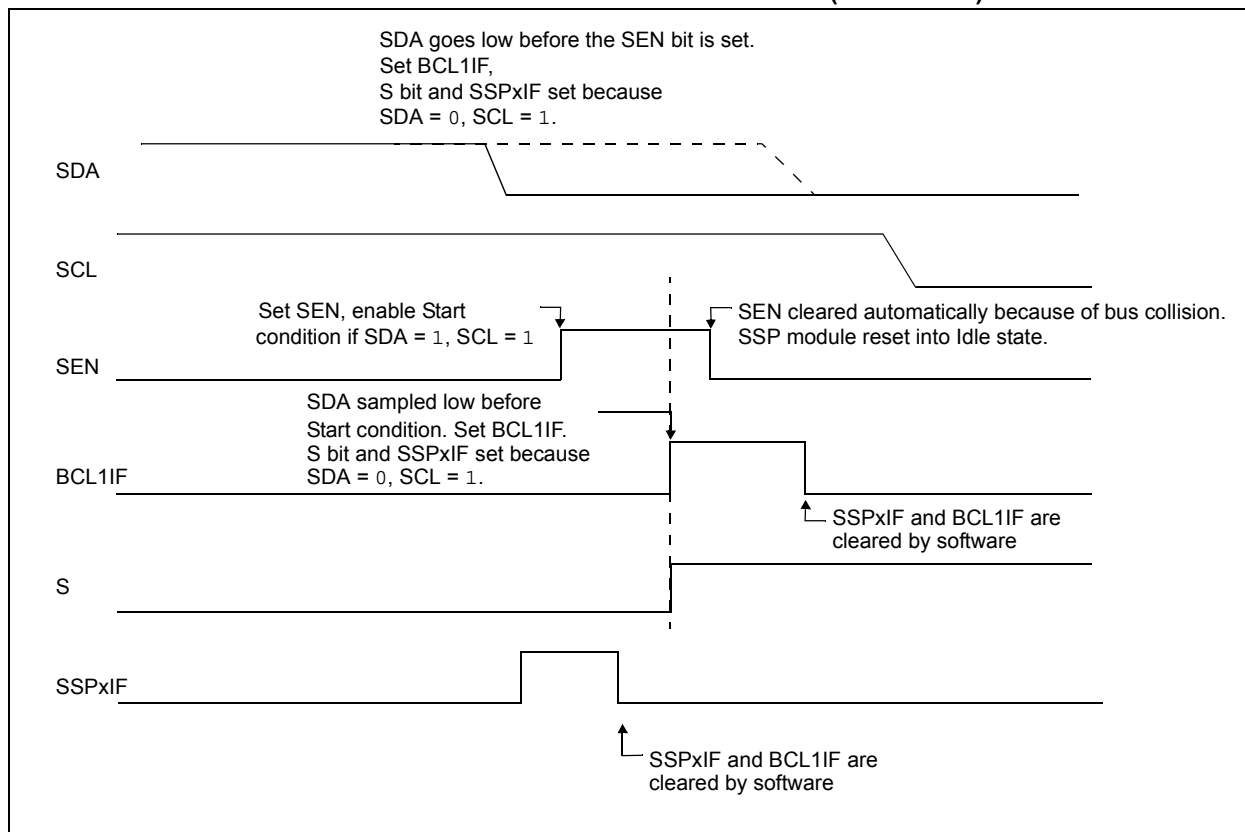

PIC16(L)F18856/76

FIGURE 31-34: BUS COLLISION DURING START CONDITION (SCL = 0)

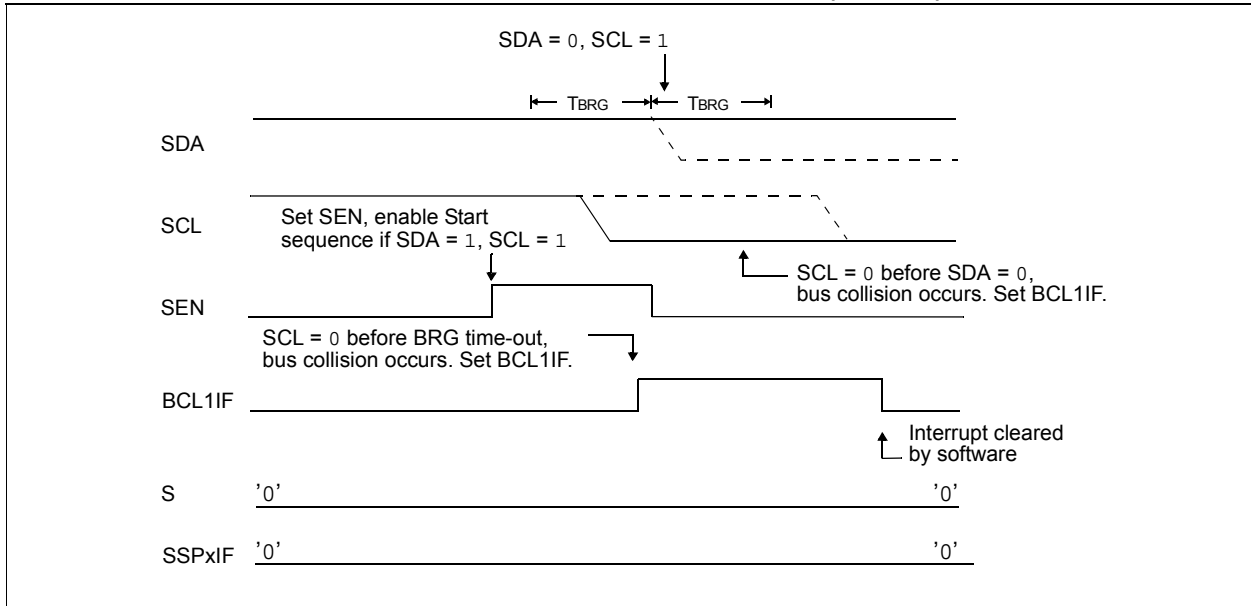
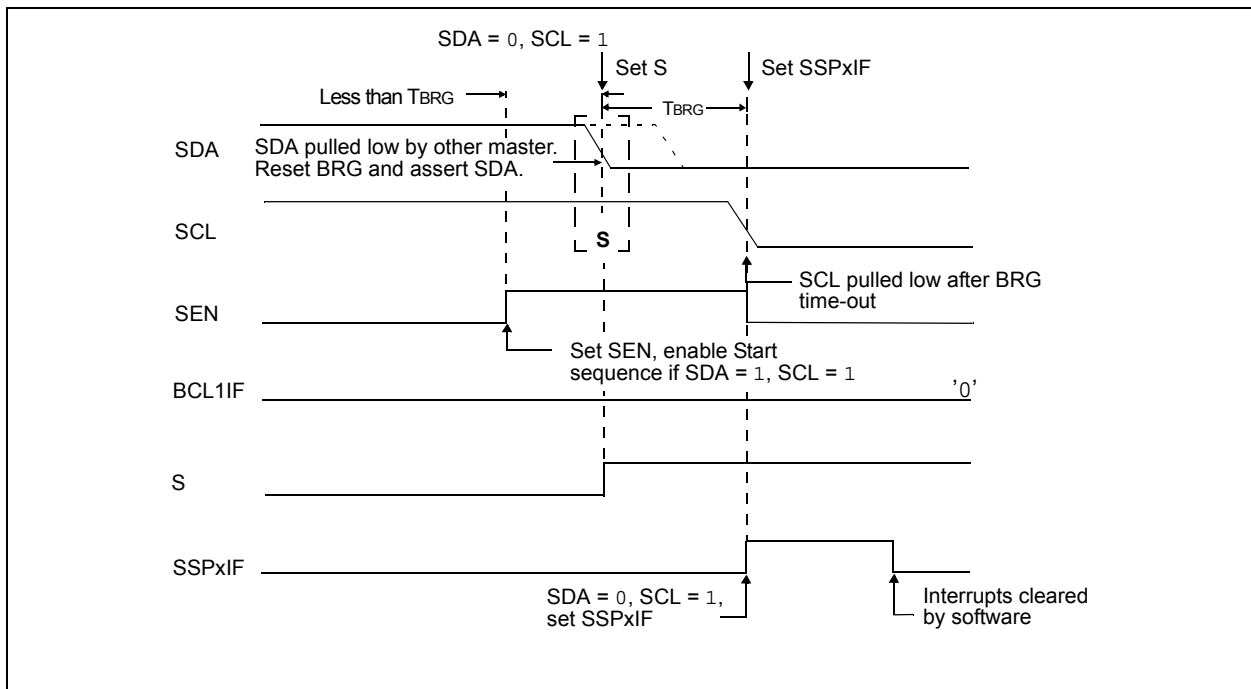

FIGURE 31-35: BRG RESET DUE TO SDA ARBITRATION DURING START CONDITION



PIC16(L)F18856/76

31.6.13.2 Bus Collision During a Repeated Start Condition

During a Repeated Start condition, a bus collision occurs if:

- A low level is sampled on SDA when SCL goes from low level to high level (Case 1).
- SCL goes low before SDA is asserted low, indicating that another master is attempting to transmit a data '1' (Case 2).

When the user releases SDA and the pin is allowed to float high, the BRG is loaded with SSPxADD and counts down to zero. The SCL pin is then deasserted and when sampled high, the SDA pin is sampled.

If SDA is low, a bus collision has occurred (i.e., another master is attempting to transmit a data '0', [Figure 31-36](#)). If SDA is sampled high, the BRG is reloaded and begins

counting. If SDA goes from high-to-low before the BRG times out, no bus collision occurs because no two masters can assert SDA at exactly the same time.

If SCL goes from high-to-low before the BRG times out and SDA has not already been asserted, a bus collision occurs. In this case, another master is attempting to transmit a data '1' during the Repeated Start condition, see [Figure 31-37](#).

If, at the end of the BRG time-out, both SCL and SDA are still high, the SDA pin is driven low and the BRG is reloaded and begins counting. At the end of the count, regardless of the status of the SCL pin, the SCL pin is driven low and the Repeated Start condition is complete.

FIGURE 31-36: BUS COLLISION DURING A REPEATED START CONDITION (CASE 1)

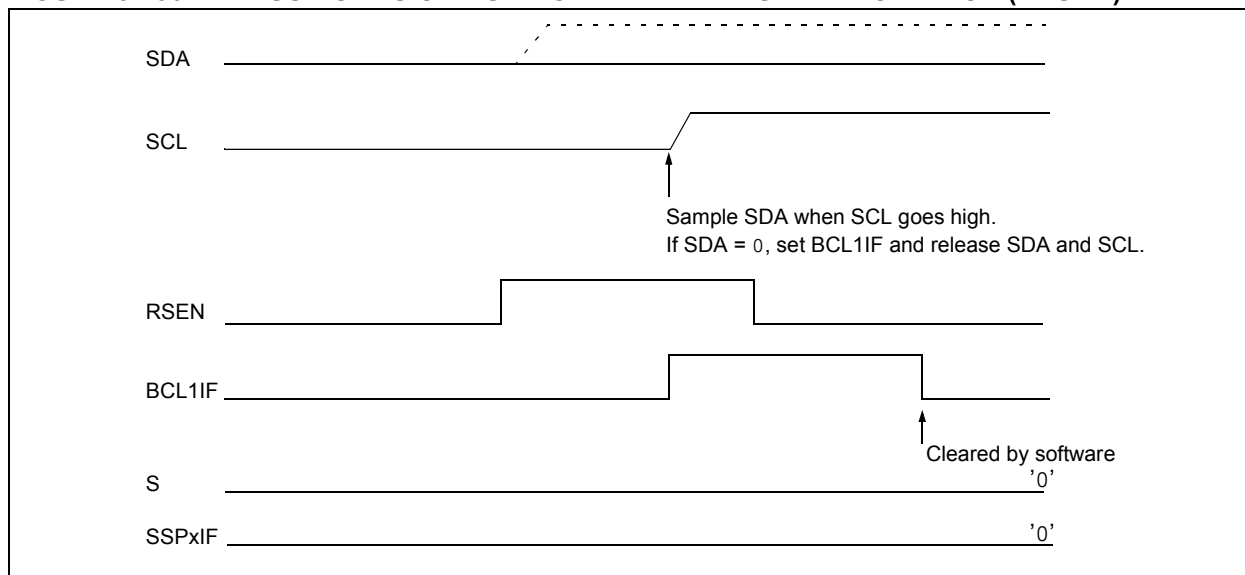
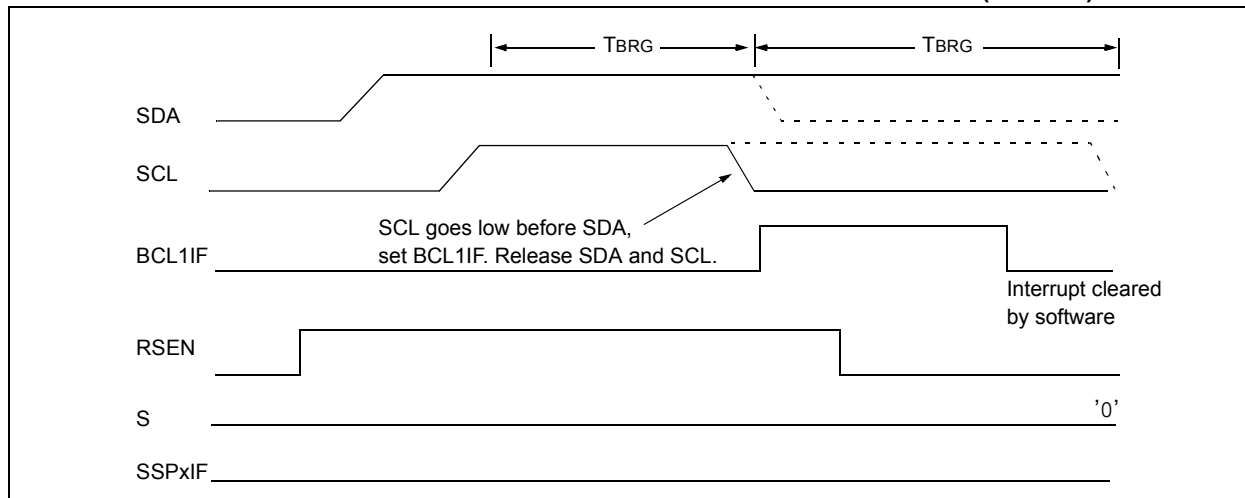

FIGURE 31-37: BUS COLLISION DURING REPEATED START CONDITION (CASE 2)



PIC16(L)F18856/76

31.6.13.3 Bus Collision During a Stop Condition

Bus collision occurs during a Stop condition if:

- After the SDA pin has been deasserted and allowed to float high, SDA is sampled low after the BRG has timed out (Case 1).
- After the SCL pin is deasserted, SCL is sampled low before SDA goes high (Case 2).

The Stop condition begins with SDA asserted low. When SDA is sampled low, the SCL pin is allowed to float. When the pin is sampled high (clock arbitration), the Baud Rate Generator is loaded with SSPxADD and counts down to zero. After the BRG times out, SDA is sampled. If SDA is sampled low, a bus collision has occurred. This is due to another master attempting to drive a data '0' (Figure 31-38). If the SCL pin is sampled low before SDA is allowed to float high, a bus collision occurs. This is another case of another master attempting to drive a data '0' (Figure 31-39).

FIGURE 31-38: BUS COLLISION DURING A STOP CONDITION (CASE 1)

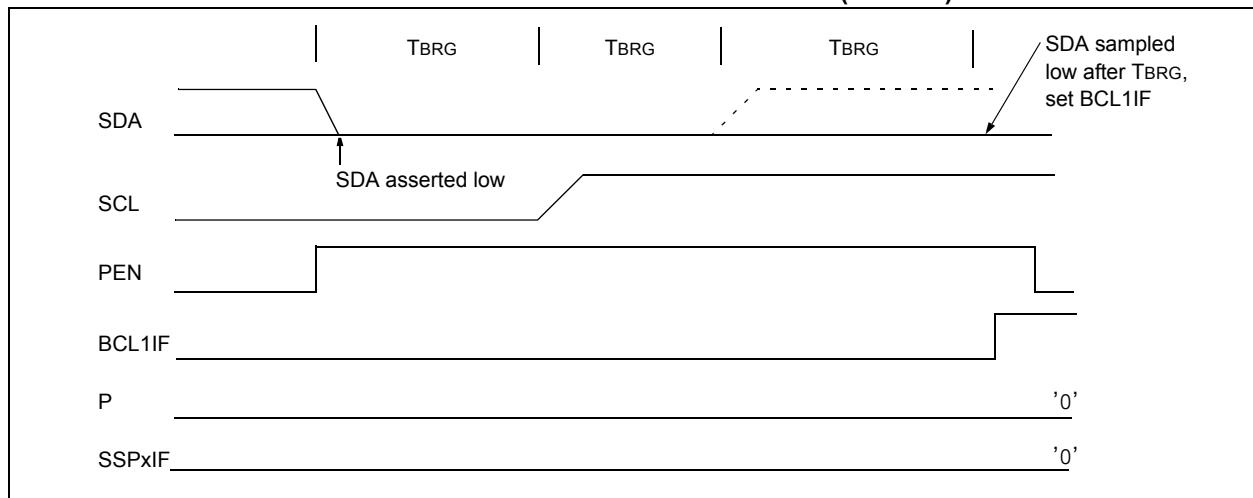
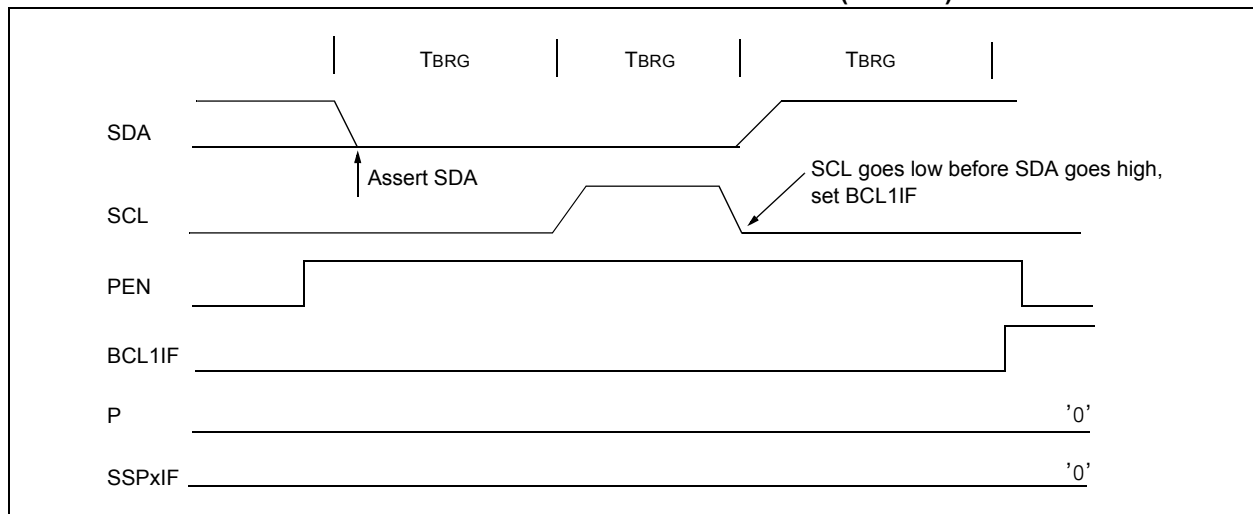

FIGURE 31-39: BUS COLLISION DURING A STOP CONDITION (CASE 2)



PIC16(L)F18856/76

31.7 BAUD RATE GENERATOR

The MSSP module has a Baud Rate Generator available for clock generation in both I²C and SPI Master modes. The Baud Rate Generator (BRG) reload value is placed in the SSPxADD register (Register 31-6). When a write occurs to SSPxBUF, the Baud Rate Generator will automatically begin counting down.

Once the given operation is complete, the internal clock will automatically stop counting and the clock pin will remain in its last state.

An internal signal “Reload” in Figure 31-40 triggers the value from SSPxADD to be loaded into the BRG counter. This occurs twice for each oscillation of the

module clock line. The logic dictating when the reload signal is asserted depends on the mode the MSSP is being operated in.

Table 31-2 demonstrates clock rates based on instruction cycles and the BRG value loaded into SSPxADD.

EQUATION 31-1:

$$F_{CLOCK} = \frac{F_{OSC}}{(SSP1ADD + 1)(4)}$$

FIGURE 31-40: BAUD RATE GENERATOR BLOCK DIAGRAM

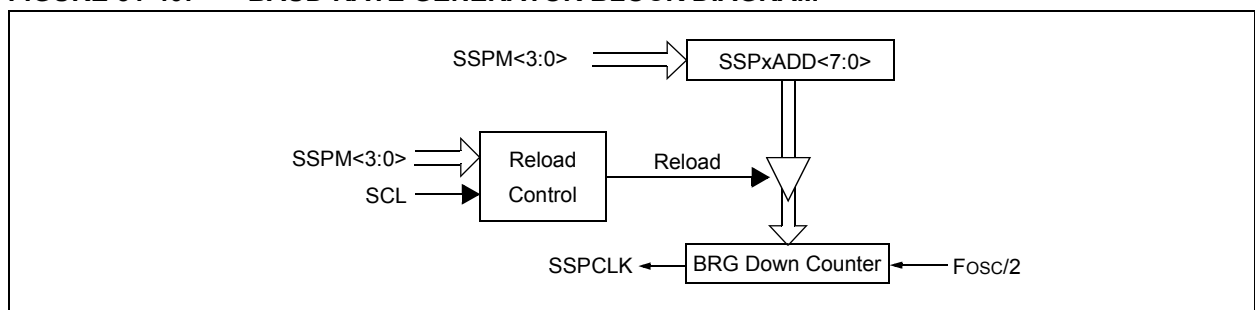

Note: Values of 0x00, 0x01 and 0x02 are not valid for SSPxADD when used as a Baud Rate Generator for I²C. This is an implementation limitation.

TABLE 31-2: MSSP CLOCK RATE W/BRG

Fosc	Fcy	BRG Value	F _{CLOCK} (2 Rollovers of BRG)
32 MHz	8 MHz	13h	400 kHz
32 MHz	8 MHz	19h	308 kHz
32 MHz	8 MHz	4Fh	100 kHz
16 MHz	4 MHz	09h	400 kHz
16 MHz	4 MHz	0Ch	308 kHz
16 MHz	4 MHz	27h	100 kHz
4 MHz	1 MHz	09h	100 kHz

Note: Refer to the I/O port electrical specifications in Table 37-4 to ensure the system is designed to support IOL requirements.

PIC16(L)F18856/76

31.8 Register Definitions: MSSPx Control

REGISTER 31-1: SSPxSTAT: SSPx STATUS REGISTER

R/W-0/0	R/W-0/0	R/HS/HC-0	R/HS/HC-0	R/HS/HC-0	R/HS/HC-0	R/HS/HC-0	R/HS/HC-0
SMP	CKE ⁽¹⁾	D/A	P ⁽²⁾	S ⁽²⁾	R/W	UA	BF
bit 7							bit 0

Legend:

R = Readable bit	W = Writable bit	U = Unimplemented bit, read as '0'
u = Bit is unchanged	x = Bit is unknown	-n/n = Value at POR and BOR/Value at all other Resets
'1' = Bit is set	'0' = Bit is cleared	HS/HC = Hardware set/clear

bit 7	<p>SMP: SPI Data Input Sample bit</p> <p><u>SPI Master mode:</u></p> <p>1 = Input data sampled at end of data output time</p> <p>0 = Input data sampled at middle of data output time</p> <p><u>SPI Slave mode:</u></p> <p>SMP must be cleared when SPI is used in Slave mode</p> <p><u>In I²C Master or Slave mode:</u></p> <p>1 = Slew rate control disabled for Standard Speed mode (100 kHz and 1 MHz)</p> <p>0 = Slew rate control enabled for High-Speed mode (400 kHz)</p>
bit 6	<p>CKE: SPI Clock Edge Select bit (SPI mode only)⁽¹⁾</p> <p><u>In SPI Master or Slave mode:</u></p> <p>1 = Transmit occurs on transition from active to Idle clock state</p> <p>0 = Transmit occurs on transition from Idle to active clock state</p> <p><u>In I²C™ mode only:</u></p> <p>1 = Enable input logic so that thresholds are compliant with SMBus specification</p> <p>0 = Disable SMBus specific inputs</p>
bit 5	<p>D/A: Data/Address bit (I²C mode only)</p> <p>1 = Indicates that the last byte received or transmitted was data</p> <p>0 = Indicates that the last byte received or transmitted was address</p>
bit 4	<p>P: Stop bit⁽²⁾</p> <p>(I²C mode only. This bit is cleared when the MSSP module is disabled, SSPEN is cleared.)</p> <p>1 = Indicates that a Stop bit has been detected last (this bit is '0' on Reset)</p> <p>0 = Stop bit was not detected last</p>
bit 3	<p>S: Start bit ⁽²⁾</p> <p>(I²C mode only. This bit is cleared when the MSSP module is disabled, SSPEN is cleared.)</p> <p>1 = Indicates that a Start bit has been detected last (this bit is '0' on Reset)</p> <p>0 = Start bit was not detected last</p>
bit 2	<p>R/W: Read/Write bit information (I²C mode only)</p> <p>This bit holds the R/W bit information following the last address match. This bit is only valid from the address match to the next Start bit, Stop bit, or not ACK bit.</p> <p><u>In I²C Slave mode:</u></p> <p>1 = Read</p> <p>0 = Write</p> <p><u>In I²C Master mode:</u></p> <p>1 = Transmit is in progress</p> <p>0 = Transmit is not in progress</p> <p>OR-ing this bit with SEN, RSEN, PEN, RCEN or ACKEN will indicate if the MSSP is in IDLE mode.</p>
bit 1	<p>UA: Update Address bit (10-bit I²C mode only)</p> <p>1 = Indicates that the user needs to update the address in the SSPxADD register</p> <p>0 = Address does not need to be updated</p>
bit 0	<p>BF: Buffer Full Status bit</p> <p><u>Receive (SPI and I²C modes):</u></p> <p>1 = Receive complete, SSPxBUF is full</p> <p>0 = Receive not complete, SSPxBUF is empty</p> <p><u>Transmit (I²C mode only):</u></p> <p>1 = Data transmit in progress (does not include the ACK and Stop bits), SSPxBUF is full</p> <p>0 = Data transmit complete (does not include the ACK and Stop bits), SSPxBUF is empty</p>

- Note** 1: Polarity of clock state is set by the CKP bit of the SSPxCON register.
 2: This bit is cleared on Reset and when SSPEN is cleared.

PIC16(L)F18856/76

REGISTER 31-2: SSPxCON1: SSPx CONTROL REGISTER 1

R/C/HS-0/0	R/C/HS-0/0	R/W-0/0	R/W-0/0	R/W-0/0	R/W-0/0	R/W-0/0	R/W-0/0
WCOL	SSPOV ⁽¹⁾	SSPEN	CKP	SSPM<3:0>			
bit 7							bit 0

Legend:

R = Readable bit	W = Writable bit	U = Unimplemented bit, read as '0'
u = Bit is unchanged	x = Bit is unknown	-n/n = Value at POR and BOR/Value at all other Resets
'1' = Bit is set	'0' = Bit is cleared	HS = Bit is set by hardware C = User cleared

bit 7	<p>WCOL: Write Collision Detect bit (Transmit mode only)</p> <p>1 = The SSPxBUF register is written while it is still transmitting the previous word (must be cleared in software)</p> <p>0 = No collision</p>
bit 6	<p>SSPOV: Receive Overflow Indicator bit⁽¹⁾</p> <p><u>In SPI mode:</u></p> <p>1 = A new byte is received while the SSPxBUF register is still holding the previous data. In case of overflow, the data in SSPxSR is lost. Overflow can only occur in Slave mode. In Slave mode, the user must read the SSPxBUF, even if only transmitting data, to avoid setting overflow. In Master mode, the overflow bit is not set since each new reception (and transmission) is initiated by writing to the SSPxBUF register (must be cleared in software).</p> <p>0 = No overflow</p> <p><u>In I²C mode:</u></p> <p>1 = A byte is received while the SSPxBUF register is still holding the previous byte. SSPOV is a "don't care" in Transmit mode (must be cleared in software).</p> <p>0 = No overflow</p>
bit 5	<p>SSPEN: Synchronous Serial Port Enable bit</p> <p>In both modes, when enabled, the following pins must be properly configured as input or output</p> <p><u>In SPI mode:</u></p> <p>1 = Enables serial port and configures SCK, SDO, SDI and \overline{SS} as the source of the serial port pins⁽²⁾</p> <p>0 = Disables serial port and configures these pins as I/O port pins</p> <p><u>In I²C mode:</u></p> <p>1 = Enables the serial port and configures the SDA and SCL pins as the source of the serial port pins⁽³⁾</p> <p>0 = Disables serial port and configures these pins as I/O port pins</p>
bit 4	<p>CKP: Clock Polarity Select bit</p> <p><u>In SPI mode:</u></p> <p>1 = Idle state for clock is a high level</p> <p>0 = Idle state for clock is a low level</p> <p><u>In I²C Slave mode:</u></p> <p>SCL release control</p> <p>1 = Enable clock</p> <p>0 = Holds clock low (clock stretch). (Used to ensure data setup time.)</p> <p><u>In I²C Master mode:</u></p> <p>Unused in this mode</p>
bit 3-0	<p>SSPM<3:0>: Synchronous Serial Port Mode Select bits</p> <p>1111 = I²C Slave mode, 10-bit address with Start and Stop bit interrupts enabled</p> <p>1110 = I²C Slave mode, 7-bit address with Start and Stop bit interrupts enabled</p> <p>1101 = Reserved</p> <p>1100 = Reserved</p> <p>1011 = I²C firmware controlled Master mode (slave idle)</p> <p>1010 = SPI Master mode, clock = $F_{osc}/(4 * (SSPADD+1))$⁽⁵⁾</p> <p>1001 = Reserved</p> <p>1000 = I²C Master mode, clock = $F_{osc} / (4 * (SSPADD+1))$⁽⁴⁾</p> <p>0111 = I²C Slave mode, 10-bit address</p> <p>0110 = I²C Slave mode, 7-bit address</p> <p>0101 = SPI Slave mode, clock = SCK pin, \overline{SS} pin control disabled, \overline{SS} can be used as I/O pin</p> <p>0100 = SPI Slave mode, clock = SCK pin, \overline{SS} pin control enabled</p> <p>0011 = SPI Master mode, clock = $T2_match/2$</p> <p>0010 = SPI Master mode, clock = $F_{osc}/64$</p> <p>0001 = SPI Master mode, clock = $F_{osc}/16$</p> <p>0000 = SPI Master mode, clock = $F_{osc}/4$</p>

- Note**
- 1: In Master mode, the overflow bit is not set since each new reception (and transmission) is initiated by writing to the SSPxBUF register.
 - 2: When enabled, these pins must be properly configured as input or output. Use SSPxSSPPS, SSPxCLKPPS, SSPxDATPPS, and RxyPPS to select the pins.
 - 3: When enabled, the SDA and SCL pins must be configured as inputs. Use SSPxCLKPPS, SSPxDATPPS, and RxyPPS to select the pins.
 - 4: SSPxADD values of 0, 1 or 2 are not supported for I²C mode.
 - 5: SSPxADD value of '0' is not supported. Use SSPM = 0000 instead.

PIC16(L)F18856/76

REGISTER 31-3: SSPxCON2: SSPx CONTROL REGISTER 2 (I²C MODE ONLY)⁽¹⁾

R/W-0/0	R/HS/HC-0	R/W-0/0	R/S/HC-0/0	R/S/HC-0/0	R/S/HC-0/0	R/S/HC-0/0	R/S/HC-0/0
GCEN	ACKSTAT	ACKDT	ACKEN	RCEN	PEN	RSEN	SEN
bit 7							bit 0

Legend:

R = Readable bit	W = Writable bit	U = Unimplemented bit, read as '0'
u = Bit is unchanged	x = Bit is unknown	-n/n = Value at POR and BOR/Value at all other Resets
'1' = Bit is set	'0' = Bit is cleared	HC = Cleared by hardware S = User set

- bit 7 **GCEN:** General Call Enable bit (in I²C Slave mode only)
 1 = Enable interrupt when a general call address (0x00 or 00h) is received in the SSPxSR
 0 = General call address disabled
- bit 6 **ACKSTAT:** Acknowledge Status bit (in I²C mode only)
 1 = Acknowledge was not received
 0 = Acknowledge was received
- bit 5 **ACKDT:** Acknowledge Data bit (in I²C mode only)
In Receive mode:
 Value transmitted when the user initiates an Acknowledge sequence at the end of a receive
 1 = Not Acknowledge
 0 = Acknowledge
- bit 4 **ACKEN:** Acknowledge Sequence Enable bit (in I²C Master mode only)
In Master Receive mode:
 1 = Initiate Acknowledge sequence on SDA and SCL pins, and transmit ACKDT data bit.
 Automatically cleared by hardware.
 0 = Acknowledge sequence idle
- bit 3 **RCEN:** Receive Enable bit (in I²C Master mode only)
 1 = Enables Receive mode for I²C
 0 = Receive idle
- bit 2 **PEN:** Stop Condition Enable bit (in I²C Master mode only)
SCKMSSP Release Control:
 1 = Initiate Stop condition on SDA and SCL pins. Automatically cleared by hardware.
 0 = Stop condition Idle
- bit 1 **RSEN:** Repeated Start Condition Enable bit (in I²C Master mode only)
 1 = Initiate Repeated Start condition on SDA and SCL pins. Automatically cleared by hardware.
 0 = Repeated Start condition Idle
- bit 0 **SEN:** Start Condition Enable/Stretch Enable bit
In Master mode:
 1 = Initiate Start condition on SDA and SCL pins. Automatically cleared by hardware.
 0 = Start condition Idle
In Slave mode:
 1 = Clock stretching is enabled for both slave transmit and slave receive (stretch enabled)
 0 = Clock stretching is disabled

Note 1: For bits ACKEN, RCEN, PEN, RSEN, SEN: If the I²C module is not in the IDLE mode, this bit may not be set (no spooling) and the SSPxBUF may not be written (or writes to the SSPxBUF are disabled).

PIC16(L)F18856/76

REGISTER 31-4: SSPxCON3: SSPx CONTROL REGISTER 3

R-0/0	R/W-0/0	R/W-0/0	R/W-0/0	R/W-0/0	R/W-0/0	R/W-0/0	R/W-0/0
ACKTIM ⁽³⁾	PCIE	SCIE	BOEN	SDAHT	SBCDE	AHEN	DHEN
bit 7							bit 0

Legend:

R = Readable bit	W = Writable bit	U = Unimplemented bit, read as '0'
u = Bit is unchanged	x = Bit is unknown	-n/n = Value at POR and BOR/Value at all other Resets
'1' = Bit is set	'0' = Bit is cleared	

- bit 7 **ACKTIM:** Acknowledge Time Status bit (I²C mode only)⁽³⁾
 1 = Indicates the I²C bus is in an Acknowledge sequence, set on 8th falling edge of SCL clock
 0 = Not an Acknowledge sequence, cleared on 9th rising edge of SCL clock
- bit 6 **PCIE:** Stop Condition Interrupt Enable bit (I²C Slave mode only)
 1 = Enable interrupt on detection of Stop condition
 0 = Stop detection interrupts are disabled⁽²⁾
- bit 5 **SCIE:** Start Condition Interrupt Enable bit (I²C Slave mode only)
 1 = Enable interrupt on detection of Start or Restart conditions
 0 = Start detection interrupts are disabled⁽²⁾
- bit 4 **BOEN:** Buffer Overwrite Enable bit
In SPI Slave mode:⁽¹⁾
 1 = SSPxBUF updates every time that a new data byte is shifted in ignoring the BF bit
 0 = If new byte is received with BF bit of the SSPxSTAT register already set, SSPOV bit of the SSPxCON1 register is set, and the buffer is not updated
In I²C™ Master mode and SPI Master mode:
 This bit is ignored.
In I²C™ Slave mode:
 1 = SSPxBUF is updated and \overline{ACK} is generated for a received address/data byte, ignoring the state of the SSPOV bit only if the BF bit = 0.
 0 = SSPxBUF is only updated when SSPOV is clear
- bit 3 **SDAHT:** SDA Hold Time Selection bit (I²C mode only)
 1 = Minimum of 300 ns hold time on SDA after the falling edge of SCL
 0 = Minimum of 100 ns hold time on SDA after the falling edge of SCL
- bit 2 **SBCDE:** Slave Mode Bus Collision Detect Enable bit (I²C Slave mode only)
 If, on the rising edge of SCL, SDA is sampled low when the module is outputting a high state, the BCL1IF bit of the PIR3 register is set, and bus goes idle
 1 = Enable slave bus collision interrupts
 0 = Slave bus collision interrupts are disabled
- bit 1 **AHEN:** Address Hold Enable bit (I²C Slave mode only)
 1 = Following the eighth falling edge of SCL for a matching received address byte; CKP bit of the SSPxCON1 register will be cleared and the SCL will be held low.
 0 = Address holding is disabled
- bit 0 **DHEN:** Data Hold Enable bit (I²C Slave mode only)
 1 = Following the eighth falling edge of SCL for a received data byte; slave hardware clears the CKP bit of the SSPxCON1 register and SCL is held low.
 0 = Data holding is disabled

- Note 1:** For daisy-chained SPI operation; allows the user to ignore all but the last received byte. SSPOV is still set when a new byte is received and BF = 1, but hardware continues to write the most recent byte to SSPxBUF.
- 2:** This bit has no effect in Slave modes that Start and Stop condition detection is explicitly listed as enabled.
- 3:** The ACKTIM Status bit is only active when the AHEN bit or DHEN bit is set.

PIC16(L)F18856/76

REGISTER 31-5: SSPxMSK: SSPx MASK REGISTER

R/W-1/1	R/W-1/1	R/W-1/1	R/W-1/1	R/W-1/1	R/W-1/1	R/W-1/1	R/W-1/1
SSPMSK<7:0>							
bit 7							bit 0

Legend:

R = Readable bit	W = Writable bit	U = Unimplemented bit, read as '0'
u = Bit is unchanged	x = Bit is unknown	-n/n = Value at POR and BOR/Value at all other Resets
'1' = Bit is set	'0' = Bit is cleared	

- bit 7-1 **SSPMSK<7:1>**: Mask bits
 1 = The received address bit n is compared to SSPxADD<n> to detect I²C address match
 0 = The received address bit n is not used to detect I²C address match
- bit 0 **SSPMSK<0>**: Mask bit for I²C Slave mode, 10-bit Address
I²C Slave mode, 10-bit address (SSPM<3:0> = 0111 or 1111):
 1 = The received address bit 0 is compared to SSPxADD<0> to detect I²C address match
 0 = The received address bit 0 is not used to detect I²C address match
I²C Slave mode, 7-bit address:
 MSK0 bit is ignored.

REGISTER 31-6: SSPxADD: MSSPx ADDRESS AND BAUD RATE REGISTER (I²C MODE)

R/W-0/0	R/W-0/0	R/W-0/0	R/W-0/0	R/W-0/0	R/W-0/0	R/W-0/0	R/W-0/0
SSPADD<7:0>							
bit 7							bit 0

Legend:

R = Readable bit	W = Writable bit	U = Unimplemented bit, read as '0'
u = Bit is unchanged	x = Bit is unknown	-n/n = Value at POR and BOR/Value at all other Resets
'1' = Bit is set	'0' = Bit is cleared	

Master mode:

- bit 7-0 **SSPADD<7:0>**: Baud Rate Clock Divider bits
 $SCL \text{ pin clock period} = ((ADD<7:0> + 1) * 4) / F_{osc}$

10-Bit Slave mode – Most Significant Address Byte:

- bit 7-3 **Not used:** Unused for Most Significant Address Byte. Bit state of this register is a “don't care”. Bit pattern sent by master is fixed by I²C specification and must be equal to '11110'. However, those bits are compared by hardware and are not affected by the value in this register.
- bit 2-1 **SSPADD<2:1>**: Two Most Significant bits of 10-bit Address
- bit 0 **Not used:** Unused in this mode. Bit state is a “don't care”.

10-Bit Slave mode – Least Significant Address Byte:

- bit 7-0 **SSPADD<7:0>**: Eight Least Significant bits of 10-bit Address

7-Bit Slave mode:

- bit 7-1 **SSPADD<7:1>**: 7-bit Address
- bit 0 **Not used:** Unused in this mode. Bit state is a “don't care”.

PIC16(L)F18856/76

REGISTER 31-7: SSPxBUF: MSSPx BUFFER REGISTER

R/W-x	R/W-x	R/W-x	R/W-x	R/W-x	R/W-x	R/W-x	R/W-x
SSPBUF<7:0>							
bit 7							bit 0

Legend:

R = Readable bit	W = Writable bit	U = Unimplemented bit, read as '0'
u = Bit is unchanged	x = Bit is unknown	-n/n = Value at POR and BOR/Value at all other Resets
'1' = Bit is set	'0' = Bit is cleared	

bit 7-0 **SSPBUF<7:0>**: MSSP Buffer bits

TABLE 31-3: SUMMARY OF REGISTERS ASSOCIATED WITH MSSPx

Name	Bit 7	Bit 6	Bit 5	Bit 4	Bit 3	Bit 2	Bit 1	Bit 0	Register on Page
INTCON	GIE	PEIE	—	—	—	—	—	INTEDG	134
PIR3	—	—	RCIF	TXIF	BCL2IF	SSP2IF	BCL1IF	SSP1IF	147
PIE3	—	—	RCIE	TXIE	BCL2IE	SSP2IE	BCL1IE	SSP1IE	138
SSP1STAT	SMP	CKE	D \bar{A}	P	S	R \bar{W}	UA	BF	503
SSP1CON1	WCOL	SSPOV	SSPEN	CKP	SSPM<3:0>				504
SSP1CON2	GCEN	ACKSTAT	ACKDT	ACKEN	RCEN	PEN	RSEN	SEN	505
SSP1CON3	ACKTIM	PCIE	SCIE	BOEN	SDAHT	SBCDE	AHEN	DHEN	503
SSP1MSK	SSPMSK<7:0>								507
SSP1ADD	SSPADD<7:0>								507
SSP1BUF	SSPBUF<7:0>								508
SSP2STAT	SMP	CKE	D \bar{A}	P	S	R \bar{W}	UA	BF	503
SSP2CON1	WCOL	SSPOV	SSPEN	CKP	SSPM<3:0>				504
SSP2CON2	GCEN	ACKSTAT	ACKDT	ACKEN	RCEN	PEN	RSEN	SEN	505
SSP2CON3	ACKTIM	PCIE	SCIE	BOEN	SDAHT	SBCDE	AHEN	DHEN	503
SSP2MSK	SSPMSK<7:0>								507
SSP2ADD	SSPADD<7:0>								507
SSP2BUF	SSPBUF<7:0>								508
SSP1CLKPPS	—	—	—	SSP1CLKPPS<4:0>					249
SSP1DATPPS	—	—	—	SSP1DATPPS<4:0>					249
SSP1SSPPS	—	—	—	SSP1SSPPS<4:0>					249
SSP2CLKPPS	—	—	—	SSP2CLKPPS<4:0>					249
SSP2DATPPS	—	—	—	SSP2DATPPS<4:0>					249
SSP2SSPPS	—	—	—	SSP2SSPPS<4:0>					249
RxyPPS	—	—	—	RxyPPS<4:0>					250

Legend: — = Unimplemented location, read as '0'. Shaded cells are not used by the MSSPx module

Note 1: When using designated I²C pins, the associated pin values in INLV_{Lx} will be ignored.

PIC16(L)F18856/76

32.0 SIGNAL MEASUREMENT TIMER (SMT)

The SMT is a 24-bit counter with advanced clock and gating logic, which can be configured for measuring a variety of digital signal parameters such as pulse width, frequency and duty cycle, and the time difference between edges on two signals.

Features of the SMT include:

- 24-bit timer/counter
 - Three 8-bit registers (SMTxL/H/U)
 - Readable and writable
 - Optional 16-bit operating mode
- Two 24-bit measurement capture registers
- One 24-bit period match register
- Multi-mode operation, including relative timing measurement
- Interrupt on period match
- Multiple clock, gate and signal sources
- Interrupt on acquisition complete
- Ability to read current input values

<p>Note: These devices implement two SMT modules. All references to SMTx apply to SMT1 and SMT2.</p>

PIC16(L)F18856/76

FIGURE 32-1: SMT BLOCK DIAGRAM

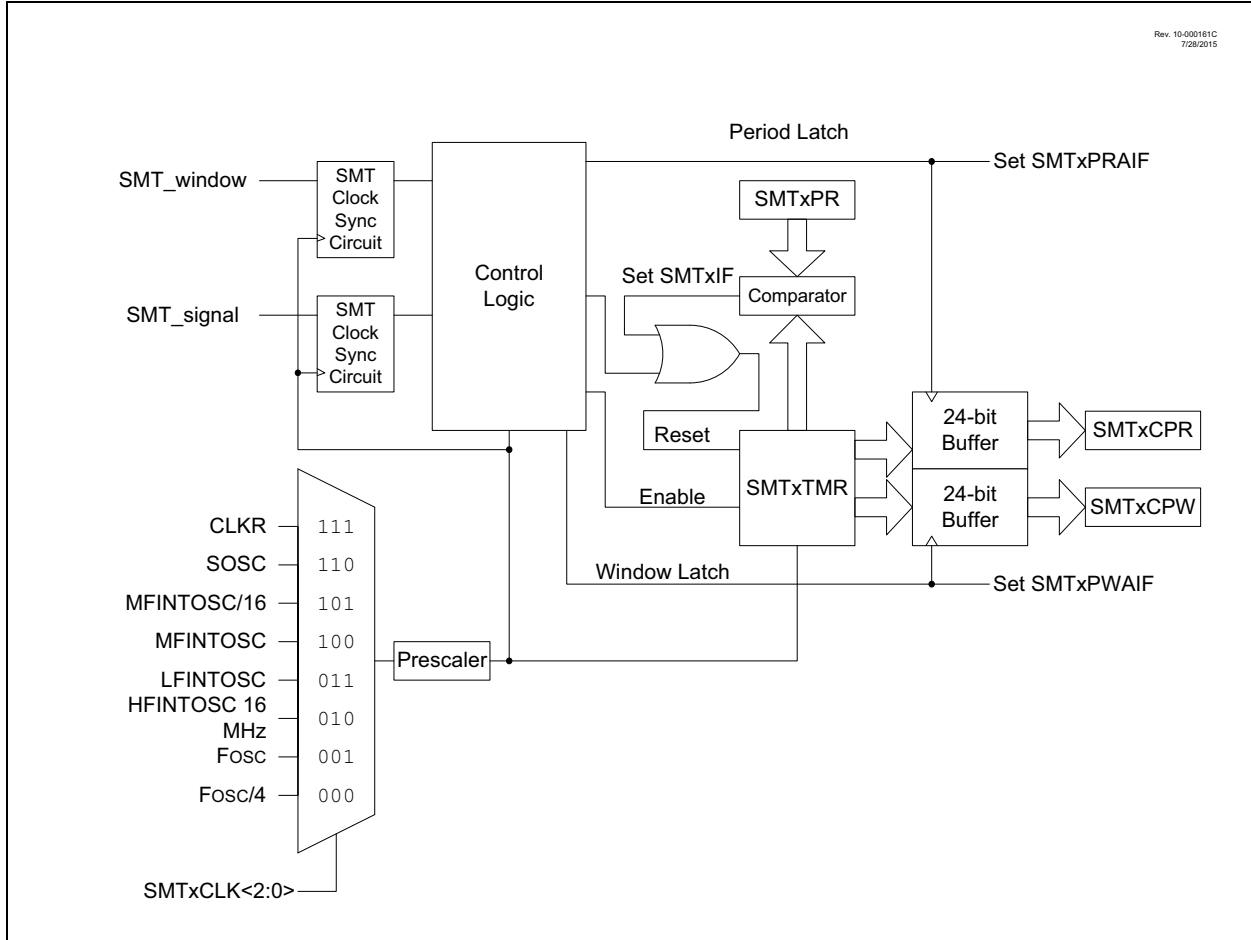
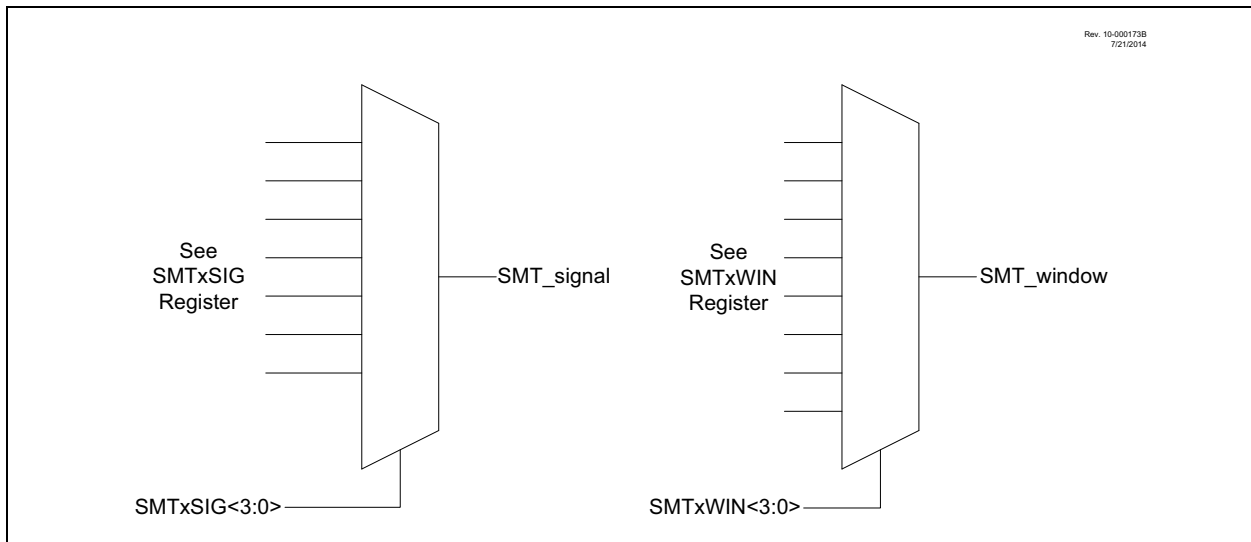

FIGURE 32-2: SMT SIGNAL AND WINDOW BLOCK DIAGRAM



PIC16(L)F18856/76

32.1 SMT Operation

The core of the module is the 24-bit counter, SMTxTMR combined with a complex data acquisition front-end. Depending on the mode of operation selected, the SMT can perform a variety of measurements summarized in [Table 32-1](#).

32.1.1 CLOCK SOURCES

Clock sources available to the SMT include:

- FOSC
- FOSC/4
- HFINTOSC (16 MHz)
- LFINTOSC
- MFINTOSC/16 (31.25 kHz)

The SMT clock source is selected by configuring the CSEL<2:0> bits in the SMTxCLK register. The clock source can also be prescaled using the PS<1:0> bits of the SMTxCON0 register. The prescaled clock source is used to clock both the counter and any synchronization logic used by the module.

32.1.2 PERIOD MATCH INTERRUPT

Similar to other timers, the SMT triggers an interrupt when SMTxTMR rolls over to '0'. This happens when SMTxTMR = SMTxPR, regardless of mode. Hence, in any mode that relies on an external signal or a window to reset the timer, proper operation requires that SMTxPR be set to a period larger than that of the expected signal or window.

32.2 Basic Timer Function Registers

The SMTxTMR time base and the SMTxCPW/SMTxPR/SMTxCPR buffer registers serve several functions and can be manually updated using software.

32.2.1 TIME BASE

The SMTxTMR is the 24-bit counter that is the center of the SMT. It is used as the basic counter/timer for measurement in each of the modes of the SMT. It can be reset to a value of 24'h00_0000 by setting the RST bit of the SMTxSTAT register. It can be written to and read from software, but it is not guarded for atomic access, therefore reads and writes to the SMTxTMR should only be made when the GO = 0, or the software should have other measures to ensure integrity of SMTxTMR reads/writes.

32.2.2 PULSE WIDTH LATCH REGISTERS

The SMTxCPW registers are the 24-bit SMT pulse width latch. They are used to latch in the value of the SMTxTMR when triggered by various signals, which are determined by the mode the SMT is currently in.

The SMTxCPW registers can also be updated with the current value of the SMTxTMR value by setting the CPWUP bit of the SMTxSTAT register.

32.2.3 PERIOD LATCH REGISTERS

The SMTxCPR registers are the 24-bit SMT period latch. They are used to latch in other values of the SMTxTMR when triggered by various other signals, which are determined by the mode the SMT is currently in.

The SMTxCPR registers can also be updated with the current value of the SMTxTMR value by setting the CPRU bit in the SMTxSTAT register.

32.3 Halt Operation

The counter can be prevented from rolling-over using the STP bit in the SMTxCON0 register. When halting is enabled, the period match interrupt persists until the SMTxTMR is reset (either by a manual reset, [Section 32.2.1 "Time Base"](#)) or by clearing the SMTxGO bit of the SMTxCON1 register and writing the SMTxTMR values in software.

32.4 Polarity Control

The three input signals for the SMT have polarity control to determine whether or not they are active high/positive edge or active low/negative edge signals.

The following bits apply to Polarity Control:

- WSEL bit (Window Polarity)
- SSEL bit (Signal Polarity)
- CSEL bit (Clock Polarity)

These bits are located in the SMTxCON0 register.

32.5 Status Information

The SMT provides input status information for the user without requiring the need to deal with the polarity of the incoming signals.

32.5.1 WINDOW STATUS

Window status is determined by the WS bit of the SMTxSTAT register. This bit is only used in Windowed Measure, Gated Counter and Gated Window Measure modes, and is only valid when TS = 1, and will be delayed in time by synchronizer delays in non-Counter modes.

32.5.2 SIGNAL STATUS

Signal status is determined by the AS bit of the SMTxSTAT register. This bit is used in all modes except Window Measure, Time of Flight and Capture modes, and is only valid when TS = 1, and will be delayed in time by synchronizer delays in non-Counter modes.

PIC16(L)F18856/76

32.5.3 GO STATUS

Timer run status is determined by the TS bit of the SMTxSTAT register, and will be delayed in time by synchronizer delays in non-Counter modes.

32.6 Modes of Operation

The modes of operation are summarized in [Table 32-1](#). The following sections provide detailed descriptions, examples of how the modes can be used. Note that all waveforms assume WPOL/SPOL/CPOL = 0. When WPOL/SPOL/CPOL = 1, all SMTSIGx, SMTWINx and SMT clock signals will have a polarity opposite to that indicated. For all modes, the REPEAT bit controls whether the acquisition is repeated or single. When REPEAT = 0 (Single Acquisition mode), the timer will stop incrementing and the SMTxGO bit will be reset upon the completion of an acquisition. Otherwise, the timer will continue and allow for continued acquisitions to overwrite the previous ones until the timer is stopped in software.

32.6.1 TIMER MODE

Timer mode is the simplest mode of operation where the SMTxTMR is used as a 16/24-bit timer. No data acquisition takes place in this mode. The timer increments as long as the SMTxGO bit has been set by software. No SMT window or SMT signal events affect the SMTxGO bit. Everything is synchronized to the SMT clock source. When the timer experiences a period match (SMTxTMR = SMTxPR), SMTxTMR is reset and the period match interrupt trips. See [Figure 32-3](#).

TABLE 32-1: MODES OF OPERATION

MODE	Mode of Operation	Synchronous Operation	Reference
0000	Timer	Yes	Section 32.6.1 “Timer Mode”
0001	Gated Timer	Yes	Section 32.6.2 “Gated Timer Mode”
0010	Period and Duty Cycle Acquisition	Yes	Section 32.6.3 “Period and Duty-Cycle Mode”
0011	High and Low Time Measurement	Yes	Section 32.6.4 “High and Low Measure Mode”
0100	Windowed Measurement	Yes	Section 32.6.5 “Windowed Measure Mode”
0101	Gated Windowed Measurement	Yes	Section 32.6.6 “Gated Window Measure Mode”
0110	Time of Flight	Yes	Section 32.6.7 “Time of Flight Measure Mode”
0111	Capture	Yes	Section 32.6.8 “Capture Mode”
1000	Counter	No	Section 32.6.9 “Counter Mode”
1001	Gated Counter	No	Section 32.6.10 “Gated Counter Mode”
1010	Windowed Counter	No	Section 32.6.11 “Windowed Counter Mode”
1011-1111	Reserved	—	—

FIGURE 32-3: TIMER MODE TIMING DIAGRAM

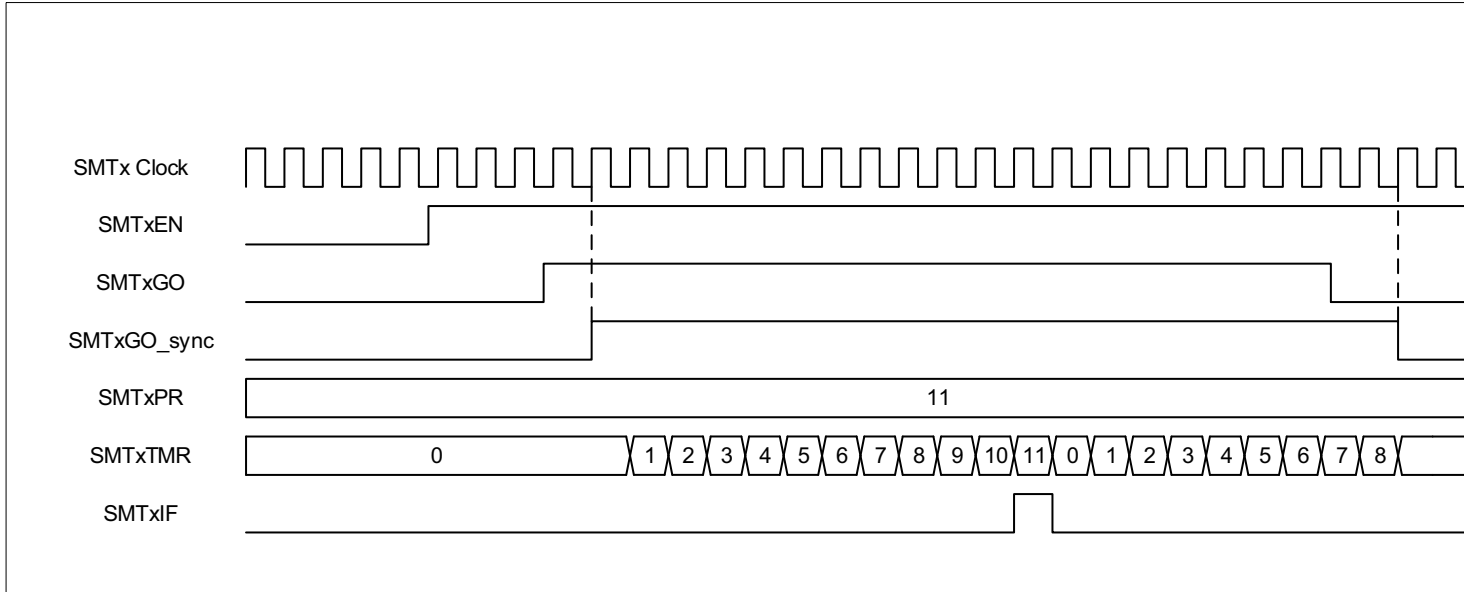

32.6.2 GATED TIMER MODE

Gated Timer mode uses the SMTSIGx input to control whether or not the SMTxTMR will increment. Upon a falling edge of the external signal, the SMTxCPW register will update to the current value of the SMTxTMR. Example waveforms for both repeated and single acquisitions are provided in [Figure 32-4](#) and [Figure 32-5](#).

FIGURE 32-4: GATED TIMER MODE REPEAT ACQUISITION TIMING DIAGRAM

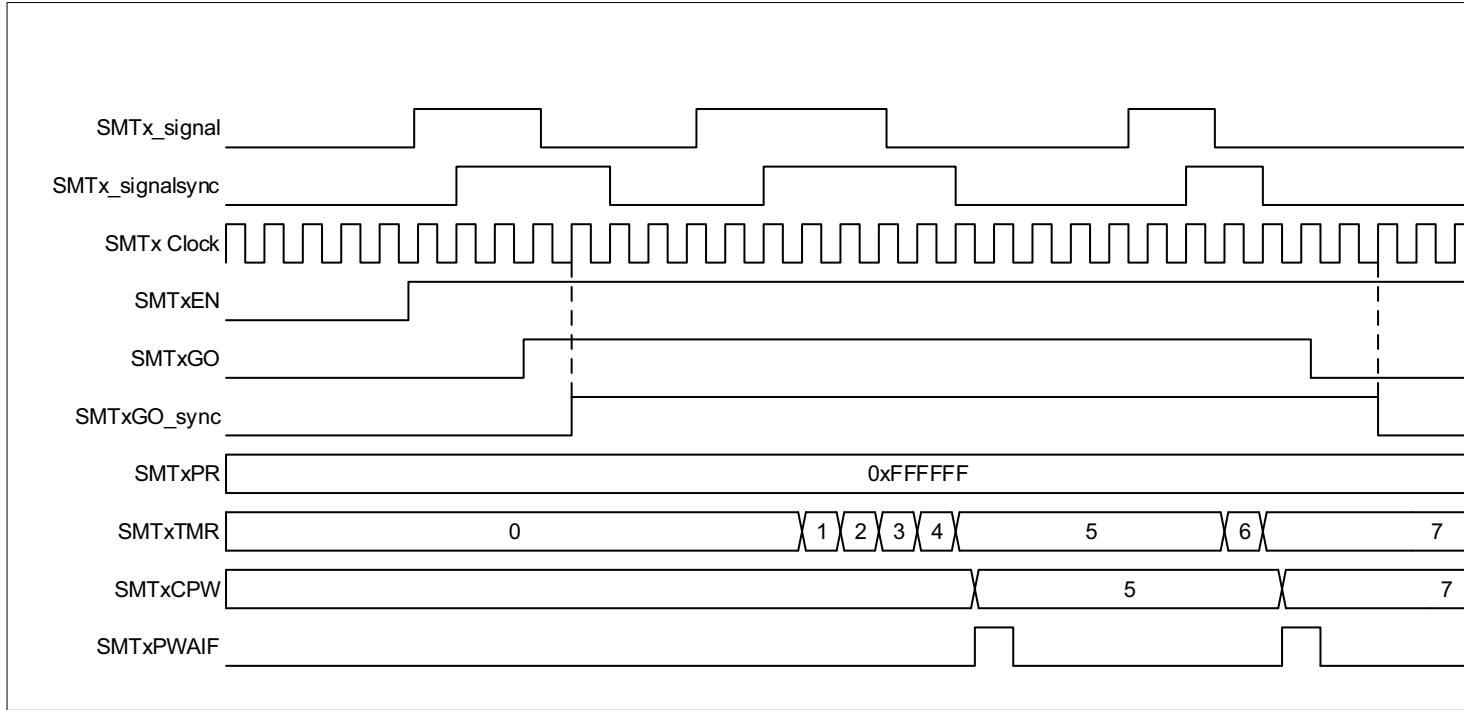
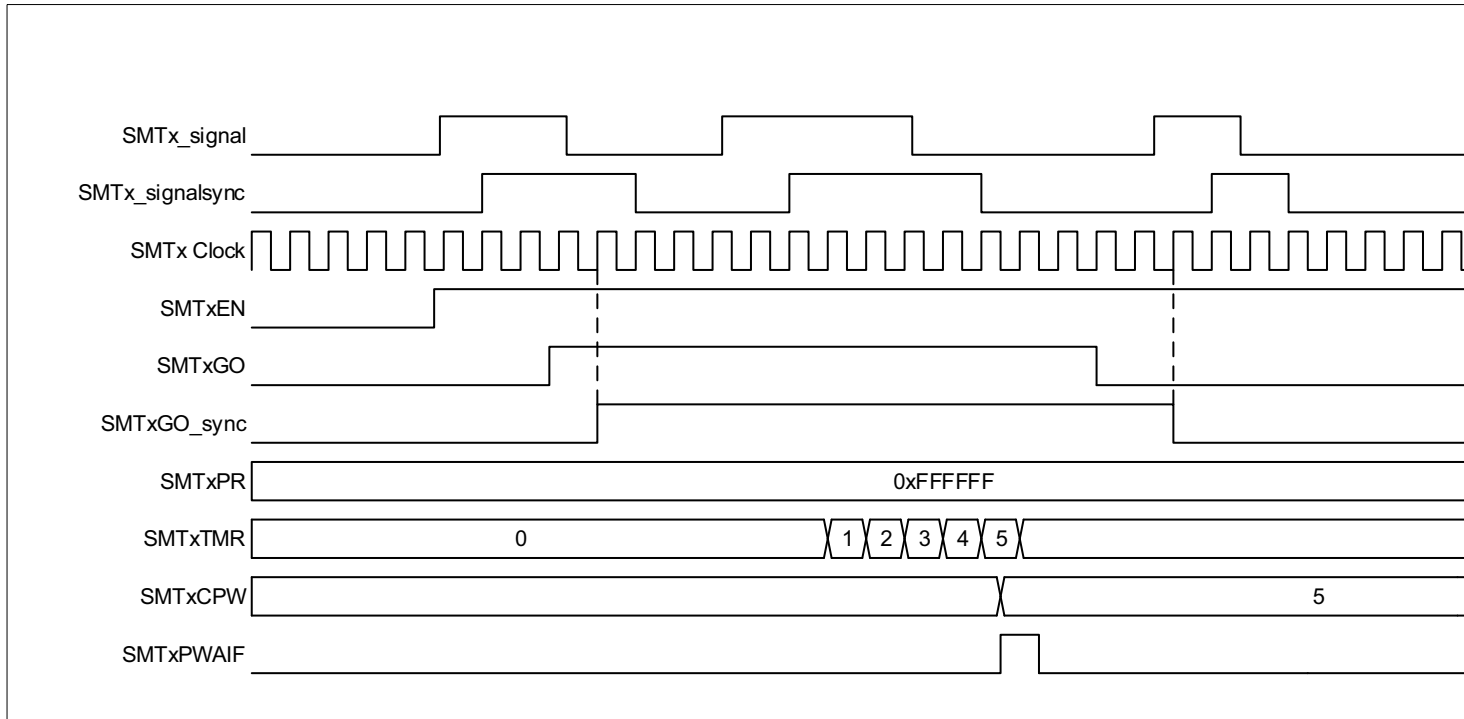

FIGURE 32-5: GATED TIMER MODE SINGLE ACQUISITION TIMING DIAGRAM



PIC16(L)F18856/76

32.6.3 PERIOD AND DUTY-CYCLE MODE

In Duty-Cycle mode, either the duty cycle or period (depending on polarity) of the SMTx_signal can be acquired relative to the SMT clock. The CPW register is updated on a falling edge of the signal, and the CPR register is updated on a rising edge of the signal, along with the SMTxTMR resetting to 0x0001. In addition, the SMTxGO bit is reset on a rising edge when the SMT is in Single Acquisition mode. See [Figure 32-6](#) and [Figure 32-7](#).

FIGURE 32-6: PERIOD AND DUTY-CYCLE REPEAT ACQUISITION MODE TIMING DIAGRAM

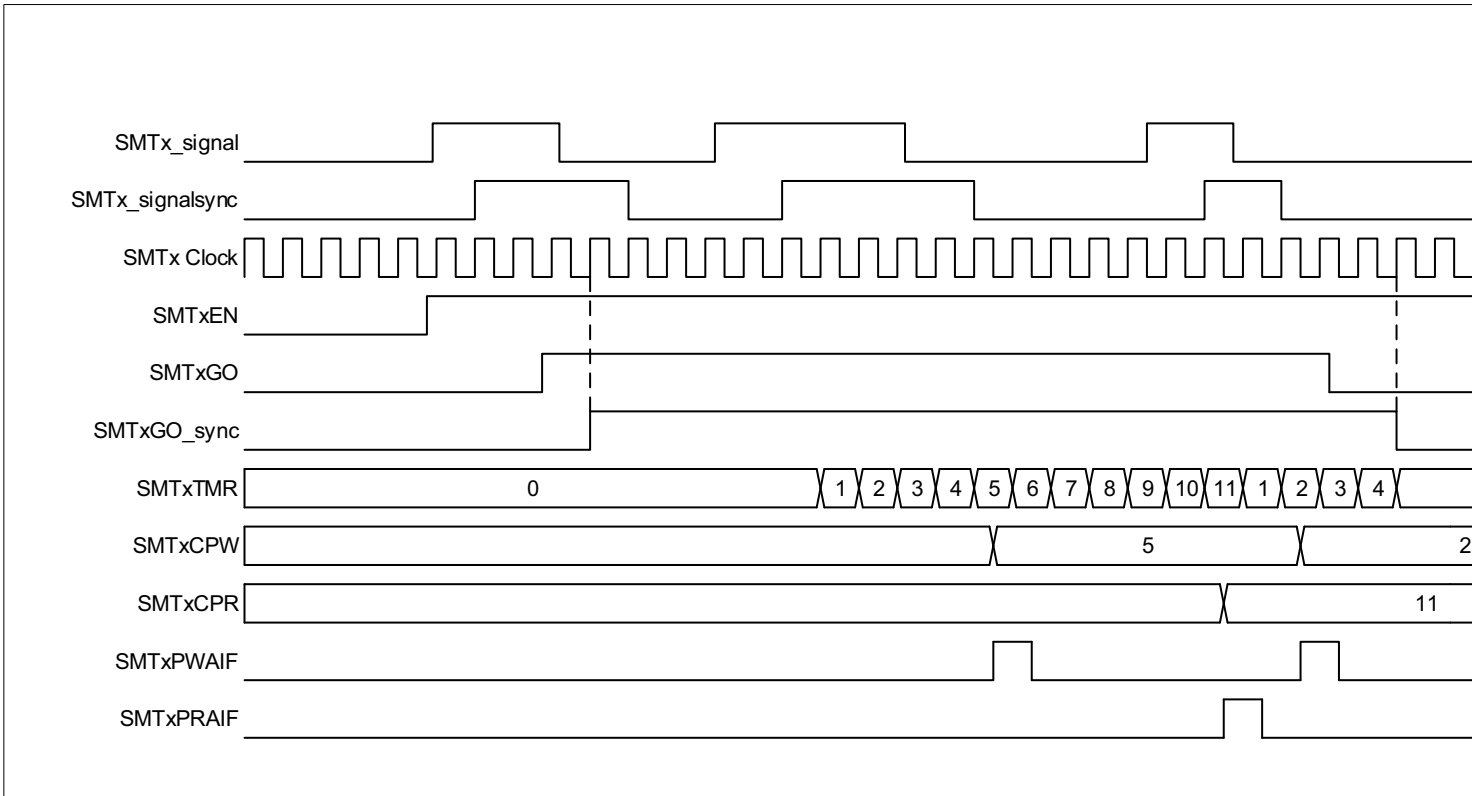
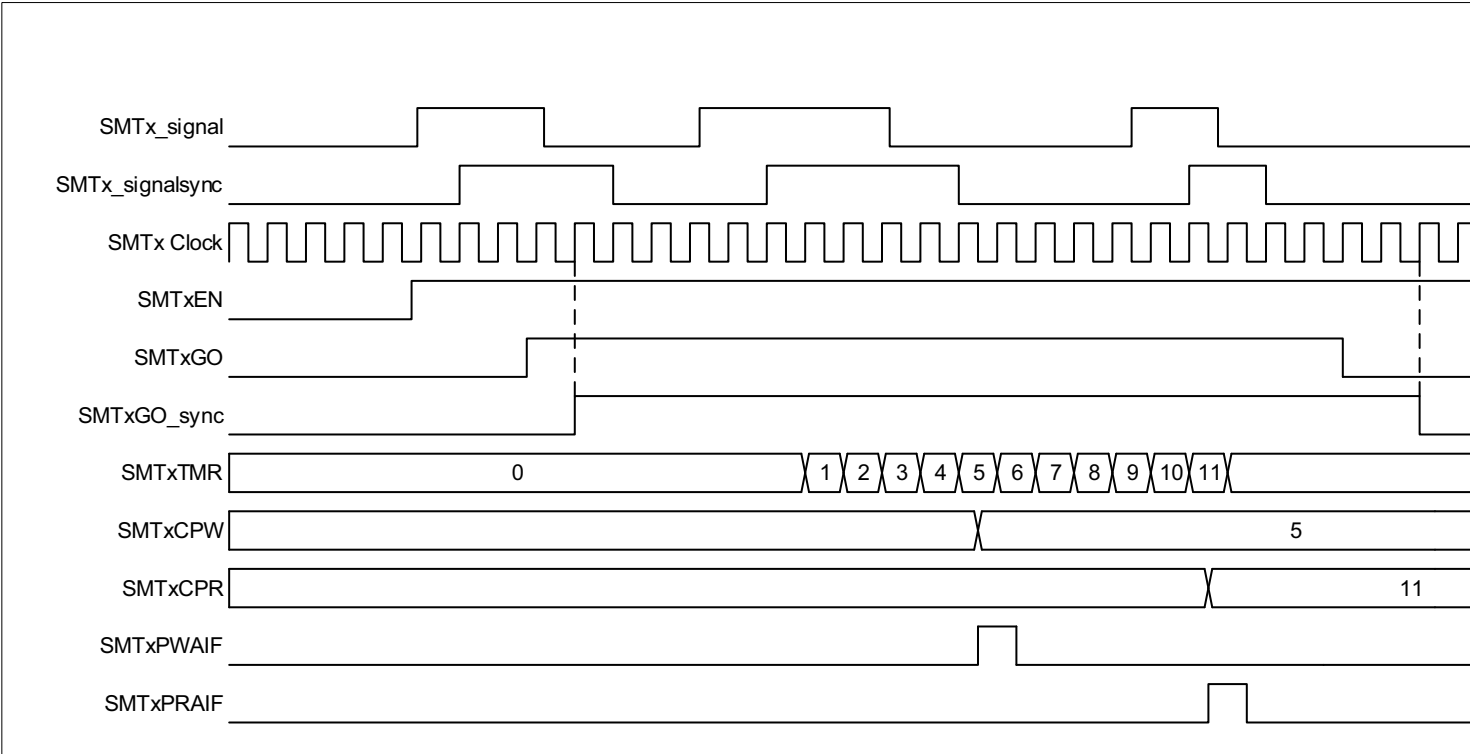

FIGURE 32-7: PERIOD AND DUTY-CYCLE SINGLE ACQUISITION TIMING DIAGRAM



PIC16(L)F18856/76

32.6.4 HIGH AND LOW MEASURE MODE

This mode measures the high and low pulse time of the SMTSIGx relative to the SMT clock. It begins incrementing the SMTxTMR on a rising edge on the SMTSIGx input, then updates the SMTxCPW register with the value and resets the SMTxTMR on a falling edge, starting to increment again. Upon observing another rising edge, it updates the SMTxCPR register with its current value and once again resets the SMTxTMR value and begins incrementing again. See [Figure 32-8](#) and [Figure 32-9](#).

FIGURE 32-8: HIGH AND LOW MEASURE MODE REPEAT ACQUISITION TIMING DIAGRAM

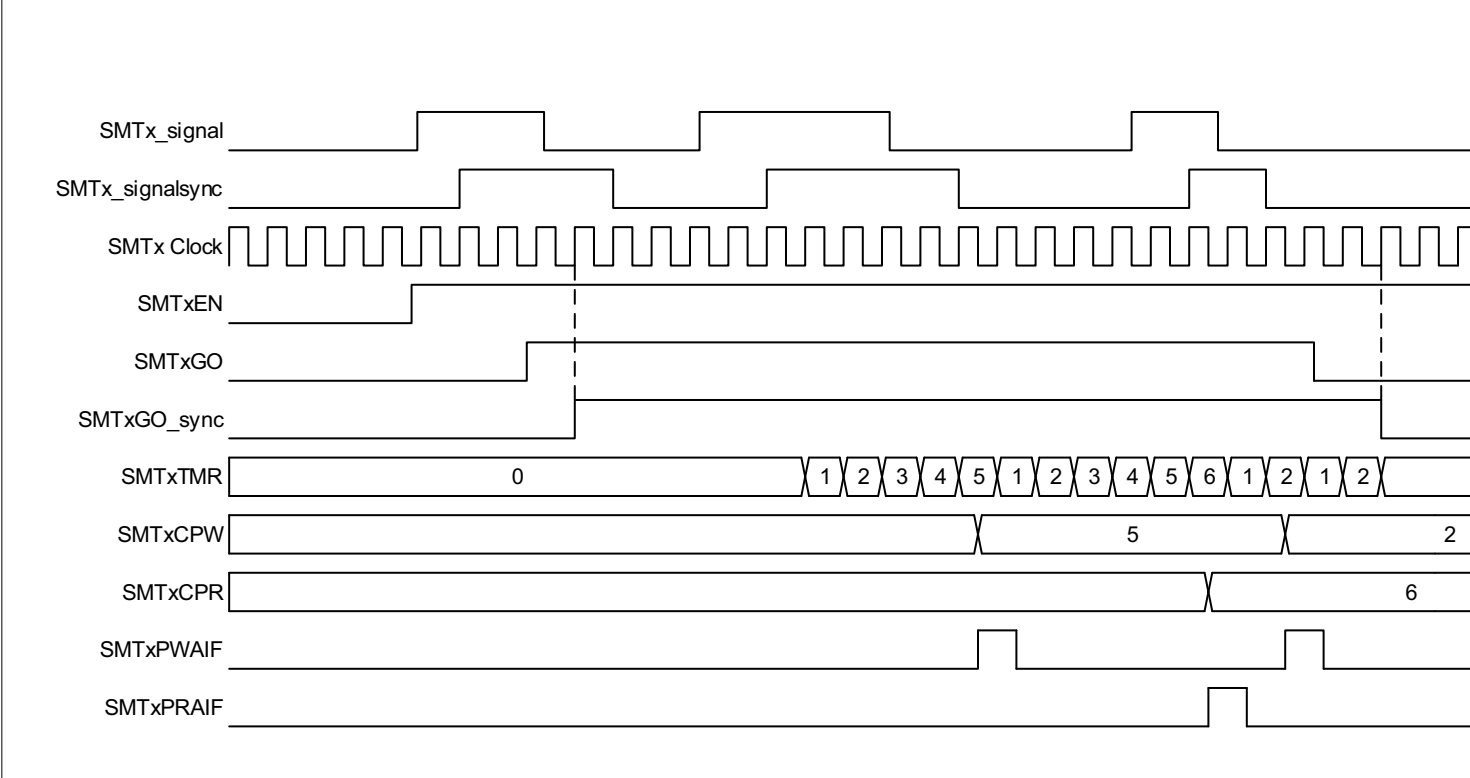
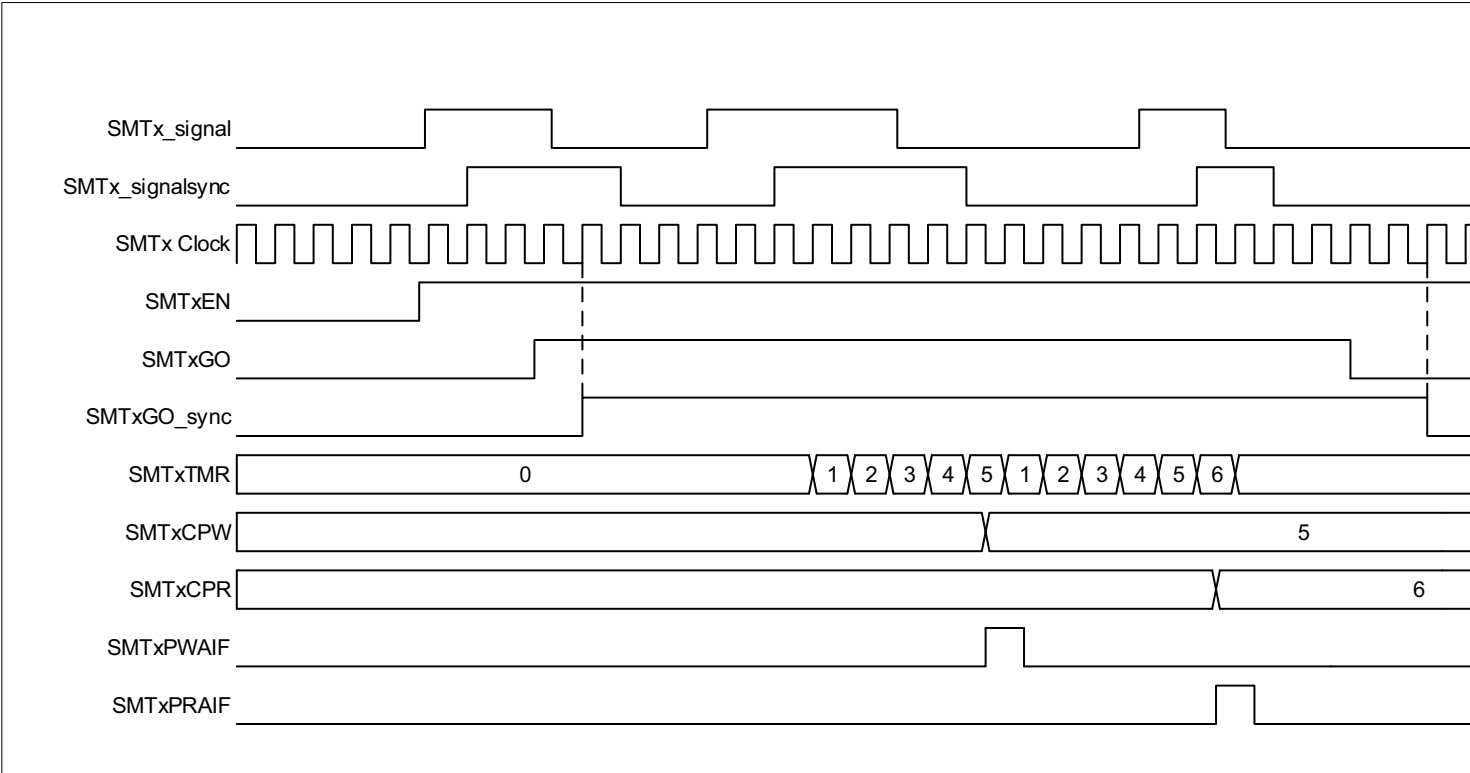

FIGURE 32-9: HIGH AND LOW MEASURE MODE SINGLE ACQUISITION TIMING DIAGRAM



PIC16(L)F18856/76

32.6.5 WINDOWED MEASURE MODE

This mode measures the window duration of the SMTWINx input of the SMT. It begins incrementing the timer on a rising edge of the SMTWINx input and updates the SMTxCPR register with the value of the timer and resets the timer on a second rising edge. See [Figure 32-10](#) and [Figure 32-11](#).

FIGURE 32-10: WINDOWED MEASURE MODE REPEAT ACQUISITION TIMING DIAGRAM

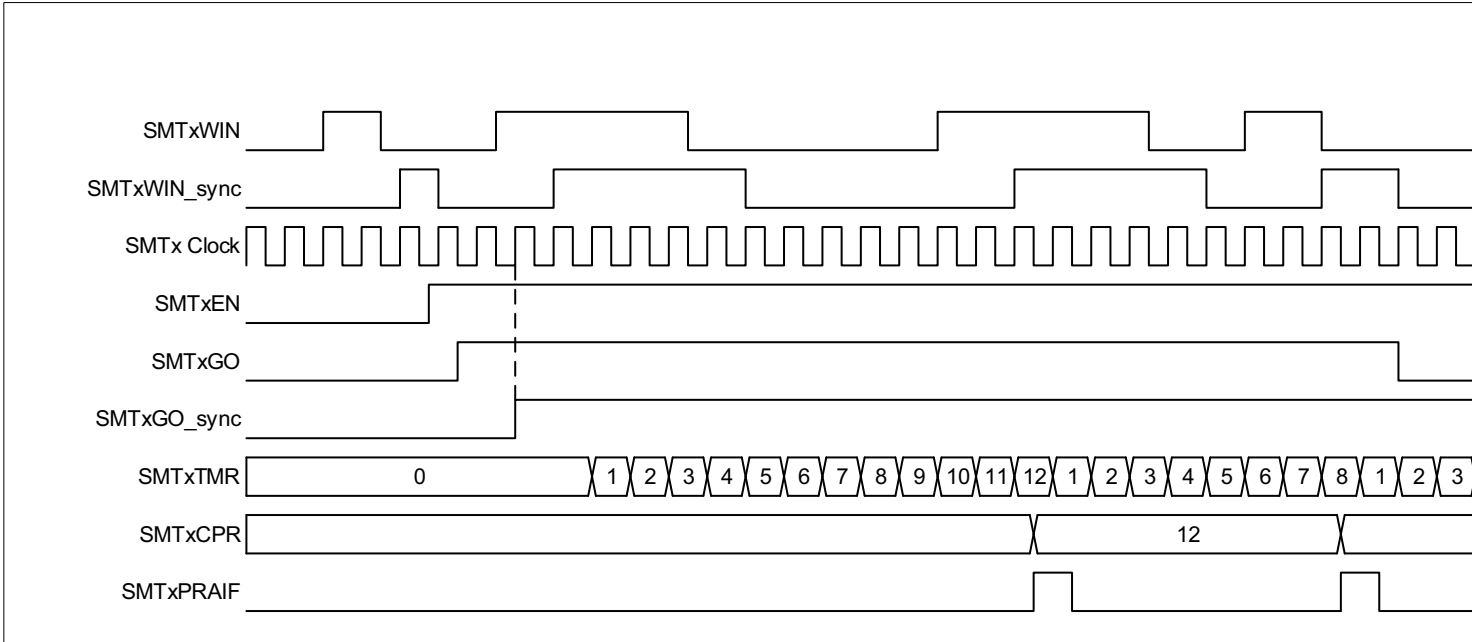
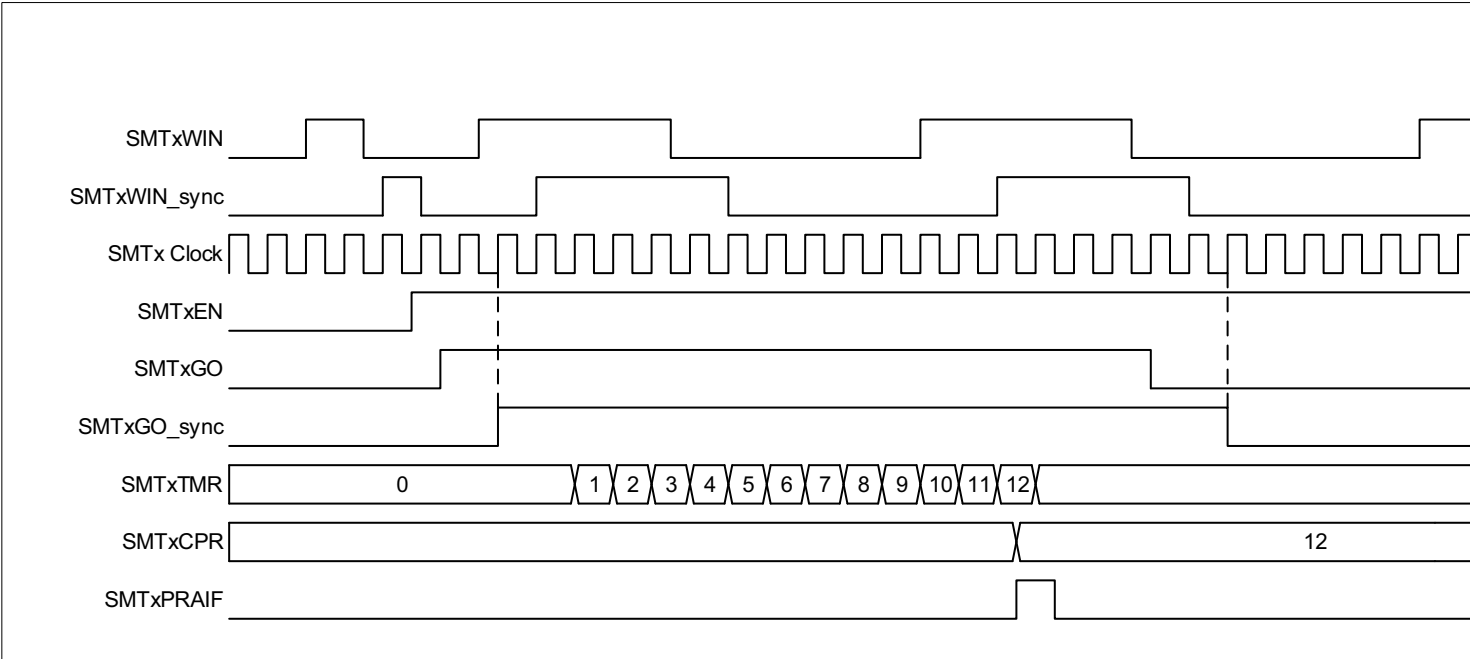

FIGURE 32-11: WINDOWED MEASURE MODE SINGLE ACQUISITION TIMING DIAGRAM



PIC16(L)F18856/76

32.6.6 GATED WINDOW MEASURE MODE

This mode measures the duty cycle of the SMTx_signal input over a known input window. It does so by incrementing the timer on each pulse of the clock signal while the SMTx_signal input is high, updating the SMTxCPR register and resetting the timer on every rising edge of the SMTWINx input after the first. See [Figure 32-12](#) and [Figure 32-13](#).

FIGURE 32-12: GATED WINDOWED MEASURE MODE REPEAT ACQUISITION TIMING DIAGRAM

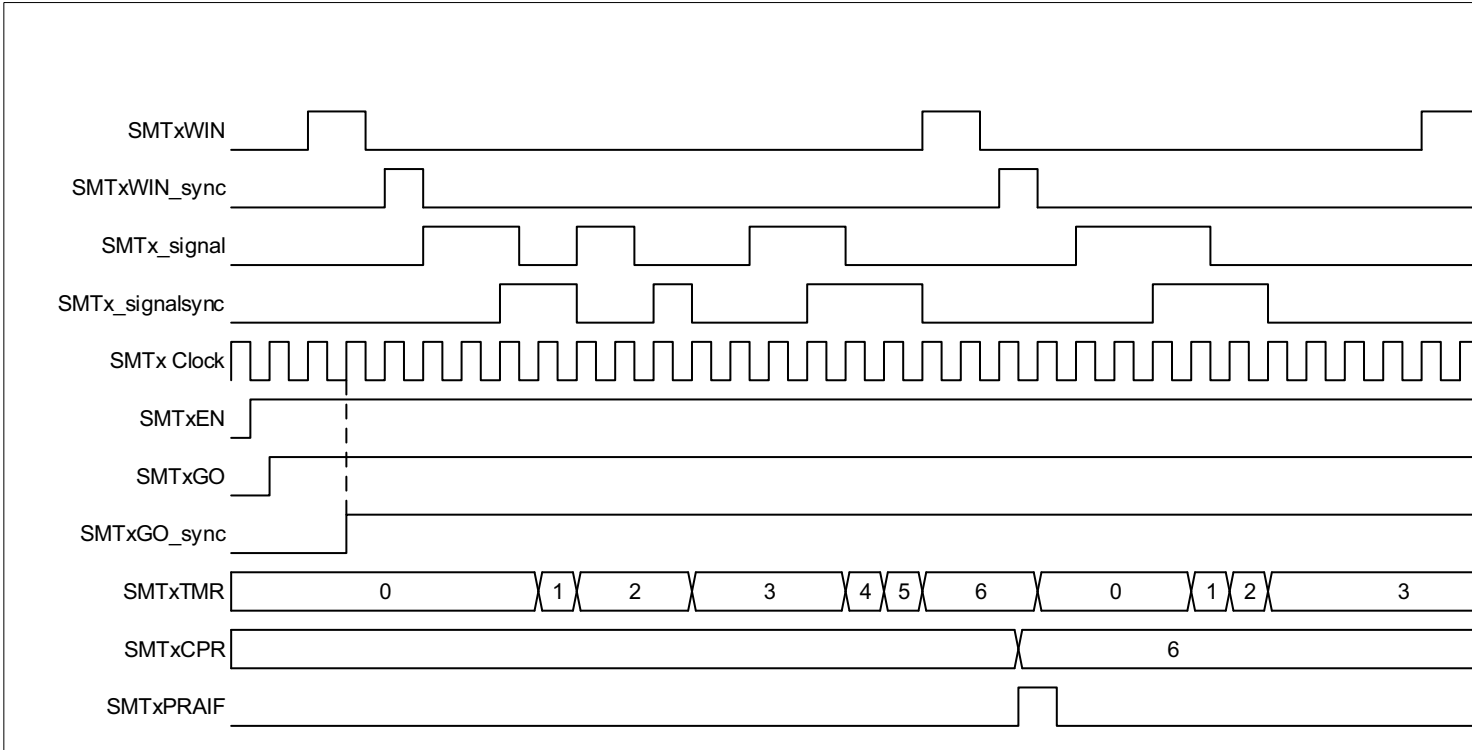
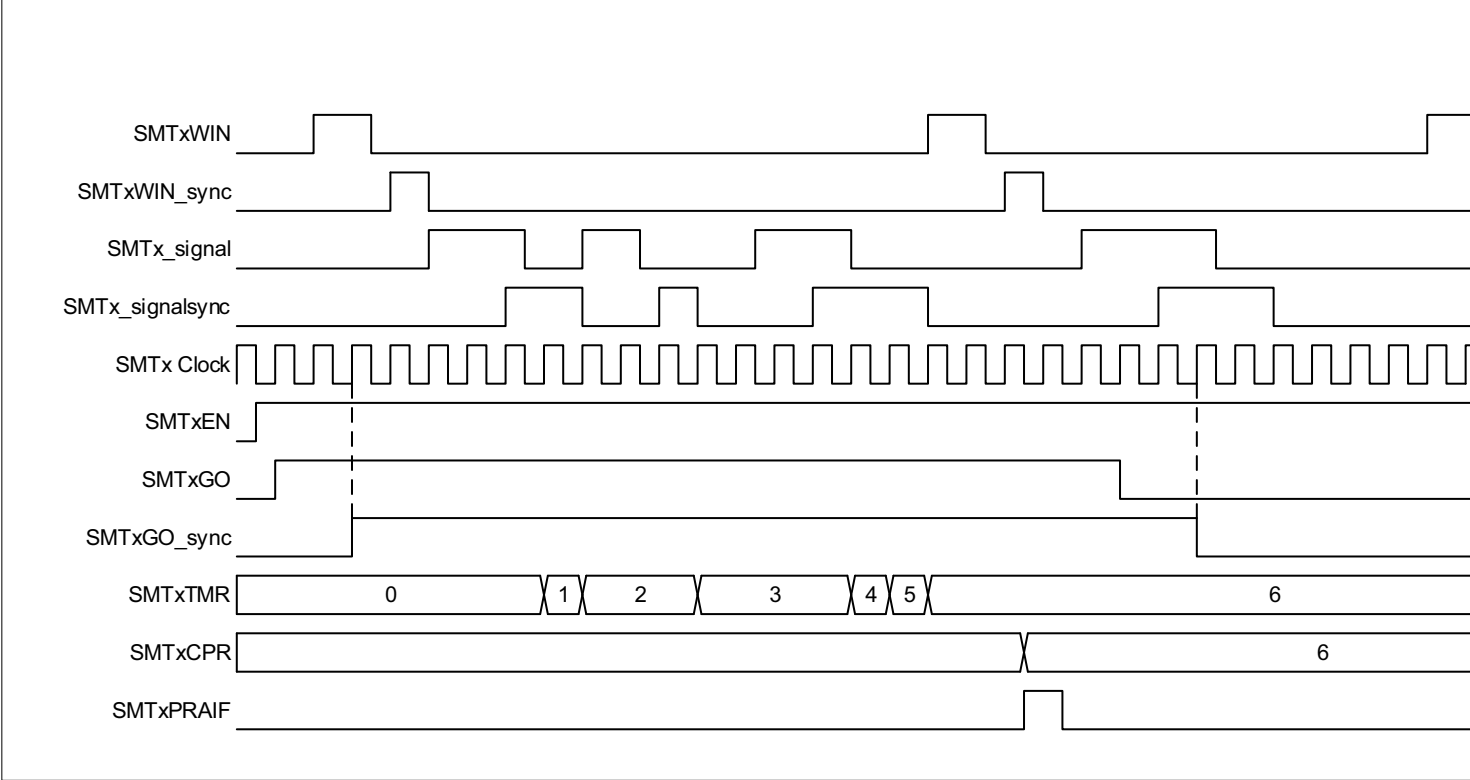

FIGURE 32-13: GATED WINDOWED MEASURE MODE SINGLE ACQUISITION TIMING DIAGRAMS



32.6.7 TIME OF FLIGHT MEASURE MODE

This mode measures the time interval between a rising edge on the SMTWINx input and a rising edge on the SMTx_signal input, beginning to increment the timer upon observing a rising edge on the SMTWINx input, while updating the SMTxCPR register and resetting the timer upon observing a rising edge on the SMTx_signal input. In the event of two SMTWINx rising edges without an SMTx_signal rising edge, it will update the SMTxCPW register with the current value of the timer and reset the timer value. See [Figure 32-14](#) and [Figure 32-15](#).

FIGURE 32-14: TIME OF FLIGHT MODE REPEAT ACQUISITION TIMING DIAGRAM

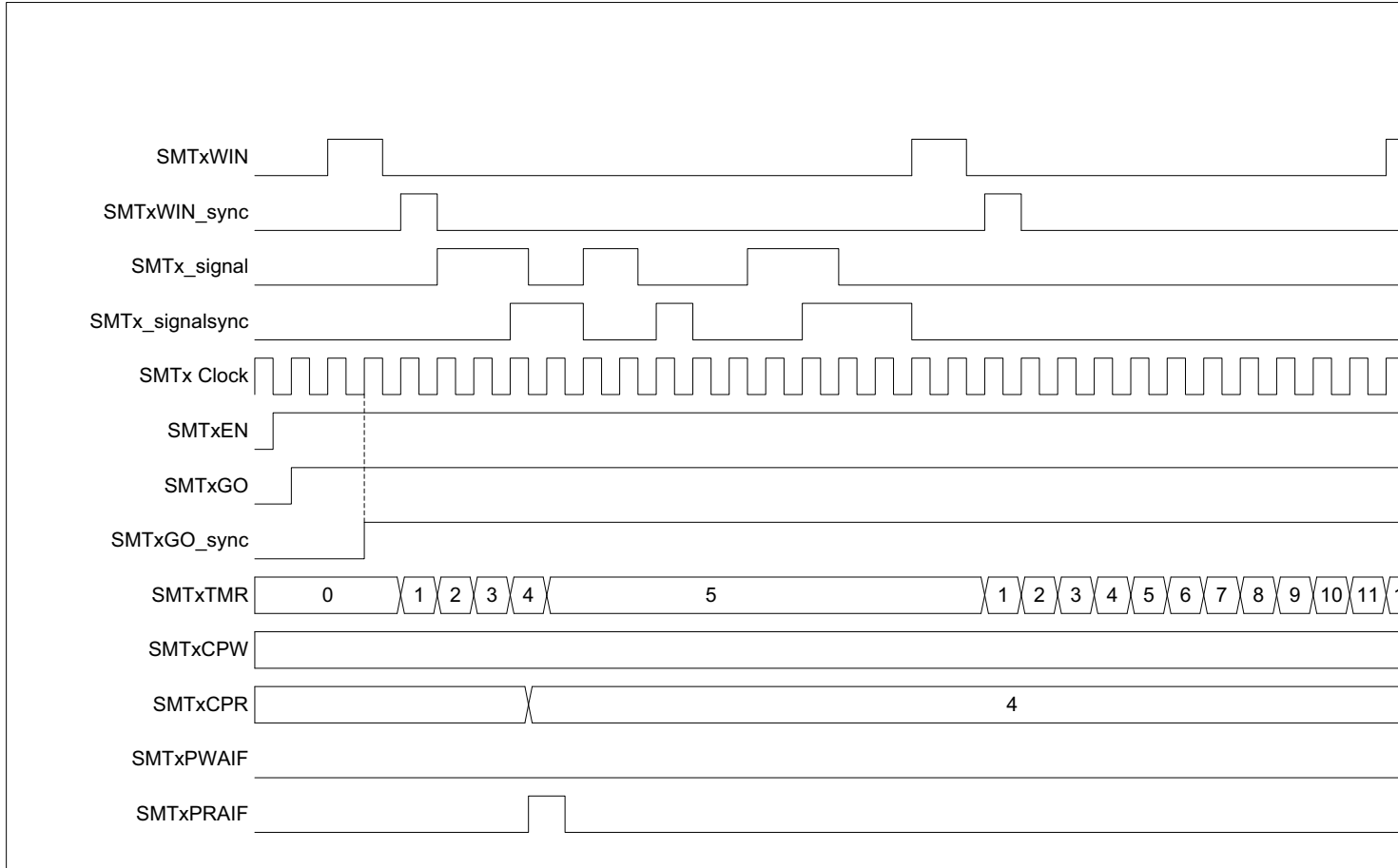
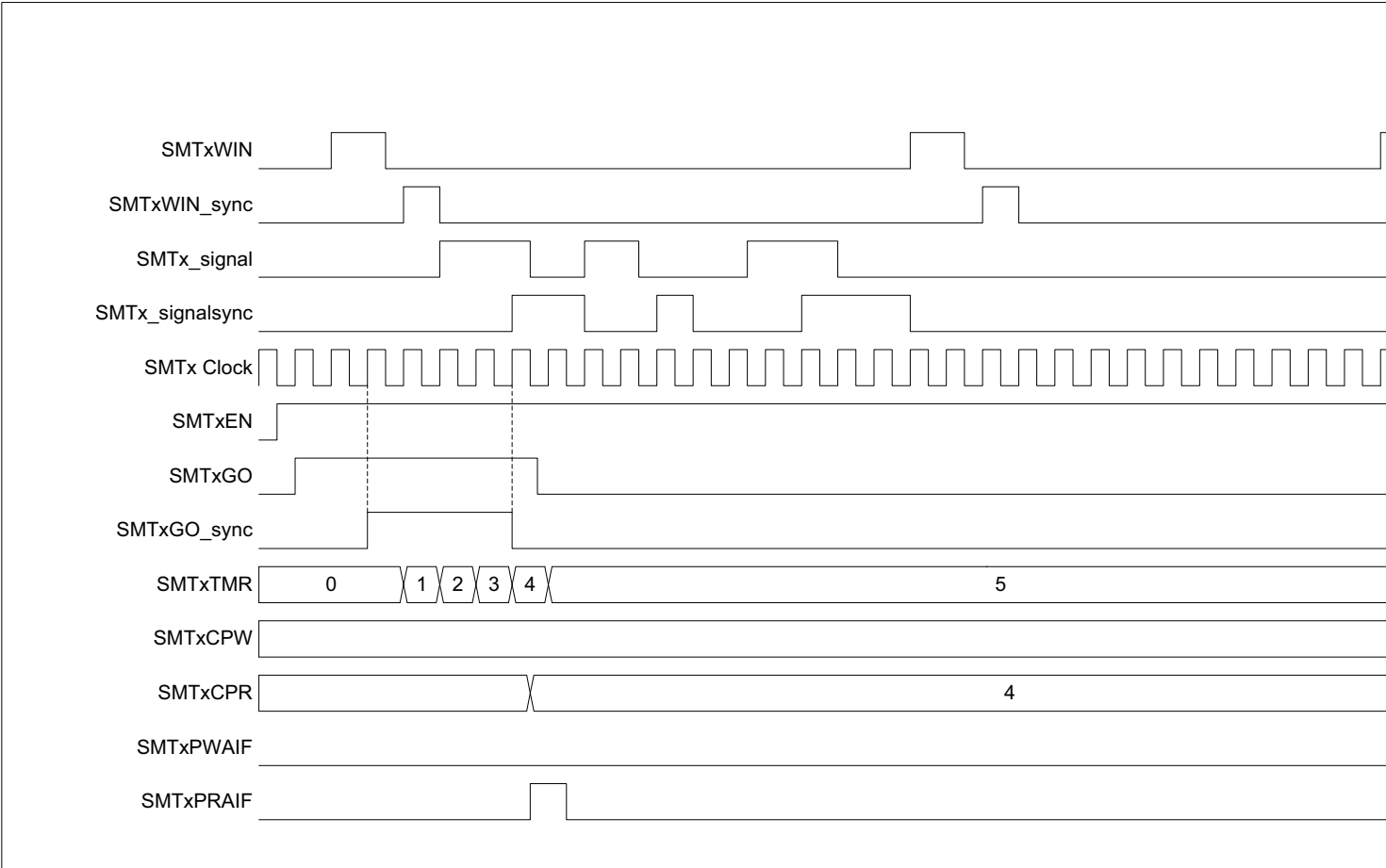

FIGURE 32-15: TIME OF FLIGHT MODE SINGLE ACQUISITION TIMING DIAGRAM



32.6.8 CAPTURE MODE

This mode captures the Timer value based on a rising or falling edge on the SMTWINx input and triggers an interrupt. This mimics the capture feature of a CCP module. The timer begins incrementing upon the SMTxGO bit being set, and updates the value of the SMTxCPR register on each rising edge of SMTWINx, and updates the value of the CPW register on each falling edge of the SMTWINx. The timer is not reset by any hardware conditions in this mode and must be reset by software, if desired. See [Figure 32-16](#) and [Figure 32-17](#).

FIGURE 32-16: CAPTURE MODE REPEAT ACQUISITION TIMING DIAGRAM

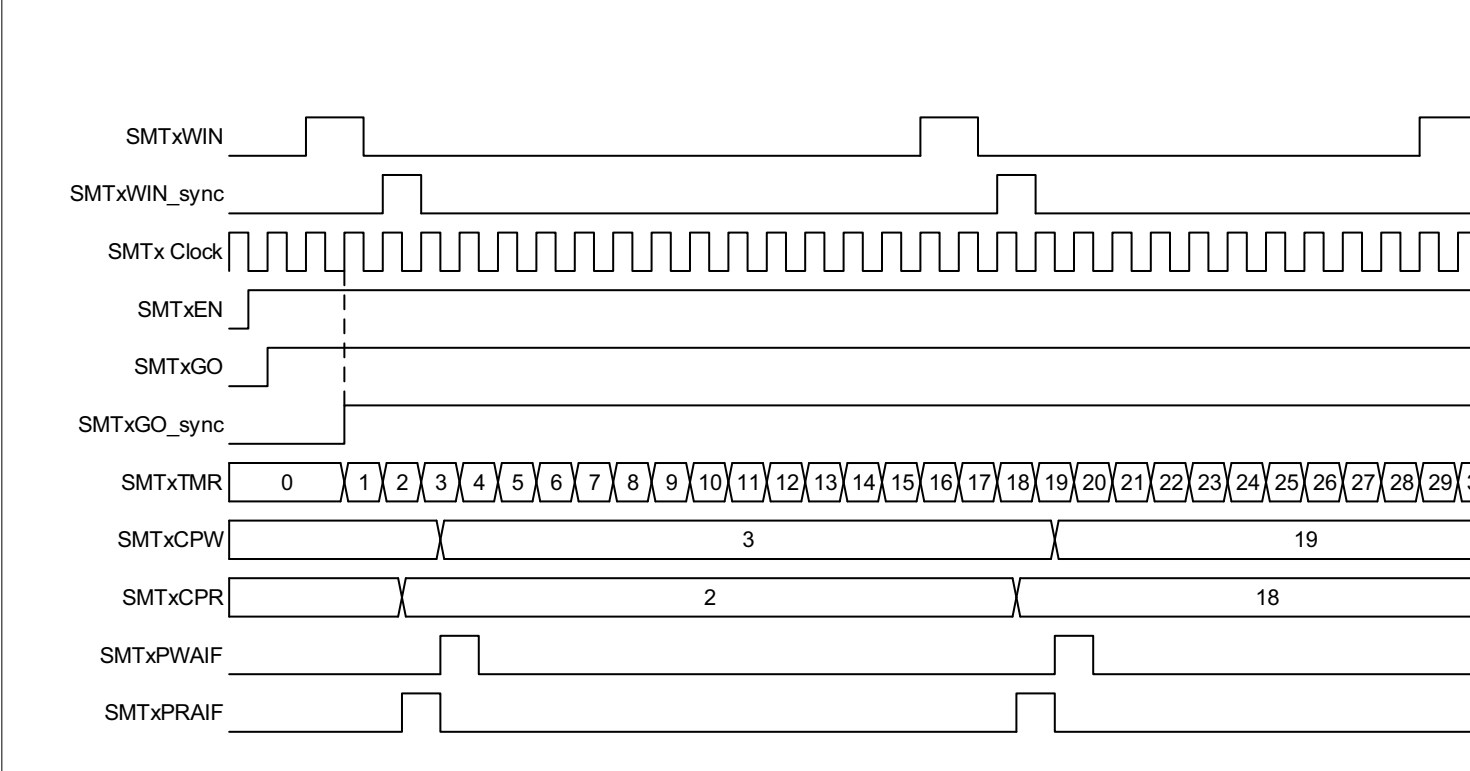
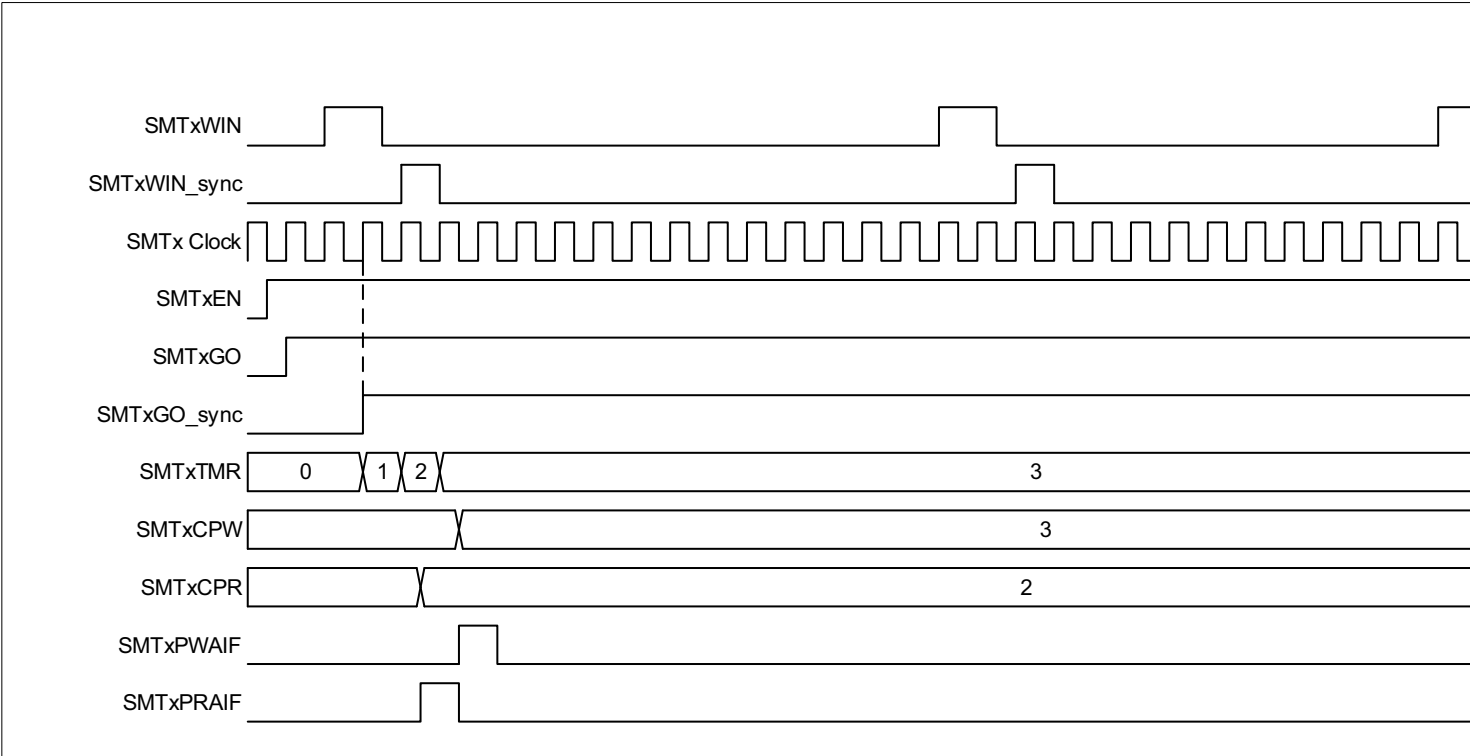

FIGURE 32-17: CAPTURE MODE SINGLE ACQUISITION TIMING DIAGRAM



PIC16(L)F18856/76

32.6.9 COUNTER MODE

This mode increments the timer on each pulse of the SMTx_signal input. This mode is asynchronous to the SMT clock and uses the SMTx_signal as a time source. The SMTxCPW register will be updated with the current SMTxTMR value on the falling edge of the SMTxWIN input. See [Figure 32-18](#).

FIGURE 32-18: COUNTER MODE TIMING DIAGRAM

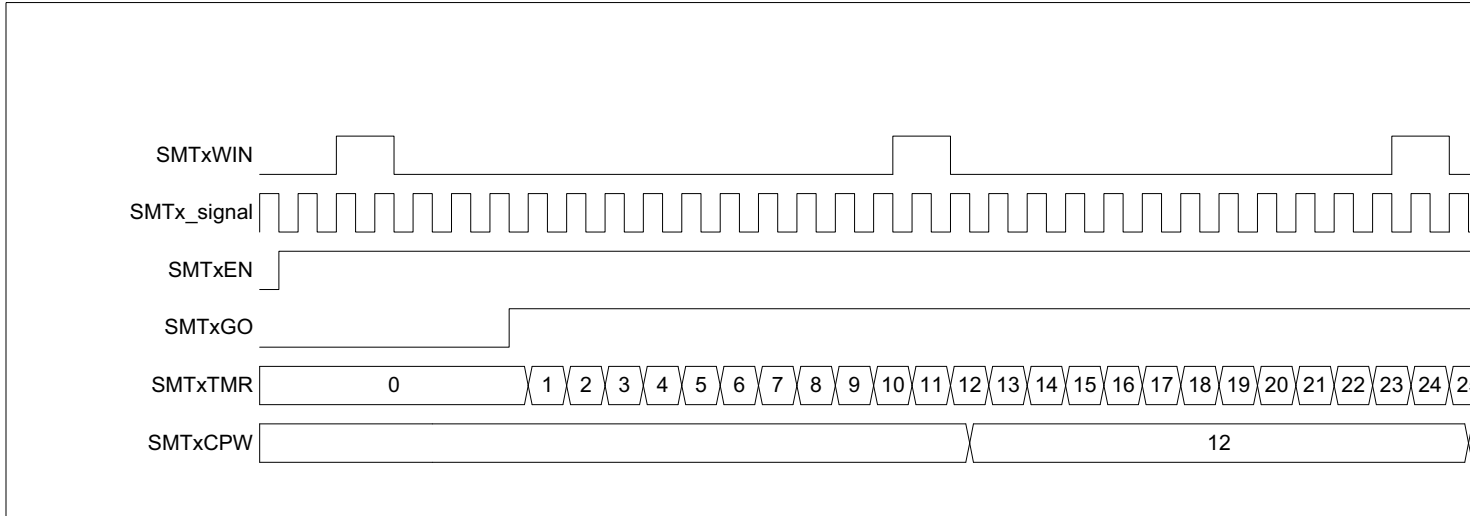

32.6.10 GATED COUNTER MODE

This mode counts pulses on the SMTx_{signal} input, gated by the SMTxWIN input. It begins incrementing the timer upon seeing a rising edge of the SMTxWIN input and updates the SMTxCPW register upon a falling edge on the SMTxWIN input. See [Figure 32-19](#) and [Figure 32-20](#).

FIGURE 32-19: GATED COUNTER MODE REPEAT ACQUISITION TIMING DIAGRAM

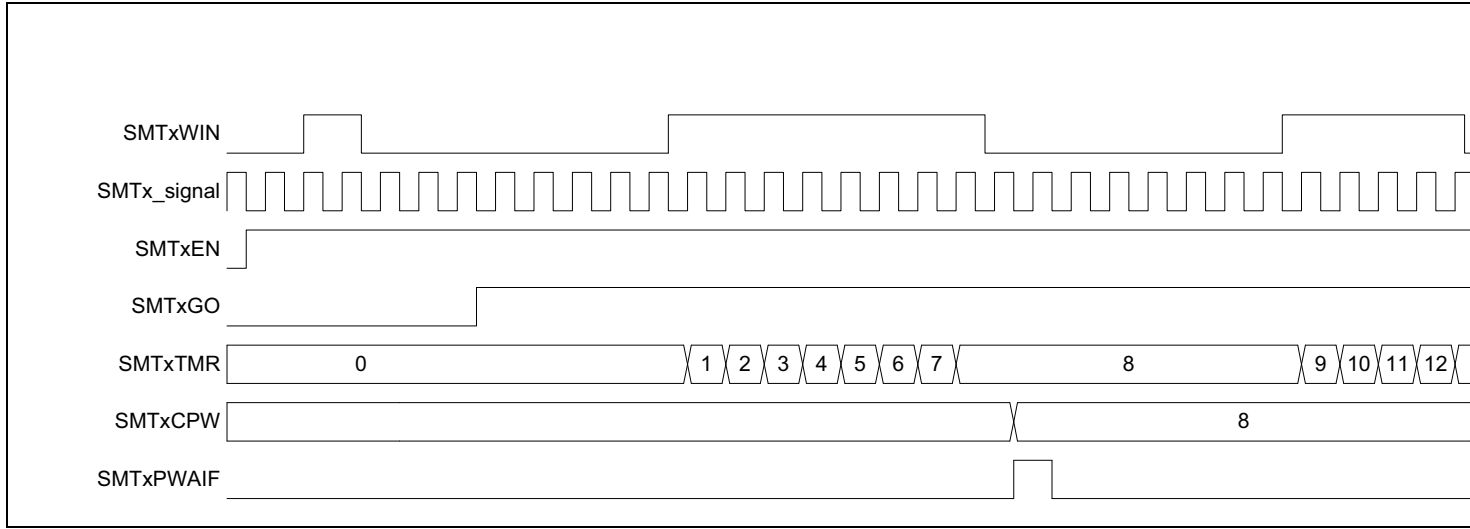
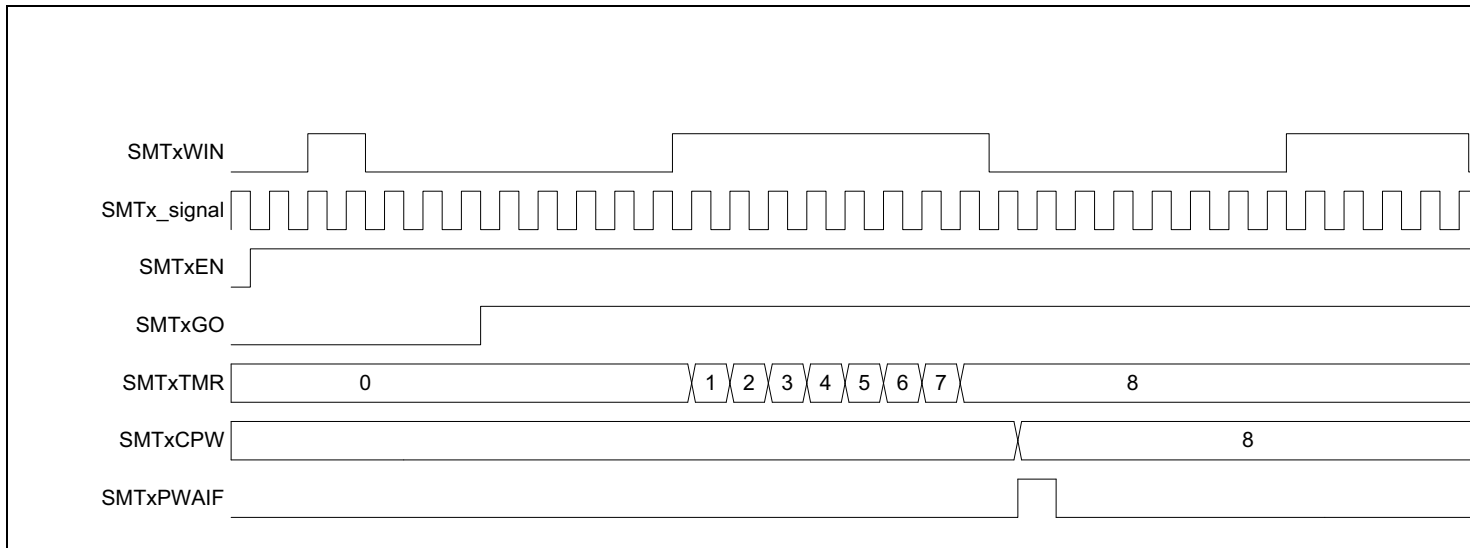

FIGURE 32-20: GATED COUNTER MODE SINGLE ACQUISITION TIMING DIAGRAM



PIC16(L)F18856/76

32.6.11 WINDOWED COUNTER MODE

This mode counts pulses on the SMTx_{signal} input, within a window dictated by the SMTxWIN input. It begins counting upon seeing a rising edge of the SMTxWIN input, updates the SMTxCPW register on a falling edge of the SMTxWIN input, and updates the SMTxCPR register on each rising edge of the SMTxWIN input beyond the first. See [Figure 32-21](#) and [Figure 32-22](#).

FIGURE 32-21: WINDOWED COUNTER MODE REPEAT ACQUISITION TIMING DIAGRAM

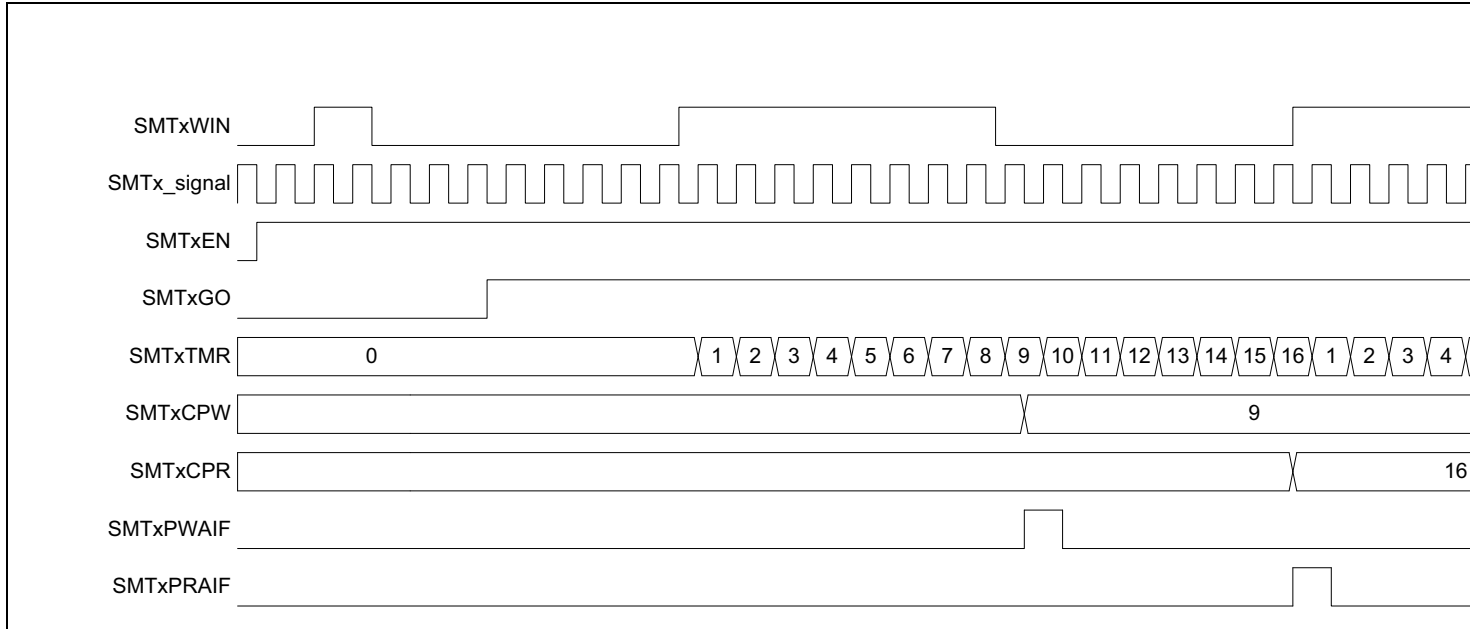
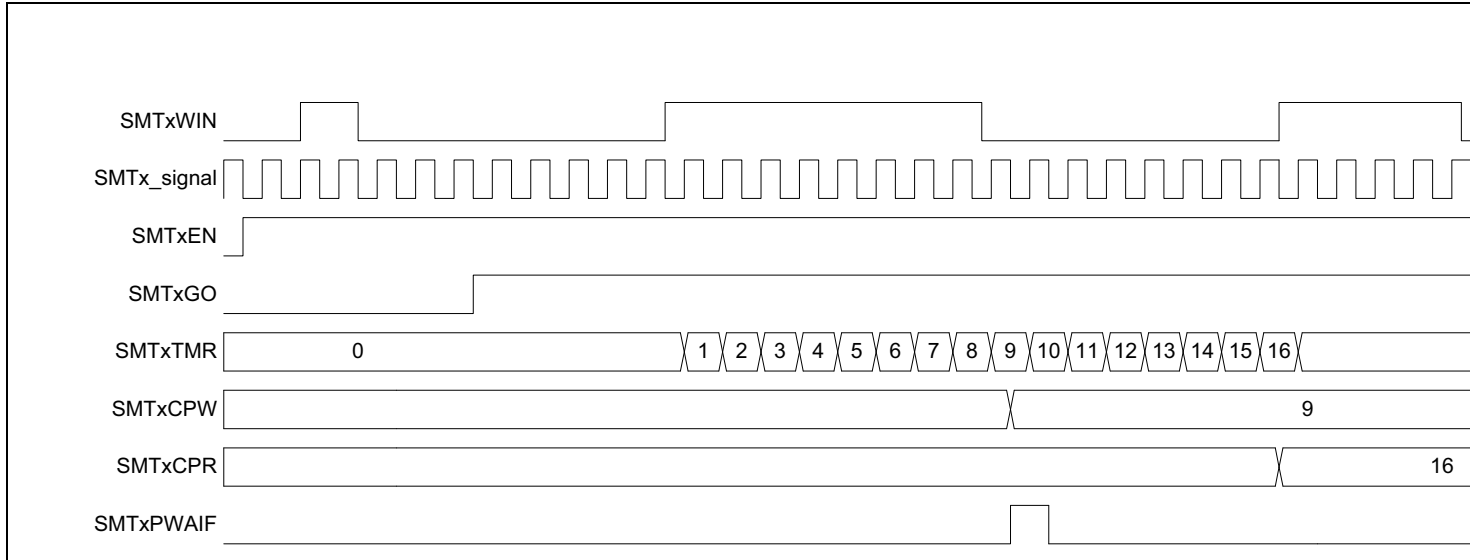

FIGURE 32-22: WINDOWED COUNTER MODE SINGLE ACQUISITION TIMING DIAGRAM



PIC16(L)F18856/76

32.7 Interrupts

The SMT can trigger an interrupt under three different conditions:

- PW Acquisition Complete
- PR Acquisition Complete
- Counter Period Match

The interrupts are controlled by the PIR and PIE registers of the device.

32.7.1 PW AND PR ACQUISITION INTERRUPTS

The SMT can trigger interrupts whenever it updates the SMTxCPW and SMTxCPR registers, the circumstances for which are dependent on the SMT mode, and are discussed in each mode's specific section. The SMTxCPW interrupt is controlled by SMTxPWAIF and SMTxPWAIE bits in registers PIR8 and PIE8, respectively. The SMTxCPR interrupt is controlled by the SMTxPRAIF and SMTxPRAIE bits, also located in registers PIR8 and PIE8, respectively.

In synchronous SMT modes, the interrupt trigger is synchronized to the SMTxCLK. In Asynchronous modes, the interrupt trigger is asynchronous. In either mode, once triggered, the interrupt will be synchronized to the CPU clock.

32.7.2 COUNTER PERIOD MATCH INTERRUPT

As described in [Section 32.1.2 “Period Match interrupt”](#), the SMT will also interrupt upon SMTxTMR, matching SMTxPR with its period match limit functionality described in [Section 32.3 “Halt Operation”](#). The period match interrupt is controlled by SMTxIF and SMTxIE, located in registers PIR8 and PIE8, respectively.

PIC16(L)F18856/76

32.8 Register Definitions: SMT Control

Long bit name prefixes for the Signal Measurement Timer peripherals are shown in [Section 1.1 “Register and Bit naming conventions”](#).

TABLE 32-2: LONG BIT NAMES PREFIXES FOR SMT PERIPHERALS

Peripheral	Bit Name Prefix
SMT1	SMT1
SMT2	SMT2

REGISTER 32-1: SMTxCON0: SMT CONTROL REGISTER 0

R/W-0/0	U-0	R/W-0/0	R/W-0/0	R/W-0/0	R/W-0/0	R/W-0/0	R/W-0/0
EN ⁽¹⁾	—	STP	WPOL	SPOL	CPOL	SMTxPS<1:0>	
bit 7							bit 0

Legend:

R = Readable bit	W = Writable bit	U = Unimplemented bit, read as '0'
u = Bit is unchanged	x = Bit is unknown	-n/n = Value at POR and BOR/Value at all other Resets
'1' = Bit is set	'0' = Bit is cleared	

- bit 7 **EN:** SMT Enable bit⁽¹⁾
 1 = SMT is enabled
 0 = SMT is disabled; internal states are reset, clock requests are disabled
- bit 6 **Unimplemented:** Read as '0'
- bit 5 **STP:** SMT Counter Halt Enable bit
 When SMTxTMR = SMTxPR:
 1 = Counter remains SMTxPR; period match interrupt occurs when clocked
 0 = Counter resets to 24'h000000; period match interrupt occurs when clocked
- bit 4 **WPOL:** SMTxWIN Input Polarity Control bit
 1 = SMTxWIN signal is active-low/falling edge enabled
 0 = SMTxWIN signal is active-high/rising edge enabled
- bit 3 **SPOL:** SMTxSIG Input Polarity Control bit
 1 = SMTx_signal is active-low/falling edge enabled
 0 = SMTx_signal is active-high/rising edge enabled
- bit 2 **CPOL:** SMT Clock Input Polarity Control bit
 1 = SMTxTMR increments on the falling edge of the selected clock signal
 0 = SMTxTMR increments on the rising edge of the selected clock signal
- bit 1-0 **SMTxPS<1:0>:** SMT Prescale Select bits
 11 = Prescaler = 1:8
 10 = Prescaler = 1:4
 01 = Prescaler = 1:2
 00 = Prescaler = 1:1

Note 1: Setting EN to '0' does not affect the register contents.

PIC16(L)F18856/76

REGISTER 32-2: SMTxCON1: SMT CONTROL REGISTER 1

R/W/HC-0/0	R/W-0/0	U-0	U-0	R/W-0/0	R/W-0/0	R/W-0/0	R/W-0/0
SMTxGO	REPEAT	—	—	MODE<3:0>			
bit 7							bit 0

Legend:

HC = Bit is cleared by hardware

HS = Bit is set by hardware

R = Readable bit

W = Writable bit

U = Unimplemented bit, read as '0'

u = Bit is unchanged

x = Bit is unknown

-n/n = Value at POR and BOR/Value at all other Resets

'1' = Bit is set

'0' = Bit is cleared

q = Value depends on condition

- bit 7 **SMTxGO:** SMT GO Data Acquisition bit
 1 = Incrementing, acquiring data is enabled
 0 = Incrementing, acquiring data is disabled
- bit 6 **REPEAT:** SMT Repeat Acquisition Enable bit
 1 = Repeat Data Acquisition mode is enabled
 0 = Single Acquisition mode is enabled
- bit 5-4 **Unimplemented:** Read as '0'
- bit 3-0 **MODE<3:0>** SMT Operation Mode Select bits
 1111 = Reserved
 •
 •
 •
 1011 = Reserved
 1010 = Windowed counter
 1001 = Gated counter
 1000 = Counter
 0111 = Capture
 0110 = Time of flight
 0101 = Gated windowed measure
 0100 = Windowed measure
 0011 = High and low time measurement
 0010 = Period and Duty-Cycle Acquisition
 0001 = Gated Timer
 0000 = Timer

PIC16(L)F18856/76

REGISTER 32-3: SMTxSTAT: SMT STATUS REGISTER

R/W/HC-0/0	R/W/HC-0/0	R/W/HC-0/0	U-0	U-0	R-0/0	R-0/0	R-0/0
CPRUP	CPWUP	RST	—	—	TS	WS	AS
bit 7							bit 0

Legend:

HC = Bit is cleared by hardware

HS = Bit is set by hardware

R = Readable bit

W = Writable bit

U = Unimplemented bit, read as '0'

u = Bit is unchanged

x = Bit is unknown

-n/n = Value at POR and BOR/Value at all other Resets

'1' = Bit is set

'0' = Bit is cleared

q = Value depends on condition

- bit 7 **CPRUP:** SMT Manual Period Buffer Update bit
 1 = Request update to SMTxPRx registers
 0 = SMTxPRx registers update is complete
- bit 6 **CPWUP:** SMT Manual Pulse Width Buffer Update bit
 1 = Request update to SMTxCPW registers
 0 = SMTxCPW registers update is complete
- bit 5 **RST:** SMT Manual Timer Reset bit
 1 = Request Reset to SMTxTMR registers
 0 = SMTxTMR registers update is complete
- bit 4-3 **Unimplemented:** Read as '0'
- bit 2 **TS:** SMT GO Value Status bit
 1 = SMT timer is incrementing
 0 = SMT timer is not incrementing
- bit 1 **WS:** SMTxWIN Value Status bit
 1 = SMT window is open
 0 = SMT window is closed
- bit 0 **AS:** SMT_signal Value Status bit
 1 = SMT acquisition is in progress
 0 = SMT acquisition is not in progress

PIC16(L)F18856/76

REGISTER 32-4: SMTxCLK: SMT CLOCK SELECTION REGISTER

U-0	U-0	U-0	U-0	U-0	R/W-0/0	R/W-0/0	R/W-0/0
—	—	—	—	—	CSEL<2:0>		
bit 7					bit 0		

Legend:

R = Readable bit

W = Writable bit

U = Unimplemented bit, read as '0'

u = Bit is unchanged

x = Bit is unknown

-n/n = Value at POR and BOR/Value at all other Resets

'1' = Bit is set

'0' = Bit is cleared

q = Value depends on condition

bit 7-3

Unimplemented: Read as '0'

bit 2-0

CSEL<2:0>: SMT Clock Selection bits

111 = Reference Clock Output

110 = SOSC

101 = MFINTOSC/16

100 = MFINTOSC

011 = LFINTOSC

010 = HFINTOSC 16 MHz

001 = Fosc

000 = Fosc/4

PIC16(L)F18856/76

REGISTER 32-5: SMTxWIN: SMT1 WINDOW INPUT SELECT REGISTER

U-0	U-0	U-0	R/W-0/0	R/W-0/0	R/W-0/0	R/W-0/0	R/W-0/0
—	—	—	WSEL<4:0>				
bit 7							bit 0

Legend:

R = Readable bit	W = Writable bit	U = Unimplemented bit, read as '0'
u = Bit is unchanged	x = Bit is unknown	-n/n = Value at POR and BOR/Value at all other Resets
'1' = Bit is set	'0' = Bit is cleared	q = Value depends on condition

bit 7-5 **Unimplemented:** Read as '0'

bit 4-0 **WSEL<4:0>:** SMTx Window Selection bits

- 11111 = Reserved
-
-
-
- 11000 = Reserved
- 10111 = LC4_out
- 10110 = LC3_out
- 10101 = LC2_out
- 10100 = LC1_out
- 10011 = ZCD1_output
- 10010 = C2OUT_sync
- 10001 = C1OUT_sync
- 10000 = PWM7_out
- 01111 = PWM6_out
- 01110 = CCP5_out
- 01101 = CCP4_out
- 01100 = CCP3_out
- 01011 = CCP2_out
- 01010 = CCP1_out
- 01001 = SMT2_match⁽¹⁾
- 01000 = SMT1_match⁽¹⁾
- 00111 = TMR6_postscaled
- 00110 = TMR4_postscaled
- 00101 = TMR2_postscaled
- 00100 = TMR0_overflow
- 00011 = SOSC
- 00010 = MFINTOSC/16
- 00001 = LFINTOSC
- 00000 = SMTxWINPPS

Note 1: The SMT_match corresponding to the SMT selected becomes reserved.

PIC16(L)F18856/76

REGISTER 32-6: SMTxSIG: SMT1 SIGNAL INPUT SELECT REGISTER

U-0	U-0	U-0	R/W-0/0	R/W-0/0	R/W-0/0	R/W-0/0	R/W-0/0
—	—	—	SSEL<4:0>				
bit 7							bit 0

Legend:

R = Readable bit	W = Writable bit	U = Unimplemented bit, read as '0'
u = Bit is unchanged	x = Bit is unknown	-n/n = Value at POR and BOR/Value at all other Resets
'1' = Bit is set	'0' = Bit is cleared	q = Value depends on condition

bit 7-5 **Unimplemented:** Read as '0'

bit 4-0 **SSEL<4:0>:** SMTx Signal Selection bits

```

11111 = Reserved
.
.
.
11000 = LC4_out
10111 = LC3_out
10110 = LC2_out
10101 = LC1_out
10100 = ZCD1_output
10011 = C2OUT_sync
10010 = C1OUT_sync
10001 = NCO output
10000 = PWM7_out
01111 = PWM6_out
01110 = CCP5_out
01101 = CCP4_out
01100 = CCP3_out
01011 = CCP2_out
01010 = CCP1_out
01001 = SMT2_match(1)
01000 = SMT1_match(1)
00111 = TMR6_postscaled
00110 = TMR5_postscaled
00101 = TMR4_postscaled
00100 = TMR3_postscaled
00011 = TMR2_postscaled
00010 = TMR1_postscaled
00001 = TMR0_overflow
00000 = SMTxSIGPPS

```

Note 1: The SMT_match corresponding to the SMT selected becomes reserved.

PIC16(L)F18856/76

REGISTER 32-7: SMTxTMRL: SMT TIMER REGISTER – LOW BYTE

R/W-0/0	R/W-0/0	R/W-0/0	R/W-0/0	R/W-0/0	R/W-0/0	R/W-0/0	R/W-0/0
SMTxTMR<7:0>							
bit 7							bit 0

Legend:

R = Readable bit	W = Writable bit	U = Unimplemented bit, read as '0'
u = Bit is unchanged	x = Bit is unknown	-n/n = Value at POR and BOR/Value at all other Resets
'1' = Bit is set	'0' = Bit is cleared	

bit 7-0 **SMTxTMR<7:0>**: Significant bits of the SMT Counter – Low Byte

REGISTER 32-8: SMTxTMRH: SMT TIMER REGISTER – HIGH BYTE

R/W-0/0	R/W-0/0	R/W-0/0	R/W-0/0	R/W-0/0	R/W-0/0	R/W-0/0	R/W-0/0
SMTxTMR<15:8>							
bit 7							bit 0

Legend:

R = Readable bit	W = Writable bit	U = Unimplemented bit, read as '0'
u = Bit is unchanged	x = Bit is unknown	-n/n = Value at POR and BOR/Value at all other Resets
'1' = Bit is set	'0' = Bit is cleared	

bit 7-0 **SMTxTMR<15:8>**: Significant bits of the SMT Counter – High Byte

REGISTER 32-9: SMTxTMRU: SMT TIMER REGISTER – UPPER BYTE

R/W-0/0	R/W-0/0	R/W-0/0	R/W-0/0	R/W-0/0	R/W-0/0	R/W-0/0	R/W-0/0
SMTxTMR<23:16>							
bit 7							bit 0

Legend:

R = Readable bit	W = Writable bit	U = Unimplemented bit, read as '0'
u = Bit is unchanged	x = Bit is unknown	-n/n = Value at POR and BOR/Value at all other Resets
'1' = Bit is set	'0' = Bit is cleared	

bit 7-0 **SMTxTMR<23:16>**: Significant bits of the SMT Counter – Upper Byte

PIC16(L)F18856/76

REGISTER 32-10: SMTxCPRL: SMT CAPTURED PERIOD REGISTER – LOW BYTE

R-x/x	R-x/x	R-x/x	R-x/x	R-x/x	R-x/x	R-x/x	R-x/x
SMTxCPR<7:0>							
bit 7				bit 0			

Legend:

R = Readable bit	W = Writable bit	U = Unimplemented bit, read as '0'
u = Bit is unchanged	x = Bit is unknown	-n/n = Value at POR and BOR/Value at all other Resets
'1' = Bit is set	'0' = Bit is cleared	

bit 7-0 **SMTxCPR<7:0>**: Significant bits of the SMT Period Latch – Low Byte

REGISTER 32-11: SMTxCPRH: SMT CAPTURED PERIOD REGISTER – HIGH BYTE

R-x/x	R-x/x	R-x/x	R-x/x	R-x/x	R-x/x	R-x/x	R-x/x
SMTxCPR<15:8>							
bit 7				bit 0			

Legend:

R = Readable bit	W = Writable bit	U = Unimplemented bit, read as '0'
u = Bit is unchanged	x = Bit is unknown	-n/n = Value at POR and BOR/Value at all other Resets
'1' = Bit is set	'0' = Bit is cleared	

bit 7-0 **SMTxCPR<15:8>**: Significant bits of the SMT Period Latch – High Byte

REGISTER 32-12: SMTxCPRU: SMT CAPTURED PERIOD REGISTER – UPPER BYTE

R-x/x	R-x/x	R-x/x	R-x/x	R-x/x	R-x/x	R-x/x	R-x/x
SMTxCPR<23:16>							
bit 7				bit 0			

Legend:

R = Readable bit	W = Writable bit	U = Unimplemented bit, read as '0'
u = Bit is unchanged	x = Bit is unknown	-n/n = Value at POR and BOR/Value at all other Resets
'1' = Bit is set	'0' = Bit is cleared	

bit 7-0 **SMTxCPR<23:16>**: Significant bits of the SMT Period Latch – Upper Byte

PIC16(L)F18856/76

REGISTER 32-13: SMTxCPWL: SMT CAPTURED PULSE WIDTH REGISTER – LOW BYTE

R-x/x	R-x/x	R-x/x	R-x/x	R-x/x	R-x/x	R-x/x	R-x/x
SMTxCPW<7:0>							
bit 7							bit 0

Legend:

R = Readable bit

W = Writable bit

U = Unimplemented bit, read as '0'

u = Bit is unchanged

x = Bit is unknown

-n/n = Value at POR and BOR/Value at all other Resets

'1' = Bit is set

'0' = Bit is cleared

bit 7-0 **SMTxCPW<7:0>**: Significant bits of the SMT PW Latch – Low Byte

REGISTER 32-14: SMTxCPWH: SMT CAPTURED PULSE WIDTH REGISTER – HIGH BYTE

R-x/x	R-x/x	R-x/x	R-x/x	R-x/x	R-x/x	R-x/x	R-x/x
SMTxCPW<15:8>							
bit 7							bit 0

Legend:

R = Readable bit

W = Writable bit

U = Unimplemented bit, read as '0'

u = Bit is unchanged

x = Bit is unknown

-n/n = Value at POR and BOR/Value at all other Resets

'1' = Bit is set

'0' = Bit is cleared

bit 7-0 **SMTxCPW<15:8>**: Significant bits of the SMT PW Latch – High Byte

REGISTER 32-15: SMTxCPWU: SMT CAPTURED PULSE WIDTH REGISTER – UPPER BYTE

R-x/x	R-x/x	R-x/x	R-x/x	R-x/x	R-x/x	R-x/x	R-x/x
SMTxCPW<23:16>							
bit 7							bit 0

Legend:

R = Readable bit

W = Writable bit

U = Unimplemented bit, read as '0'

u = Bit is unchanged

x = Bit is unknown

-n/n = Value at POR and BOR/Value at all other Resets

'1' = Bit is set

'0' = Bit is cleared

bit 7-0 **SMTxCPW<23:16>**: Significant bits of the SMT PW Latch – Upper Byte

PIC16(L)F18856/76

REGISTER 32-16: SMTxPRL: SMT PERIOD REGISTER – LOW BYTE

R/W-x/1	R/W-x/1	R/W-x/1	R/W-x/1	R/W-x/1	R/W-x/1	R/W-x/1	R/W-x/1
SMTxPR<7:0>							
bit 7				bit 0			

Legend:

R = Readable bit

W = Writable bit

U = Unimplemented bit, read as '0'

u = Bit is unchanged

x = Bit is unknown

-n/n = Value at POR and BOR/Value at all other Resets

'1' = Bit is set

'0' = Bit is cleared

bit 7-0 **SMTxPR<7:0>**: Significant bits of the SMT Timer Value for Period Match – Low Byte

REGISTER 32-17: SMTxPRH: SMT PERIOD REGISTER – HIGH BYTE

R/W-x/1	R/W-x/1	R/W-x/1	R/W-x/1	R/W-x/1	R/W-x/1	R/W-x/1	R/W-x/1
SMTxPR<15:8>							
bit 7				bit 0			

Legend:

R = Readable bit

W = Writable bit

U = Unimplemented bit, read as '0'

u = Bit is unchanged

x = Bit is unknown

-n/n = Value at POR and BOR/Value at all other Resets

'1' = Bit is set

'0' = Bit is cleared

bit 7-0 **SMTxPR<15:8>**: Significant bits of the SMT Timer Value for Period Match – High Byte

REGISTER 32-18: SMTxPRU: SMT PERIOD REGISTER – UPPER BYTE

R/W-x/1	R/W-x/1	R/W-x/1	R/W-x/1	R/W-x/1	R/W-x/1	R/W-x/1	R/W-x/1
SMTxPR<23:16>							
bit 7				bit 0			

Legend:

R = Readable bit

W = Writable bit

U = Unimplemented bit, read as '0'

u = Bit is unchanged

x = Bit is unknown

-n/n = Value at POR and BOR/Value at all other Resets

'1' = Bit is set

'0' = Bit is cleared

bit 7-0 **SMTxPR<23:16>**: Significant bits of the SMT Timer Value for Period Match – Upper Byte

PIC16(L)F18856/76

TABLE 32-3: SUMMARY OF REGISTERS ASSOCIATED WITH SMTx

Name	Bit 7	Bit 6	Bit 5	Bit 4	Bit 3	Bit 2	Bit 1	Bit 0	Register on Page
PIE8	—	—	SMT2PWAIE	SMT2PRAIE	SMT2IE	SMT1PWAIE	SMT1PRAIE	SMT1IE	143
PIR8	—	—	SMT2PWAIF	SMT2PRAIF	SMT2IF	SMT1PWAIF	SMT1PRAIF	SMT1IF	153
SMT1TMRL	SMT1TMR<7:0>								549
SMT1TMRH	SMT1TMR<15:8>								549
SMT1TMRU	SMT1TMR<23:16>								549
SMT1CPRL	SMT1CPR<7:0>								550
SMT1CPRH	SMT1CPR<15:8>								550
SMT1CPRU	SMT1CPR<23:16>								550
SMT1CPWL	SMT1CPW<7:0>								551
SMT1CPWH	SMT1CPW<15:8>								551
SMT1CPWU	SMT1CPW<23:16>								551
SMT1PRL	SMT1PR<7:0>								552
SMT1PRH	SMT1PR<15:8>								552
SMT1PRU	SMT1PR<23:16>								552
SMT1CON0	EN	—	STP	WPOL	SPOL	CPOL	SMT1PS<1:0>		543
SMT1CON1	SMT1GO	REPEAT	—	—	MODE<3:0>				544
SMT1STAT	CPRUP	CPWUP	RST	—	—	TS	WS	AS	545
SMT1CLK	—	—	—	—	—	CSEL<2:0>			546
SMT1SIG	—	—	—	SSEL<4:0>					548
SMT1WIN	—	—	—	WSEL<4:0>					547
SMT2TMRL	SMT2TMR<7:0>								549
SMT2TMRH	SMT2TMR<15:8>								549
SMT2TMRU	SMT2TMR<23:16>								549
SMT2CPRL	SMT2CPR<7:0>								550
SMT2CPRH	SMT2CPR<15:8>								550
SMT2CPRU	SMT2CPR<23:16>								550
SMT2CPWL	SMT2CPW<7:0>								551
SMT2CPWH	SMT2CPW<15:8>								551
SMT2CPWU	SMT2CPW<23:16>								551
SMT2PRL	SMT2PR<7:0>								552
SMT2PRH	SMT2PR<15:8>								552
SMT2PRU	SMT2PR<23:16>								552
SMT2CON0	EN	—	STP	WPOL	SPOL	CPOL	SMT2PS<1:0>		543
SMT2CON1	SMT2GO	REPEAT	—	—	MODE<3:0>				544
SMT2STAT	CPRUP	CPWUP	RST	—	—	TS	WS	AS	545
SMT2CLK	—	—	—	—	—	CSEL<2:0>			546
SMT2SIG	—	—	—	SSEL<4:0>					548
SMT2WIN	—	—	—	WSEL<4:0>					547

Legend: — = unimplemented read as '0'. Shaded cells are not used for SMTx module.

PIC16(L)F18856/76

33.0 ENHANCED UNIVERSAL SYNCHRONOUS ASYNCHRONOUS RECEIVER TRANSMITTER (EUSART)

The Enhanced Universal Synchronous Asynchronous Receiver Transmitter (EUSART) module is a serial I/O communications peripheral. It contains all the clock generators, shift registers and data buffers necessary to perform an input or output serial data transfer independent of device program execution. The EUSART, also known as a Serial Communications Interface (SCI), can be configured as a full-duplex asynchronous system or half-duplex synchronous system. Full-Duplex mode is useful for communications with peripheral systems, such as CRT terminals and personal computers. Half-Duplex Synchronous mode is intended for communications with peripheral devices, such as A/D or D/A integrated circuits, serial EEPROMs or other microcontrollers. These devices typically do not have internal clocks for baud rate generation and require the external clock signal provided by a master synchronous device.

The EUSART module includes the following capabilities:

- Full-duplex asynchronous transmit and receive
- Two-character input buffer
- One-character output buffer
- Programmable 8-bit or 9-bit character length
- Address detection in 9-bit mode
- Input buffer overrun error detection
- Received character framing error detection
- Half-duplex synchronous master
- Half-duplex synchronous slave
- Programmable clock polarity in synchronous modes
- Sleep operation

The EUSART module implements the following additional features, making it ideally suited for use in Local Interconnect Network (LIN) bus systems:

- Automatic detection and calibration of the baud rate
- Wake-up on Break reception
- 13-bit Break character transmit

Block diagrams of the EUSART transmitter and receiver are shown in [Figure 33-1](#) and [Figure 33-2](#).

The EUSART transmit output (TX_out) is available to the TX/CK pin and internally to the following peripherals:

- Configurable Logic Cell (CLC)

FIGURE 33-1: EUSART TRANSMIT BLOCK DIAGRAM

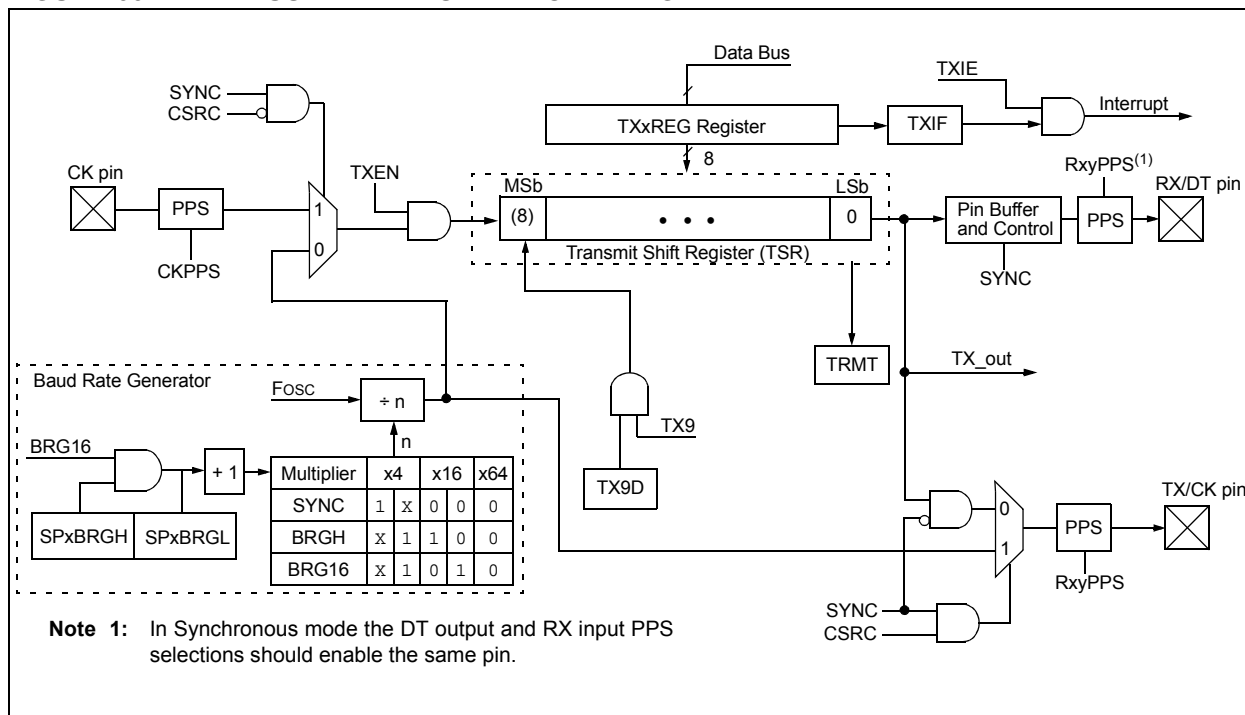

PIC16(L)F18856/76

FIGURE 33-2: EUSART RECEIVE BLOCK DIAGRAM

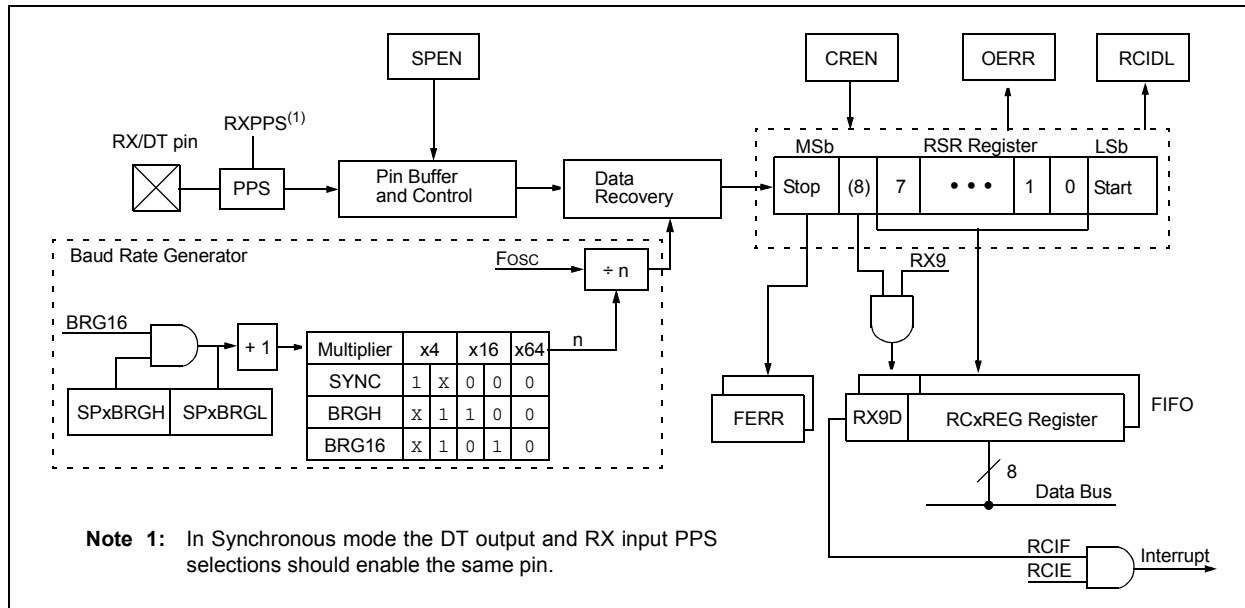

The operation of the EUSART module is controlled through three registers:

- Transmit Status and Control (TX1STA)
- Receive Status and Control (RC1STA)
- Baud Rate Control (BAUD1CON)

These registers are detailed in [Register 33-1](#), [Register 33-2](#) and [Register 33-3](#), respectively.

The RX input pin is selected with the RXPPS. The CK input is selected with the TXPPS register. TX, CK, and DT output pins are selected with each pin's RxyPPS register. Since the RX input is coupled with the DT output in Synchronous mode, it is the user's responsibility to select the same pin for both of these functions when operating in Synchronous mode. The EUSART control logic will control the data direction drivers automatically.

33.1 EUSART Asynchronous Mode

The EUSART transmits and receives data using the standard non-return-to-zero (NRZ) format. NRZ is implemented with two levels: a V_{OH} Mark state which represents a '1' data bit, and a V_{OL} Space state which represents a '0' data bit. NRZ refers to the fact that consecutively transmitted data bits of the same value stay at the output level of that bit without returning to a neutral level between each bit transmission. An NRZ transmission port idles in the Mark state. Each character transmission consists of one Start bit followed by eight or nine data bits and is always terminated by one or more Stop bits. The Start bit is always a space and the Stop bits are always marks. The most common data format is eight bits. Each transmitted bit persists for a period of 1/(Baud Rate). An on-chip dedicated 8-bit/16-bit Baud Rate Generator is used to derive standard baud rate frequencies from the system oscillator. See [Table 33-3](#) for examples of baud rate configurations.

The EUSART transmits and receives the LSb first. The EUSART's transmitter and receiver are functionally independent, but share the same data format and baud rate. Parity is not supported by the hardware, but can be implemented in software and stored as the ninth data bit.

33.1.1 EUSART ASYNCHRONOUS TRANSMITTER

The EUSART transmitter block diagram is shown in [Figure 33-1](#). The heart of the transmitter is the serial Transmit Shift Register (TSR), which is not directly accessible by software. The TSR obtains its data from the transmit buffer, which is the TXREG register.

33.1.1.1 Enabling the Transmitter

The EUSART transmitter is enabled for asynchronous operations by configuring the following three control bits:

- TXEN = 1
- SYNC = 0
- SPEN = 1

All other EUSART control bits are assumed to be in their default state.

Setting the TXEN bit of the TX1STA register enables the transmitter circuitry of the EUSART. Clearing the SYNC bit of the TX1STA register configures the EUSART for asynchronous operation. Setting the SPEN bit of the RC1STA register enables the EUSART and automatically configures the TX/CK I/O pin as an output. If the TX/CK pin is shared with an analog peripheral, the analog I/O function must be disabled by clearing the corresponding ANSEL bit.

Note: The TXIF Transmitter Interrupt flag is set when the TXEN enable bit is set.

33.1.1.2 Transmitting Data

A transmission is initiated by writing a character to the TXREG register. If this is the first character, or the previous character has been completely flushed from the TSR, the data in the TXREG is immediately transferred to the TSR register. If the TSR still contains all or part of a previous character, the new character data is held in the TXREG until the Stop bit of the previous character has been transmitted. The pending character in the TXREG is then transferred to the TSR in one T_{cy} immediately following the Stop bit transmission. The transmission of the Start bit, data bits and Stop bit sequence commences immediately following the transfer of the data to the TSR from the TXREG.

33.1.1.3 Transmit Data Polarity

The polarity of the transmit data can be controlled with the SCKP bit of the BAUD1CON register. The default state of this bit is '0' which selects high true transmit idle and data bits. Setting the SCKP bit to '1' will invert the transmit data resulting in low true idle and data bits. The SCKP bit controls transmit data polarity in Asynchronous mode only. In Synchronous mode, the SCKP bit has a different function. See [Section 33.4.1.2 "Clock Polarity"](#).

33.1.1.4 Transmit Interrupt Flag

The TXIF interrupt flag bit of the PIR3 register is set whenever the EUSART transmitter is enabled and no character is being held for transmission in the TXREG. In other words, the TXIF bit is only clear when the TSR is busy with a character and a new character has been queued for transmission in the TXREG. The TXIF flag bit is not cleared immediately upon writing TXREG. TXIF becomes valid in the second instruction cycle following the write execution. Polling TXIF immediately following the TXREG write will return invalid results. The TXIF bit is read-only, it cannot be set or cleared by software.

The TXIF interrupt can be enabled by setting the TXIE interrupt enable bit of the PIE3 register. However, the TXIF flag bit will be set whenever the TXREG is empty, regardless of the state of TXIE enable bit.

To use interrupts when transmitting data, set the TXIE bit only when there is more data to send. Clear the TXIE interrupt enable bit upon writing the last character of the transmission to the TXREG.

PIC16(L)F18856/76

33.1.1.5 TSR Status

The TRMT bit of the TX1STA register indicates the status of the TSR register. This is a read-only bit. The TRMT bit is set when the TSR register is empty and is cleared when a character is transferred to the TSR register from the TXREG. The TRMT bit remains clear until all bits have been shifted out of the TSR register. No interrupt logic is tied to this bit, so the user has to poll this bit to determine the TSR status.

Note: The TSR register is not mapped in data memory, so it is not available to the user.

33.1.1.6 Transmitting 9-Bit Characters

The EUSART supports 9-bit character transmissions. When the TX9 bit of the TX1STA register is set, the EUSART will shift nine bits out for each character transmitted. The TX9D bit of the TX1STA register is the ninth, and Most Significant data bit. When transmitting 9-bit data, the TX9D data bit must be written before writing the eight Least Significant bits into the TXREG. All nine bits of data will be transferred to the TSR shift register immediately after the TXREG is written.

A special 9-bit Address mode is available for use with multiple receivers. See [Section 33.1.2.7 “Address Detection”](#) for more information on the Address mode.

33.1.1.7 Asynchronous Transmission Set-up:

1. Initialize the SPBRGH, SPBRGL register pair and the BRGH and BRG16 bits to achieve the desired baud rate (see [Section 33.3 “EUSART Baud Rate Generator \(BRG\)”](#)).
2. Enable the asynchronous serial port by clearing the SYNC bit and setting the SPEN bit.
3. If 9-bit transmission is desired, set the TX9 control bit. A set ninth data bit will indicate that the eight Least Significant data bits are an address when the receiver is set for address detection.
4. Set SCKP bit if inverted transmit is desired.
5. Enable the transmission by setting the TXEN control bit. This will cause the TXIF interrupt bit to be set.
6. If interrupts are desired, set the TXIE interrupt enable bit of the PIE3 register. An interrupt will occur immediately provided that the GIE and PEIE bits of the INTCON register are also set.
7. If 9-bit transmission is selected, the ninth bit should be loaded into the TX9D data bit.
8. Load 8-bit data into the TXREG register. This will start the transmission.

FIGURE 33-3: ASYNCHRONOUS TRANSMISSION

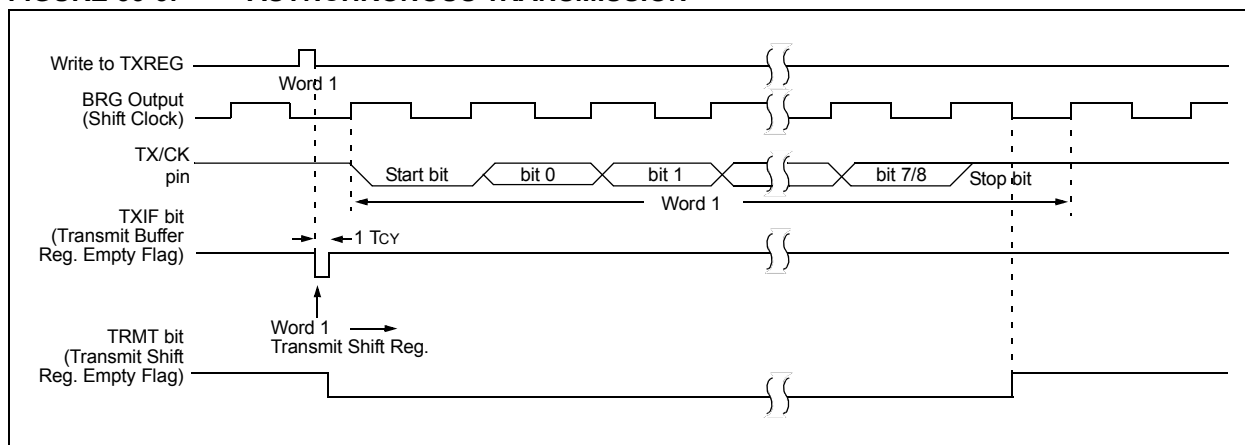

PIC16(L)F18856/76

FIGURE 33-4: ASYNCHRONOUS TRANSMISSION (BACK-TO-BACK)

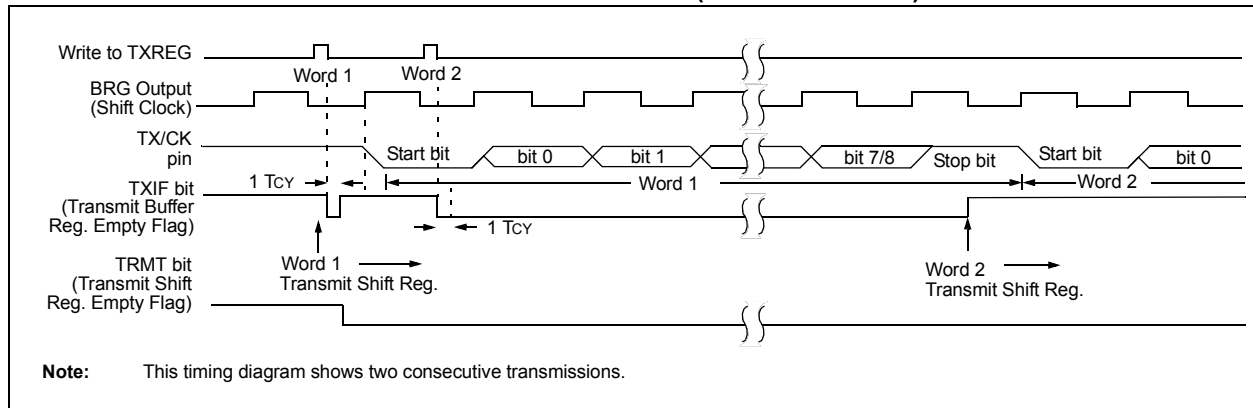

33.1.2 EUSART ASYNCHRONOUS RECEIVER

The Asynchronous mode is typically used in RS-232 systems. The receiver block diagram is shown in Figure 33-2. The data is received on the RX/DT pin and drives the data recovery block. The data recovery block is actually a high-speed shifter operating at 16 times the baud rate, whereas the serial Receive Shift Register (RSR) operates at the bit rate. When all eight or nine bits of the character have been shifted in, they are immediately transferred to a two character First-In-First-Out (FIFO) memory. The FIFO buffering allows reception of two complete characters and the start of a third character before software must start servicing the EUSART receiver. The FIFO and RSR registers are not directly accessible by software. Access to the received data is via the RCREG register.

33.1.2.1 Enabling the Receiver

The EUSART receiver is enabled for asynchronous operation by configuring the following three control bits:

- CREN = 1
- SYNC = 0
- SPEN = 1

All other EUSART control bits are assumed to be in their default state.

Setting the CREN bit of the RC1STA register enables the receiver circuitry of the EUSART. Clearing the SYNC bit of the TX1STA register configures the EUSART for asynchronous operation. Setting the SPEN bit of the RC1STA register enables the EUSART. The programmer must set the corresponding TRIS bit to configure the RX/DT I/O pin as an input.

Note: If the RX/DT function is on an analog pin, the corresponding ANSEL bit must be cleared for the receiver to function.

33.1.2.2 Receiving Data

The receiver data recovery circuit initiates character reception on the falling edge of the first bit. The first bit, also known as the Start bit, is always a zero. The data recovery circuit counts one-half bit time to the center of the Start bit and verifies that the bit is still a zero. If it is not a zero then the data recovery circuit aborts character reception, without generating an error, and resumes looking for the falling edge of the Start bit. If the Start bit zero verification succeeds then the data recovery circuit counts a full bit time to the center of the next bit. The bit is then sampled by a majority detect circuit and the resulting '0' or '1' is shifted into the RSR. This repeats until all data bits have been sampled and shifted into the RSR. One final bit time is measured and the level sampled. This is the Stop bit, which is always a '1'. If the data recovery circuit samples a '0' in the Stop bit position then a framing error is set for this character, otherwise the framing error is cleared for this character. See Section 33.1.2.4 "Receive Framing Error" for more information on framing errors.

Immediately after all data bits and the Stop bit have been received, the character in the RSR is transferred to the EUSART receive FIFO and the RCIF interrupt flag bit of the PIR3 register is set. The top character in the FIFO is transferred out of the FIFO by reading the RCREG register.

Note: If the receive FIFO is overrun, no additional characters will be received until the overrun condition is cleared. See Section 33.1.2.5 "Receive Overrun Error" for more information on overrun errors.

PIC16(L)F18856/76

33.1.2.3 Receive Interrupts

The RCIF interrupt flag bit of the PIR3 register is set whenever the EUSART receiver is enabled and there is an unread character in the receive FIFO. The RCIF interrupt flag bit is read-only, it cannot be set or cleared by software.

RCIF interrupts are enabled by setting all of the following bits:

- RCIE, Interrupt Enable bit of the PIE3 register
- PEIE, Peripheral Interrupt Enable bit of the INTCON register
- GIE, Global Interrupt Enable bit of the INTCON register

The RCIF interrupt flag bit will be set when there is an unread character in the FIFO, regardless of the state of interrupt enable bits.

33.1.2.4 Receive Framing Error

Each character in the receive FIFO buffer has a corresponding framing error Status bit. A framing error indicates that a Stop bit was not seen at the expected time. The framing error status is accessed via the FERR bit of the RC1STA register. The FERR bit represents the status of the top unread character in the receive FIFO. Therefore, the FERR bit must be read before reading the RCREG.

The FERR bit is read-only and only applies to the top unread character in the receive FIFO. A framing error (FERR = 1) does not preclude reception of additional characters. It is not necessary to clear the FERR bit. Reading the next character from the FIFO buffer will advance the FIFO to the next character and the next corresponding framing error.

The FERR bit can be forced clear by clearing the SPEN bit of the RC1STA register which resets the EUSART. Clearing the CREN bit of the RC1STA register does not affect the FERR bit. A framing error by itself does not generate an interrupt.

Note: If all receive characters in the receive FIFO have framing errors, repeated reads of the RCREG will not clear the FERR bit.
--

33.1.2.5 Receive Overrun Error

The receive FIFO buffer can hold two characters. An overrun error will be generated if a third character, in its entirety, is received before the FIFO is accessed. When this happens the OERR bit of the RC1STA register is set. The characters already in the FIFO buffer can be read but no additional characters will be received until the error is cleared. The error must be cleared by either clearing the CREN bit of the RC1STA register or by resetting the EUSART by clearing the SPEN bit of the RC1STA register.

33.1.2.6 Receiving 9-Bit Characters

The EUSART supports 9-bit character reception. When the RX9 bit of the RC1STA register is set the EUSART will shift nine bits into the RSR for each character received. The RX9D bit of the RC1STA register is the ninth and Most Significant data bit of the top unread character in the receive FIFO. When reading 9-bit data from the receive FIFO buffer, the RX9D data bit must be read before reading the eight Least Significant bits from the RCREG.

33.1.2.7 Address Detection

A special Address Detection mode is available for use when multiple receivers share the same transmission line, such as in RS-485 systems. Address detection is enabled by setting the ADDEN bit of the RC1STA register.

Address detection requires 9-bit character reception. When address detection is enabled, only characters with the ninth data bit set will be transferred to the receive FIFO buffer, thereby setting the RCIF interrupt bit. All other characters will be ignored.

Upon receiving an address character, user software determines if the address matches its own. Upon address match, user software must disable address detection by clearing the ADDEN bit before the next Stop bit occurs. When user software detects the end of the message, determined by the message protocol used, software places the receiver back into the Address Detection mode by setting the ADDEN bit.

PIC16(L)F18856/76

33.1.2.8 Asynchronous Reception Setup:

1. Initialize the SPBRGH, SPBRGL register pair and the BRGH and BRG16 bits to achieve the desired baud rate (see [Section 33.3 “EUSART Baud Rate Generator \(BRG\)”](#)).
2. Clear the ANSEL bit for the RX pin (if applicable).
3. Enable the serial port by setting the SPEN bit. The SYNC bit must be clear for asynchronous operation.
4. If interrupts are desired, set the RCIE bit of the PIE3 register and the GIE and PEIE bits of the INTCON register.
5. If 9-bit reception is desired, set the RX9 bit.
6. Enable reception by setting the CREN bit.
7. The RCIF interrupt flag bit will be set when a character is transferred from the RSR to the receive buffer. An interrupt will be generated if the RCIE interrupt enable bit was also set.
8. Read the RC1STA register to get the error flags and, if 9-bit data reception is enabled, the ninth data bit.
9. Get the received eight Least Significant data bits from the receive buffer by reading the RCREG register.
10. If an overrun occurred, clear the OERR flag by clearing the CREN receiver enable bit.

33.1.2.9 9-bit Address Detection Mode Setup

This mode would typically be used in RS-485 systems. To set up an Asynchronous Reception with Address Detect Enable:

1. Initialize the SPBRGH, SPBRGL register pair and the BRGH and BRG16 bits to achieve the desired baud rate (see [Section 33.3 “EUSART Baud Rate Generator \(BRG\)”](#)).
2. Clear the ANSEL bit for the RX pin (if applicable).
3. Enable the serial port by setting the SPEN bit. The SYNC bit must be clear for asynchronous operation.
4. If interrupts are desired, set the RCIE bit of the PIE3 register and the GIE and PEIE bits of the INTCON register.
5. Enable 9-bit reception by setting the RX9 bit.
6. Enable address detection by setting the ADDEN bit.
7. Enable reception by setting the CREN bit.
8. The RCIF interrupt flag bit will be set when a character with the ninth bit set is transferred from the RSR to the receive buffer. An interrupt will be generated if the RCIE interrupt enable bit was also set.
9. Read the RC1STA register to get the error flags. The ninth data bit will always be set.
10. Get the received eight Least Significant data bits from the receive buffer by reading the RCREG register. Software determines if this is the device's address.
11. If an overrun occurred, clear the OERR flag by clearing the CREN receiver enable bit.
12. If the device has been addressed, clear the ADDEN bit to allow all received data into the receive buffer and generate interrupts.

FIGURE 33-5: ASYNCHRONOUS RECEPTION

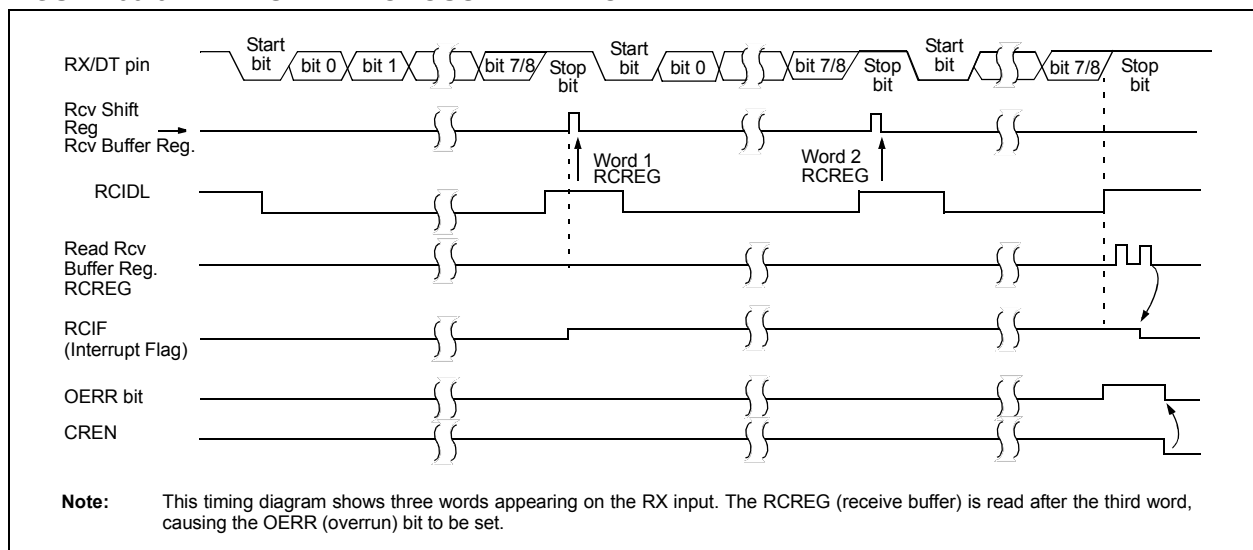

33.2 Clock Accuracy with Asynchronous Operation

The factory calibrates the internal oscillator block output (INTOSC). However, the INTOSC frequency may drift as V_{DD} or temperature changes, and this directly affects the asynchronous baud rate. Two methods may be used to adjust the baud rate clock, but both require a reference clock source of some kind.

The first (preferred) method uses the OSCTUNE register to adjust the INTOSC output. Adjusting the value in the OSCTUNE register allows for fine resolution changes to the system clock source. See [Section 6.2.2.2 “Internal Oscillator Frequency Adjustment”](#) for more information.

The other method adjusts the value in the Baud Rate Generator. This can be done automatically with the Auto-Baud Detect feature (see [Section 33.3.1 “Auto-Baud Detect”](#)). There may not be fine enough resolution when adjusting the Baud Rate Generator to compensate for a gradual change in the peripheral clock frequency.

PIC16(L)F18856/76

33.3 EUSART Baud Rate Generator (BRG)

The Baud Rate Generator (BRG) is an 8-bit or 16-bit timer that is dedicated to the support of both the asynchronous and synchronous EUSART operation. By default, the BRG operates in 8-bit mode. Setting the BRG16 bit of the BAUD1CON register selects 16-bit mode.

The SPBRGH, SPBRGL register pair determines the period of the free running baud rate timer. In Asynchronous mode the multiplier of the baud rate period is determined by both the BRGH bit of the TX1STA register and the BRG16 bit of the BAUD1CON register. In Synchronous mode, the BRGH bit is ignored.

Table 33-1 contains the formulas for determining the baud rate. Example 33-1 provides a sample calculation for determining the baud rate and baud rate error.

Typical baud rates and error values for various Asynchronous modes have been computed for your convenience and are shown in Table 33-3. It may be advantageous to use the high baud rate (BRGH = 1), or the 16-bit BRG (BRG16 = 1) to reduce the baud rate error. The 16-bit BRG mode is used to achieve slow baud rates for fast oscillator frequencies.

Writing a new value to the SPBRGH, SPBRGL register pair causes the BRG timer to be reset (or cleared). This ensures that the BRG does not wait for a timer overflow before outputting the new baud rate.

If the system clock is changed during an active receive operation, a receive error or data loss may result. To avoid this problem, check the status of the RCIDL bit to make sure that the receive operation is idle before changing the system clock.

EXAMPLE 33-1: CALCULATING BAUD RATE ERROR

For a device with Fosc of 16 MHz, desired baud rate of 9600, Asynchronous mode, 8-bit BRG:

$$\text{Desired Baud Rate} = \frac{F_{osc}}{64(SPBRGH:SPBRGL) + 1}$$

Solving for SPBRGH:SPBRGL:

$$X = \frac{F_{osc}}{\text{Desired Baud Rate} \cdot 64} - 1$$

$$= \frac{16000000}{9600 \cdot 64} - 1$$

$$= [25.042] = 25$$

$$\text{Calculated Baud Rate} = \frac{16000000}{64(25 + 1)}$$

$$= 9615$$

$$\text{Error} = \frac{\text{Calc. Baud Rate} - \text{Desired Baud Rate}}{\text{Desired Baud Rate}}$$

$$= \frac{(9615 - 9600)}{9600} = 0.16\%$$

PIC16(L)F18856/76

33.3.1 AUTO-BAUD DETECT

The EUSART module supports automatic detection and calibration of the baud rate.

In the Auto-Baud Detect (ABD) mode, the clock to the BRG is reversed. Rather than the BRG clocking the incoming RX signal, the RX signal is timing the BRG. The Baud Rate Generator is used to time the period of a received 55h (ASCII “U”) which is the Sync character for the LIN bus. The unique feature of this character is that it has five rising edges including the Stop bit edge.

Setting the ABDEN bit of the BAUD1CON register starts the auto-baud calibration sequence. While the ABD sequence takes place, the EUSART state machine is held in Idle. On the first rising edge of the receive line, after the Start bit, the SPBRG begins counting up using the BRG counter clock as shown in Figure 33-6. The fifth rising edge will occur on the RX pin at the end of the eighth bit period. At that time, an accumulated value totaling the proper BRG period is left in the SPBRGH, SPBRGL register pair, the ABDEN bit is automatically cleared and the RCIF interrupt flag is set. The value in the RCREG needs to be read to clear the RCIF interrupt. RCREG content should be discarded. When calibrating for modes that do not use the SPBRGH register the user can verify that the SPBRGL register did not overflow by checking for 00h in the SPBRGH register.

The BRG auto-baud clock is determined by the BRG16 and BRGH bits as shown in Table 33-1. During ABD, both the SPBRGH and SPBRGL registers are used as a 16-bit counter, independent of the BRG16 bit setting. While calibrating the baud rate period, the SPBRGH

and SPBRGL registers are clocked at 1/8th the BRG base clock rate. The resulting byte measurement is the average bit time when clocked at full speed.

Note 1: If the WUE bit is set with the ABDEN bit, auto-baud detection will occur on the byte following the Break character (see Section 33.3.3 “Auto-Wake-up on Break”).

2: It is up to the user to determine that the incoming character baud rate is within the range of the selected BRG clock source. Some combinations of oscillator frequency and EUSART baud rates are not possible.

3: During the auto-baud process, the auto-baud counter starts counting at one. Upon completion of the auto-baud sequence, to achieve maximum accuracy, subtract 1 from the SPBRGH:SPBRGL register pair.

TABLE 33-1: BRG COUNTER CLOCK RATES

BRG16	BRGH	BRG Base Clock	BRG ABD Clock
0	0	Fosc/64	Fosc/512
0	1	Fosc/16	Fosc/128
1	0	Fosc/16	Fosc/128
1	1	Fosc/4	Fosc/32

Note: During the ABD sequence, SPBRGL and SPBRGH registers are both used as a 16-bit counter, independent of the BRG16 setting.

FIGURE 33-6: AUTOMATIC BAUD RATE CALIBRATION

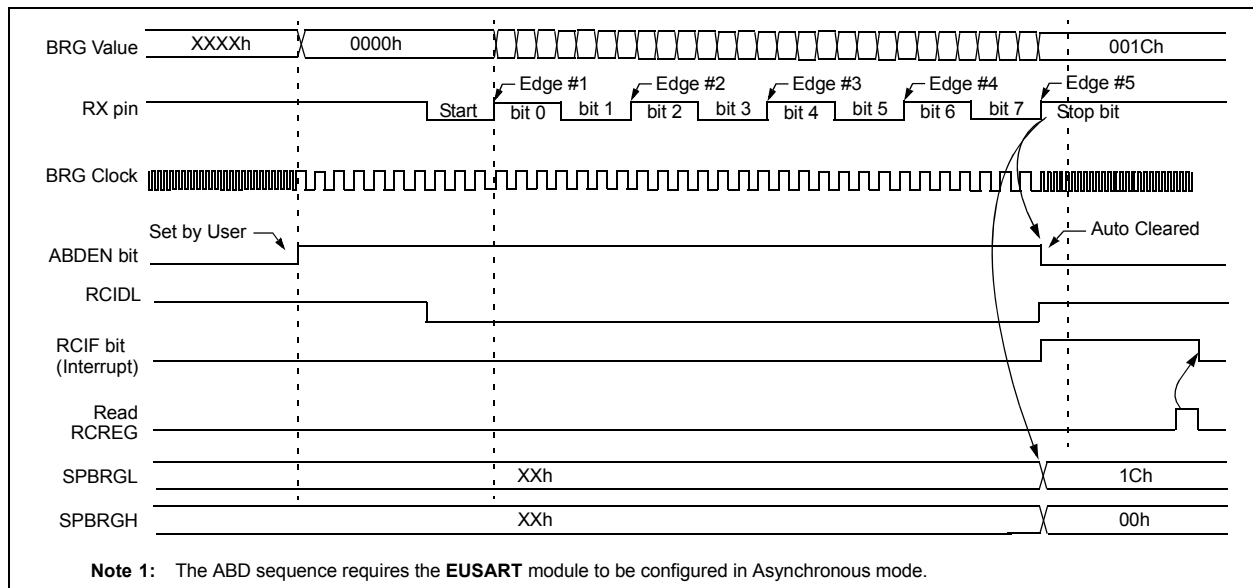

PIC16(L)F18856/76

33.3.2 AUTO-BAUD OVERFLOW

During the course of automatic baud detection, the ABDOVF bit of the BAUD1CON register will be set if the baud rate counter overflows before the fifth rising edge is detected on the RX pin. The ABDOVF bit indicates that the counter has exceeded the maximum count that can fit in the 16 bits of the SPBRGH:SPBRGL register pair. The overflow condition will set the RCIF flag. The counter continues to count until the fifth rising edge is detected on the RX pin. The RCIDL bit will remain false ('0') until the fifth rising edge at which time the RCIDL bit will be set. If the RCREG is read after the overflow occurs but before the fifth rising edge then the fifth rising edge will set the RCIF again.

Terminating the auto-baud process early to clear an overflow condition will prevent proper detection of the sync character fifth rising edge. If any falling edges of the sync character have not yet occurred when the ABDEN bit is cleared then those will be falsely detected as Start bits. The following steps are recommended to clear the overflow condition:

1. Read RCREG to clear RCIF.
2. If RCIDL is '0' then wait for RDCIF and repeat step 1.
3. Clear the ABDOVF bit.

33.3.3 AUTO-WAKE-UP ON BREAK

During Sleep mode, all clocks to the EUSART are suspended. Because of this, the Baud Rate Generator is inactive and a proper character reception cannot be performed. The Auto-Wake-up feature allows the controller to wake-up due to activity on the RX/DT line. This feature is available only in Asynchronous mode.

The Auto-Wake-up feature is enabled by setting the WUE bit of the BAUD1CON register. Once set, the normal receive sequence on RX/DT is disabled, and the EUSART remains in an Idle state, monitoring for a wake-up event independent of the CPU mode. A wake-up event consists of a high-to-low transition on the RX/DT line. (This coincides with the start of a Sync Break or a wake-up signal character for the LIN protocol.)

The EUSART module generates an RCIF interrupt coincident with the wake-up event. The interrupt is generated synchronously to the Q clocks in normal CPU operating modes (Figure 33-7), and asynchronously if the device is in Sleep mode (Figure 33-8). The interrupt condition is cleared by reading the RCREG register.

The WUE bit is automatically cleared by the low-to-high transition on the RX line at the end of the Break. This signals to the user that the Break event is over. At this point, the EUSART module is in IDLE mode waiting to receive the next character.

33.3.3.1 Special Considerations

Break Character

To avoid character errors or character fragments during a wake-up event, the wake-up character must be all zeros.

When the wake-up is enabled the function works independent of the low time on the data stream. If the WUE bit is set and a valid non-zero character is received, the low time from the Start bit to the first rising edge will be interpreted as the wake-up event. The remaining bits in the character will be received as a fragmented character and subsequent characters can result in framing or overrun errors.

Therefore, the initial character in the transmission must be all '0's. This must be ten or more bit times, 13-bit times recommended for LIN bus, or any number of bit times for standard RS-232 devices.

Oscillator Start-up Time

Oscillator start-up time must be considered, especially in applications using oscillators with longer start-up intervals (i.e., LP, XT or HS/PLL mode). The Sync Break (or wake-up signal) character must be of sufficient length, and be followed by a sufficient interval, to allow enough time for the selected oscillator to start and provide proper initialization of the EUSART.

WUE Bit

The wake-up event causes a receive interrupt by setting the RCIF bit. The WUE bit is cleared in hardware by a rising edge on RX/DT. The interrupt condition is then cleared in software by reading the RCREG register and discarding its contents.

To ensure that no actual data is lost, check the RCIDL bit to verify that a receive operation is not in process before setting the WUE bit. If a receive operation is not occurring, the WUE bit may then be set just prior to entering the Sleep mode.

PIC16(L)F18856/76

FIGURE 33-7: AUTO-WAKE-UP BIT (WUE) TIMING DURING NORMAL OPERATION

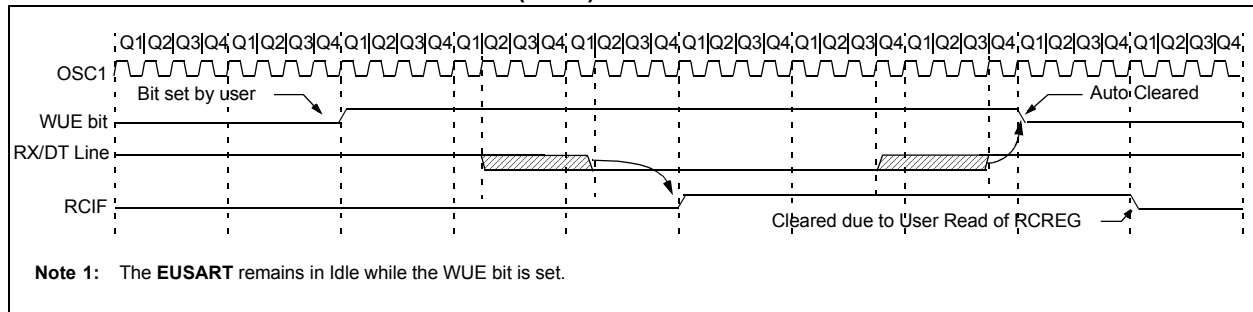
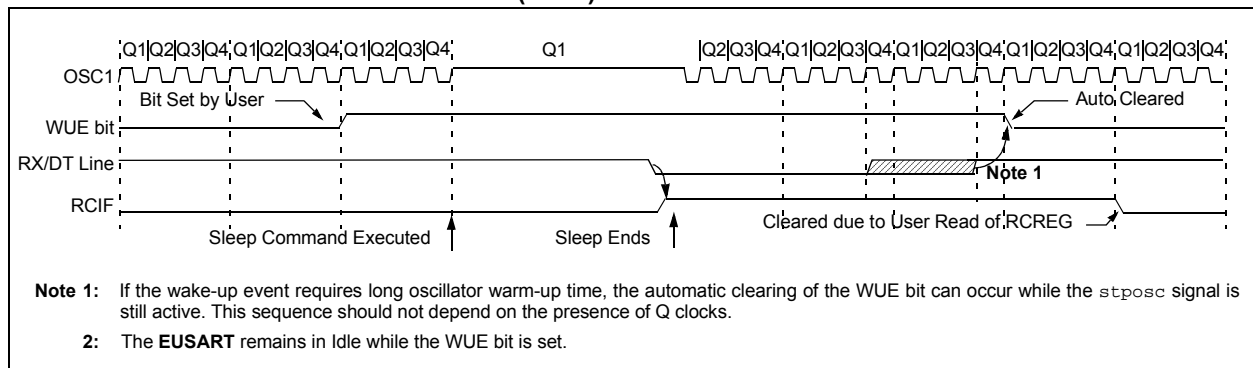

FIGURE 33-8: AUTO-WAKE-UP BIT (WUE) TIMINGS DURING SLEEP



33.3.4 BREAK CHARACTER SEQUENCE

The EUSART module has the capability of sending the special Break character sequences that are required by the LIN bus standard. A Break character consists of a Start bit, followed by 12 '0' bits and a Stop bit.

To send a Break character, set the SENDB and TXEN bits of the TX1STA register. The Break character transmission is then initiated by a write to the TXREG. The value of data written to TXREG will be ignored and all '0's will be transmitted.

The SENDB bit is automatically reset by hardware after the corresponding Stop bit is sent. This allows the user to preload the transmit FIFO with the next transmit byte following the Break character (typically, the Sync character in the LIN specification).

The TRMT bit of the TX1STA register indicates when the transmit operation is active or idle, just as it does during normal transmission. See [Figure 33-9](#) for the timing of the Break character sequence.

33.3.4.1 Break and Sync Transmit Sequence

The following sequence will start a message frame header made up of a Break, followed by an auto-baud Sync byte. This sequence is typical of a LIN bus master.

1. Configure the EUSART for the desired mode.
2. Set the TXEN and SENDB bits to enable the Break sequence.
3. Load the TXREG with a dummy character to initiate transmission (the value is ignored).
4. Write '55h' to TXREG to load the Sync character into the transmit FIFO buffer.
5. After the Break has been sent, the SENDB bit is reset by hardware and the Sync character is then transmitted.

When the TXREG becomes empty, as indicated by the TXIF, the next data byte can be written to TXREG.

PIC16(L)F18856/76

33.3.5 RECEIVING A BREAK CHARACTER

The Enhanced EUSART module can receive a Break character in two ways.

The first method to detect a Break character uses the FERR bit of the RC1STA register and the received data as indicated by RCREG. The Baud Rate Generator is assumed to have been initialized to the expected baud rate.

A Break character has been received when:

- RCIF bit is set
- FERR bit is set
- RCREG = 00h

The second method uses the Auto-Wake-up feature described in [Section 33.3.3 “Auto-Wake-up on Break”](#). By enabling this feature, the EUSART will sample the next two transitions on RX/DT, cause an RCIF interrupt, and receive the next data byte followed by another interrupt.

Note that following a Break character, the user will typically want to enable the Auto-Baud Detect feature. For both methods, the user can set the ABDEN bit of the BAUD1CON register before placing the EUSART in Sleep mode.

FIGURE 33-9: SEND BREAK CHARACTER SEQUENCE

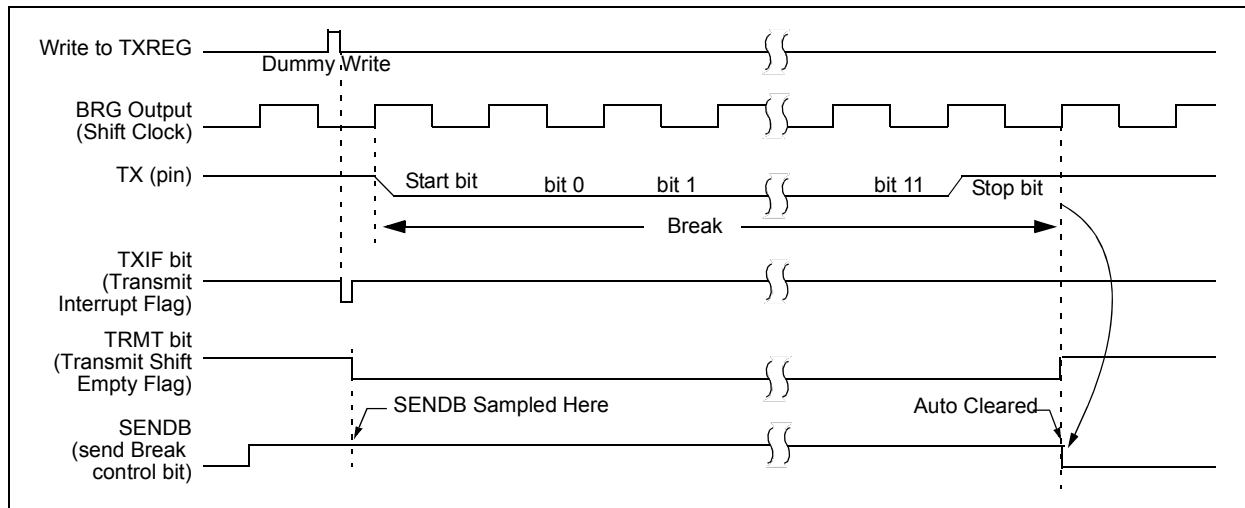

33.4 EUSART Synchronous Mode

Synchronous serial communications are typically used in systems with a single master and one or more slaves. The master device contains the necessary circuitry for baud rate generation and supplies the clock for all devices in the system. Slave devices can take advantage of the master clock by eliminating the internal clock generation circuitry.

There are two signal lines in Synchronous mode: a bidirectional data line and a clock line. Slaves use the external clock supplied by the master to shift the serial data into and out of their respective receive and transmit shift registers. Since the data line is bidirectional, synchronous operation is half-duplex only. Half-duplex refers to the fact that master and slave devices can receive and transmit data but not both simultaneously. The EUSART can operate as either a master or slave device.

Start and Stop bits are not used in synchronous transmissions.

33.4.1 SYNCHRONOUS MASTER MODE

The following bits are used to configure the EUSART for synchronous master operation:

- SYNC = 1
- CSRC = 1
- SREN = 0 (for transmit); SREN = 1 (for receive)
- CREN = 0 (for transmit); CREN = 1 (for receive)
- SPEN = 1

Setting the SYNC bit of the TX1STA register configures the device for synchronous operation. Setting the CSRC bit of the TX1STA register configures the device as a master. Clearing the SREN and CREN bits of the RC1STA register ensures that the device is in the Transmit mode, otherwise the device will be configured to receive. Setting the SPEN bit of the RC1STA register enables the EUSART.

33.4.1.1 Master Clock

Synchronous data transfers use a separate clock line, which is synchronous with the data. A device configured as a master transmits the clock on the TX/CK line. The TX/CK pin output driver is automatically enabled when the EUSART is configured for synchronous transmit or receive operation. Serial data bits change on the leading edge to ensure they are valid at the trailing edge of each clock. One clock cycle is generated for each data bit. Only as many clock cycles are generated as there are data bits.

33.4.1.2 Clock Polarity

A clock polarity option is provided for Microwire compatibility. Clock polarity is selected with the SCKP bit of the BAUD1CON register. Setting the SCKP bit sets the clock Idle state as high. When the SCKP bit is set, the data changes on the falling edge of each clock. Clearing the SCKP bit sets the Idle state as low. When the SCKP bit is cleared, the data changes on the rising edge of each clock.

33.4.1.3 Synchronous Master Transmission

Data is transferred out of the device on the RX/DT pin. The RX/DT and TX/CK pin output drivers are automatically enabled when the EUSART is configured for synchronous master transmit operation.

A transmission is initiated by writing a character to the TXREG register. If the TSR still contains all or part of a previous character the new character data is held in the TXREG until the last bit of the previous character has been transmitted. If this is the first character, or the previous character has been completely flushed from the TSR, the data in the TXREG is immediately transferred to the TSR. The transmission of the character commences immediately following the transfer of the data to the TSR from the TXREG.

Each data bit changes on the leading edge of the master clock and remains valid until the subsequent leading clock edge.

Note: The TSR register is not mapped in data memory, so it is not available to the user.

33.4.1.4 Synchronous Master Transmission Set-up:

1. Initialize the SPBRGH, SPBRGL register pair and the BRGH and BRG16 bits to achieve the desired baud rate (see [Section 33.3 “EUSART Baud Rate Generator \(BRG\)”](#)).
2. Enable the synchronous master serial port by setting bits SYNC, SPEN and CSRC.
3. Disable Receive mode by clearing bits SREN and CREN.
4. Enable Transmit mode by setting the TXEN bit.
5. If 9-bit transmission is desired, set the TX9 bit.
6. If interrupts are desired, set the TXIE bit of the PIE3 register and the GIE and PEIE bits of the INTCON register.
7. If 9-bit transmission is selected, the ninth bit should be loaded in the TX9D bit.
8. Start transmission by loading data to the TXREG register.

PIC16(L)F18856/76

FIGURE 33-10: SYNCHRONOUS TRANSMISSION

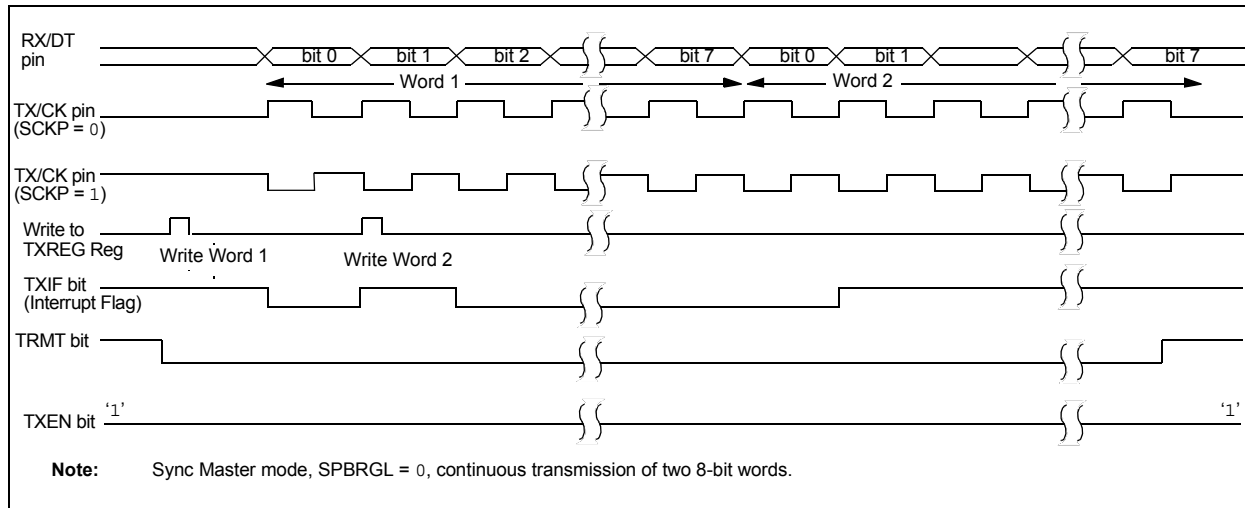
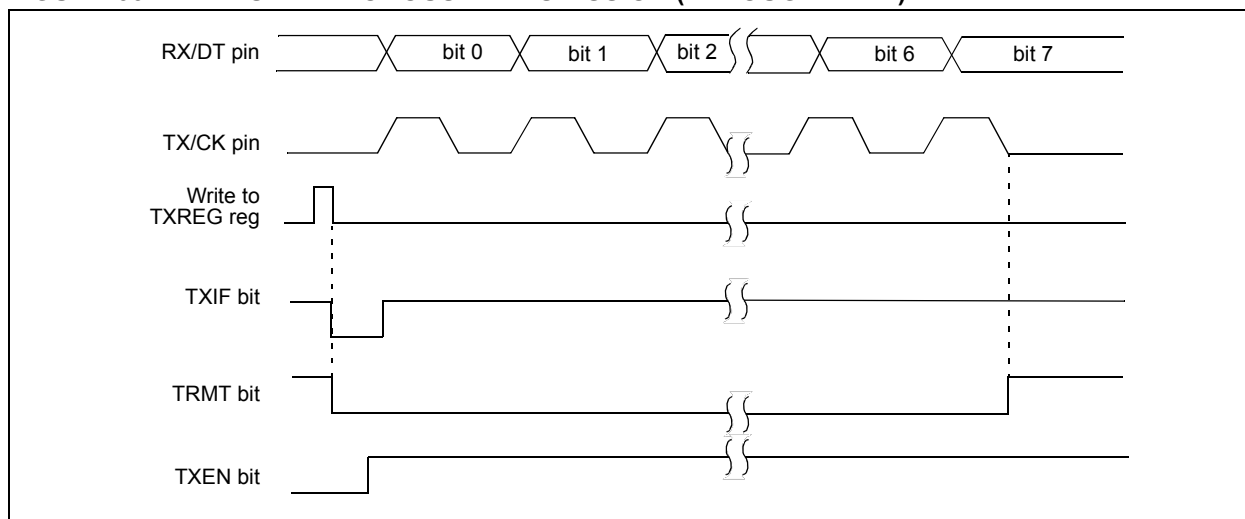

FIGURE 33-11: SYNCHRONOUS TRANSMISSION (THROUGH TXEN)



33.4.1.5 Synchronous Master Reception

Data is received at the RX/DT pin. The RX/DT pin output driver is automatically disabled when the EUSART is configured for synchronous master receive operation.

In Synchronous mode, reception is enabled by setting either the Single Receive Enable bit (SREN of the RC1STA register) or the Continuous Receive Enable bit (CREN of the RC1STA register).

When SREN is set and CREN is clear, only as many clock cycles are generated as there are data bits in a single character. The SREN bit is automatically cleared at the completion of one character. When CREN is set, clocks are continuously generated until CREN is cleared. If CREN is cleared in the middle of a character the CK clock stops immediately and the partial character is discarded. If SREN and CREN are both set, then SREN is cleared at the completion of the first character and CREN takes precedence.

To initiate reception, set either SREN or CREN. Data is sampled at the RX/DT pin on the trailing edge of the TX/CK clock pin and is shifted into the Receive Shift Register (RSR). When a complete character is received into the RSR, the RCIF bit is set and the character is automatically transferred to the two character receive FIFO. The Least Significant eight bits of the top character in the receive FIFO are available in RCREG. The RCIF bit remains set as long as there are unread characters in the receive FIFO.

Note: If the RX/DT function is on an analog pin, the corresponding ANSEL bit must be cleared for the receiver to function.

PIC16(L)F18856/76

33.4.1.6 Slave Clock

Synchronous data transfers use a separate clock line, which is synchronous with the data. A device configured as a slave receives the clock on the TX/CK line. The TX/CK pin output driver is automatically disabled when the device is configured for synchronous slave transmit or receive operation. Serial data bits change on the leading edge to ensure they are valid at the trailing edge of each clock. One data bit is transferred for each clock cycle. Only as many clock cycles should be received as there are data bits.

Note: If the device is configured as a slave and the TX/CK function is on an analog pin, the corresponding ANSEL bit must be cleared.

33.4.1.7 Receive Overrun Error

The receive FIFO buffer can hold two characters. An overrun error will be generated if a third character, in its entirety, is received before RCREG is read to access the FIFO. When this happens the OERR bit of the RC1STA register is set. Previous data in the FIFO will not be overwritten. The two characters in the FIFO buffer can be read, however, no additional characters will be received until the error is cleared. The OERR bit can only be cleared by clearing the overrun condition. If the overrun error occurred when the SREN bit is set and CREN is clear then the error is cleared by reading RCREG. If the overrun occurred when the CREN bit is set then the error condition is cleared by either clearing the CREN bit of the RC1STA register or by clearing the SPEN bit which resets the EUSART.

33.4.1.8 Receiving 9-bit Characters

The EUSART supports 9-bit character reception. When the RX9 bit of the RC1STA register is set the EUSART will shift nine bits into the RSR for each character

received. The RX9D bit of the RC1STA register is the ninth, and Most Significant, data bit of the top unread character in the receive FIFO. When reading 9-bit data from the receive FIFO buffer, the RX9D data bit must be read before reading the eight Least Significant bits from the RCREG.

33.4.1.9 Synchronous Master Reception Set-up:

1. Initialize the SPBRGH, SPBRGL register pair for the appropriate baud rate. Set or clear the BRGH and BRG16 bits, as required, to achieve the desired baud rate.
2. Clear the ANSEL bit for the RX pin (if applicable).
3. Enable the synchronous master serial port by setting bits SYNC, SPEN and CSRC.
4. Ensure bits CREN and SREN are clear.
5. If interrupts are desired, set the RCIE bit of the PIE3 register and the GIE and PEIE bits of the INTCON register.
6. If 9-bit reception is desired, set bit RX9.
7. Start reception by setting the SREN bit or for continuous reception, set the CREN bit.
8. Interrupt flag bit RCIF will be set when reception of a character is complete. An interrupt will be generated if the enable bit RCIE was set.
9. Read the RC1STA register to get the ninth bit (if enabled) and determine if any error occurred during reception.
10. Read the 8-bit received data by reading the RCREG register.
11. If an overrun error occurs, clear the error by either clearing the CREN bit of the RC1STA register or by clearing the SPEN bit which resets the EUSART.

FIGURE 33-12: SYNCHRONOUS RECEPTION (MASTER MODE, SREN)

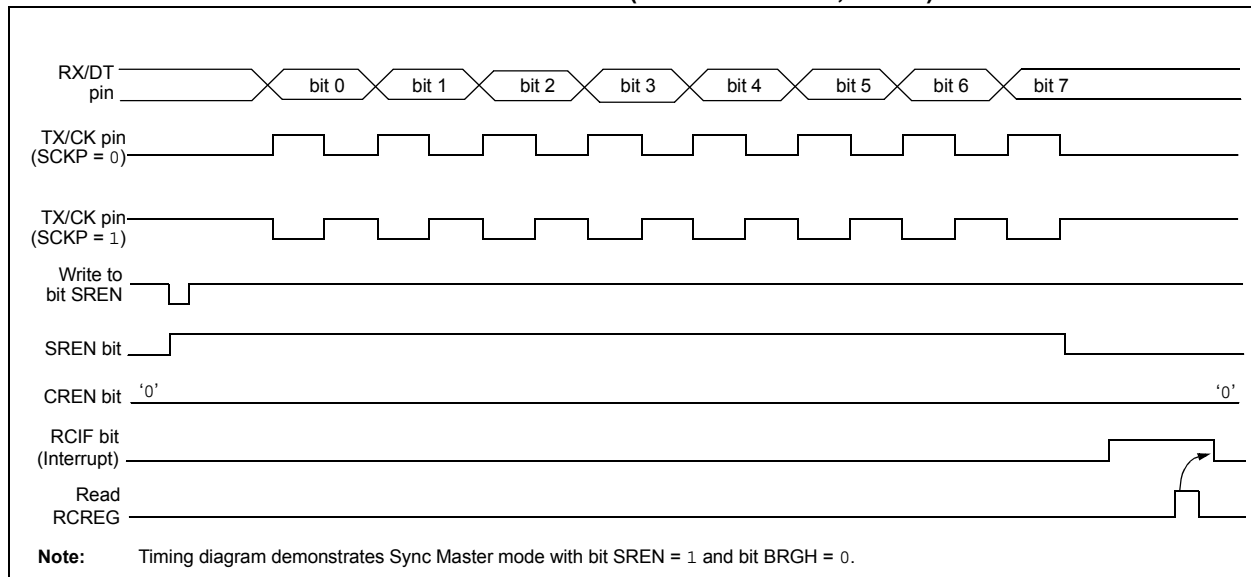

33.4.2 SYNCHRONOUS SLAVE MODE

The following bits are used to configure the EUSART for synchronous slave operation:

- SYNC = 1
- CSRC = 0
- SREN = 0 (for transmit); SREN = 1 (for receive)
- CREN = 0 (for transmit); CREN = 1 (for receive)
- SPEN = 1

Setting the SYNC bit of the TX1STA register configures the device for synchronous operation. Clearing the CSRC bit of the TX1STA register configures the device as a slave. Clearing the SREN and CREN bits of the RC1STA register ensures that the device is in the Transmit mode, otherwise the device will be configured to receive. Setting the SPEN bit of the RC1STA register enables the EUSART.

33.4.2.1 EUSART Synchronous Slave Transmit

The operation of the Synchronous Master and Slave modes are identical (see [Section 33.4.1.3 “Synchronous Master Transmission”](#)), except in the case of the Sleep mode.

If two words are written to the TXREG and then the SLEEP instruction is executed, the following will occur:

1. The first character will immediately transfer to the TSR register and transmit.
2. The second word will remain in the TXREG register.
3. The TXIF bit will not be set.
4. After the first character has been shifted out of TSR, the TXREG register will transfer the second character to the TSR and the TXIF bit will now be set.
5. If the PEIE and TXIE bits are set, the interrupt will wake the device from Sleep and execute the next instruction. If the GIE bit is also set, the program will call the Interrupt Service Routine.

33.4.2.2 Synchronous Slave Transmission Set-up:

1. Set the SYNC and SPEN bits and clear the CSRC bit.
2. Clear the ANSEL bit for the CK pin (if applicable).
3. Clear the CREN and SREN bits.
4. If interrupts are desired, set the TXIE bit of the PIE3 register and the GIE and PEIE bits of the INTCON register.
5. If 9-bit transmission is desired, set the TX9 bit.
6. Enable transmission by setting the TXEN bit.
7. If 9-bit transmission is selected, insert the Most Significant bit into the TX9D bit.
8. Start transmission by writing the Least Significant eight bits to the TXREG register.

PIC16(L)F18856/76

33.4.2.3 EUSART Synchronous Slave Reception

The operation of the Synchronous Master and Slave modes is identical ([Section 33.4.1.5 “Synchronous Master Reception”](#)), with the following exceptions:

- Sleep
- CREN bit is always set, therefore the receiver is never idle
- SREN bit, which is a “don’t care” in Slave mode

A character may be received while in Sleep mode by setting the CREN bit prior to entering Sleep. Once the word is received, the RSR register will transfer the data to the RCREG register. If the RCIE enable bit is set, the interrupt generated will wake the device from Sleep and execute the next instruction. If the GIE bit is also set, the program will branch to the interrupt vector.

33.4.2.4 Synchronous Slave Reception Set-up:

1. Set the SYNC and SPEN bits and clear the CSRC bit.
2. Clear the ANSEL bit for both the CK and DT pins (if applicable).
3. If interrupts are desired, set the RCIE bit of the PIE3 register and the GIE and PEIE bits of the INTCON register.
4. If 9-bit reception is desired, set the RX9 bit.
5. Set the CREN bit to enable reception.
6. The RCIF bit will be set when reception is complete. An interrupt will be generated if the RCIE bit was set.
7. If 9-bit mode is enabled, retrieve the Most Significant bit from the RX9D bit of the RC1STA register.
8. Retrieve the eight Least Significant bits from the receive FIFO by reading the RCREG register.
9. If an overrun error occurs, clear the error by either clearing the CREN bit of the RC1STA register or by clearing the SPEN bit which resets the EUSART.

33.5 EUSART Operation During Sleep

The EUSART will remain active during Sleep only in the Synchronous Slave mode. All other modes require the system clock and therefore cannot generate the necessary signals to run the Transmit or Receive Shift registers during Sleep.

Synchronous Slave mode uses an externally generated clock to run the Transmit and Receive Shift registers.

33.5.1 SYNCHRONOUS RECEIVE DURING SLEEP

To receive during Sleep, all the following conditions must be met before entering Sleep mode:

- RC1STA and TX1STA Control registers must be configured for Synchronous Slave Reception (see [Section 33.4.2.4 “Synchronous Slave Reception Set-up:”](#)).
- If interrupts are desired, set the RCIE bit of the PIE3 register and the GIE and PEIE bits of the INTCON register.
- The RCIF interrupt flag must be cleared by reading RCREG to unload any pending characters in the receive buffer.

Upon entering Sleep mode, the device will be ready to accept data and clocks on the RX/DT and TX/CK pins, respectively. When the data word has been completely clocked in by the external device, the RCIF interrupt flag bit of the PIR3 register will be set. Thereby, waking the processor from Sleep.

Upon waking from Sleep, the instruction following the SLEEP instruction will be executed. If the Global Interrupt Enable (GIE) bit of the INTCON register is also set, then the Interrupt Service Routine at address 004h will be called.

33.5.2 SYNCHRONOUS TRANSMIT DURING SLEEP

To transmit during Sleep, all the following conditions must be met before entering Sleep mode:

- The RC1STA and TX1STA Control registers must be configured for synchronous slave transmission (see [Section 33.4.2.2 “Synchronous Slave Transmission Set-up:”](#)).
- The TXIF interrupt flag must be cleared by writing the output data to the TXREG, thereby filling the TSR and transmit buffer.
- If interrupts are desired, set the TXIE bit of the PIE3 register and the PEIE bit of the INTCON register.
- Interrupt enable bits TXIE of the PIE3 register and PEIE of the INTCON register must set.

Upon entering Sleep mode, the device will be ready to accept clocks on TX/CK pin and transmit data on the RX/DT pin. When the data word in the TSR has been completely clocked out by the external device, the pending byte in the TXREG will transfer to the TSR and the TXIF flag will be set. Thereby, waking the processor from Sleep. At this point, the TXREG is available to accept another character for transmission, which will clear the TXIF flag.

Upon waking from Sleep, the instruction following the SLEEP instruction will be executed. If the Global Interrupt Enable (GIE) bit is also set then the Interrupt Service Routine at address 0004h will be called.

PIC16(L)F18856/76

33.6 Register Definitions: EUSART Control

REGISTER 33-1: TX1STA: TRANSMIT STATUS AND CONTROL REGISTER

R/W-/0	R/W-0/0	R/W-0/0	R/W-0/0	R/W-0/0	R/W-0/0	R-1/1	R/W-0/0
CSRC	TX9	TXEN ⁽¹⁾	SYNC	SENDB	BRGH	TRMT	TX9D
bit 7							bit 0

Legend:

R = Readable bit

W = Writable bit

U = Unimplemented bit, read as '0'

u = Bit is unchanged

x = Bit is unknown

-n/n = Value at POR and BOR/Value at all other Resets

'1' = Bit is set

'0' = Bit is cleared

bit 7	CSRC: Clock Source Select bit <u>Asynchronous mode:</u> Unused in this mode – value ignored <u>Synchronous mode:</u> 1 = Master mode (clock generated internally from BRG) 0 = Slave mode (clock from external source)
bit 6	TX9: 9-bit Transmit Enable bit 1 = Selects 9-bit transmission 0 = Selects 8-bit transmission
bit 5	TXEN: Transmit Enable bit ⁽¹⁾ 1 = Transmit enabled 0 = Transmit disabled
bit 4	SYNC: EUSART Mode Select bit 1 = Synchronous mode 0 = Asynchronous mode
bit 3	SENDB: Send Break Character bit <u>Asynchronous mode:</u> 1 = Send SYNCH BREAK on next transmission – start bit, followed by 12 '0' bits, followed by Stop bit; cleared by hardware upon completion 0 = SYNCH BREAK transmission disabled or completed <u>Synchronous mode:</u> Unused in this mode – value ignored
bit 2	BRGH: High Baud Rate Select bit <u>Asynchronous mode:</u> 1 = High speed 0 = Low speed <u>Synchronous mode:</u> Unused in this mode – value ignored
bit 1	TRMT: Transmit Shift Register Status bit 1 = TSR empty 0 = TSR full
bit 0	TX9D: Ninth bit of Transmit Data Can be address/data bit or a parity bit.

Note 1: SREN/CREN overrides TXEN in Sync mode.

PIC16(L)F18856/76

REGISTER 33-2: RC1STA: RECEIVE STATUS AND CONTROL REGISTER

R/W-0/0	R/W-0/0	R/W-0/0	R/W-0/0	R/W-0/0	R-0/0	R-0/0	R-0/0
SPEN ⁽¹⁾	RX9	SREN	CREN	ADDEN	FERR	OERR	RX9D
bit 7							bit 0

Legend:

R = Readable bit

W = Writable bit

U = Unimplemented bit, read as '0'

u = Bit is unchanged

x = Bit is unknown

-n/n = Value at POR and BOR/Value at all other Resets

'1' = Bit is set

'0' = Bit is cleared

- bit 7 **SPEN:** Serial Port Enable bit⁽¹⁾
1 = Serial port enabled
0 = Serial port disabled (held in Reset)
- bit 6 **RX9:** 9-Bit Receive Enable bit
1 = Selects 9-bit reception
0 = Selects 8-bit reception
- bit 5 **SREN:** Single Receive Enable bit
Asynchronous mode:
Unused in this mode – value ignored
Synchronous mode – Master:
1 = Enables single receive
0 = Disables single receive
This bit is cleared after reception is complete.
Synchronous mode – Slave
Unused in this mode – value ignored
- bit 4 **CREN:** Continuous Receive Enable bit
Asynchronous mode:
1 = Enables continuous receive until enable bit CREN is cleared
0 = Disables continuous receive
Synchronous mode:
1 = Enables continuous receive until enable bit CREN is cleared (CREN overrides SREN)
0 = Disables continuous receive
- bit 3 **ADDEN:** Address Detect Enable bit
Asynchronous mode 9-bit (RX9 = 1):
1 = Enables address detection – enable interrupt and load of the receive buffer when the ninth bit in the receive buffer is set
0 = Disables address detection, all bytes are received and ninth bit can be used as parity bit
Asynchronous mode 8-bit (RX9 = 0):
Unused in this mode – value ignored
- bit 2 **FERR:** Framing Error bit
1 = Framing error (can be updated by reading RCREG register and receive next valid byte)
0 = No framing error
- bit 1 **OERR:** Overrun Error bit
1 = Overrun error (can be cleared by clearing bit CREN)
0 = No overrun error
- bit 0 **RX9D:** Ninth bit of Received Data
This can be address/data bit or a parity bit and must be calculated by user firmware.

Note 1: The EUSART module automatically changes the pin from tri-state to drive as needed. Configure the associated TRIS bits for TX/CK and RX/DT to 1.

PIC16(L)F18856/76

REGISTER 33-3: BAUD1CON: BAUD RATE CONTROL REGISTER

R-0/0	R-1/1	U-0	R/W-0/0	R/W-0/0	U-0	R/W-0/0	R/W-0/0
ABDOVF	RCIDL	—	SCKP	BRG16	—	WUE	ABDEN
bit 7							bit 0

Legend:

R = Readable bit

W = Writable bit

U = Unimplemented bit, read as '0'

u = Bit is unchanged

x = Bit is unknown

-n/n = Value at POR and BOR/Value at all other Resets

'1' = Bit is set

'0' = Bit is cleared

- bit 7 **ABDOVF:** Auto-Baud Detect Overflow bit
Asynchronous mode:
 1 = Auto-baud timer overflowed
 0 = Auto-baud timer did not overflow
Synchronous mode:
 Don't care
- bit 6 **RCIDL:** Receive Idle Flag bit
Asynchronous mode:
 1 = Receiver is Idle
 0 = Start bit has been received and the receiver is receiving
Synchronous mode:
 Don't care
- bit 5 **Unimplemented:** Read as '0'
- bit 4 **SCKP:** Clock/Transmit Polarity Select bit
Asynchronous mode:
 1 = Idle state for transmit (TX) is a low level
 0 = Idle state for transmit (TX) is a high level
Synchronous mode:
 1 = Idle state for clock (CK) is a high level
 0 = Idle state for clock (CK) is a low level
- bit 3 **BRG16:** 16-bit Baud Rate Generator bit
 1 = 16-bit Baud Rate Generator is used
 0 = 8-bit Baud Rate Generator is used
- bit 2 **Unimplemented:** Read as '0'
- bit 1 **WUE:** Wake-up Enable bit
Asynchronous mode:
 1 = USART will continue to sample the Rx pin – interrupt generated on falling edge; bit cleared in hardware on following rising edge.
 0 = RX pin not monitored nor rising edge detected
Synchronous mode:
 Unused in this mode – value ignored
- bit 0 **ABDEN:** Auto-Baud Detect Enable bit
Asynchronous mode:
 1 = Enable baud rate measurement on the next character – requires reception of a SYNCH field (55h);
 cleared in hardware upon completion
 0 = Baud rate measurement disabled or completed
Synchronous mode:
 Unused in this mode – value ignored

PIC16(L)F18856/76

REGISTER 33-4: RC1REG⁽¹⁾: RECEIVE DATA REGISTER

R-0	R-0	R-0	R-0	R-0	R-0	R-0	R-0
RC1REG<7:0>							
bit 7							bit 0

Legend:

R = Readable bit	W = Writable bit	U = Unimplemented bit, read as '0'
u = Bit is unchanged	x = Bit is unknown	-n/n = Value at POR and BOR/Value at all other Resets
'1' = Bit is set	'0' = Bit is cleared	

bit 7-0 **RC1REG<7:0>**: Lower eight bits of the received data; read-only; see also RX9D ([Register 33-2](#))

Note 1: RCREG (including the 9th bit) is double buffered, and data is available while new data is being received.

REGISTER 33-5: TX1REG⁽¹⁾: TRANSMIT DATA REGISTER

R/W-0	R/W-0	R/W-0	R/W-0	R/W-0	R/W-0	R/W-0	R/W-0
TX1REG<7:0>							
bit 7							bit 0

Legend:

R = Readable bit	W = Writable bit	U = Unimplemented bit, read as '0'
u = Bit is unchanged	x = Bit is unknown	-n/n = Value at POR and BOR/Value at all other Resets
'1' = Bit is set	'0' = Bit is cleared	

bit 7-0 **TX1REG<7:0>**: Lower eight bits of the received data; read-only; see also RX9D ([Register 33-1](#))

Note 1: TXREG (including the 9th bit) is double buffered, and can be written when previous data has started shifting.

REGISTER 33-6: SP1BRGL⁽¹⁾: BAUD RATE GENERATOR REGISTER

R/W-0	R/W-0	R/W-0	R/W-0	R/W-0	R/W-0	R/W-0	R/W-0
SP1BRG<7:0>							
bit 7							bit 0

Legend:

R = Readable bit	W = Writable bit	U = Unimplemented bit, read as '0'
u = Bit is unchanged	x = Bit is unknown	-n/n = Value at POR and BOR/Value at all other Resets
'1' = Bit is set	'0' = Bit is cleared	

bit 7-0 **SP1BRG<7:0>**: Lower eight bits of the Baud Rate Generator

Note 1: Writing to SP1BRG resets the BRG counter.

PIC16(L)F18856/76

REGISTER 33-7: SP1BRGH^(1, 2): BAUD RATE GENERATOR HIGH REGISTER

R/W-0	R/W-0	R/W-0	R/W-0	R/W-0	R/W-0	R/W-0	R/W-0
SP1BRG<15:8>							
bit 7							bit 0

Legend:

R = Readable bit

W = Writable bit

U = Unimplemented bit, read as '0'

u = Bit is unchanged

x = Bit is unknown

-n/n = Value at POR and BOR/Value at all other Resets

'1' = Bit is set

'0' = Bit is cleared

bit 7 **SP1BRG<15:8>**: Upper eight bits of the Baud Rate Generator

Note 1: SPBRGH value is ignored for all modes unless BAUD1CON<BRG16> is active.

2: Writing to SPBRGH resets the BRG counter.

PIC16(L)F18856/76

TABLE 33-2: SUMMARY OF REGISTERS ASSOCIATED WITH EUSART

Name	Bit 7	Bit 6	Bit 5	Bit 4	Bit 3	Bit 2	Bit 1	Bit 0	Register on Page
INTCON	GIE	PEIE	—	—	—	—	—	INTEDG	134
PIR3	—	—	RCIF	TXIF	BCL2IF	SSP2IF	BCL1IF	SSP1IF	147
PIE3	—	—	RCIE	TXIE	BCL2IE	SSP2IE	BCL1IE	SSP1IE	138
RC1STA	SPEN	RX9	SREN	CREN	ADDEN	FERR	OERR	RX9D	574
TX1STA	CSRC	TX9	TXEN	SYNC	SENDB	BRGH	TRMT	TX9D	573
BAUD1CON	ABDOVF	RCIDL	—	SCKP	BRG16	—	WUE	ABDEN	575
RC1REG	RC1REG<7:0>								558*
TX1REG	TX1REG<7:0>								556*
SPB1RGL	SP1BRG<7:0>								562*
SPB1RGH	SP1BRG<15:8>								562*
RXPPS	—	—	—	RXPPS<4:0>					249
CKPPS	—	—	—	CXPPS<4:0>					249
RxyPPS	—	—	—	RxyPPS<4:0>					250
CLCxSELY	—	—	—	LCxDyS<4:0>					329
MDSRC	—	—	—	MDMS<4:0>					399

Legend: — = unimplemented location, read as '0'. Shaded cells are not used for the EUSART module.

* Page with register information.

PIC16(L)F18856/76

TABLE 33-3: BAUD RATE FORMULAS

Configuration Bits			BRG/EUSART Mode	Baud Rate Formula
SYNC	BRG16	BRGH		
0	0	0	8-bit/Asynchronous	$F_{osc}/[64 (n+1)]$
0	0	1	8-bit/Asynchronous	$F_{osc}/[16 (n+1)]$
0	1	0	16-bit/Asynchronous	
0	1	1	16-bit/Asynchronous	$F_{osc}/[4 (n+1)]$
1	0	x	8-bit/Synchronous	
1	1	x	16-bit/Synchronous	

Legend: x = Don't care, n = value of SPBRGH, SPBRGL register pair.

TABLE 33-4: BAUD RATE FOR ASYNCHRONOUS MODES

BAUD RATE	SYNC = 0, BRGH = 0, BRG16 = 0											
	Fosc = 32.000 MHz			Fosc = 20.000 MHz			Fosc = 18.432 MHz			Fosc = 11.0592 MHz		
	Actual Rate	% Error	SPBRG value (decimal)	Actual Rate	% Error	SPBRG value (decimal)	Actual Rate	% Error	SPBRG value (decimal)	Actual Rate	% Error	SPBRG value (decimal)
300	—	—	—	—	—	—	—	—	—	—	—	—
1200	—	—	—	1221	1.73	255	1200	0.00	239	1200	0.00	143
2400	2404	0.16	207	2404	0.16	129	2400	0.00	119	2400	0.00	71
9600	9615	0.16	51	9470	-1.36	32	9600	0.00	29	9600	0.00	17
10417	10417	0.00	47	10417	0.00	29	10286	-1.26	27	10165	-2.42	16
19.2k	19.23k	0.16	25	19.53k	1.73	15	19.20k	0.00	14	19.20k	0.00	8
57.6k	55.55k	-3.55	3	—	—	—	57.60k	0.00	7	57.60k	0.00	2
115.2k	—	—	—	—	—	—	—	—	—	—	—	—

BAUD RATE	SYNC = 0, BRGH = 0, BRG16 = 0											
	Fosc = 8.000 MHz			Fosc = 4.000 MHz			Fosc = 3.6864 MHz			Fosc = 1.000 MHz		
	Actual Rate	% Error	SPBRG value (decimal)	Actual Rate	% Error	SPBRG value (decimal)	Actual Rate	% Error	SPBRG value (decimal)	Actual Rate	% Error	SPBRG value (decimal)
300	—	—	—	300	0.16	207	300	0.00	191	300	0.16	51
1200	1202	0.16	103	1202	0.16	51	1200	0.00	47	1202	0.16	12
2400	2404	0.16	51	2404	0.16	25	2400	0.00	23	—	—	—
9600	9615	0.16	12	—	—	—	9600	0.00	5	—	—	—
10417	10417	0.00	11	10417	0.00	5	—	—	—	—	—	—
19.2k	—	—	—	—	—	—	19.20k	0.00	2	—	—	—
57.6k	—	—	—	—	—	—	57.60k	0.00	0	—	—	—
115.2k	—	—	—	—	—	—	—	—	—	—	—	—

PIC16(L)F18856/76

TABLE 33-4: BAUD RATE FOR ASYNCHRONOUS MODES (CONTINUED)

BAUD RATE	SYNC = 0, BRGH = 1, BRG16 = 0											
	Fosc = 32.000 MHz			Fosc = 20.000 MHz			Fosc = 18.432 MHz			Fosc = 11.0592 MHz		
	Actual Rate	% Error	SPBRG value (decimal)	Actual Rate	% Error	SPBRG value (decimal)	Actual Rate	% Error	SPBRG value (decimal)	Actual Rate	% Error	SPBRG value (decimal)
300	—	—	—	—	—	—	—	—	—	—	—	—
1200	—	—	—	—	—	—	—	—	—	—	—	—
2400	—	—	—	—	—	—	—	—	—	—	—	—
9600	9615	0.16	207	9615	0.16	129	9600	0.00	119	9600	0.00	71
10417	10417	0.00	191	10417	0.00	119	10378	-0.37	110	10473	0.53	65
19.2k	19.23k	0.16	103	19.23k	0.16	64	19.20k	0.00	59	19.20k	0.00	35
57.6k	57.14k	-0.79	34	56.82k	-1.36	21	57.60k	0.00	19	57.60k	0.00	11
115.2k	117.64k	2.12	16	113.64k	-1.36	10	115.2k	0.00	9	115.2k	0.00	5

BAUD RATE	SYNC = 0, BRGH = 1, BRG16 = 0											
	Fosc = 8.000 MHz			Fosc = 4.000 MHz			Fosc = 3.6864 MHz			Fosc = 1.000 MHz		
	Actual Rate	% Error	SPBRG value (decimal)	Actual Rate	% Error	SPBRG value (decimal)	Actual Rate	% Error	SPBRG value (decimal)	Actual Rate	% Error	SPBRG value (decimal)
300	—	—	—	—	—	—	—	—	—	300	0.16	207
1200	—	—	—	1202	0.16	207	1200	0.00	191	1202	0.16	51
2400	2404	0.16	207	2404	0.16	103	2400	0.00	95	2404	0.16	25
9600	9615	0.16	51	9615	0.16	25	9600	0.00	23	—	—	—
10417	10417	0.00	47	10417	0.00	23	10473	0.53	21	10417	0.00	5
19.2k	19231	0.16	25	19.23k	0.16	12	19.2k	0.00	11	—	—	—
57.6k	55556	-3.55	8	—	—	—	57.60k	0.00	3	—	—	—
115.2k	—	—	—	—	—	—	115.2k	0.00	1	—	—	—

BAUD RATE	SYNC = 0, BRGH = 0, BRG16 = 1											
	Fosc = 32.000 MHz			Fosc = 20.000 MHz			Fosc = 18.432 MHz			Fosc = 11.0592 MHz		
	Actual Rate	% Error	SPBRG value (decimal)	Actual Rate	% Error	SPBRG value (decimal)	Actual Rate	% Error	SPBRG value (decimal)	Actual Rate	% Error	SPBRG value (decimal)
300	300.0	0.00	6666	300.0	-0.01	4166	300.0	0.00	3839	300.0	0.00	2303
1200	1200	-0.02	3332	1200	-0.03	1041	1200	0.00	959	1200	0.00	575
2400	2401	-0.04	832	2399	-0.03	520	2400	0.00	479	2400	0.00	287
9600	9615	0.16	207	9615	0.16	129	9600	0.00	119	9600	0.00	71
10417	10417	0.00	191	10417	0.00	119	10378	-0.37	110	10473	0.53	65
19.2k	19.23k	0.16	103	19.23k	0.16	64	19.20k	0.00	59	19.20k	0.00	35
57.6k	57.14k	-0.79	34	56.818	-1.36	21	57.60k	0.00	19	57.60k	0.00	11
115.2k	117.6k	2.12	16	113.636	-1.36	10	115.2k	0.00	9	115.2k	0.00	5

PIC16(L)F18856/76

TABLE 33-4: BAUD RATE FOR ASYNCHRONOUS MODES (CONTINUED)

BAUD RATE	SYNC = 0, BRGH = 0, BRG16 = 1											
	Fosc = 8.000 MHz			Fosc = 4.000 MHz			Fosc = 3.6864 MHz			Fosc = 1.000 MHz		
	Actual Rate	% Error	SPBRG value (decimal)	Actual Rate	% Error	SPBRG value (decimal)	Actual Rate	% Error	SPBRG value (decimal)	Actual Rate	% Error	SPBRG value (decimal)
300	299.9	-0.02	1666	300.1	0.04	832	300.0	0.00	767	300.5	0.16	207
1200	1199	-0.08	416	1202	0.16	207	1200	0.00	191	1202	0.16	51
2400	2404	0.16	207	2404	0.16	103	2400	0.00	95	2404	0.16	25
9600	9615	0.16	51	9615	0.16	25	9600	0.00	23	—	—	—
10417	10417	0.00	47	10417	0.00	23	10473	0.53	21	10417	0.00	5
19.2k	19.23k	0.16	25	19.23k	0.16	12	19.20k	0.00	11	—	—	—
57.6k	55556	-3.55	8	—	—	—	57.60k	0.00	3	—	—	—
115.2k	—	—	—	—	—	—	115.2k	0.00	1	—	—	—

BAUD RATE	SYNC = 0, BRGH = 1, BRG16 = 1 or SYNC = 1, BRG16 = 1											
	Fosc = 32.000 MHz			Fosc = 20.000 MHz			Fosc = 18.432 MHz			Fosc = 11.0592 MHz		
	Actual Rate	% Error	SPBRG value (decimal)	Actual Rate	% Error	SPBRG value (decimal)	Actual Rate	% Error	SPBRG value (decimal)	Actual Rate	% Error	SPBRG value (decimal)
300	300.0	0.00	26666	300.0	0.00	16665	300.0	0.00	15359	300.0	0.00	9215
1200	1200	0.00	6666	1200	-0.01	4166	1200	0.00	3839	1200	0.00	2303
2400	2400	0.01	3332	2400	0.02	2082	2400	0.00	1919	2400	0.00	1151
9600	9604	0.04	832	9597	-0.03	520	9600	0.00	479	9600	0.00	287
10417	10417	0.00	767	10417	0.00	479	10425	0.08	441	10433	0.16	264
19.2k	19.18k	-0.08	416	19.23k	0.16	259	19.20k	0.00	239	19.20k	0.00	143
57.6k	57.55k	-0.08	138	57.47k	-0.22	86	57.60k	0.00	79	57.60k	0.00	47
115.2k	115.9k	0.64	68	116.3k	0.94	42	115.2k	0.00	39	115.2k	0.00	23

BAUD RATE	SYNC = 0, BRGH = 1, BRG16 = 1 or SYNC = 1, BRG16 = 1											
	Fosc = 8.000 MHz			Fosc = 4.000 MHz			Fosc = 3.6864 MHz			Fosc = 1.000 MHz		
	Actual Rate	% Error	SPBRG value (decimal)	Actual Rate	% Error	SPBRG value (decimal)	Actual Rate	% Error	SPBRG value (decimal)	Actual Rate	% Error	SPBRG value (decimal)
300	300.0	0.00	6666	300.0	0.01	3332	300.0	0.00	3071	300.1	0.04	832
1200	1200	-0.02	1666	1200	0.04	832	1200	0.00	767	1202	0.16	207
2400	2401	0.04	832	2398	0.08	416	2400	0.00	383	2404	0.16	103
9600	9615	0.16	207	9615	0.16	103	9600	0.00	95	9615	0.16	25
10417	10417	0	191	10417	0.00	95	10473	0.53	87	10417	0.00	23
19.2k	19.23k	0.16	103	19.23k	0.16	51	19.20k	0.00	47	19.23k	0.16	12
57.6k	57.14k	-0.79	34	58.82k	2.12	16	57.60k	0.00	15	—	—	—
115.2k	117.6k	2.12	16	111.1k	-3.55	8	115.2k	0.00	7	—	—	—

PIC16(L)F18856/76

34.0 REFERENCE CLOCK OUTPUT MODULE

The Reference Clock Output module provides the ability to send a clock signal to the clock reference output pin (CLKR). The Reference Clock Output can also be used as a signal for other peripherals, such as the Data Signal Modulator (DSM).

The Reference Clock Output module has the following features:

- Selectable input clock
- Programmable clock divider
- Selectable duty cycle

34.1 CLOCK SOURCE

The Reference Clock Output module has a selectable clock source. The CLKRCLK register ([Register 34-2](#)) controls which input is used.

34.1.1 CLOCK SYNCHRONIZATION

Once the reference clock enable (CLKREN) is set, the module is ensured to be glitch-free at start-up.

When the Reference Clock Output is disabled, the output signal will be disabled immediately.

Clock dividers and clock duty cycles can be changed while the module is enabled, but glitches may occur on the output. To avoid possible glitches, clock dividers and clock duty cycles should be changed only when the CLKREN is clear.

34.2 PROGRAMMABLE CLOCK DIVIDER

The module takes the selected clock input and divides it based on the value of the CLKRDIV<2:0> bits of the CLKRCON register ([Register 34-1](#)).

The following configurations can be made based on the CLKRDIV<2:0> bits:

- Base input clock value
- Input clock divided by 2
- Input clock divided by 4
- Input clock divided by 8
- Input clock divided by 16
- Input clock divided by 32
- Input clock divided by 64
- Input clock divided by 128

The clock divider values can be changed while the module is enabled; however, in order to prevent glitches on the output, the CLKRDIV<2:0> bits should only be changed when the module is disabled (CLKREN = 0).

34.3 SELECTABLE DUTY CYCLE

The CLKRDC<1:0> bits of the CLKRCON register can be used to modify the duty cycle of the output clock. A duty cycle of 25%, 50%, or 75% can be selected for all clock rates, with the exception of the undivided base FOSC value.

The duty cycle can be changed while the module is enabled; however, in order to prevent glitches on the output, the CLKRDC<1:0> bits should only be changed when the module is disabled (CLKREN = 0).

Note: The CLKRDC1 bit is reset to '1'. This makes the default duty cycle 50% and not 0%.

34.4 OPERATION IN SLEEP MODE

The Reference Clock Output module is not affected by Sleep mode. The Reference Clock Output module can still operate during Sleep if the clock source selected by CLKRCLK is also active during Sleep.

PIC16(L)F18856/76

FIGURE 34-1: CLOCK REFERENCE BLOCK DIAGRAM

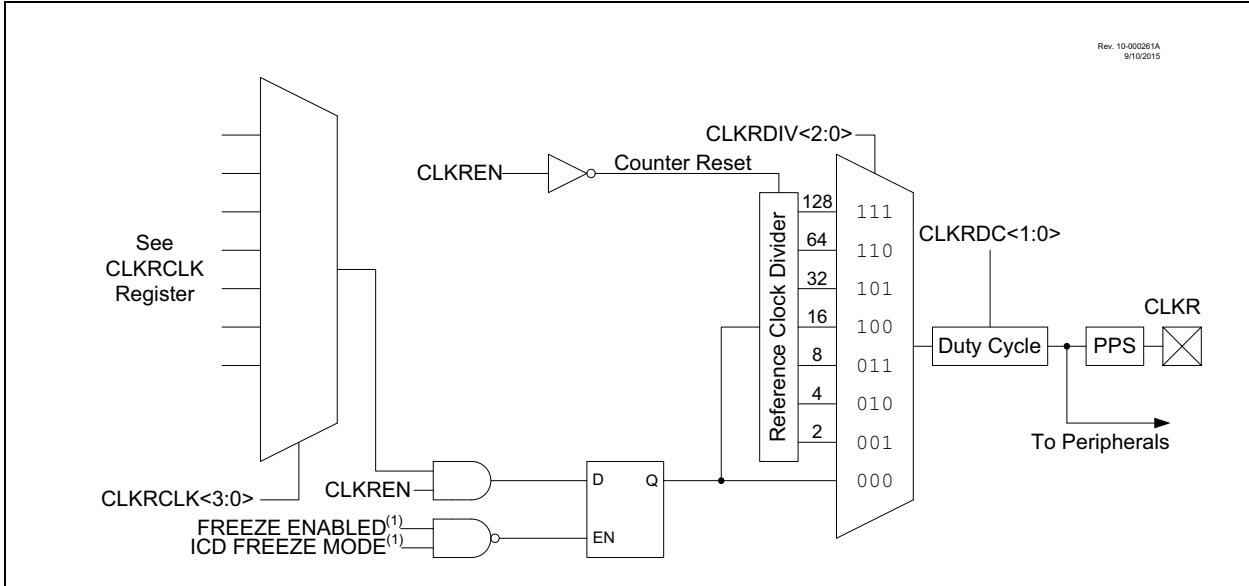
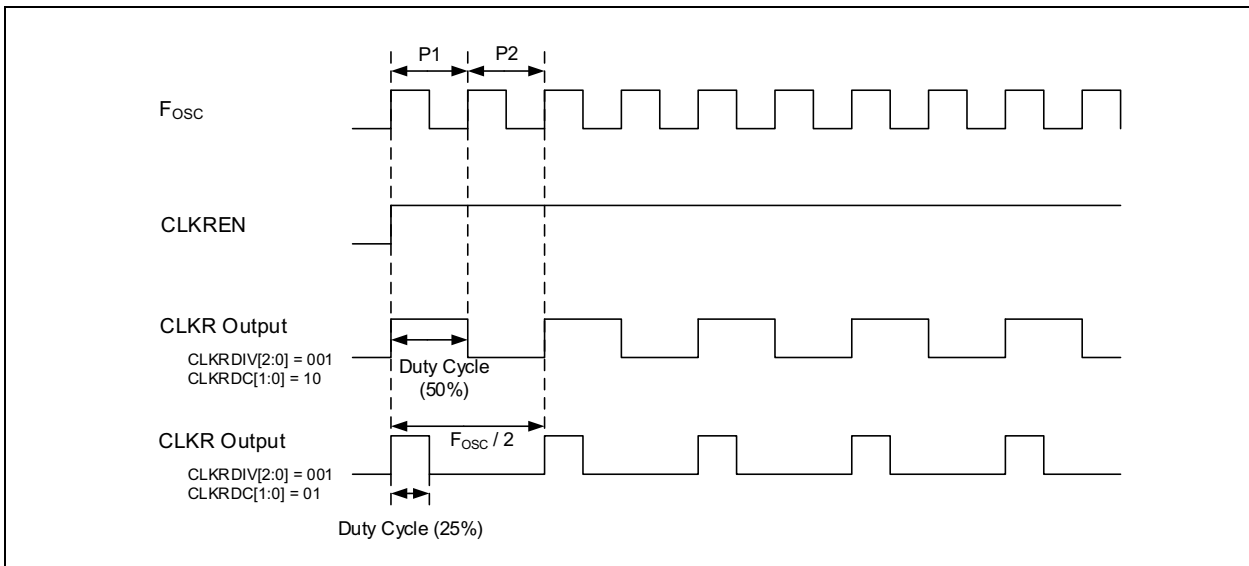

FIGURE 34-2: CLOCK REFERENCE TIMING



PIC16(L)F18856/76

REGISTER 34-1: CLKRCON: REFERENCE CLOCK CONTROL REGISTER

R/W-0/0	U-0	U-0	R/W-0/0	R/W-0/0	R/W-0/0	R/W-0/0	R/W-0/0
CLKREN	—	—	CLKRDC<1:0>		CLKRDIV<2:0>		
bit 7							bit 0

Legend:

R = Readable bit	W = Writable bit	U = Unimplemented bit, read as '0'
u = Bit is unchanged	x = Bit is unknown	-n/n = Value at POR and BOR/Value at all other Resets
'1' = Bit is set	'0' = Bit is cleared	

- bit 7 **CLKREN:** Reference Clock Module Enable bit
 1 = Reference Clock module enabled
 0 = Reference Clock module is disabled
- bit 6-5 **Unimplemented:** Read as '0'
- bit 4-3 **CLKRDC<1:0>:** Reference Clock Duty Cycle bits ⁽¹⁾
 11 = Clock outputs duty cycle of 75%
 10 = Clock outputs duty cycle of 50%
 01 = Clock outputs duty cycle of 25%
 00 = Clock outputs duty cycle of 0%
- bit 2-0 **CLKRDIV<2:0>:** Reference Clock Divider bits
 111 = Input clock divided by 128
 110 = Input clock divided by 64
 101 = Input clock divided by 32
 100 = Input clock divided by 16
 011 = Input clock divided by 8
 010 = Input clock divided by 4
 001 = Input clock divided by 2
 000 = Input clock

Note 1: Bits are valid for Reference Clock divider values of two or larger, the base clock cannot be further divided.

PIC16(L)F18856/76

REGISTER 34-2: CLKRCLK: CLOCK REFERENCE CLOCK SELECTION REGISTER

U-0	U-0	U-0	U-0	R/W-0/0	R/W-0/0	R/W-0/0	R/W-0/0
—	—	—	—	CLKRCLK<3:0>			
bit 7				bit 0			

Legend:
 R = Readable bit W = Writable bit U = Unimplemented bit, read as '0'
 u = Bit is unchanged x = Bit is unknown -n/n = Value at POR and BOR/Value at all other Resets
 '1' = Bit is set '0' = Bit is cleared

bit 7-4 **Unimplemented:** Read as '0'
 bit 3-0 **CLKRCLK<3:0>:** CLKR Input bits
 Clock Selection
 1111 = Reserved
 .
 .
 .
 1010 = Reserved
 1001 = LC4_out
 1000 = LC3_out
 0111 = LC2_out
 0110 = LC1_out
 0101 = NCO output
 0100 = SOSC
 0011 = MFINTOSC
 0010 = LFINTOSC
 0001 = HFINTOSC
 0000 = FOSC

TABLE 34-1: SUMMARY OF REGISTERS ASSOCIATED WITH CLOCK REFERENCE OUTPUT

Name	Bit 7	Bit 6	Bit 5	Bit 4	Bit 3	Bit 2	Bit 1	Bit 0	Register on Page
CLKRCON	CLKREN	—	—	CLKRDC<1:0>		CLKRDIV<2:0>			584
CLKRCLK	—	—	—	—	CLKRCLK<3:0>				585
CLCxSELY	—	—	—	LCxDyS<4:0>					329
MDCARH	—	—	—	—	MDCHS<3:0>				400
MDCARL	—	—	—	—	MDCLS<3:0>				401
RxyPPS	—	—	—	RxyPPS<4:0>					250

Legend: — = unimplemented, read as '0'. Shaded cells are not used by the CLKR module.

PIC16(L)F18856/76

35.0 IN-CIRCUIT SERIAL PROGRAMMING™ (ICSP™)

ICSP™ programming allows customers to manufacture circuit boards with unprogrammed devices. Programming can be done after the assembly process, allowing the device to be programmed with the most recent firmware or a custom firmware. Five pins are needed for ICSP™ programming:

- ICSPCLK
- ICSPDAT
- MCLR/VPP
- VDD
- VSS

In Program/Verify mode the program memory, User IDs and the Configuration Words are programmed through serial communications. The ICSPDAT pin is a bidirectional I/O used for transferring the serial data and the ICSPCLK pin is the clock input. For more information on ICSP™ refer to the “PIC16(L)F1783XX Memory Programming Specification” (DS400001738).

35.1 High-Voltage Programming Entry Mode

The device is placed into High-Voltage Programming Entry mode by holding the ICSPCLK and ICSPDAT pins low then raising the voltage on MCLR/VPP to VIH.

35.2 Low-Voltage Programming Entry Mode

The Low-Voltage Programming Entry mode allows the PIC® Flash MCUs to be programmed using VDD only, without high voltage. When the LVP bit of Configuration Words is set to ‘1’, the low-voltage ICSP programming entry is enabled. To disable the Low-Voltage ICSP mode, the LVP bit must be programmed to ‘0’.

Entry into the Low-Voltage Programming Entry mode requires the following steps:

1. $\overline{\text{MCLR}}$ is brought to VIL.
2. A 32-bit key sequence is presented on ICSPDAT, while clocking ICSPCLK.

Once the key sequence is complete, $\overline{\text{MCLR}}$ must be held at VIL for as long as Program/Verify mode is to be maintained.

If low-voltage programming is enabled (LVP = 1), the MCLR Reset function is automatically enabled and cannot be disabled. See [Section 5.4 “MCLR”](#) for more information.

The LVP bit can only be reprogrammed to ‘0’ by using the High-Voltage Programming mode.

35.3 Common Programming Interfaces

Connection to a target device is typically done through an ICSP™ header. A commonly found connector on development tools is the RJ-11 in the 6P6C (6-pin, 6-connector) configuration. See [Figure 35-1](#).

FIGURE 35-1: ICD RJ-11 STYLE CONNECTOR INTERFACE

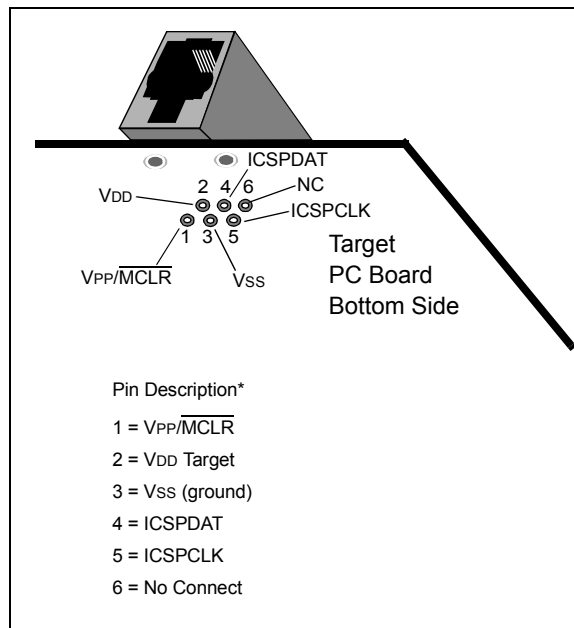

Another connector often found in use with the PICkit™ programmers is a standard 6-pin header with 0.1 inch spacing. Refer to [Figure 35-2](#).

For additional interface recommendations, refer to your specific device programmer manual prior to PCB design.

It is recommended that isolation devices be used to separate the programming pins from other circuitry. The type of isolation is highly dependent on the specific application and may include devices such as resistors, diodes, or even jumpers. See [Figure 35-3](#) for more information.

PIC16(L)F18856/76

FIGURE 35-2: PICKIT™ PROGRAMMER STYLE CONNECTOR INTERFACE

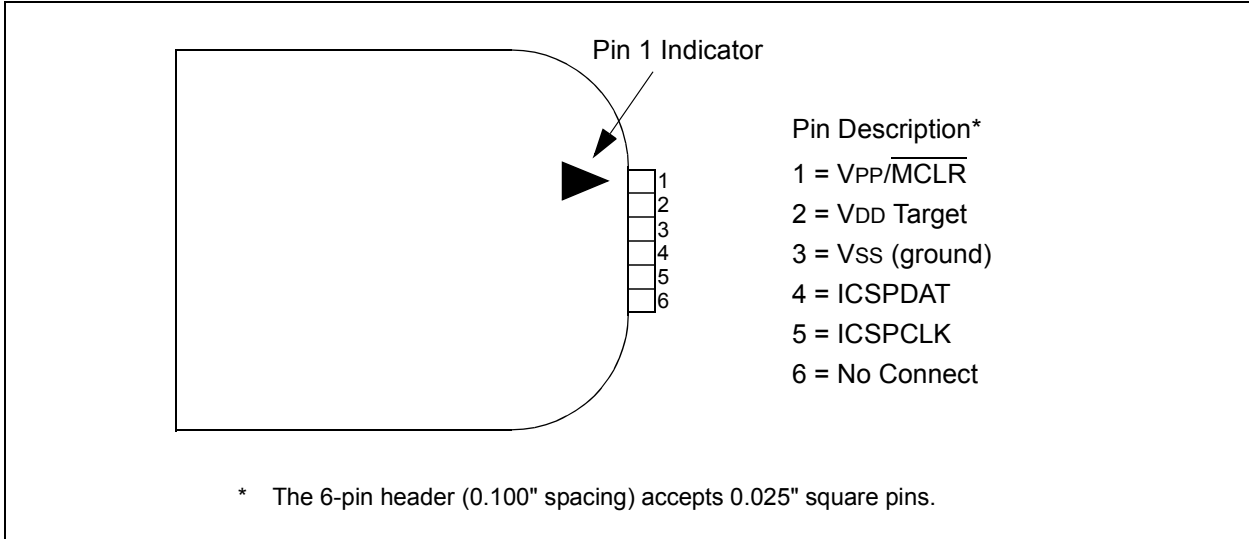
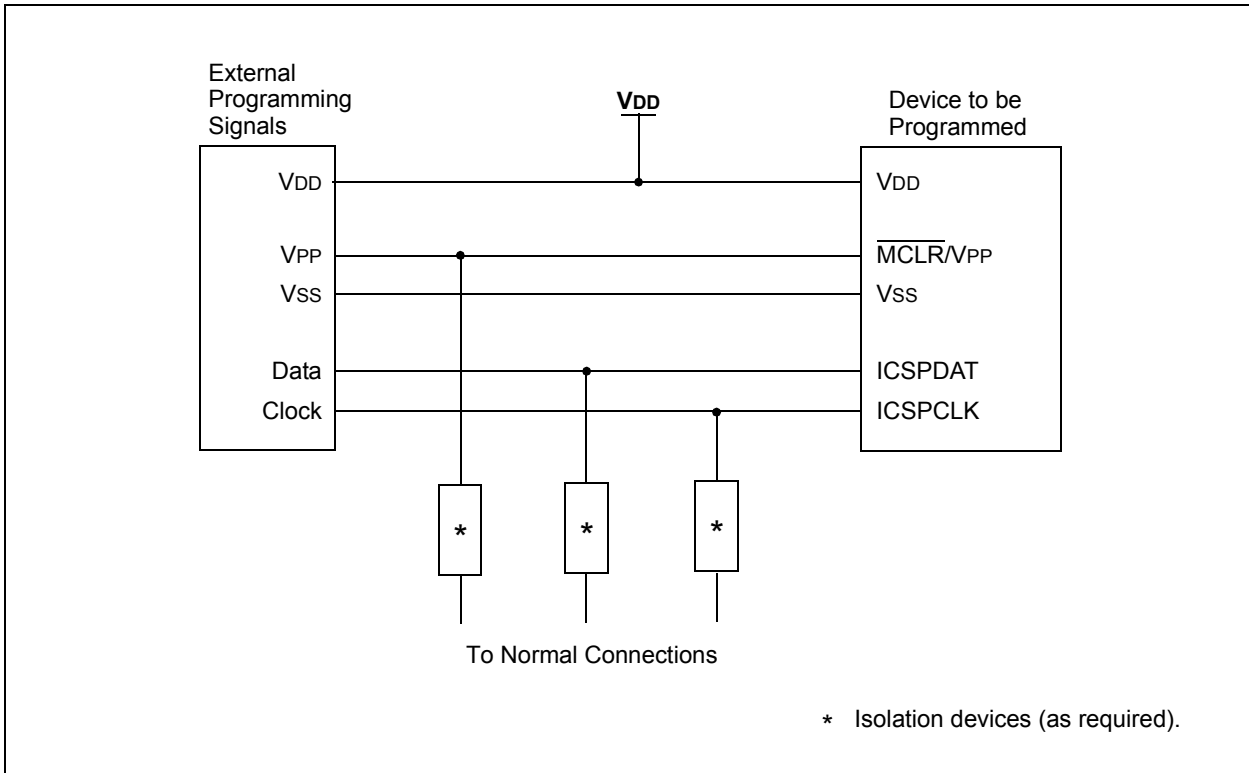

FIGURE 35-3: TYPICAL CONNECTION FOR ICSP™ PROGRAMMING



PIC16(L)F18856/76

36.0 INSTRUCTION SET SUMMARY

Each instruction is a 14-bit word containing the operation code (opcode) and all required operands. The opcodes are broken into three broad categories.

- Byte Oriented
- Bit Oriented
- Literal and Control

The literal and control category contains the most varied instruction word format.

Table 36-4 lists the instructions recognized by the MPASM™ assembler.

All instructions are executed within a single instruction cycle, with the following exceptions, which may take two or three cycles:

- Subroutine takes two cycles (CALL, CALLW)
- Returns from interrupts or subroutines take two cycles (RETURN, RETLW, RETFIE)
- Program branching takes two cycles (GOTO, BRA, BRW, BTFSS, BTFSC, DECFSZ, INCSFZ)
- One additional instruction cycle will be used when any instruction references an indirect file register and the file select register is pointing to program memory.

One instruction cycle consists of 4 oscillator cycles; for an oscillator frequency of 4 MHz, this gives a nominal instruction execution rate of 1 MHz.

All instruction examples use the format '0xhh' to represent a hexadecimal number, where 'h' signifies a hexadecimal digit.

36.1 Read-Modify-Write Operations

Any instruction that specifies a file register as part of the instruction performs a Read-Modify-Write (R-M-W) operation. The register is read, the data is modified, and the result is stored according to either the instruction, or the destination designator 'd'. A read operation is performed on a register even if the instruction writes to that register.

TABLE 36-1: OPCODE FIELD DESCRIPTIONS

Field	Description
f	Register file address (0x00 to 0x7F)
W	Working register (accumulator)
b	Bit address within an 8-bit file register
k	Literal field, constant data or label
x	Don't care location (= 0 or 1). The assembler will generate code with x = 0. It is the recommended form of use for compatibility with all Microchip software tools.
d	Destination select; d = 0: store result in W, d = 1: store result in file register f. Default is d = 1.
n	FSR or INDF number. (0-1)
mm	Prepost increment-decrement mode selection

TABLE 36-2: ABBREVIATION DESCRIPTIONS

Field	Description
PC	Program Counter
\overline{TO}	Time-Out bit
C	Carry bit
DC	Digit Carry bit
Z	Zero bit
\overline{PD}	Power-Down bit

PIC16(L)F18856/76

TABLE 36-3: GENERAL FORMAT FOR INSTRUCTIONS

Byte-oriented file register operations						
13	8	7	6	0		
OPCODE		d	f (FILE #)			
d = 0 for destination W d = 1 for destination f f = 7-bit file register address						
Bit-oriented file register operations						
13	10	9	7	6	0	
OPCODE		b (BIT #)		f (FILE #)		
b = 3-bit bit address f = 7-bit file register address						
Literal and control operations						
General						
13	8	7				0
OPCODE			k (literal)			
k = 8-bit immediate value						
CALL and GOTO instructions only						
13	11	10				0
OPCODE		k (literal)				
k = 11-bit immediate value						
MOVLW instruction only						
13	7	6				0
OPCODE			k (literal)			
k = 7-bit immediate value						
MOVLB instruction only						
13	5	4				0
OPCODE			k (literal)			
k = 5-bit immediate value						
BRA instruction only						
13	9	8				0
OPCODE			k (literal)			
k = 9-bit immediate value						
FSR Offset instructions						
13	7	6	5			0
OPCODE		n	k (literal)			
n = appropriate FSR k = 6-bit immediate value						
FSR Increment instructions						
13	3	2	1			0
OPCODE			n	m (mode)		
n = appropriate FSR m = 2-bit mode value						
OPCODE only						
13					0	
OPCODE						

PIC16(L)F18856/76

TABLE 36-4: INSTRUCTION SET

Mnemonic, Operands	Description	Cycles	14-Bit Opcode				Status Affected	Notes	
			MSb	LSb					
BYTE-ORIENTED FILE REGISTER OPERATIONS									
ADDWF	f, d	Add W and f	1	00	0111	dfff	ffff	C, DC, Z	2
ADDWFC	f, d	Add with Carry W and f	1	11	1101	dfff	ffff	C, DC, Z	2
ANDWF	f, d	AND W with f	1	00	0101	dfff	ffff	Z	2
ASRF	f, d	Arithmetic Right Shift	1	11	0111	dfff	ffff	C, Z	2
LSLF	f, d	Logical Left Shift	1	11	0101	dfff	ffff	C, Z	2
LSRF	f, d	Logical Right Shift	1	11	0110	dfff	ffff	C, Z	2
CLRF	f	Clear f	1	00	0001	1fff	ffff	Z	2
CLRW	–	Clear W	1	00	0001	0000	00xx	Z	
COMF	f, d	Complement f	1	00	1001	dfff	ffff	Z	2
DECf	f, d	Decrement f	1	00	0011	dfff	ffff	Z	2
INCF	f, d	Increment f	1	00	1010	dfff	ffff	Z	2
IORWF	f, d	Inclusive OR W with f	1	00	0100	dfff	ffff	Z	2
MOVF	f, d	Move f	1	00	1000	dfff	ffff	Z	2
MOVWF	f	Move W to f	1	00	0000	1fff	ffff		2
RLF	f, d	Rotate Left f through Carry	1	00	1101	dfff	ffff	C	2
RRF	f, d	Rotate Right f through Carry	1	00	1100	dfff	ffff	C	2
SUBWF	f, d	Subtract W from f	1	00	0010	dfff	ffff	C, DC, Z	2
SUBWFB	f, d	Subtract with Borrow W from f	1	11	1011	dfff	ffff	C, DC, Z	2
SWAPF	f, d	Swap nibbles in f	1	00	1110	dfff	ffff		2
XORWF	f, d	Exclusive OR W with f	1	00	0110	dfff	ffff	Z	2
BYTE ORIENTED SKIP OPERATIONS									
DECFSZ	f, d	Decrement f, Skip if 0	1(2)	00	1011	dfff	ffff		1, 2
INCFSZ	f, d	Increment f, Skip if 0	1(2)	00	1111	dfff	ffff		1, 2
BIT-ORIENTED FILE REGISTER OPERATIONS									
BCF	f, b	Bit Clear f	1	01	00bb	bfff	ffff		2
BSF	f, b	Bit Set f	1	01	01bb	bfff	ffff		2
BIT-ORIENTED SKIP OPERATIONS									
BTFSC	f, b	Bit Test f, Skip if Clear	1 (2)	01	10bb	bfff	ffff		1, 2
BTFSS	f, b	Bit Test f, Skip if Set	1 (2)	01	11bb	bfff	ffff		1, 2
LITERAL OPERATIONS									
ADDLW	k	Add literal and W	1	11	1110	kkkk	kkkk	C, DC, Z	
ANDLW	k	AND literal with W	1	11	1001	kkkk	kkkk	Z	
IORLW	k	Inclusive OR literal with W	1	11	1000	kkkk	kkkk	Z	
MOVLB	k	Move literal to BSR	1	00	0000	001k	kkkk		
MOVLP	k	Move literal to PCLATH	1	11	0001	1kkk	kkkk		
MOVLW	k	Move literal to W	1	11	0000	kkkk	kkkk		
SUBLW	k	Subtract W from literal	1	11	1100	kkkk	kkkk	C, DC, Z	
XORLW	k	Exclusive OR literal with W	1	11	1010	kkkk	kkkk	Z	

- Note 1:** If the Program Counter (PC) is modified, or a conditional test is true, the instruction requires two cycles. The second cycle is executed as a NOP.
- Note 2:** If this instruction addresses an INDF register and the MSb of the corresponding FSR is set, this instruction will require one additional instruction cycle.

PIC16(L)F18856/76

TABLE 36-4: INSTRUCTION SET (CONTINUED)

Mnemonic, Operands	Description	Cycles	14-Bit Opcode				Status Affected	Notes
			MSb			LSb		
CONTROL OPERATIONS								
BRA	k	Relative Branch	2	11	001k	kkkk	kkkk	
BRW	–	Relative Branch with W	2	00	0000	0000	1011	
CALL	k	Call Subroutine	2	10	0kkk	kkkk	kkkk	
CALLW	–	Call Subroutine with W	2	00	0000	0000	1010	
GOTO	k	Go to address	2	10	1kkk	kkkk	kkkk	
RETFIE	k	Return from interrupt	2	00	0000	0000	1001	
RETLW	k	Return with literal in W	2	11	0100	kkkk	kkkk	
RETURN	–	Return from Subroutine	2	00	0000	0000	1000	
INHERENT OPERATIONS								
CLRWDT	–	Clear Watchdog Timer	1	00	0000	0110	0100	$\overline{TO}, \overline{PD}$
NOP	–	No Operation	1	00	0000	0000	0000	
RESET	–	Software device Reset	1	00	0000	0000	0001	
SLEEP	–	Go into Standby or IDLE mode	1	00	0000	0110	0011	$\overline{TO}, \overline{PD}$
TRIS	f	Load TRIS register with W	1	00	0000	0110	0fff	
C-COMPILER OPTIMIZED								
ADDFSR	n, k	Add Literal k to FSRn	1	11	0001	0nkk	kkkk	
MOVIW	n mm	Move Indirect FSRn to W with pre/post inc/dec modifier, mm	1	00	0000	0001	0nmm	Z
	k[n]	Move INDFn to W, Indexed Indirect.	1	11	1111	0nkk	kkkk	Z
MOVWI	n mm	Move W to Indirect FSRn with pre/post inc/dec modifier, mm	1	00	0000	0001	1nmm	
	k[n]	Move W to INDFn, Indexed Indirect.	1	11	1111	1nkk	kkkk	

- Note 1:** If the Program Counter (PC) is modified, or a conditional test is true, the instruction requires two cycles. The second cycle is executed as a *NOP*.
- 2:** If this instruction addresses an INDF register and the MSb of the corresponding FSR is set, this instruction will require one additional instruction cycle.
- 3:** See Table in the MOVIW and MOVWI instruction descriptions.

PIC16(L)F18856/76

36.2 Instruction Descriptions

ADDFSR	Add Literal to FSRn
Syntax:	[<i>label</i>] ADDFSR FSRn, k
Operands:	-32 ≤ k ≤ 31 n ∈ [0, 1]
Operation:	FSR(n) + k → FSR(n)
Status Affected:	None
Description:	The signed 6-bit literal 'k' is added to the contents of the FSRnH:FSRnL register pair. FSRn is limited to the range 0000h-FFFFh. Moving beyond these bounds will cause the FSR to wrap-around.

ADDLW	Add literal and W
Syntax:	[<i>label</i>] ADDLW k
Operands:	0 ≤ k ≤ 255
Operation:	(W) + k → (W)
Status Affected:	C, DC, Z
Description:	The contents of the W register are added to the 8-bit literal 'k' and the result is placed in the W register.

ADDWF	Add W and f
Syntax:	[<i>label</i>] ADDWF f,d
Operands:	0 ≤ f ≤ 127 d ∈ [0,1]
Operation:	(W) + (f) → (destination)
Status Affected:	C, DC, Z
Description:	Add the contents of the W register with register 'f'. If 'd' is '0', the result is stored in the W register. If 'd' is '1', the result is stored back in register 'f'.

ADDWFC	ADD W and CARRY bit to f
Syntax:	[<i>label</i>] ADDWFC f {,d}
Operands:	0 ≤ f ≤ 127 d ∈ [0,1]
Operation:	(W) + (f) + (C) → dest
Status Affected:	C, DC, Z
Description:	Add W, the Carry flag and data memory location 'f'. If 'd' is '0', the result is placed in W. If 'd' is '1', the result is placed in data memory location 'f'.

ANDLW	AND literal with W
Syntax:	[<i>label</i>] ANDLW k
Operands:	0 ≤ k ≤ 255
Operation:	(W) .AND. (k) → (W)
Status Affected:	Z
Description:	The contents of W register are AND'ed with the 8-bit literal 'k'. The result is placed in the W register.

ANDWF	AND W with f
Syntax:	[<i>label</i>] ANDWF f,d
Operands:	0 ≤ f ≤ 127 d ∈ [0,1]
Operation:	(W) .AND. (f) → (destination)
Status Affected:	Z
Description:	AND the W register with register 'f'. If 'd' is '0', the result is stored in the W register. If 'd' is '1', the result is stored back in register 'f'.

ASRF	Arithmetic Right Shift
Syntax:	[<i>label</i>] ASRF f {,d}
Operands:	0 ≤ f ≤ 127 d ∈ [0,1]
Operation:	(f<7>) → dest<7> (f<7:1>) → dest<6:0>, (f<0>) → C,
Status Affected:	C, Z
Description:	The contents of register 'f' are shifted one bit to the right through the Carry flag. The MSb remains unchanged. If 'd' is '0', the result is placed in W. If 'd' is '1', the result is stored back in register 'f'.

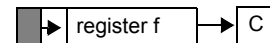

PIC16(L)F18856/76

BCF	Bit Clear f
Syntax:	[<i>label</i>] BCF f,b
Operands:	$0 \leq f \leq 127$ $0 \leq b \leq 7$
Operation:	$0 \rightarrow (f)$
Status Affected:	None
Description:	Bit 'b' in register 'f' is cleared.

BTFSC	Bit Test f, Skip if Clear
Syntax:	[<i>label</i>] BTFSC f,b
Operands:	$0 \leq f \leq 127$ $0 \leq b \leq 7$
Operation:	skip if (f) = 0
Status Affected:	None
Description:	If bit 'b' in register 'f' is '1', the next instruction is executed. If bit 'b', in register 'f', is '0', the next instruction is discarded, and a NOP is executed instead, making this a 2-cycle instruction.

BRA	Relative Branch
Syntax:	[<i>label</i>] BRA label [<i>label</i>] BRA \$+k
Operands:	$-256 \leq \text{label} - \text{PC} + 1 \leq 255$ $-256 \leq k \leq 255$
Operation:	$(\text{PC}) + 1 + k \rightarrow \text{PC}$
Status Affected:	None
Description:	Add the signed 9-bit literal 'k' to the PC. Since the PC will have incremented to fetch the next instruction, the new address will be $\text{PC} + 1 + k$. This instruction is a 2-cycle instruction. This branch has a limited range.

BTFSS	Bit Test f, Skip if Set
Syntax:	[<i>label</i>] BTFSS f,b
Operands:	$0 \leq f \leq 127$ $0 \leq b < 7$
Operation:	skip if (f) = 1
Status Affected:	None
Description:	If bit 'b' in register 'f' is '0', the next instruction is executed. If bit 'b' is '1', then the next instruction is discarded and a NOP is executed instead, making this a 2-cycle instruction.

BRW	Relative Branch with W
Syntax:	[<i>label</i>] BRW
Operands:	None
Operation:	$(\text{PC}) + (W) \rightarrow \text{PC}$
Status Affected:	None
Description:	Add the contents of W (unsigned) to the PC. Since the PC will have incremented to fetch the next instruction, the new address will be $\text{PC} + 1 + (W)$. This instruction is a 2-cycle instruction.

BSF	Bit Set f
Syntax:	[<i>label</i>] BSF f,b
Operands:	$0 \leq f \leq 127$ $0 \leq b \leq 7$
Operation:	$1 \rightarrow (f)$
Status Affected:	None
Description:	Bit 'b' in register 'f' is set.

PIC16(L)F18856/76

CALL Call Subroutine

Syntax:	[<i>label</i>] CALL k
Operands:	$0 \leq k \leq 2047$
Operation:	(PC)+1 → TOS, k → PC<10:0>, (PCLATH<6:3>) → PC<14:11>
Status Affected:	None
Description:	Call Subroutine. First, return address (PC + 1) is pushed onto the stack. The 11-bit immediate address is loaded into PC bits <10:0>. The upper bits of the PC are loaded from PCLATH. CALL is a 2-cycle instruction.

CLRWDT Clear Watchdog Timer

Syntax:	[<i>label</i>] CLRWDT
Operands:	None
Operation:	00h → WDT 0 → WDT prescaler, 1 → \overline{TO} 1 → \overline{PD}
Status Affected:	\overline{TO} , \overline{PD}
Description:	CLRWDT instruction resets the Watchdog Timer. It also resets the prescaler of the WDT. Status bits \overline{TO} and \overline{PD} are set.

CALLW Subroutine Call With W

Syntax:	[<i>label</i>] CALLW
Operands:	None
Operation:	(PC) + 1 → TOS, (W) → PC<7:0>, (PCLATH<6:0>) → PC<14:8>
Status Affected:	None
Description:	Subroutine call with W. First, the return address (PC + 1) is pushed onto the return stack. Then, the contents of W is loaded into PC<7:0>, and the contents of PCLATH into PC<14:8>. CALLW is a 2-cycle instruction.

COMF Complement f

Syntax:	[<i>label</i>] COMF f,d
Operands:	$0 \leq f \leq 127$ d ∈ [0,1]
Operation:	(\bar{f}) → (destination)
Status Affected:	Z
Description:	The contents of register 'f' are complemented. If 'd' is '0', the result is stored in W. If 'd' is '1', the result is stored back in register 'f'.

CLRF Clear f

Syntax:	[<i>label</i>] CLRF f
Operands:	$0 \leq f \leq 127$
Operation:	00h → (f) 1 → Z
Status Affected:	Z
Description:	The contents of register 'f' are cleared and the Z bit is set.

DECF Decrement f

Syntax:	[<i>label</i>] DECF f,d
Operands:	$0 \leq f \leq 127$ d ∈ [0,1]
Operation:	(f) - 1 → (destination)
Status Affected:	Z
Description:	Decrement register 'f'. If 'd' is '0', the result is stored in the W register. If 'd' is '1', the result is stored back in register 'f'.

CLRW Clear W

Syntax:	[<i>label</i>] CLRW
Operands:	None
Operation:	00h → (W) 1 → Z
Status Affected:	Z
Description:	W register is cleared. Zero bit (Z) is set.

PIC16(L)F18856/76

DECFSZ **Decrement f, Skip if 0**

Syntax: [*label*] DECFSZ f,d

Operands: $0 \leq f \leq 127$
 $d \in [0,1]$

Operation: $(f) - 1 \rightarrow (\text{destination})$;
 skip if result = 0

Status Affected: None

Description: The contents of register 'f' are decremented. If 'd' is '0', the result is placed in the W register. If 'd' is '1', the result is placed back in register 'f'. If the result is '1', the next instruction is executed. If the result is '0', then a NOP is executed instead, making it a 2-cycle instruction.

INCFSZ **Increment f, Skip if 0**

Syntax: [*label*] INCFSZ f,d

Operands: $0 \leq f \leq 127$
 $d \in [0,1]$

Operation: $(f) + 1 \rightarrow (\text{destination})$;
 skip if result = 0

Status Affected: None

Description: The contents of register 'f' are incremented. If 'd' is '0', the result is placed in the W register. If 'd' is '1', the result is placed back in register 'f'. If the result is '1', the next instruction is executed. If the result is '0', a NOP is executed instead, making it a 2-cycle instruction.

GOTO **Unconditional Branch**

Syntax: [*label*] GOTO k

Operands: $0 \leq k \leq 2047$

Operation: $k \rightarrow \text{PC}<10:0>$
 $\text{PCLATH}<6:3> \rightarrow \text{PC}<14:11>$

Status Affected: None

Description: GOTO is an unconditional branch. The 11-bit immediate value is loaded into PC bits <10:0>. The upper bits of PC are loaded from PCLATH<4:3>. GOTO is a 2-cycle instruction.

IORLW **Inclusive OR literal with W**

Syntax: [*label*] IORLW k

Operands: $0 \leq k \leq 255$

Operation: $(W) .\text{OR. } k \rightarrow (W)$

Status Affected: Z

Description: The contents of the W register are OR'ed with the 8-bit literal 'k'. The result is placed in the W register.

INCF **Increment f**

Syntax: [*label*] INCF f,d

Operands: $0 \leq f \leq 127$
 $d \in [0,1]$

Operation: $(f) + 1 \rightarrow (\text{destination})$

Status Affected: Z

Description: The contents of register 'f' are incremented. If 'd' is '0', the result is placed in the W register. If 'd' is '1', the result is placed back in register 'f'.

IORWF **Inclusive OR W with f**

Syntax: [*label*] IORWF f,d

Operands: $0 \leq f \leq 127$
 $d \in [0,1]$

Operation: $(W) .\text{OR. } (f) \rightarrow (\text{destination})$

Status Affected: Z

Description: Inclusive OR the W register with register 'f'. If 'd' is '0', the result is placed in the W register. If 'd' is '1', the result is placed back in register 'f'.

PIC16(L)F18856/76

LSLF Logical Left Shift

Syntax: `[label] LSLF f {,d}`

Operands: $0 \leq f \leq 127$
 $d \in [0,1]$

Operation: $(f<7>) \rightarrow C$
 $(f<6:0>) \rightarrow \text{dest}<7:1>$
 $0 \rightarrow \text{dest}<0>$

Status Affected: C, Z

Description: The contents of register 'f' are shifted one bit to the left through the Carry flag. A '0' is shifted into the LSb. If 'd' is '0', the result is placed in W. If 'd' is '1', the result is stored back in register 'f'.

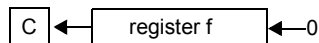

LSRF Logical Right Shift

Syntax: `[label] LSRF f {,d}`

Operands: $0 \leq f \leq 127$
 $d \in [0,1]$

Operation: $0 \rightarrow \text{dest}<7>$
 $(f<7:1>) \rightarrow \text{dest}<6:0>$,
 $(f<0>) \rightarrow C$,

Status Affected: C, Z

Description: The contents of register 'f' are shifted one bit to the right through the Carry flag. A '0' is shifted into the MSb. If 'd' is '0', the result is placed in W. If 'd' is '1', the result is stored back in register 'f'.

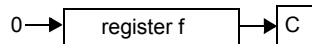

MOVF Move f

Syntax: `[label] MOVF f,d`

Operands: $0 \leq f \leq 127$
 $d \in [0,1]$

Operation: $(f) \rightarrow (\text{dest})$

Status Affected: Z

Description: The contents of register f is moved to a destination dependent upon the status of d. If d = 0, destination is W register. If d = 1, the destination is file register f itself. d = 1 is useful to test a file register since status flag Z is affected.

Words: 1

Cycles: 1

Example: `MOVF FSR, 0`

After Instruction

W = value in FSR register

Z = 1

PIC16(L)F18856/76

MOVIW Move INDFn to W

Syntax: [*label*] MOVIW ++FSRn
 [*label*] MOVIW --FSRn
 [*label*] MOVIW FSRn++
 [*label*] MOVIW FSRn--
 [*label*] MOVIW k[FSRn]

Operands: $n \in [0,1]$
 $mm \in [00,01, 10, 11]$
 $-32 \leq k \leq 31$

Operation: INDFn \rightarrow W
 Effective address is determined by

- FSR + 1 (preincrement)
- FSR - 1 (predecrement)
- FSR + k (relative offset)

After the Move, the FSR value will be either:

- FSR + 1 (all increments)
- FSR - 1 (all decrements)
- Unchanged

Status Affected: Z

Mode	Syntax	mm
Preincrement	++FSRn	00
Predecrement	--FSRn	01
Postincrement	FSRn++	10
Postdecrement	FSRn--	11

Description: This instruction is used to move data between W and one of the indirect registers (INDFn). Before/after this move, the pointer (FSRn) is updated by pre/post incrementing/decrementing it.

Note: The INDFn registers are not physical registers. Any instruction that accesses an INDFn register actually accesses the register at the address specified by the FSRn.

FSRn is limited to the range 0000h - FFFFh. Incrementing/decrementing it beyond these bounds will cause it to wrap-around.

MOVLB Move literal to BSR

Syntax: [*label*] MOVLB k

Operands: $0 \leq k \leq 31$

Operation: $k \rightarrow$ BSR

Status Affected: None

Description: The 5-bit literal 'k' is loaded into the Bank Select Register (BSR).

MOVLP Move literal to PCLATH

Syntax: [*label*] MOVLP k

Operands: $0 \leq k \leq 127$

Operation: $k \rightarrow$ PCLATH

Status Affected: None

Description: The 7-bit literal 'k' is loaded into the PCLATH register.

MOVLW Move literal to W

Syntax: [*label*] MOVLW k

Operands: $0 \leq k \leq 255$

Operation: $k \rightarrow$ (W)

Status Affected: None

Description: The 8-bit literal 'k' is loaded into W register. The "don't cares" will assemble as '0's.

Words: 1

Cycles: 1

Example: MOVLW 0x5A
 After Instruction
 W = 0x5A

MOVWF Move W to f

Syntax: [*label*] MOVWF f

Operands: $0 \leq f \leq 127$

Operation: (W) \rightarrow (f)

Status Affected: None

Description: Move data from W register to register 'f'.

Words: 1

Cycles: 1

Example: MOVWF LATA
 Before Instruction
 LATA = 0xFF
 W = 0x4F
 After Instruction
 LATA = 0x4F
 W = 0x4F

PIC16(L)F18856/76

MOVWI	Move W to INDFn
Syntax:	[<i>label</i>] MOVWI ++FSRn [<i>label</i>] MOVWI --FSRn [<i>label</i>] MOVWI FSRn++ [<i>label</i>] MOVWI FSRn-- [<i>label</i>] MOVWI k[FSRn]
Operands:	n ∈ [0,1] mm ∈ [00,01, 10, 11] -32 ≤ k ≤ 31
Operation:	W → INDFn Effective address is determined by <ul style="list-style-type: none"> • FSR + 1 (preincrement) • FSR - 1 (predecrement) • FSR + k (relative offset) After the Move, the FSR value will be either: <ul style="list-style-type: none"> • FSR + 1 (all increments) • FSR - 1 (all decrements) Unchanged
Status Affected:	None

Mode	Syntax	mm
Preincrement	++FSRn	00
Predecrement	--FSRn	01
Postincrement	FSRn++	10
Postdecrement	FSRn--	11

Description: This instruction is used to move data between W and one of the indirect registers (INDFn). Before/after this move, the pointer (FSRn) is updated by pre/post incrementing/decrementing it.

Note: The INDFn registers are not physical registers. Any instruction that accesses an INDFn register actually accesses the register at the address specified by the FSRn.

FSRn is limited to the range 0000h-FFFFh. Incrementing/decrementing it beyond these bounds will cause it to wrap-around.

The increment/decrement operation on FSRn WILL NOT affect any Status bits.

NOP	No Operation
Syntax:	[<i>label</i>] NOP
Operands:	None
Operation:	No operation
Status Affected:	None
Description:	No operation.
Words:	1
Cycles:	1
<u>Example:</u>	NOP

RESET	Software Reset
Syntax:	[<i>label</i>] RESET
Operands:	None
Operation:	Execute a device Reset. Resets the RI flag of the PCON register.
Status Affected:	None
Description:	This instruction provides a way to execute a hardware Reset by software.

RETFIE	Return from Interrupt
Syntax:	[<i>label</i>] RETFIE k
Operands:	None
Operation:	TOS → PC, 1 → GIE
Status Affected:	None
Description:	Return from Interrupt. Stack is POPed and Top-of-Stack (TOS) is loaded in the PC. Interrupts are enabled by setting Global Interrupt Enable bit, GIE (INTCON<7>). This is a 2-cycle instruction.
Words:	1
Cycles:	2
<u>Example:</u>	RETFIE
	After Interrupt
	PC = TOS
	GIE = 1

PIC16(L)F18856/76

RETLW **Return with literal in W**

Syntax: `[label] RETLW k`

Operands: $0 \leq k \leq 255$

Operation: $k \rightarrow (W)$;
 $TOS \rightarrow PC$

Status Affected: None

Description: The W register is loaded with the 8-bit literal 'k'. The program counter is loaded from the top of the stack (the return address). This is a 2-cycle instruction.

Words: 1

Cycles: 2

Example: `CALL TABLE;W contains table`
 `;offset value`

- `;W now has table value`
-
-

`ADDWF PC ;W = offset`
`RETLW k1 ;Begin table`
`RETLW k2 ;`

-
-
-

`RETLW kn ; End of table`

Before Instruction
 W = 0x07

After Instruction
 W = value of k8

RETURN **Return from Subroutine**

Syntax: `[label] RETURN`

Operands: None

Operation: $TOS \rightarrow PC$

Status Affected: None

Description: Return from subroutine. The stack is POPed and the top of the stack (TOS) is loaded into the program counter. This is a 2-cycle instruction.

RLF **Rotate Left f through Carry**

Syntax: `[label] RLF f,d`

Operands: $0 \leq f \leq 127$
 $d \in [0,1]$

Operation: See description below

Status Affected: C

Description: The contents of register 'f' are rotated one bit to the left through the Carry flag. If 'd' is '0', the result is placed in the W register. If 'd' is '1', the result is stored back in register 'f'.

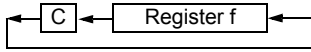

Words: 1

Cycles: 1

Example: `RLF REG1,0`

Before Instruction

REG1	=	1110 0110
C	=	0

After Instruction

REG1	=	1110 0110
W	=	1100 1100
C	=	1

RRF **Rotate Right f through Carry**

Syntax: `[label] RRF f,d`

Operands: $0 \leq f \leq 127$
 $d \in [0,1]$

Operation: See description below

Status Affected: C

Description: The contents of register 'f' are rotated one bit to the right through the Carry flag. If 'd' is '0', the result is placed in the W register. If 'd' is '1', the result is placed back in register 'f'.

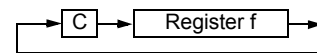

PIC16(L)F18856/76

SLEEP Enter Sleep mode

Syntax: [*label*] SLEEP

Operands: None

Operation: 00h → WDT,
0 → WDT prescaler,
1 → \overline{TO} ,
0 → \overline{PD}

Status Affected: \overline{TO} , \overline{PD}

Description: The power-down Status bit, \overline{PD} is cleared. Time-out Status bit, \overline{TO} is set. Watchdog Timer and its prescaler are cleared.
See [Section 8.2 “Sleep Mode”](#) for more information.

SUBLW Subtract W from literal

Syntax: [*label*] SUBLW *k*

Operands: $0 \leq k \leq 255$

Operation: $k - (W) \rightarrow (W)$

Status Affected: C, DC, Z

Description: The W register is subtracted (2's complement method) from the 8-bit literal 'k'. The result is placed in the W register.

C = 0	$W > k$
C = 1	$W \leq k$
DC = 0	$W<3:0> > k<3:0>$
DC = 1	$W<3:0> \leq k<3:0>$

SUBWF Subtract W from f

Syntax: [*label*] SUBWF *f,d*

Operands: $0 \leq f \leq 127$
 $d \in [0,1]$

Operation: $(f) - (W) \rightarrow (\text{destination})$

Status Affected: C, DC, Z

Description: Subtract (2's complement method) W register from register 'f'. If 'd' is '0', the result is stored in the W register. If 'd' is '1', the result is stored back in register 'f'.

C = 0	$W > f$
C = 1	$W \leq f$
DC = 0	$W<3:0> > f<3:0>$
DC = 1	$W<3:0> \leq f<3:0>$

SUBWFB Subtract W from f with Borrow

Syntax: SUBWFB *f* {*d*}

Operands: $0 \leq f \leq 127$
 $d \in [0,1]$

Operation: $(f) - (W) - (\overline{B}) \rightarrow \text{dest}$

Status Affected: C, DC, Z

Description: Subtract W and the BORROW flag (CARRY) from register 'f' (2's complement method). If 'd' is '0', the result is stored in W. If 'd' is '1', the result is stored back in register 'f'.

SWAPF Swap Nibbles in f

Syntax: [*label*] SWAPF *f,d*

Operands: $0 \leq f \leq 127$
 $d \in [0,1]$

Operation: $(f<3:0>) \rightarrow (\text{destination}<7:4>)$,
 $(f<7:4>) \rightarrow (\text{destination}<3:0>)$

Status Affected: None

Description: The upper and lower nibbles of register 'f' are exchanged. If 'd' is '0', the result is placed in the W register. If 'd' is '1', the result is placed in register 'f'.

TRIS Load TRIS Register with W

Syntax: [*label*] TRIS *f*

Operands: $5 \leq f \leq 7$

Operation: $(W) \rightarrow \text{TRIS register 'f'}$

Status Affected: None

Description: Move data from W register to TRIS register.
When 'f' = 5, TRISA is loaded.
When 'f' = 6, TRISB is loaded.
When 'f' = 7, TRISC is loaded.

PIC16(L)F18856/76

XORLW Exclusive OR literal with W

Syntax: [*label*] XORLW k
Operands: $0 \leq k \leq 255$
Operation: (W) .XOR. k \rightarrow (W)
Status Affected: Z
Description: The contents of the W register are XOR'ed with the 8-bit literal 'k'. The result is placed in the W register.

XORWF Exclusive OR W with f

Syntax: [*label*] XORWF f,d
Operands: $0 \leq f \leq 127$
 $d \in [0,1]$
Operation: (W) .XOR. (f) \rightarrow (destination)
Status Affected: Z
Description: Exclusive OR the contents of the W register with register 'f'. If 'd' is '0', the result is stored in the W register. If 'd' is '1', the result is stored back in register 'f'.

PIC16(L)F18856/76

37.0 ELECTRICAL SPECIFICATIONS

37.1 Absolute Maximum Ratings^(†)

Ambient temperature under bias	-40°C to +125°C
Storage temperature	-65°C to +150°C
Voltage on pins with respect to V _{SS}	
on V _{DD} pin	
PIC16F18856/76	-0.3V to +6.5V
PIC16LF18856/76	-0.3V to +4.0V
on $\overline{\text{MCLR}}$ pin	-0.3V to +9.0V
on all other pins	-0.3V to (V _{DD} + 0.3V)
Maximum current	
on V _{SS} pin ⁽¹⁾	
-40°C ≤ T _A ≤ +85°C	350 mA
85°C < T _A ≤ +125°C	120 mA
on V _{DD} pin for 28-Pin devices ⁽¹⁾	
-40°C ≤ T _A ≤ +85°C	250 mA
85°C < T _A ≤ +125°C	85 mA
on V _{DD} pin for 40-Pin devices ⁽¹⁾	
-40°C ≤ T _A ≤ +85°C	350 mA
85°C < T _A ≤ +125°C	120 mA
on any standard I/O pin	±50 mA
Clamp current, I _K (V _{PIN} < 0 or V _{PIN} > V _{DD})	±20 mA
Total power dissipation ⁽²⁾	800 mW

Note 1: Maximum current rating requires even load distribution across I/O pins. Maximum current rating may be limited by the device package power dissipation characterizations, see [Table 37-6](#) to calculate device specifications.

2: Power dissipation is calculated as follows:

$$P_{DIS} = V_{DD} \times \{I_{DD} - \sum I_{OH}\} + \sum \{(V_{DD} - V_{OH}) \times I_{OH}\} + \sum (V_{OI} \times I_{OL})$$

† NOTICE: Stresses above those listed under “Absolute Maximum Ratings” may cause permanent damage to the device. This is a stress rating only and functional operation of the device at those or any other conditions above those indicated in the operation listings of this specification is not implied. Exposure above maximum rating conditions for extended periods may affect device reliability.

PIC16(L)F18856/76

37.2 Standard Operating Conditions

The standard operating conditions for any device are defined as:

Operating Voltage: $V_{DDMIN} \leq V_{DD} \leq V_{DDMAX}$

Operating Temperature: $T_{A_MIN} \leq T_A \leq T_{A_MAX}$

V_{DD} — Operating Supply Voltage⁽¹⁾

PIC16LF18856/76

V_{DDMIN} (F_{osc} ≤ 16 MHz) +1.8V

V_{DDMIN} (F_{osc} ≤ 32 MHz) +2.5V

V_{DDMAX} +3.6V

PIC16F18856/76

V_{DDMIN} (F_{osc} ≤ 16 MHz) +2.3V

V_{DDMIN} (F_{osc} ≤ 32 MHz) +2.5V

V_{DDMAX} +5.5V

T_A — Operating Ambient Temperature Range

Industrial Temperature

T_{A_MIN} -40°C

T_{A_MAX} +85°C

Extended Temperature

T_{A_MIN} -40°C

T_{A_MAX} +125°C

Note 1: See Parameter [Supply Voltage](#), DS Characteristics: Supply Voltage.

PIC16(L)F18856/76

FIGURE 37-1: VOLTAGE FREQUENCY GRAPH, $-40^{\circ}\text{C} \leq T_A \leq +125^{\circ}\text{C}$, PIC16F18856/76 ONLY

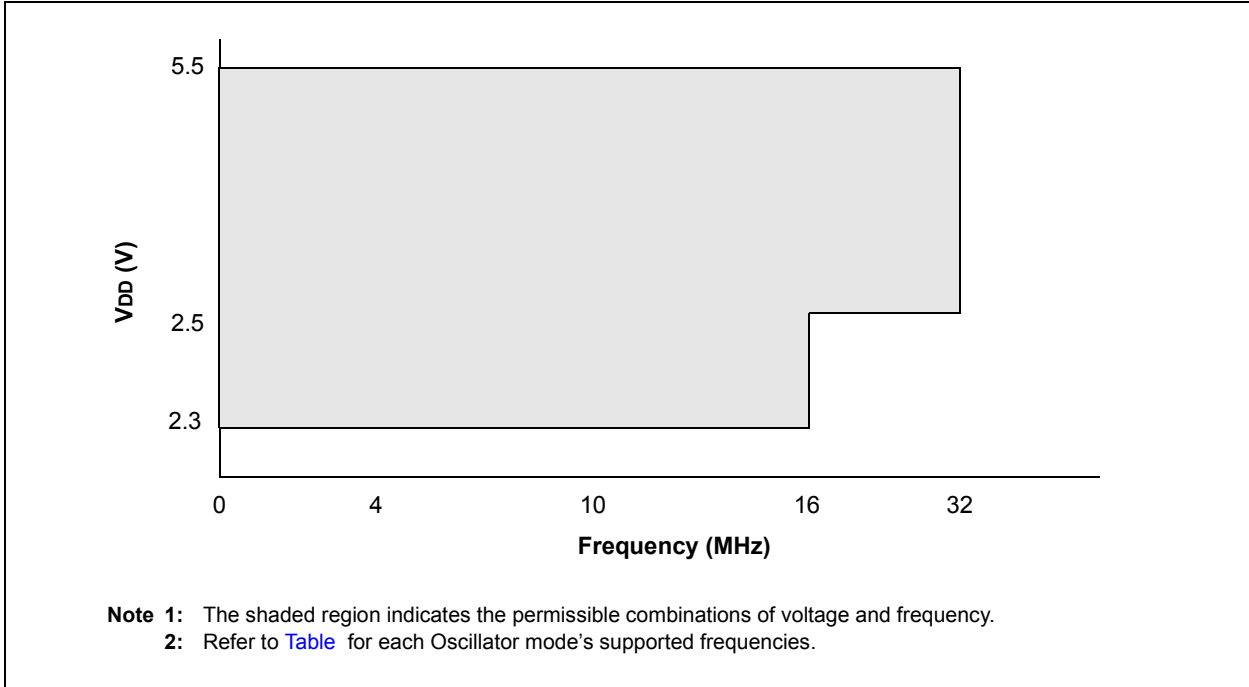
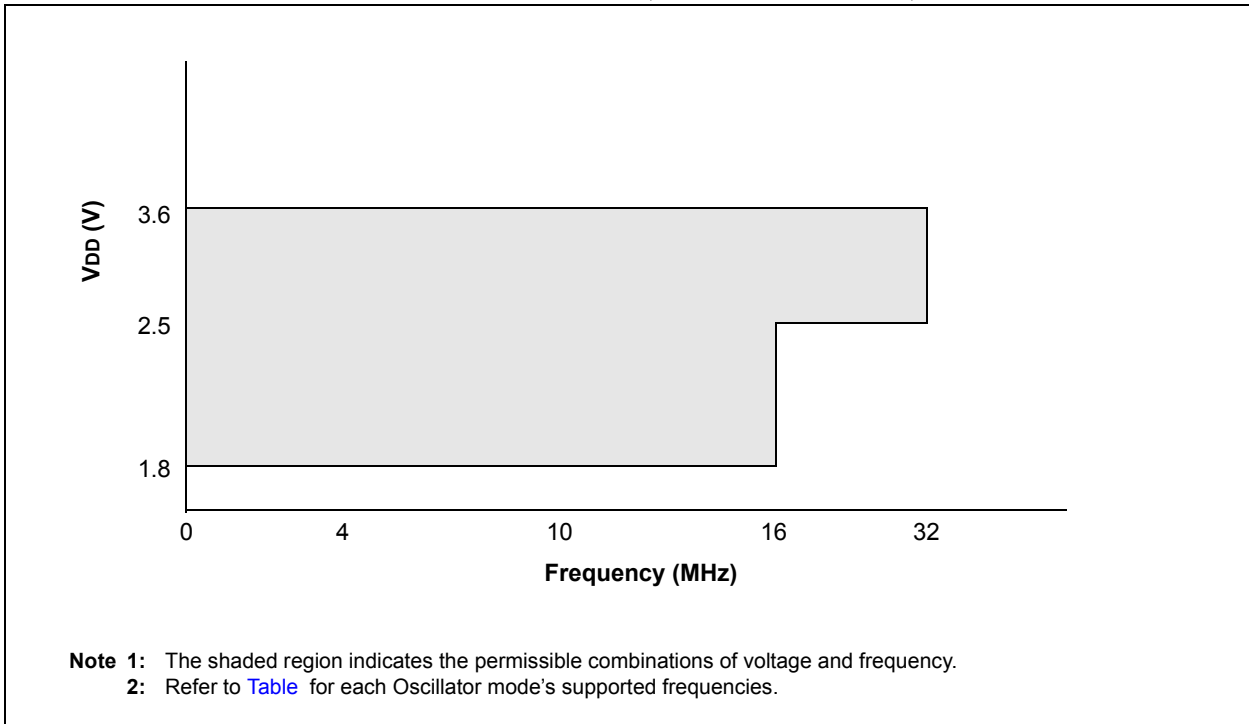

FIGURE 37-2: VOLTAGE FREQUENCY GRAPH, $-40^{\circ}\text{C} \leq T_A \leq +125^{\circ}\text{C}$, PIC16LF18856/76 ONLY



PIC16(L)F18856/76

37.3 DC Characteristics

TABLE 37-1: SUPPLY VOLTAGE

PIC16LF18856/76		Standard Operating Conditions (unless otherwise stated)					
PIC16F18856/76							
Param. No.	Sym.	Characteristic	Min.	Typ.†	Max.	Units	Conditions
Supply Voltage							
D002	VDD		1.8	—	3.6	V	Fosc ≤ 16 MHz
			2.5	—	3.6	V	Fosc > 16 MHz
D002	VDD		2.3	—	5.5	V	Fosc ≤ 16 MHz
			2.5	—	5.5	V	Fosc ≥ 16 MHz
RAM Data Retention⁽¹⁾							
D003	VDR		1.5	—	—	V	Device in Sleep mode
D003	VDR		1.5	—	—	V	Device in Sleep mode
Power-on Reset Release Voltage⁽²⁾							
D004	VPOR		—	1.6	—	V	BOR or LPBOR disabled ⁽³⁾
D004	VPOR		—	1.6	—	V	BOR or LPBOR disabled ⁽³⁾
Power-on Reset Rearm Voltage⁽²⁾							
D005	VPORR		—	0.8	—	V	BOR or LPBOR disabled ⁽³⁾
D005	VPORR		—	1.2	—	V	BOR or LPBOR disabled ⁽³⁾
VDD Rise Rate to ensure internal Power-on Reset signal⁽²⁾							
D006	SVDD		0.05	—	—	V/ms	BOR or LPBOR disabled ⁽³⁾
D006	SVDD		0.05	—	—	V/ms	BOR or LPBOR disabled ⁽³⁾

† Data in "Typ." column is at 3.0V, 25°C unless otherwise stated. These parameters are for design guidance only and are not tested.

- Note 1:** This is the limit to which VDD can be lowered in Sleep mode without losing RAM data.
Note 2: See [Figure 37-3](#), POR and POR REARM with Slow Rising VDD.
Note 3: Please see [Table 37-11](#) for BOR and LPBOR trip point information.

PIC16(L)F18856/76

FIGURE 37-3: POR AND POR REARM WITH SLOW RISING V_{DD}

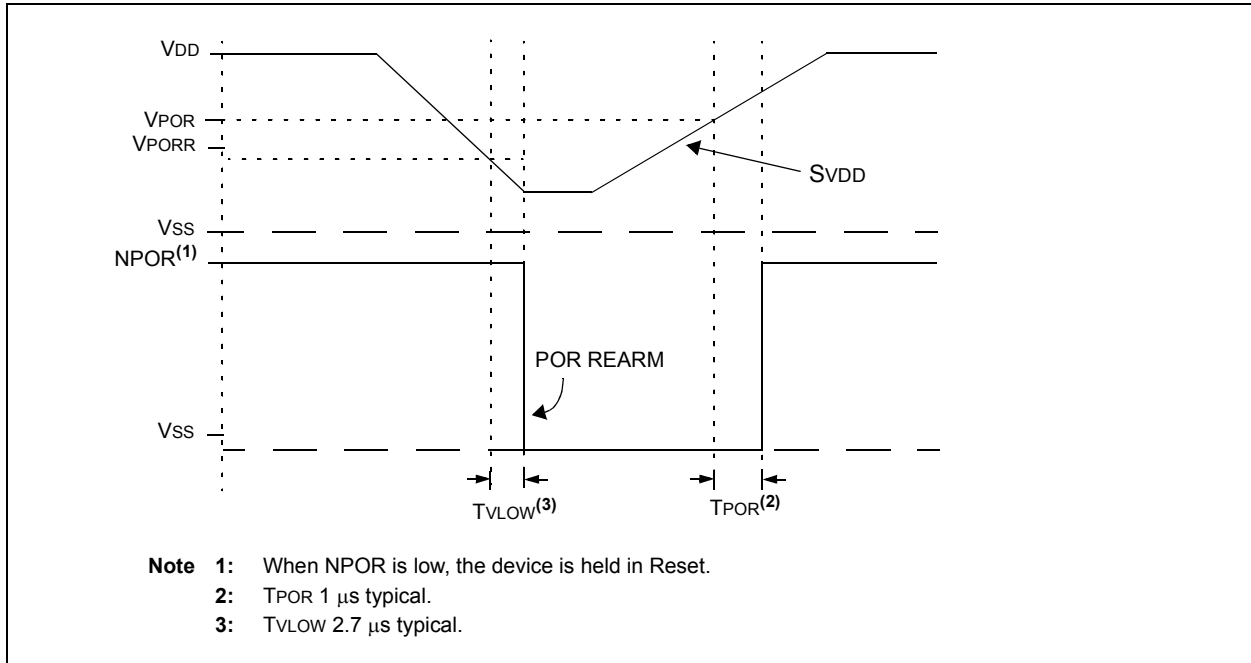

PIC16(L)F18856/76

TABLE 37-2: SUPPLY CURRENT (IDD)^(1,2,4)

PIC16LF18856/76			Standard Operating Conditions (unless otherwise stated)					
PIC16F18856/76								
Param. No.	Symbol	Device Characteristics	Min.	Typ.†	Max.	Units	Conditions	
							VDD	Note
D100	IDD _{XT4}	XT = 4 MHz	—	360	600	μA	3.0V	
D100	IDD _{XT4}	XT = 4 MHz	—	380	700	μA	3.0V	
D101	IDD _{HFO16}	HFINTOSC = 16 MHz	—	1.4	2.0	mA	3.0V	
D101	IDD _{HFO16}	HFINTOSC = 16 MHz	—	1.5	2.1	mA	3.0V	
D102	IDD _{HFOPLL}	HFINTOSC = 32 MHz	—	2.6	3.6	mA	3.0V	
D102	IDD _{HFOPLL}	HFINTOSC = 32 MHz	—	2.7	3.7	mA	3.0V	
D103	IDD _{HSPLL32}	HS+PLL = 32 MHz	—	2.6	3.6	mA	3.0V	
D103	IDD _{HSPLL32}	HS+PLL = 32 MHz	—	2.7	3.7	mA	3.0V	
D104	IDD _{IDLE}	IDLE mode, HFINTOSC = 16 MHz	—	1.05	—	mA	3.0V	
D104	IDD _{IDLE}	IDLE mode, HFINTOSC = 16 MHz	—	1.15	—	mA	3.0V	
D105	IDD _{DOZE} ⁽³⁾	DOZE mode, HFINTOSC = 16 MHz, Doze Ratio = 16	—	1.1	—	mA	3.0V	
D105	IDD _{DOZE} ⁽³⁾	DOZE mode, HFINTOSC = 16 MHz, Doze Ratio = 16	—	1.2	—	mA	3.0V	

† Data in "Typ." column is at 3.0V, 25°C unless otherwise stated. These parameters are for design guidance only and are not tested.

- Note**
- 1: The test conditions for all IDD measurements in active operation mode are: OSC1 = external square wave, from rail-to-rail; all I/O pins are outputs driven low; MCLR = VDD; WDT disabled.
 - 2: The supply current is mainly a function of the operating voltage and frequency. Other factors, such as I/O pin loading and switching rate, oscillator type, internal code execution pattern and temperature, also have an impact on the current consumption.
 - 3: $IDD_{DOZE} = [IDD_{IDLE} \cdot (N-1)/N] + IDD_{HFO16}/N$ where N = DOZE Ratio (Register 8-2).
 - 4: PMD bits are all in the default state, no modules are disabled.

PIC16(L)F18856/76

TABLE 37-3: POWER-DOWN CURRENT (IPD)^(1,2)

PIC16LF18856/76				Standard Operating Conditions (unless otherwise stated)					
PIC16F18856/76				Standard Operating Conditions (unless otherwise stated) VREGPM = 1					
Param. No.	Symbol	Device Characteristics	Min.	Typ.†	Max. +85°C	Max. +125°C	Units	Conditions	
								VDD	Note
D200	IPD	IPD Base	—	0.05	2	9	μA	3.0V	
D200	IPD	IPD Base	—	0.4	4	12	μA	3.0V	
D200A			—	10	15	20	μA	3.0V	VREGPM = 0
D201	IPD_WDT	Low-Frequency Internal Oscillator/WDT	—	0.4	—	—	μA	3.0V	
D201	IPD_WDT	Low-Frequency Internal Oscillator/WDT	—	0.6	5	13	μA	3.0V	
D202	IPD_SOSC	Secondary Oscillator (SOSC)	—	0.6	5	13	μA	3.0V	
D202	IPD_SOSC	Secondary Oscillator (SOSC)	—	0.8	8.5	15	μA	3.0V	
D203	IPD_FVR	FVR	—	8	18	—	μA	3.0V	
D203	IPD_FVR	FVR	—	10	20	—	μA	3.0V	
D204	IPD_BOR	Brown-out Reset (BOR)	—	9	14	18	μA	3.0V	
D204	IPD_BOR	Brown-out Reset (BOR)	—	14	19	21	μA	3.0V	
D205	IPD_LPBOR	Low-Power Brown-out Reset (LPBOR)	—	0.5	—	—	μA	3.0V	
D205	IPD_LPBOR	Low-Power Brown-out Reset (LPBOR)	—	0.7	—	—	μA	3.0V	
D206	IPD_ADCA	ADC - Active	—	250	—	—	μA	3.0V	ADC is converting ⁽⁴⁾
D206	IPD_ADCA	ADC - Active	—	280	—	—	μA	3.0V	ADC is converting ⁽⁴⁾
D207	IPD_CMP	Comparator	—	25	38	40	μA	3.0V	
D207	IPD_CMP	Comparator	—	28	40	50	μA	3.0V	

† Data in "Typ." column is at 3.0V, 25°C unless otherwise stated. These parameters are for design guidance only and are not tested.

- Note**
- 1: The peripheral current is the sum of the base IDD and the additional current consumed when this peripheral is enabled. The peripheral Δ current can be determined by subtracting the base IDD or IPD current from this limit. Max. values should be used when calculating total current consumption.
 - 2: The power-down current in Sleep mode does not depend on the oscillator type. Power-down current is measured with the part in Sleep mode with all I/O pins in high-impedance state and tied to VSS.
 - 3: All peripheral currents listed are on a per-peripheral basis if more than one instance of a peripheral is available.
 - 4: ADC clock source is FRC.

PIC16(L)F18856/76

TABLE 37-4: I/O PORTS

Standard Operating Conditions (unless otherwise stated)							
Param. No.	Sym.	Characteristic	Min.	Typ†	Max.	Units	Conditions
D300 D301 D302 D303 D304 D305	V _{IL}	Input Low Voltage					
		I/O PORT:					
		with TTL buffer	—	—	0.8	V	4.5V ≤ V _{DD} ≤ 5.5V
			—	—	0.15 V _{DD}	V	1.8V ≤ V _{DD} ≤ 4.5V
		with Schmitt Trigger buffer	—	—	0.2 V _{DD}	V	2.0V ≤ V _{DD} ≤ 5.5V
		with I ² C levels	—	—	0.3 V _{DD}	V	
		with SMBus levels	—	—	0.8	V	2.7V ≤ V _{DD} ≤ 5.5V
D305		MCLR	—	—	0.2 V _{DD}	V	
D320 D321 D322 D323 D324 D325	V _{IH}	Input High Voltage					
		I/O PORT:					
		with TTL buffer	2.0	—	—	V	4.5V ≤ V _{DD} ≤ 5.5V
			0.25 V _{DD} + 0.8	—	—	V	1.8V ≤ V _{DD} ≤ 4.5V
		with Schmitt Trigger buffer	0.8 V _{DD}	—	—	V	2.0V ≤ V _{DD} ≤ 5.5V
		with I ² C levels	0.7 V _{DD}	—	—	V	
		with SMBus levels	2.1	—	—	V	2.7V ≤ V _{DD} ≤ 5.5V
D325		MCLR	0.7 V _{DD}	—	—	V	
D340 D341 D342	I _{IL}	Input Leakage Current⁽¹⁾					
		I/O Ports	—	± 5	± 125	nA	V _{SS} ≤ V _{PIN} ≤ V _{DD} , Pin at high-impedance, 85°C
			—	± 5	± 1000	nA	V _{SS} ≤ V _{PIN} ≤ V _{DD} , Pin at high-impedance, 125°C
D342		MCLR ⁽²⁾	—	± 50	± 200	nA	V _{SS} ≤ V _{PIN} ≤ V _{DD} , Pin at high-impedance, 85°C
D350	I _{PUR}	Weak Pull-up Current					
			25	120	200	μA	V _{DD} = 3.0V, V _{PIN} = V _{SS}
D360	V _{OL}	Output Low Voltage					
		I/O ports	—	—	0.6	V	I _{OL} = 10.0mA, V _{DD} = 3.0V
D370	V _{OH}	Output High Voltage					
		I/O ports	V _{DD} - 0.7	—	—	V	I _{OH} = 6.0 mA, V _{DD} = 3.0V
D380	C _{IO}	All I/O pins					
			—	5	50	pF	

† Data in "Typ" column is at 3.0V, 25°C unless otherwise stated. These parameters are for design guidance only and are not tested.

Note 1: Negative current is defined as current sourced by the pin.

Note 2: The leakage current on the MCLR pin is strongly dependent on the applied voltage level. The specified levels represent normal operating conditions. Higher leakage current may be measured at different input voltages.

PIC16(L)F18856/76

TABLE 37-5: MEMORY PROGRAMMING SPECIFICATIONS

Standard Operating Conditions (unless otherwise stated)							
Param. No.	Sym.	Characteristic	Min.	Typ†	Max.	Units	Conditions
High Voltage Entry Programming Mode Specifications							
MEM01	V _{IHH}	Voltage on $\overline{\text{MCLR}}/\text{VPP}$ pin to enter programming mode	8	—	9	V	(Note 2, Note 3)
MEM02	I _{PPGM}	Current on $\overline{\text{MCLR}}/\text{VPP}$ pin during programming mode	—	1	—	mA	(Note 2)
Programming Mode Specifications							
MEM10	V _{BE}	VDD for Bulk Erase	—	2.7	—	V	
MEM11	I _{DDPGM}	Supply Current during Programming operation	—	—	10	mA	
Data EEPROM Memory Specifications							
MEM20	E _D	DataEE Byte Endurance	100k	—	—	E/W	-40°C ≤ T _A ≤ +85°C Provided no other specifications are violated
MEM21	T _{D_RET}	Characteristic Retention	—	40	—	Year	
MEM22	N _{D_REF}	Total Erase/Write Cycles before Refresh	1M	10M	—	E/W	
MEM23	V _{D_RW}	VDD for Read or Erase/Write operation	V _{DDMIN}	—	V _{DDMAX}	V	
MEM24	T _{D_BEW}	Byte Erase and Write Cycle Time	—	4.0	5.0	ms	
Program Flash Memory Specifications							
MEM30	E _P	Flash Memory Cell Endurance	10k	—	—	E/W	-40°C ≤ T _A ≤ +85°C (Note 1)
MEM32	T _{P_RET}	Characteristic Retention	—	40	—	Year	Provided no other specifications are violated
MEM33	V _{P_RD}	VDD for Read operation	V _{DDMIN}	—	V _{DDMAX}	V	
MEM34	V _{P_REW}	VDD for Row Erase or Write operation	V _{DDMIN}	—	V _{DDMAX}	V	
MEM35	T _{P_REW}	Self-Timed Row Erase or Self-Timed Write	—	2.0	2.5	ms	

† Data in "Typ" column is at 3.0V, 25°C unless otherwise stated. These parameters are for design guidance only and are not tested.

- Note 1:** Flash Memory Cell Endurance for the Flash memory is defined as: One Row Erase operation and one Self-Timed Write.
- 2:** Required only if CONFIG4, bit LVP is disabled.
- 3:** The MPLAB ICD2 does not support variable VPP output. Circuitry to limit the ICD2 VPP voltage must be placed between the ICD2 and target system when programming or debugging with the ICD2.

PIC16(L)F18856/76

TABLE 37-6: THERMAL CHARACTERISTICS

Standard Operating Conditions (unless otherwise stated)

Param. No.	Sym.	Characteristic	Typ.	Units	Conditions
TH01	θ_{JA}	Thermal Resistance Junction to Ambient	60	°C/W	28-pin SPDIP package
			80	°C/W	28-pin SOIC package
			90	°C/W	28-pin SSOP package
			27.5	°C/W	28-pin UQFN 4x4 mm package
			27.5	°C/W	28-pin QFN 6x6mm package
			47.2	°C/W	40-pin PDIP package
			46	°C/W	44-pin TQFP package
			24.4	°C/W	44-pin QFN 8x8mm package
TH02	θ_{JC}	Thermal Resistance Junction to Case	31.4	°C/W	28-pin SPDIP package
			24	°C/W	28-pin SOIC package
			24	°C/W	28-pin SSOP package
			24	°C/W	28-pin UQFN 4x4mm package
			24	°C/W	28-pin QFN 6x6mm package
			24.7	°C/W	40-pin PDIP package
			14.5	°C/W	44-pin TQFP package
			20	°C/W	44-pin QFN 8x8mm package
TH03	T _{JMAX}	Maximum Junction Temperature	150	°C	
TH04	PD	Power Dissipation	—	W	PD = P _{INTERNAL} + P _{I/O}
TH05	P _{INTERNAL}	Internal Power Dissipation	—	W	P _{INTERNAL} = I _{DD} x V _{DD} ⁽¹⁾
TH06	P _{I/O}	I/O Power Dissipation	—	W	P _{I/O} = $\Sigma (I_{OL} * V_{OL}) + \Sigma (I_{OH} * (V_{DD} - V_{OH}))$
TH07	P _{DER}	Derated Power	—	W	P _{DER} = P _D MAX (T _J - T _A)/ θ_{JA} ⁽²⁾

Note 1: I_{DD} is current to run the chip alone without driving any load on the output pins.

Note 2: T_A = Ambient Temperature, T_J = Junction Temperature

PIC16(L)F18856/76

37.4 AC Characteristics

FIGURE 37-4: LOAD CONDITIONS

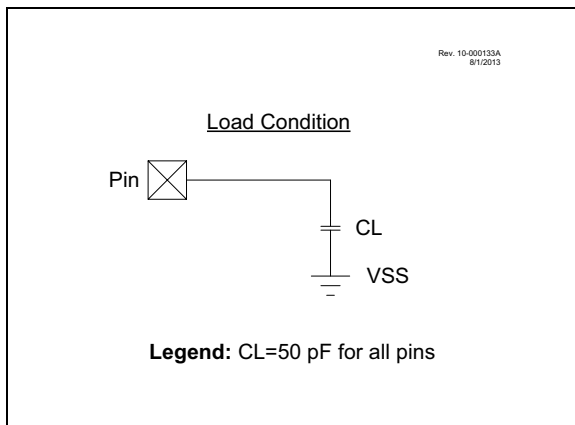

PIC16(L)F18856/76

FIGURE 37-5: CLOCK TIMING

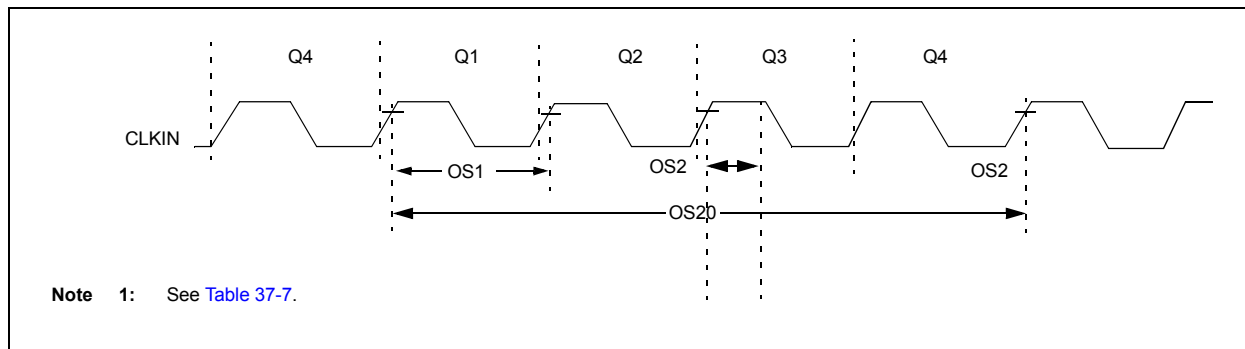

TABLE 37-7: EXTERNAL CLOCK/OSCILLATOR TIMING REQUIREMENTS

Standard Operating Conditions (unless otherwise stated)							
Param. No.	Sym.	Characteristic	Min.	Typ†	Max.	Units	Conditions
ECL Oscillator							
OS1	F_{ECL}	Clock Frequency	—	—	500	kHz	
OS2	T_{ECL_DC}	Clock Duty Cycle	40	—	60	%	
ECM Oscillator							
OS3	F_{ECM}	Clock Frequency	—	—	8	MHz	
OS4	T_{ECM_DC}	Clock Duty Cycle	40	—	60	%	
ECH Oscillator							
OS5	F_{ECH}	Clock Frequency	—	—	32	MHz	
OS6	T_{ECH_DC}	Clock Duty Cycle	40	—	60	%	
LP Oscillator							
OS7	F_{LP}	Clock Frequency	—	—	100	kHz	Note 4
XT Oscillator							
OS8	F_{XT}	Clock Frequency	—	—	4	MHz	Note 4
HS Oscillator							
OS9	F_{HS}	Clock Frequency	—	—	20	MHz	Note 4
System Oscillator							
OS20	F_{OSC}	System Clock Frequency	—	—	32	MHz	(Note 2, Note 3)
OS21	F_{CY}	Instruction Frequency	—	$F_{OSC}/4$	—	MHz	
OS22	T_{CY}	Instruction Period	125	$1/F_{CY}$	—	ns	

* These parameters are characterized but not tested.

† Data in "Typ" column is at 3.0V, 25°C unless otherwise stated. These parameters are for design guidance only and are not tested.

- Note 1:** Instruction cycle period (T_{CY}) equals four times the input oscillator time base period. All specified values are based on characterization data for that particular oscillator type under standard operating conditions with the device executing code. Exceeding these specified limits may result in an unstable oscillator operation and/or higher than expected current consumption. All devices are tested to operate at "min" values with an external clock applied to OSC1 pin. When an external clock input is used, the "max" cycle time limit is "DC" (no clock) for all devices.
- Note 2:** The system clock frequency (F_{OSC}) is selected by the "main clock switch controls" as described in [Section 6.0 "Oscillator Module \(with Fail-Safe Clock Monitor\)"](#).
- Note 3:** The system clock frequency (F_{OSC}) must meet the voltage requirements defined in the [Section 37.2 "Standard Operating Conditions"](#).
- Note 4:** LP, XT and HS oscillator modes require an appropriate crystal or resonator to be connected to the device. For clocking the device with the external square wave, one of the EC mode selections must be used.

PIC16(L)F18856/76

TABLE 37-8: INTERNAL OSCILLATOR PARAMETERS⁽¹⁾

Standard Operating Conditions (unless otherwise stated)							
Param. No.	Sym.	Characteristic	Min.	Typ†	Max.	Units	Conditions
OS50	FHFOSC	Precision Calibrated HFINTOSC Frequency	—	4 8 12 16 32	—	MHz	(Note 2)
OS51	FHFOSCLP	Low-Power Optimized HFINTOSC Frequency	— —	1 2	— —	MHz MHz	
OS52	FMFOSC	Internal Calibrated MFINTOSC Frequency	—	500	—	kHz	
OS53*	FLFOSC	Internal LFINTOSC Frequency	—	31	—	kHz	(Note 3)
OS54*	THFOSCST	HFINTOSC Wake-up from Sleep Start-up Time	— —	11 50	20 —	μs μs	VREGPM = 0 VREGPM = 1
OS56	TLFOSCST	LFINTOSC Wake-up from Sleep Start-up Time	—	0.2	—	ms	

* These parameters are characterized but not tested.

† Data in “Typ” column is at 3.0V, 25°C unless otherwise stated. These parameters are for design guidance only and are not tested.

- Note 1:** To ensure these oscillator frequency tolerances, VDD and VSS must be capacitively decoupled as close to the device as possible. 0.1 μF and 0.01 μF values in parallel are recommended.
- 2:** See [Figure 37-6: Precision Calibrated HFINTOSC Frequency Accuracy Over Device VDD and Temperature](#), [Figure 38-78 HFINTOSC Typical Frequency Error, PIC16LF18856/76 Only](#) and [Figure 38-79 HFINTOSC Typical Frequency Error, PIC16F18856/76 Only](#).
- 3:** See [Figure 38-7 LFINTOSC Frequency, PIC16LF18856/76 Only](#) and [Figure 38-8: LFINTOSC Frequency, PIC16F18856/76 only](#).

PIC16(L)F18856/76

FIGURE 37-6: PRECISION CALIBRATED HFINTOSC FREQUENCY ACCURACY OVER DEVICE VDD AND TEMPERATURE

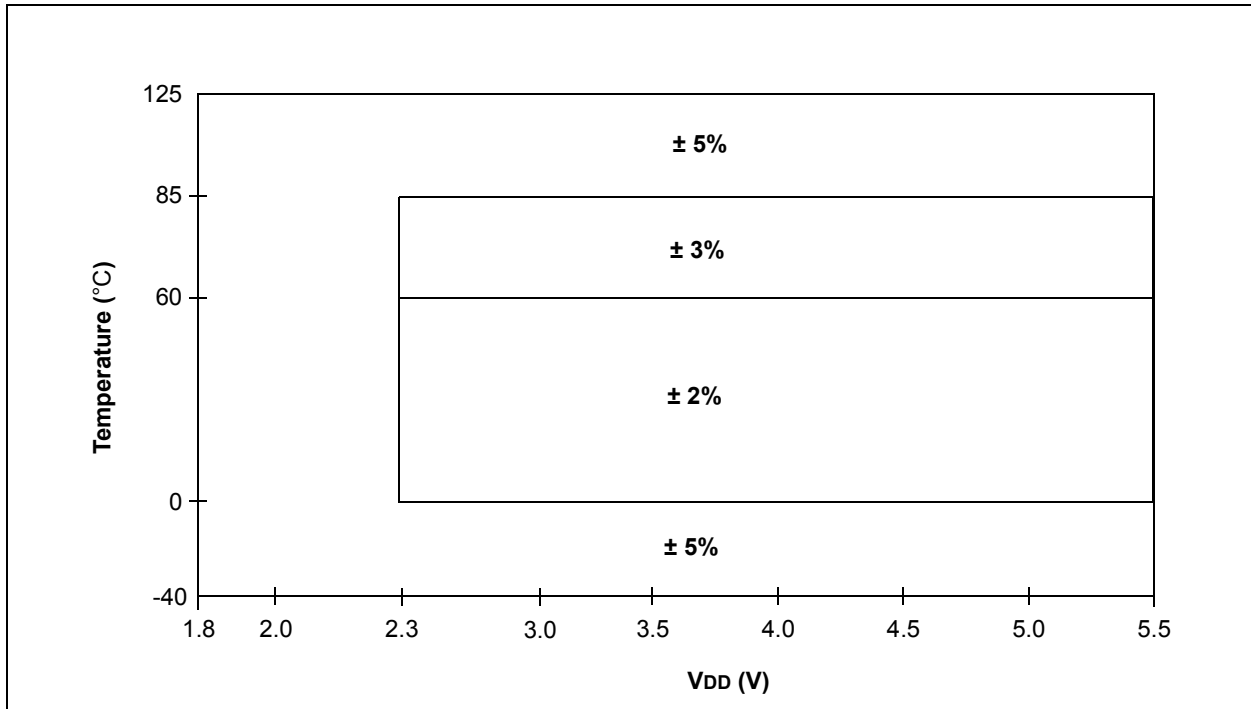

PIC16(L)F18856/76

TABLE 37-9: PLL SPECIFICATIONS

Standard Operating Conditions (unless otherwise stated) $V_{DD} \geq 2.5V$							
Param. No.	Sym.	Characteristic	Min.	Typ†	Max.	Units	Conditions
PLL01	FPLLIN	PLL Input Frequency Range	4	—	8	MHz	
PLL02	FPLLOUT	PLL Output Frequency Range	16	—	32	MHz	Note 1
PLL03	TPLLST	PLL Lock Time from Start-up	—	200	—	μs	
PLL04	FPLLJIT	PLL Output Frequency Stability (Jitter)	-0.25	—	0.25	%	

* These parameters are characterized but not tested.

† Data in “Typ” column is at 5V, 25°C unless otherwise stated. These parameters are for design guidance only and are not tested.

Note 1: The output frequency of the PLL must meet the FOSC requirements listed in Parameter D002.

PIC16(L)F18856/76

FIGURE 37-7: CLKOUT AND I/O TIMING

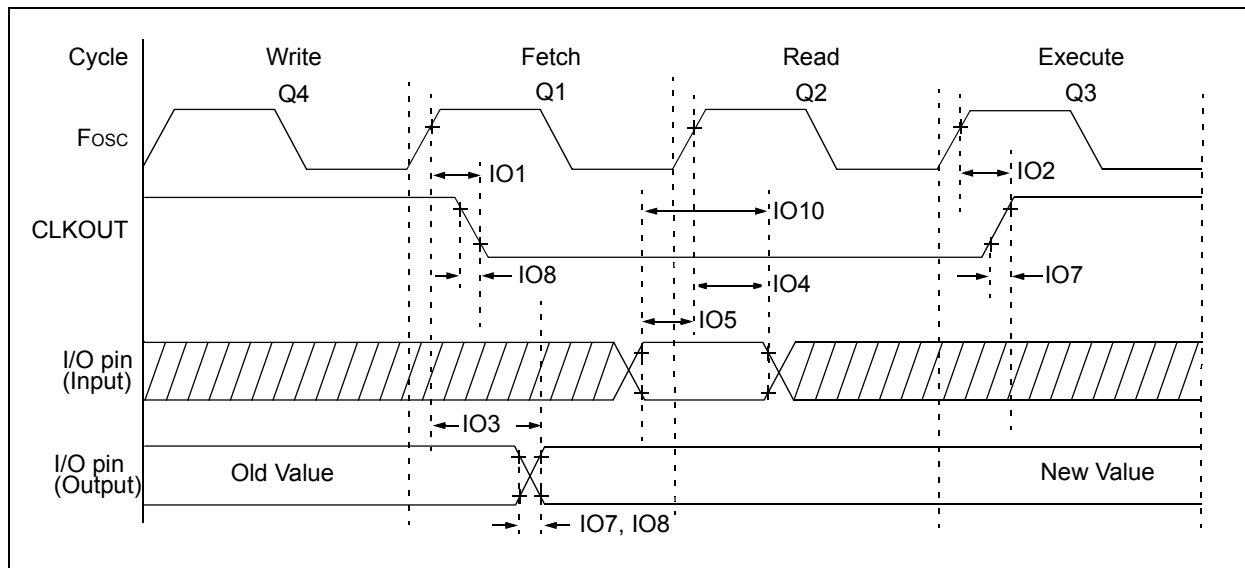

TABLE 37-10: I/O AND CLKOUT TIMING SPECIFICATIONS

Standard Operating Conditions (unless otherwise stated)							
Param. No.	Sym.	Characteristic	Min.	Typ†	Max.	Units	Conditions
IO1*	$T_{CLKOUTH}$	CLKOUT rising edge delay (rising edge Fosc (Q1 cycle) to falling edge CLKOUT)	—	—	70	ns	
IO2*	$T_{CLKOUTL}$	CLKOUT falling edge delay (rising edge Fosc (Q3 cycle) to rising edge CLKOUT)	—	—	72	ns	
IO3*	T_{IO_VALID}	Port output valid time (rising edge Fosc (Q1 cycle) to port valid)	—	50	70	ns	
IO4*	T_{IO_SETUP}	Port input setup time (Setup time before rising edge Fosc – Q2 cycle)	20	—	—	ns	
IO5*	T_{IO_HOLD}	Port input hold time (Hold time after rising edge Fosc – Q2 cycle)	50	—	—	ns	
IO6*	T_{IOR_SLREN}	Port I/O rise time, slew rate enabled	—	25	—	ns	$V_{DD} = 3.0V$
IO7*	T_{IOR_SLRDIS}	Port I/O rise time, slew rate disabled	—	5	—	ns	$V_{DD} = 3.0V$
IO8*	T_{IOF_SLREN}	Port I/O fall time, slew rate enabled	—	25	—	ns	$V_{DD} = 3.0V$
IO9*	T_{IOF_SLRDIS}	Port I/O fall time, slew rate disabled	—	5	—	ns	$V_{DD} = 3.0V$
IO10*	T_{INT}	INT pin high or low time to trigger an interrupt	25	—	—	ns	
IO11*	T_{IOC}	Interrupt-on-Change minimum high or low time to trigger interrupt	25	—	—	ns	

*These parameters are characterized but not tested.

PIC16(L)F18856/76

FIGURE 37-8: RESET, WATCHDOG TIMER, OSCILLATOR START-UP TIMER AND POWER-UP TIMER TIMING

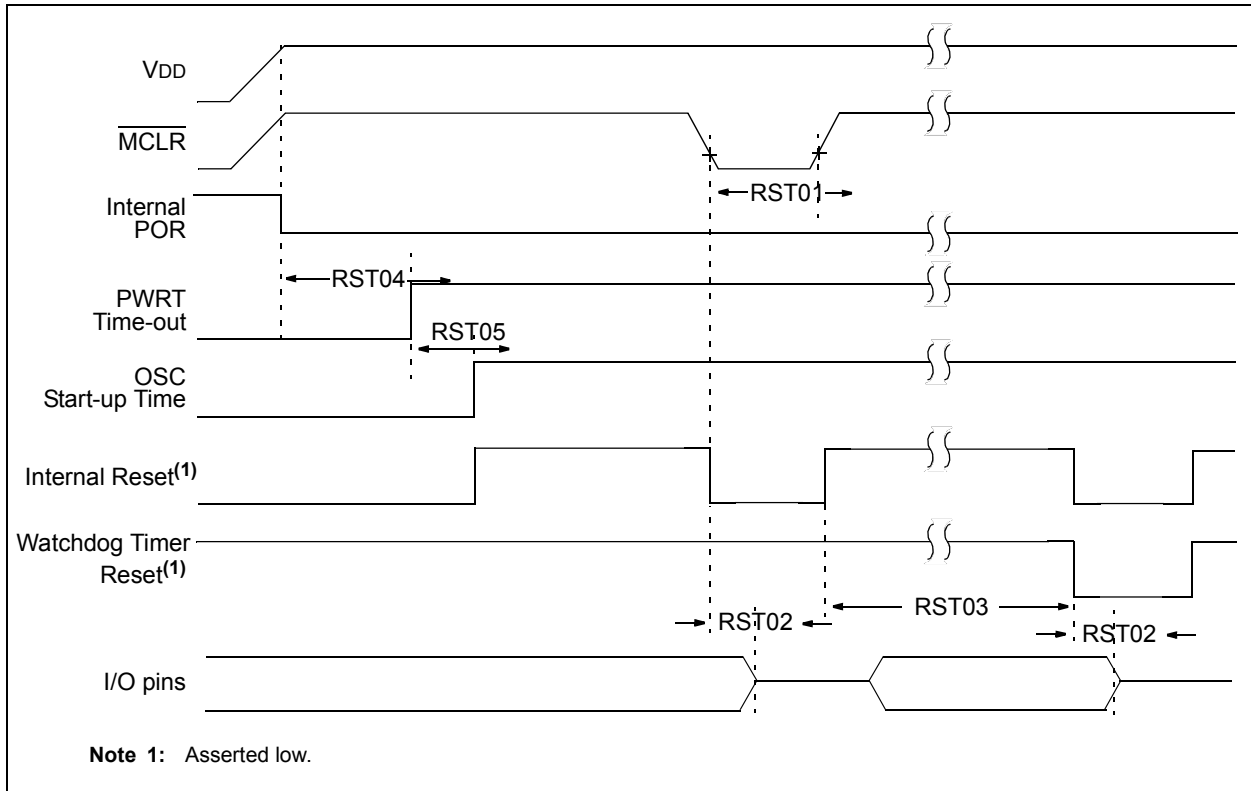
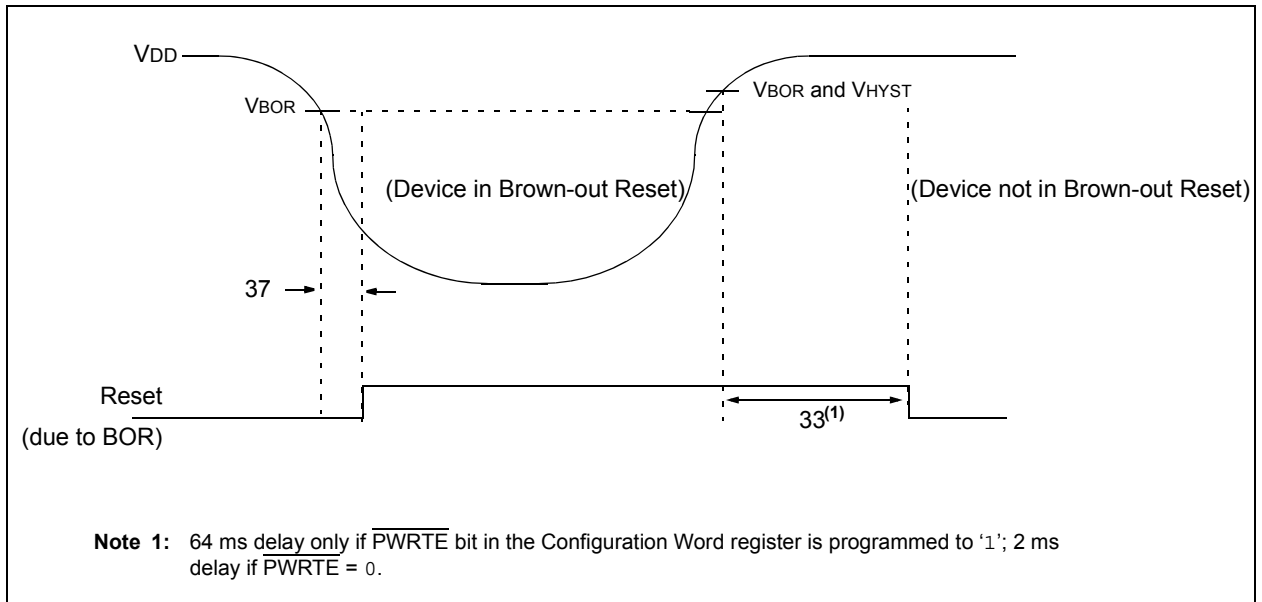

FIGURE 37-9: BROWN-OUT RESET TIMING AND CHARACTERISTICS



PIC16(L)F18856/76

TABLE 37-11: RESET, WDT, OSCILLATOR START-UP TIMER, POWER-UP TIMER, BROWN-OUT RESET AND LOW-POWER BROWN-OUT RESET SPECIFICATIONS

Standard Operating Conditions (unless otherwise stated)							
Param. No.	Sym.	Characteristic	Min.	Typ†	Max.	Units	Conditions
RST01*	TMCLR	MCLR Pulse Width Low to ensure Reset	2	—	—	μs	
RST02*	TIOZ	I/O high-impedance from Reset detection	—	—	2	μs	
RST03	TWDT	Watchdog Timer Time-out Period	—	16	—	ms	16 ms Nominal Reset Time
RST04*	TPWRT	Power-up Timer Period	—	65	—	ms	
RST05	TOST	Oscillator Start-up Timer Period ^(1,2)	—	1024	—	T _{OSC}	
RST06	VBOR	Brown-out Reset Voltage ⁽⁴⁾	2.55 2.30 1.80	2.70 2.45 1.90	2.85 2.60 2.10	V	BORV = 0 BORV = 1 (PIC16F18856/76) BORV = 1 (PIC16LF18856/76)
RST07	VBORHYS	Brown-out Reset Hysteresis	—	40	—	mV	
RST08	TBORDC	Brown-out Reset Response Time	—	3	—	μs	
RST09	VLPBOR	Low-Power Brown-out Reset Voltage	2.3	2.45	2.7	V	

* These parameters are characterized but not tested.

† Data in “Typ” column is at 3.0V, 25°C unless otherwise stated. These parameters are for design guidance only and are not tested.

Note 1: By design, the Oscillator Start-up Timer (OST) counts the first 1024 cycles, independent of frequency.

Note 2: To ensure these voltage tolerances, V_{DD} and V_{SS} must be capacitively decoupled as close to the device as possible. 0.1 μF and 0.01 μF values in parallel are recommended.

TABLE 37-12: ANALOG-TO-DIGITAL CONVERTER (ADC) ACCURACY SPECIFICATIONS^(1,2):

Operating Conditions (unless otherwise stated)							
V _{DD} = 3.0V, T _A = 25°C							
Param. No.	Sym.	Characteristic	Min.	Typ†	Max.	Units	Conditions
AD01	NR	Resolution	—	—	10	bit	
AD02	EIL	Integral Error	—	±0.1	±1.0	LSb	ADCREf+ = 3.0V, ADCREf- = 0V
AD03	EDL	Differential Error	—	±0.1	±1.0	LSb	ADCREf+ = 3.0V, ADCREf- = 0V
AD04	E _{OFF}	Offset Error	—	0.5	2.0	LSb	ADCREf+ = 3.0V, ADCREf- = 0V
AD05	E _{GN}	Gain Error	—	±0.2	±1.0	LSb	ADCREf+ = 3.0V, ADCREf- = 0V
AD06	V _{ADREF}	ADC Reference Voltage (ADREF+ - ADREF-)	1.8	—	V _{DD}	V	
AD07	V _{AIN}	Full-Scale Range	ADREF-	—	ADREF+	V	
AD08	Z _{AIN}	Recommended Impedance of Analog Voltage Source	—	10	—	kΩ	
AD09	R _{VREF}	ADC Voltage Reference Ladder Impedance	—	50	—	kΩ	Note 3

* These parameters are characterized but not tested.

† Data in “Typ” column is at 3.0V, 25°C unless otherwise stated. These parameters are for design guidance only and are not tested.

Note 1: Total Absolute Error is the sum of the offset, gain and integral non-linearity (INL) errors.

Note 2: The ADC conversion result never decreases with an increase in the input and has no missing codes.

Note 3: This is the impedance seen by the V_{REF} pads when the external reference pads are selected.

PIC16(L)F18856/76

TABLE 37-13: ANALOG-TO-DIGITAL CONVERTER (ADC) CONVERSION TIMING SPECIFICATIONS

Standard Operating Conditions (unless otherwise stated)							
Param. No.	Sym.	Characteristic	Min.	Typ†	Max.	Units	Conditions
AD20	TAD	ADC Clock Period	1	—	9	μs	Using Fosc as the ADC clock source ADOCS = 0
AD21			1	2	6	μs	Using FRC as the ADC clock source ADOCS = 1
AD22	TCNV	Conversion Time	—	11+3TCY	—	TAD	Set of GO/DONE bit to Clear of GO/DONE bit
AD23	TACQ	Acquisition Time	—	2	—	μs	
AD24	THCD	Sample and Hold Capacitor Disconnect Time	—	—	—	μs	Fosc-based clock source FRC-based clock source

* These parameters are characterized but not tested.

† Data in "Typ" column is at 3.0V, 25°C unless otherwise stated. These parameters are for design guidance only and are not tested.

FIGURE 37-10: ADC CONVERSION TIMING (ADC CLOCK Fosc-BASED)

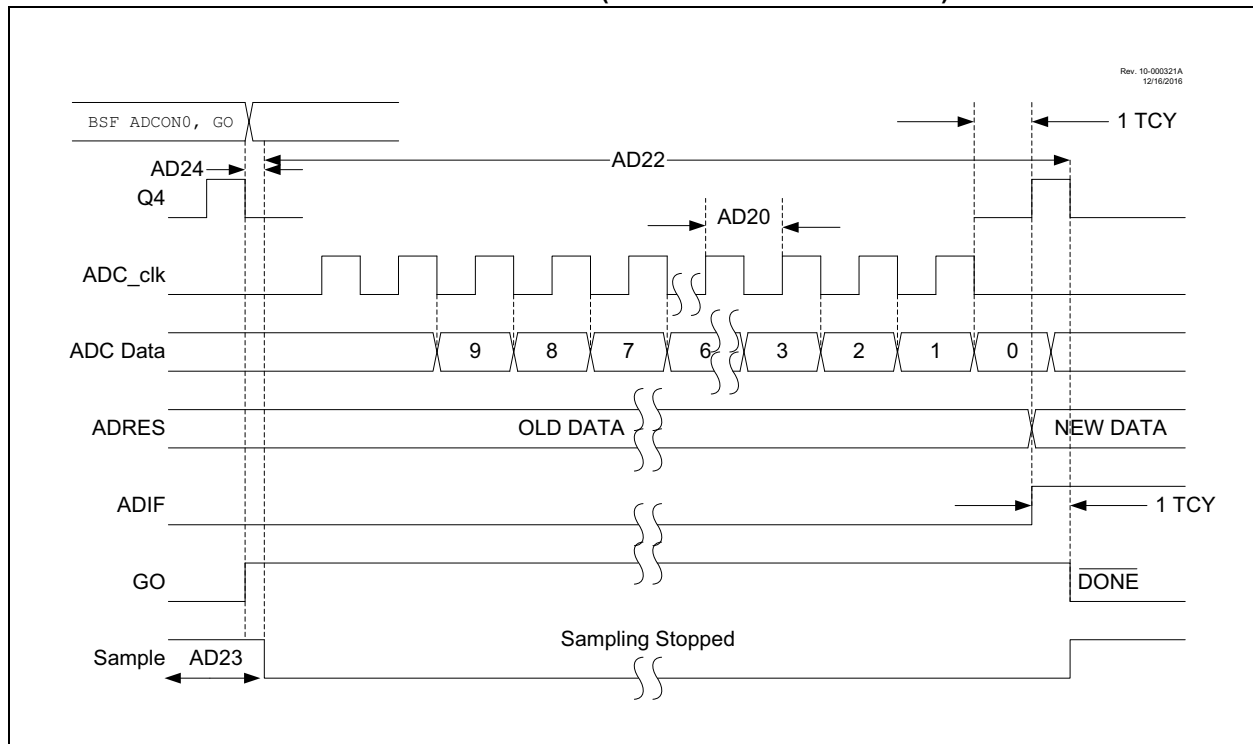

PIC16(L)F18856/76

FIGURE 37-11: ADC CONVERSION TIMING (ADC CLOCK FRC-BASED)

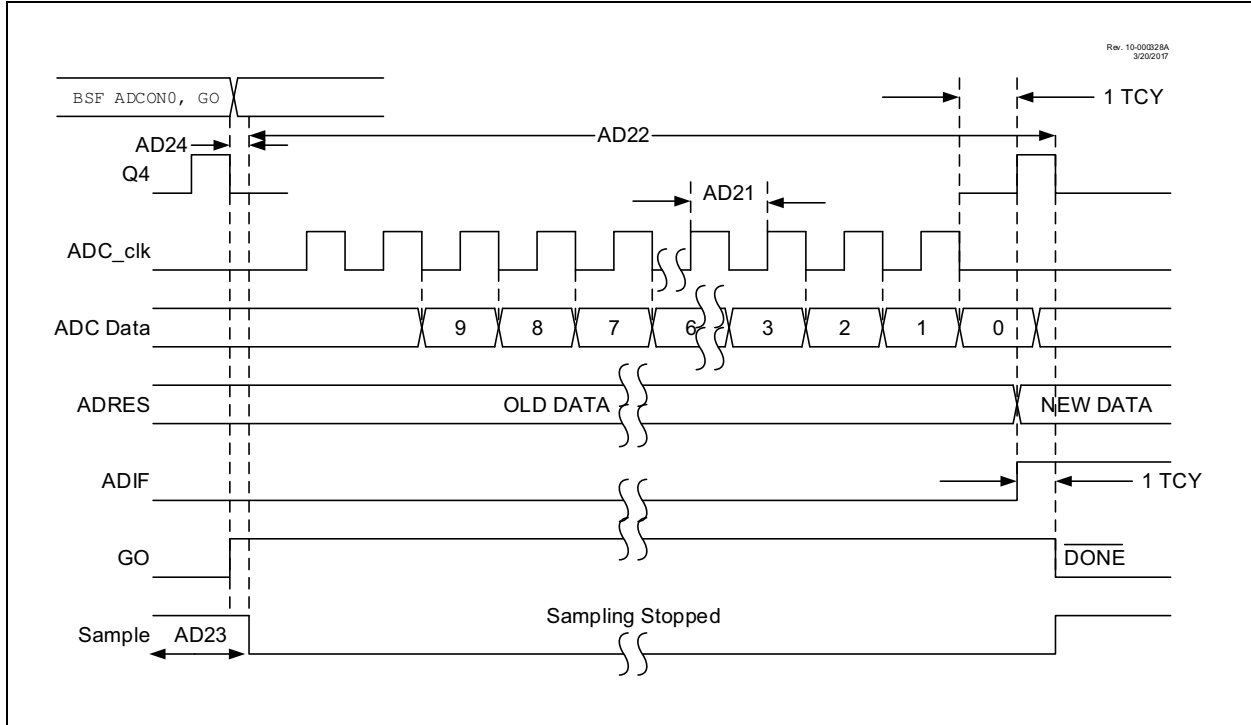

PIC16(L)F18856/76

TABLE 37-14: COMPARATOR SPECIFICATIONS

Operating Conditions (unless otherwise stated) V _{DD} = 3.0V, T _A = 25°C							
Param. No.	Sym.	Characteristics	Min.	Typ.	Max.	Units	Comments
CM01	V _{IOFF}	Input Offset Voltage	—	—	±30	mV	V _{ICM} = V _{DD} /2
CM02	V _{ICM}	Input Common Mode Range	GND	—	V _{DD}	V	
CM03	CMRR	Common Mode Input Rejection Ratio	—	50	—	dB	
CM04	V _{HYST}	Comparator Hysteresis	15	25	35	mV	
CM05	T _{RESP} ⁽¹⁾	Response Time, Rising Edge	—	300	600	ns	
		Response Time, Falling Edge	—	220	500	ns	

* These parameters are characterized but not tested.

- Note 1:** Response time measured with one comparator input at V_{DD}/2, while the other input transitions from V_{SS} to V_{DD}.
Note 2: A mode change includes changing any of the control register values, including module enable.

TABLE 37-15: 5-BIT DAC SPECIFICATIONS

Standard Operating Conditions (unless otherwise stated) V _{DD} = 3.0V, T _A = 25°C							
Param. No.	Sym.	Characteristics	Min.	Typ.	Max.	Units	Comments
DSB01	V _{LSB}	Step Size	—	(V _{DACREF+} - V _{DACREF-}) / 32	—	V	
DSB01	V _{ACC}	Absolute Accuracy	—	—	± 0.5	LSb	
DSB03*	R _{UNIT}	Unit Resistor Value	—	5000	—	Ω	
DSB04*	T _{ST}	Settling Time ⁽¹⁾	—	—	10	μs	

* These parameters are characterized but not tested.

† Data in "Typ" column is at 3.0V, 25°C unless otherwise stated. These parameters are for design guidance only and are not tested.

- Note 1:** Settling time measured while DACR<4:0> transitions from '00000' to '01111'.

TABLE 37-16: FIXED VOLTAGE REFERENCE (FVR) SPECIFICATIONS

Standard Operating Conditions (unless otherwise stated)							
Param. No.	Symbol	Characteristic	Min.	Typ.	Max.	Units	Conditions
FVR01	V _{FVR1}	1x Gain (1.024V)	-4	—	+4	%	V _{DD} ≥ 2.5V, -40°C to 85°C
FVR02	V _{FVR2}	2x Gain (2.048V)	-4	—	+4	%	V _{DD} ≥ 2.5V, -40°C to 85°C
FVR03	V _{FVR4}	4x Gain (4.096V)	-5	—	+5	%	V _{DD} ≥ 4.75V, -40°C to 85°C
FVR04	T _{FVRST}	FVR Start-up Time	—	25	—	us	

TABLE 37-17: ZERO CROSS DETECT (ZCD) SPECIFICATIONS

Standard Operating Conditions (unless otherwise stated) V _{DD} = 3.0V, T _A = 25°C							
Param. No.	Sym.	Characteristics	Min	Typ†	Max	Units	Comments
ZC01	V _{PINZC}	Voltage on Zero Cross Pin	—	0.75	—	V	
ZC02	I _{ZCD_MAX}	Maximum source or sink current	—	—	600	μA	
ZC03	T _{RESPH}	Response Time, Rising Edge	—	1	—	μs	
	T _{RESPL}	Response Time, Falling Edge	—	1	—	μs	

† Data in "Typ" column is at 3.0V, 25°C unless otherwise stated. These parameters are for design guidance only and are not tested.

PIC16(L)F18856/76

FIGURE 37-12: TIMER0 AND TIMER1 EXTERNAL CLOCK TIMINGS

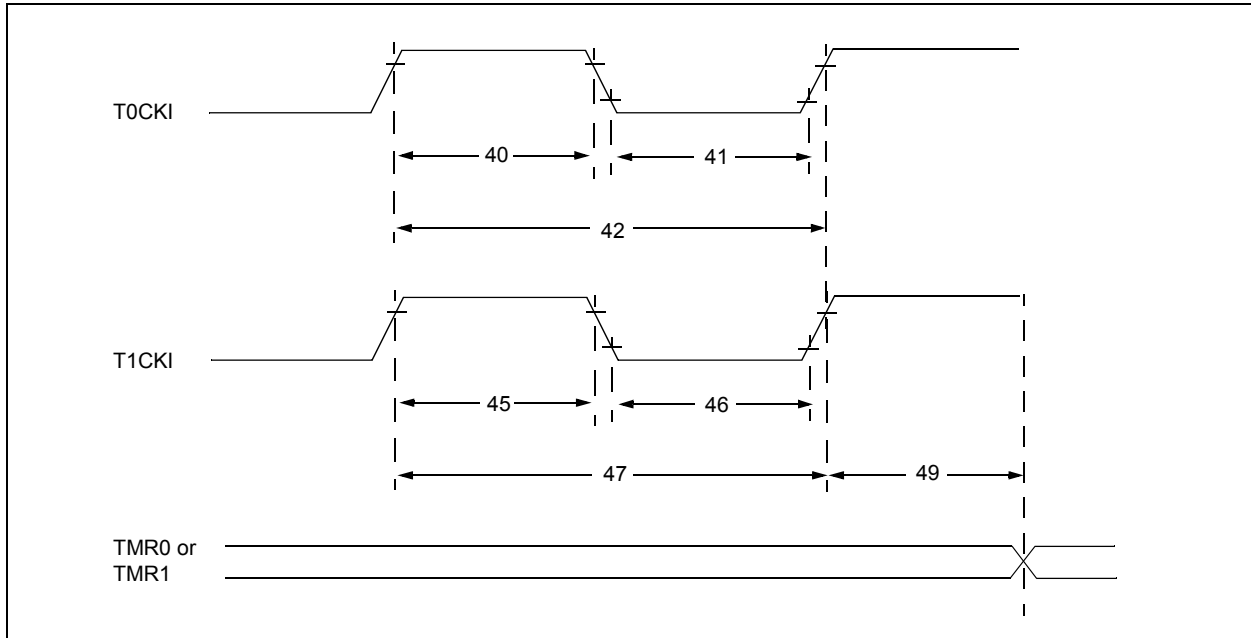

TABLE 37-18: TIMER0 AND TIMER1 EXTERNAL CLOCK REQUIREMENTS

Standard Operating Conditions (unless otherwise stated) Operating Temperature $-40^{\circ}\text{C} \leq T_A \leq +125^{\circ}\text{C}$								
Param. No.	Sym.	Characteristic		Min.	Typ†	Max.	Units	Conditions
40*	Tt0H	T0CKI High Pulse Width	No Prescaler	$0.5 T_{CY} + 20$	—	—	ns	
			With Prescaler	10	—	—	ns	
41*	Tt0L	T0CKI Low Pulse Width	No Prescaler	$0.5 T_{CY} + 20$	—	—	ns	
			With Prescaler	10	—	—	ns	
42*	Tt0P	T0CKI Period		Greater of: 20 or $\frac{T_{CY} + 40}{N}$	—	—	ns	N = prescale value
45*	Tt1H	T1CKI High Time	Synchronous, No Prescaler	$0.5 T_{CY} + 20$	—	—	ns	
			Synchronous, with Prescaler	15	—	—	ns	
			Asynchronous	30	—	—	ns	
46*	Tt1L	T1CKI Low Time	Synchronous, No Prescaler	$0.5 T_{CY} + 20$	—	—	ns	
			Synchronous, with Prescaler	15	—	—	ns	
			Asynchronous	30	—	—	ns	
47*	Tt1P	T1CKI Input Period	Synchronous	Greater of: 30 or $\frac{T_{CY} + 40}{N}$	—	—	ns	N = prescale value
			Asynchronous	60	—	—	ns	
48	Ft1	Secondary Oscillator Input Frequency Range (oscillator enabled by setting bit T1OSCEN)		32.4	32.768	33.1	kHz	
49*	TCKEZTMR1	Delay from External Clock Edge to Timer Increment		$2 T_{osc}$	—	$7 T_{osc}$	—	Timers in Sync mode

* These parameters are characterized but not tested.

† Data in "Typ" column is at 3.0V, 25°C unless otherwise stated. These parameters are for design guidance only and are not tested.

PIC16(L)F18856/76

FIGURE 37-13: CAPTURE/COMPARE/PWM TIMINGS (CCP)

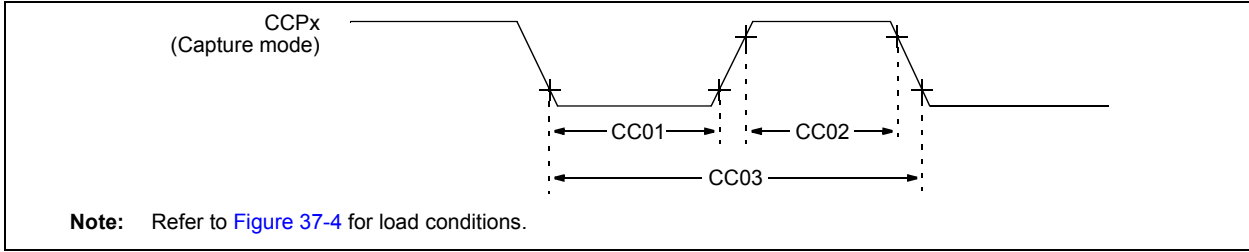

TABLE 37-19: CAPTURE/COMPARE/PWM REQUIREMENTS (CCP)

Standard Operating Conditions (unless otherwise stated)								
Operating Temperature $-40^{\circ}\text{C} \leq T_A \leq +125^{\circ}\text{C}$								
Param. No.	Sym.	Characteristic		Min.	Typ†	Max.	Units	Conditions
CC01*	TccL	CCPx Input Low Time	No Prescaler	$0.5T_{CY} + 20$	—	—	ns	
			With Prescaler	20	—	—	ns	
CC02*	TccH	CCPx Input High Time	No Prescaler	$0.5T_{CY} + 20$	—	—	ns	
			With Prescaler	20	—	—	ns	
CC03*	TccP	CCPx Input Period		$\frac{3T_{CY} + 40}{N}$	—	—	ns	N = prescale value

* These parameters are characterized but not tested.

† Data in "Typ" column is at 3.0V, 25°C unless otherwise stated. These parameters are for design guidance only and are not tested.

PIC16(L)F18856/76

FIGURE 37-14: CLC PROPAGATION TIMING

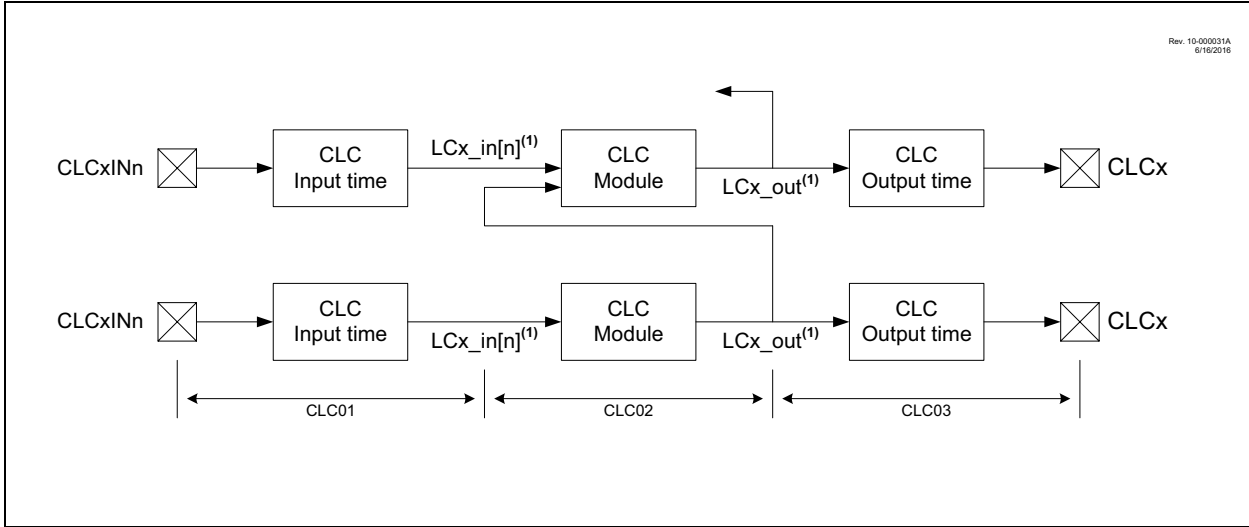

TABLE 37-20: CONFIGURABLE LOGIC CELL (CLC) CHARACTERISTICS

Standard Operating Conditions (unless otherwise stated)
 Operating temperature $-40^{\circ}\text{C} \leq T_A \leq +125^{\circ}\text{C}$

Param. No.	Sym.	Characteristic	Min.	Typ†	Max.	Units	Conditions
CLC01*	TCLCIN	CLC input time	—	7	OS17	ns	(Note 1)
CLC02*	TCLC	CLC module input to output propagation time	—	24 12	— —	ns ns	$V_{DD} = 1.8\text{V}$ $V_{DD} > 3.6\text{V}$
CLC03*	TCLCOUT	CLC output time	—	Rise Time	OS18	—	(Note 1)
		Fall Time		OS19	—	(Note 1)	
CLC04*	FCLCMAX	CLC maximum switching frequency	—	32	Fosc	MHz	

* These parameters are characterized but not tested.

† Data in "Typ" column is at 3.0V, 25°C unless otherwise stated. These parameters are for design guidance only and are not tested.

Note 1: See Table 37-10 for OS17, OS18 and OS19 rise and fall times.

PIC16(L)F18856/76

FIGURE 37-15: EUSART SYNCHRONOUS TRANSMISSION (MASTER/SLAVE) TIMING

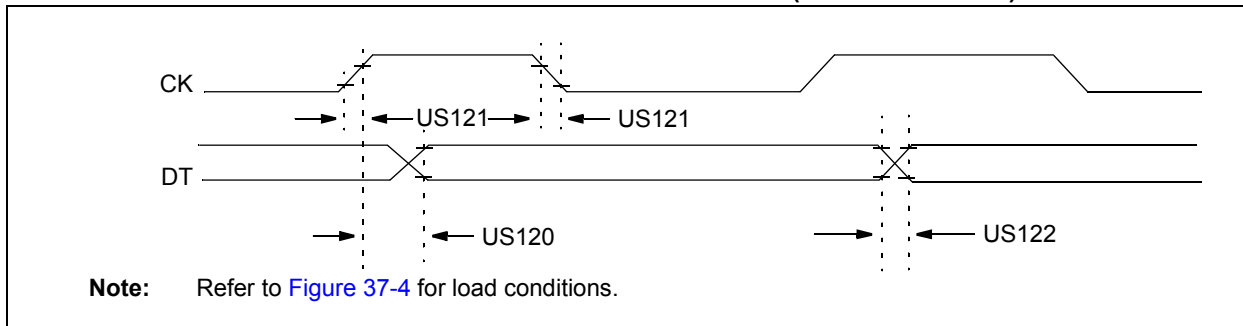

TABLE 37-21: EUSART SYNCHRONOUS TRANSMISSION REQUIREMENTS

Standard Operating Conditions (unless otherwise stated)						
Param. No.	Symbol	Characteristic	Min.	Max.	Units	Conditions
US120	TckH2DTV	SYNC XMIT (Master and Slave) Clock high to data-out valid	—	80	ns	$3.0V \leq V_{DD} \leq 5.5V$
			—	100	ns	$1.8V \leq V_{DD} \leq 5.5V$
US121	TckRF	Clock out rise time and fall time (Master mode)	—	45	ns	$3.0V \leq V_{DD} \leq 5.5V$
			—	50	ns	$1.8V \leq V_{DD} \leq 5.5V$
US122	TDTRF	Data-out rise time and fall time	—	45	ns	$3.0V \leq V_{DD} \leq 5.5V$
			—	50	ns	$1.8V \leq V_{DD} \leq 5.5V$

FIGURE 37-16: EUSART SYNCHRONOUS RECEIVE (MASTER/SLAVE) TIMING

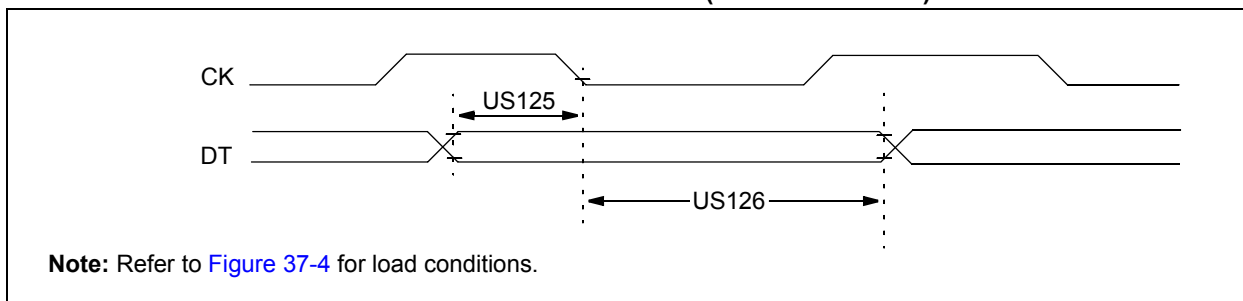

TABLE 37-22: EUSART SYNCHRONOUS RECEIVE REQUIREMENTS

Standard Operating Conditions (unless otherwise stated)						
Param. No.	Symbol	Characteristic	Min.	Max.	Units	Conditions
US125	TDTV2CKL	SYNC RCV (Master and Slave) Data-setup before CK ↓ (DT hold time)	10	—	ns	
US126	TckL2DTL	Data-hold after CK ↓ (DT hold time)	15	—	ns	

PIC16(L)F18856/76

FIGURE 37-17: SPI MASTER MODE TIMING (CKE = 0, SMP = 0)

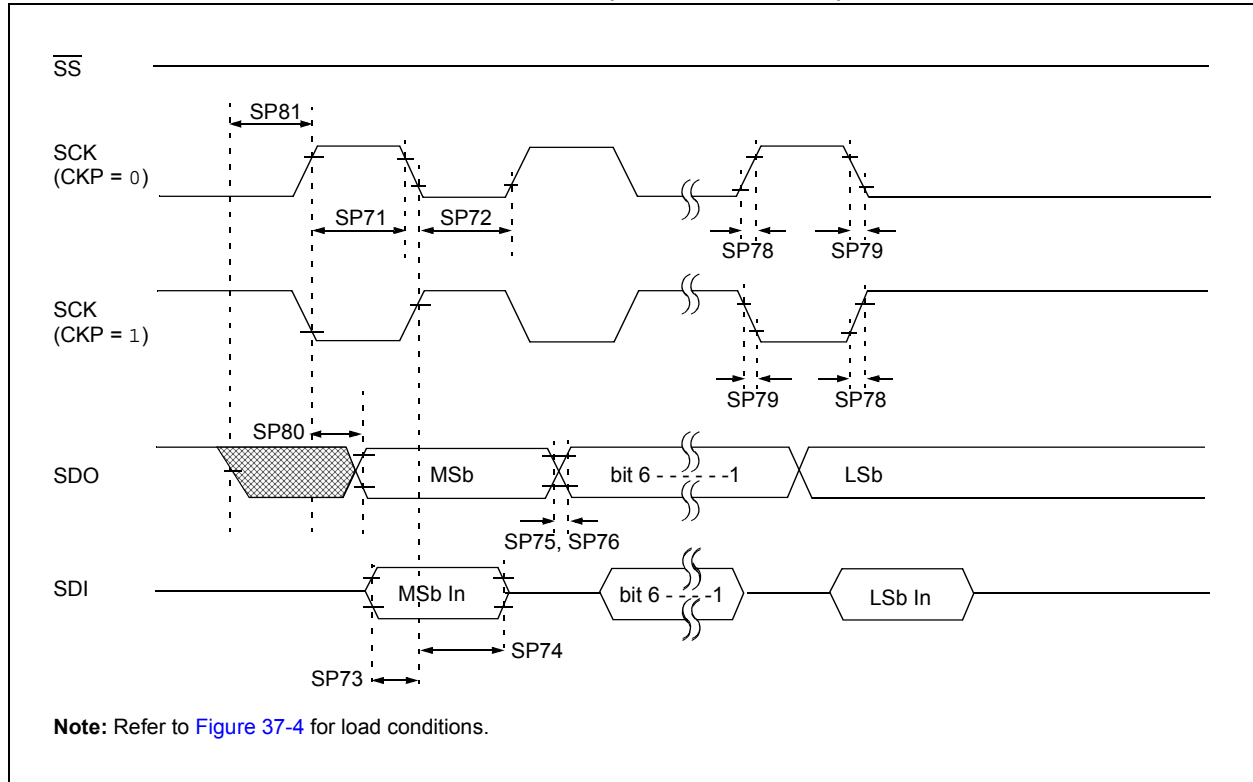
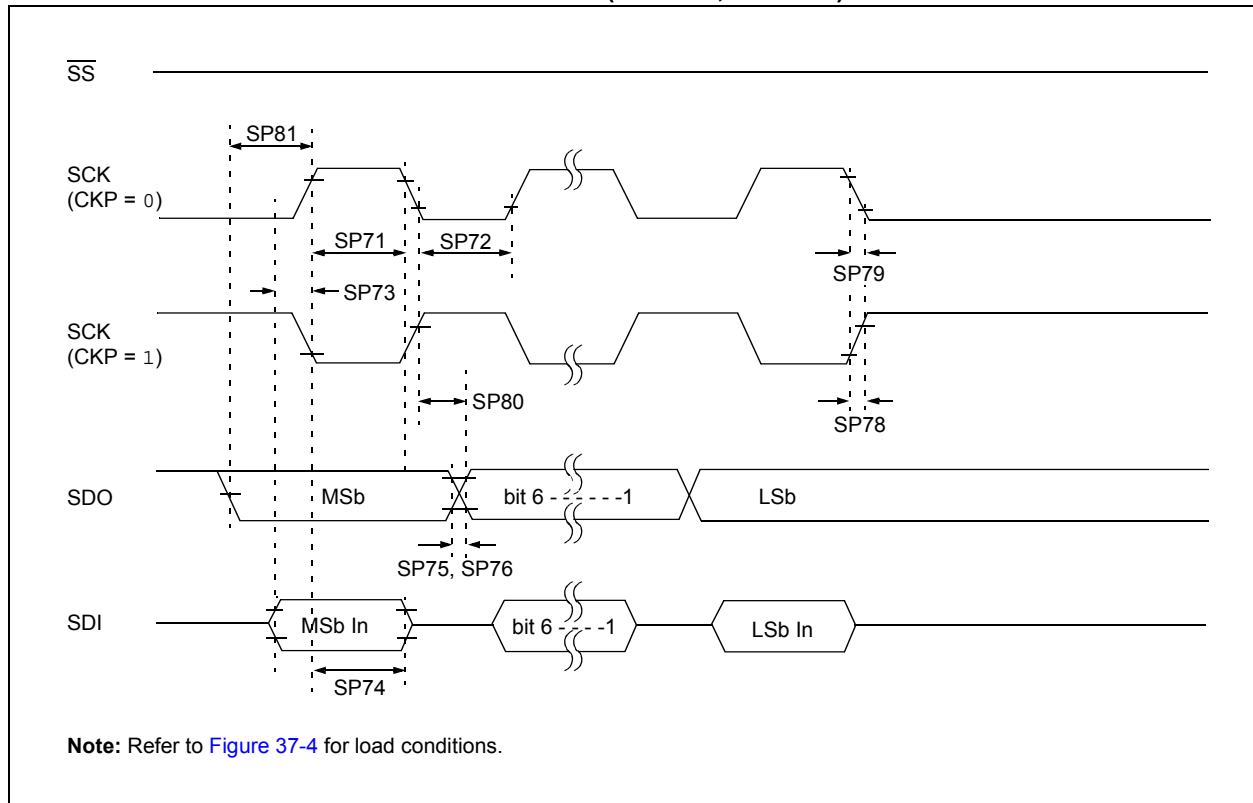

FIGURE 37-18: SPI MASTER MODE TIMING (CKE = 1, SMP = 1)



PIC16(L)F18856/76

FIGURE 37-19: SPI SLAVE MODE TIMING (CKE = 0)

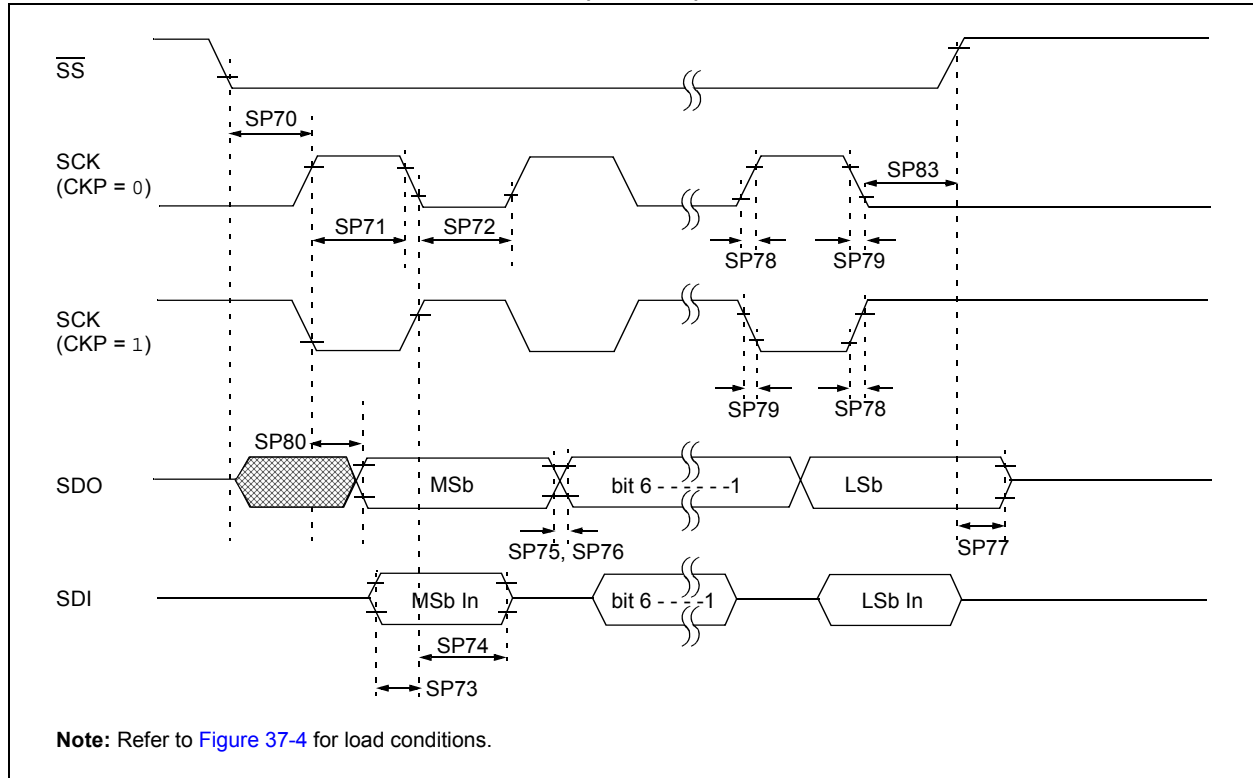
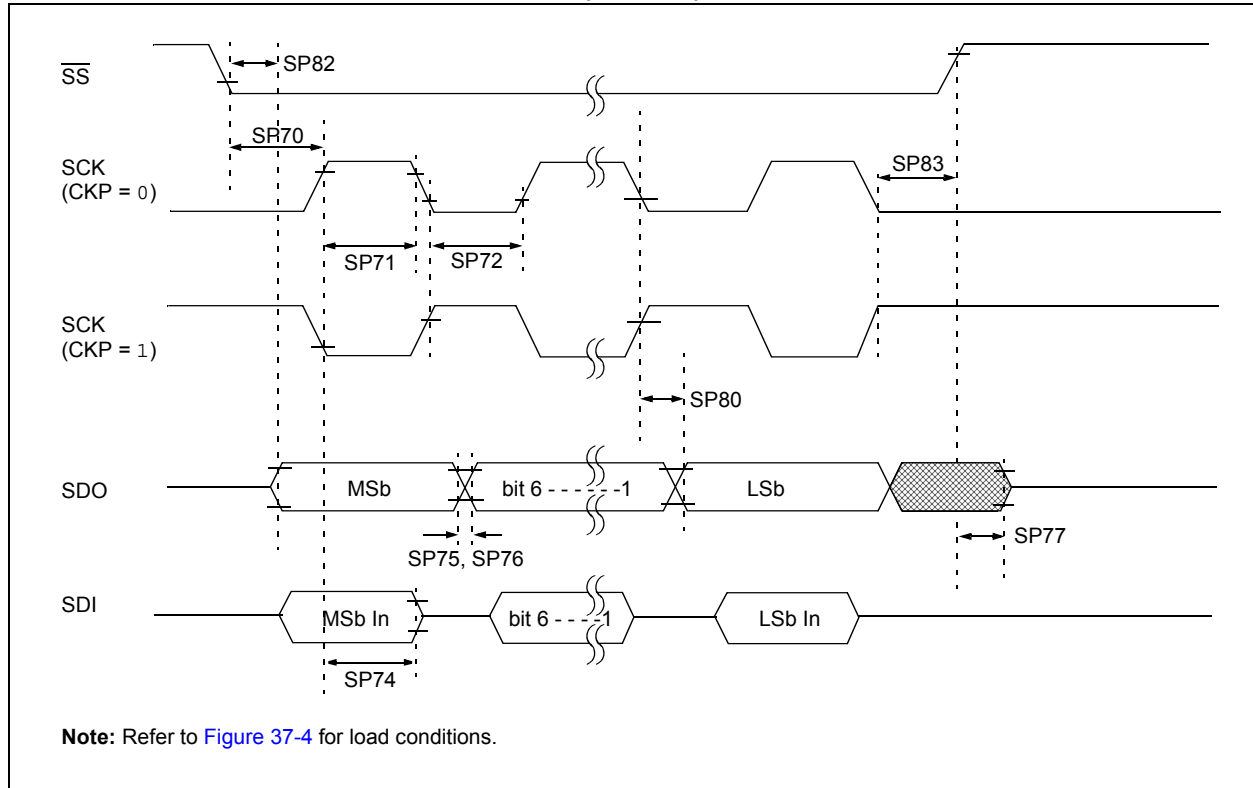

FIGURE 37-20: SPI SLAVE MODE TIMING (CKE = 1)



PIC16(L)F18856/76

TABLE 37-23: SPI MODE REQUIREMENTS

Standard Operating Conditions (unless otherwise stated)							
Param. No.	Symbol	Characteristic	Min.	Typ†	Max.	Units	Conditions
SP70*	TssL2scH, TssL2scL	$\overline{SS}\downarrow$ to SCK \downarrow or SCK \uparrow input	2.25*Tcy	—	—	ns	
SP71*	TscH	SCK input high time (Slave mode)	Tcy + 20	—	—	ns	
SP72*	TscL	SCK input low time (Slave mode)	Tcy + 20	—	—	ns	
SP73*	TdIV2scH, TdIV2scL	Setup time of SDI data input to SCK edge	100	—	—	ns	
SP74*	Tsch2diL, TscL2diL	Hold time of SDI data input to SCK edge	100	—	—	ns	
SP75*	TdoR	SDO data output rise time	—	10	25	ns	3.0V ≤ VDD ≤ 5.5V
			—	25	50	ns	1.8V ≤ VDD ≤ 5.5V
SP76*	TdoF	SDO data output fall time	—	10	25	ns	
SP77*	TssH2boZ	$\overline{SS}\uparrow$ to SDO output high-impedance	10	—	50	ns	
SP78*	TscR	SCK output rise time (Master mode)	—	10	25	ns	3.0V ≤ VDD ≤ 5.5V
			—	25	50	ns	1.8V ≤ VDD ≤ 5.5V
SP79*	TscF	SCK output fall time (Master mode)	—	10	25	ns	
SP80*	Tsch2doV, TscL2doV	SDO data output valid after SCK edge	—	—	50	ns	3.0V ≤ VDD ≤ 5.5V
			—	—	145	ns	1.8V ≤ VDD ≤ 5.5V
SP81*	TdoV2scH, TdoV2scL	SDO data output setup to SCK edge	1 Tcy	—	—	ns	
SP82*	TssL2doV	SDO data output valid after $\overline{SS}\downarrow$ edge	—	—	50	ns	
SP83*	Tsch2ssH, TscL2ssH	$\overline{SS}\uparrow$ after SCK edge	1.5 Tcy + 40	—	—	ns	

* These parameters are characterized but not tested.

† Data in "Typ" column is at 3.0V, 25°C unless otherwise stated. These parameters are for design guidance only and are not tested.

PIC16(L)F18856/76

FIGURE 37-21: I²C BUS START/STOP BITS TIMING

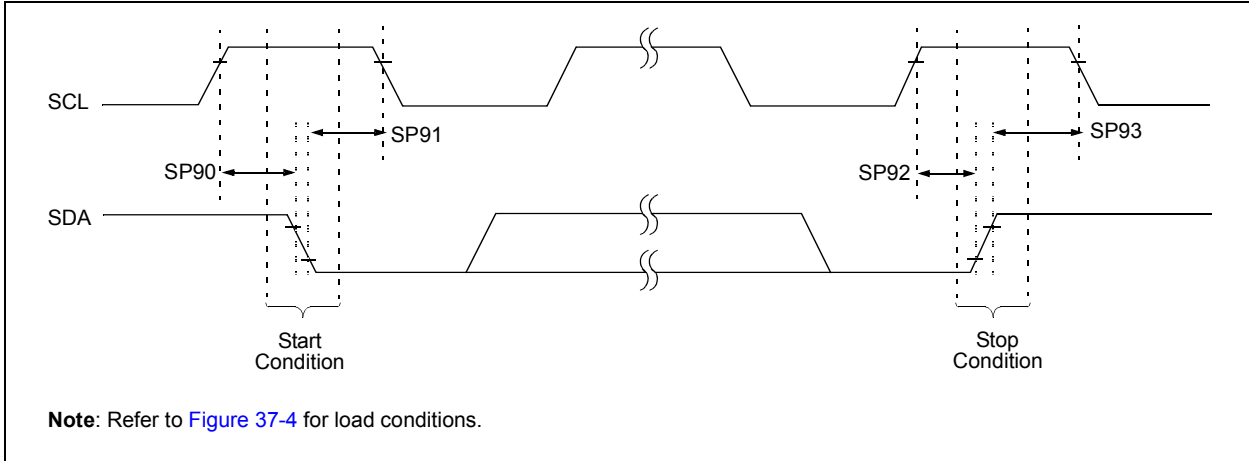
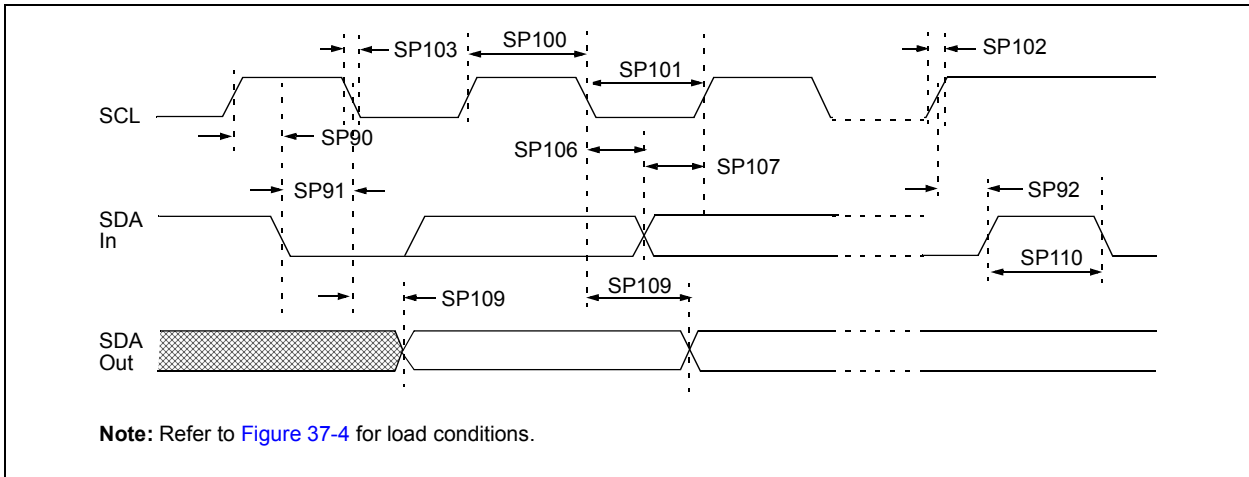

TABLE 37-24: I²C BUS START/STOP BITS REQUIREMENTS

Standard Operating Conditions (unless otherwise stated)								
Param. No.	Symbol	Characteristic		Min.	Typ	Max.	Units	Conditions
SP90*	TSU:STA	Start condition	100 kHz mode	4700	—	—	ns	Only relevant for Repeated Start condition
		Setup time	400 kHz mode	600	—	—		
SP91*	THD:STA	Start condition	100 kHz mode	4000	—	—	ns	After this period, the first clock pulse is generated
		Hold time	400 kHz mode	600	—	—		
SP92*	TSU:STO	Stop condition	100 kHz mode	4700	—	—	ns	
		Setup time	400 kHz mode	600	—	—		
SP93	THD:STO	Stop condition	100 kHz mode	4000	—	—	ns	
		Hold time	400 kHz mode	600	—	—		

* These parameters are characterized but not tested.

FIGURE 37-22: I²C BUS DATA TIMING



PIC16(L)F18856/76

TABLE 37-25: I²C BUS DATA REQUIREMENTS

Standard Operating Conditions (unless otherwise stated)							
Param. No.	Symbol	Characteristic		Min.	Max.	Units	Conditions
SP100*	THIGH	Clock high time	100 kHz mode	4.0	—	μs	Device must operate at a minimum of 1.5 MHz
			400 kHz mode	0.6	—	μs	Device must operate at a minimum of 10 MHz
			SSP module	1.5T _{CY}	—		
SP101*	TLOW	Clock low time	100 kHz mode	4.7	—	μs	Device must operate at a minimum of 1.5 MHz
			400 kHz mode	1.3	—	μs	Device must operate at a minimum of 10 MHz
			SSP module	1.5T _{CY}	—		
SP102*	TR	SDA and SCL rise time	100 kHz mode	—	1000	ns	
			400 kHz mode	20 + 0.1C _B	300	ns	C _B is specified to be from 10-400 pF
SP103*	TF	SDA and SCL fall time	100 kHz mode	—	250	ns	
			400 kHz mode	20 + 0.1C _B	250	ns	C _B is specified to be from 10-400 pF
SP106*	THD:DAT	Data input hold time	100 kHz mode	0	—	ns	
			400 kHz mode	0	0.9	μs	
SP107*	TSU:DAT	Data input setup time	100 kHz mode	250	—	ns	(Note 2)
			400 kHz mode	100	—	ns	
SP109*	TAA	Output valid from clock	100 kHz mode	—	3500	ns	(Note 1)
			400 kHz mode	—	—	ns	
SP110*	TBUF	Bus free time	100 kHz mode	4.7	—	μs	Time the bus must be free before a new transmission can start
			400 kHz mode	1.3	—	μs	
SP111	C _B	Bus capacitive loading		—	400	pF	

* These parameters are characterized but not tested.

- Note 1:** As a transmitter, the device must provide this internal minimum delay time to bridge the undefined region (min. 300 ns) of the falling edge of SCL to avoid unintended generation of Start or Stop conditions.
- 2:** A Fast mode (400 kHz) I²C bus device can be used in a Standard mode (100 kHz) I²C bus system, but the requirement TSU:DAT ≥ 250 ns must then be met. This will automatically be the case if the device does not stretch the low period of the SCL signal. If such a device does stretch the low period of the SCL signal, it must output the next data bit to the SDA line TR max. + TSU:DAT = 1000 + 250 = 1250 ns (according to the Standard mode I²C bus specification), before the SCL line is released.

PIC16(L)F18856/76

38.0 DC AND AC CHARACTERISTICS GRAPHS AND CHARTS

The graphs and tables provided in this section are for **design guidance** and are **not tested**.

In some graphs or tables, the data presented are **outside specified operating range** (i.e., outside specified V_{DD} range). This is for **information only** and devices are ensured to operate properly only within the specified range.

Unless otherwise noted, all graphs apply to both the L and LF devices.

<p>Note: The graphs and tables provided following this note are a statistical summary based on a limited number of samples and are provided for informational purposes only. The performance characteristics listed herein are not tested or guaranteed. In some graphs or tables, the data presented may be outside the specified operating range (e.g., outside specified power supply range) and therefore, outside the warranted range.</p>
--

“Typical” represents the mean of the distribution at 25°C. **“Maximum”, “Max.”, “Minimum” or “Min.”** represents (mean + 3σ) or (mean - 3σ) respectively, where σ is a standard deviation, over each temperature range.

PIC16(L)F18856/76

Note: Unless otherwise noted, $V_{IN} = 5V$, $F_{OSC} = 300\text{ kHz}$, $C_{IN} = 0.1\ \mu\text{F}$, $T_A = 25^\circ\text{C}$.

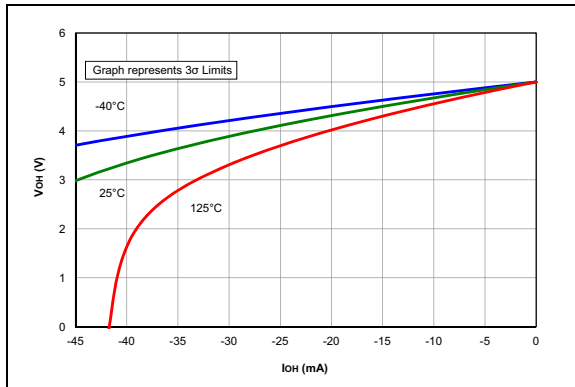

FIGURE 38-1: V_{OH} vs. I_{OH} Over Temperature, $V_{DD} = 5.0V$, PIC16F18856/76 Only.

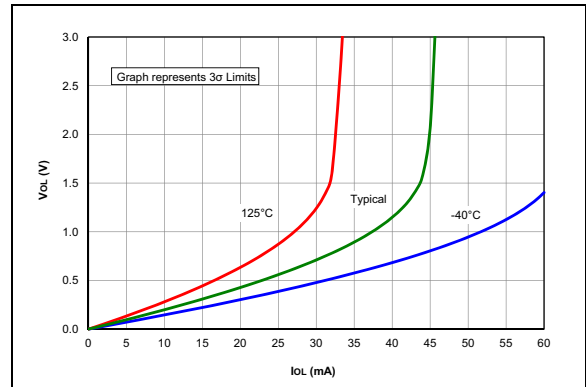

FIGURE 38-4: V_{OL} vs. I_{OL} Over Temperature, $V_{DD} = 3.0V$.

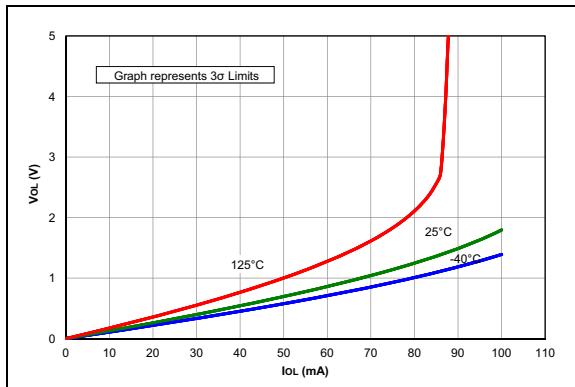

FIGURE 38-2: V_{OL} vs. I_{OL} Over Temperature, $V_{DD} = 5.0V$, PIC16F18856/76 Only.

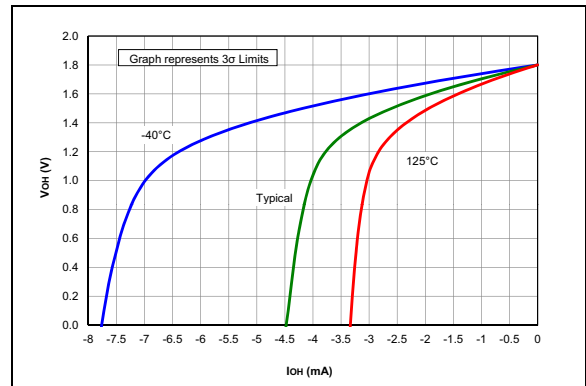

FIGURE 38-5: V_{OH} vs. I_{OH} Over Temperature, $V_{DD} = 1.8V$, PIC16LF18856/76 Only.

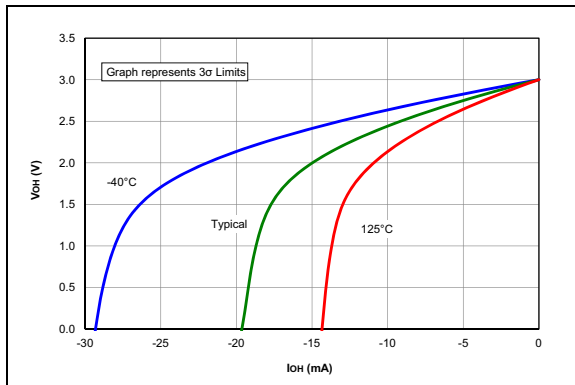

FIGURE 38-3: V_{OH} vs. I_{OH} Over Temperature, $V_{DD} = 3.0V$.

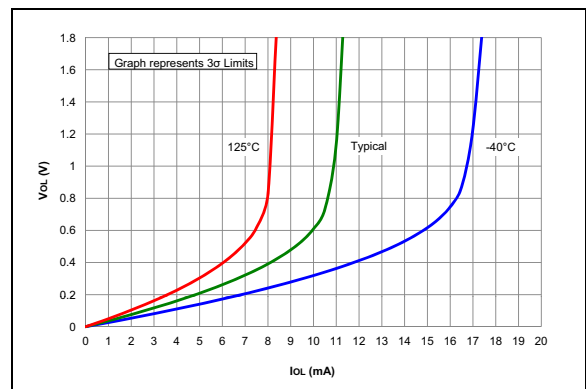

FIGURE 38-6: V_{OL} vs. I_{OL} Over Temperature, $V_{DD} = 1.8V$, PIC16LF18856/76 Only.

PIC16(L)F18856/76

Note: Unless otherwise noted, $V_{IN} = 5V$, $F_{OSC} = 300\text{ kHz}$, $C_{IN} = 0.1\ \mu\text{F}$, $T_A = 25^\circ\text{C}$.

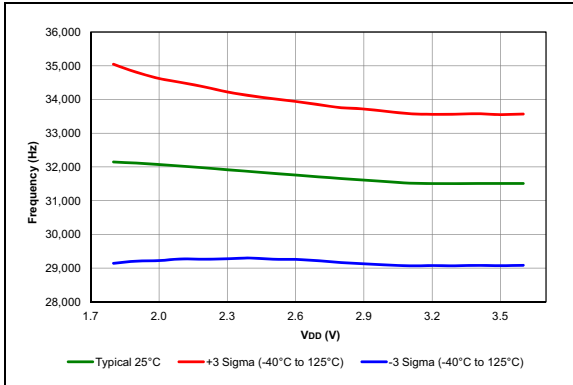

FIGURE 38-7: LFINTOSC Frequency, PIC16LF18856/76 Only.

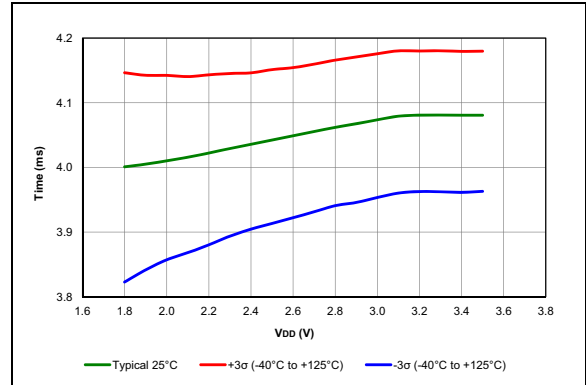

FIGURE 38-10: WDT Time-Out Period, PIC16LF18856/76 Only.

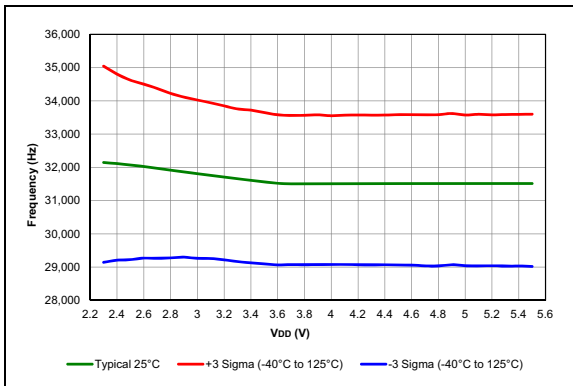

FIGURE 38-8: LFINTOSC Frequency, PIC16F18856/76 Only.

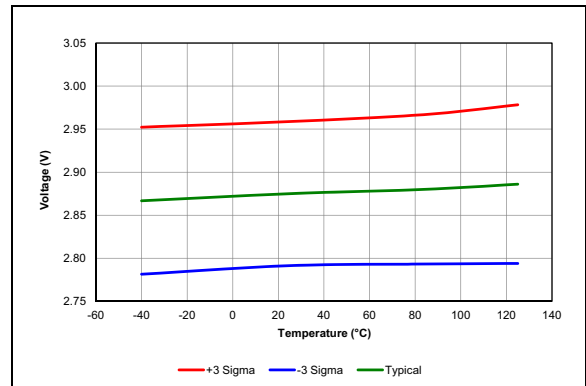

FIGURE 38-11: Brown-Out Reset Voltage, Trip Point (BORV = 00).

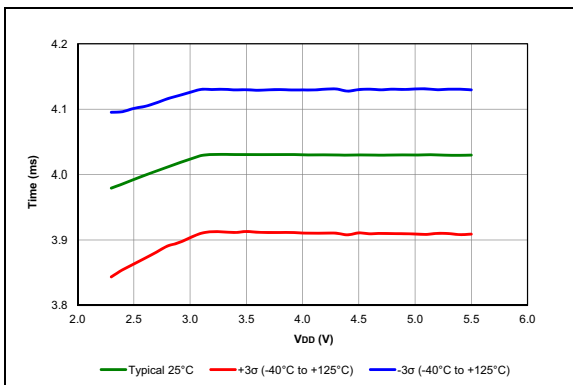

FIGURE 38-9: WDT Time-Out Period, PIC16F18856/76 Only.

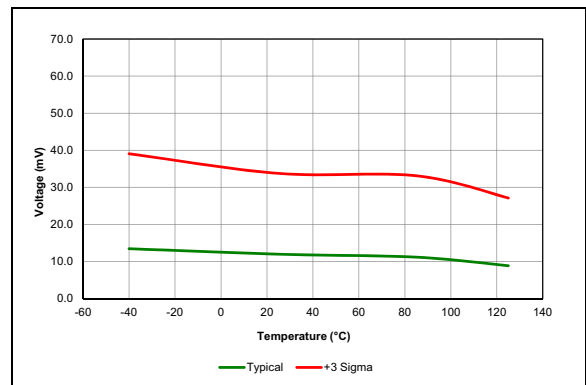

FIGURE 38-12: Brown-Out Reset Hysteresis, Low Trip Point (BORV = 00).

PIC16(L)F18856/76

Note: Unless otherwise noted, $V_{IN} = 5V$, $F_{OSC} = 300\text{ kHz}$, $C_{IN} = 0.1\ \mu F$, $T_A = 25^\circ C$.

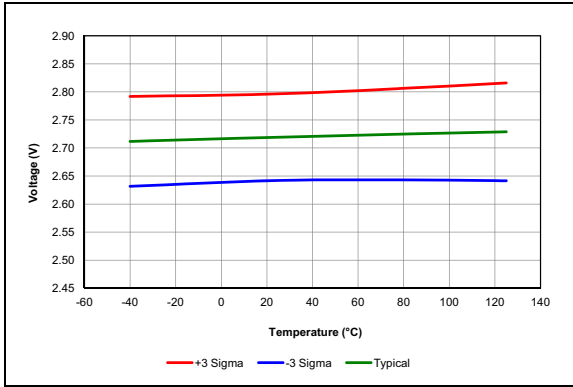

FIGURE 38-13: Brown-Out Reset Voltage, Trip Point (BORV = 01).

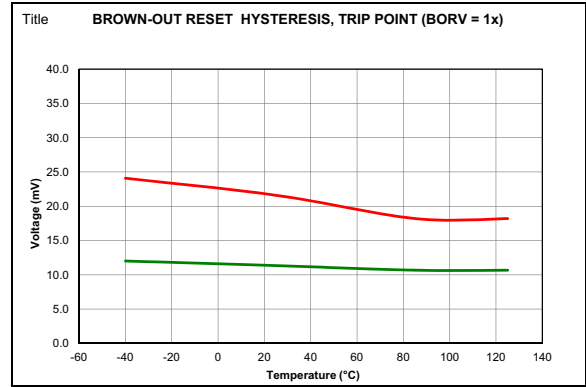

FIGURE 38-16: Brown-Out Reset Hysteresis, Trip Point (BORV = 1x).

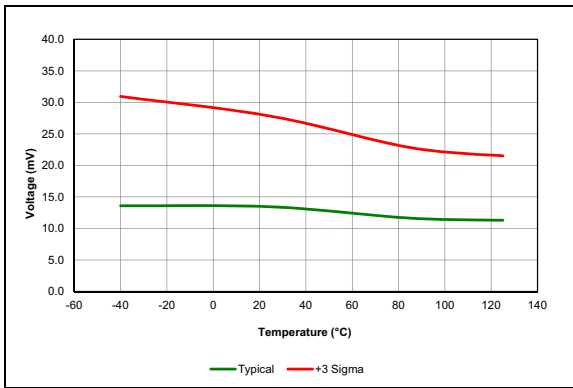

FIGURE 38-14: Brown-Out Reset Hysteresis, Trip Point (BORV = 01).

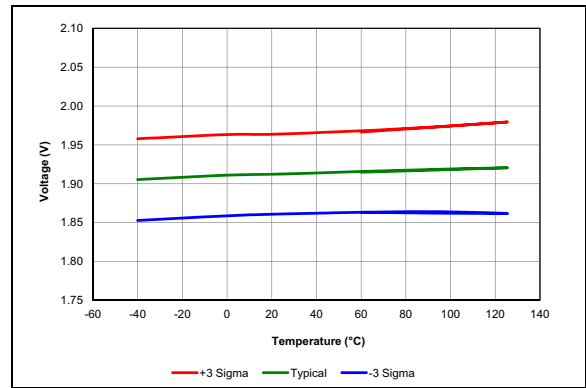

FIGURE 38-17: Brown-Out Reset Voltage, Trip Point (BORV = 11).

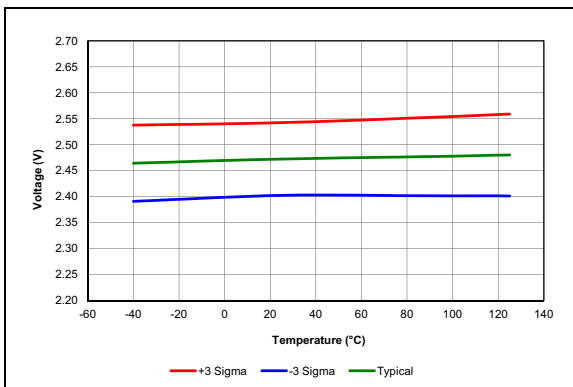

FIGURE 38-15: Brown-Out Reset Voltage, Trip Point (BORV = 1x).

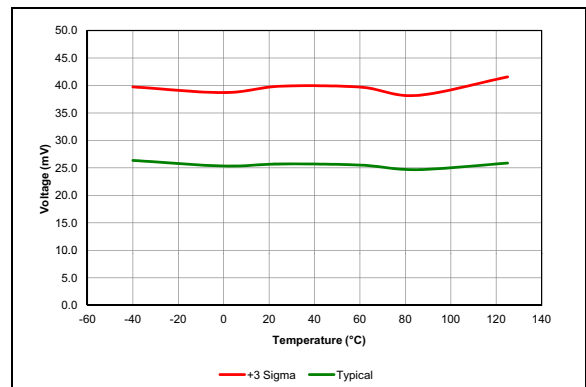

FIGURE 38-18: Brown-Out Reset Hysteresis, Trip Point (BORV = 11), PIC16LF18856/76 Only.

PIC16(L)F18856/76

Note: Unless otherwise noted, $V_{IN} = 5V$, $F_{OSC} = 300\text{ kHz}$, $C_{IN} = 0.1\ \mu F$, $T_A = 25^\circ C$.

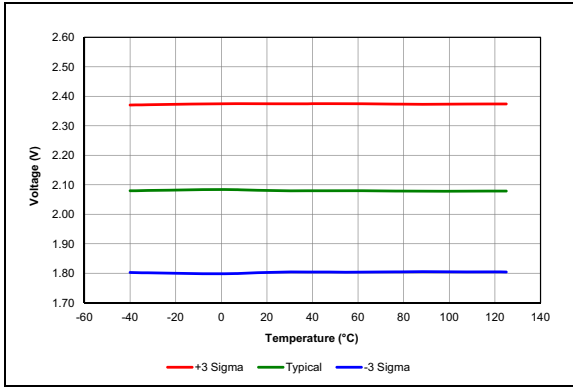

FIGURE 38-19: LPBOR Reset Voltage, PIC16LF18856/76 Only.

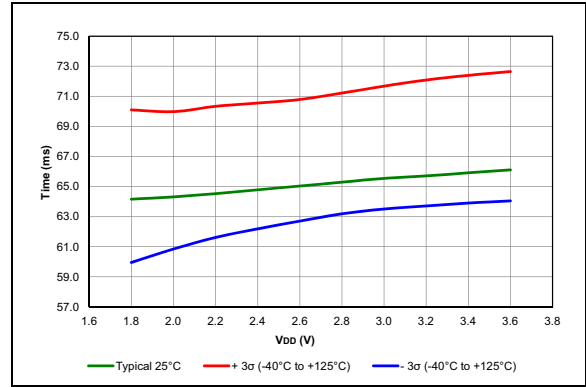

FIGURE 38-22: PWRT Period, PIC16LF18856/76 Only.

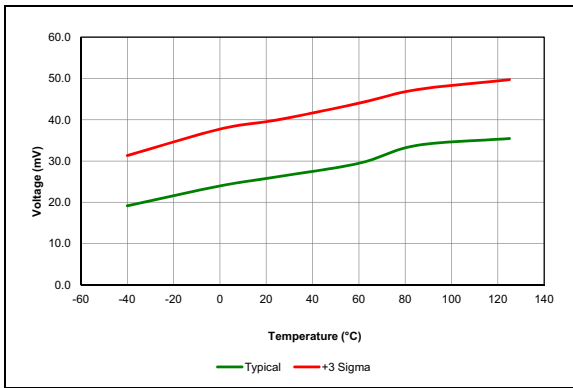

FIGURE 38-20: LPBOR Reset Hysteresis, PIC16LF18856/76 Only.

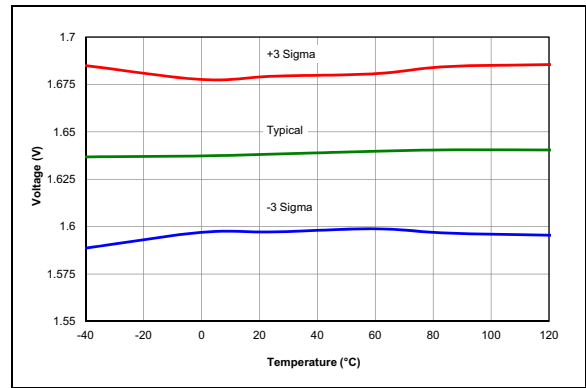

FIGURE 38-23: POR Release Voltage.

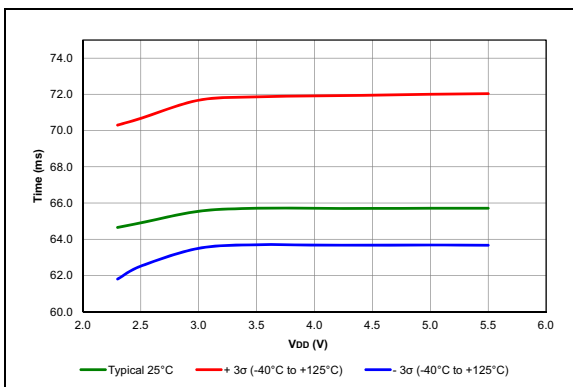

FIGURE 38-21: PWRT Period, PIC16F18856/76 Only.

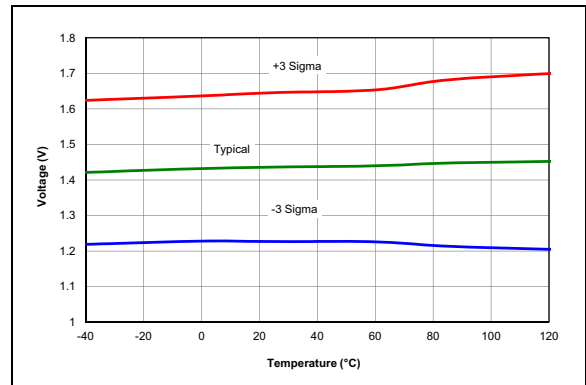

FIGURE 38-24: POR Rearm Voltage, $V_{REGPM1} = 0$, PIC16F18856/76 Only.

PIC16(L)F18856/76

Note: Unless otherwise noted, $V_{IN} = 5V$, $F_{OSC} = 300\text{ kHz}$, $C_{IN} = 0.1\ \mu\text{F}$, $T_A = 25^\circ\text{C}$.

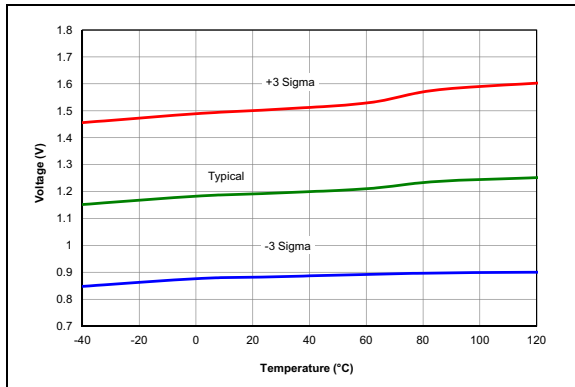

FIGURE 38-25: POR Rearm Voltage, $V_{REGPM1} = 1$, PIC16F18856/76 Only.

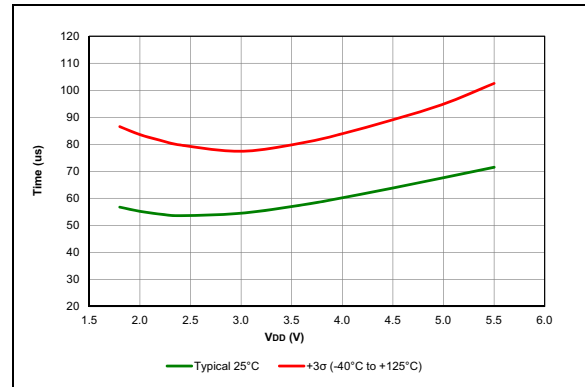

FIGURE 38-28: Wake From Sleep, $V_{REGPM} = 1$, $HFINTOSC = 4\text{ MHz}$, PIC16F18856/76 Only.

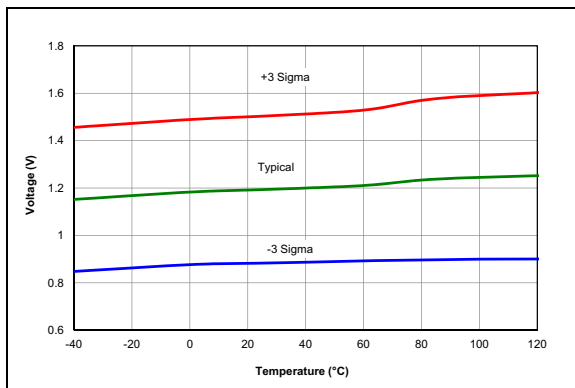

FIGURE 38-26: POR Rearm Voltage, Normal Power Mode, PIC16LF18856/76 Only.

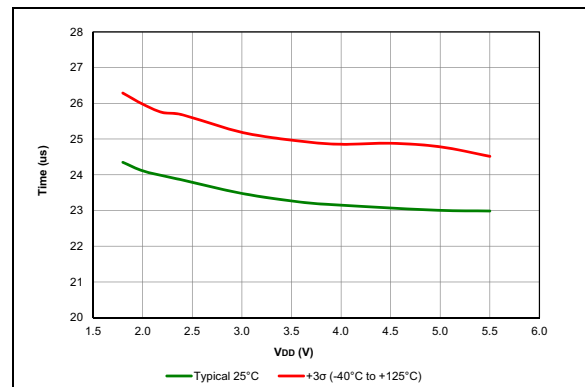

FIGURE 38-29: Wake From Sleep, $V_{REGPM} = 0$, $HFINTOSC = 16\text{ MHz}$, PIC16F18856/76 Only.

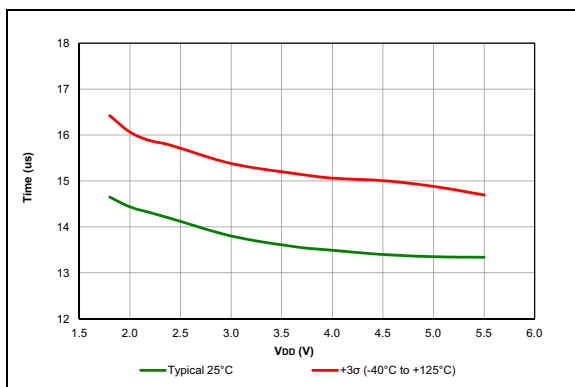

FIGURE 38-27: Wake From Sleep, $V_{REGPM} = 0$, $HFINTOSC = 4\text{ MHz}$, PIC16F18856/76 Only.

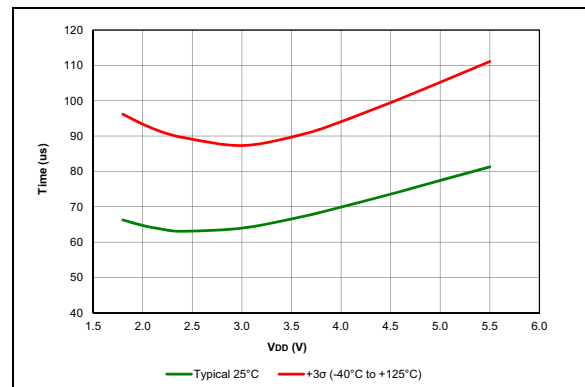

FIGURE 38-30: Wake From Sleep, $V_{REGPM} = 1$, $HFINTOSC = 16\text{ MHz}$, PIC16F18856/76 Only.

PIC16(L)F18856/76

Note: Unless otherwise noted, $V_{IN} = 5V$, $F_{OSC} = 300\text{ kHz}$, $C_{IN} = 0.1\ \mu\text{F}$, $T_A = 25^\circ\text{C}$.

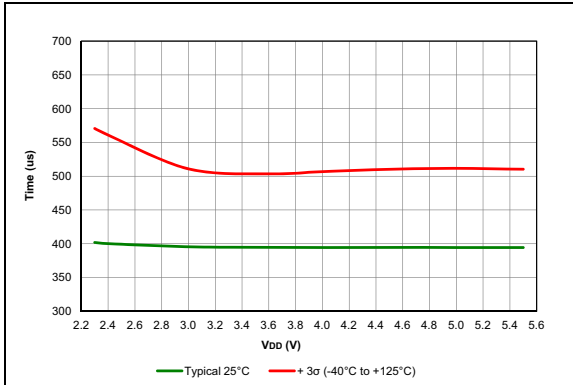

FIGURE 38-31: Wake From Sleep, $V_{REGPM} = 1$, $LFINTOSC$, PIC16F18856/76 Only.

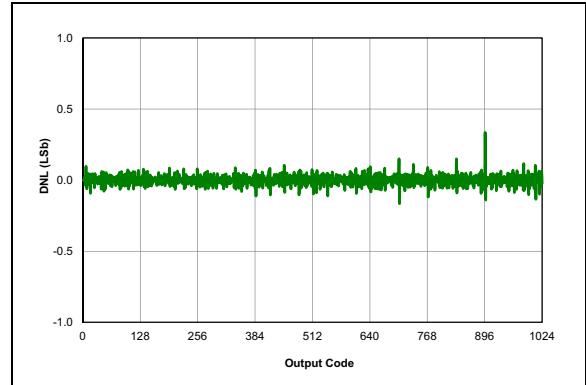

FIGURE 38-34: ADC, DNL, $V_{DD} = 3.0V$, $T_{AD} = 4\ \mu\text{S}$, 25°C .

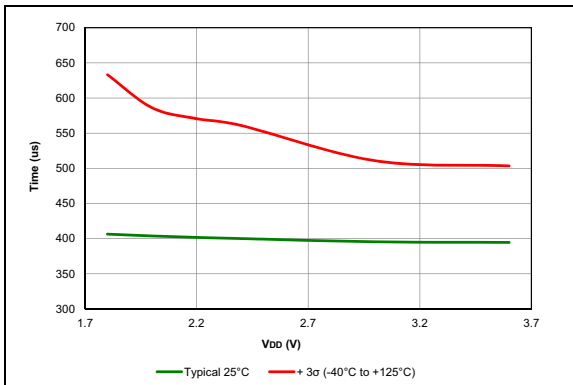

FIGURE 38-32: Wake From Sleep, $LFINTOSC$, PIC16LF18856/76 Only.

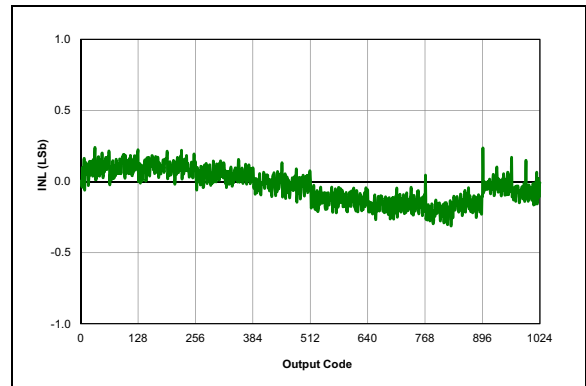

FIGURE 38-35: ADC, INL, $V_{DD} = 3.0V$, $T_{AD} = 1\ \mu\text{S}$, 25°C .

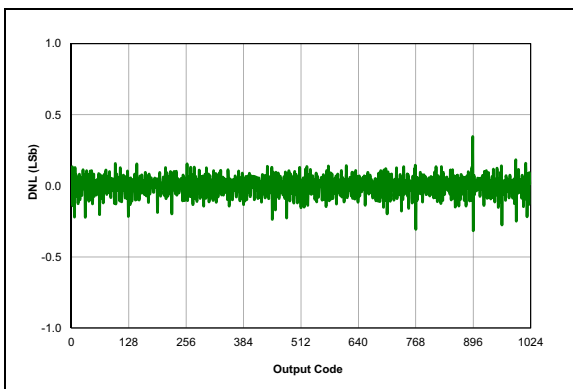

FIGURE 38-33: ADC, DNL, $V_{DD} = 3.0V$, $T_{AD} = 1\ \mu\text{S}$, 25°C .

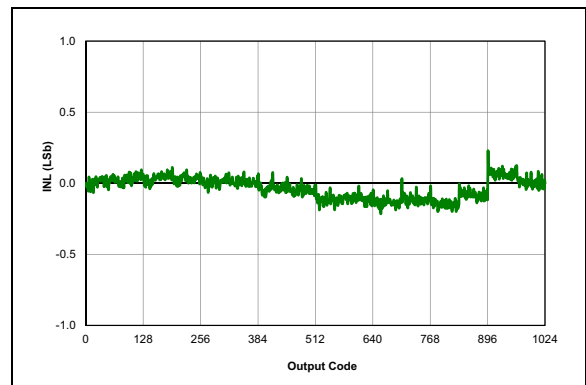

FIGURE 38-36: ADC, INL, $V_{DD} = 3.0V$, $T_{AD} = 4\ \mu\text{S}$, 25°C .

PIC16(L)F18856/76

Note: Unless otherwise noted, $V_{IN} = 5V$, $F_{OSC} = 300\text{ kHz}$, $C_{IN} = 0.1\ \mu F$, $T_A = 25^\circ C$.

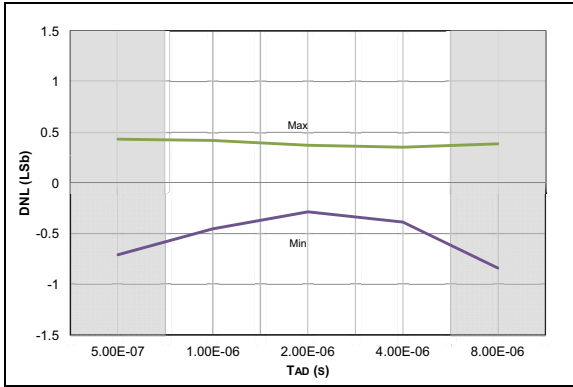

FIGURE 38-37: ADC 10-bit Mode, Single-Ended DNL, $V_{DD} = 3.0V$, $V_{REF} = 3.0V$.

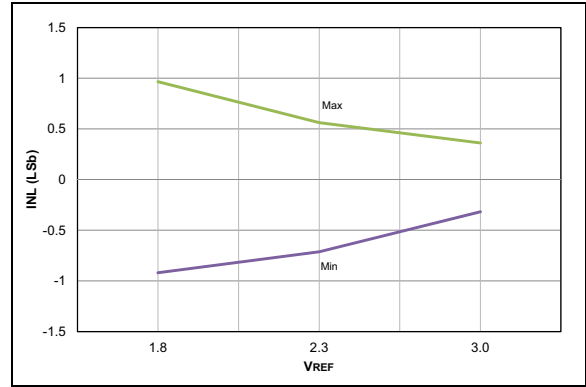

FIGURE 38-40: ADC 10-bit Mode, Single-Ended INL, $V_{DD} = 3.0V$, $T_{AD} = 1\ \mu S$.

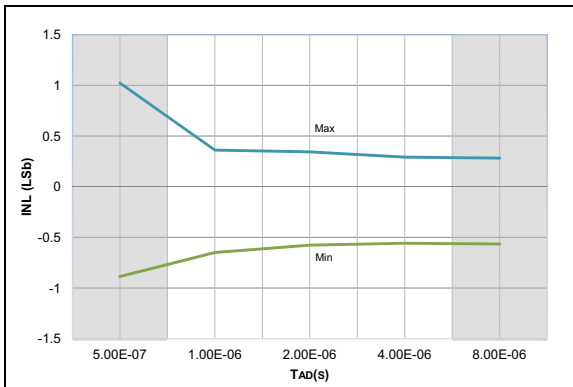

FIGURE 38-38: ADC 10-bit Mode, Single-Ended INL, $V_{DD} = 3.0V$, $V_{REF} = 3.0V$.

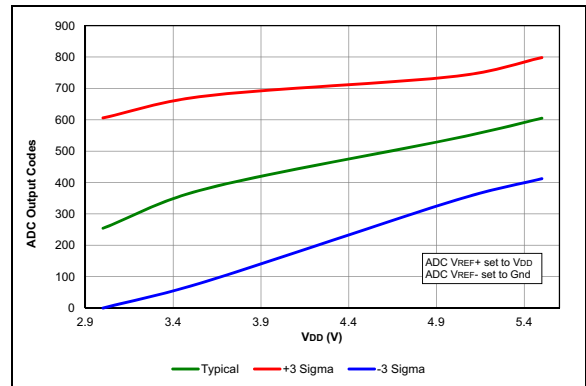

FIGURE 38-41: Temp. Indicator Initial Offset, High Range, Temp. = $20^\circ C$, PIC16F18856/76 Only.

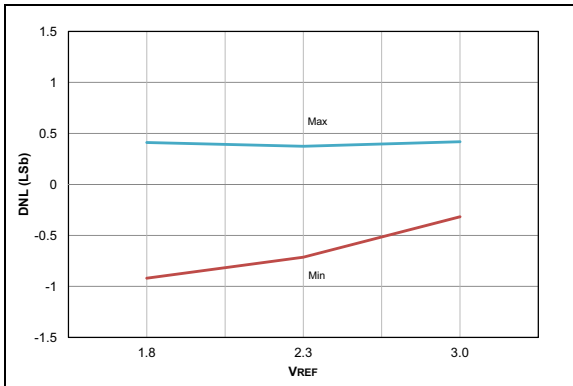

FIGURE 38-39: ADC 10-bit Mode, Single-Ended DNL, $V_{DD} = 3.0V$, $T_{AD} = 1\ \mu S$.

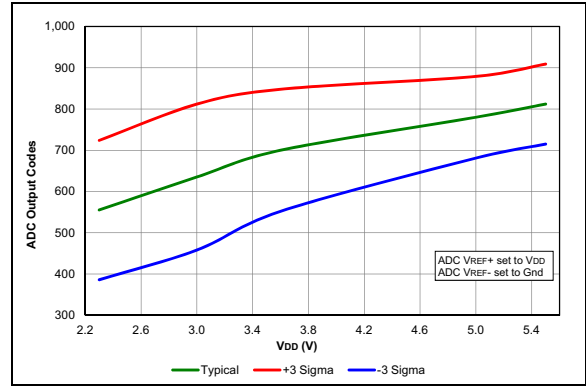

FIGURE 38-42: Temp. Indicator Initial Offset, Low Range, Temp. = $20^\circ C$, PIC16F18856/76 Only.

PIC16(L)F18856/76

Note: Unless otherwise noted, $V_{IN} = 5V$, $F_{OSC} = 300\text{ kHz}$, $C_{IN} = 0.1\ \mu\text{F}$, $T_A = 25^\circ\text{C}$.

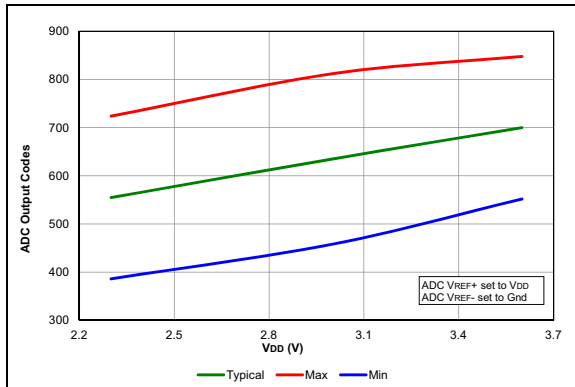

FIGURE 38-43: Temp. Indicator Initial Offset, Low Range, Temp. = 20°C , PIC16LF18856/76 Only.

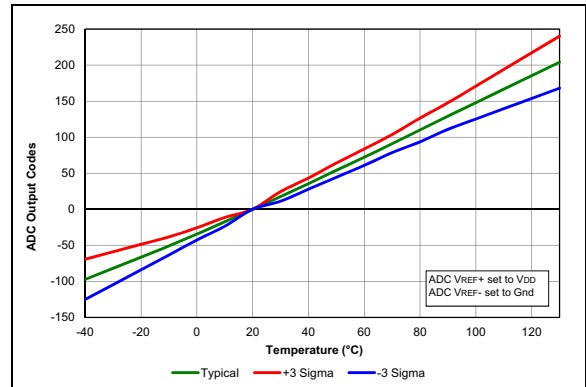

FIGURE 38-46: Temp. Indicator Slope Normalized to 20°C , High Range, $V_{DD} = 3.0V$.

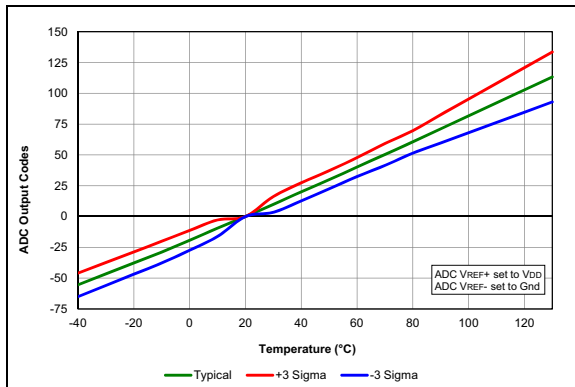

FIGURE 38-44: Temp. Indicator Slope Normalized to 20°C , High Range, $V_{DD} = 5.5V$, PIC16F18856/76 Only.

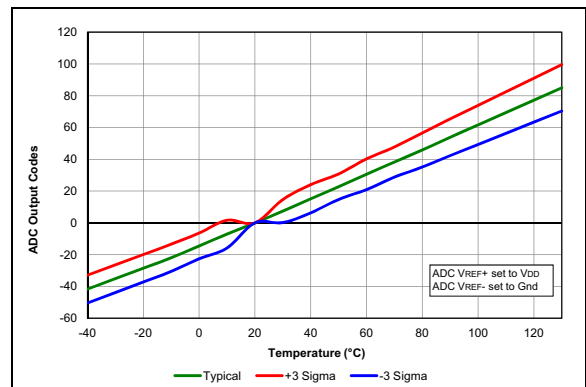

FIGURE 38-47: Temp. Indicator Slope Normalized to 20°C , Low Range, $V_{DD} = 3.6V$.

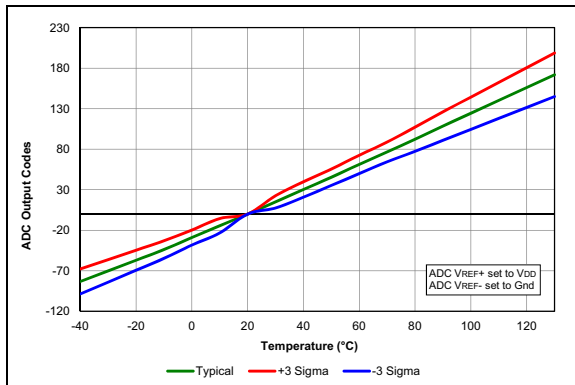

FIGURE 38-45: Temp. Indicator Slope Normalized to 20°C , High Range, $V_{DD} = 3.6V$.

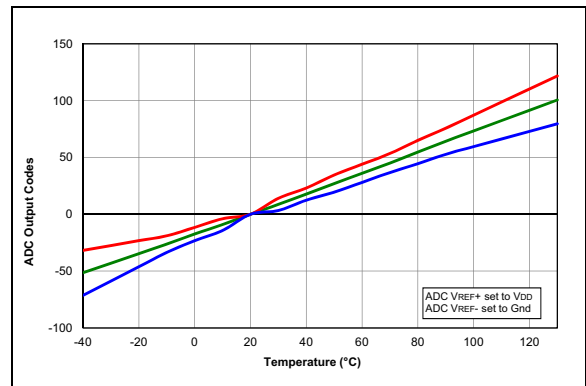

FIGURE 38-48: Temp. Indicator Slope Normalized to 20°C , Low Range, $V_{DD} = 3.0V$.

PIC16(L)F18856/76

Note: Unless otherwise noted, $V_{IN} = 5V$, $F_{OSC} = 300\text{ kHz}$, $C_{IN} = 0.1\ \mu\text{F}$, $T_A = 25^\circ\text{C}$.

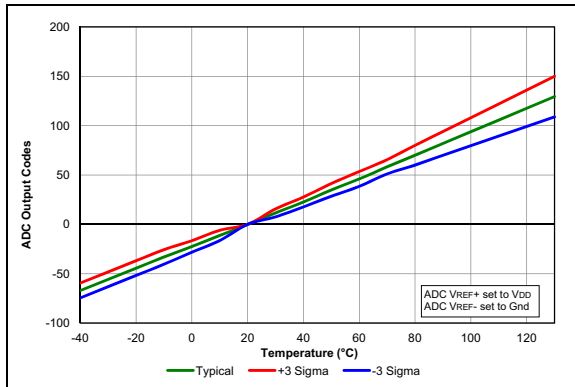

FIGURE 38-49: Temp. Indicator Slope Normalized to 20°C , Low Range, $V_{DD} = 2.3V$.

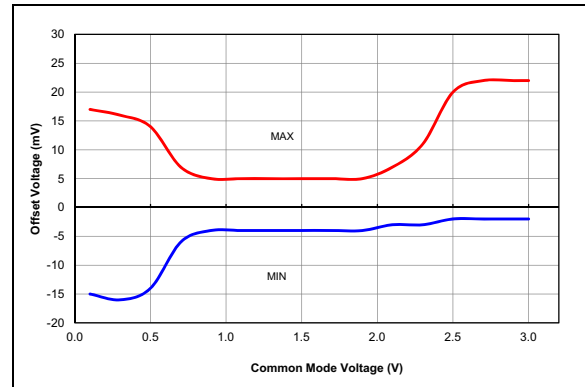

FIGURE 38-52: Comparator Offset, NP Mode ($CxSP = 1$), $V_{DD} = 3.0V$, Typical Measured Values from -40°C to 125°C .

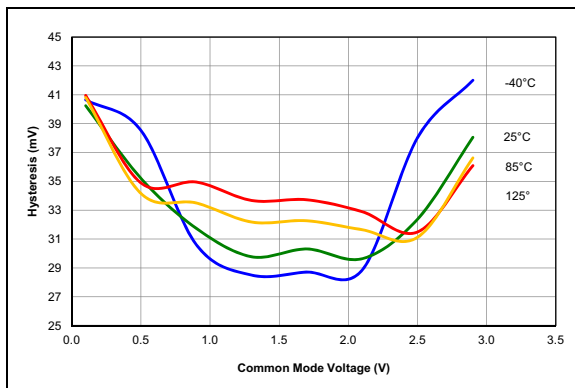

FIGURE 38-50: Comparator Hysteresis, NP Mode ($CxSP = 1$), $V_{DD} = 3.0V$, Typical Measured Values.

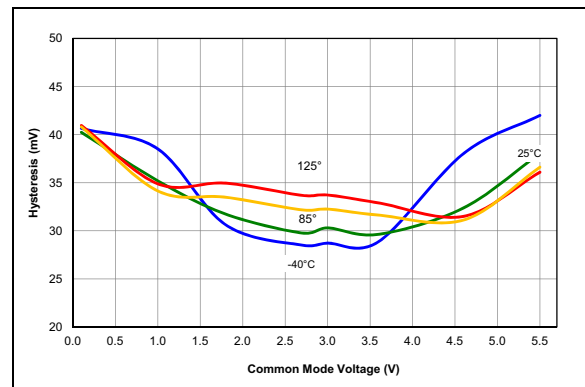

FIGURE 38-53: Comparator Hysteresis, NP Mode ($CxSP = 1$), $V_{DD} = 5.5V$, Typical Measured Values, PIC16F18856/76 Only.

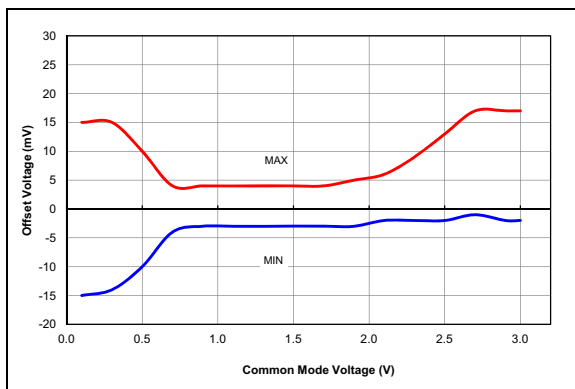

FIGURE 38-51: Comparator Offset, NP Mode ($CxSP = 1$), $V_{DD} = 3.0V$, Typical Measured Values at 25°C .

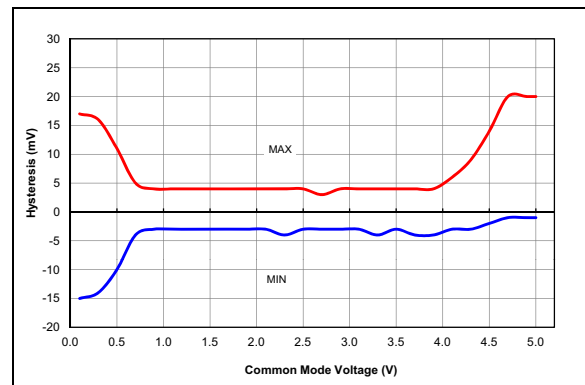

FIGURE 38-54: Comparator Offset, NP Mode ($CxSP = 1$), $V_{DD} = 5.0V$, Typical Measured Values at 25°C , PIC16F18856/76 Only.

PIC16(L)F18856/76

Note: Unless otherwise noted, $V_{IN} = 5V$, $F_{OSC} = 300\text{ kHz}$, $C_{IN} = 0.1\ \mu\text{F}$, $T_A = 25^\circ\text{C}$.

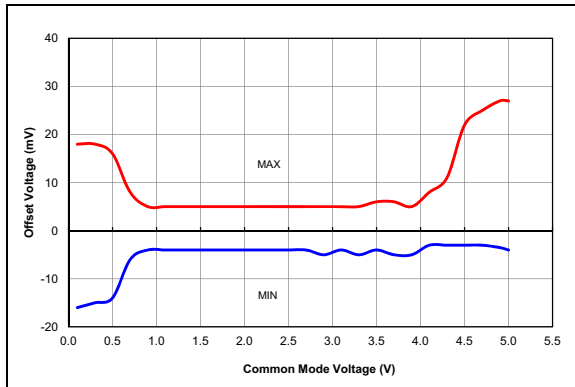

FIGURE 38-55: Comparator Offset, NP Mode ($CxSP = 1$), $V_{DD} = 5.5V$, Typical Measured Values from -40°C to 125°C , PIC16F18856/76 Only.

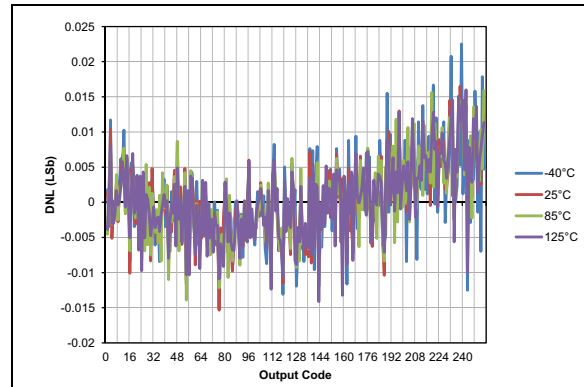

FIGURE 38-58: Typical DAC DNL Error, $V_{DD} = 3.0V$, $V_{REF} = \text{External } 3V$.

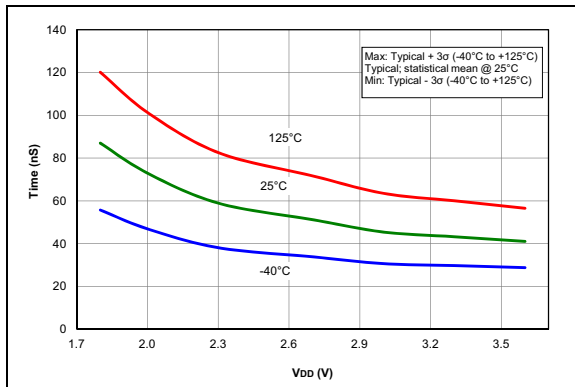

FIGURE 38-56: Comparator Response Time Over Voltage, NP Mode ($CxSP = 1$), Typical Measured Values, PIC16LF18856/76 Only.

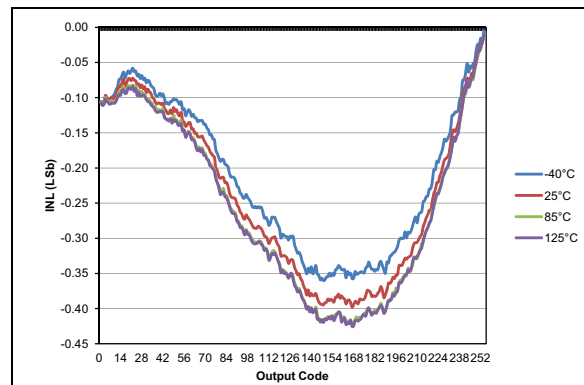

FIGURE 38-59: Typical DAC INL Error, $V_{DD} = 3.0V$, $V_{REF} = \text{External } 3V$.

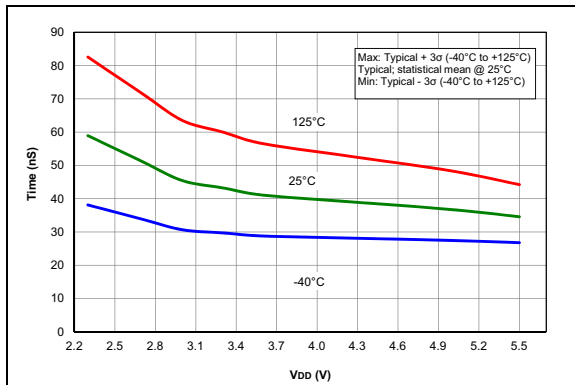

FIGURE 38-57: Comparator Response Time Over Voltage, NP Mode ($CxSP = 1$), Typical Measured Values, PIC16F18856/76 Only.

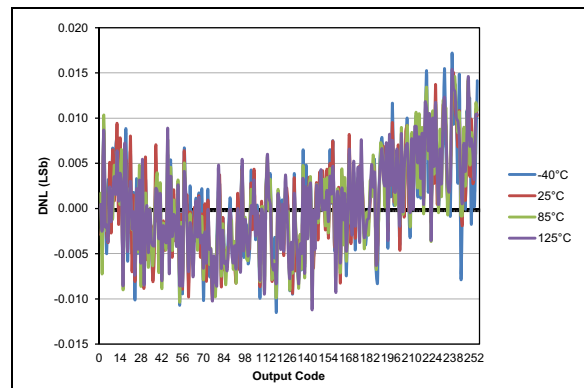

FIGURE 38-60: Typical DAC DNL Error, $V_{DD} = 5.0V$, $V_{REF} = \text{External } 5V$, PIC16F18856/76 Only.

PIC16(L)F18856/76

Note: Unless otherwise noted, $V_{IN} = 5V$, $F_{OSC} = 300\text{ kHz}$, $C_{IN} = 0.1\ \mu\text{F}$, $T_A = 25^\circ\text{C}$.

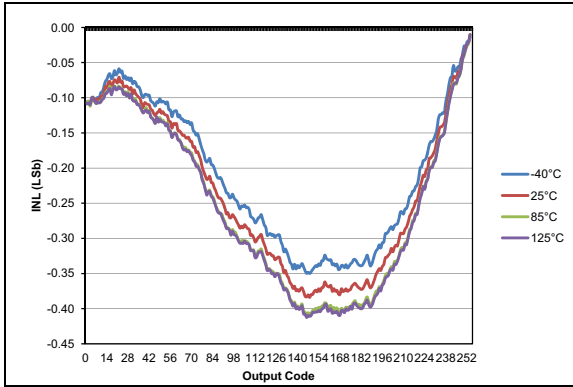

FIGURE 38-61: Typical DAC INL Error, $V_{DD} = 5.0V$, $V_{REF} = \text{External } 5V$, PIC16F18856/76 Only.

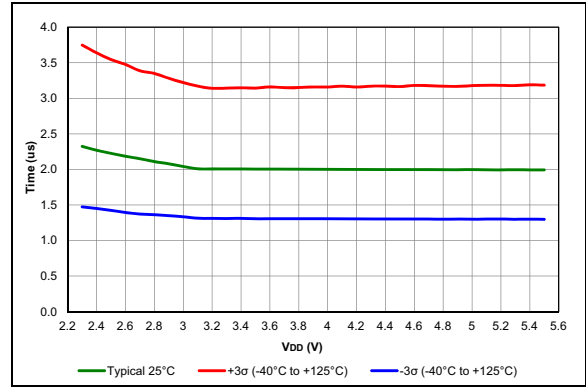

FIGURE 38-64: ADC RC Oscillator Period, PIC16F18856/76 Only.

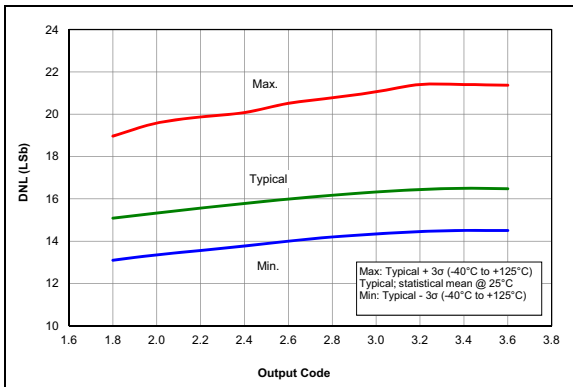

FIGURE 38-62: DAC INL Error, $V_{DD} = 3.0V$, PIC16LF18856/76 Only.

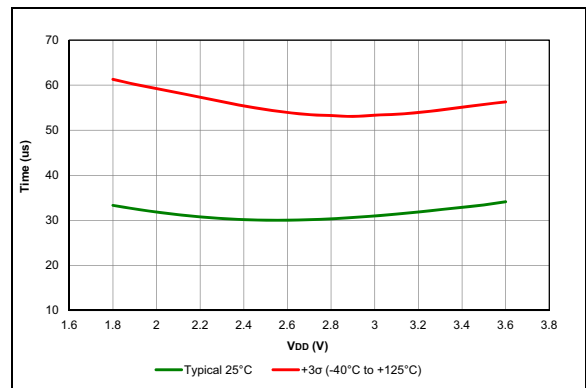

FIGURE 38-65: Bandgap Ready Time, PIC16LF18856/76 Only.

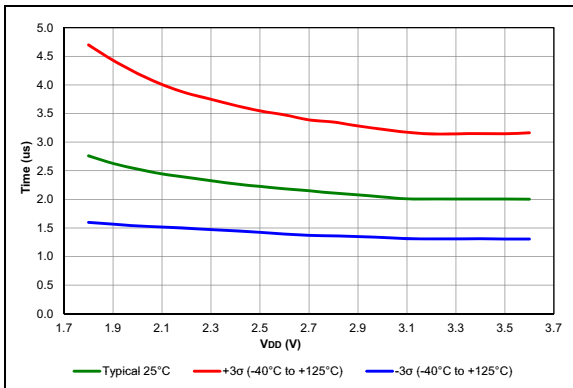

FIGURE 38-63: ADC RC Oscillator Period, PIC16LF18856/76 Only.

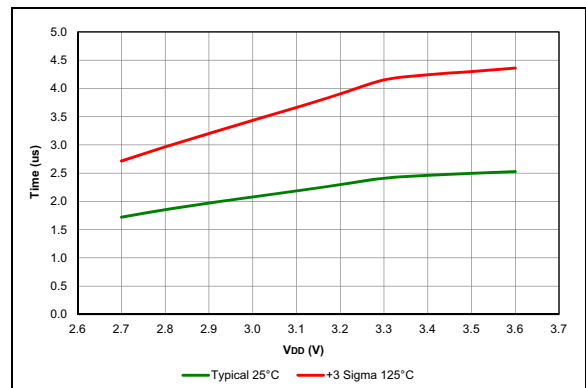

FIGURE 38-66: BOR Response Time, PIC16LF18856/76 Only.

PIC16(L)F18856/76

Note: Unless otherwise noted, $V_{IN} = 5V$, $F_{OSC} = 300\text{ kHz}$, $C_{IN} = 0.1\ \mu F$, $T_A = 25^\circ C$.

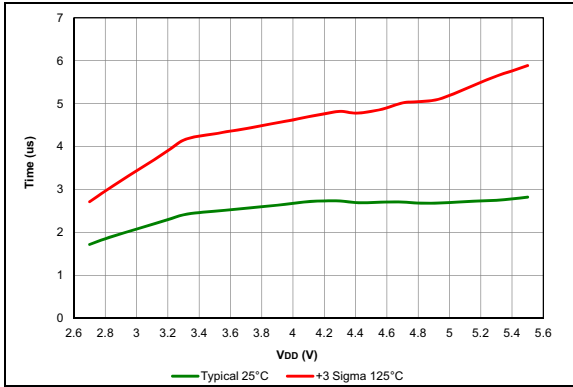

FIGURE 38-67: BOR Response Time, PIC16F18856/76 Only.

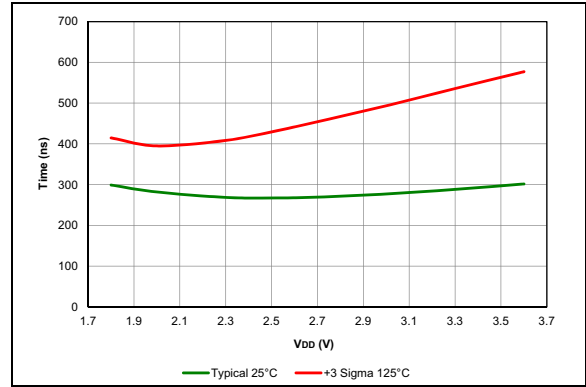

FIGURE 38-70: Comparator Response Time, Rising Edge, PIC16LF18856/76 Only.

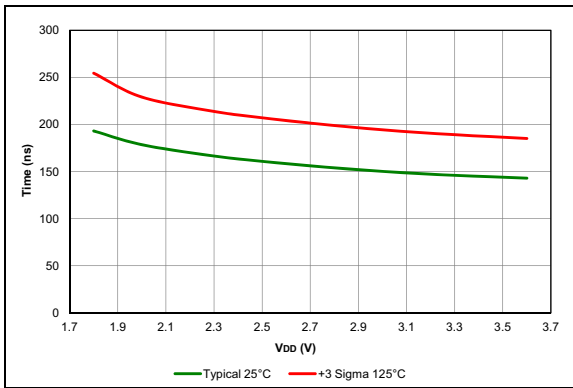

FIGURE 38-68: Comparator Response Time, Falling Edge, PIC16LF18856/76 Only.

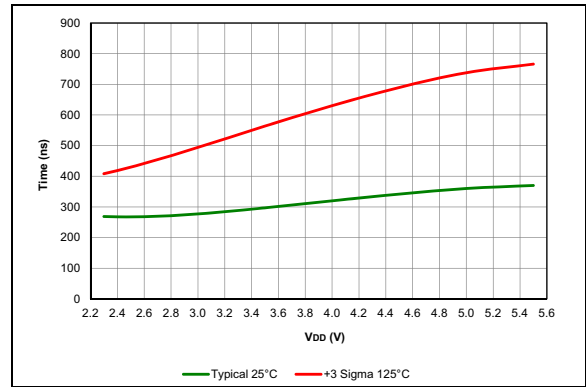

FIGURE 38-71: Comparator Response Time, Rising Edge, PIC16F18856/76 Only.

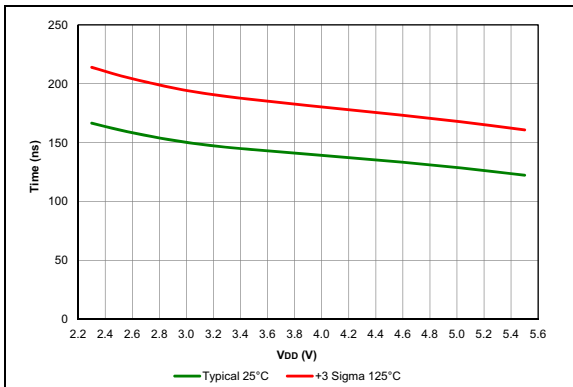

FIGURE 38-69: Comparator Response Time, Falling Edge, PIC16F18856/76 Only.

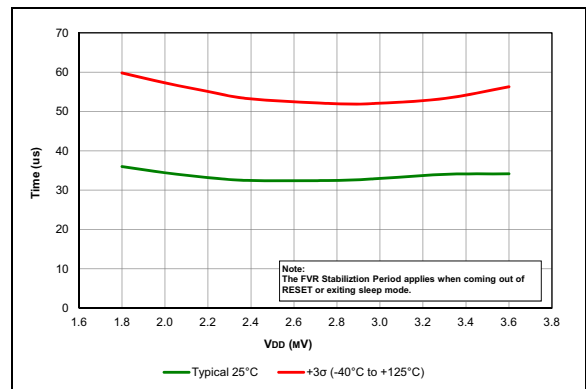

FIGURE 38-72: FVR Stabilization Period, PIC16LF18856/76 Only.

PIC16(L)F18856/76

Note: Unless otherwise noted, $V_{IN} = 5V$, $F_{OSC} = 300\text{ kHz}$, $C_{IN} = 0.1\ \mu\text{F}$, $T_A = 25^\circ\text{C}$.

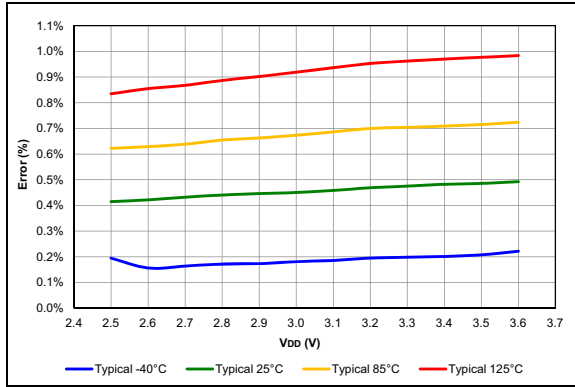

FIGURE 38-73: Typical FVR Voltage 1x, PIC16LF18856/76 Only.

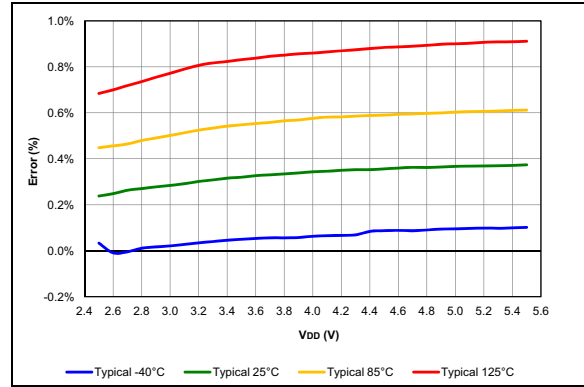

FIGURE 38-76: FVR Voltage Error 2x, PIC16F18856/76 Only.

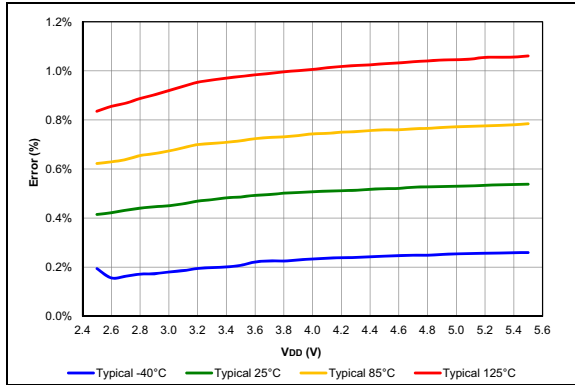

FIGURE 38-74: FVR Voltage Error 1x, PIC16F18856/76 Only.

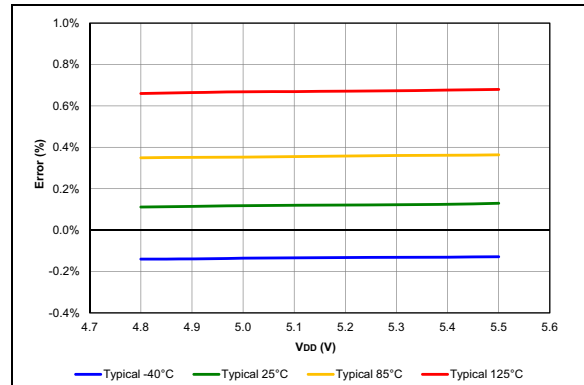

FIGURE 38-77: FVR Voltage Error 4x, PIC16F18856/76 Only.

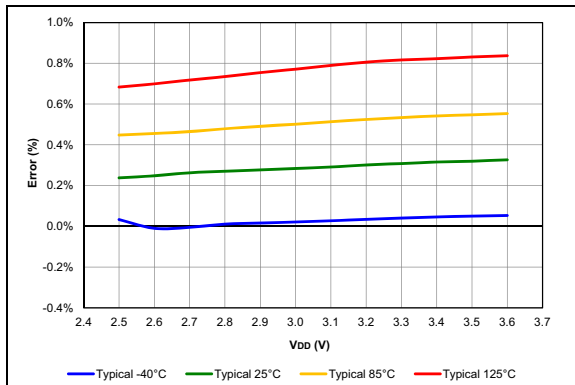

FIGURE 38-75: FVR Voltage Error 2x, PIC16LF18856/76 Only.

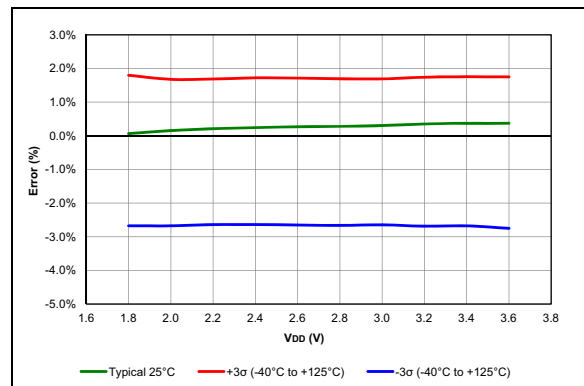

FIGURE 38-78: HFINTOSC Typical Frequency Error, PIC16LF18856/76 Only.

PIC16(L)F18856/76

Note: Unless otherwise noted, $V_{IN} = 5V$, $F_{OSC} = 300\text{ kHz}$, $C_{IN} = 0.1\ \mu\text{F}$, $T_A = 25^\circ\text{C}$.

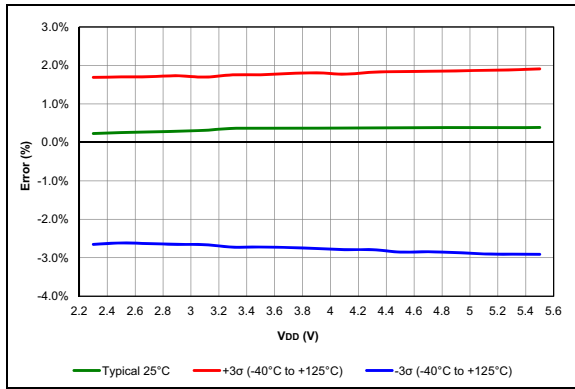

FIGURE 38-79: HFINTOSC Typical Frequency Error, PIC16F18856/76 Only.

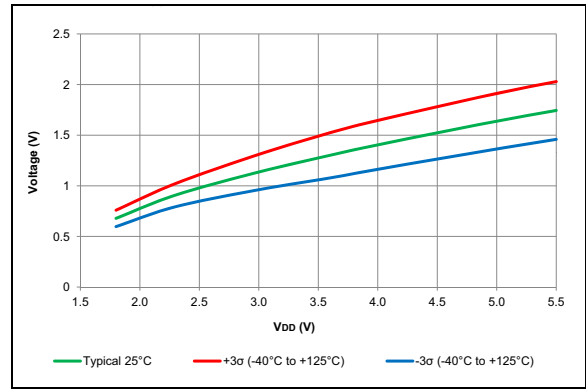

FIGURE 38-82: Schmitt Trigger Low Values.

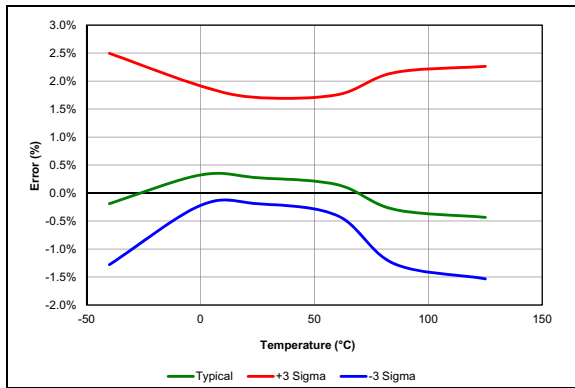

FIGURE 38-80: HFINTOSC Frequency Error, $V_{DD} = 3.0V$.

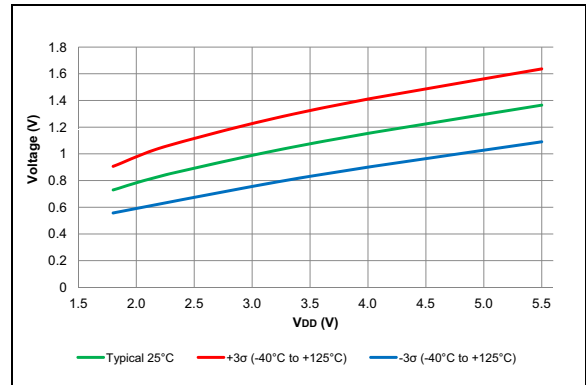

FIGURE 38-83: Input Level, TTL.

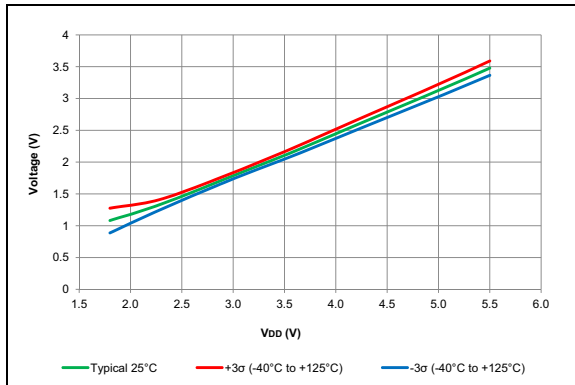

FIGURE 38-81: Schmitt Trigger High Values.

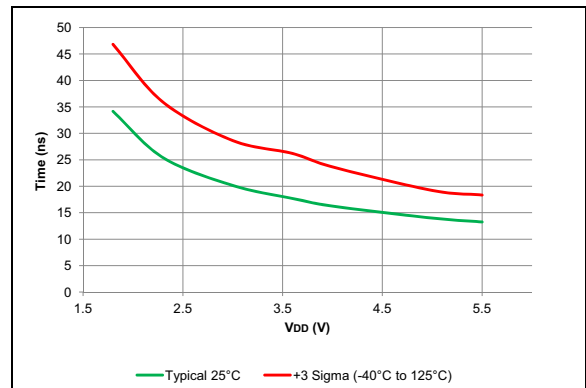

FIGURE 38-84: Rise Time, Slew Rate Control Enabled.

PIC16(L)F18856/76

Note: Unless otherwise noted, $V_{IN} = 5V$, $F_{OSC} = 300\text{ kHz}$, $C_{IN} = 0.1\ \mu\text{F}$, $T_A = 25^\circ\text{C}$.

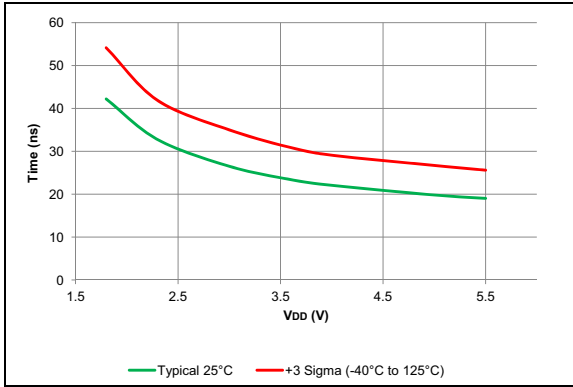

FIGURE 38-85: Fall Time, Slew Rate Control Enabled.

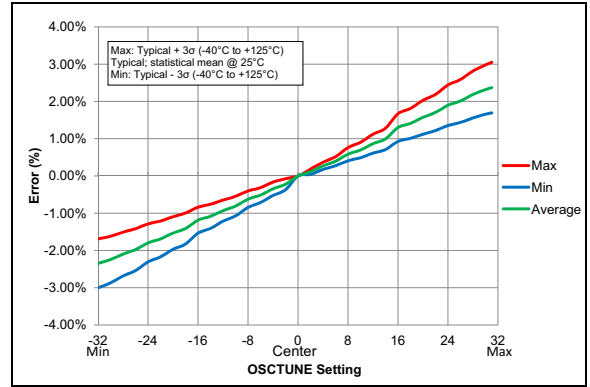

FIGURE 38-88: OSCTUNE Center Frequency, PIC16LF18856/76 Only.

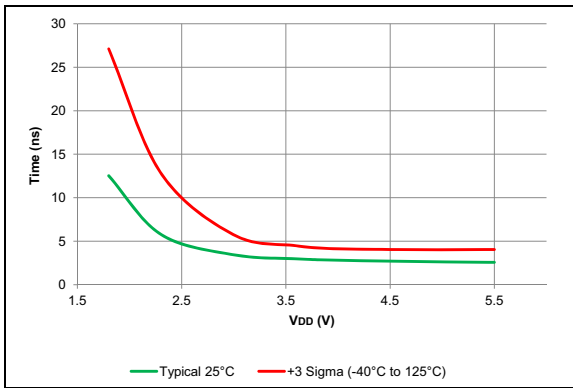

FIGURE 38-86: Rise Time, Slew Rate Control Disabled.

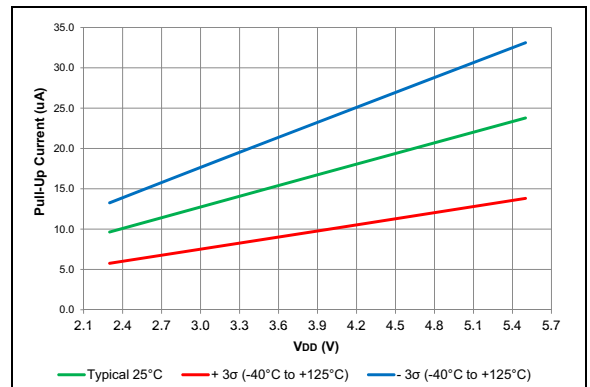

FIGURE 38-89: Weak Pull-up Current, PIC16F18856/76 Only.

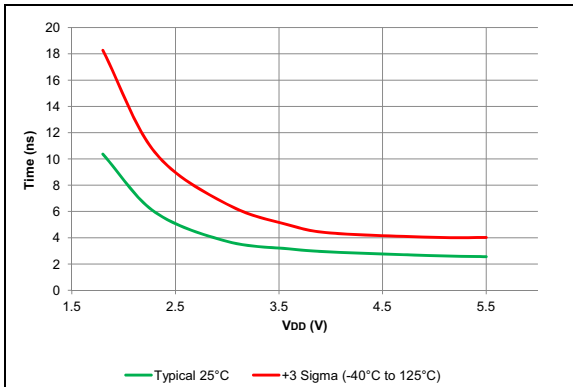

FIGURE 38-87: Fall Time, Slew Rate Control Disabled.

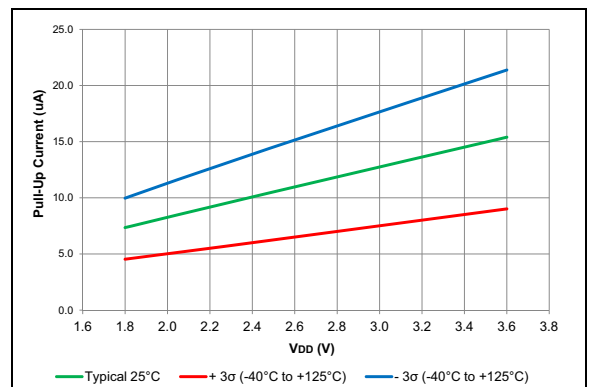

FIGURE 38-90: Weak Pull-up Current, PIC16LF18856/76 Only.

39.0 DEVELOPMENT SUPPORT

The PIC[®] microcontrollers (MCU) and dsPIC[®] digital signal controllers (DSC) are supported with a full range of software and hardware development tools:

- Integrated Development Environment
 - MPLAB[®] X IDE Software
- Compilers/Assemblers/Linkers
 - MPLAB XC Compiler
 - MPASM[™] Assembler
 - MPLINK[™] Object Linker/
MPLIB[™] Object Librarian
 - MPLAB Assembler/Linker/Librarian for
Various Device Families
- Simulators
 - MPLAB X SIM Software Simulator
- Emulators
 - MPLAB REAL ICE[™] In-Circuit Emulator
- In-Circuit Debuggers/Programmers
 - MPLAB ICD 3
 - PICKit[™] 3
- Device Programmers
 - MPLAB PM3 Device Programmer
- Low-Cost Demonstration/Development Boards,
Evaluation Kits and Starter Kits
- Third-party development tools

39.1 MPLAB X Integrated Development Environment Software

The MPLAB X IDE is a single, unified graphical user interface for Microchip and third-party software, and hardware development tool that runs on Windows[®], Linux and Mac OS[®] X. Based on the NetBeans IDE, MPLAB X IDE is an entirely new IDE with a host of free software components and plug-ins for high-performance application development and debugging. Moving between tools and upgrading from software simulators to hardware debugging and programming tools is simple with the seamless user interface.

With complete project management, visual call graphs, a configurable watch window and a feature-rich editor that includes code completion and context menus, MPLAB X IDE is flexible and friendly enough for new users. With the ability to support multiple tools on multiple projects with simultaneous debugging, MPLAB X IDE is also suitable for the needs of experienced users.

Feature-Rich Editor:

- Color syntax highlighting
- Smart code completion makes suggestions and provides hints as you type
- Automatic code formatting based on user-defined rules
- Live parsing

User-Friendly, Customizable Interface:

- Fully customizable interface: toolbars, toolbar buttons, windows, window placement, etc.
- Call graph window

Project-Based Workspaces:

- Multiple projects
- Multiple tools
- Multiple configurations
- Simultaneous debugging sessions

File History and Bug Tracking:

- Local file history feature
- Built-in support for Bugzilla issue tracker

39.2 MPLAB XC Compilers

The MPLAB XC Compilers are complete ANSI C compilers for all of Microchip's 8, 16, and 32-bit MCU and DSC devices. These compilers provide powerful integration capabilities, superior code optimization and ease of use. MPLAB XC Compilers run on Windows, Linux or MAC OS X.

For easy source level debugging, the compilers provide debug information that is optimized to the MPLAB X IDE.

The free MPLAB XC Compiler editions support all devices and commands, with no time or memory restrictions, and offer sufficient code optimization for most applications.

MPLAB XC Compilers include an assembler, linker and utilities. The assembler generates relocatable object files that can then be archived or linked with other relocatable object files and archives to create an executable file. MPLAB XC Compiler uses the assembler to produce its object file. Notable features of the assembler include:

- Support for the entire device instruction set
- Support for fixed-point and floating-point data
- Command-line interface
- Rich directive set
- Flexible macro language
- MPLAB X IDE compatibility

39.3 MPASM Assembler

The MPASM Assembler is a full-featured, universal macro assembler for PIC10/12/16/18 MCUs.

The MPASM Assembler generates relocatable object files for the MPLINK Object Linker, Intel® standard HEX files, MAP files to detail memory usage and symbol reference, absolute LST files that contain source lines and generated machine code, and COFF files for debugging.

The MPASM Assembler features include:

- Integration into MPLAB X IDE projects
- User-defined macros to streamline assembly code
- Conditional assembly for multipurpose source files
- Directives that allow complete control over the assembly process

39.4 MPLINK Object Linker/ MPLIB Object Librarian

The MPLINK Object Linker combines relocatable objects created by the MPASM Assembler. It can link relocatable objects from precompiled libraries, using directives from a linker script.

The MPLIB Object Librarian manages the creation and modification of library files of precompiled code. When a routine from a library is called from a source file, only the modules that contain that routine will be linked in with the application. This allows large libraries to be used efficiently in many different applications.

The object linker/librarian features include:

- Efficient linking of single libraries instead of many smaller files
- Enhanced code maintainability by grouping related modules together
- Flexible creation of libraries with easy module listing, replacement, deletion and extraction

39.5 MPLAB Assembler, Linker and Librarian for Various Device Families

MPLAB Assembler produces relocatable machine code from symbolic assembly language for PIC24, PIC32 and dsPIC DSC devices. MPLAB XC Compiler uses the assembler to produce its object file. The assembler generates relocatable object files that can then be archived or linked with other relocatable object files and archives to create an executable file. Notable features of the assembler include:

- Support for the entire device instruction set
- Support for fixed-point and floating-point data
- Command-line interface
- Rich directive set
- Flexible macro language
- MPLAB X IDE compatibility

39.6 MPLAB X SIM Software Simulator

The MPLAB X SIM Software Simulator allows code development in a PC-hosted environment by simulating the PIC MCUs and dsPIC DSCs on an instruction level. On any given instruction, the data areas can be examined or modified and stimuli can be applied from a comprehensive stimulus controller. Registers can be logged to files for further run-time analysis. The trace buffer and logic analyzer display extend the power of the simulator to record and track program execution, actions on I/O, most peripherals and internal registers.

The MPLAB X SIM Software Simulator fully supports symbolic debugging using the MPLAB XC Compilers, and the MPASM and MPLAB Assemblers. The software simulator offers the flexibility to develop and debug code outside of the hardware laboratory environment, making it an excellent, economical software development tool.

39.7 MPLAB REAL ICE In-Circuit Emulator System

The MPLAB REAL ICE In-Circuit Emulator System is Microchip's next generation high-speed emulator for Microchip Flash DSC and MCU devices. It debugs and programs all 8, 16 and 32-bit MCU, and DSC devices with the easy-to-use, powerful graphical user interface of the MPLAB X IDE.

The emulator is connected to the design engineer's PC using a high-speed USB 2.0 interface and is connected to the target with either a connector compatible with in-circuit debugger systems (RJ-11) or with the new high-speed, noise tolerant, Low-Voltage Differential Signal (LVDS) interconnection (CAT5).

The emulator is field upgradeable through future firmware downloads in MPLAB X IDE. MPLAB REAL ICE offers significant advantages over competitive emulators including full-speed emulation, run-time variable watches, trace analysis, complex breakpoints, logic probes, a ruggedized probe interface and long (up to three meters) interconnection cables.

39.8 MPLAB ICD 3 In-Circuit Debugger System

The MPLAB ICD 3 In-Circuit Debugger System is Microchip's most cost-effective, high-speed hardware debugger/programmer for Microchip Flash DSC and MCU devices. It debugs and programs PIC Flash microcontrollers and dsPIC DSCs with the powerful, yet easy-to-use graphical user interface of the MPLAB IDE.

The MPLAB ICD 3 In-Circuit Debugger probe is connected to the design engineer's PC using a high-speed USB 2.0 interface and is connected to the target with a connector compatible with the MPLAB ICD 2 or MPLAB REAL ICE systems (RJ-11). MPLAB ICD 3 supports all MPLAB ICD 2 headers.

39.9 PICkit 3 In-Circuit Debugger/Programmer

The MPLAB PICkit 3 allows debugging and programming of PIC and dsPIC Flash microcontrollers at a most affordable price point using the powerful graphical user interface of the MPLAB IDE. The MPLAB PICkit 3 is connected to the design engineer's PC using a full-speed USB interface and can be connected to the target via a Microchip debug (RJ-11) connector (compatible with MPLAB ICD 3 and MPLAB REAL ICE). The connector uses two device I/O pins and the Reset line to implement in-circuit debugging and In-Circuit Serial Programming™ (ICSP™).

39.10 MPLAB PM3 Device Programmer

The MPLAB PM3 Device Programmer is a universal, CE compliant device programmer with programmable voltage verification at VDDMIN and VDDMAX for maximum reliability. It features a large LCD display (128 x 64) for menus and error messages, and a modular, detachable socket assembly to support various package types. The ICSP cable assembly is included as a standard item. In Stand-Alone mode, the MPLAB PM3 Device Programmer can read, verify and program PIC devices without a PC connection. It can also set code protection in this mode. The MPLAB PM3 connects to the host PC via an RS-232 or USB cable. The MPLAB PM3 has high-speed communications and optimized algorithms for quick programming of large memory devices, and incorporates an MMC card for file storage and data applications.

39.11 Demonstration/Development Boards, Evaluation Kits, and Starter Kits

A wide variety of demonstration, development and evaluation boards for various PIC MCUs and dsPIC DSCs allows quick application development on fully functional systems. Most boards include prototyping areas for adding custom circuitry and provide application firmware and source code for examination and modification.

The boards support a variety of features, including LEDs, temperature sensors, switches, speakers, RS-232 interfaces, LCD displays, potentiometers and additional EEPROM memory.

The demonstration and development boards can be used in teaching environments, for prototyping custom circuits and for learning about various microcontroller applications.

In addition to the PICDEM™ and dsPICDEM™ demonstration/development board series of circuits, Microchip has a line of evaluation kits and demonstration software for analog filter design, KEELOQ® security ICs, CAN, IrDA®, PowerSmart battery management, SEEVAL® evaluation system, Sigma-Delta ADC, flow rate sensing, plus many more.

Also available are starter kits that contain everything needed to experience the specified device. This usually includes a single application and debug capability, all on one board.

Check the Microchip web page (www.microchip.com) for the complete list of demonstration, development and evaluation kits.

39.12 Third-Party Development Tools

Microchip also offers a great collection of tools from third-party vendors. These tools are carefully selected to offer good value and unique functionality.

- Device Programmers and Gang Programmers from companies, such as SoftLog and CCS
- Software Tools from companies, such as Gimpel and Trace Systems
- Protocol Analyzers from companies, such as Saleae and Total Phase
- Demonstration Boards from companies, such as MikroElektronika, Digilent® and Olimex
- Embedded Ethernet Solutions from companies, such as EZ Web Lynx, WIZnet and IPLogika®

PIC16(L)F18856/76

40.0 PACKAGING INFORMATION

40.1 Package Marking Information

28-Lead SPDIP (.300")

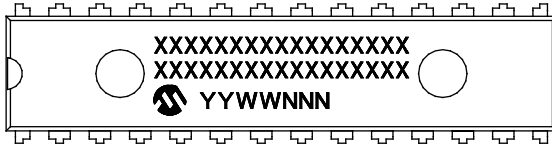

Example

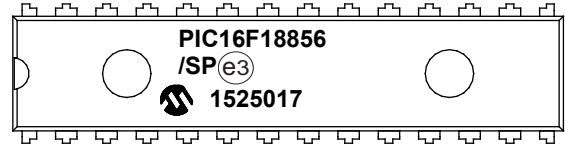

28-Lead SOIC (7.50 mm)

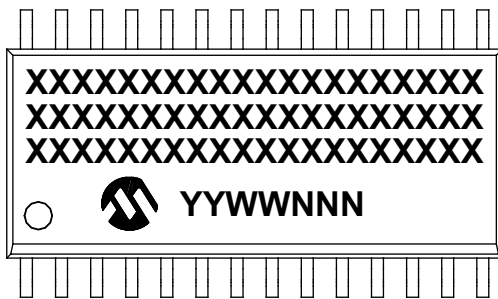

Example

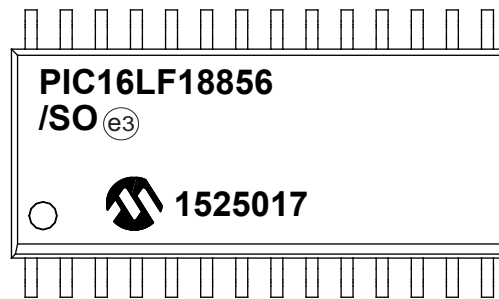

28-Lead SSOP (5.30 mm)

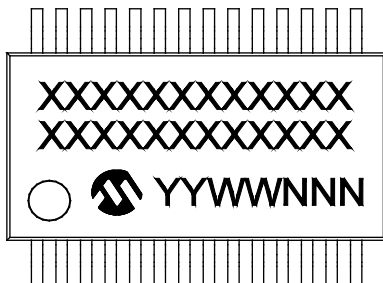

Example

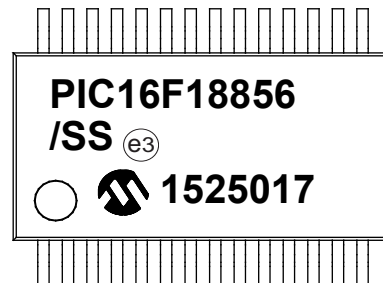

Legend:	XX...X	Customer-specific information
	Y	Year code (last digit of calendar year)
	YY	Year code (last 2 digits of calendar year)
	WW	Week code (week of January 1 is week '01')
	NNN	Alphanumeric traceability code
	(e3)	Pb-free JEDEC® designator for Matte Tin (Sn)
	*	This package is Pb-free. The Pb-free JEDEC designator (e3) can be found on the outer packaging for this package.
Note:	In the event the full Microchip part number cannot be marked on one line, it will be carried over to the next line, thus limiting the number of available characters for customer-specific information.	

PIC16(L)F18856/76

40.1 Package Marking Information (Continued)

28-Lead QFN (6x6 mm)

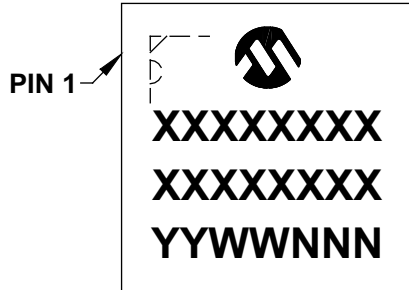

Example

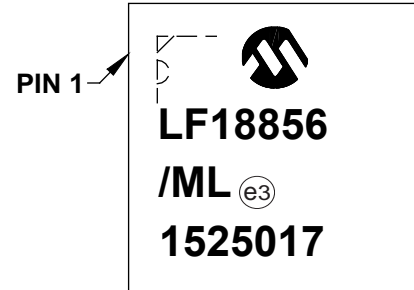

28-Lead UQFN (4x4x0.5 mm)

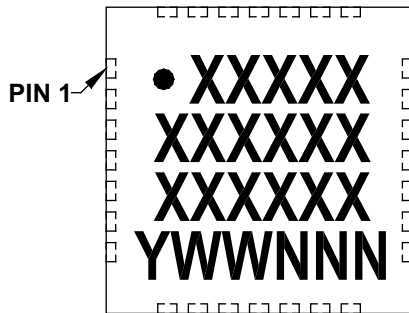

Example

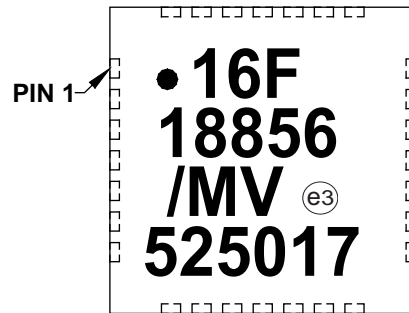

Legend:	XX...X	Customer-specific information
	Y	Year code (last digit of calendar year)
	YY	Year code (last 2 digits of calendar year)
	WW	Week code (week of January 1 is week '01')
	NNN	Alphanumeric traceability code
		Pb-free JEDEC® designator for Matte Tin (Sn)
	*	This package is Pb-free. The Pb-free JEDEC designator (e3) can be found on the outer packaging for this package.
Note:	In the event the full Microchip part number cannot be marked on one line, it will be carried over to the next line, thus limiting the number of available characters for customer-specific information.	

PIC16(L)F18856/76

40.1 Package Marking Information (Continued)

40-Lead PDIP (600 mil)

Example

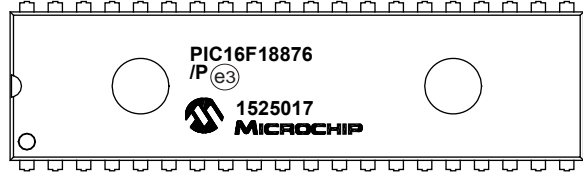
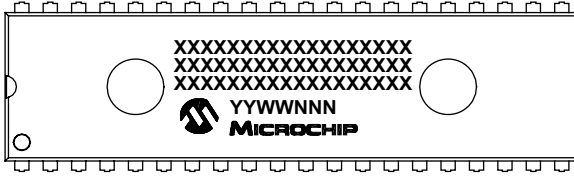

40-Lead UQFN (5x5x0.5 mm)

Example

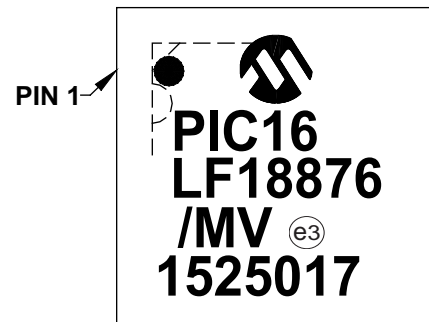
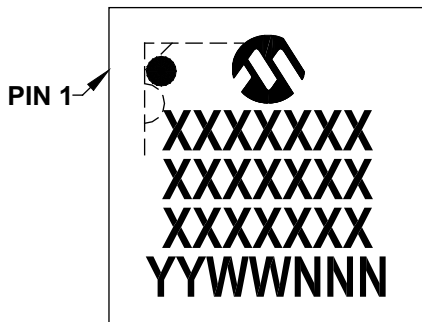

Legend:	XX...X	Customer-specific information
	Y	Year code (last digit of calendar year)
	YY	Year code (last 2 digits of calendar year)
	WW	Week code (week of January 1 is week '01')
	NNN	Alphanumeric traceability code
	*	Pb-free JEDEC® designator for Matte Tin (Sn)
		This package is Pb-free. The Pb-free JEDEC designator (e3) can be found on the outer packaging for this package.
Note:	In the event the full Microchip part number cannot be marked on one line, it will be carried over to the next line, thus limiting the number of available characters for customer-specific information.	

PIC16(L)F18856/76

40.1 Package Marking Information (Continued)

44-Lead TQFP (10x10x1 mm)

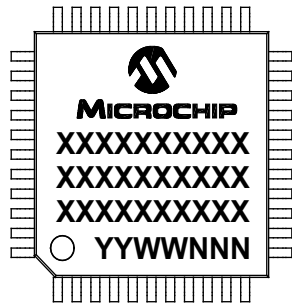

Example

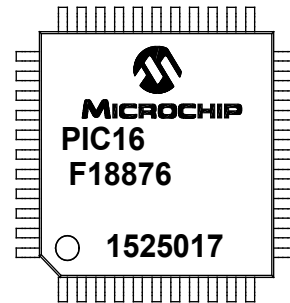

44-Lead QFN (8x8x0.9 mm)

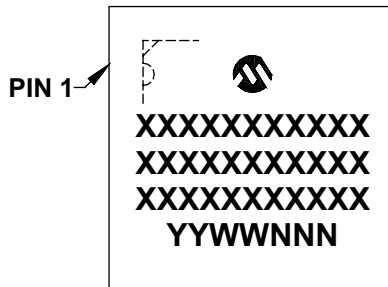

Example

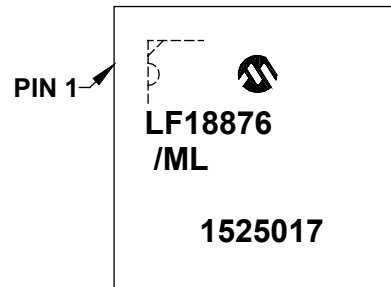

Legend:	XX...X	Customer-specific information
	Y	Year code (last digit of calendar year)
	YY	Year code (last 2 digits of calendar year)
	WW	Week code (week of January 1 is week '01')
	NNN	Alphanumeric traceability code
	*	Pb-free JEDEC® designator for Matte Tin (Sn) This package is Pb-free. The Pb-free JEDEC designator (e3) can be found on the outer packaging for this package.
Note:	In the event the full Microchip part number cannot be marked on one line, it will be carried over to the next line, thus limiting the number of available characters for customer-specific information.	

PIC16(L)F18856/76

40.2 Package Details

The following sections give the technical details of the packages.

28-Lead Skinny Plastic Dual In-Line (SP) – 300 mil Body [SPDIP]

Note: For the most current package drawings, please see the Microchip Packaging Specification located at <http://www.microchip.com/packaging>

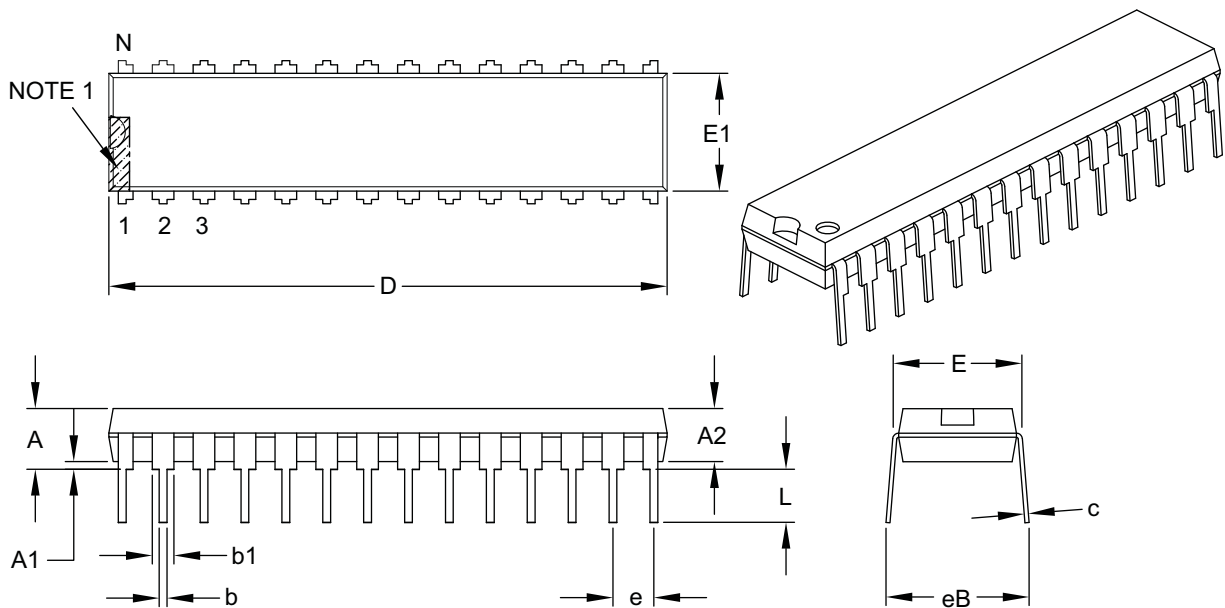

Dimension Limits	Units	INCHES		
		MIN	NOM	MAX
Number of Pins	N	28		
Pitch	e	.100 BSC		
Top to Seating Plane	A	–	–	.200
Molded Package Thickness	A2	.120	.135	.150
Base to Seating Plane	A1	.015	–	–
Shoulder to Shoulder Width	E	.290	.310	.335
Molded Package Width	E1	.240	.285	.295
Overall Length	D	1.345	1.365	1.400
Tip to Seating Plane	L	.110	.130	.150
Lead Thickness	c	.008	.010	.015
Upper Lead Width	b1	.040	.050	.070
Lower Lead Width	b	.014	.018	.022
Overall Row Spacing §	eB	–	–	.430

Notes:

1. Pin 1 visual index feature may vary, but must be located within the hatched area.
2. § Significant Characteristic.
3. Dimensions D and E1 do not include mold flash or protrusions. Mold flash or protrusions shall not exceed .010" per side.
4. Dimensioning and tolerancing per ASME Y14.5M.

BSC: Basic Dimension. Theoretically exact value shown without tolerances.

Microchip Technology Drawing C04-070B

PIC16(L)F18856/76

28-Lead Plastic Small Outline (SO) - Wide, 7.50 mm Body [SOIC]

Note: For the most current package drawings, please see the Microchip Packaging Specification located at <http://www.microchip.com/packaging>

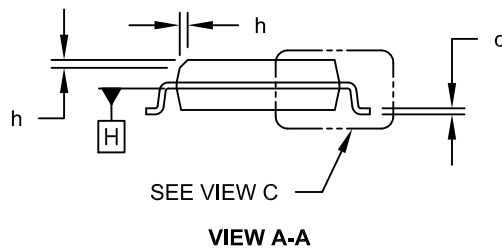
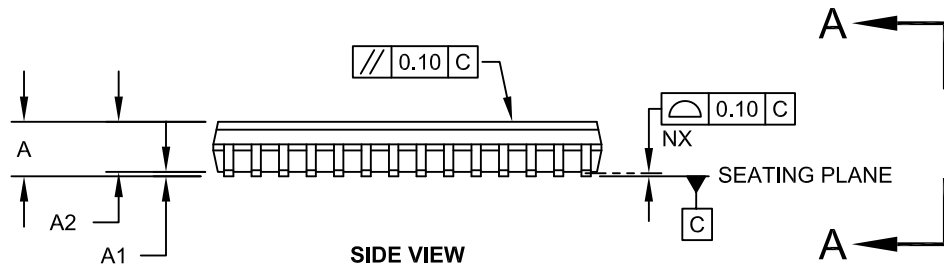
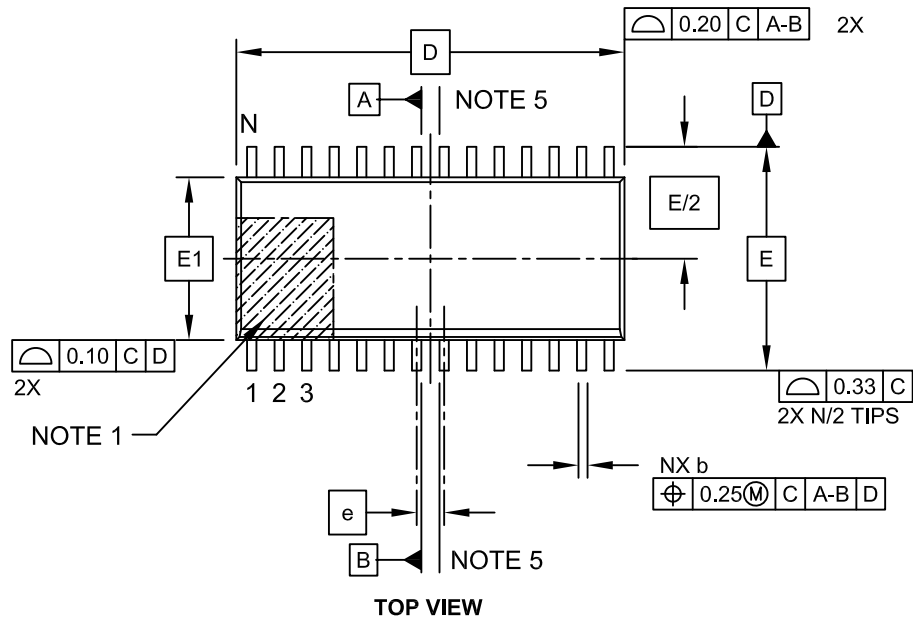

Microchip Technology Drawing C04-052C Sheet 1 of 2

PIC16(L)F18856/76

28-Lead Plastic Small Outline (SO) - Wide, 7.50 mm Body [SOIC]

Note: For the most current package drawings, please see the Microchip Packaging Specification located at <http://www.microchip.com/packaging>

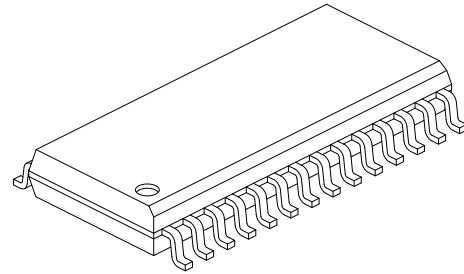
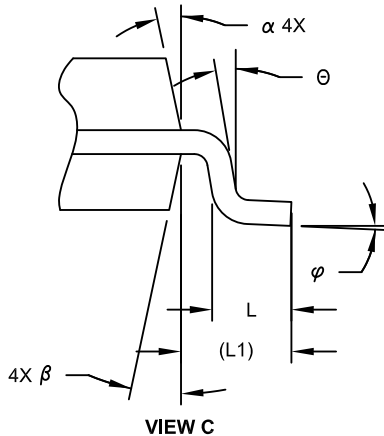

		MILLIMETERS		
Units		MIN	NOM	MAX
Dimension Limits				
Number of Pins	N	28		
Pitch	e	1.27 BSC		
Overall Height	A	-	-	2.65
Molded Package Thickness	A2	2.05	-	-
Standoff §	A1	0.10	-	0.30
Overall Width	E	10.30 BSC		
Molded Package Width	E1	7.50 BSC		
Overall Length	D	17.90 BSC		
Chamfer (Optional)	h	0.25	-	0.75
Foot Length	L	0.40	-	1.27
Footprint	L1	1.40 REF		
Lead Angle	θ	0°	-	-
Foot Angle	φ	0°	-	8°
Lead Thickness	c	0.18	-	0.33
Lead Width	b	0.31	-	0.51
Mold Draft Angle Top	α	5°	-	15°
Mold Draft Angle Bottom	β	5°	-	15°

Notes:

- Pin 1 visual index feature may vary, but must be located within the hatched area.
- § Significant Characteristic
- Dimension D does not include mold flash, protrusions or gate burrs, which shall not exceed 0.15 mm per end. Dimension E1 does not include interlead flash or protrusion, which shall not exceed 0.25 mm per side.
- Dimensioning and tolerancing per ASME Y14.5M
 BSC: Basic Dimension. Theoretically exact value shown without tolerances.
 REF: Reference Dimension, usually without tolerance, for information purposes only.
- Datums A & B to be determined at Datum H.

Microchip Technology Drawing C04-052C Sheet 2 of 2

PIC16(L)F18856/76

28-Lead Plastic Small Outline (SO) - Wide, 7.50 mm Body [SOIC]

Note: For the most current package drawings, please see the Microchip Packaging Specification located at <http://www.microchip.com/packaging>

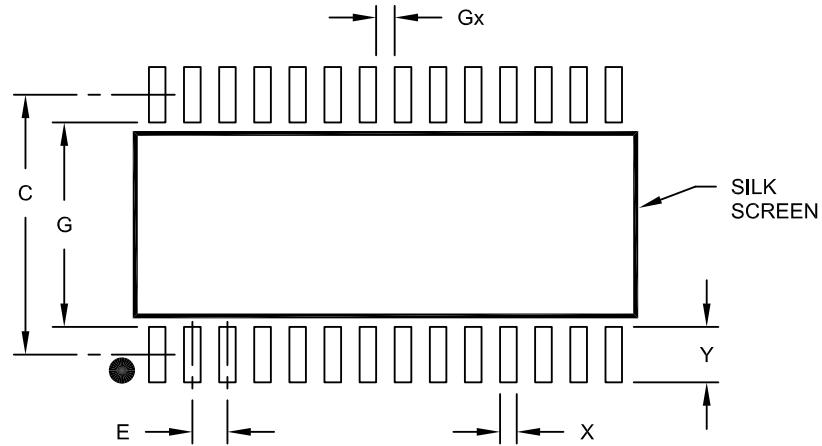

RECOMMENDED LAND PATTERN

Dimension Limits		MILLIMETERS		
		MIN	NOM	MAX
Contact Pitch	E	1.27 BSC		
Contact Pad Spacing	C		9.40	
Contact Pad Width (X28)	X			0.60
Contact Pad Length (X28)	Y			2.00
Distance Between Pads	Gx	0.67		
Distance Between Pads	G	7.40		

Notes:

1. Dimensioning and tolerancing per ASME Y14.5M

BSC: Basic Dimension. Theoretically exact value shown without tolerances.

Microchip Technology Drawing No. C04-2052A

PIC16(L)F18856/76

28-Lead Plastic Shrink Small Outline (SS) – 5.30 mm Body [SSOP]

Note: For the most current package drawings, please see the Microchip Packaging Specification located at <http://www.microchip.com/packaging>

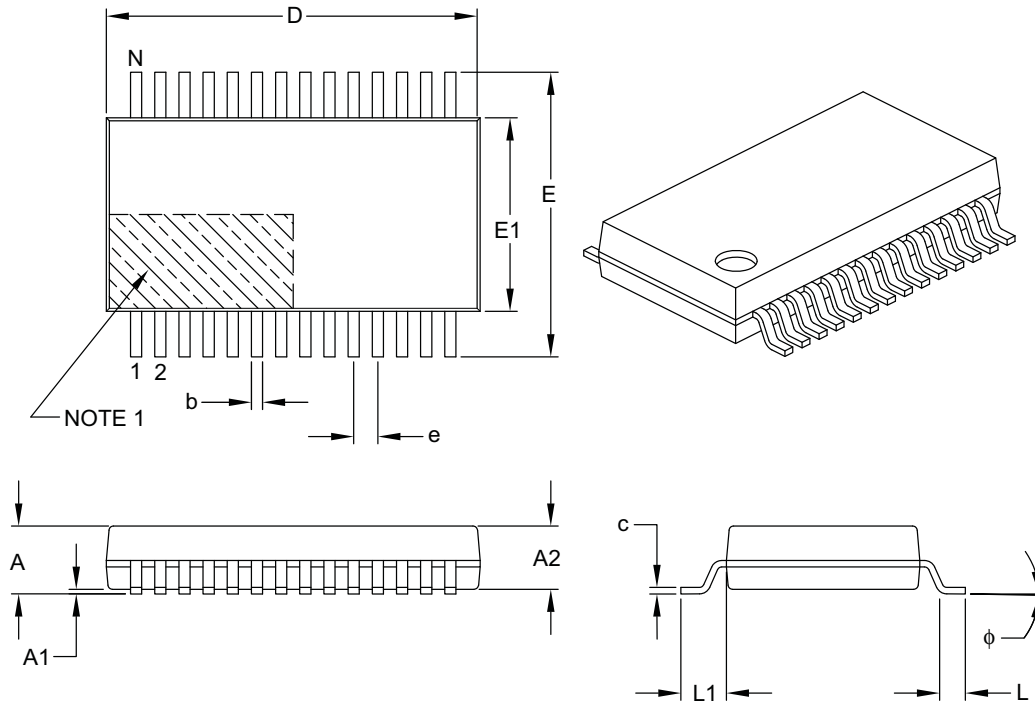

Dimension Limits	Units	MILLIMETERS		
		MIN	NOM	MAX
Number of Pins	N	28		
Pitch	e	0.65 BSC		
Overall Height	A	–	–	2.00
Molded Package Thickness	A2	1.65	1.75	1.85
Standoff	A1	0.05	–	–
Overall Width	E	7.40	7.80	8.20
Molded Package Width	E1	5.00	5.30	5.60
Overall Length	D	9.90	10.20	10.50
Foot Length	L	0.55	0.75	0.95
Footprint	L1	1.25 REF		
Lead Thickness	c	0.09	–	0.25
Foot Angle	φ	0°	4°	8°
Lead Width	b	0.22	–	0.38

Notes:

- Pin 1 visual index feature may vary, but must be located within the hatched area.
- Dimensions D and E1 do not include mold flash or protrusions. Mold flash or protrusions shall not exceed 0.20 mm per side.
- Dimensioning and tolerancing per ASME Y14.5M.

BSC: Basic Dimension. Theoretically exact value shown without tolerances.

REF: Reference Dimension, usually without tolerance, for information purposes only.

Microchip Technology Drawing C04-073B

PIC16(L)F18856/76

28-Lead Plastic Shrink Small Outline (SS) - 5.30 mm Body [SSOP]

Note: For the most current package drawings, please see the Microchip Packaging Specification located at <http://www.microchip.com/packaging>

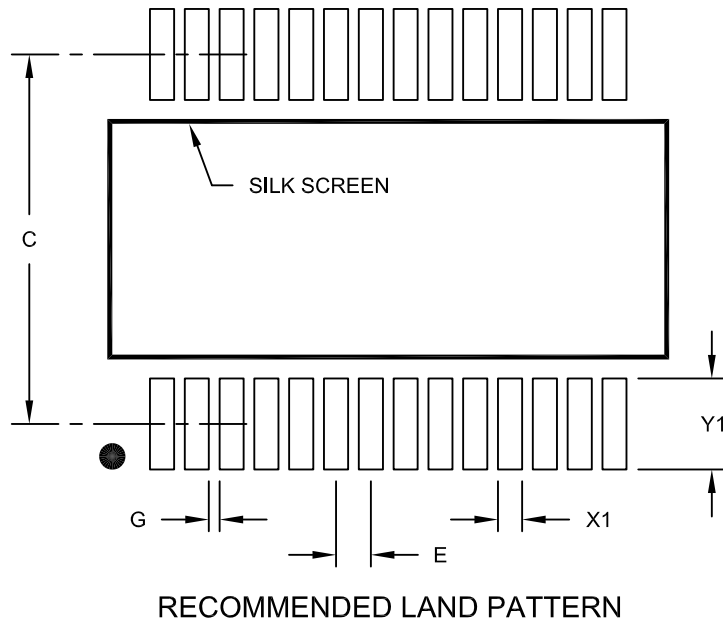

Dimension Limits	Units	MILLIMETERS		
		MIN	NOM	MAX
Contact Pitch	E	0.65 BSC		
Contact Pad Spacing	C		7.20	
Contact Pad Width (X28)	X1			0.45
Contact Pad Length (X28)	Y1			1.75
Distance Between Pads	G	0.20		

Notes:

1. Dimensioning and tolerancing per ASME Y14.5M

BSC: Basic Dimension. Theoretically exact value shown without tolerances.

Microchip Technology Drawing No. C04-2073A

PIC16(L)F18856/76

28-Lead Plastic Quad Flat, No Lead Package (ML) - 6x6 mm Body [QFN] With 0.55 mm Terminal Length

Note: For the most current package drawings, please see the Microchip Packaging Specification located at <http://www.microchip.com/packaging>

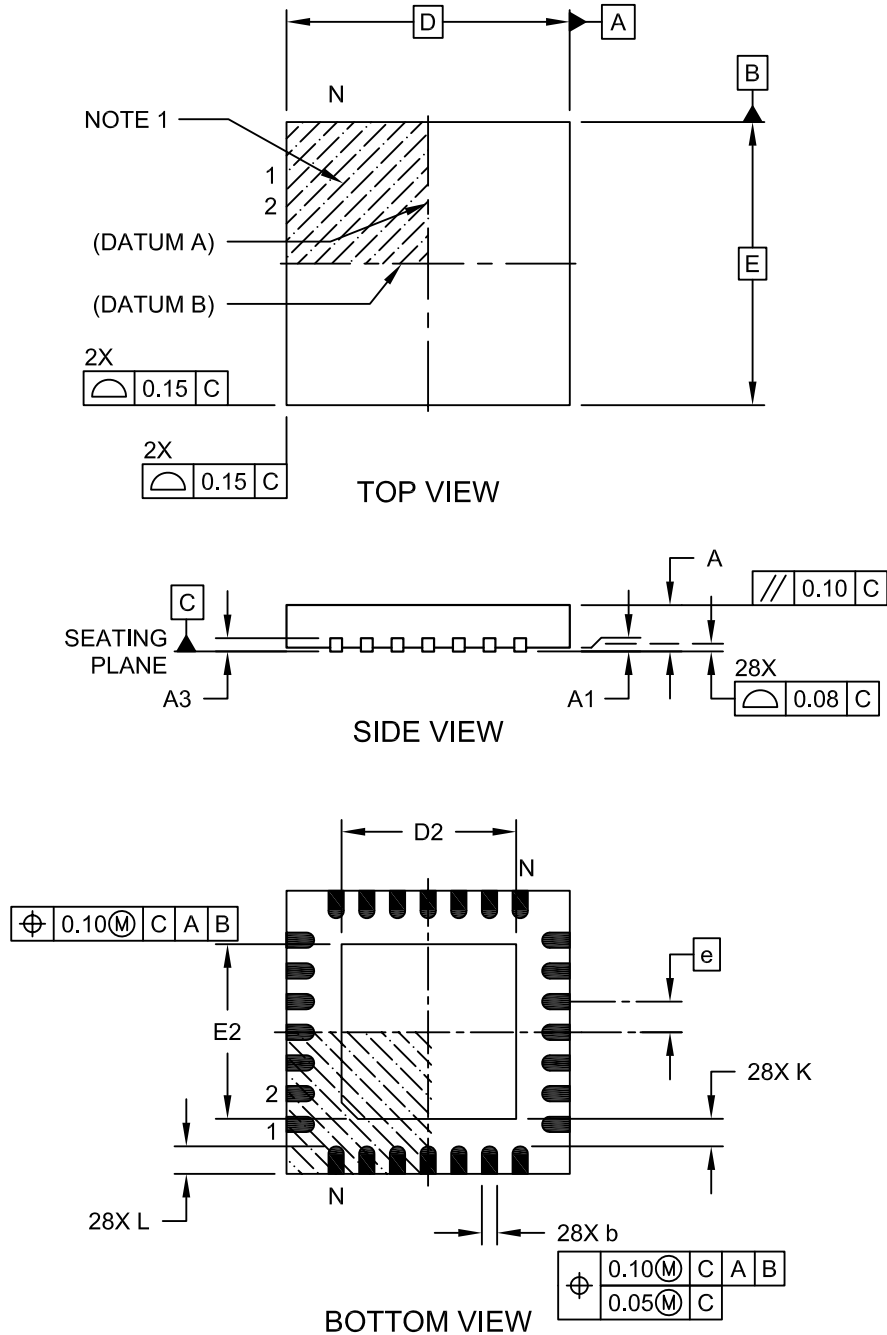

Microchip Technology Drawing C04-105C Sheet 1 of 2

PIC16(L)F18856/76

28-Lead Plastic Quad Flat, No Lead Package (ML) - 6x6 mm Body [QFN] With 0.55 mm Terminal Length

Note: For the most current package drawings, please see the Microchip Packaging Specification located at <http://www.microchip.com/packaging>

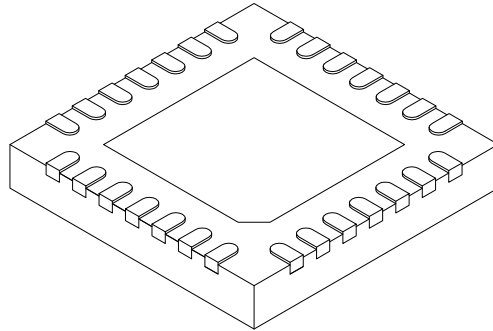

Dimension	Units Limits	MILLIMETERS		
		MIN	NOM	MAX
Number of Pins	N	28		
Pitch	e	0.65 BSC		
Overall Height	A	0.80	0.90	1.00
Standoff	A1	0.00	0.02	0.05
Terminal Thickness	A3	0.20 REF		
Overall Width	E	6.00 BSC		
Exposed Pad Width	E2	3.65	3.70	4.20
Overall Length	D	6.00 BSC		
Exposed Pad Length	D2	3.65	3.70	4.20
Terminal Width	b	0.23	0.30	0.35
Terminal Length	L	0.50	0.55	0.70
Terminal-to-Exposed Pad	K	0.20	-	-

Notes:

1. Pin 1 visual index feature may vary, but must be located within the hatched area.
2. Package is saw singulated
3. Dimensioning and tolerancing per ASME Y14.5M.
BSC: Basic Dimension. Theoretically exact value shown without tolerances.
REF: Reference Dimension, usually without tolerance, for information purposes only.

Microchip Technology Drawing C04-105C Sheet 2 of 2

PIC16(L)F18856/76

28-Lead Plastic Quad Flat, No Lead Package (ML) – 6x6 mm Body [QFN] with 0.55 mm Contact Length

Note: For the most current package drawings, please see the Microchip Packaging Specification located at <http://www.microchip.com/packaging>

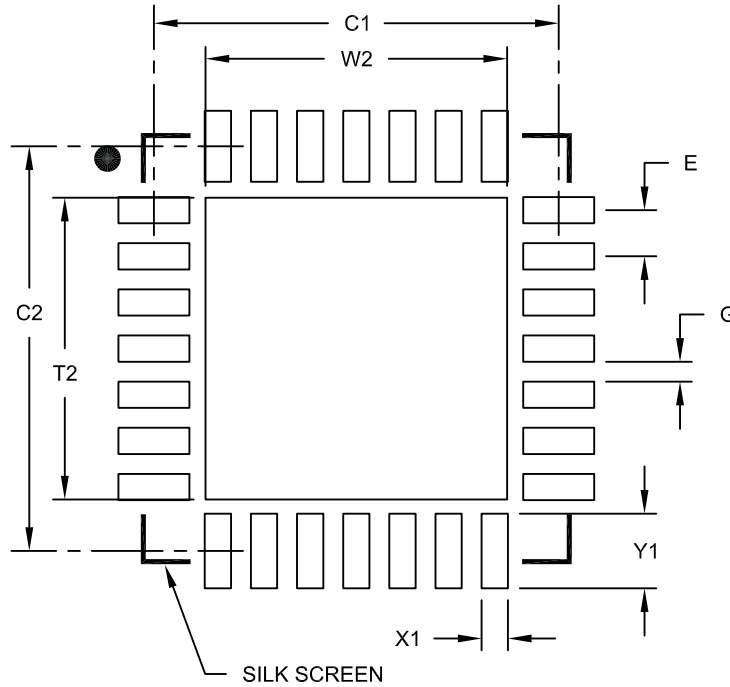

RECOMMENDED LAND PATTERN

Dimension Limits	Units	MILLIMETERS		
		MIN	NOM	MAX
Contact Pitch	E		0.65 BSC	
Optional Center Pad Width	W2			4.25
Optional Center Pad Length	T2			4.25
Contact Pad Spacing	C1		5.70	
Contact Pad Spacing	C2		5.70	
Contact Pad Width (X28)	X1			0.37
Contact Pad Length (X28)	Y1			1.00
Distance Between Pads	G	0.20		

Notes:

1. Dimensioning and tolerancing per ASME Y14.5M

BSC: Basic Dimension. Theoretically exact value shown without tolerances.

Microchip Technology Drawing No. C04-2105A

PIC16(L)F18856/76

28-Lead Plastic Ultra Thin Quad Flat, No Lead Package (MV) – 4x4x0.5 mm Body [UQFN]

Note: For the most current package drawings, please see the Microchip Packaging Specification located at <http://www.microchip.com/packaging>

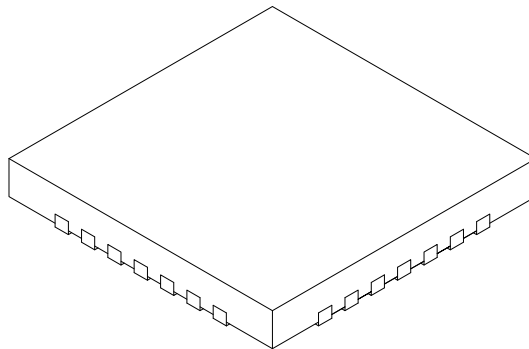

Units		MILLIMETERS		
Dimension Limits		MIN	NOM	MAX
Number of Pins	N	28		
Pitch	e	0.40 BSC		
Overall Height	A	0.45	0.50	0.55
Standoff	A1	0.00	0.02	0.05
Contact Thickness	A3	0.127 REF		
Overall Width	E	4.00 BSC		
Exposed Pad Width	E2	2.55	2.65	2.75
Overall Length	D	4.00 BSC		
Exposed Pad Length	D2	2.55	2.65	2.75
Contact Width	b	0.15	0.20	0.25
Contact Length	L	0.30	0.40	0.50
Contact-to-Exposed Pad	K	0.20	-	-

Notes:

1. Pin 1 visual index feature may vary, but must be located within the hatched area.
2. Package is saw singulated.
3. Dimensioning and tolerancing per ASME Y14.5M.

BSC: Basic Dimension. Theoretically exact value shown without tolerances.

REF: Reference Dimension, usually without tolerance, for information purposes only.

Microchip Technology Drawing C04-152A Sheet 2 of 2

PIC16(L)F18856/76

28-Lead Ultra Thin Plastic Quad Flat, No Lead Package (MV) - 4x4 mm Body [UQFN]
With 0.40 mm Contact Length

Note: For the most current package drawings, please see the Microchip Packaging Specification located at <http://www.microchip.com/packaging>

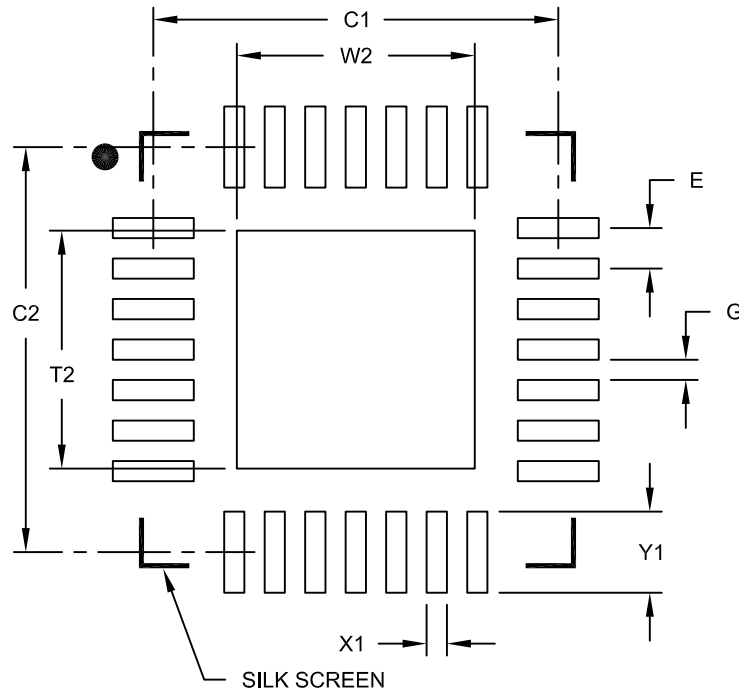

RECOMMENDED LAND PATTERN

Dimension Limits	Units	MILLIMETERS		
		MIN	NOM	MAX
Contact Pitch	E	0.40 BSC		
Optional Center Pad Width	W2			2.35
Optional Center Pad Length	T2			2.35
Contact Pad Spacing	C1		4.00	
Contact Pad Spacing	C2		4.00	
Contact Pad Width (X28)	X1			0.20
Contact Pad Length (X28)	Y1			0.80
Distance Between Pads	G	0.20		

Notes:

1. Dimensioning and tolerancing per ASME Y14.5M

BSC: Basic Dimension. Theoretically exact value shown without tolerances.

Microchip Technology Drawing No. C04-2152A

PIC16(L)F18856/76

40-Lead Plastic Dual In-Line (P) – 600 mil Body [PDIP]

Note: For the most current package drawings, please see the Microchip Packaging Specification located at <http://www.microchip.com/packaging>

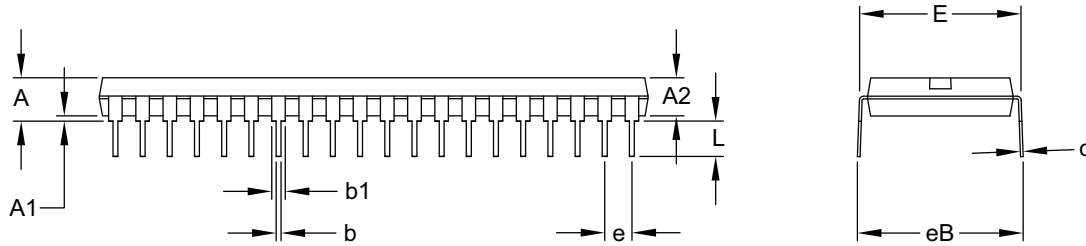
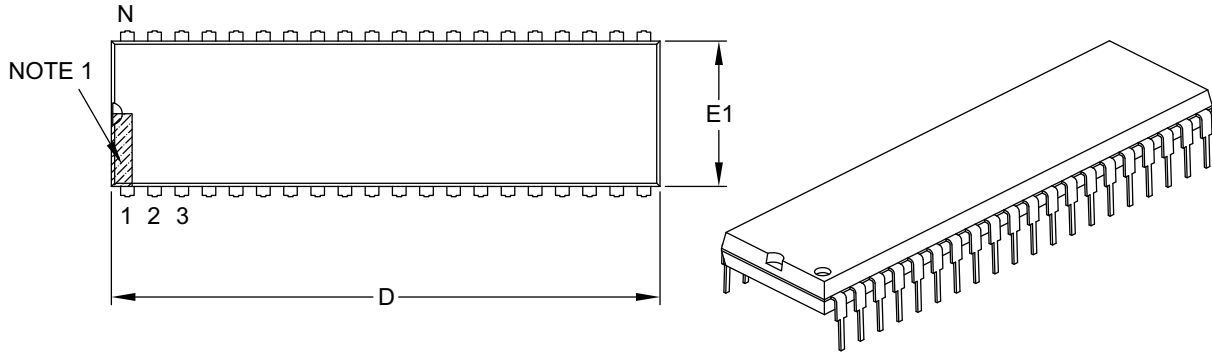

Dimension Limits	Units	INCHES		
		MIN	NOM	MAX
Number of Pins	N	40		
Pitch	e	.100 BSC		
Top to Seating Plane	A	–	–	.250
Molded Package Thickness	A2	.125	–	.195
Base to Seating Plane	A1	.015	–	–
Shoulder to Shoulder Width	E	.590	–	.625
Molded Package Width	E1	.485	–	.580
Overall Length	D	1.980	–	2.095
Tip to Seating Plane	L	.115	–	.200
Lead Thickness	c	.008	–	.015
Upper Lead Width	b1	.030	–	.070
Lower Lead Width	b	.014	–	.023
Overall Row Spacing §	eB	–	–	.700

Notes:

- Pin 1 visual index feature may vary, but must be located within the hatched area.
- § Significant Characteristic.
- Dimensions D and E1 do not include mold flash or protrusions. Mold flash or protrusions shall not exceed .010" per side.
- Dimensioning and tolerancing per ASME Y14.5M.

BSC: Basic Dimension. Theoretically exact value shown without tolerances.

Microchip Technology Drawing C04-016B

PIC16(L)F18856/76

40-Lead Ultra Thin Plastic Quad Flat, No Lead Package (MV) – 5x5x0.5 mm Body [UQFN]

Note: For the most current package drawings, please see the Microchip Packaging Specification located at <http://www.microchip.com/packaging>

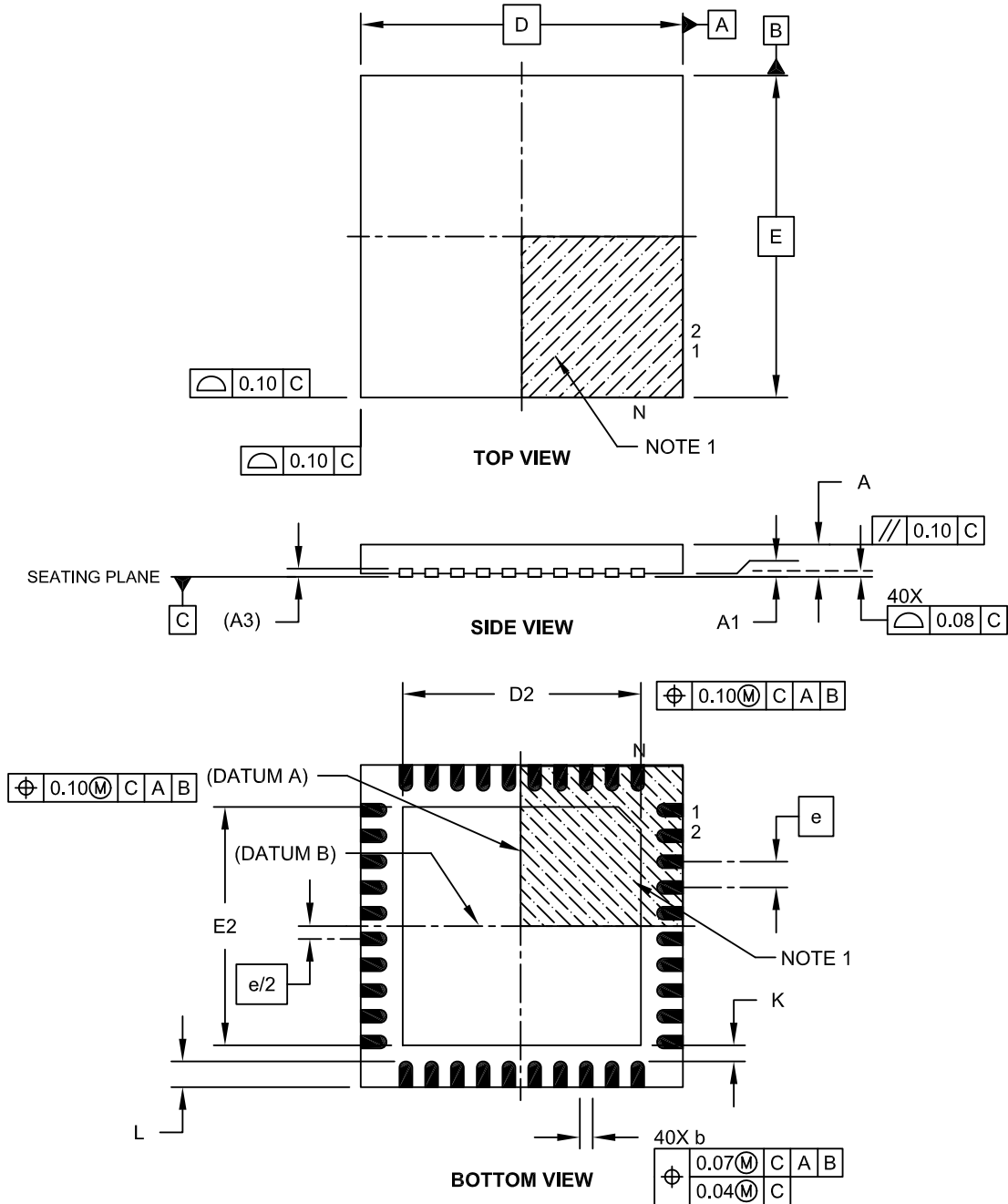

Microchip Technology Drawing C04-156A Sheet 1 of 2

PIC16(L)F18856/76

40-Lead Ultra Thin Plastic Quad Flat, No Lead Package (MV) – 5x5x0.5 mm Body [UQFN]

Note: For the most current package drawings, please see the Microchip Packaging Specification located at <http://www.microchip.com/packaging>

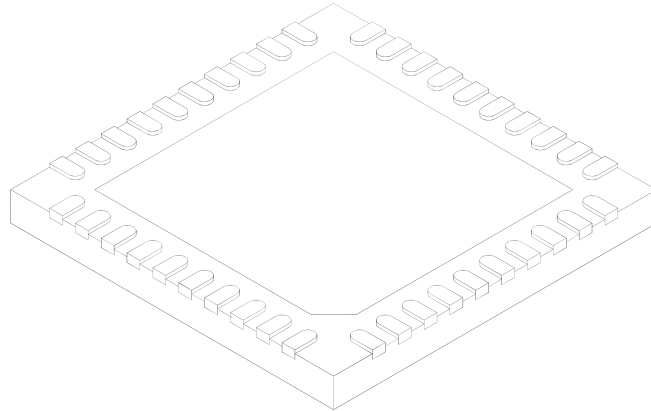

		Units	MILLIMETERS		
Dimension Limits			MIN	NOM	MAX
Number of Pins	N		40		
Pitch	e		0.40 BSC		
Overall Height	A		0.45	0.50	0.55
Standoff	A1		0.00	0.02	0.05
Contact Thickness	A3		0.127 REF		
Overall Width	E		5.00 BSC		
Exposed Pad Width	E2		3.60	3.70	3.80
Overall Length	D		5.00 BSC		
Exposed Pad Length	D2		3.60	3.70	3.80
Contact Width	b		0.15	0.20	0.25
Contact Length	L		0.30	0.40	0.50
Contact-to-Exposed Pad	K		0.20	-	-

Notes:

1. Pin 1 visual index feature may vary, but must be located within the hatched area.
2. Package is saw singulated.
3. Dimensioning and tolerancing per ASME Y14.5M.
BSC: Basic Dimension. Theoretically exact value shown without tolerances.
REF: Reference Dimension, usually without tolerance, for information purposes only.

Microchip Technology Drawing C04-156A Sheet 2 of 2

PIC16(L)F18856/76

40-Lead Plastic Ultra Thin Quad Flat, No Lead Package (MV) - 5x5 mm Body [UQFN]

Note: For the most current package drawings, please see the Microchip Packaging Specification located at <http://www.microchip.com/packaging>

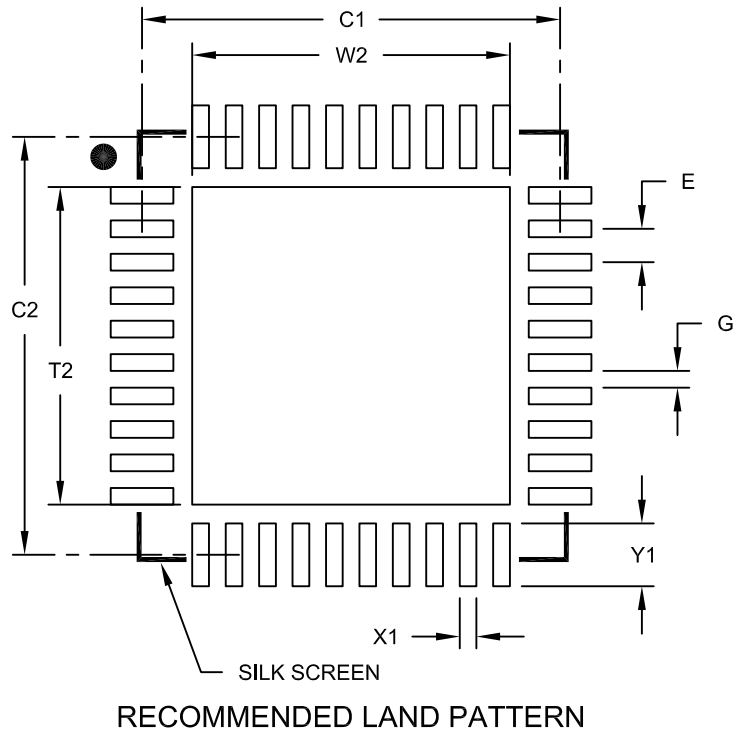

		Units	MILLIMETERS		
Dimension Limits			MIN	NOM	MAX
Contact Pitch	E		0.40 BSC		
Optional Center Pad Width	W2				3.80
Optional Center Pad Length	T2				3.80
Contact Pad Spacing	C1			5.00	
Contact Pad Spacing	C2			5.00	
Contact Pad Width (X40)	X1				0.20
Contact Pad Length (X40)	Y1				0.75
Distance Between Pads	G		0.20		

Notes:

1. Dimensioning and tolerancing per ASME Y14.5M

BSC: Basic Dimension. Theoretically exact value shown without tolerances.

Microchip Technology Drawing No. C04-2156B

PIC16(L)F18856/76

44-Lead Plastic Thin Quad Flatpack (PT) - 10x10x1.0 mm Body [TQFP]

Note: For the most current package drawings, please see the Microchip Packaging Specification located at <http://www.microchip.com/packaging>

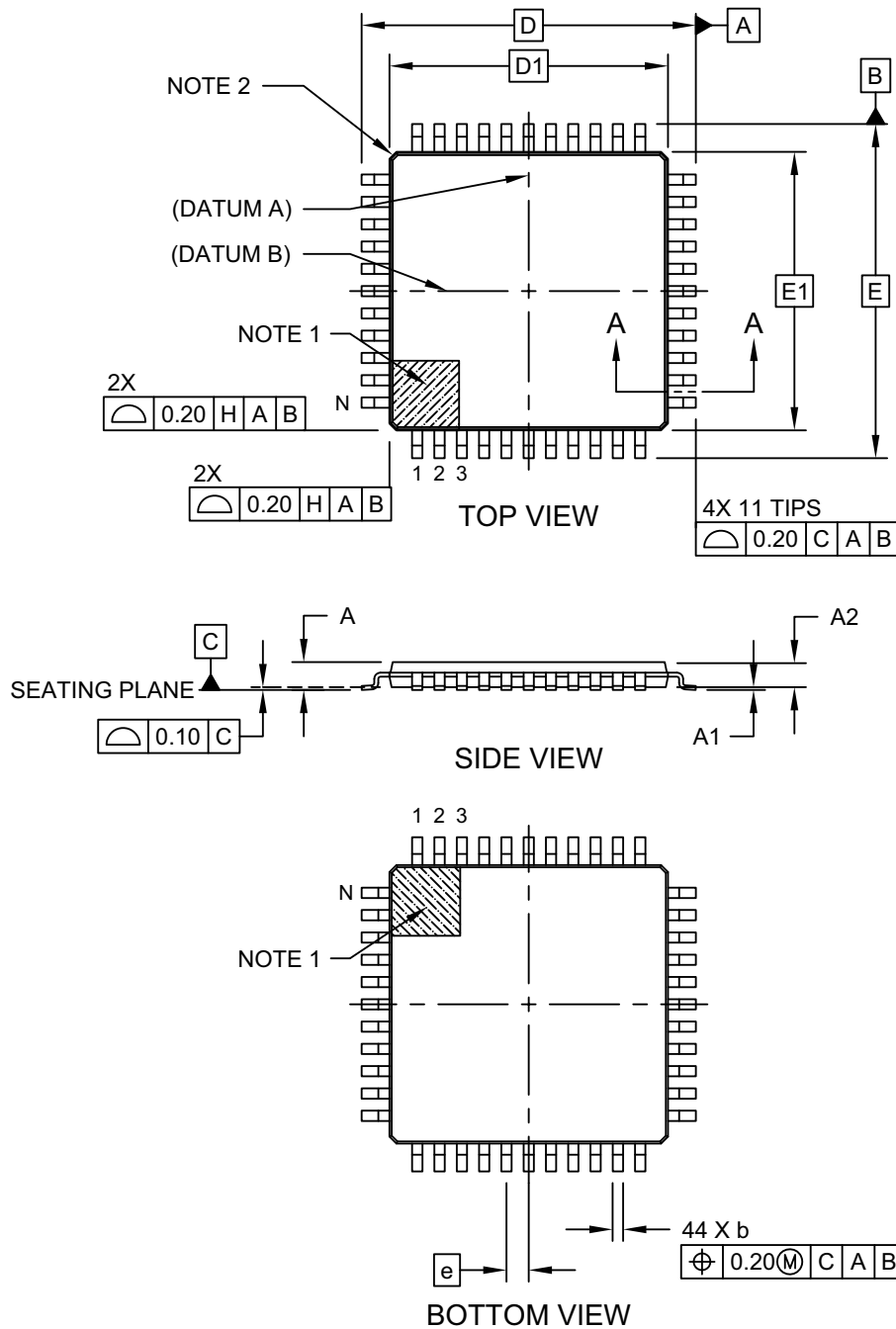

Microchip Technology Drawing C04-076C Sheet 1 of 2

PIC16(L)F18856/76

44-Lead Plastic Thin Quad Flatpack (PT) - 10x10x1.0 mm Body [TQFP]

Note: For the most current package drawings, please see the Microchip Packaging Specification located at <http://www.microchip.com/packaging>

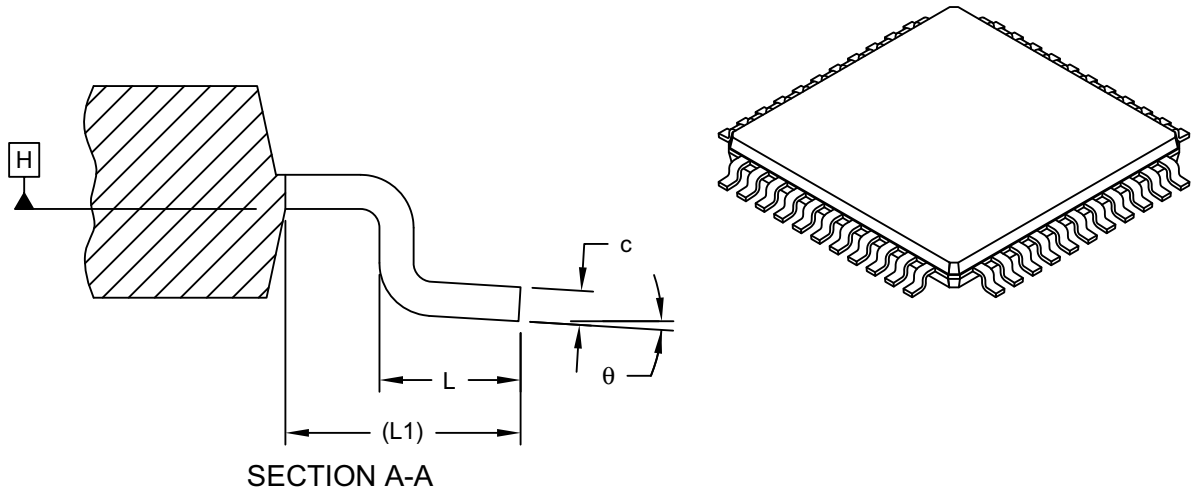

Dimension Limits	Units	MILLIMETERS		
		MIN	NOM	MAX
Number of Leads	N	44		
Lead Pitch	e	0.80 BSC		
Overall Height	A	-	-	1.20
Standoff	A1	0.05	-	0.15
Molded Package Thickness	A2	0.95	1.00	1.05
Overall Width	E	12.00 BSC		
Molded Package Width	E1	10.00 BSC		
Overall Length	D	12.00 BSC		
Molded Package Length	D1	10.00 BSC		
Lead Width	b	0.30	0.37	0.45
Lead Thickness	c	0.09	-	0.20
Lead Length	L	0.45	0.60	0.75
Footprint	L1	1.00 REF		
Foot Angle	θ	0°	3.5°	7°

Notes:

1. Pin 1 visual index feature may vary, but must be located within the hatched area.
2. Exact shape of each corner is optional.
3. Dimensioning and tolerancing per ASME Y14.5M

BSC: Basic Dimension. Theoretically exact value shown without tolerances.

REF: Reference Dimension, usually without tolerance, for information purposes only.

PIC16(L)F18856/76

44-Lead Plastic Thin Quad Flatpack (PT) - 10X10X1 mm Body, 2.00 mm Footprint [TQFP]

Note: For the most current package drawings, please see the Microchip Packaging Specification located at <http://www.microchip.com/packaging>

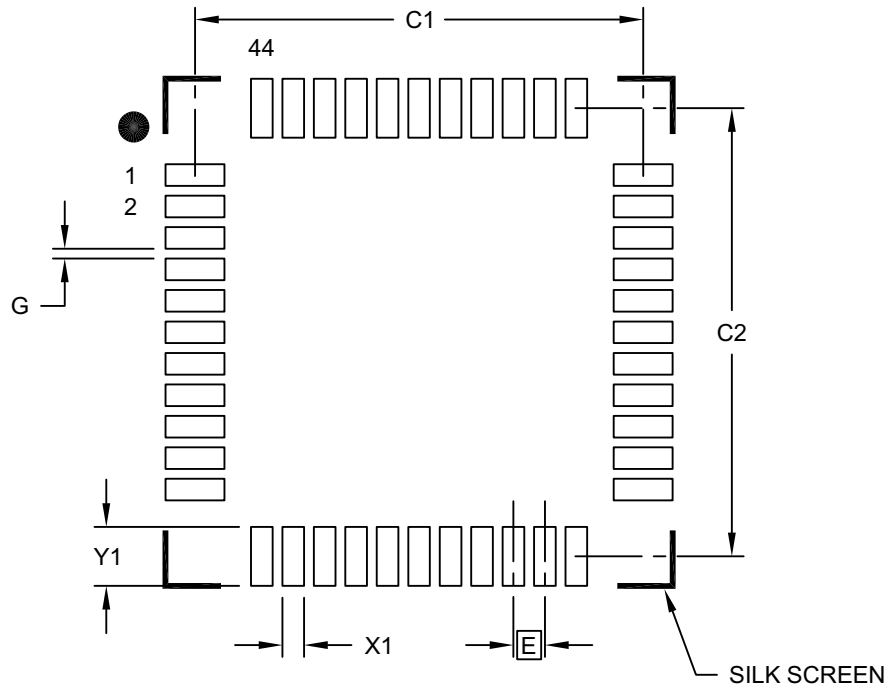

RECOMMENDED LAND PATTERN

Dimension Limits	Units	MILLIMETERS		
		MIN	NOM	MAX
Contact Pitch	E	0.80 BSC		
Contact Pad Spacing	C1		11.40	
Contact Pad Spacing	C2		11.40	
Contact Pad Width (X44)	X1			0.55
Contact Pad Length (X44)	Y1			1.50
Distance Between Pads	G	0.25		

Notes:

1. Dimensioning and tolerancing per ASME Y14.5M

BSC: Basic Dimension. Theoretically exact value shown without tolerances.

Microchip Technology Drawing No. C04-2076B

PIC16(L)F18856/76

44-Lead Plastic Quad Flat, No Lead Package (ML) - 8x8 mm Body [QFN]

Note: For the most current package drawings, please see the Microchip Packaging Specification located at <http://www.microchip.com/packaging>

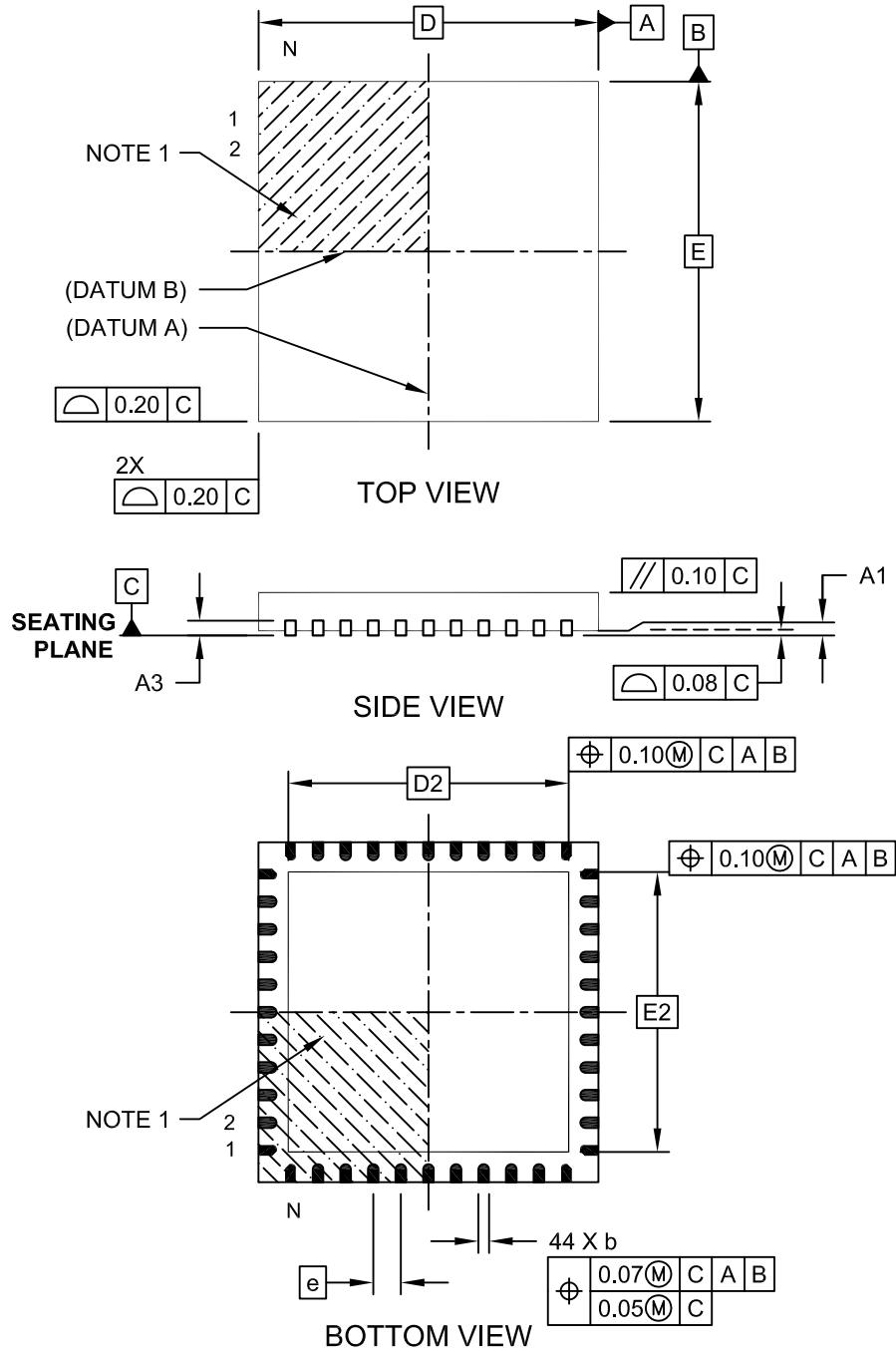

Microchip Technology Drawing C04-103C Sheet 1 of 2

PIC16(L)F18856/76

44-Lead Plastic Quad Flat, No Lead Package (ML) - 8x8 mm Body [QFN]

Note: For the most current package drawings, please see the Microchip Packaging Specification located at <http://www.microchip.com/packaging>

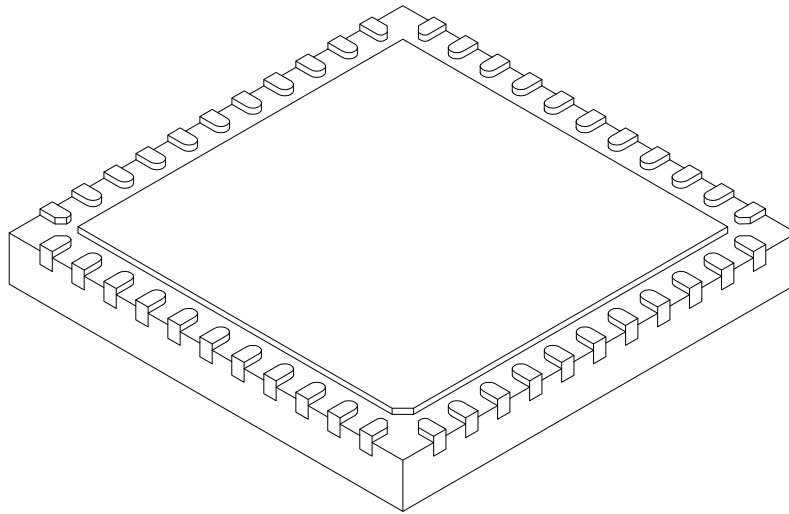

Dimension Limits	Units	MILLIMETERS		
		MIN	NOM	MAX
Number of Pins	N	44		
Pitch	e	0.65 BSC		
Overall Height	A	0.80	0.90	1.00
Standoff	A1	0.00	0.02	0.05
Terminal Thickness	A3	0.20 REF		
Overall Width	E	8.00 BSC		
Exposed Pad Width	E2	6.25	6.45	6.60
Overall Length	D	8.00 BSC		
Exposed Pad Length	D2	6.25	6.45	6.60
Terminal Width	b	0.20	0.30	0.35
Terminal Length	L	0.30	0.40	0.50
Terminal-to-Exposed-Pad	K	0.20	-	-

Notes:

1. Pin 1 visual index feature may vary, but must be located within the hatched area.
2. Package is saw singulated
3. Dimensioning and tolerancing per ASME Y14.5M

BSC: Basic Dimension. Theoretically exact value shown without tolerances.

REF: Reference Dimension. usually without tolerance. for information purposes only.

Microchip Technology Drawing C04-103C Sheet 2 of 2

PIC16(L)F18856/76

44-Lead Plastic Quad Flat, No Lead Package (ML) - 8x8 mm Body [QFN]

Note: For the most current package drawings, please see the Microchip Packaging Specification located at <http://www.microchip.com/packaging>

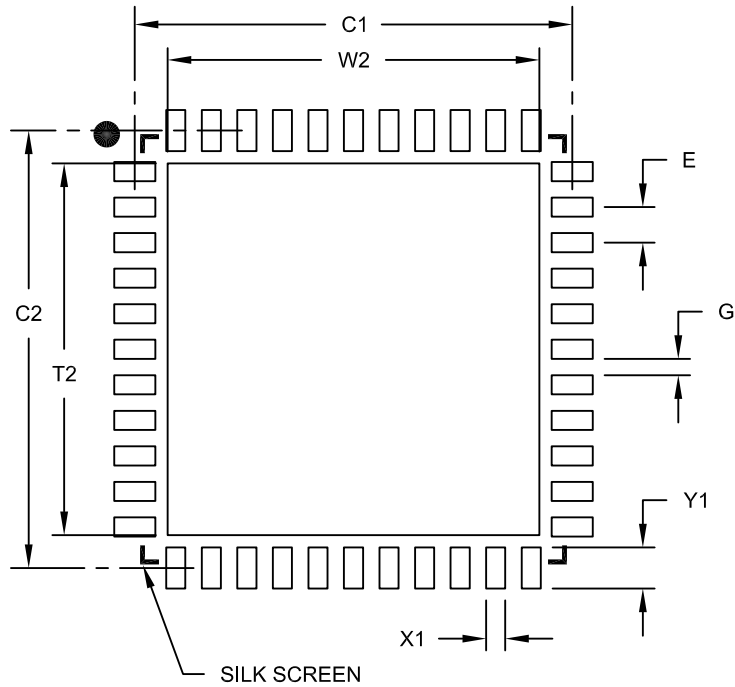

RECOMMENDED LAND PATTERN

Dimension Limits	Units	MILLIMETERS		
		MIN	NOM	MAX
Contact Pitch	E	0.65 BSC		
Optional Center Pad Width	W2			6.60
Optional Center Pad Length	T2			6.60
Contact Pad Spacing	C1		8.00	
Contact Pad Spacing	C2		8.00	
Contact Pad Width (X44)	X1			0.35
Contact Pad Length (X44)	Y1			0.85
Distance Between Pads	G	0.25		

Notes:

1. Dimensioning and tolerancing per ASME Y14.5M

BSC: Basic Dimension. Theoretically exact value shown without tolerances.

Microchip Technology Drawing No. C04-2103B

PIC16(L)F18856/76

APPENDIX A: DATA SHEET REVISION HISTORY

Revision A (01/2016)

Initial release of the document.

Revision B (04/2017)

Removed Preliminary Status - Added Char Graphs; Updated Figures 6-1, 23-2, 27-1, 28-1, 29-2, 29-3, 29-8, 29-9, 29-10, 29-11, 29-12, 29-13, 32-14, 32-15, 32-18, and 37-10; Registers 4-1, 4-3, 6-3, 8-2, 9-2, 12-2, 12-4, 12-6, 12-12, 12-14, 12-16, 12-32, 12-33, 12-34, 12-35, 12-36, 12-37, 12-43, 12-45, 12-49, 20-9, 23-1, 23-3, 23-4, 27-2, 28-1, 28-3, 29-1, 31-4, 31-5, 31-6, 34-1, and 34-2; Sections 9.1, 10.4.3, 21.5, 23.1.1, 23.1.4, 23.4.4, 23.5.2, 23.5.3, 29.1, 29.2, 31.6, 32.1.1, 32.6.9, 34.2, and 34.4; Tables 3-5, 3-6, 3-7, 10-2, 20-2, 23-1, 31-3, 36-4, 37-3, 37-5, 37-11 and 37-13.

Added Figure 37-11. Added Section 6.2.2.4 MFINTOSC, 21.5.1 Correction by AC Coupling. Added Section 28.4: Timer1 16-Bit Read/Write Mode.

Updated Instruction Sets MOVWF and NOP.

Removed Figure 37-11.

THE MICROCHIP WEBSITE

Microchip provides online support via our website at www.microchip.com. This website is used as a means to make files and information easily available to customers. Accessible by using your favorite Internet browser, the website contains the following information:

- **Product Support** – Data sheets and errata, application notes and sample programs, design resources, user's guides and hardware support documents, latest software releases and archived software
- **General Technical Support** – Frequently Asked Questions (FAQ), technical support requests, online discussion groups, Microchip consultant program member listing
- **Business of Microchip** – Product selector and ordering guides, latest Microchip press releases, listing of seminars and events, listings of Microchip sales offices, distributors and factory representatives

CUSTOMER CHANGE NOTIFICATION SERVICE

Microchip's customer notification service helps keep customers current on Microchip products. Subscribers will receive e-mail notification whenever there are changes, updates, revisions or errata related to a specified product family or development tool of interest.

To register, access the Microchip website at www.microchip.com. Under "Support", click on "Customer Change Notification" and follow the registration instructions.

CUSTOMER SUPPORT

Users of Microchip products can receive assistance through several channels:

- Distributor or Representative
- Local Sales Office
- Field Application Engineer (FAE)
- Technical Support

Customers should contact their distributor, representative or Field Application Engineer (FAE) for support. Local sales offices are also available to help customers. A listing of sales offices and locations is included in the back of this document.

Technical support is available through the website at: <http://www.microchip.com/support>

PIC16(L)F18856/76

PRODUCT IDENTIFICATION SYSTEM

To order or obtain information, e.g., on pricing or delivery, refer to the factory or the listed sales office.

<u>PART NO.</u>	<u>[X]⁽¹⁾</u>	-	<u>X</u>	<u>/XX</u>	<u>XXX</u>
Device	Tape and Reel Option		Temperature Range	Package	Pattern
<p>Device: PIC16F18856; PIC16LF18856; PIC16F18876; PIC16LF18876</p> <p>Tape and Reel Option: Blank = Standard packaging (tube or tray) T = Tape and Reel⁽¹⁾</p> <p>Temperature Range: I = -40°C to +85°C (Industrial) E = -40°C to +125°C (Extended)</p> <p>Package:⁽²⁾ ML = 28-lead QFN 6x6mm ML = 40-lead QFN 8x8mm MV = 28-lead UQFN 4x4x0.5mm MV = 40-lead UQFN 5x5x0.5mm P = 40-lead PDIP PT = 44-lead TQFP 10x10x1 SO = 28-lead SOIC SP = 28-lead SPDIP SS = 28-lead SSOP</p> <p>Pattern: QTP, SQTP, Code or Special Requirements (blank otherwise)</p>					
<p>Examples:</p> <p>a) PIC16F18856- E/SP Extended temperature SPDIP package</p> <p>b) PIC16F18876- I/P Industrial temperature PDIP package</p> <p>Note 1: Tape and Reel identifier only appears in the catalog part number description. This identifier is used for ordering purposes and is not printed on the device package. Check with your Microchip Sales Office for package availability with the Tape and Reel option.</p> <p>2: Small form-factor packaging options may be available. Please check www.microchip.com/packaging for small-form factor package availability, or contact your local Sales Office.</p>					

Note the following details of the code protection feature on Microchip devices:

- Microchip products meet the specification contained in their particular Microchip Data Sheet.
- Microchip believes that its family of products is one of the most secure families of its kind on the market today, when used in the intended manner and under normal conditions.
- There are dishonest and possibly illegal methods used to breach the code protection feature. All of these methods, to our knowledge, require using the Microchip products in a manner outside the operating specifications contained in Microchip's Data Sheets. Most likely, the person doing so is engaged in theft of intellectual property.
- Microchip is willing to work with the customer who is concerned about the integrity of their code.
- Neither Microchip nor any other semiconductor manufacturer can guarantee the security of their code. Code protection does not mean that we are guaranteeing the product as “unbreakable.”

Code protection is constantly evolving. We at Microchip are committed to continuously improving the code protection features of our products. Attempts to break Microchip's code protection feature may be a violation of the Digital Millennium Copyright Act. If such acts allow unauthorized access to your software or other copyrighted work, you may have a right to sue for relief under that Act.

Information contained in this publication regarding device applications and the like is provided only for your convenience and may be superseded by updates. It is your responsibility to ensure that your application meets with your specifications. MICROCHIP MAKES NO REPRESENTATIONS OR WARRANTIES OF ANY KIND WHETHER EXPRESS OR IMPLIED, WRITTEN OR ORAL, STATUTORY OR OTHERWISE, RELATED TO THE INFORMATION, INCLUDING BUT NOT LIMITED TO ITS CONDITION, QUALITY, PERFORMANCE, MERCHANTABILITY OR FITNESS FOR PURPOSE. Microchip disclaims all liability arising from this information and its use. Use of Microchip devices in life support and/or safety applications is entirely at the buyer's risk, and the buyer agrees to defend, indemnify and hold harmless Microchip from any and all damages, claims, suits, or expenses resulting from such use. No licenses are conveyed, implicitly or otherwise, under any Microchip intellectual property rights unless otherwise stated.

Microchip received ISO/TS-16949:2009 certification for its worldwide headquarters, design and wafer fabrication facilities in Chandler and Tempe, Arizona; Gresham, Oregon and design centers in California and India. The Company's quality system processes and procedures are for its PIC[®] MCUs and dsPIC[®] DSCs, KEELoQ[®] code hopping devices, Serial EEPROMs, microperipherals, nonvolatile memory and analog products. In addition, Microchip's quality system for the design and manufacture of development systems is ISO 9001:2000 certified.

**QUALITY MANAGEMENT SYSTEM
CERTIFIED BY DNV
= ISO/TS 16949 =**

Trademarks

The Microchip name and logo, the Microchip logo, AnyRate, AVR, AVR logo, AVR Freaks, BeaconThings, BitCloud, chipKIT, chipKIT logo, CryptoMemory, CryptoRF, dsPIC, FlashFlex, flexPWR, Helder, JukeBlox, KEELoQ, KEELoQ logo, Kleer, LANCheck, LINK MD, maXStylus, maXTouch, MedialB, megaAVR, MOST, MOST logo, MPLAB, OptoLyzer, PIC, picoPower, PICSTART, PIC32 logo, Prochip Designer, QTouch, RightTouch, SAM-BA, SpyNIC, SST, SST Logo, SuperFlash, tinyAVR, UNI/O, and XMEGA are registered trademarks of Microchip Technology Incorporated in the U.S.A. and other countries.

ClockWorks, The Embedded Control Solutions Company, EtherSynch, Hyper Speed Control, HyperLight Load, IntelliMOS, mTouch, Precision Edge, and Quiet-Wire are registered trademarks of Microchip Technology Incorporated in the U.S.A.

Adjacent Key Suppression, AKS, Analog-for-the-Digital Age, Any Capacitor, AnyIn, AnyOut, BodyCom, CodeGuard, CryptoAuthentication, CryptoCompanion, CryptoController, dsPICDEM, dsPICDEM.net, Dynamic Average Matching, DAM, ECAN, EtherGREEN, In-Circuit Serial Programming, ICSP, Inter-Chip Connectivity, JitterBlocker, KleerNet, KleerNet logo, Mindi, MiWi, motorBench, MPASM, MPF, MPLAB Certified logo, MPLIB, MPLINK, MultiTRAK, NetDetach, Omniscient Code Generation, PICDEM, PICDEM.net, PICKit, PICtail, PureSilicon, QMatrix, RightTouch logo, REAL ICE, Ripple Blocker, SAM-ICE, Serial Quad I/O, SMART-I.S., SQI, SuperSwitcher, SuperSwitcher II, Total Endurance, TSHARC, USBCheck, VariSense, ViewSpan, WiperLock, Wireless DNA, and ZENA are trademarks of Microchip Technology Incorporated in the U.S.A. and other countries.

SQTP is a service mark of Microchip Technology Incorporated in the U.S.A.

Silicon Storage Technology is a registered trademark of Microchip Technology Inc. in other countries.

GestIC is a registered trademark of Microchip Technology Germany II GmbH & Co. KG, a subsidiary of Microchip Technology Inc., in other countries.

All other trademarks mentioned herein are property of their respective companies.

© 2016-2017, Microchip Technology Incorporated, All Rights Reserved.

ISBN: 978-1-5224-1628-9

Worldwide Sales and Service

AMERICAS

Corporate Office
2355 West Chandler Blvd.
Chandler, AZ 85224-6199
Tel: 480-792-7200
Fax: 480-792-7277
Technical Support:
<http://www.microchip.com/support>
Web Address:
www.microchip.com

Atlanta
Duluth, GA
Tel: 678-957-9614
Fax: 678-957-1455

Austin, TX
Tel: 512-257-3370

Boston
Westborough, MA
Tel: 774-760-0087
Fax: 774-760-0088

Chicago
Itasca, IL
Tel: 630-285-0071
Fax: 630-285-0075

Dallas
Addison, TX
Tel: 972-818-7423
Fax: 972-818-2924

Detroit
Novi, MI
Tel: 248-848-4000

Houston, TX
Tel: 281-894-5983

Indianapolis
Noblesville, IN
Tel: 317-773-8323
Fax: 317-773-5453
Tel: 317-536-2380

Los Angeles
Mission Viejo, CA
Tel: 949-462-9523
Fax: 949-462-9608
Tel: 951-273-7800

Raleigh, NC
Tel: 919-844-7510

New York, NY
Tel: 631-435-6000

San Jose, CA
Tel: 408-735-9110
Tel: 408-436-4270

Canada - Toronto
Tel: 905-695-1980
Fax: 905-695-2078

ASIA/PACIFIC

Asia Pacific Office
Suites 3707-14, 37th Floor
Tower 6, The Gateway
Harbour City, Kowloon

Hong Kong
Tel: 852-2943-5100
Fax: 852-2401-3431

Australia - Sydney
Tel: 61-2-9868-6733
Fax: 61-2-9868-6755

China - Beijing
Tel: 86-10-8569-7000
Fax: 86-10-8528-2104

China - Chengdu
Tel: 86-28-8665-5511
Fax: 86-28-8665-7889

China - Chongqing
Tel: 86-23-8980-9588
Fax: 86-23-8980-9500

China - Dongguan
Tel: 86-769-8702-9880

China - Guangzhou
Tel: 86-20-8755-8029

China - Hangzhou
Tel: 86-571-8792-8115
Fax: 86-571-8792-8116

China - Hong Kong SAR
Tel: 852-2943-5100
Fax: 852-2401-3431

China - Nanjing
Tel: 86-25-8473-2460
Fax: 86-25-8473-2470

China - Qingdao
Tel: 86-532-8502-7355
Fax: 86-532-8502-7205

China - Shanghai
Tel: 86-21-3326-8000
Fax: 86-21-3326-8021

China - Shenyang
Tel: 86-24-2334-2829
Fax: 86-24-2334-2393

China - Shenzhen
Tel: 86-755-8864-2200
Fax: 86-755-8203-1760

China - Wuhan
Tel: 86-27-5980-5300
Fax: 86-27-5980-5118

China - Xian
Tel: 86-29-8833-7252
Fax: 86-29-8833-7256

ASIA/PACIFIC

China - Xiamen
Tel: 86-592-2388138
Fax: 86-592-2388130

China - Zhuhai
Tel: 86-756-3210040
Fax: 86-756-3210049

India - Bangalore
Tel: 91-80-3090-4444
Fax: 91-80-3090-4123

India - New Delhi
Tel: 91-11-4160-8631
Fax: 91-11-4160-8632

India - Pune
Tel: 91-20-3019-1500

Japan - Osaka
Tel: 81-6-6152-7160
Fax: 81-6-6152-9310

Japan - Tokyo
Tel: 81-3-6880-3770
Fax: 81-3-6880-3771

Korea - Daegu
Tel: 82-53-744-4301
Fax: 82-53-744-4302

Korea - Seoul
Tel: 82-2-554-7200
Fax: 82-2-558-5932 or
82-2-558-5934

Malaysia - Kuala Lumpur
Tel: 60-3-6201-9857
Fax: 60-3-6201-9859

Malaysia - Penang
Tel: 60-4-227-8870
Fax: 60-4-227-4068

Philippines - Manila
Tel: 63-2-634-9065
Fax: 63-2-634-9069

Singapore
Tel: 65-6334-8870
Fax: 65-6334-8850

Taiwan - Hsin Chu
Tel: 886-3-5778-366
Fax: 886-3-5770-955

Taiwan - Kaohsiung
Tel: 886-7-213-7830

Taiwan - Taipei
Tel: 886-2-2508-8600
Fax: 886-2-2508-0102

Thailand - Bangkok
Tel: 66-2-694-1351
Fax: 66-2-694-1350

EUROPE

Austria - Wels
Tel: 43-7242-2244-39
Fax: 43-7242-2244-393

Denmark - Copenhagen
Tel: 45-4450-2828
Fax: 45-4485-2829

Finland - Espoo
Tel: 358-9-4520-820

France - Paris
Tel: 33-1-69-53-63-20
Fax: 33-1-69-30-90-79

France - Saint Cloud
Tel: 33-1-30-60-70-00

Germany - Garching
Tel: 49-8931-9700

Germany - Haan
Tel: 49-2129-3766400

Germany - Heilbronn
Tel: 49-7131-67-3636

Germany - Karlsruhe
Tel: 49-721-625370

Germany - Munich
Tel: 49-89-627-144-0
Fax: 49-89-627-144-44

Germany - Rosenheim
Tel: 49-8031-354-560

Israel - Ra'anana
Tel: 972-9-744-7705

Italy - Milan
Tel: 39-0331-742611
Fax: 39-0331-466781

Italy - Padova
Tel: 39-049-7625286

Netherlands - Drunen
Tel: 31-416-690399
Fax: 31-416-690340

Norway - Trondheim
Tel: 47-7289-7561

Poland - Warsaw
Tel: 48-22-3325737

Romania - Bucharest
Tel: 40-21-407-87-50

Spain - Madrid
Tel: 34-91-708-08-90
Fax: 34-91-708-08-91

Sweden - Gothenberg
Tel: 46-31-704-60-40

Sweden - Stockholm
Tel: 46-8-5090-4654

UK - Wokingham
Tel: 44-118-921-5800
Fax: 44-118-921-5820

X-ON Electronics

Largest Supplier of Electrical and Electronic Components

Click to view similar products for [8-bit Microcontrollers - MCU category](#):

Click to view products by [Microchip manufacturer](#):

Other Similar products are found below :

[009936B](#) [CY8C20524-12PVXIT](#) [CY8C28433-24PVXIT](#) [MB95F012KPFT-G-SNE2](#) [MB95F013KPMC-G-SNE2](#) [MB95F263KPF-G-SNE2](#)
[MB95F264KPFT-G-SNE2](#) [MB95F398KPMC-G-SNE2](#) [MB95F478KPMC2-G-SNE2](#) [MB95F562KPF-G-SNE2](#) [MB95F564KPF-G-SNE2](#)
[MB95F634KPMC-G-SNE2](#) [MB95F636KWQN-G-SNE1](#) [MB95F696KPMC-G-SNE2](#) [MB95F698KPMC1-G-SNE2](#) [MB95F698KPMC2-G-](#)
[SNE2](#) [MB95F698KPMC-G-SNE2](#) [MB95F818KPMC1-G-SNE2](#) [MC908JK1ECDWER](#) [MC9S08PA32AVLD](#) [MC9S08PT60AVLD](#)
[R5F1076CMSPV0](#) [R5F5631ECDFBV0](#) [C8051F389-B-GQ](#) [C8051F392-A-GMR](#) [ISD-ES1600_USB_PROG](#) [901015X](#) [S9S08SL8F1CTJR](#)
[STM8TL53G4U6](#) [PIC16F877-04/P-B](#) [R5F10Y17ASP#30](#) [CY8C3MFIDOCK-125](#) [403708R](#) [MB95F354EPF-G-SNE2](#) [MB95F564KPFT-G-](#)
[SNE2](#) [MB95F564KWQN-G-SNE1](#) [MB95F636KP-G-SH-SNE2](#) [MB95F636KPMC-G-SNE2](#) [MB95F694KPMC-G-SNE2](#) [MB95F778JPMC1-](#)
[G-SNE2](#) [MB95F818KPMC-G-SNE2](#) [MC908QY8CDWER](#) [MC9S08PT16AVLD](#) [MC9S08PT32AVLH](#) [MC9S08PT60AVLC](#)
[MC9S08PT60AVLH](#) [C8051F500-IQR](#) [400801H](#) [LC87F0G08AUJA-AH](#) [026923G](#)