

# SEPA<sup>®</sup> RADIAL FAN

HY\_60Q05AP

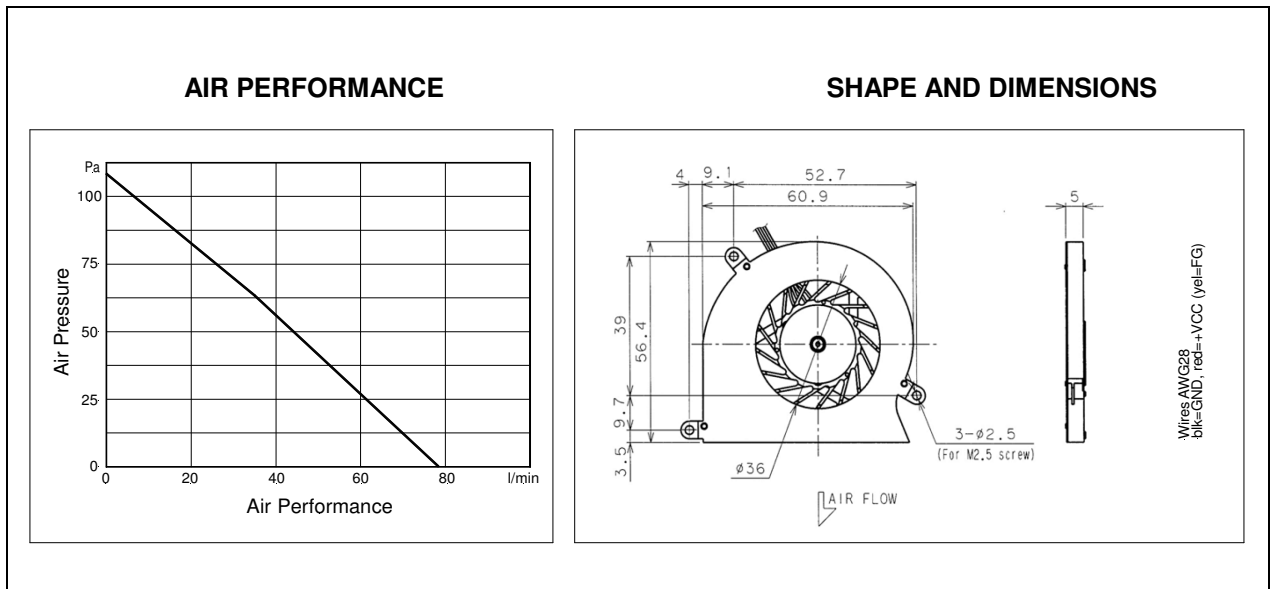

## HIGH PERFORMANCE FAN



## PERFORMANCE

CE		HY_60Q05AP
Operating Voltage	[VDC]	4.5 ... 5.0 ... 5.5
Typ. Operating Current	[mA]	140
Max. Start Current	[mA]	400
Max. Air Flow	[l/min - m <sup>3</sup> /h]	78 – 4.69
Max. Pressure	[mmH <sub>2</sub> O - Pa]	10.7 – 105
Noise @ 1m (typ.)	[dB(A)]	28
Operating Temperature	[°C]	-10 ... +60
Typ. Rotor Speed	[RPM]	4400
FG Output	[PPR]	2
PWM Signal (Frequency, Duty Cycle)	[VDC]	0.7 ... 2.5 (23KHz, 30...100%)
Life Expectancy L <sub>10</sub> /MTBF	[h]	75000/225000 @20°C
Bearing System		Magfix Sleeve Bearing
Weight	[g]	18
Packing Quantity	[Pc]	50-500

This **SEPA<sup>®</sup>** high-tech miniature fan is suitable for industrial and has a remarkable air flow performance despite its small dimensions. The air intake is on the top and on the bottom side, the air exit is on the side. The fan is permanently electrically protected against reverse polarity, blocking and thermal overloading. Due to the low rotor weight and precision balancing, it is virtually vibration-free. It is also insensitive to shock.

Further features of this fan are its extremely robust and torsionally stiff housing of PBT (UL E54695) with metal base, long-life-sleeve bearing with very high oil volume, polyester-based PCB (UL E44247) and absolute reliability due to a 100% burn-in.

## • ALAR OUTPUT

The **SEPA**<sup>®</sup>-fan HY\_60Q05AP includes a speed impulse output (FG) which enables monitoring the correct function of the fan.

The pulse is like a rectangular wave, the frequency correlates to 2 x rotor speed. At blocked rotor the output signal could be L ( $\leq 0,2V$ ) or H ( $V_{cc}$ ).

**IMPORTANT:** The pulse output is not protected against short circuit and must not connect to GND or  $V_{cc}$  without pre-resistor. A pull-up-resistor is needed.

The **SEPA**<sup>®</sup>-fan HY\_60QAP has a **PWM** control input ( $L=0.7V_{max}$ ;  $H=2.5...V_{cc}$ ;  $f=23\text{ kHz}$ ). Start-up PWM duty percentage 35% min, frequency of PWM duty cycle 23 KHz, range of PWM duty cycle 35...100%.

Do not inputs a PWM input signal if the fan power supply is off! Otherwise the fan will be destroyed. Please follow the handling instructions.

The fan has tinned lead wire ends (without connector).

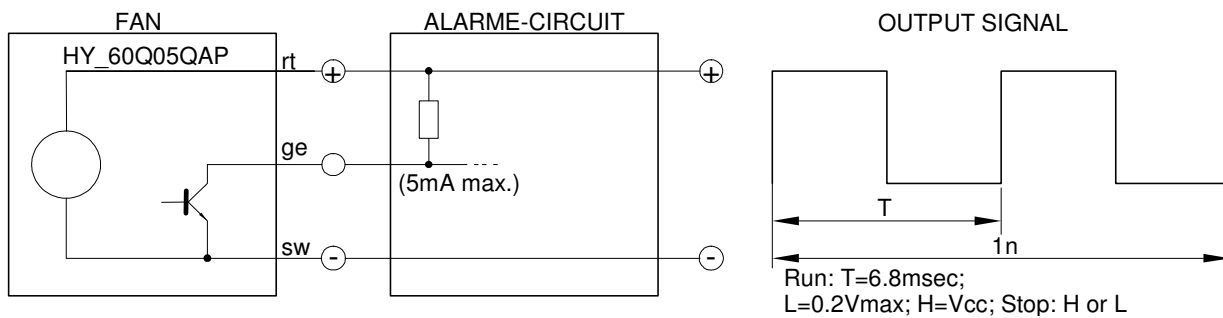

## • ACCESSORIES:

CONNECTOR: on request

## • ORDER INFORMATION:

HY\_60Q05AP **SEPA** Radial fan, 60x60x12.5mm, 5VDC, Long-Life-Sleeve bearing, **CE** 1060Q1040

**SEPA**<sup>®</sup> is the brand name for fans and CPU-Cooler, made by Nippon Keiki Works LTD., Tokyo

## **X-ON Electronics**

Largest Supplier of Electrical and Electronic Components

*Click to view similar products for [sepa](#) manufacturer:*

Other Similar products are found below :

[HXB50E12](#) [MFB60D05](#) [MFB25B05](#) [FG80](#) [FM40](#) [FG40](#) [MFB50E12](#) [HFB44B12A](#) [MFB40H12A](#) [FG92](#) [MFB40H12](#) [FG30](#) [FG50](#) [FM120](#)  
[FM80](#)