

iC-WKM

M-TYPE CW LASER DIODE DRIVER

preliminary



Rev C1, Page 1/9

FEATURES

- ◆ Optimised for M-type laser diodes (single supply, case grounded)
- ◆ CW operation up to 350 mA from a single supply of 3.6 to 15 V
- ◆ Rapid soft start after power-on
- ◆ Simple power adjustment via an external resistor
- ◆ Integrated reverse polarity protection for the iC and laser diode
- ◆ Strong suppression of transients with small external capacitors; integrated flyback path
- ◆ Permanent shutdown with excessive temperature and overcurrent (i.e. if the laser diode is damaged or the feedback current path fails)
- ◆ Two feedback inputs permit all current laser diode types to be used (M/P/N configurations)
- ◆ Modulation via the feedback inputs possible
- ◆ Wide monitor current range from 2.5 μ A to 6.25 mA

APPLICATIONS

- ◆ Blue laser diodes
- ◆ Laser diode modules
- ◆ Laser diode pointers
- ◆ Laser levels
- ◆ Bar-code readers

PACKAGES

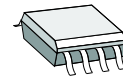

SO8tp
thermal pad



DFN10
4 mm x 4 mm

BLOCK DIAGRAM

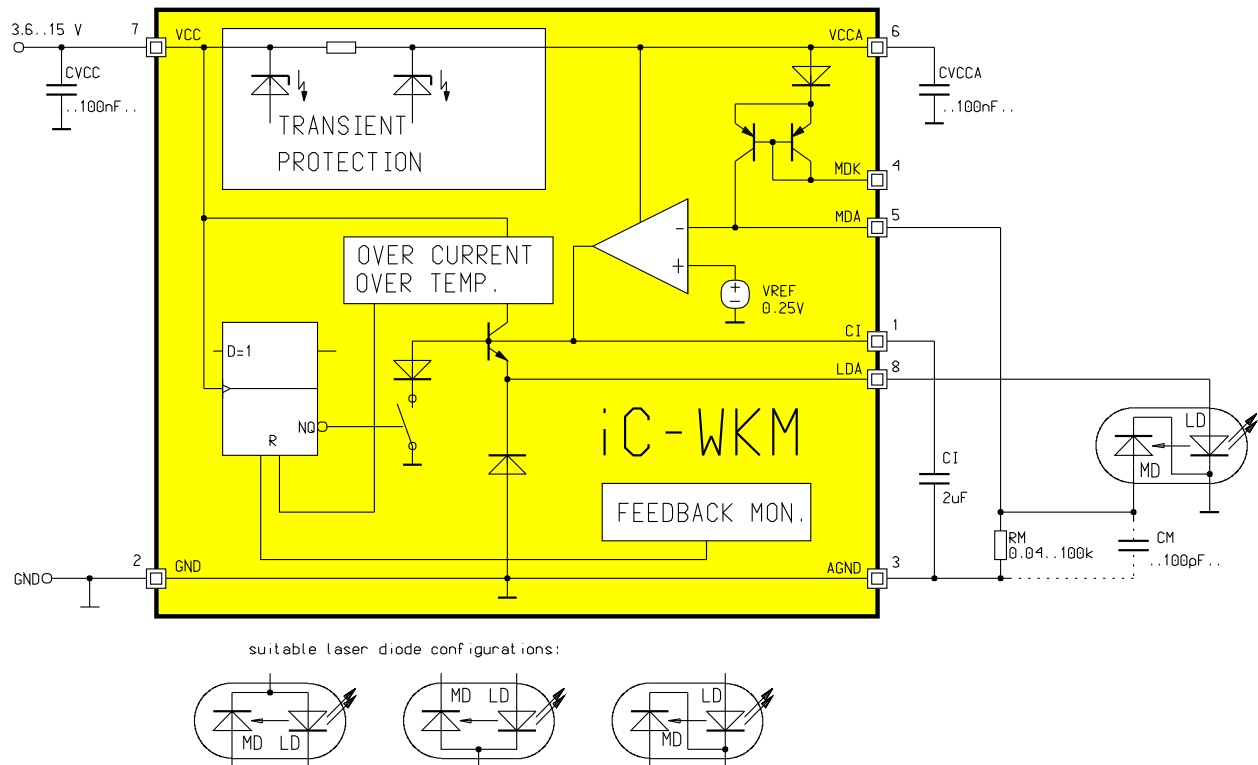

Pin numbers given for SO8 package only.

iC-WKM

M-TYPE CW LASER DIODE DRIVER

DESCRIPTION

iC-WKM is a driver for laser diodes in continuous wave operation with laser currents of up to 350 mA, which requires only four external components. The wide power supply range of up to 15 V allows for operation of blue laser diodes, e.g. by Nichia or Sanyo. The driver is optimised for M-type laser diodes and allows the operation from a single supply and the connection of the laser diode case (common cathode) with ground.

The iC includes integrated circuitry protecting against destruction by ESD, excessive temperature and overcurrent plus a soft start of the regulator to protect the laser diode when the power supply is switched on. The iC also filters the laser diode power supply for transients.

The regulator is adapted to the laser diode by an external resistor at MDA. The monitor current acts as a reference and is regulated independent of the influence of temperature and supply voltage (range:

2.5 μ A to 6.25 mA). The capacitor at CI determines the control time constants and start-up time.

A second monitor input, pin MDK, allows the driver to be used for P-type laser diode configuration; alternatively, it can be used as an analogue modulation input (DC to a few kHz).

In the event of failure, such as overcurrent in the laser path with a lack of feedback, for example, a quick power lockout is activated. The shutdown persists until power is reapplied, permitting a restart. The strain on power packs and batteries is relieved and the laser class is retained even in the event of a disturbance.

iC-WKM offers additional protection by means of spike detection at pin MDA. Should spikes or oscillation occur at pin MDA the power lockout is activated after a certain time-out.

iC-WKM

M-TYPE CW LASER DIODE DRIVER

PACKAGES SO8tp, DFN10 4 mm x 4 mm to JEDEC standard

PIN CONFIGURATION SO8tp (top view)

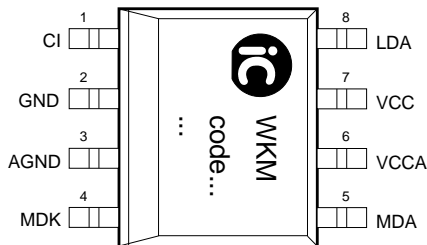

PIN FUNCTIONS

No.	Name	Function
1	CI	Capacitor for Power Control
2	GND	Ground
3	AGND	Reference Ground for CI, RM
4	MDK	Monitor Input 2 (MD Cathode, modulation)
5	MDA	APC Setup, Monitor Input 1 (MD Anode)
6	VCCA	Driver Supply
7	VCC	+3.6 to 15 V Supply Voltage
8	LDA	Driver Output (LD Anode)

The *Thermal Pad* is to be connected to a Ground Plane on the PCB. Do not short-circuit pins AGND and GND, for this may deteriorate the precision of the regulator and interfere with the soft-start!

PIN CONFIGURATION DFN10 4 mm x 4 mm (top view)

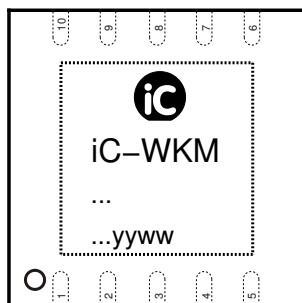

PIN FUNCTIONS

No.	Name	Function
1	CI	Capacitor for Power Control
2	GND	Ground
3	AGND	Reference Ground for CI, RM
4	MDK	Monitor Input 2 (MD Cathode, modulation)
5	n.c.	
6	MDA	APC Setup, Monitor Input 1 (MD Anode)
7	VCCA	Driver Supply
8	VCC	+3.6 to 15 V Supply Voltage
9	LDA	Driver Output (LD Anode)
10	n.c.	

The *Thermal Pad* is to be connected to a Ground Plane on the PCB. Do not short-circuit pins AGND and GND, for this may deteriorate the precision of the regulator and interfere with the soft-start!

iC-WKM

M-TYPE CW LASER DIODE DRIVER



Rev C1, Page 4/9

ABSOLUTE MAXIMUM RATINGS

Beyond these values damage may occur; device operation is not guaranteed.

Item No.	Symbol	Parameter	Conditions	Fig.			Unit
					Min.	Max.	
G001	VCC	Voltage at VCC			-6	16	V
G002	I(VCC)	Current in VCC			-10	900	mA
G003	I(CI)	Current in CI			-10	10	mA
G004	I(LDA)	Current in LDA			-900	10	mA
G005	I(VCCA)	Current in VCCA			-10	10	mA
G006	I(MDA)	Current in MDA			-10	10	mA
G007	I(MDK)	Current in MDK			-10	10	mA
G008	I(AGND)	Current in AGND			-10	10	mA
G009	I(GND)	Current in GND			-10	900	mA
G010	Vd()	ESD Susceptibility at all pins	MIL-STD-833, method 3015, HBM 100 pF discharged via 1.5 kΩ			2	kV
G011	Tj	Operating Junction Temperature			-40	150	°C
G012	Ts	Storage Temperature Range			-40	150	°C

THERMAL DATA

Operating Conditions: VCC = 3.6...15 V

Item No.	Symbol	Parameter	Conditions	Fig.				Unit
					Min.	Typ.	Max.	
T01	Ta	Operating Ambient Temperature Range			-40		85	°C
T02	Rthja	Thermal Resistance Chip/Ambient	SMD assembly, no additional cooling areas				170	K/W
T03	Rthja	Thermal Resistance Chip/Ambient	therm. pad soldered to approx. 2 cm ² cooling area			30	50	K/W

All voltages are referenced to ground unless otherwise stated.

All currents into the device pins are positive; all currents out of the device pins are negative.

ELECTRICAL CHARACTERISTICS

Operating Conditions: VCC = 3.6...15 V, RM = 40 Ω...100 kΩ, Tj = -40...125 °C unless otherwise noted

Item No.	Symbol	Parameter	Conditions	Tj °C	Fig.				Unit
						Min.	Typ.	Max.	
Total Device									
001	VCC	Permissible Supply Voltage				3.6		15	V
002	I(LDA)m	Permissible Laser Drive Current	control range			-350		-10	mA
003	Idc(VCC)	Supply Current without load path	closed control loop, I(MDK) = 0, I(LDA) = 350 mA				5	10	mA
004	Ioff(VCC)	Supply Current after Reset					2.4	5	mA
005	Ir(VCC)	Reverse Supply Current	RM = 50 kΩ, VCC = -6 V			-10	-3		mA
006	ton()	Turn-on Delay	VCC: 0 → 5 V to 95%I(LDA); I(LDA) = I(LDA)m, CI = 3.3 μF					600	μs
007	Vc()hi	Clamp Voltage hi at MDA	I() = 10 mA, other pins open			1.1		4	V
008	Vc()lo	Clamp Voltage lo at VCC, LDA, MDA, CI, VCCA	I() = -10 mA, other pins open			-9			V
009	Vc()hi	Clamp Voltage hi at MDK referenced to VCCA	I() = 10 mA, other pins open			6		11	V
010	Vc()lo	Clamp Voltage lo at MDK referenced to VCCA	I() = -10 mA, other pins open			-11		-1	V
011	Vc()hi	Clamp Voltage hi at VCC, LDA, CI, VCCA	I() = 10 mA, other pins open			16		24	V
Reference and Monitor Inputs MDA, MDK, AGND									
101	V(MDA)	Reference Voltage at MDA	closed control loop, V(LDA) < Vs(LDA)			230	250	270	mV
102	dV(MDA)	Reference Voltage Temperature Drift at MDA	see 101					120	μV/°C
103	Ierr(MDA)	Input Current in MDA	closed control loop, I(MDK) = 0			-100		100	nA
104	dI(MDA)	Input Current Temperature Drift in MDA	see 103			-1		1	nA/°C
105	APCerr	Control Error	RM = 10 kΩ; Tj = 0...80 °C Tj = -40...125 °C					0.5 2	% %
106	dI(MD)	Supply Voltage Suppression	V(VCC): 3.6 V → 15 V, I(LDA) = -350 mA			-4		4	%
107	Rgnd()	Resistor AGND-GND						3	Ω
108	CR()	Current Ratio I(MDA)/I(MDK)	I(MDK) = 1...500 μA I(MDK) = 0.5...3 mA I(MDK) = 3...6 mA			0.97 0.95 0.92		1.03 1.05 1.06	
109	TC()	Current Ratio Temperature Coefficient I(MDA)/I(MDK)	I(MDK) = 1 μA...1 mA			-0.005		0.005	%/°C
110	TC()	Current Ratio Temperature Coefficient I(MDA)/I(MDK)	I(MDK) = 1...6 mA			-0.025		0.025	%/°C
111	Vf(MDK)	Voltage at MDK	Vf() = V(VCCA) - V(MDK), I(MDK) = 1 μA...6 mA			0.4		2	V
Laser Driver LDA									
201	Vs(LDA)	Saturation Voltage at LDA referenced to VCC	Vs(LDA) = V(VCC) - V(LDA); I(LDA) = -40 mA I(LDA) = -350 mA					1.0 1.5	V V
202	dI(MDA)	Load Balancing Error	I(LDA): -20 → -350 mA			-5		4	%
203	Ih(LDA)	Overcurrent Threshold in LDA				-700		-360	mA
204	toff()	Overcurrent Reset Delay	lack of feedback: I(MD) = 0 to I(LDA) > -10 mA, VCC = 5 V, CI = 1 μF					600	μs
205	Vf()	Flyback Diode Forward Voltage V(GND)-V(LDA)	I(LDA) > -350 mA					1.5	V
206	Rvcc()	Transient Protection Resistor	VCC to VCCA					3	Ω
207	Vt(MDA)	Shutdown Threshold at MDA	t > 1 μs			0.7		1.8	V

ELECTRICAL CHARACTERISTICS

Operating Conditions: VCC = 3.6...15 V, RM = 40 Ω...100 kΩ, Tj = -40...125 °C unless otherwise noted

Item No.	Symbol	Parameter	Conditions	Tj °C	Fig.				Unit
						Min.	Typ.	Max.	
Control Release Flip-Flop									
301	VCCen	Set Threshold for Enable Flip-Flop				0.6		1.9	V
302	Toff	Overtemperature Shutdown				140		165	°C

SAFETY INSTRUCTIONS

Laser light can damage the human eye and the eyes of animals! Do not look at any laser light directly or through any optical lens. When handling a laser diode, do not look directly at the light generated by it. Wear appropriate safety glasses to prevent light from entering the eye even by reflection.



FUNCTION DESCRIPTION

Setting the output power

The output power is simply set by $RM = V(MDA) / I(MD)$; with $V(MDA) = \text{Item-No. 101}$ and $I(MD) = \text{monitor current of the laser diode at the desired operating point}$. RM should be combined from fixed resistor (max. output power) and a trimmer (calibration).

Turn-on behaviour

After switching the supply voltage on, the output stage remains disabled until the internal enabling flip-flop is set by a sufficiently high voltage at VCC .

A quick soft start follows; the transition to controlled CW operation is gradual and primarily determined by the values of CI and RM . CI is properly dimensioned when the voltage overshoot at MDA is at a minimum.

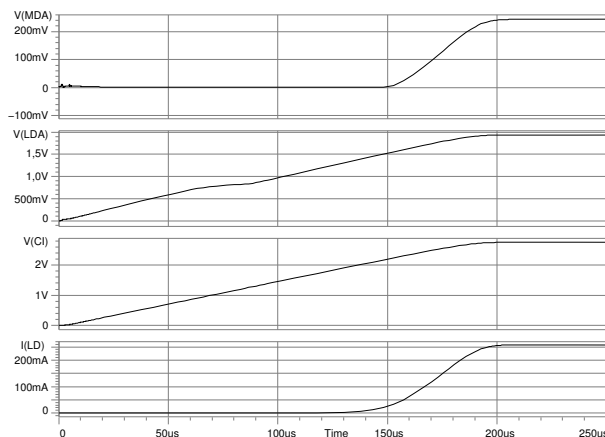

Figure 1: Turn-on behaviour

Turn-off behaviour

iC-WKM works without a fixed undervoltage lockout, thus the laser diode forward voltage is the prime factor determining the lowest possible supply voltage.

If the voltage drops below this value, the output stage is forcibly saturated and the laser current decreases. iC-WKM simultaneously discharges the control capacitor CI so that no excessive laser diode currents occur when the supply voltage rises again.

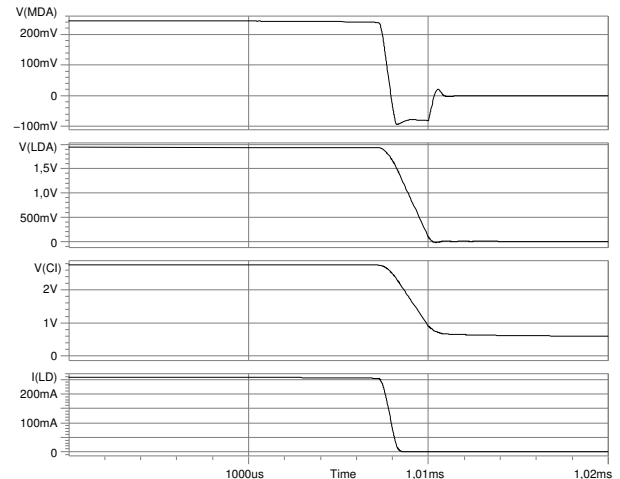

Figure 2: Turn-off behaviour

Disruptions in operation

The power control is shut down with excessive driver temperature or when the laser current reaches the overcurrent shutdown threshold, for example when the feedback is interrupted. If the monitor diode or the bias resistor RM fail, the device is shut down in less than $600 \mu s$, provided that the supply voltage applied is high enough.

When modulating the laser current via pin MDK , excessive voltage occurring at pin MDA also may cause a shutdown.

APPLICATION NOTES

Laser diode types

In principle, all three laser diode types can be operated by iC-WKM.

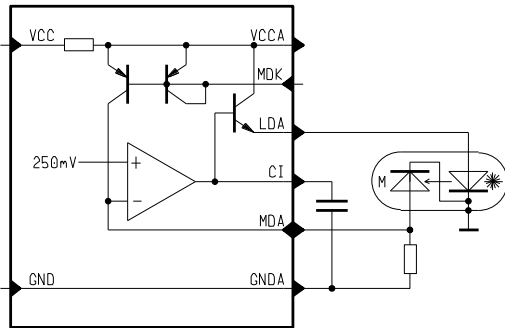

Figure 3: Operation of an **M-type** laser diode

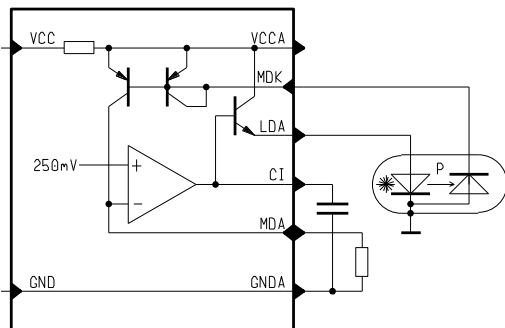

Figure 4: Operation of a **P-type** laser diode

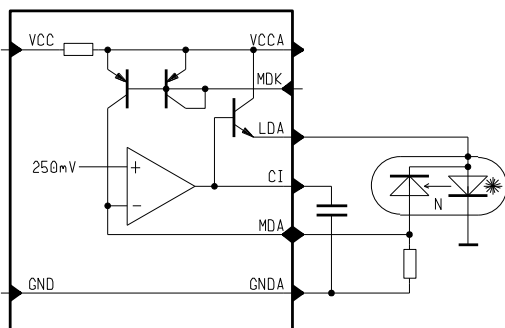

Figure 5: Operation of an **N-type** laser diode

As iC-WKM has been optimised for use with **M-type** laser diodes, it is with this type of diode that the best functionality is achieved. This type of setup also enables the laser diode package to be connected to GND.

With **P-type** laser diodes it is also possible to connect the laser diode package to GND. Here, however, the current mirror at MDK introduces a certain error to the automatic power control (c.f. Electrical Characteristics Nos. 108-110).

Even **N-type** laser diodes can be operated by iC-WKM; **iC-WKN**, however, which has been optimised for use with these diodes, may be a better choice.

Layout

To prevent instability of the regulator an additional capacitor (ca. 100 pF) must be positioned directly at the iC's pin CI. Depending on the laser diode, capacitor CM with typ. 2 nF in parallel to RM may be required for stability.

Pin AGND acts solely as a ground reference for the power regulator (CI and RM) and should not be short-circuited with GND externally. This could have a negative effect on the control behavior and monitor functions.

Cooling

Laser diodes should be sufficiently cooled, particularly with the power-regulated operation of setups which use iC-WKM, for example. The power dissipation in the laser diode otherwise causes the diode to heat up and the level of efficiency to drop which the power control unit then compensates for by increasing the laser current. This in turn brings about a rise in power dissipation in the laser diode and thus also in temperature. In this instance the laser diode could be damaged (resulting in spottiness and an increase in operating current) or even destroyed before the overcurrent shutdown threshold in iC-WKM is reached. This applies in particular to blue laser diodes whose power dissipation is considerably higher than that of red laser diodes, for example, due to the higher forward voltage.

This specification is for a newly developed product. iC-Haus therefore reserves the right to change or update, without notice, any information contained herein, design and specification; and to discontinue or limit production or distribution of any product versions. Please contact iC-Haus to ascertain the current data. Copying – even as an excerpt – is only permitted with iC-Haus approval in writing and precise reference to source.

iC-Haus does not warrant the accuracy, completeness or timeliness of the specification on this site and does not assume liability for any errors or omissions in the materials. The data specified is intended solely for the purpose of product description. No representations or warranties, either express or implied, of merchantability, fitness for a particular purpose or of any other nature are made hereunder with respect to information/specification or the products to which information refers and no guarantee with respect to compliance to the intended use is given. In particular, this also applies to the stated possible applications or areas of applications of the product.

iC-Haus conveys no patent, copyright, mask work right or other trade mark right to this product. iC-Haus assumes no liability for any patent and/or other trade mark rights of a third party resulting from processing or handling of the product and/or any other use of the product.

iC-WKM

M-TYPE CW LASER DIODE DRIVER

preliminary



Rev C1, Page 9/9

ORDERING INFORMATION

Type	Package	Order Designation
iC-WKM	SO8tp DFN10 4 mm x 4 mm	iC-WKM SO8 iC-WKM DFN10
Evaluation Board		iC-WKM EVAL WKM1D

For information about prices, terms of delivery, other packaging options etc. please contact:

iC-Haus GmbH
Am Kuemmerling 18
D-55294 Bodenheim
GERMANY

Tel.: +49 (61 35) 92 92-0
Fax: +49 (61 35) 92 92-192
Web: <http://www.ichaus.com>
E-Mail: sales@ichaus.com

X-ON Electronics

Largest Supplier of Electrical and Electronic Components

Click to view similar products for [laser components manufacturer](#):

Other Similar products are found below :

[FP-HD-L-635-7-30-F](#) [IG22X1000S4I](#) [FP-D-520-1-C-F](#) [FP-D-650-1D-C-F](#) [FP-LR-635-1-C-F](#) [FP-MV18-ST-660-20-30-F-STD](#) [FP-D-405-16-E-F](#) [FP-D-635-17-C-F](#) [FP-D-635-3-E-F](#) [FP-D-635-7-E-F](#) [FP-D-650-25-E-F](#) [FP-D-650-3-E-F](#) [FP-D-660-40-C-F](#) [FP-D-670-1-C-F](#) [FP-D-670-5-C-F](#) [FP-D-785-50-C-F](#) [FP-D-850-1-C-F](#) [FP-D-850-5-E-F](#) [FP-L-635-5-50-C](#) [FP-L-850-3-50-C](#) [FP-L-905-5-50-C](#) [FP-MG-19](#) [FP-MS-11.5](#) [FP-D-650-1-C-F](#) [IG17X1300S4I](#) [LC-LMD-635-03-03-A](#) [LC-LMD-650-05-01-A](#) [FP-MINI-635-1-F](#) [FP-MINI-650-1-F](#) [IG22X250S4I](#) [ILM12F-DOE-520-7-259-F](#) [FP-D-635-13-E-F](#) [FP-D-635-40-C-F](#) [FP-D-905-7-E-F](#) [FP-L-405-15-50-C](#) [FP-L-635-1-50-C](#) [FP-L-650-1-50-C](#) [LC-LMP-635-287-03-A](#) [FP-D-520-5-C-F](#) [IG17X250S4I](#) [ILM12F-DOE-635-7-247-F](#) [FP-D-635-1-C-F](#) [FP-D-635-1-C-F-24V](#) [ILM12F-D-520-1-C-F](#) [FP-D-650-20-C-F-24](#) [ADL-65104TA4](#) [ILM12F-L-520-7-58-F](#) [ADL-65104TL](#) [LC-LMD-635-02-03-A](#) [FP-HD-DOE-520-7-289-F](#)