

**Proven
Reliability**

AG SERIES

ISOLATED, PROPORTIONAL DC TO HV DC CONVERTERS

100V to 6000V @ 1.0 and 1.5 Watts

**Extremely Low Profile: 0.128 inches
and volume of < 0.100 cubic inches⁵**

**NOW
UL RECOGNIZED**

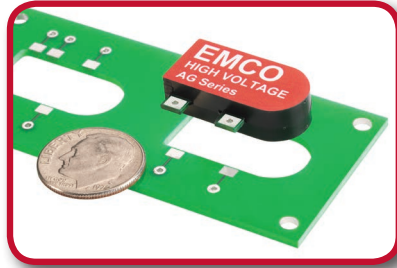

PRODUCT DESCRIPTION

The AG Series is a new line of ultra-miniature DC to HV DC converters that set an industry standard in high voltage miniaturization. These component-sized converters are ideal for applications requiring minimal size and weight. Occupying less than one tenth of a cubic inch of volume⁵, this unique package features an extremely low profile of only 0.128 inches (3.25mm) when mounted in from the top, or 0.152 (3.86mm) when mounted in from the bottom of the PCB! The AG Series converter can also mount off the PCB with .030" diameter pins. See page 9 for illustrations. Controllable output voltages range from 100 volts to 6000 volts. Please refer to the A Series data sheet for PCB pin mounting.

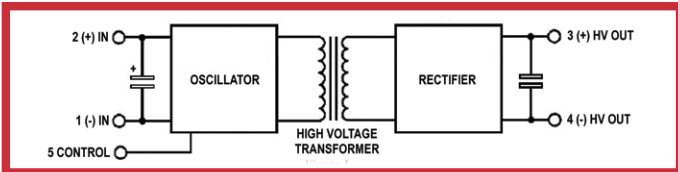

APPLICATIONS

- Avalanche Photodiodes
- Capacitor Charging
- Electrophoresis
- Photomultiplier Tubes
- Piezo Devices
- Mass Spectrometry
- Sustaining Ion Pumps

OPTIONS

- 1 Watt and 1.5 Watt Versions Available (AG/AGH)
- Available in 3 Standard Input Voltage Ranges: 0 to 5, 12 or 24VDC (up to 3 kV)
- Polarity: Choose Positive or Negative Output (P/N)
- Extended Operating Temperature (AG Models / 1.0W) (T Suffix)
- Alternate Input / Output Voltages (Consult Factory)
- See Ordering Information (Page 12)

PRODUCT SELECTION TABLE

VDC	STANDARD 1 WATT - AG MODEL		1.5 WATT OPTION - AGH MODEL	
	MODEL	MAXIMUM OUTPUT CURRENT*1	MODEL	MAXIMUM OUTPUT CURRENT*1
100 VDC	AG01	10 mA	AGH01 ⁷	15 mA
200 VDC	AG02	5 mA	AGH02	7.5 mA
250 VDC	AG025	4 mA	AGH025	6 mA
300 VDC	AG03	3.33 mA	AGH03	5mA
400 VDC	AG04	2.5 mA	AGH04	3.75 mA
500 VDC	AG05	2 mA	AGH05	3 mA
600 VDC	AG06	1.67 mA	AGH06	2.5 mA
700 VDC	AG07	1.43 mA	AGH07	2.15 mA
800 VDC	AG08	1.25 mA	AGH08	1.87 mA
900 VDC	AG09	1.1 mA	AGH09	1.67 mA
1000 VDC	AG10	1 mA	AGH10	1.5 mA
1200 VDC	AG12	0.83 mA	AGH12	1.25 mA
1500 VDC	AG15	0.66 mA	AGH15	1 mA
2000 VDC	AG20	0.5 mA	AGH20	0.75 mA
3000 VDC	AG30	0.32 mA	AGH30	0.5 mA
4000 VDC	AG40	0.24 mA	-	-
5000 VDC	AG50	0.2 mA	-	-
6000 VDC	AG60	0.167 mA	AGH60	0.25 mA

Complete List of Models on page 2

FEATURES

- Proportional Input/Output
- Low Noise Quasi-sinewave Oscillator
- Control Pin (can be used for on/off control)
- Low Leakage Current
- Low Input/Output Capacitance
- Input to Output Galvanic Isolation
- Short Circuit Protection, 1 Minute Minimum
- No Minimum Load Required²
- MTBF > 1,862,000 hours, per Bellcore TR 332
- Surface Mount Package
- UL 94V-0 Listed Proprietary Encapsulant
- No external components required
- RoHS Compliant

ISO 9001:2008
CERTIFIED

ISO 14001:2004
CERTIFIED

RoHS
COMPLIANT

UL
E344664

CE

IPC
Certified J-STD-001
Application Specialist

ELECTRICAL SPECIFICATIONS*3

OUTPUT VOLTAGE*2 (To select polarity, see pg. 12 - How to Order)	STANDARD 1 WATT - AG MODEL			1.5 WATT OPTION - AGH MODEL		
	MODEL	MAXIMUM OUTPUT CURRENT*1	RIPPLE P-P*4	MODEL	MAXIMUM OUTPUT CURRENT*1	RIPPLE P-P*4
0 to 100 VDC	AG01	10 mA	5%	AGH01 *7	15 mA	4%
0 to 200 VDC	AG02	5 mA	1%	AGH02	7.5 mA	3%
0 to 250 VDC	AG025	4 mA	.90%	AGH025	6 mA	1.2%
0 to 300 VDC	AG03	3.33 mA	.70%	AGH03	5 mA	.70%
0 to 400 VDC	AG04	2.5mA	.50%	AGH04	3.75 mA	.75%
0 to 500 VDC	AG05	2 mA	.50%	AGH05	3 mA	.70%
0 to 600 VDC	AG06	1.67 mA	1%	AGH06	2.5 mA	2%
0 to 700 VDC	AG07	1.43 mA	.50%	AGH07	2.15 mA	1.2%
0 to 800 VDC	AG08	1.25 mA	1%	AGH08	1.87 mA	1.2%
0 to 900 VDC	AG09	1.1 mA	1%	AGH09	1.67 mA	1.2%
0 to 1000 VDC	AG10	1 mA	.79%	AGH10	1.5 mA	1%
0 to 1200 VDC	AG12	0.83 mA	.50%	AGH12	1.25 mA	.60%
0 to 1500 VDC	AG15	0.67 mA	.40%	AGH15	1 mA	.60%
0 to 2000 VDC	AG20	0.5 mA	.30%	AGH20	0.75 mA	.50%
0 to 3000 VDC	AG30	0.33 mA	.20%	AGH30	0.5 mA	.20%
0 to 4000 VDC	AG40	0.25 mA	.12%	-	-	-
0 to 5000 VDC	AG50	0.2 mA	.15%	-	-	-
0 to 6000 VDC	AG60	0.167 mA	.15%	AGH60	0.25 mA	.25%

	INPUT CURRENT			
	AG MODELS - 1 Watt		AGH MODELS - 1.5 Watt	
VIN	NO-LOAD	FULL-LOAD	NO-LOAD	FULL-LOAD
5 VDC	<200mA	<470mA	<300mA	<550mA
12 VDC	<100mA	<185mA	<125mA	<250mA
24 VDC	<25mA	<60mA	<40mA	<120mA

ELECTRICAL SPECIFICATIONS*3

PARAMETER	VALUE
INPUT VOLTAGE	0 TO 5, 12, OR 24V (FOR MODELS UP TO 3KV)
	0 TO 5V (FOR MODELS OVER 3KV)
TURN-ON VOLTAGE	<0.7 VDC
ISOLATION	< +/- 500V BIAS ON PIN 4
OUTPUT VOLTAGE TOLERANCE	+10%, -10% FULL LOAD, MAX. INPUT VOLTAGE
INPUT/OUTPUT COUPLING CAPACITANCE	<250 pf TYPICAL
INPUT/OUTPUT LEAKAGE CURRENT	<50 nA TYPICAL
CONTROL PIN	0 TO MAX INPUT VOLTAGE
INTERNAL OSCILLATOR FREQUENCY	50kHz - 350kHz
STANDARD TEMPERATURE RANGES	OPERATING: -25° TO +75°C*6 (CASE)
	STORAGE: -55° TO +105°C
EXTENDED TEMPERATURE RANGES (-T OPTION)	OPERATING: -55° TO +85°C*6 (CASE) (AG Models/1.0W)
	STORAGE: -55° TO +105°C

DETAILED PRODUCT DESCRIPTION

The AG Series is a new line of ultra-miniature, DC to HV DC converters that set an industry standard in high voltage miniaturization. These component-sized converters are ideal for applications requiring minimal size and weight. Occupying less than one tenth of a cubic inch of volume⁵, this unique package features an extremely low profile of only 0.128 inches (3.25mm) when mounted in from the top, or 0.152 (3.86mm) when mounted in from the bottom of the PCB! The AG Series converter can also mount off the PCB with .030" diameter pins. See page 9 for illustrations. Controllable output voltages range from 100 volts to 6000 volts.

Turn-on voltage is very low at less than 0.7 volts, allowing for wide output voltage operating range. Use of a resonant, quasi-sinewave oscillator and fully shielded transformer result in clean, reliable high voltage conversion with inherently low ripple, EMI/RFI and input ripple current, making this product ideal for integration into noise sensitive equipment.

A separate high impedance control pin is standard and is designed for external error amplifier and/or DAC control in closed or open loop systems, or simply connect the control pin to the + input for proportional input to output operation (see performance charts below).

Output power is 1 watt standard, with 1.5 watts available as an option. No minimum load is required. A proprietary vacuum encapsulation process and custom 94V-0 listed, high performance formula are used to achieve excellent high voltage and thermal properties. Isolation is +/- 500V bias on the output return. Input to output leakage current is very low at less than 100 nA and coupling capacitance is also low at <250 pF.

The AG Series leverages XP-EMCO's Best-in-Class long-term reliability, utilizing proven DC to high voltage DC conversion technology, perfected by over four decades of high voltage design experience in the most demanding applications. Our extensive in-house capabilities enable us to meet specific customer requirements with standard, modified and custom solutions quickly, easily, and economically. Technical assistance is readily available.

Small quantities are readily available. For large quantities, please consult our sales office or stocking distributor in Switzerland, Condatas AG.

MECHANICAL SPECIFICATIONS (100V - 2,000V)

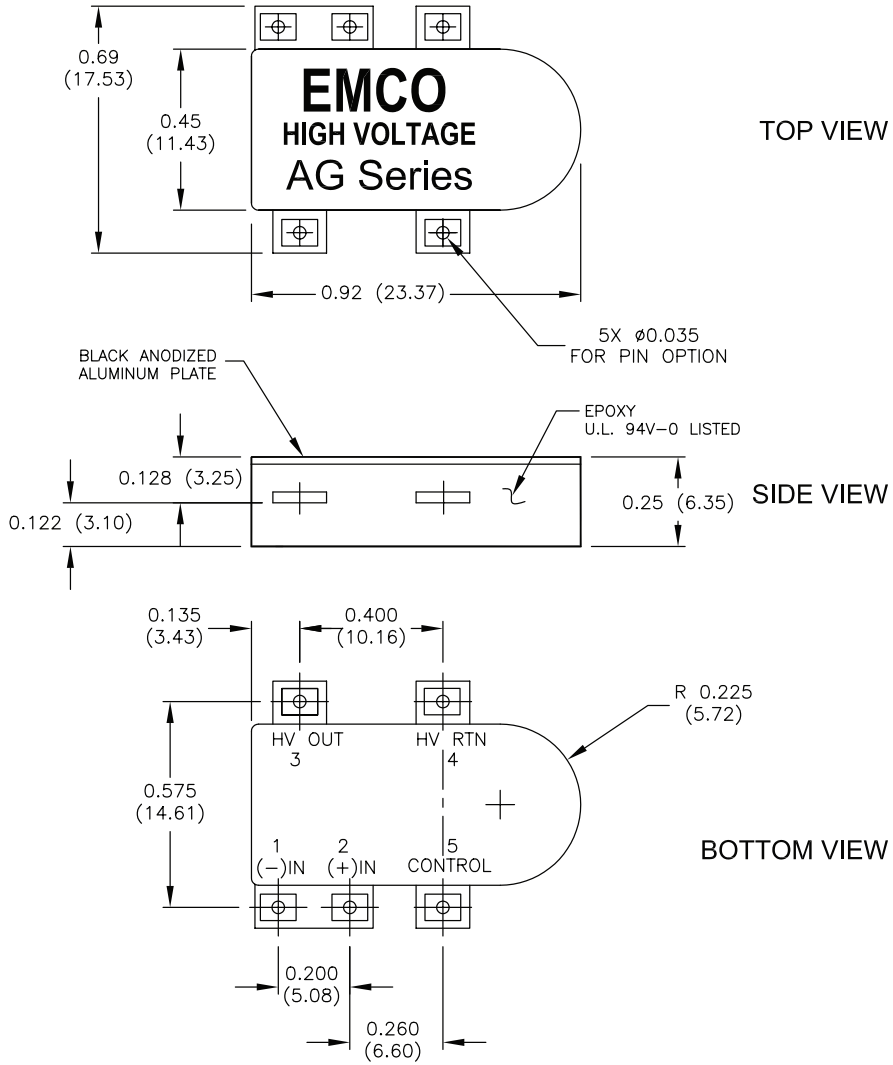

DIMENSIONS ARE IN INCHES (METRIC EQUIVALENTS ARE IN PARENTHESIS)
DIMENSIONAL TOLERANCES: .XX = \pm 0.02 (0.51), .XXX = \pm 0.005 (0.127)

PARAMETER	VALUE
WEIGHT	< 0.20 OZ. (5.66 GRAMS)
VOLUME	< 0.10 CUBIC INCHES (1.639 CUBIC CENTIMETERS)
BODY DIMENSIONS	0.92L (23.37L) x 0.45W (11.43W) x 0.25H (6.35H)
BODY + WING DIMENSIONS	0.92L (23.37L) x 0.69W (17.53W) x 0.25H (6.35H)

PIN #	FUNCTION
1	(-) INPUT
2	(+) INPUT
3	HV OUT
4	HV RTN
5	CONTROL

MECHANICAL SPECIFICATIONS (3,000V – 5,000V)

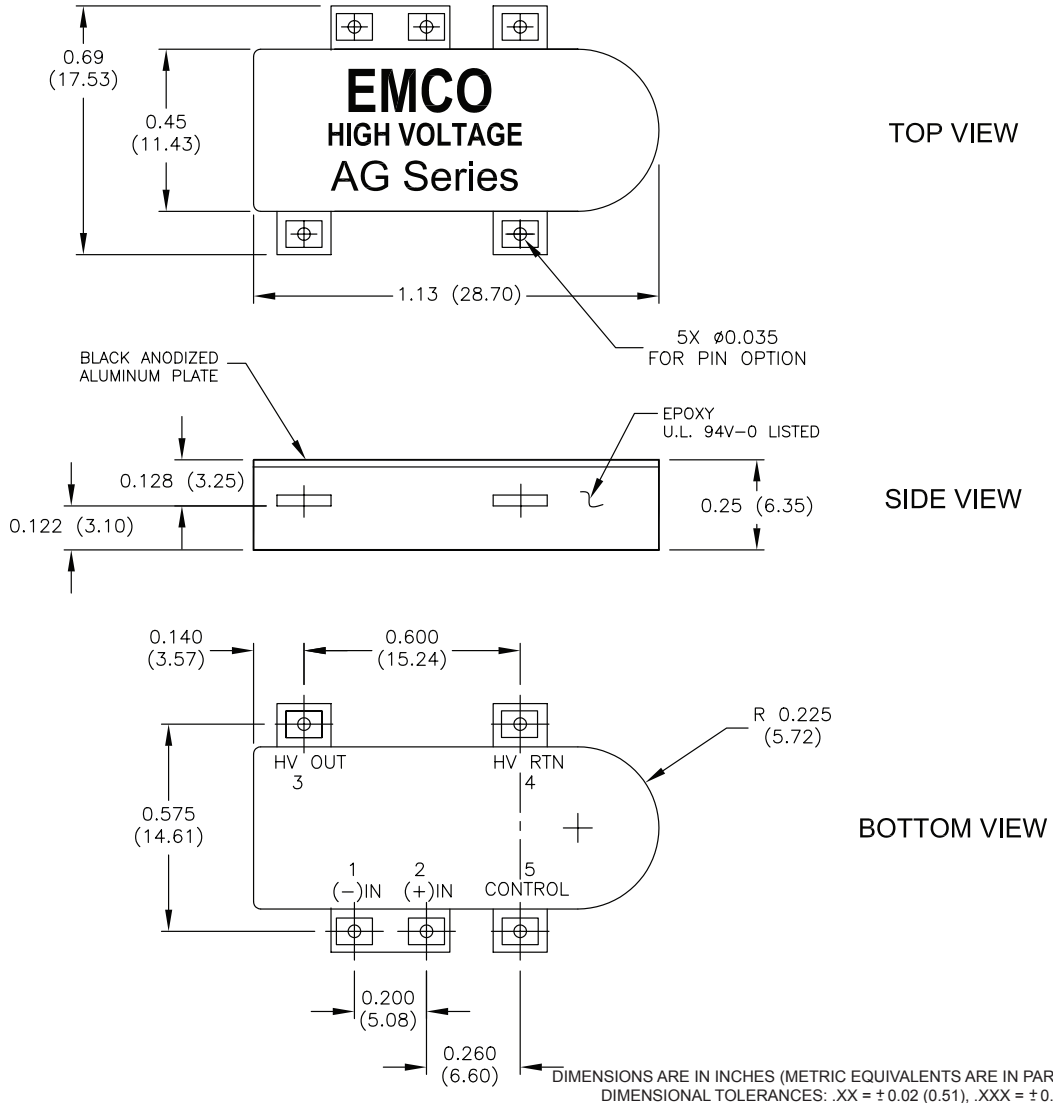

PARAMETER	VALUE
WEIGHT	< 0.20 OZ. (5.66 GRAMS)
VOLUME	<0.125 CUBIC INCHES (2.048 CUBIC CENTIMETERS)
BODY DIMENSIONS	1.13L (28.70L) x 0.45W (11.43W) x 0.25H (6.35H)
BODY + WING DIMENSIONS	1.13L (28.70L) x 0.69W (17.53W) x 0.25H (6.35H)

PIN #	FUNCTION
1	(-) INPUT
2	(+) INPUT
3	HV OUT
4	HV RTN
5	CONTROL

MECHANICAL SPECIFICATIONS (6,000V)

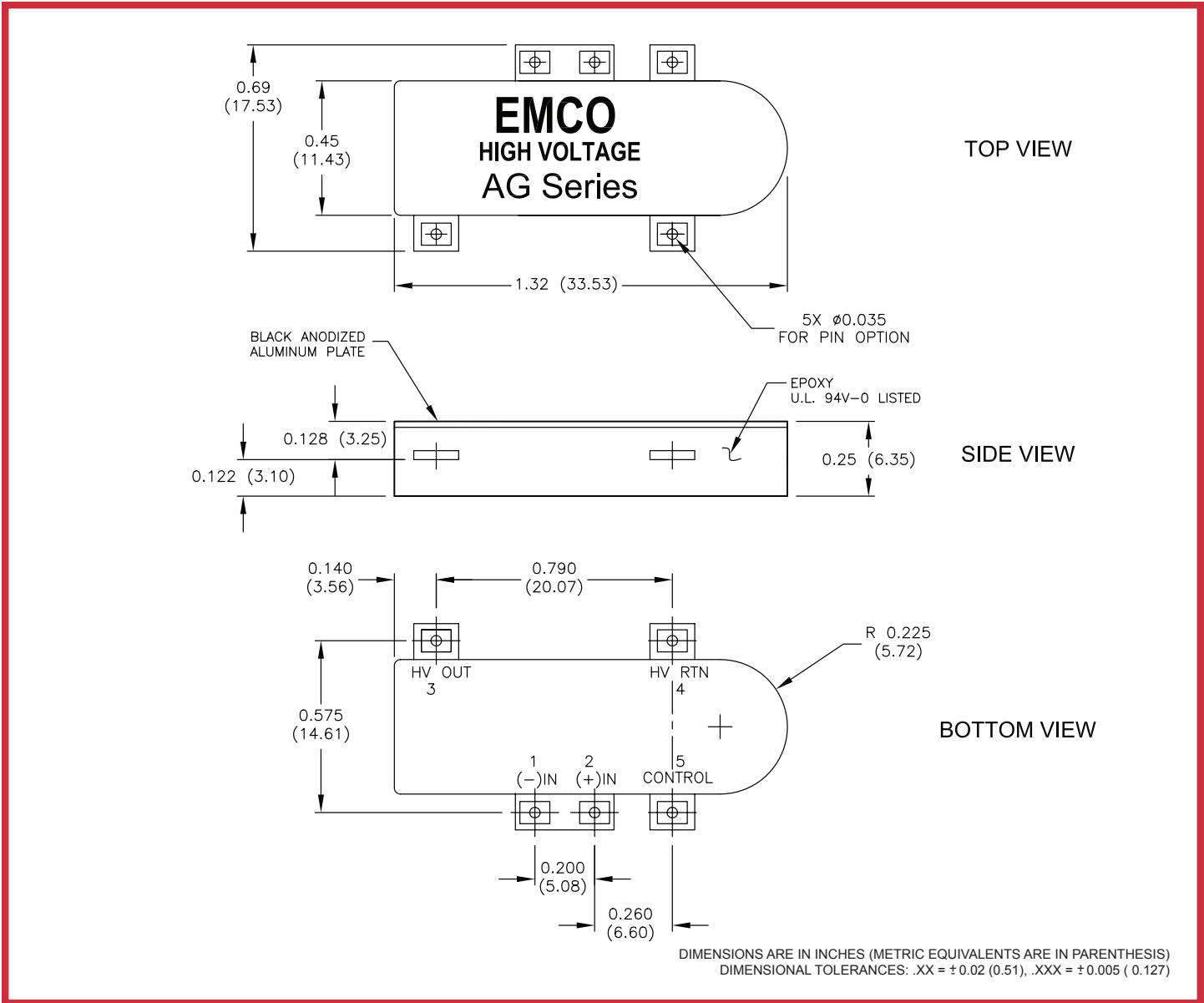

PARAMETER	VALUE
WEIGHT	< 0.20 OZ. (5.66 GRAMS)
VOLUME	<0.156 CUBIC INCHES (2.556 CUBIC CENTIMETERS)
BODY DIMENSIONS	1.32L (33.53L) x 0.45W (11.43W) x 0.25H (6.35H)
BODY + WING DIMENSIONS	1.32L (33.53L) x 0.69W (17.53W) x 0.25H (6.35H)

PIN #	FUNCTION
1	(-) INPUT
2	(+) INPUT
3	HV OUT
4	HV RTN
5	CONTROL

MECHANICAL SPECIFICATIONS

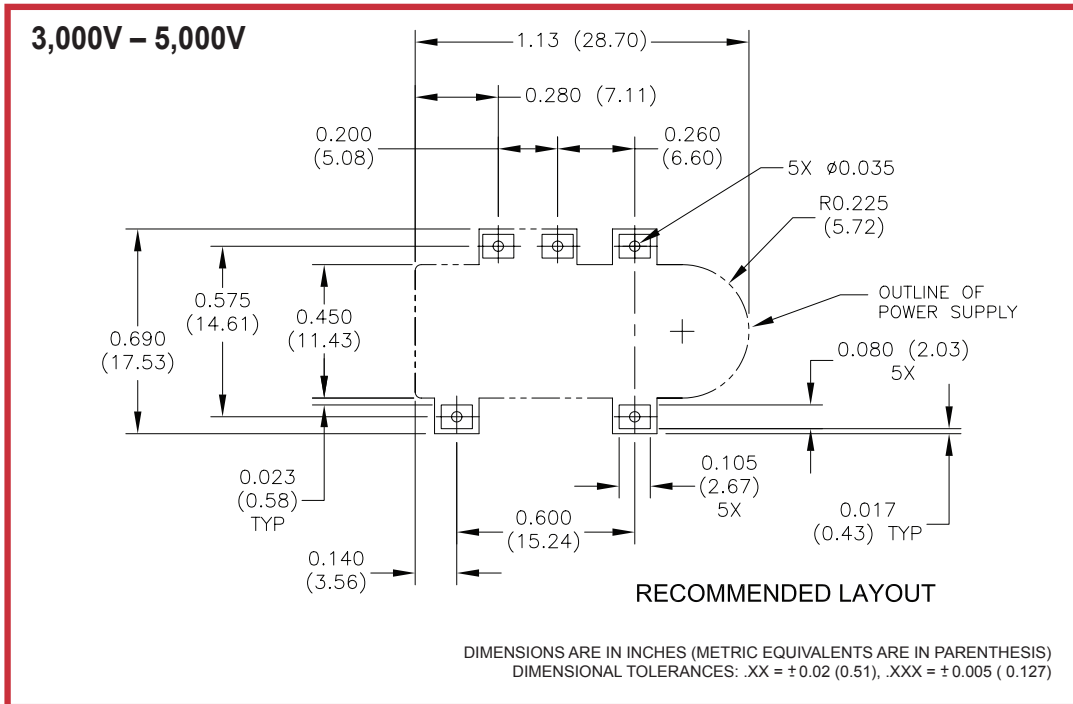
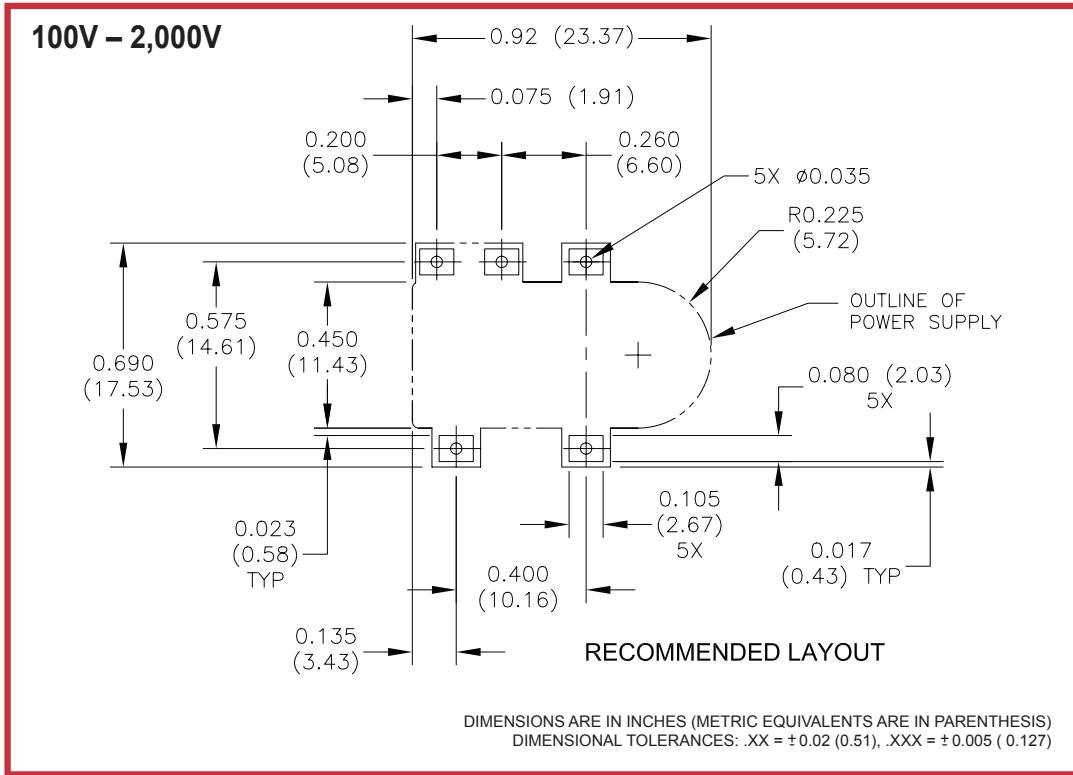

MECHANICAL SPECIFICATIONS

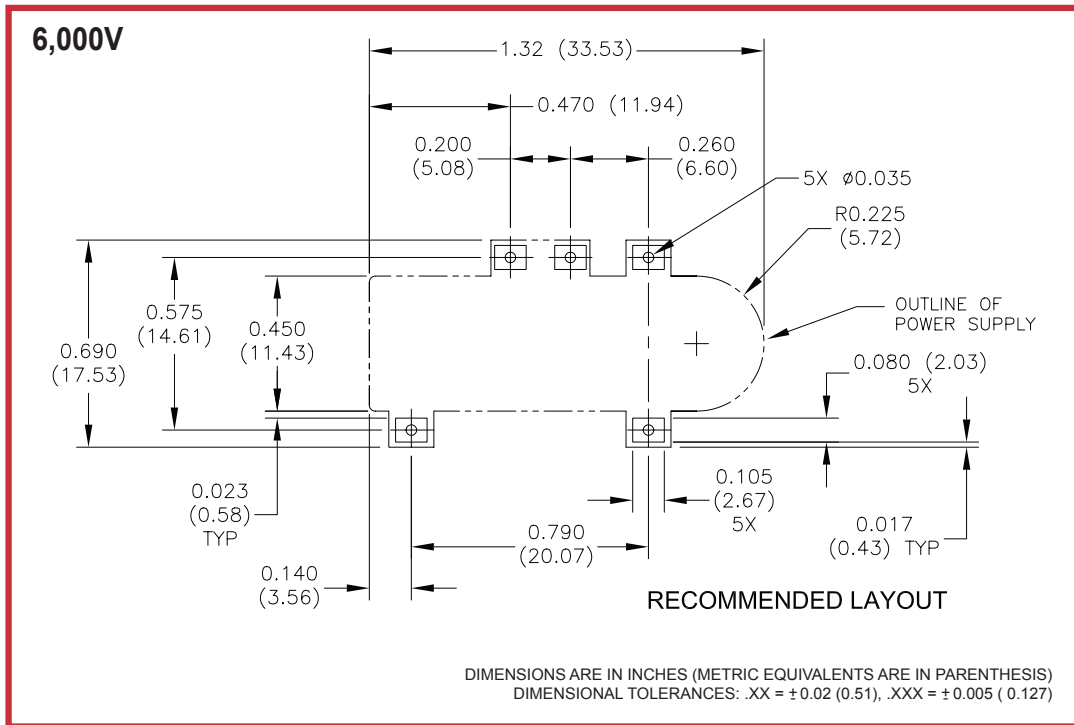

AG INSTALLATION

AG Mounted
on Top of PCB



AG Mounted
From Bottom
of PCB

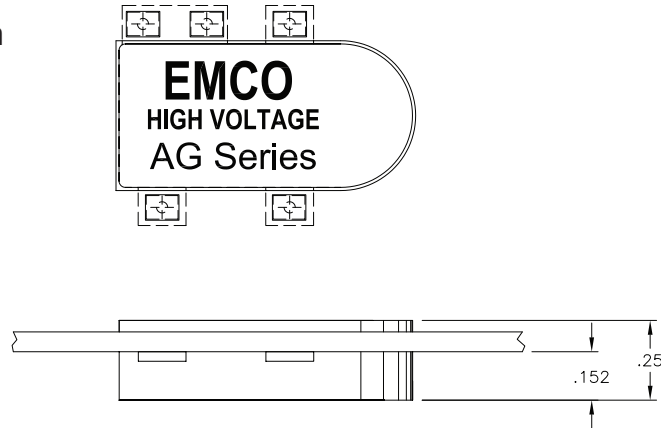

AG Mounted Off
PCB With .030"
DIA Pins

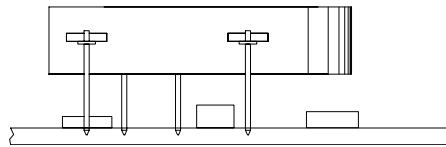

*Height of pin can vary depending upon application

AG RoHS REFLOW PROFILE

Probe	Reflow Results						
	Positive Slope (°C/sec)	Positive Slope Time (mm:ss.tt)	Rise Time (120.0 - 180.0°C) (mm:ss.tt)	Mean Slope to Peak (°C/sec)	Time Above Liquidus (217.0°C) (mm:ss.tt)	Peak Temperature (°C)	Negative Slope (°C/sec)
(°C) Module Lead Top	2.62	03:43.50	01:17.00	0.77	00:44.00	237.5	-2.59

Probe	Maximum / Minimum						
	Maximum (°C)	Max. Reached (mm:ss.tt)	Mean (°C)	Deviation from 255.0°C	Standard deviation	Minimum (°C)	Min. Reached (mm:ss.tt)
(°C) Module Lead Top	237.5	04:18.00	139.8	-17.5	56.5	38.5	00:00.00

Probe	Time at Temperature		Slopes	
	Time Above 230.0°C (mm:ss.tt)	Time to Reach 230.0°C (mm:ss.tt)	Positive Slope (°C/sec)	Mean Slope (°C/sec)
(°C) Module Lead Top	00:16.00	04:09.50	2.62	0.38

*Reflow profile is subject to change based on your application

APPLICATION NOTES

Typical HV Output vs. Control Voltage

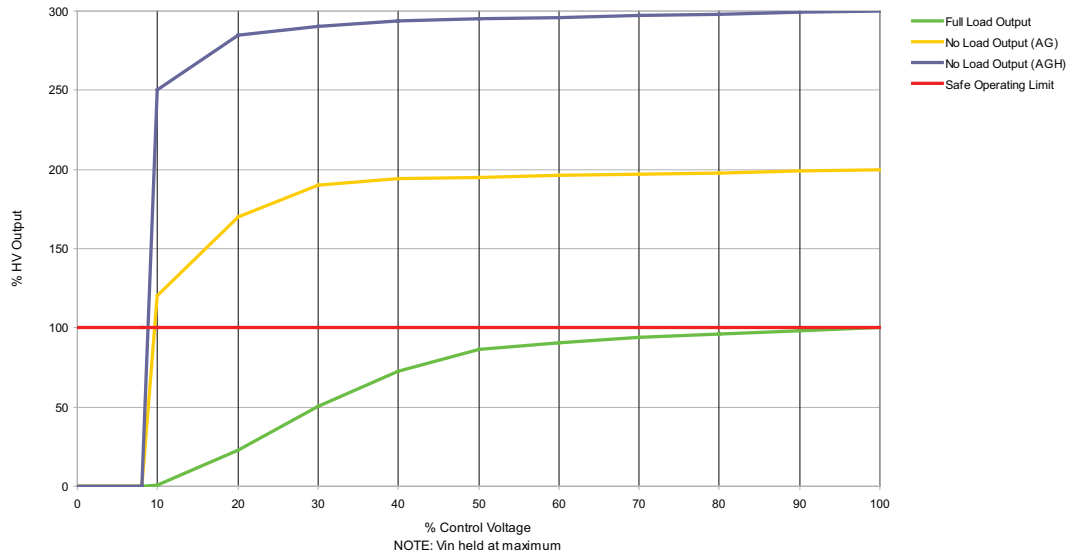

TYPICAL INPUT vs. OUTPUT VOLTAGE

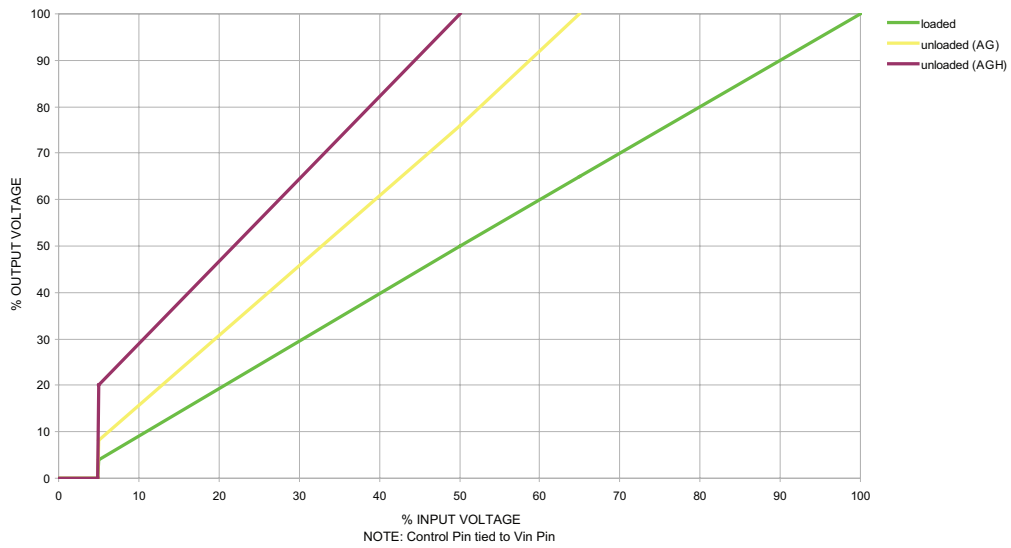

Output Voltage is load dependent. Under light or no-load conditions, reduce the Input Voltage so maximum rated Output Voltage is not exceeded.

OPTION CODES

ORDERING INFORMATION		ORDER CODE	AVAILABILITY
OUTPUT VOLTAGE	1 WATT	AG	ALL
	1.5 WATT	AGH	ALL
POLARITY DESIGNATOR	POSITIVE OUTPUT	P	ALL
	NEGATIVE OUTPUT	N	ALL
INPUT VOLTAGE	5 VDC	5	ALL/Except AGH01 Model
	12 VDC	12	UP TO 3KV
	24 VDC	24	UP TO 3KV
OPTIONS	EXTENDED TEMP	T	AG MODELS/1W

HOW TO ORDER

PART NUMBER SELECTOR:

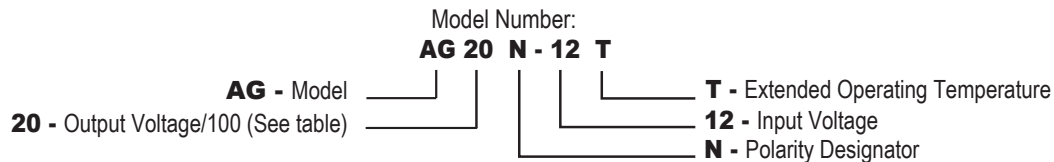

EXAMPLE: **AG20N-12T** (**AG** - Model, **20** - Output Voltage, **N** - Negative, **12** - Input Voltage, **T** - Extended Operating Temperature)

- *Note:
1. At maximum rated output voltage.
 2. Output Voltage is load dependent. Under light or no-load conditions, reduce the Input Voltage so maximum rated Output Voltage is not exceeded.
 3. Specifications after 30 minute warm-up, full-load, at 25°C, unless otherwise noted.
 4. Ripple may be reduced substantially by the addition of an external RC filter.
 5. Volume will vary depending on package size.
 6. Proper thermal management techniques are required to maintain safe case temperature at maximum power output.
 7. The AGH01 is only available in 12V or 24V.

XP-EMCO reserves the right to make changes on products and literature, including specifications, without notice. XP-EMCO standard product models are not recommended for "copy-exact" applications or any other application restricting product changes. "Copy-exact" options are available. Please contact an XP-EMCO sales representative for more details.

X-ON Electronics

Largest Supplier of Electrical and Electronic Components

Click to view similar products for [Isolated DC/DC Converters](#) category:

Click to view products by [XP Power](#) manufacturer:

Other Similar products are found below :

[ESM6D044440C05AAQ](#) [MI-220-IW](#) [MI-J22-IY](#) [MI-LC20-IW](#) [FMD15.24G](#) [PSL486-7LR](#) [Q48T30020-NBB0](#) [AVO240-48S12B-6L](#) [NAN-0505](#)
[HW-L16D](#) [JAHW100Y1](#) [22827](#) [LT1084CP](#) [SPB05C-12](#) [SQ24S15033-PS0S](#) [18952](#) [19-130041](#) [CE-1003](#) [CE-1004](#) [GQ2541-7R](#) [PSE1000DCDC-](#)
[12V](#) [RDS180245](#) [MAU228](#) [419-2065-201](#) [449-2075-101](#) [J80-0041NL](#) [V24B3V3C150BG](#) [V24C12M100BL](#) [V24C5C100BL2](#) [V300B28C250BF3](#)
[V300C12C150BG](#) [V300C24C150BG](#) [V375C24E150BG](#) [VE-JW3-CY](#) [VI-241-EU](#) [419-2063-401](#) [419-2067-501](#) [DCG40-5G](#) [DFC15U48D15](#) [XGS-](#)
[0512](#) [XGS-1205](#) [XGS-1212](#) [XGS-2412](#) [XGS-2415](#) [XKS-1215](#) [033456](#) [NCT1000N040R050B](#) [SPB05B-15](#) [SPB05C-15](#) [SSQE48T25025-NAA0G](#)