

EC 20 flat $\varnothing 20$ mm, brushless, 5 Watt

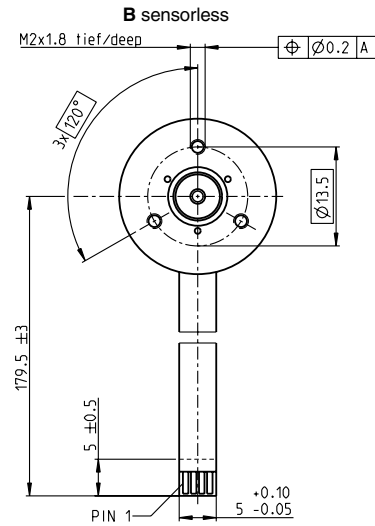
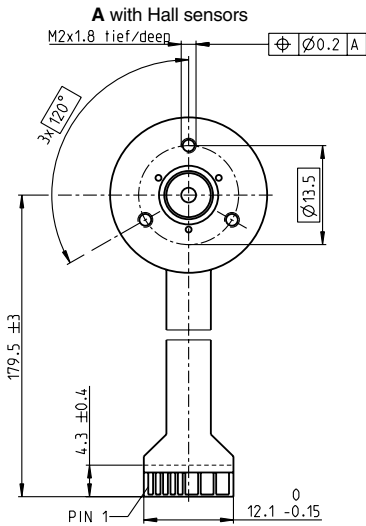
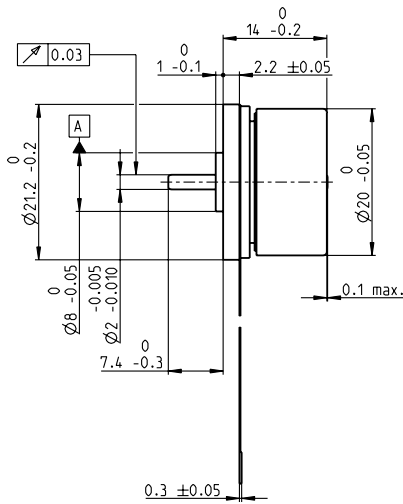

M 1:1

- Stock program
- Standard program
- Special program (on request)

Part Numbers

	351005	351006	351007	351008
A with Hall sensors				
B sensorless	351054	351055	351056	351057

Motor Data (provisional)

Values at nominal voltage

	V	6	9	12	24
1 Nominal voltage	V	6	9	12	24
2 No load speed	rpm	9350	9430	9380	9300
3 No load current	mA	102	68.3	51.1	25.1
4 Nominal speed	rpm	4970	5410	5210	5240
5 Nominal torque (max. continuous torque)	mNm	7.25	8.36	7.5	7.71
6 Nominal current (max. continuous current)	A	1.26	0.951	0.648	0.328
7 Stall torque	mNm	17.2	22.4	18.9	19.9
8 Starting current	A	2.93	2.54	1.61	0.838
9 Max. efficiency	%	67	71	68	69

Characteristics

	Ω	2.05	3.54	7.45	28.6
10 Terminal resistance phase to phase	Ω	2.05	3.54	7.45	28.6
11 Terminal inductance phase to phase	mH	0.189	0.424	0.754	3.09
12 Torque constant	mNm/A	5.88	8.82	11.8	23.8
13 Speed constant	rpm/V	1620	1080	812	402
14 Speed/torque gradient	rpm/mNm	567	435	515	484
15 Mechanical time constant	ms	30.3	23.2	27.5	25.8
16 Rotor inertia	gcm ²	5.1	5.1	5.1	5.1

Specifications

Thermal data

17 Thermal resistance housing-ambient	13.7 K/W
18 Thermal resistance winding-housing	2.66 K/W
19 Thermal time constant winding	1.77 s
20 Thermal time constant motor	22.8 s
21 Ambient temperature	-40...+100°
22 Max. permissible winding temperature	+125°C

Mechanical data (preloaded ball bearings)

23 Max. permissible speed	15000 rpm
24 Axial play at axial load < 2.0 N	0 mm
24 Axial play at axial load > 2.0 N	0.14 mm
25 Radial play	preloaded
26 Max. axial load (dynamic)	1.8 N
27 Max. force for press fits (static) (static, shaft supported)	26 N / 200 N
28 Max. radial loading, 5 mm from flange	10 N

Other specifications

29 Number of pole pairs	4
30 Number of phases	3
31 Weight of motor	22 g

Values listed in the table are nominal.

Connection	with Hall sensors	sensorless
Pin 1	V _{Hall} 4.5...24 VDC	Motor winding 1
Pin 2	Hall sensor 3	Motor winding 2
Pin 3	Hall sensor 1	Motor winding 3
Pin 4	Hall sensor 2	neutral point
Pin 5	GND	
Pin 6	Motor winding 3	
Pin 7	Motor winding 2	
Pin 8	Motor winding 1	

Adapter	Part number	Part number
see p. 339	220300	220300

Connector	Part number	Part number
Tyco	1-84953-1	84953-4
Molex	52207-1185	52207-0485
Molex	52089-1119	52089-0419

Pin for design with Hall sensors:
FPC, 11-pol, Pitch 1.0 mm, top contact style
Wiring diagram for Hall sensors see p. 31

Operating Range

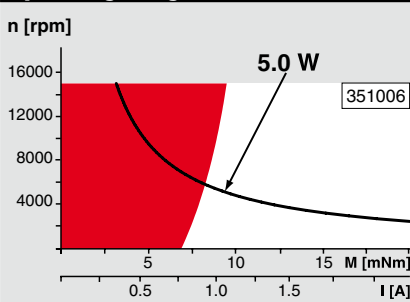

Comments

Continuous operation
In observation of above listed thermal resistance (lines 17 and 18) the maximum permissible winding temperature will be reached during continuous operation at 25°C ambient.
= Thermal limit.

Short term operation
The motor may be briefly overloaded (recurring).

Assigned power rating

maxon Modular System

Overview on page 20 - 25

Spur Gearhead

$\varnothing 20.3$ mm
0.06 - 0.25 Nm
Page 247

Planetary Gearhead

$\varnothing 22$ mm
0.5 - 2.0 Nm
Page 250/252

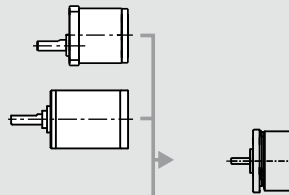

Recommended Electronics:

ESCON 36/3 EC	Page 320
ESCON 50/5, Module 50/5	321
DECS 50/5	324
DEC Module 24/2	325
EPOS2 24/2	330
EPOS3 70/10 EtherCAT	337
Notes	24

X-ON Electronics

Largest Supplier of Electrical and Electronic Components

Click to view similar products for [maxon](#) manufacturer:

Other Similar products are found below :

[110340](#) [250521](#) [203892](#) [110455](#) [403962](#) [440557](#) [403112](#) [137576](#) [118391](#) [110048](#) [251601](#) [403957](#) [367661](#) [240987](#) [242472](#) [110338](#)