

45Amp, 10.16 mm pitch, Board to Wire Connector for Internal Power Supply

DF60 Series

(UL, C-UL, TÜV certified product)

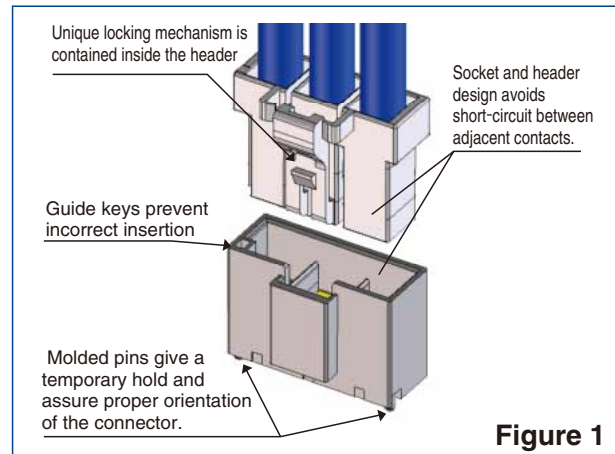

■ Features

1. High current capacity

Capable of going to a max. of 45A when using AWG #8 with the single position connector. (Please refer to the chart for the rated current in other pin counts.)

2. Secure lock mechanism ensures complete mating

A secure lock mechanism with a clear tactile and audible click prevents insufficient mating. (Please refer to Figure 2)

3. Highly reliable 5-point contact structure

Three independent contact springs provide a secure contact with high contact reliability using 5-point of contact. (Please refer to Figure 3))

4. Molded lance design

The lance is actually part of the housing instead of being part of the terminal. This prevents tangled wires during assembly.

5. Mis-insertion prevention for headers

The addition of a molded pin on the header allows temporary mounting retention and prevents reverse mounting on the PCB. (Please refer to Figure 1). (Right angle pin header has a metal fitting for this purpose)

6. Prevention of solder cracks

Glass-reinforced resin is used on pin header to prevent solder cracks due to thermal contraction.

7. Design Prevents short-circuits between contacts

The wall structure between contacts isolates the contacts and prevents short circuits from occurring. (Please refer to Figure 1)

8. Compliant to UL, C-UL and TÜV specifications

● Lock structure

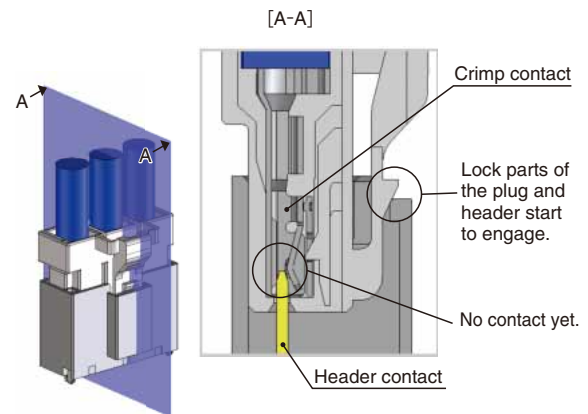
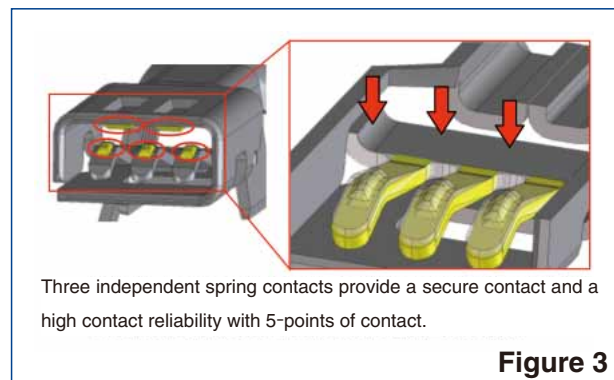

Figure 2



Product Specifications

Ratings	Current Rating (Note 1)	No. of Contacts	AWG#8	AWG#10	AWG#12	Operating Temperature -55~105°C (Note 2)
		1	45A	38A	30A	Operating Humidity Range 20~80%
		2	40A	31A	26A	Storage Temperature Range -10~60°C (Note 3)
		3	40A	31A	26A	Storage Humidity Range 40~70% (Note 3)
		4	38A	30A	25A	UL/TÜV file No. and certification No. UL : E52653 C-UL : E52653 TÜV : R50244085
		5	38A	30A	25A	
	6	38A	30A	25A		
	Specifications		AC/DC	1,000V		
	Voltage Rating	UL/C-UL		AC/DC	600V	
		TÜV		AC/DC	600V	

Item	Specifications	Conditions
1. Insulation resistance	No less than 1,000 MΩ	Measured at DC=1,000V
2. Withstand voltage	No flashover or breakdown	AC 3,000V applied for one minute.
3. Contact resistance	No more than 2 mΩ	Measured at 1A and not greater than 6V
4. Vibration Resistance	No electrical discontinuity of 1μs or greater	Frequency 10 - 500Hz, accelerated velocity 98 m/s ² , 2 hours for each of the three axis directions
5. Shock Resistance	No electrical discontinuity of 1μs or greater	Accelerated velocity: 490m/s ² , for 11 ms, half-sine wave form in 3 directions, 3 times for each of the three directions
6. Moisture-resistance	Contact resistance: no more than 2 mΩ; insulation resistance: no less than 1,000 MΩ	Temperature: 40±2°C; humidity: 90 to 95%, left for 96 hours
7. Temperature cycles	Contact resistance: no more than 2 mΩ; insulation resistance: no less than 1,000 MΩ	-55°C: 30 minutes → 85°C: 30 minutes) 25 cycles
8. Durability	Contact resistance No more than 2 mΩ	30 mating/unmating cycles
9. Solder heat resistance	There should be no melting of the resin part which will influence the performance.	Flow: 260°C, 10sec Hand soldering: temperature of soldering iron at 350°C±10°C for 5 seconds

(Note 1) This is the maximum current rating while all pins are powered or used as all power lines. If you split the current over multiple lines, please factor in your own safety margin.

(Note 2) Includes the temperature rise of power lines.

(Note 3) The storage condition refers to long-term storage of the product on the shelf before assembly. Please use the operating temperature for temporary storage such as pre-assembly and during shipping.

Materials

Component	Part	Material	Finish	UL Specification
Header	Insulator	PBT (glass-reinforced)	Black	UL94V-0
	Contact	Brass	Gold plating	—
	Metal fitting	Brass	Tin-plating	—
Crimp socket	Insulator	PBT (glass-reinforced)	Black	UL94V-0
In-line plug	Insulator	PBT (glass-reinforced)	Black	UL94V-0
Crimp contact	Contact	High conductivity copper alloy	Gold plating	—

Product Number Structure

Refer to the charts below for determining specific part number characteristics.

Please select connectors listed in this catalog when placing orders and be sure to check the latest delivery specifications at the time of ordering the product.

Connector

DF **60** - ***** **P** - **10.16** **DSA**

① ② ③ ④ ⑤ ⑥

① Series Name : D F	⑤ Pitch : 10. 16mm
② Series No. : 60	⑥ Type of housing DSA : straight pin header DS : right angle pin header
③ Number of contacts : 1, 2, 3, 4, 5, 6	
④ Connector type P: pin header	

Connector

DF **60** - ***** **S** - **10.16** **C**

① ② ③ ④ ⑤ ⑥

① Series Name : D F	⑤ Pitch : 10. 16mm
② Series No. : 60	⑥ Wiring type C : Crimp socket
③ Number of contacts S : 1, 2, 3, 4, 5, 6 EP : 2, 3, 4, 5	
④ Connector type S : socket EP : In-line plug	

Contact

DF **60** - **8** **SCFA**

① ②

① Applicable wire size 8 : AWG8 1012 : AWG10 ~ 12	② Packaging styles SCFA : Socket contact reel SCA : Socket contact, loose PCFA : In-line plug plug contact, reel PCA : In-line plug contact, loose
---	--

■ Straight pin header



PCB layout

(Recommended thickness of PCB: $t=1.6\pm0.1\text{mm}$)

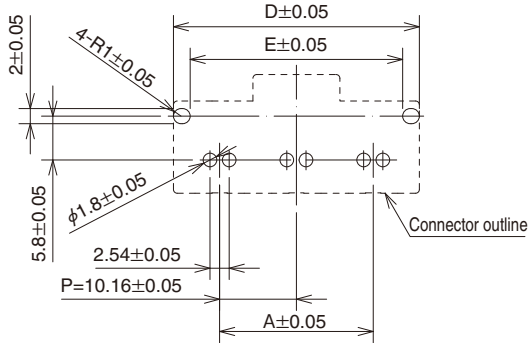

Headers with 1 to 4 contacts

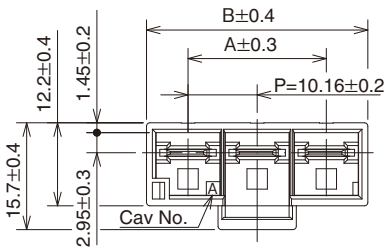

Headers with 5 to 6 contacts

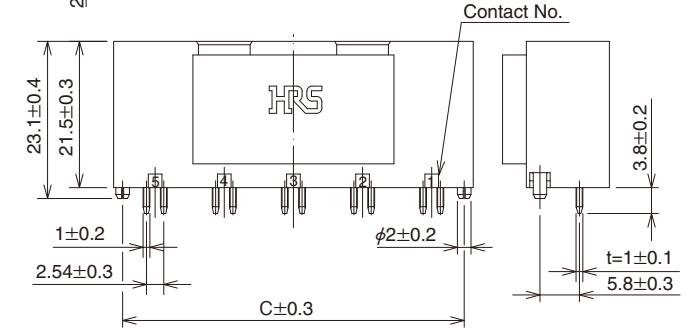
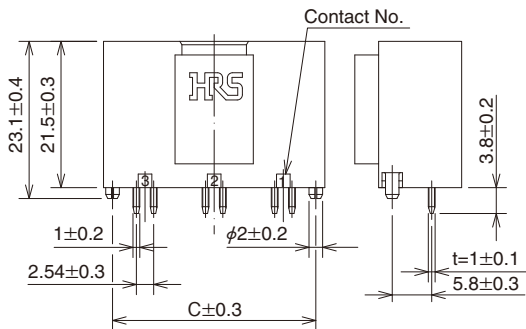
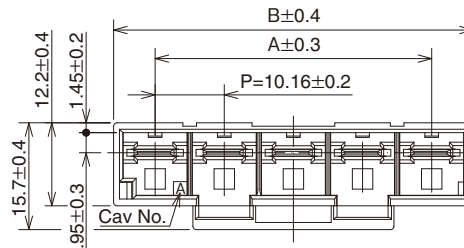

[Specification Number]
(26): gold plating, tray packaging

Unit: mm

Part Number	HRS No.	No. of Contacts	A	B	C	D	E	Quantity per package
DF60-1P-10.16DSA (26)	680-3004-5-26	1	—	15.2	9.55	12.2	7.78	160
DF60-2P-10.16DSA (26)	680-3005-8-26	2	10.16	22.36	19.71	22.36	17.94	96
DF60-3P-10.16DSA (26)	680-3001-7-26	3	20.32	32.52	29.87	32.52	28.1	64
DF60-4P-10.16DSA (26)	680-3006-0-26	4	30.48	42.68	40.03	42.68	38.26	48
DF60-5P-10.16DSA (26)	680-3007-3-26	5	40.64	52.84	50.19	52.84	48.42	32
DF60-6P-10.16DSA (26)	680-3008-6-26	6	50.8	63	60.35	63	58.58	32

(Note) Please place orders in full lot quantities.

Right angle pin header



PCB Layout

(Recommended thickness of PCB: $t=1.6\pm0.1$ mm)

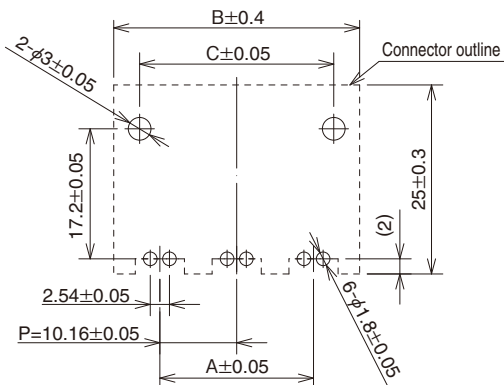

Headers with 1 to 4 contacts

Headers with 5 to 6 contacts

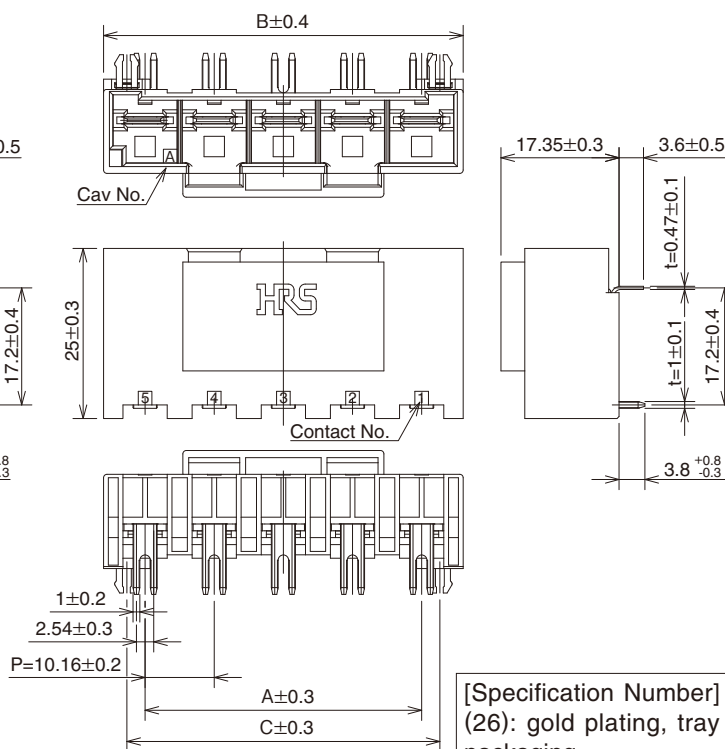
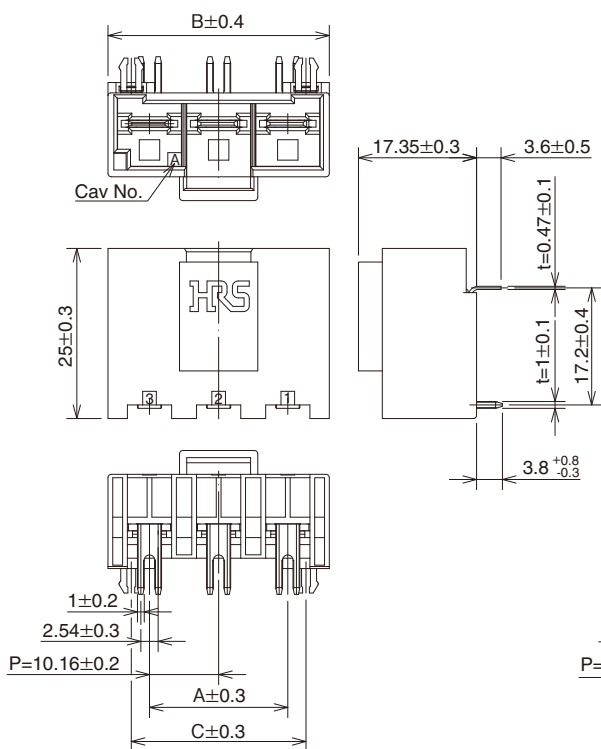

[Specification Number]
(26): gold plating, tray packaging

Unit: mm

Part Number	HRS No.	No. of Contacts	A	B	C	Quantity per package
DF60-1P-10.16DS(26)	680-3015-1-26	1	—	15.2	8.35	120
DF60-2P-10.16DS(26)	680-3016-4-26	2	10.16	22.36	15.51	72
DF60-3P-10.16DS(26)	680-3017-7-26	3	20.32	32.52	25.67	48
DF60-4P-10.16DS(26)	680-3018-0-26	4	30.48	42.68	35.83	36
DF60-5P-10.16DS(26)	680-3019-2-26	5	40.64	52.84	45.99	24
DF60-6P-10.16DS(26)	680-3020-1-26	6	50.8	63	56.15	24

(Note) Please place orders in full lot quantities.

■ Crimp socket



Sockets with 1 to 4 contacts

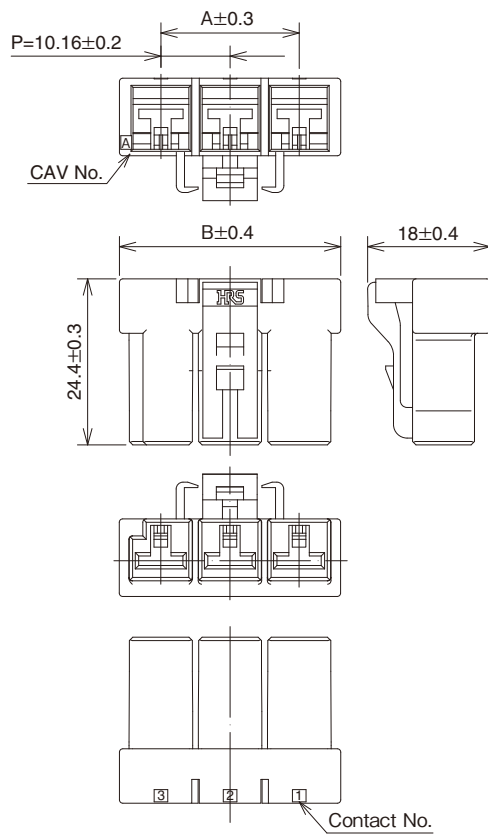

Sockets with 5 to 6 contacts

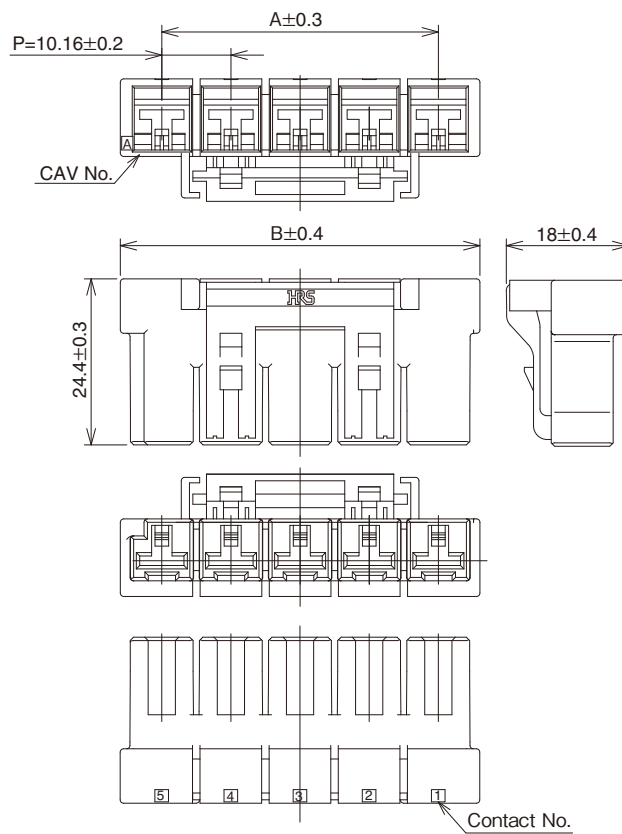

[Specification Number]
None: 1 package = 100 pieces

Unit: mm

Part Number	HRS No.	No. of Contacts	A	B
DF60-1S-10.16C	680-3009-9	1	—	15.8
DF60-2S-10.16C	680-3010-8	2	10.16	22.36
DF60-3S-10.16C	680-3002-0	3	20.32	32.52
DF60-4S-10.16C	680-3011-0	4	30.48	42.68
DF60-5S-10.16C	680-3012-3	5	40.64	52.84
DF60-6S-10.16C	680-3013-6	6	50.8	63

(Note) Please place orders in full lot quantities.

In-line plug



The torque value for attaching screws is 49N
Panel cutout

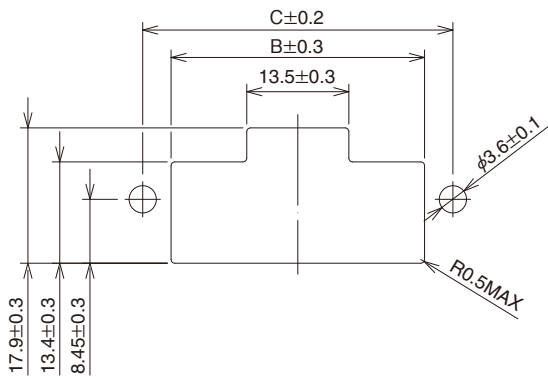

In-line plugs with 2 to 4 pos

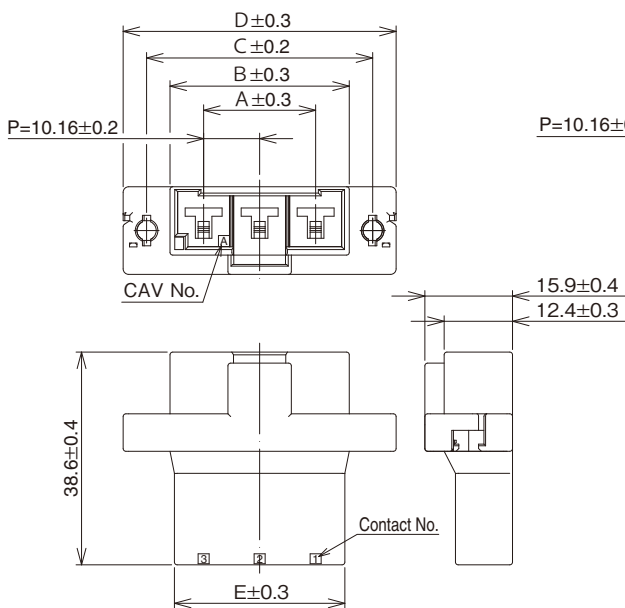

In-line plug with 5 pos.

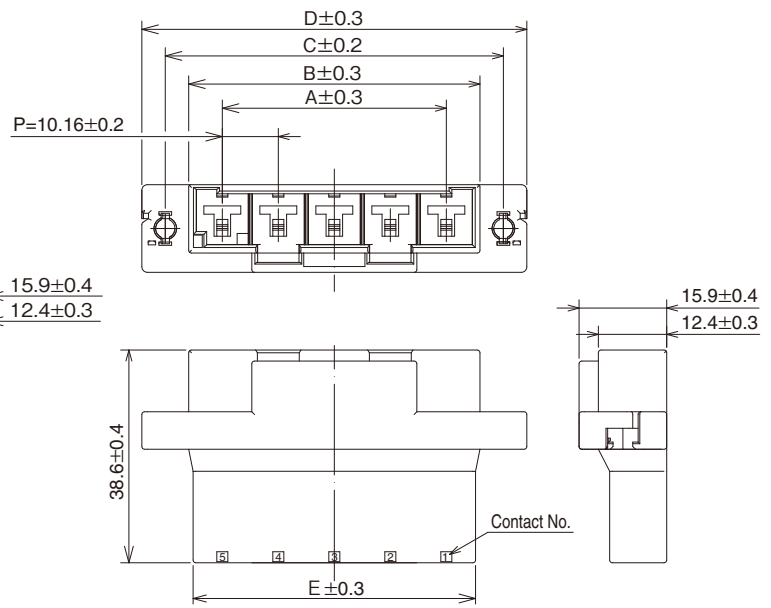

[Specification Number]
None: 1 package = 100 pieces

Unit: mm

Part Number	HRS No.	No. of Contacts	A	B	C	D	E
DF60-2EP-10.16C	680-3025-5	2	—	22.36	30.86	39.36	20.76
DF60-3EP-10.16C	680-3026-8	3	20.32	32.52	41.02	49.52	30.92
DF60-4EP-10.16C	680-3027-0	4	30.48	42.68	51.18	59.68	41.08
DF60-5EP-10.16C	680-3028-3	5	40.64	52.84	61.34	69.84	51.24

(Note) Please place orders in full lot quantities

■ Socket crimp contact

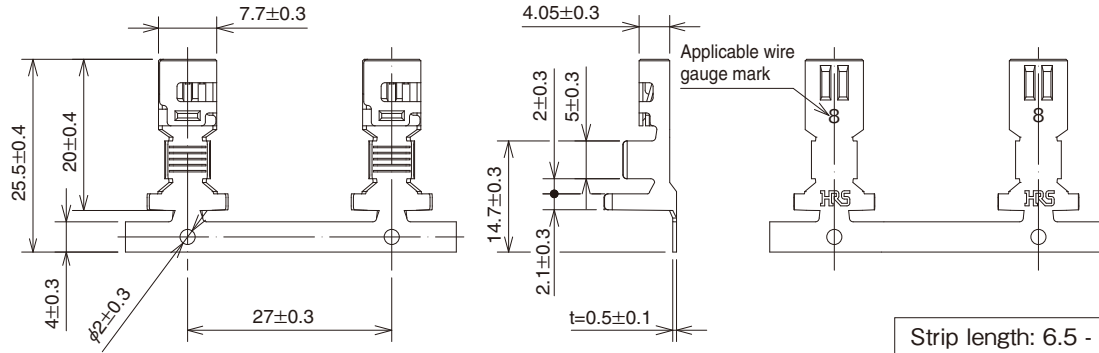

Strip length: 6.5 - 7.5mm

Part No.	HRS No.	Applicable wires					
		UL	Jacket Diameter	Wire size	Core structure	Package style	Quantity
DF60-8SCFA	680-3003-2	UL1283	4.9~7.8	AWG # 8	7/24/0.26	Reel	700
DF60-8SCA	680-3021-4					Loose	100
DF60-1012SCFA	680-3014-9	UL1015	4~5.2	AWG # 10	67/0.32	Reel	900
DF60-1012SCA	680-3022-7			AWG # 12	43/0.32	Loose	100

(Note) The applicable wires are tin-plated and annealed.

(Note) Please contact our Sales Department when using wires other than those listed.

■ Crimp contact for in-line plugs

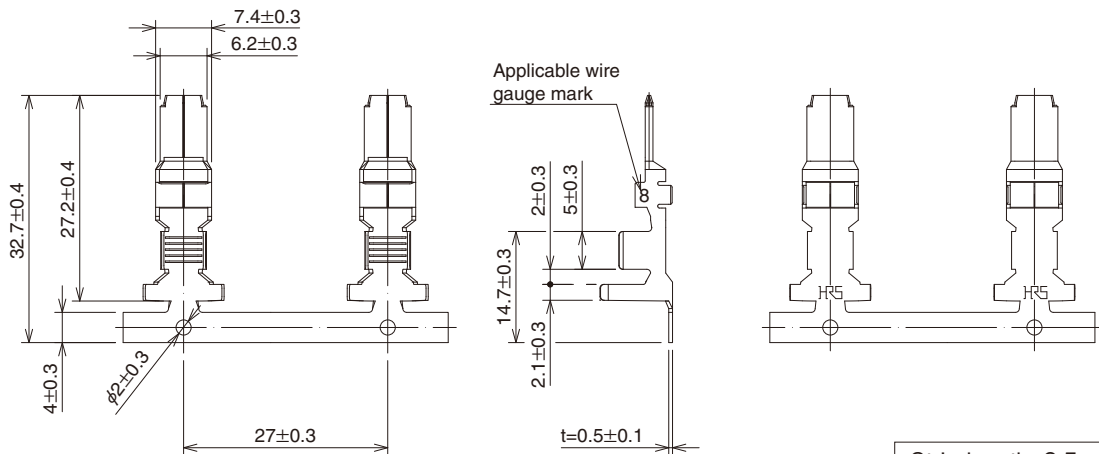

Strip length: 6.5 - 7.5mm

Part No.	HRS No.	Applicable wires					
		UL	Jacket Diameter	Wire size	Core structure	Package style	Quantity
DF60-8PCFA	680-3023-0	UL1283	4.9~7.8	AWG # 8	7/24/0.26	Reel	700
DF60-8PCA	680-3048-0					Loose	100
DF60-1012PCFA	680-3024-2	UL1015	4~5.2	AWG # 10	67/0.32	Reel	900
DF60-1012PCA	680-3049-3			AWG # 12	43/0.32	Loose	100

(Note) The applicable wires are tin-plated and annealed.

(Note) Please contact our Sales Department when using wires other than those listed.

◆ Applicable crimping tool

Item	Part Number	HRS No.	Applicable contact
Applicator	AP105-DF60-8 AP105-DF60-1012	CL901-4623-5 CL901-4624-8	DF60-8SCFA / PCFA DF60-1012SCFA / PCFA
Hand tool	HT103/DF60-8 HT103/DF60-1012	CL550-0302-7-00 CL550-0303-0-00	DF60-8SCA / PCA *Exclusive for UL1283 AWG8 DF60-1012SCA / PCA *Exclusive for UL1005 AWG10,12

(Note 1) Please use a press that generates 3.5tons.

(Note 2) Please contact our Sales Department when you are using crimp tools made by other manufacturers.

(Note 3) Please do the crimping operations according to the "Crimping work standards" and "Crimping condition table".

◆ Removing Contacts

- Contact extraction tool: precision screwdriver (flathead screwdriver with 1.4mm in width across flats)
- For Crimp contacts: DF60-8SC(F)A, DF60-1012SC(F)A, DF60-8PC(F)A, DF60-1012PC(F)A
- Procedure

Sectioned drawing of the housing

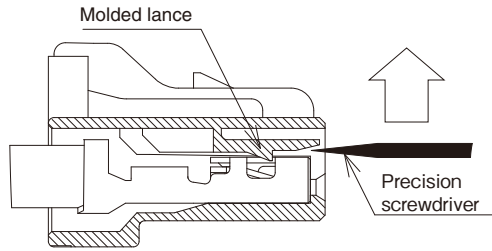

1. After unmating the parts, position the screwdriver to raise the lance as shown in the illustration.

Before attempting to remove any contacts, make sure that the power is switched off and the system is de-energized.

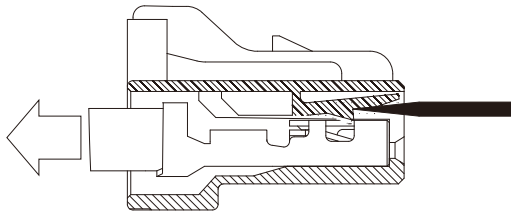

2. The lance needs to be raised sufficiently to allow the terminated wire to slip past it. The lance needs to be held up while at the same time pulling on the wire

Due to any previous repairs, the strength of the lance could have been compromised. Hirose recommends the use of a new crimp housing to assure proper performance.

Caution

Please be very careful when removing the contact work so that you don't become injured by the protruding part of the crimp contact.

◆ Precautions for use

1. The connector could be damaged if it is pulled out forcibly. When it is hard to pull out, push it in slightly first and then depress the lock and un-mate.
2. When thick, short sections of wire are used, the connector could be deformed due to the force of the wires' position. Route cables in such a way that they do not twist when being installed.
3. Make sure to turn off the power when mating or un-mating the connector.
4. Please do not touch any area around the contact part with your hand when the power is on; it could be very dangerous.
5. Please contact our Sales Department about the assembly procedure and the instruction manual.

◆ Rated values

Please avoid using the device above the rated values. Also, do not insert or pull out energized or "live" wires.

◆ Operating environment

Please contact us if you are designing this connector into environmental conditions where high and low temperatures are repeated.

◆ Mated dimensions

● Board-to-Wire Connection using the straight pin header

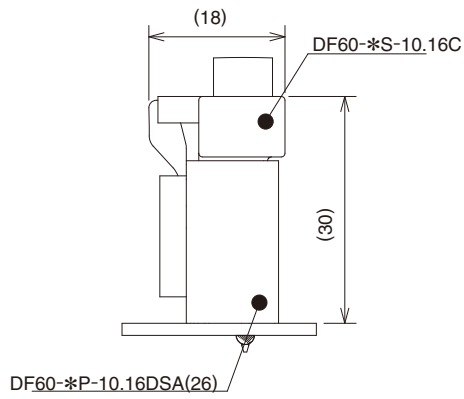

● Board-to-Wire Connection using the right angle pin header.

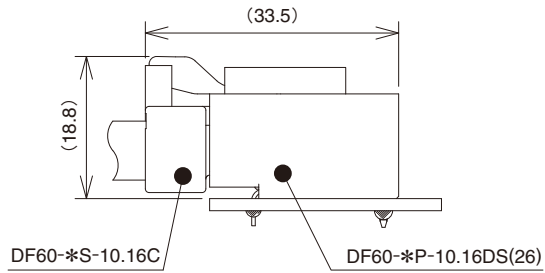

● In-line or Wire-to-Wire Connection

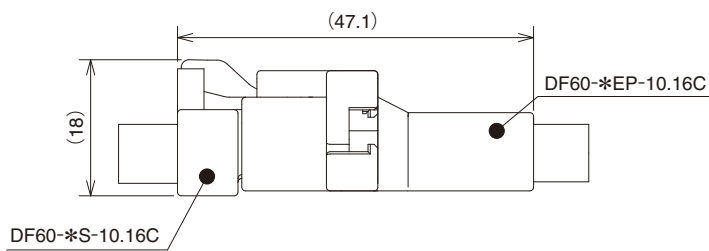

◆ Precautionary notes

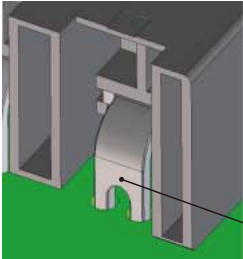
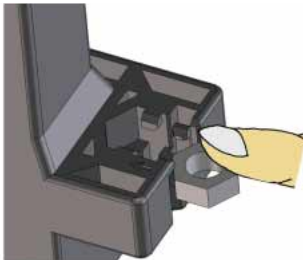
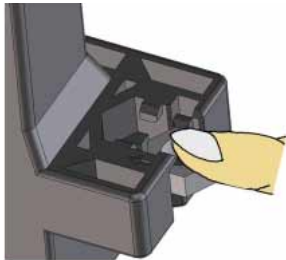
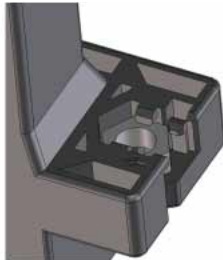
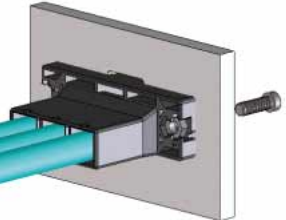
<p>1. Recommended soldering conditions</p>	<ul style="list-style-type: none"> ■ Soldering profile when using an automatic soldering device Soldering temperature: 260°C ; Soldering time: no more than 10 seconds ■ Hand soldering conditions Temperature of soldering iron: 350±10°C , soldering time: no more than 3 seconds
<p>2. Cleaning Conditions</p>	<p>Please refer to the "Nylon Connector Guide". Cleaning with IPA is allowed. (Other cleaning agents are not recommended due to the fact that it may change the push/pull feeling. Please contact us when you use other cleaning agents.)</p>
<p>3. Wiring condition</p>	<p>Please refer to the "Nylon Connector Guide" and "DF60 Harness procedure".</p>
<p>4. Important notes</p>	<ul style="list-style-type: none"> ■ Caution is required for mating and un-mating the connector without it being mounting on a PCB. Doing so can damage or deform the contacts. ■ During hand soldering, do not apply excess amounts flux which can migrate on to the connector. ■ This product may have a slight differences in color depending on the production lot. This difference does not have any influence on the performance. ■ Please refer to "DF60 Harness procedure" for the handling precautions during mating and un-mating operations.
<p>5. Handling instructions</p>	<p>Please refer to the "Nylon Connector Guide".</p>
<p>6. Right angle pin header Precautions for use</p>	<div style="display: flex; align-items: center;">  <div style="margin-left: 20px;"> <p>Since the lead mounting part has some exposed parts, please insure sufficient clearance when mounting other parts near this connector.</p> </div> </div>
<p>7. In-line connector Panel fixing operation</p>	<div style="display: flex; flex-wrap: wrap;"> <div style="width: 50%;"> <p>① Insert a M3 nut from the lateral direction.</p>  </div> <div style="width: 50%;"> <p>② Push the nut in the direction of the arrow.</p>  </div> <div style="width: 50%;"> <p>③ Nut insertion is then complete.</p>  </div> <div style="width: 50%;"> <p>④ Panel mounting is completed by installing a connector on the panel cutout hole and tightening with a M3 screw. Torque value is 49N-cm max.</p>  </div> </div>

USA:

HIROSE ELECTRIC (U.S.A.), INC. Headquarters
2688 Westhills Court, Simi Valley, CA 93065-6235
Phone : +1-805-522-7958
Fax : +1-805-522-3217
<http://www.hiroseusa.com>

USA:

HIROSE ELECTRIC (U.S.A.), INC. San Jose Office
3255 Scott Boulevard, Building 7, Suite 101
Santa Clara, CA 95054
Phone : +1-408-253-9640
Fax : +1-408-253-9641
<http://www.hiroseusa.com>

USA:

HIROSE ELECTRIC (U.S.A.), INC. Detroit Office (Automotive)
37677 Professional Center Drive, Suite #100C
Livonia, MI 48154
Phone : +1-734-542-9963
Fax : +1-734-542-9964
<http://www.hiroseusa.com>

THE NETHERLANDS:

HIROSE ELECTRIC EUROPE B.V.
Hogehillweg #8 1101 CC Amsterdam Z-O
Phone : +31-20-6557460
Fax : +31-20-6557469
<http://www.hiroseeurope.com>

GERMANY:

HIROSE ELECTRIC EUROPE B.V. German Branch
Herzog-Carl-Strasse 4 D-73760 Ostfildern
(Scharnhauser Park)
Phone : +49-711-4560-02-1
Fax : +49-711-4560-02-299
<http://www.hirose.de>

UNITED KINGDOM:

HIROSE ELECTRIC EUROPE B.V. UK Branch
22 Vincent Avenue, Crownhill Business
Centre, Crownhill, Milton Keynes, MK8 0AB
Phone : +44-1908-305750
Fax : +44-1908-305768
<http://www.hirose.co.uk>

CHINA:

HIROSE ELECTRIC TRADING (SHANGHAI) CO., LTD.
1601, Henderson Metropolitan, NO.300, East Nanjing
Road, Huangpu District, Shanghai, China 200001
Phone : +86-21-6391-3355
Fax : +86-21-6391-3335
<http://www.hirose-china.com.cn>

CHINA:

HIROSE ELECTRIC TRADING (SHANGHAI) CO., LTD. Beijing Branch
A1001, Ocean International Center, Building 56# East 4th
Ring Middle Road, Chao Yang District, Beijing, 100025
Phone : +86-10-5165-9332
Fax : +86-10-5908-1381
<http://www.hirose-china.com.cn>

CHINA:

HIROSE ELECTRIC TECHNOLOGIES (SHENZHEN) CO., LTD.
Room 09-13, 19/F, Office Tower Shun Hing Square, Di Wang Commercial Centre
5002, ShenNanDong Road, ShenZhen City, Guangdong Province, 518008
Phone : +86-755-8207-0851
Fax : +86-755-8207-0873
<http://www.hirose-china.com.cn>

HONG KONG:

HIROSE ELECTRIC HONGKONG TRADING CO., LTD.
Room 1001, West Wing, Tsim Sha Tsui Centre, 66
Mody Road, Tsim Sha Tsui East, Kowloon, Hong Kong
Phone : +852-2803-5338
Fax : +852-2591-6560
<http://www.hirose-hongkong.com.hk>

TAIWAN:

HIROSE ELECTRIC TAIWAN CO., LTD.
103 8F, No.87, Zhengzhou Rd., Taipei
Phone : +886-2-2555-7377
Fax : +886-2-2555-7350
<http://www.hirose-taiwan.com.tw>

KOREA:

HIROSE KOREA CO., LTD.
1261-10, Jeoungwhang-Dong, Shihung-City,
Kyunggi-Do 429-450
Phone : +82-31-496-7000, 7124
Fax : +82-31-496-7100
<http://www.hirose.co.kr>

SINGAPORE:

HIROSE ELECTRIC SINGAPORE PTE. LTD.
10 Anson Road #26-1 International Plaza
079903
Phone : +65-6324-6113
Fax : +65-6324-6123
<http://www.hirose-singapore.com.sg>

INDIA:

HIROSE ELECTRIC SINGAPORE PTE. LTD. Bangalore Liaison office
Unit No.03, Ground Floor, Explorer Building International Tech
Park Whitefield Road, Bangalore 560066 Karnataka, India
Phone : +65-6324-6113
Fax : +65-6324-6123
<http://www.hirose-singapore.com.sg>

INDIA:

HIROSE ELECTRIC SINGAPORE PTE. LTD Delhi Liaison Office
Suite No. 606 5th Floor SB Tower 1A/1 Sector
16 A Filmcity Noida 201301 Uttar Pradesh-India
Phone : +91-120-4804917
Fax : +91-120-4804949
<http://www.hirose.com/sg/>

MALAYSIA:

HIROSE ELECTRIC SINGAPORE PTE. LTD (Representative office)
1-10-07, Suntech @ Penang Cybercity (1164), Lintang
Mayang Pasir 3, 11950, Bayan Baru, Penang, Malaysia.
Phone : +604-619-2564
Fax : +604-619-2574
<http://www.hirose.com/sg/>



HIROSE ELECTRIC CO., LTD.

6-3, Nakagawa Chuoh-2-Chome, Tsuzuki-Ku, Yokohama-Shi 224-8540, JAPAN
TEL: +81-45-620-3526 Fax: +81-45-591-3726
<http://www.hirose.com>
<http://www.hirose-connectors.com>

X-ON Electronics

Largest Supplier of Electrical and Electronic Components

Click to view similar products for [Crimpers](#) category:

Click to view products by [Hirose](#) manufacturer:

Other Similar products are found below :

[576771-1](#) [576788-2](#) [010-0041](#) [010-0055](#) [010-0096](#) [604228-1](#) [M225202-37](#) [CT150-2-D02](#) [CT150-4-LY2](#) [CT150-6-RH07](#) [M322](#) [63484-3701](#)
[63800-0140](#) [63800-8355](#) [63811-3275](#) [63811-3376](#) [63811-6375](#) [63811-6475](#) [63811-7875](#) [63811-8175](#) [63811-8875](#) [63819-0475](#) [63819-1875](#)
[63819-2875](#) [63819-4375](#) [63819-4475](#) [63823-3475](#) [63823-5175](#) [63823-6375](#) [63823-8375](#) [63827-5375](#) [64001-0975](#) [64001-2175](#) [64001-4175](#)
[662903-2](#) [690142-4](#) [690602-6](#) [D38999/20WA98JB-LC](#) [7-1633664-2](#) [7-22278-0](#) [7-22280-5](#) [7-240641-3](#) [762637-1](#) [808714-1](#) [8-1633117-3](#)
[853721-6](#) [91362-1](#) [995-0001-187](#) [1-1633932-5](#) [999-50-020083](#)