

Application Note

**Medium Power Transistors and Rectifiers for
Power Management Applications**

ANI0117-01

© Koninklijke Philips Electronics N. V. 2003

All rights are reserved. Reproduction in whole or in part is prohibited without the prior written consent of the copyright owner. The information presented in this document does not form part of any quotation or contract, is believed to be accurate and reliable and may be changed without notice. No liability will be accepted by the publisher for any consequence of its use. Publication thereof does not convey nor imply any license under patent- or other industrial or intellectual property rights.



Application Note
Medium Power Transistors and Rectifiers for
Power Management Applications

ANI0117-01

Author(s):
Thomas Bluhm

Philips Semiconductors
BL General Application Discretes
Hamburg, Germany

Keywords:

power supply, power management, DC/DC converter, BISS transistor, MEGA Schottky rectifier, Low VCEsat

Number of pages : 18

Date: 2003-12-09

Contents

1. INTRODUCTION	7
2. DISTRIBUTED POWER SUPPLIES OR POINT-OF-LOAD PRINCIPLE.....	7
3. EXTENDED DESIGN CAPABILITIES AND IMPROVED CIRCUITS DUE TO NEW PRODUCT FAMILIES	8
Customer benefits.....	8
Low V_{CEsat} (BISS) transistors	8
Low V_F (MEGA) Schottky rectifiers.....	9
Resistor-equipped transistors (RETs).....	9
4. RECTIFICATION	10
Half and full wave rectification	10
Voltage multiplier	10
OR'ing diodes and reverse polarity protection.....	10
5. LINEAR POWER SUPPLIES.....	12
Simple linear voltage regulator	12
Voltage regulator IC extension	12
Low drop-out voltage regulator using standard semiconductors	12
Bipolar voltage supply.....	12
6. DC/DC CONVERSION	14
Step-up, step-down and step-up/down converter	14
Synchronous high current DC/DC converter	14
7. SUPPORTING CIRCUITS.....	16
Supply line switch	16
Battery charger	16
CCFL backlight power supply (Royer circuit)	16

I. INTRODUCTION

The need to improve electronic circuits' efficiency, to follow the ongoing trend to lower supply voltages and higher operating currents and to deal with multiple supply voltages has led to certain discrete semiconductor innovations. Their major advantages are smaller packages, thus lower cost, and lower heat generation, thus higher circuit efficiency.

Discrete semiconductors are used in large quantities in power management applications due to the following reasons:

- High current and power dissipation capability
- Capability to built circuits with excellent efficiency
- Optimised for specific applications
- Long-term availability, partly more than 20 years
- Excellent price - performance ratio

This application note provides information on the selection of medium power transistors and diodes, used in power management applications. The current capability of these products today is up to 5 A, the maximum operating voltage is as high as 100 V. Products which can further be found in power management applications like Low leakage current and High voltage (up to 300 V) diodes as well as Resistor-equipped transistors are also included.

If you do you find an appropriate product feel free to call your nearest sales representative. The products recommended in this brochure are only a few out of hundreds. Further, we continuously expand our portfolio for high-efficient power management applications focussing on Low V_{CEsat} (BISS) transistors, Low V_F (MEGA) Schottky rectifiers, Resistor-equipped transistors (RET's).

2. DISTRIBUTED POWER SUPPLIES OR POINT-OF-LOAD PRINCIPLE

Looking at PC-motherboard power supplies, or power management for digital still cameras, the tendency is the same: Voltages decrease while currents increase. Voltage drops to 0.9 V – due to further integration –, and current reaches values as high as 150 A – due to an increasing demand of power. Since the resulting voltage drop across the P.C.B. track is not negligible anymore the IC's supply voltage must be generated close to the load (point-of-load). In addition, integrated circuits require different voltages for optimal operation due to different IC technologies.

These requirements lead to distributed power supplies: One or more DC/DC converters and linear voltage regulators derive the IC's or sub-circuit's supply voltage from a battery or a system voltage (e.g. 12 V) which was generated by a AC/DC converter or an isolated DC/DC converter.

The table below provides some popular voltages, today. The picture to the right illustrates the distributed power supply principle exemplary on a digital still camera.

Domain	Voltage requirements
Controller system	
Core supply	1.5 / 1.8 / 2.5 V
Memory	1.25 / 2.5 V
Logic	3.3 / 5 V
Peripheral	
Standard I/O	3.3 / 5 V
Modem lines	±12 V
TV-tuner varicap	28 V
Camera CCD sensor	-7.5 & 15 V
LC Displays	±5 & 15 V
Automotive I/O	14 / 42 V
Industrial I/O	24 / 48 V

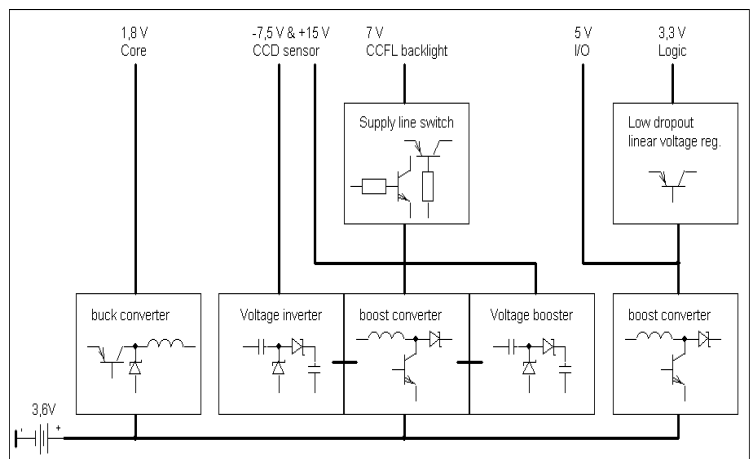

3. EXTENDED DESIGN CAPABILITIES AND IMPROVED CIRCUITS DUE TO NEW PRODUCT FAMILIES

Customer benefits

The short introduction into the product families below provides some background information on recent product developments and the resulting capabilities for the design of electronic circuits.

The customer benefits can be various:

Benefit	Example
– Transistors and rectifiers in small-signal packages are less expensive than their larger medium power equivalents	➤ SOT23 vs. SOT223
– Smaller packages need less board space	➤ 82 % savings comparing SOT223 to SOT23 and 75 % savings comparing SMA to SOD323
– Number of components and required board space decreases	➤ One double RET includes up to 6 components
– Circuit efficiency increases due to reduced power dissipation	➤ $P_C = I_C \times V_{CEsat}$ and $P_F = I_F \times V_F$
– Hot spots can be avoided since the maximum junction temperature decreases	➤ From 117 °C to 41 °C comparing a BDP32 vs. a PBSS4540Z at 3 A

Low V_{CEsat} (BISS¹) transistors

BISS transistors are high performance bipolar transistors. Nothing was left untouched during their development: Due to an optimised die layout – using the mesh-emitter technology – the efficiency of the active area was significantly increased by minimising the distributed base resistance. Secondly, the leadframe layout was optimised to improve the thermal performance. Further, the electrical resistances of the die metal, die attach and bond wires were minimised. As a result the collector-emitter saturation voltage was significantly reduced.

Thus, the performance of a SOT23 BISS transistor (e.g. PBSS4320T) is comparable to much larger medium power transistors in SOT223, or even better. Secondly, the BISS-technology enabled to design 500 mA transistors (PBSS2540F, PBSS3540F) in the ultra-small SOT490 (SC-89) package which measures only 1.6 x 0.8 mm². On top of that Philips Semiconductors had released the world’s first 2 A-transistor in an ultra-small SOT666 package (1.6 x 1.2 mm²) in early 2003.

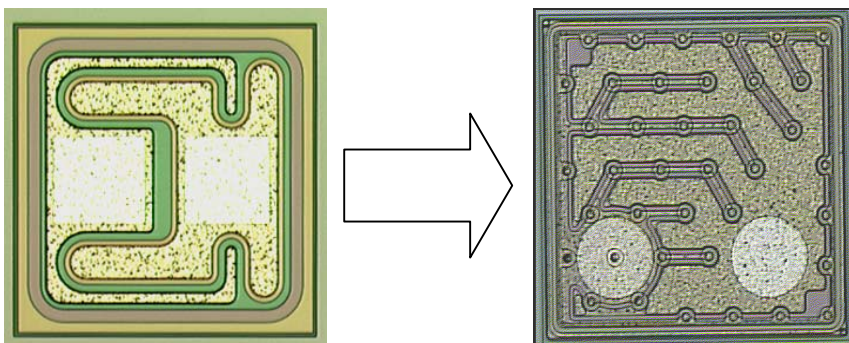

The active emitter area was significantly be increased using a mesh-emitter layout (right).

¹ BISS – Breakthrough In Small Signal

Low V_F (MEGA²) Schottky rectifiers

The forward voltage drop along with the flowing forward current causes the most significant part of diodes' losses. MEGA Schottky rectifiers are characterised by a significantly reduced forward voltage drop due to a new metal barrier, an optimised die layout and a minimised bond wire resistance.

These improvements enable Philips Semiconductors to offer Schottky rectifiers in the very small SOD323 (SC-76) and ultra-small (SOT666) packages which perform like much larger SOD123 and SMA rectifiers and are thus capable to replace them.

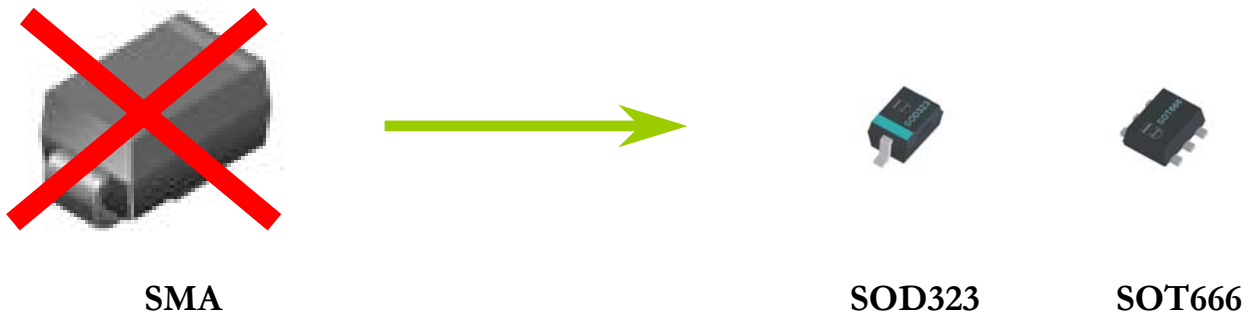

MEGA Schottky rectifiers in SOD323 and SOT666 are capable to replace much larger SMA rectifiers at comparable electrical performance.

Resistor-equipped transistors (RETs)

RETs are basically 100 mA-General Purpose Transistors equipped with one or two resistors. They thus reduce the number of external components and minimise the required board space. They are used to control IC inputs or to switch smaller loads like LEDs to give just two examples.

Philips Semiconductors' strength lies in offering a complete RETs portfolio including 16 resistance combinations in nine small signal packages. Double RETs are included in the very small SOT363 (SC-88) and the ultra-small SOT666 packages. At the end of 2003 already 241 types are available. By end of 2004 about 400 types will cover at least 90 % of the worldwide applications.

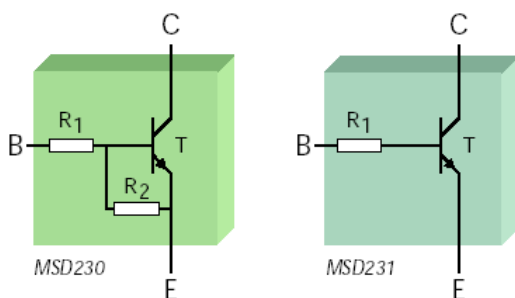

RETs are used to switch small loads or to control IC inputs

² MEGA – Maximum Efficiency General Application

4. RECTIFICATION

Half and full wave rectification

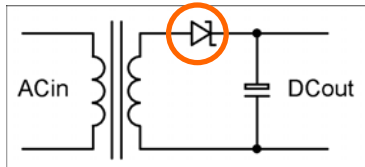

Half wave rectification

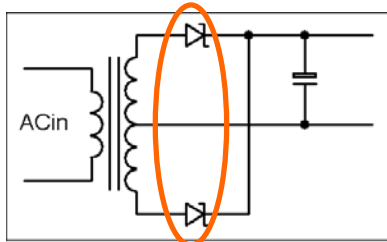

Full wave rectification

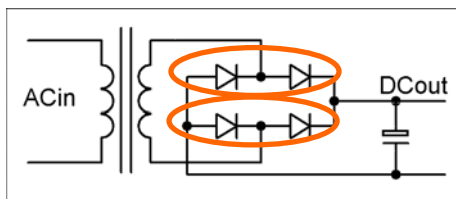

Full wave (bridge) rectification

- Application: Low cost mains supplied wall adapters, low cost battery chargers, forward and fly-back SMPS (e.g. UCC38xx-series, TEA15xx-series)
- AC signal may be mains voltage (110 / 230 V, 60 / 50 Hz) or derived from a DC/DC converter (50 kHz to 2 MHz)
- Select rectifiers or switching diodes for higher voltages, where forward voltage drop is negligible
- Select Schottky diodes for low voltages, high currents or high frequencies, where forward voltage drop and power dissipation is important
- Series connected (for full wave rectifier) or common cathode (for bridge rectifier) double diodes reduce component count and board space saving

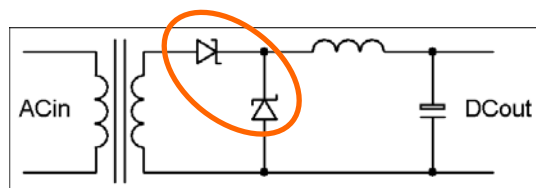

Forward converter secondary side

Voltage multiplier

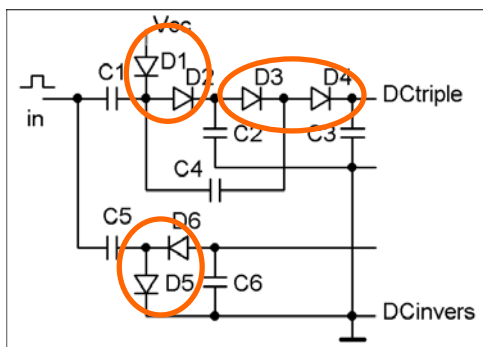

DC tripler and inverter used in TFT displays

- Application: Power supply for TFT displays and white LEDs
- Voltage doubler uses D1-2, C1-2; voltage tripler uses D1-3, C1-3
- Series connected double diodes for voltage doubler and triple isolated diodes for voltage tripler reduce component count and save board space
- AC signal may be derived from a DC/DC converter, a simple oscillator (e.g. multivibrator) or from mains voltage
- Select Low V_F Schottky diodes for low voltage drop
- Select Low leakage current diodes for lowest reverse current

OR'ing diodes and reverse polarity protection

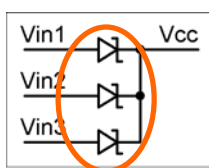

OR'ing configuration

- Application: Reverse polarity protection (single diode) and parallel operation of power supplies (multiple diodes) to avoid battery discharge or high cross-currents
- Select Low V_F (MEGA) Schottky rectifiers for lowest voltage drop
- Common cathode double diodes or triple isolated diodes reduce component count

Low V_F (MEGA) Schottky rectifiers

Package	Limiting values		Features V_{Fmax} @ I_F	Type(s)
	I_F	V_R		
SOT457 (SC-74)	1 A	60 V	650 mV @ 1 A	PMEG6010AED
SOD323 (SC-76)	2 A	10 V	350 mV @ 1 A	PMEG1020EA
	1.5 A	20 V	660 mV @ 1,5 A	PMEG2015EA
	1 A	20 V	550 mV @ 1 A	PMEG2010EA
	1 A	20 / 30 / 40 V	500 mV @ 1 A*)	PMEG2010BEA / PMEG3010BEA / PMEG4010BEA
	0.5 A	20 / 30 / 40 V	390 mV @ 0.5 A	PMEG2005AEA / PMEG3005AEA / PMEG4005AEA
SOD523 (SC-79)	1 A	20 V	620 mV @ 1 A	PMEG2010AEB
	0.2 A	30 V	480 mV @ 0.2 A	PMEG3002AEB
SOT666	2 A	10 V	350 mV @ 1 A	PMEG1020EV
	1.5 A	20 V	660 mV @ 1,5 A	PMEG2015EV
	1 A	20 V	550 mV @ 1 A	PMEG2010EV
	0.5 A	20 / 30 / 40 V	390 mV @ 0.5 A	PMEG2005AEV / PMEG3005AEV30 / PMEG4005AEV
SOD882	0.2 A	30 V	480 mV @ 0.2 A	PMEG3002AEL

*) PMEG2010BEA

Schottky diodes

Package	Limiting values		Features V_{Fmax} @ I_F	Configuration	Type(s)
	I_F	V_R			
SOT223 (SC-73)	1 A	25 / 40 / 60 V	450 mV @ 1 A	Double, series connected or common cathode	BAT120_ / BAT140_ / BAT160_*)
SOT23	0,2 A	30 V	600 mV @ 0,1 A		BAT754_*)
SOT363 (SC-88)	0.2 A	30 V	750 mV @ 0.1 A	Triple, isolated	BAT754L
	30 mA	15 V	700 mV @ 30 mA		1PS88SB82

*) Series connected: “_” = “S”, common cathode “_” = “C”

Low leakage current diodes

Package	Limiting values		Features I_R @ V_R	Configuration	Type
	I_F	V_R			
SOT23	0.215 A	75 V	5 nA @ 75 V	Single	BAS116
	0.160 A			Double, series connected	BAV199
SOD323	0.2 A			Single	BAS416
SOT323	0.135 A			Double, series connected	BAV199W

Switching diodes, special configurations

Package	Limiting values		Features t_{rr}	Configuration	Type
	I_F	V_R			
SOT363 (SC-88)	0.2 A	75 V	4 ns	Two double, series connected	BAV99S
				Triple isolated	BAS16VY

General purpose diodes $V_R > 100$ V

Package	Limiting values		Features t_{rr}	Configuration	Type
	I_F	V_R			
SOT23	0.2 A	150 V	50 ns	Single	BAS20
		200 V		Single	BAS21
				Double, series connected	BAV23S
SOT143	0.225 A	200 V		Double, isolated	BAV23
SOD323 (SC-76)	0.25 A	200 V		Single	BAS321
SOD523 (SC-79)	0.25 A	300 V		Single	BAS521
SOT457 (SC-74)	0.2 A	200 V		Tripple, isolated	BAS21VD
SOD27 (DO-35)	0.25 A	150 V		Single	BAV20
		200 V		Single	BAV21

5. LINEAR POWER SUPPLIES

Simple linear voltage regulator

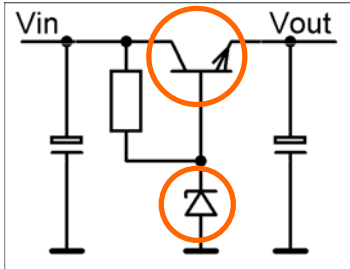

Low current linear voltage regulator

- Application: Low current voltage regulation and decoupling for sub-circuits (e.g. DC/DC controller ICs, pre-amplifier)
- Most simple voltage regulation solution
- Appropriate for low currents (<0.1 A) and low stability requirements
- No ripple or noise

Voltage regulator IC extension

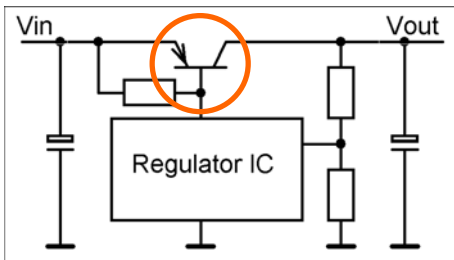

Current and power extension of linear voltage regulators

- Application: To extend current and power dissipation capabilities of LDOs (e.g. MAX687, LT1123, ADM666A) and DC/DC controller ICs with linear voltage regulators (e.g. MAX1778, MAX1865)
- Select Low V_{CEsat} (BISS) transistors due to high current gain and for lowest voltage drop
- Appropriate for currents up to 5 A
- No ripple or noise

Low drop-out voltage regulator using standard semiconductors

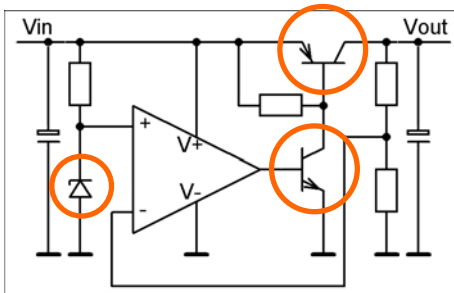

Voltage regulator uses standard semiconductors only

- Application: Linear low drop voltage regulator using only standard semiconductor
- Select Low V_{CEsat} (BISS) transistors as PNP pass transistor for lowest voltage drop
- Appropriate for currents up to 5 A
- No ripple or noise

Bipolar voltage supply

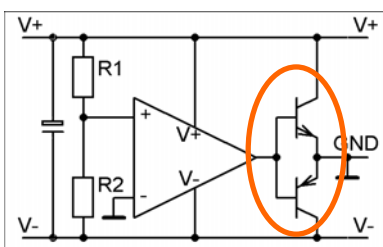

Bipolar voltage supply

- Application: Voltage supply for operational amplifiers and other circuits, which need a bipolar voltage
- Uses standard semiconductors only
- No ripple or noise

Low V_{CEsat} (BISS) transistors

Package	Limiting values		Features P_{tot}	$V_{CEsat,max}$ @ I_C	Polarity	Type
	I_C	V_{CEO}				
SOT223 (SC-73)	5 A	40 V	2 W **)	355 mV @ 5 A	NPN	PBSS4540Z
				375 mV @ 5 A	PNP	PBSS5540Z
	3 A	50 V		290 mV @ 2 A	NPN	PBSS4350Z
				300 mV @ 2 A	PNP	PBSS5350Z
SOT89 (SC-62)	5 A	40 V	1.4 W **)	355 mV @ 5 A	NPN	PBSS4540X
				375 mV @ 5 A	PNP	PBSS5540X
	3 A	20 / 50 V		310 mV @ 3 A***)	NPN	PBSS4320X / PBSS4350X
				300 mV @ 3 A***)	PNP	PBSS5320X / PBSS5350X
SOT457 (SC-74)	3 A	20 V	0.75 W **)	400 mV @ 3 A	PNP	PBSS5320D
SOT666	2 A	40 V	0.5 W *)	400 mV @ 2 A	NPN	PBSS4240V
				530 mV @ 2 A	PNP	PBSS5240V
SOT154 (TO-92)	3 A	50 V	0.83 W	290 mV @ 2 A	NPN	PBSS4350S
				300 mV @ 2 A	PNP	PBSS5350S

*) on 1 cm² collector mounting pad **) on 6 cm² collector mounting pad

Medium power transistors

Package	Limiting values		Features P_{tot}	Polarity	Types
	I_C	V_{CEO}			
SOT223 (SC-73)	1 A	20 / 45 / 60 / 100 V	1.35 W *)	NPN	BCP68 / BCP54 / BCP55 / BCP56
				PNP	BCP69 / BCP51 / BCP52 / BCP53
SOT89 (SC-62)	1 A	20 / 45 / 60 / 100 V	1.35 W **)	NPN	BC868 / BCX54 / BCX55 / BCX56
				PNP	BC869 / BCX51 / BCX52 / BCX53
SOT154 (TO-92)	1 A	20 / 45 / 60 / 80 V	0.83 W	NPN	BC368 / BC635 / BC637 / BC639
				PNP	BC369 / BC636 / BC638 / BC640

*) on 1 cm² collector mounting pad **) on 6 cm² collector mounting pad

NPN/PNP double transistors

Package	Limiting values		Features P_{tot}	Technology	Type
	I_C	V_{CEO}			
SOT457 (SC-74)	1.1 A	40 V	0.6 W *)	Low V_{CEsat} (BISS)	PBSS4240DPN
	0.5 A	45 V	0.6 W *)	General purpose	BC817DPN
SOT363 (SC-88)	0.5 A	15 V	0.3 W	Low V_{CEsat} (BISS)	PBSS2515YPN
	0.1 A	45 V	0.3 W	General purpose	BC847BPN
SOT666	0.5 A	15 V	0.3 W	Low V_{CEsat} (BISS)	PBSS2515VPN
	0.1 A	45 V	0.3 W	General purpose	BC847BPN

*) on 1 cm² collector mounting pad

Zener diodes

Package	Limiting values		Features P_{tot}	V_Z	Type
	I_F	V_{CEO}			
SOT23	0.2 A		0.25 W	2.4 to 75 V, E24 series	BZX84 series
SOD323 (SC-76)	0.25 A		0.3 W	2.4 to 75 V, E24 series	BZX384 series
SOD523 (SC-79)	0.2 A		0.3 W	2.4 to 15 V, E24 series	BZX585 series
SOD27 (DO-35)	0.25 A		0.5 W	2.4 to 75 V, E24 series	BZX79 series

6. DC/DC CONVERSION

Step-up, step-down and step-up/down converter

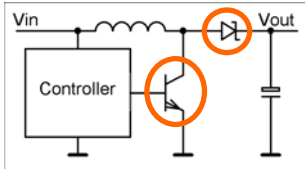

Traditional boost converter

- Application: Low and medium power step-up, step-down and step-up/down DC/DC converter
- Select Low V_{CEsat} (BISS) transistors for lowest voltage drop
- Select Low V_F (MEGA) Schottky rectifiers for lowest forward voltage
- Appropriate for currents up to 5 A

Synchronous high current DC/DC converter

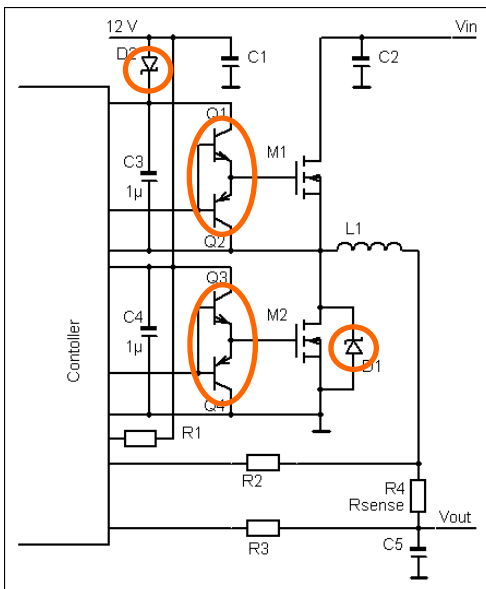

Synchronous DC/DC converter

- Application: Synchronous DC/DC converter on motherboards and in SMPS modules
- D1: Free-wheeling diode conducts while both MOSFETs are switched off
- Select Low V_F (MEGA) Schottky rectifiers for lowest voltage drop
- D2: Boosting diode provides driving voltage for the high-side driver together with C1
- Select Schottky diode for low voltage drop
- Q1/Q2, Q3/Q4: Complementary MOSFET driver reduce MOSFET switching times
- Select switching transistors for standard applications
- Select Low V_{CEsat} (BISS) transistors for faster switching due to higher current gain (h_{FE})
- Select double transistors to reduce component count and board space saving

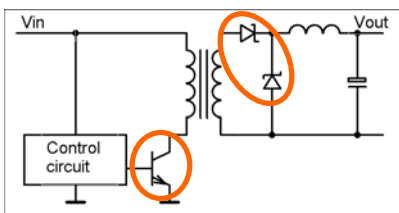

Forward converter

- Application: Isolated forward converter for telecom infrastructure and automotive applications
- Select Low V_{CEsat} (BISS) transistors for lowest voltage drop
- Select Low V_F (MEGA) Schottky rectifiers for lowest forward voltage

NPN/PNP double transistors

Package	Limiting values		Features		Type
	I_C	V_{CEO}	P_{tot}	Technology	
SOT457 (SC-74)	1.1 A	40 V	0.6 W ^{*)}	Low V_{CEsat} (BISS)	PBSS4240DPN
	0.5 A	45 V	0.6 W ^{*)}	General purpose	BC817DPN
SOT363 (SC-88)	0.5 A	15 V	0.3 W	Low V_{CEsat} (BISS)	PBSS2515YPN
	0.1 A	45 V	0.3 W	General purpose	BC847BPN
SOT666	0.5 A	15 V	0.3 W	Low V_{CEsat} (BISS)	PBSS2515VPN
	0.1 A	45 V	0.3 W	General purpose	BC847BVN

^{*)} on 1 cm² collector mounting pad

Low V_F (MEGA) Schottky rectifiers

Package	Limiting values		Features $V_{Fmax} @ I_F$	Type(s)
	I_F	V_R		
SOT457 (SC-74)	1 A	60 V	650 mV @ 1 A	PMEG6010AED
SOD323 (SC-76)	2 A	10 V	350 mV @ 1 A	PMEG1020EA
	1.5 A	20 V	660 mV @ 1,5 A	PMEG2015EA
	1 A	20 V	550 mV @ 1 A	PMEG2010EA
	1 A	20 / 30 / 40 V	500 mV @ 1 A*)	PMEG2010BEA / PMEG3010BEA / PMEG4010BEA
SOD523 (SC-79)	1 A	20 V	620 mV @ 1 A	PMEG2010AEB
	0.2 A	30 V	480 mV @ 0.2 A	PMEG3002AEB
SOT666	2 A	10 V	350 mV @ 1 A	PMEG1020EV
	1.5 A	20 V	660 mV @ 1,5 A	PMEG2015EV
	1 A	20 V	550 mV @ 1 A	PMEG2010EV

*) PMEG2010BEA

Low V_{CEsat} (BISS) transistors

Package	Limiting values		Features P_{tot}	$V_{CEsat,max} @ I_C$	Polarity	Type(s)
	I_C	V_{CEO}				
SOT223 (SC-73)	5 A	40 V	2 W **)	355 mV @ 5 A	NPN	PBSS4540Z
				375 mV @ 5 A	PNP	PBSS5540Z
	3 A	50 V		290 mV @ 2 A	NPN	PBSS4350Z
				300 mV @ 2 A	PNP	PBSS5350Z
SOT89 (SC-62)	5 A	40 V	1.4 W **)	355 mV @ 5 A	NPN	PBSS4540X
				375 mV @ 5 A	PNP	PBSS5540X
	3 A	20 / 50 V		310 mV @ 3 A***)	NPN	PBSS4320X / PBSS4350X
				300 mV @ 3 A***)	PNP	PBSS5320X / PBSS5350X
SOT457 (SC-74)	3 A	20 V	0.75 W **)	400 mV @ 3 A	PNP	PBSS5320D
SOT23	2 A	20 / 50 V	0.48 W*)	210 mV @ 2 A***)	NPN	PBSS4320T / PBSS4350T
				210 mV @ 2 A***)	PNP	PBSS5320T / PBSS5350T
	1 A	60 V / 100 V		0.4 W*)	250 mV @ 1 A****)	NPN
SOT666	2 A	40 V	0.5 W *)	330 mV @ 1 A****)	PNP	PBSS5160T / PBSS9160T
				400 mV @ 2 A	NPN	PBSS4240V
				530 mV @ 2 A	PNP	PBSS5240V
SOT54 (TO-92)	3 A	50 V	0.83 W	290 mV @ 2 A	NPN	PBSS4350S
				300 mV @ 2 A	PNP	PBSS5350S

*) on 1 cm² collector mounting pad**) on 6 cm² collector mounting pad

***) PBSSxx20x

****) PBSSxx60T

Medium power transistors

Package	Limiting values		Features P_{tot}	Polarity	Types
	I_C	V_{CEO}			
SOT223 (SC-73)	1 A	20 / 45 /	1.35 W *)	NPN	BCP68 / BCP54 / BCP55 / BCP56
		60 / 100 V		PNP	BCP69 / BCP51 / BCP52 / BCP53
SOT89 (SC-62)	1 A	20 / 45 /	1.35 W **)	NPN	BC868 / BCX54 / BCX55 / BCX56
		60 / 100 V		PNP	BC869 / BCX51 / BCX52 / BCX53
SOT54 (TO-92)	1 A	20 / 45 /	0.83 W	NPN	BC368 / BC635 / BC637 / BC639
		60 / 80 V		PNP	BC369 / BC636 / BC638 / BC640

*) on 1 cm² collector mounting pad**) on 6 cm² collector mounting pad

7. SUPPORTING CIRCUITS

Supply line switch

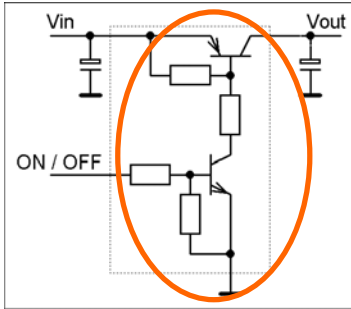

Supply line switch

- Application: Devices where either power sequencing is important for proper work (e.g. TFT displays) or sub-circuits shall be switched off when not needed to save battery power (e.g. laptop computers)
- Select BISS Loadswitches as ready-to-use solution and tight space requirements
- Select Low V_{CEsat} (BISS) transistors as PNP pass transistor for lowest voltage drop
- Select (double) Resistor-equipped transistors to reduce component count and to save P.C.B. space (PDTA-, PDTC-, PUMx- and PEMx-series)
- Select double devices for tightest space requirements and reduced placement costs

Battery charger

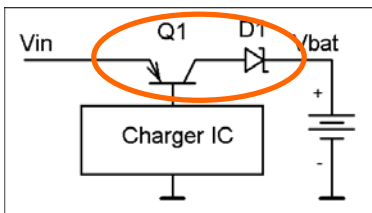

Battery charger with discharge protection diode

- Application: Pass transistor to extend current and power dissipation of battery charger ICs (e.g. TEA110x. 4-cell Ni-MH / NiCd battery charger; MAX1898 and LTC1734. 1-cell Li-ion battery charger)
- Add Low V_F Schottky rectifier to avoid battery discharge in case of an input source short circuit (MAX1898) or Low leakage current diode for minimum battery discharge
- Select Low V_{CEsat} (BISS) transistors due to high current gain and for lowest dropout voltage
- Appropriate for currents up to 5 A

CCFL backlight power supply (Royer circuit)

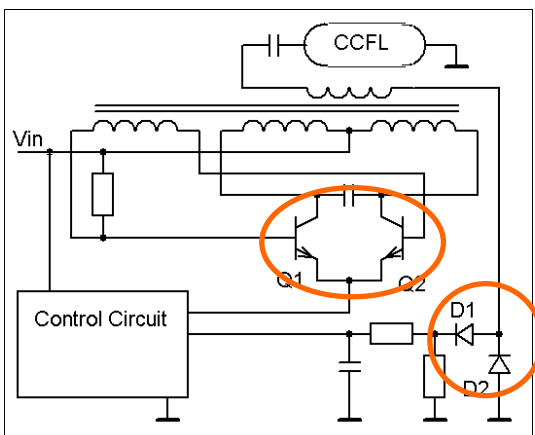

Royer circuit for CCFL backlight power supply

- Application: Push-pull (Royer) stage (Q1/Q2) for CCFL backlight power supply for TFT displays in laptops, PDAs and TFT-monitors and rectifier (D1/D2) for voltage feedback
- Control circuit incorporates a switching regulator (e.g. LT1186F, UCC3972) to drive the two transistor push-pull stage
- Stand-by function for the UCC3972 to be build using double Resistor-equipped transistors (PUMD- or PEMD-series)

BISS Loadswitches

Package	Limiting values		Features $V_{CEsat,max} @ I_C$	Type(s)
	I_C	V_{CEO}		
SOT666	0.5 A	15 V	250 mV @ 0.5 A	PNP Low V_{CEsat} (BISS) transistor and NPN RET
SOT363 (SC-88)	0.1 A	50 V	200 mV @ 50 mA	PNP General purpose transistor and NPN RET

Low V_{CEsat} (BISS) transistors

Package	Limiting values		Features P_{tot}	$V_{CEsat,max} @ I_C$	Polarity	Type(s)
	I_C	V_{CEO}				
SOT223 (SC-73)	5 A	40 V	2 W **)	355 mV @ 5 A	NPN	PBSS4540Z
				375 mV @ 5 A	PNP	PBSS5540Z
SOT89 (SC-62)	3 A	20 / 50 V	1.4 W **)	310 mV @ 3 A***)	NPN	PBSS4320X / PBSS4350X
				300 mV @ 3 A***)	PNP	PBSS5320X / PBSS5350X
SOT23	2 A	20 / 50 V		210 mV @ 2 A	NPN	PBSS4320T / PBSS4350T
				210 mV @ 2 A	PNP	PBSS5320T / PBSS5350T
SOT666	2 A	40 V	0.5 W *)	400 mV @ 2 A	NPN	PBSS4240V
				530 mV @ 2 A	PNP	PBSS5240V
SOT54 (TO-92)	3 A	50 V	0.83 W	290 mV @ 2 A	NPN	PBSS4350S
				300 mV @ 2 A	PNP	PBSS5350S

*) on 1 cm² collector mounting pad**) on 6 cm² collector mounting pad

***) PBSSxx20x

Resistor-equipped transistors (RETs)

Package	Limiting values		Features R_1, R_2	Configuration	Polarity	Type(s)
	I_C	V_{CEO}				
various	0.1 A	50 V	1 k Ω –	single	NPN	PDTC-series
			100 k Ω	single	PNP	PDTA-series
SOT363 (SC-88)				double	NPN/PNP	PUMD-series
SOT666				double	NPN/PNP	PEMD-series

Low V_F (MEGA) Schottky rectifiers

Package	Limiting values		Features $V_{Fmax} @ I_F$	Type(s)
	I_F	V_R		
SOT457 (SC-74)	1 A	60 V	650 mV @ 1 A	PMEG6010AED
SOD323 (SC-76)	1 A	20 V	550 mV @ 1 A	PMEG2010EA
			500 mV @ 1 A*)	PMEG2010BEA
SOD523 (SC-79)	0.2 A	30 V	480 mV @ 0.2 A	PMEG3002AEB
SOT666	1 A	20 V	550 mV @ 1 A	PMEG2010EV

Low leakage current diodes

Package	Limiting values		Features $I_R @ V_R$	Configuration	Type
	I_F	V_R			
SOT23	0.215 A	75 V	5 nA @ 75 V	Single	BAS116
SOD323	0.2 A			Single	BAS416

Double, series connected switching diodes

Package	Limiting values		Features t_{rr}	Configuration	Type
	I_F	V_R			
SOT23	0.215 A	75 V	4 ns	Double, series connected	BAV99
SOT323	0.1 A			Double, series connected	BAV99W
SOT363 (SC-88)	0.2 A			Two double, series connected	BAV99S

Further information:

Low V_{CEsat} (BISS) transistors

- Leaflet: Breakthrough in small signal, Low V_{CEsat} transistors selection guide (9397 750 11275)
- AN10116: Breakthrough in small signal – Low V_{CEsat} transistors and their applications

Low V_F (MEGA) Schottky rectifier

- Leaflet: Schottky diodes selection guide (9397 750 09967)
- Leaflet: MEGA Schottky diodes selection guide (9397 750 10821)
- AN10230: The PMEG1020EA and PMEG2010EA MEGA Schottky diodes – a pair designed for high efficiency rectification

Resistor-equipped transistors (RETs)

- Leaflet: Resistor-equipped transistors (RETs) – family overview and selection guide (9397 750 11248)

Contact: Thomas Bluhm, Application Support Manager Business Line General Application Discretets (BLGA) Philips Semiconductors GmbH, Stresemannalle 101, D-22529 Hamburg Tel: +49-40 56 13-18 04, email: Thomas.Bluhm@Philips.com

X-ON Electronics

Largest Supplier of Electrical and Electronic Components

Click to view similar products for [nxp](#) manufacturer:

Other Similar products are found below :

[MC13211R2](#) [PCA9518PW,112](#) [LFSTBEB865X](#) [MC33399PEFR2](#) [PCA9551PW,112](#) [MC34825EPR2](#) [PCF8583P](#) [MC68340AB16E](#)
[MC8640DTVJ1250HE](#) [EVBCRTOUCH](#) [MC9S08PT16AVLC](#) [MC9S08PT8AVTG](#) [MC9S08SH32CTL](#) [MCF54415CMJ250](#) [MCIMX6Q-SDB](#)
[MCIMX6SX-SDB](#) [74ALVC125BQ,115](#) [74HC4050N](#) [74HC4514N](#) [MK21FN1M0AVLQ12](#) [MKV30F128VFM10](#) [FRDM-K66F](#) [FRDM-](#)
[KW40Z](#) [FRDM-MC-LVBLDC](#) [PESD18VF1BSFYL](#) [PMF63UNEX](#) [PSMN4R0-60YS,115](#) [HEF4028BPN](#) [RAPPID-567XFSW](#)
[MPC565MVR56](#) [MPC574XG-176DS](#) [MPC860PCVR66D4](#) [BCV61A,215](#) [BGU8052X](#) [BT137-600E](#) [BT139X-600.127](#) [BUK7628-100A118](#)
[BUK765R0-100E.118](#) [BZT52H-B9V1.115](#) [BZV85-C3V9.113](#) [BZX79-C47.113](#) [P5020NSE7VNB](#) [S12ZVML12EVBLIN](#) [SCC2692AC1N40](#)
[LPC1785FBD208K](#) [LPC2124FBD64/01](#) [LS1020ASN7KQB](#) [LS1020AXN7HNB](#) [LS1020AXN7KQB](#) [LS1043ASE7PQA](#)