

<b>LPZ</b> RS485 0 <sub>A</sub> -3 RS485Q 0 <sub>A</sub> -3 SL RS485 0 <sub>B</sub> -3	<b>FULL MODE</b> Bonding + Equipment Protection
<b>SIGNAL/ TELECOM</b> TEST CAT D + C + B	<b>ENHANCED</b> Low let-through voltage
<b>LOW IN-LINE RESISTANCE</b>	<b>HIGH BANDWIDTH</b>
<b>ESP SL RS485 ULTRA SLIM 7 mm WIDTH</b>	<b>ESP RS485Q ULTRA COMPACT 18 mm WIDTH</b>

Combined Category D, C, B tested protector (to BS EN 61643) specifically designed for RS 485 and Fieldbus applications, such as Profibus DP. For use at boundaries up to LPZ 0<sub>A</sub> (ESP RS485 & ESP RS485Q), or LPZ 0<sub>B</sub> (ESP SL RS485) protect against flashover (typically the service entrance location) through to LPZ 3. Available as standard ESP RS485 format, or compact ESP RS485Q and Slim Line ESP SL RS485 versions for installations where a high number of lines require protection.

## Features and benefits

- ✓ Very low let-through voltage (enhanced protection to BS EN 62305) between all lines - Full Mode protection
- ✓ Full mode design capable of handling partial lightning currents as well as allowing continual operation of protected equipment
- ✓ Repeated protection in lightning intense environments
- ✓ 45 MHz bandwidth greatly exceeds 12 Mbps maximum speeds
- ✓ Low in-line resistance minimises reductions in signal strength
- ✓ Suitable for earthed or isolated screen systems
- ✓ Built-in DIN rail foot for simple mounting to top hat DIN rails
- ✓ Convenient earthing through DIN foot and/or earth terminal
- ✓ ESP RS485 can be flat mounted on base or side
- ✓ ESP RS485 and ESP RS485Q have colour coded terminals for quick and easy installation check
- ✓ ESP SL RS485 has ultra slim 7 mm width ideal for compact protection of large numbers of lines (e.g. process control installations)
- ✓ ESP SL RS485 includes two stage removable protection module with simple quick release mechanism allowing partial removal for easy line commissioning and maintenance as well as full removal for protection replacement
- ✓ ESP SL RS485 includes optional LED status indication - add L suffix to part number - i.e. ESP SL RS485L

The ESP SL 'Slim Line' Series is also available for protection of 3-wire and RTD applications (ESP SL/3W & ESP SL RTD). The ESP SL X Series has approvals for use in hazardous areas.

## Installation

Connect in series with the signal line either near where it enters or leaves the building or close to the equipment being protected ensuring it is very close to the system's earth star point. Install protectors either within an existing cabinet/cubicle or in a separate enclosure.

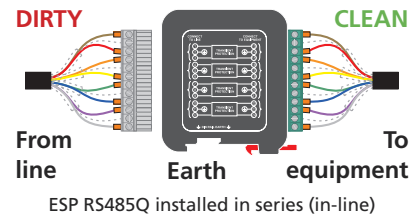
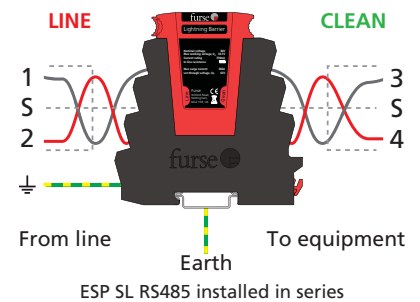
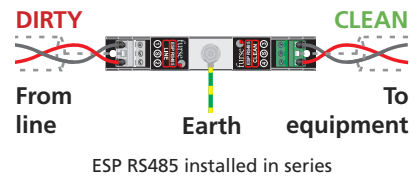

## Accessories

Replacement module for ESP SL RS485

**ESP SLRS485/M**

Standard module replacement

**ESP SLRS485/B**

Base replacement

Combined Mounting/Earthing kits for ESP RS485

**CME 4** For up to 4 x ESP RS485

**CME 8** For up to 8 x ESP RS485

**CME 16** For up to 16 x ESP RS485

**CME 32** For up to 32 x ESP RS485

For weatherproof enclosures, please contact us.

# NEW ESP RS485, RS485Q & SL RS485 Series

## Technical specification

Electrical specification	NEW ESP RS485	NEW ESP SL RS485	NEW ESP RS485Q
Nominal voltage <sup>1</sup>		15 V	
Maximum working voltage $U_c^2$		16.7 V	
Current rating (signal)		300 mA	
In-line resistance (per line $\pm 10\%$ )		1 $\Omega$	
Bandwidth (-3 dB 50 $\Omega$ system)		45 MHz	

Transient specification	ESP RS485	ESP SL RS485	ESP RS485Q
<b>Let-through voltage</b> (all conductors) <sup>3</sup> Up			
C2 test 4 kV 1.2/50 $\mu$ s, 2 kA 8/20 $\mu$ s to BS EN/EN/IEC 61643-21		55.0 V	
C1 test 1 kV, 1.2/50 $\mu$ s, 0.5 kA 8/20 $\mu$ s to BS EN/EN/IEC 61643-21		42.0 V	
B2 test 4 kV 10/700 $\mu$ s to BS EN/EN/IEC 61643-21		27.2 V	
5 kV, 10/700 $\mu$ s <sup>4</sup>		28.2 V	
<b>Maximum surge current</b>			
D1 test 10/350 $\mu$ s to BS EN/EN/IEC 61643-21	- per signal wire 2.5 kA - per pair 5 kA	1.25 kA 2.5 kA	2.5 kA 5 kA
8/20 $\mu$ s to ITU-T K.45:2003, IEEE C62.41.2:2002	- per signal wire - per pair	10 kA 20 kA	

Mechanical specification	ESP RS485	ESP SL RS485	ESP RS485Q
Temperature range		-40 to +80 °C	
Connection type	Screw terminal	Screw terminal	Pluggable 12 way screw terminal
Conductor size (stranded)	2.5 mm <sup>2</sup>	4 mm <sup>2</sup>	2.5 mm <sup>2</sup>
Earth connection	M6 stud	Via DIN rail or 4 mm <sup>2</sup> earth terminal	Via DIN rail or M5 threaded hole in base of unit
Case material	ABS UL94 V-0	FR polycarbonate UL94 V-0	ABS UL94 V-0
Weight - unit - packaged (per 10)	0.08 kg 0.85 kg	0.08 kg 0.85 kg	0.1 kg 1.3 kg
Dimensions			

<sup>1</sup> Nominal voltage (DC or AC peak) measured at < 10  $\mu$ A.

<sup>2</sup> Maximum working voltage (DC or AC peak) measured at < 5 mA.

<sup>3</sup> The maximum transient voltage let-through of the protector throughout the test ( $\pm 10\%$ ), line to line & line to earth, both polarities. Response time < 10 ns.

<sup>4</sup> Test to IEC 61000-4-5:2006, ITU-T (formerly CCITT) K.20, K.21 and K.45, Telcordia GR-1089-CORE, Issue 2:2002, ANSI TIA/EIA/IS-968-A:2002 (formerly FCC Part 68).

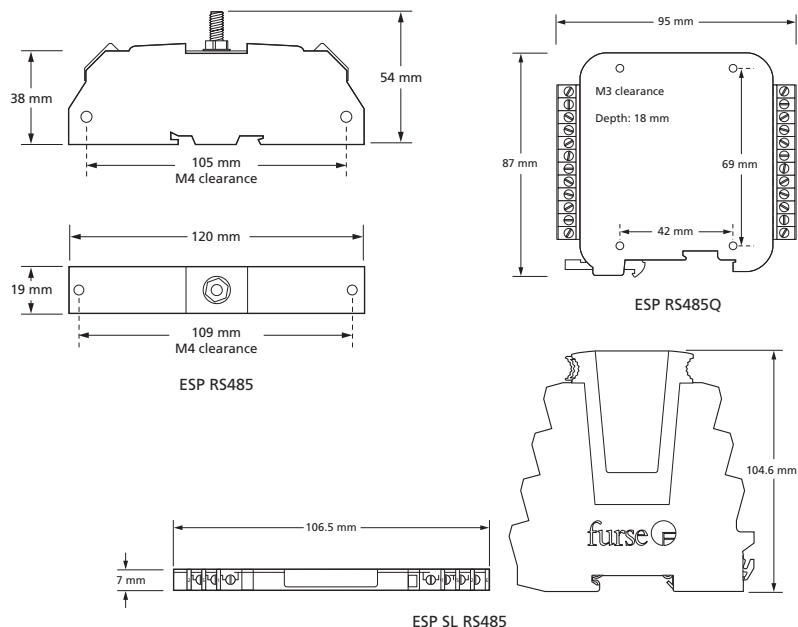

## **X-ON Electronics**

Largest Supplier of Electrical and Electronic Components

*Click to view similar products for [furse manufacturer](#):*

Other Similar products are found below :

[WBX4](#) [ESP 06D](#) [ESP30D](#) [ESPTN/BX](#) [ESP240-5A](#)