

APHC-12704-S

Peltier cooler module

Data sheet

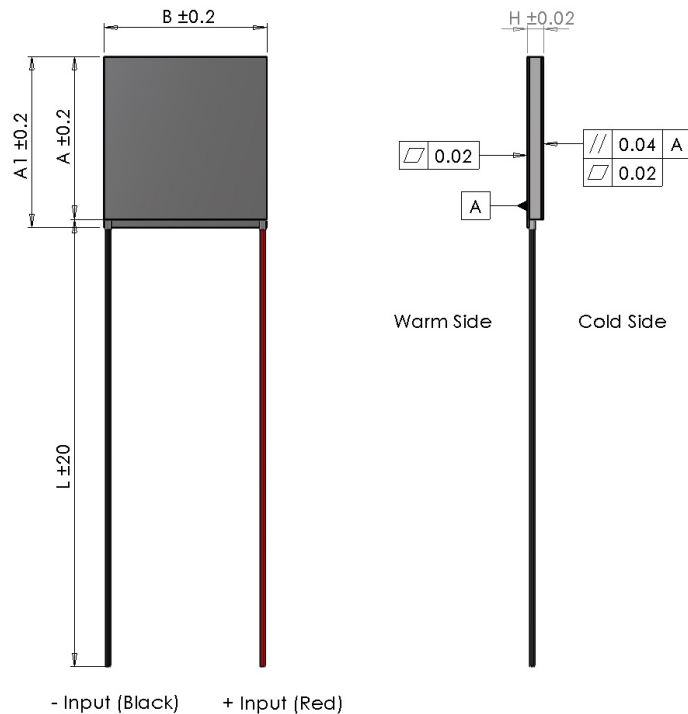

Features

- RoHs and Reach 161 compliant
- Solid-state reliability
- Built with high temperature solder with the ability to withstand $< 200^{\circ}\text{C}$ assembly processing temperatures for short periods of time
- High integrity nickel diffusion barriers on elements
- High strength for rugged environments
- Porched style for enhanced leadwire strength
- Sealed & lapped for multi-module applications

I_{max}	[A]	3.7
V_{max}	[Vdc]	14.7
$P_{\text{c max}}$	[W]	36
ACR	[Ω]	3.2
ΔT_{max}	[$^{\circ}\text{C}$]	66
A	[mm]	30
Al	[mm]	30
B	[mm]	34
H	[mm]	3.33
L	[mm]	100
Wire	AWG	20

- (At hot side temperature $T_{\text{h}} = 27^{\circ}\text{C} / 300\text{K}$, under dry N_2)
- $P_{\text{c max}}$ = Cooling power at $\Delta T = 0$ and $I = I_{\text{max}}$
- ΔT_{max} = Temperature difference at $I = I_{\text{max}}$ and $P_{\text{c}} = 0$
- Max hot side temperature $T_{\text{h}} = 200^{\circ}\text{C}$ for best long term performance
- Max mounting pressure: 1.5MPa
- Wires: UL-style 1569, 105oC (Unstripped)



APHC-I2704-S

Peltier cooler module

Data sheet - At hot side temperature 25°C

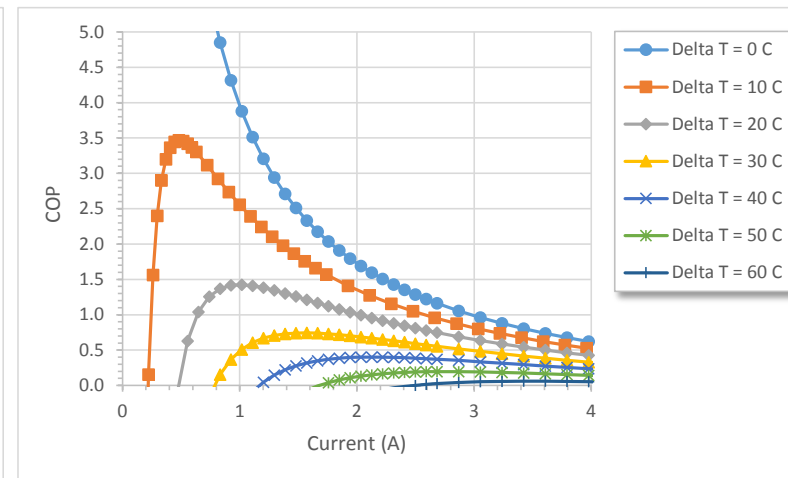
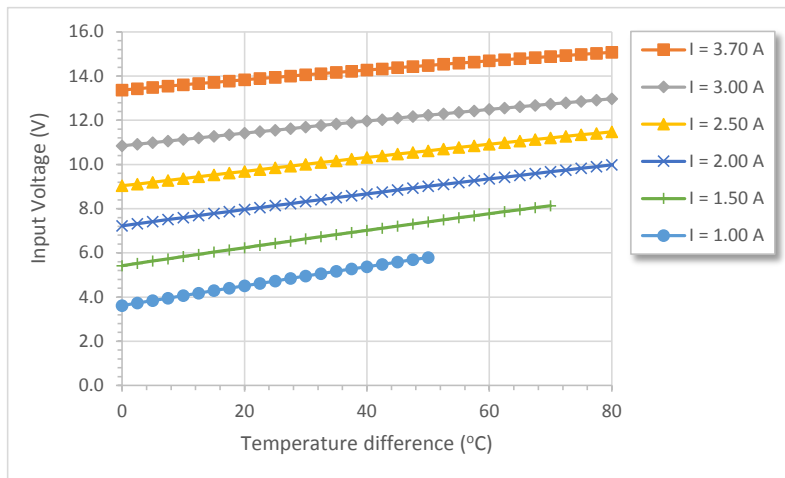
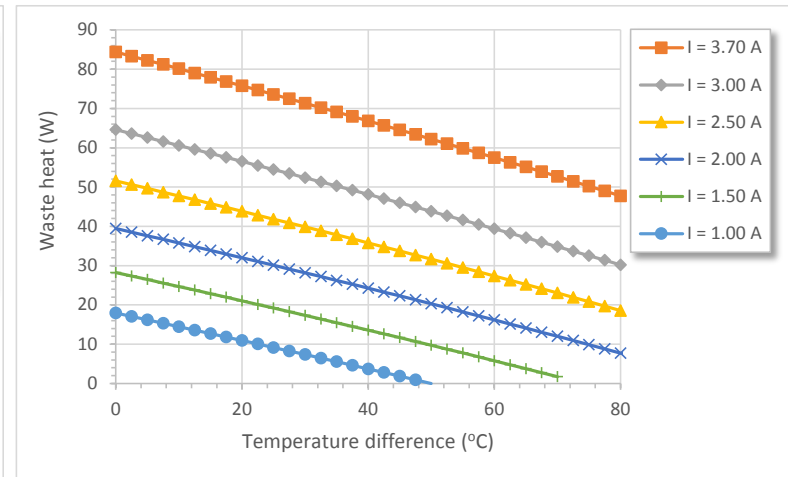
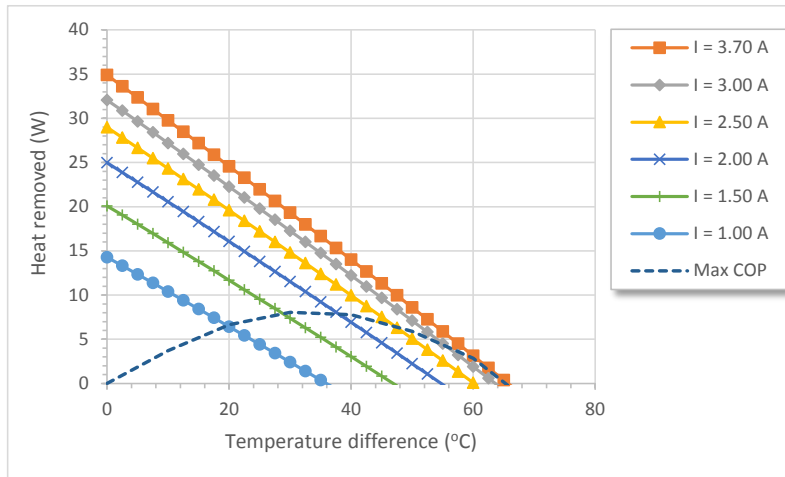

APHC-12704-S

Peltier cooler module

Data sheet - At hot side temperature 50°C

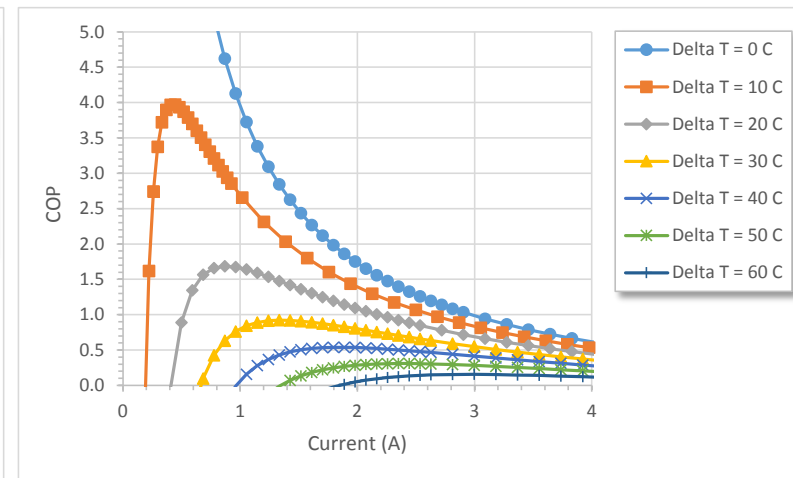
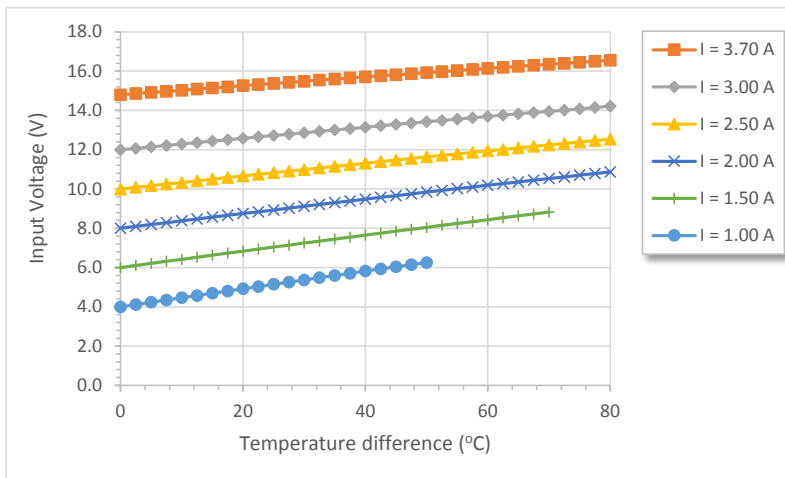
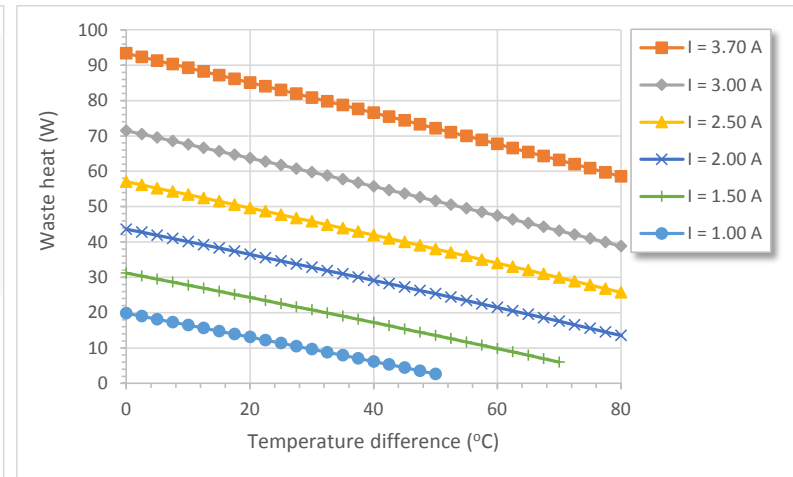
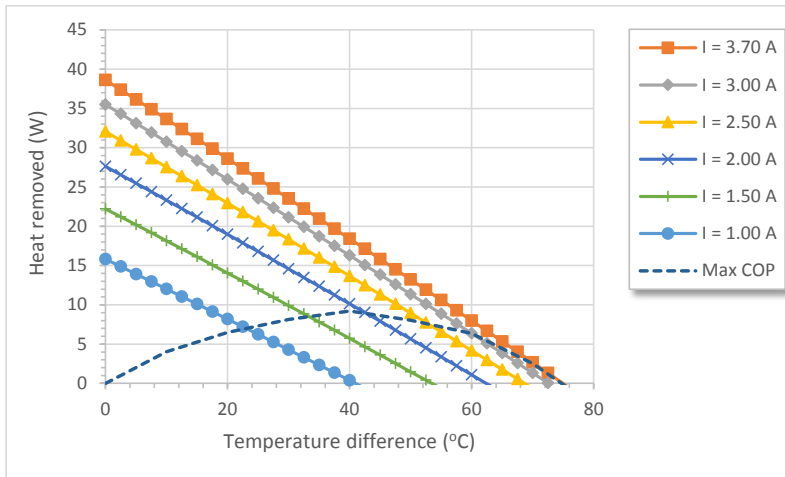

APHC-I2704-S

Peltier cooler module

Data sheet - At hot side temperature 75°C

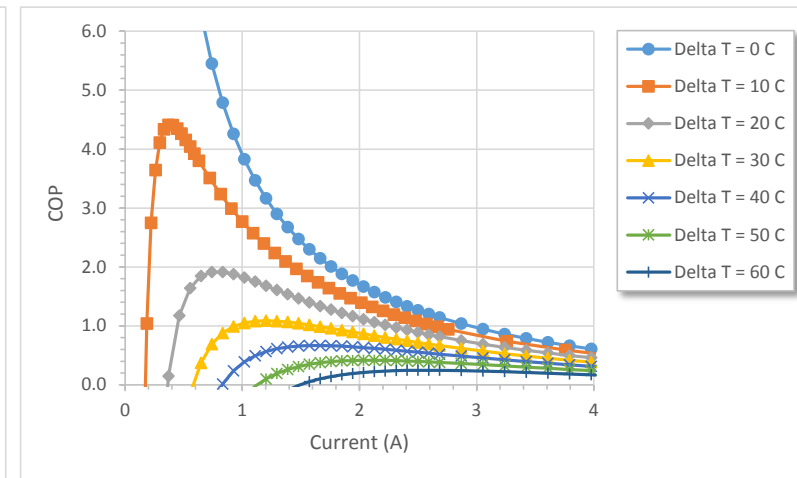
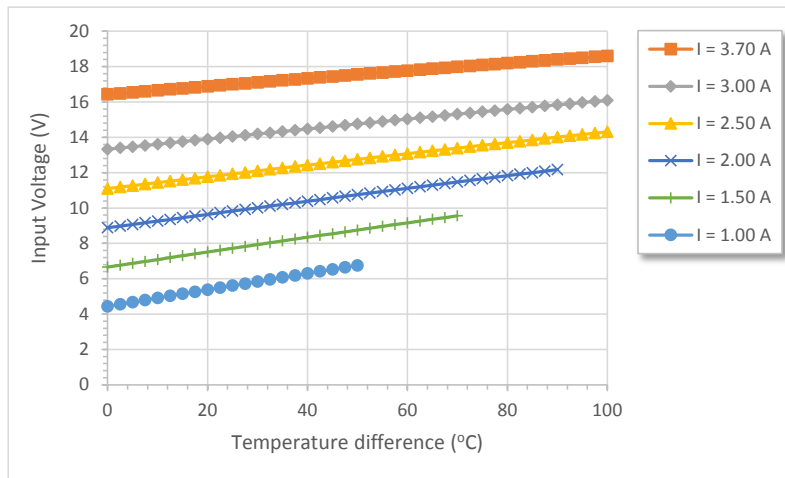
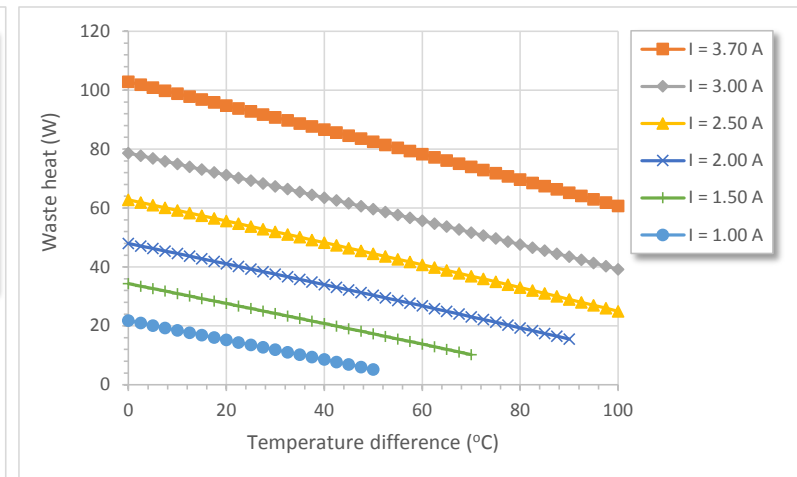
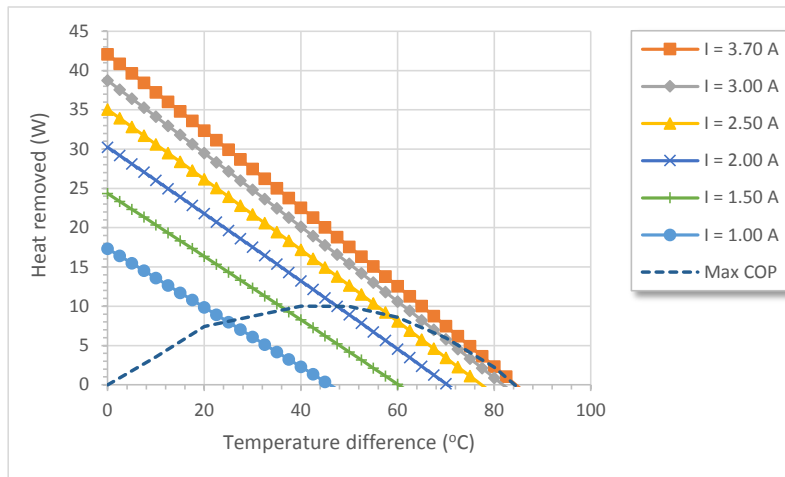

X-ON Electronics

Largest Supplier of Electrical and Electronic Components

Click to view similar products for [european thermodynamics manufacturer](#):

Other Similar products are found below :

[AP3-070-20-25](#) [APHC-12706-S](#) [SF-06-150-S](#) [APH-031-10-13-S](#)