

apPICation's

AP7 - 4 Channel DVM with RS232 Output Farnell Order code 120-121

Circuit Diagram

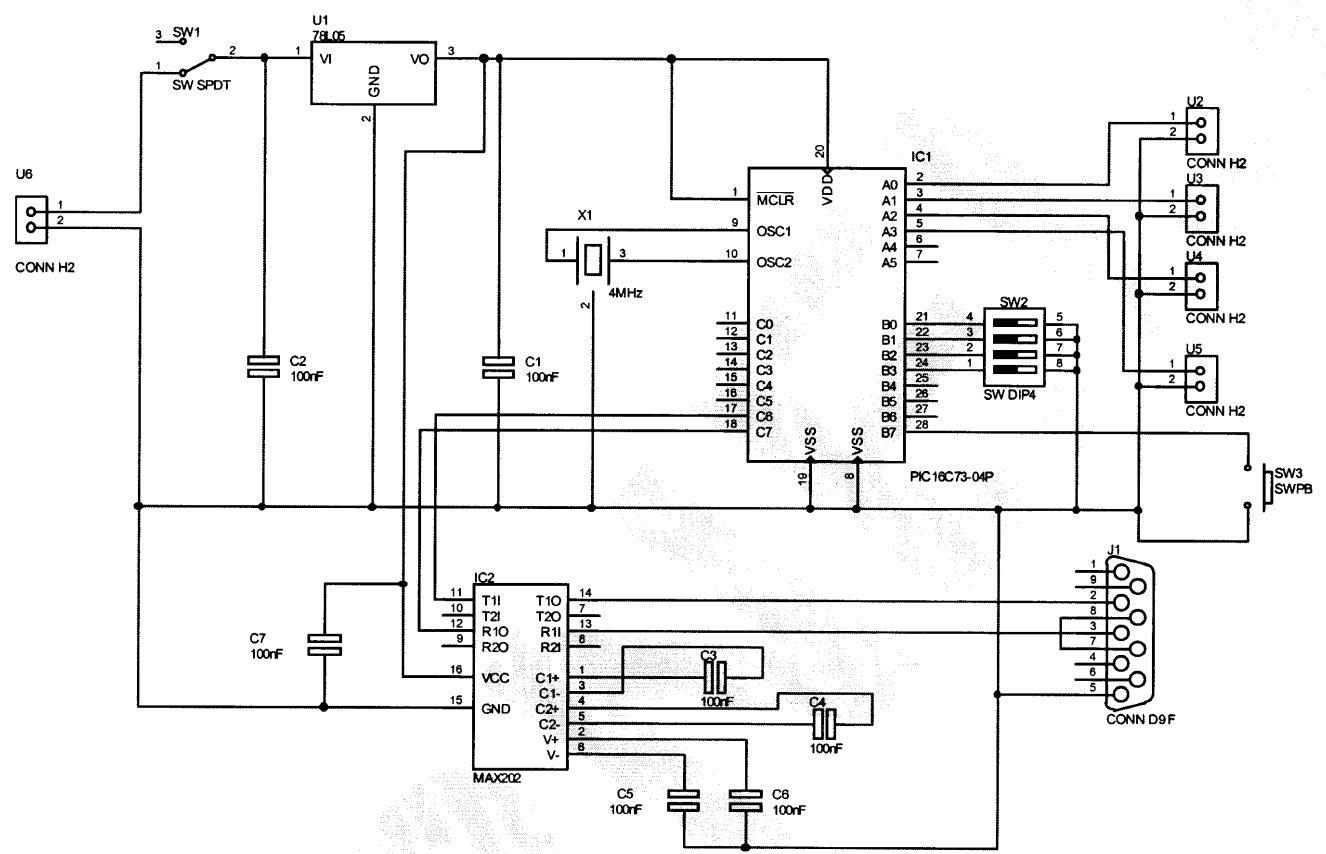

Construction

Insert the two links adjacent to and underneath the battery holder before attaching the battery holder.

The connector strips U2-5 should be joined together prior to insertion into the board.

For added strength, a small bolt could also be used to hold the battery connector in position

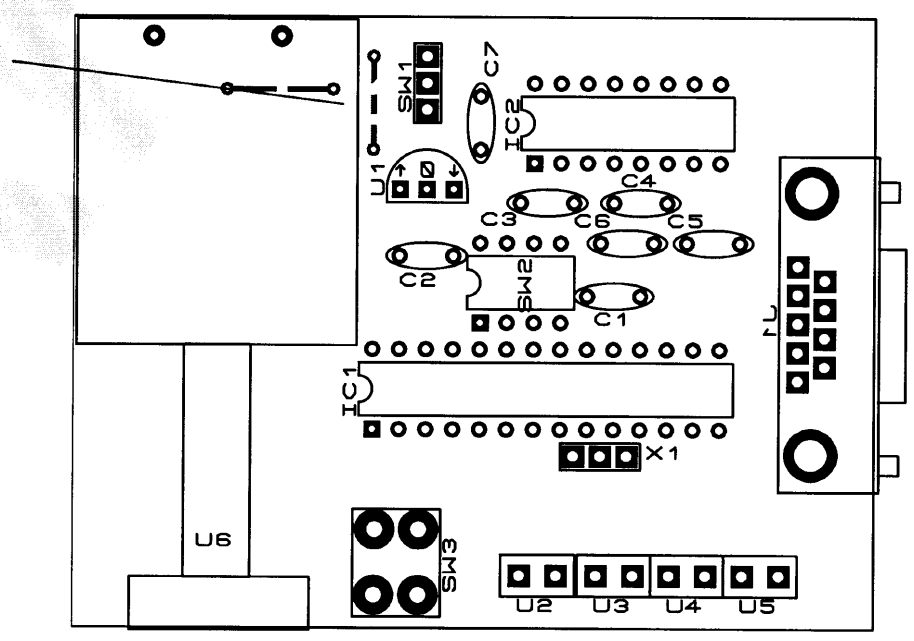

Operation

On power up the software determines the baud rate which is selected by switch positions 1 & 2. Pressing the button will cause an immediate read of all 4 channels. Holding the switch will give a continuous read. Sending a # from a PC will start a read sequence which is repeated every second. The \$ symbol will stop the logging function. The data from the logger can be captured on a PC using a comms program such as Windows Terminal. Such a program has the ability to capture and save data in text format to disk. This text file can then be imported into a spreadsheet package and the data then graphed.

SW3	SW4	Baud rate
0	0	1200
0	1	2400
1	0	4800
1	1	9600

DIP switch position 1 enables the user to add the V character after the value and switch position 2 will add the line feed character after the carriage return.

The input voltage range for the logger is 0-5V with a resolution of 19.6mV – 8 bit. **DO NOT EXCEED THIS INPUT VOLTAGE.**

Assembly

Insert the components as shown on the previous page, ensuring the PIC is correctly inserted. Check the board for solder bridges and dry joints before applying power.

Moving on from here

If you wish to learn more about the PIC, there are a number of books on the subject which will assist.

Beginners Guide to the PIC	489-359
PIC Cookbook Vol 1	654-991
PIC Cookbook Vol 2	790-606

The minimum hardware needed to get started is the PIC Start Plus programmer (704-740) which is supplied with its own development environment – MPLAB. From there you could branch out to an ICEPIC In Circuit Emulator which speeds up development time. The software on the disk is in a text format which can be printed from any wordprocessor package or DOS EDIT.

Bluebird Electronics
Suite 2, Townsend Barn
Poulshot, Devizes, Wilts SN10 1SD
Tel +44 (0) 1380 827080
Fax +44 (0) 1380 827082
internet www.bluebird-electronics.co.uk
email info@bluebird-electronics.co.uk

X-ON Electronics

Largest Supplier of Electrical and Electronic Components

Click to view similar products for [bluebird](#) manufacturer:

Other Similar products are found below :

[Bluebird](#)