

## Reflectors for Industrial Sensors

# Sensing ranges overview for top products

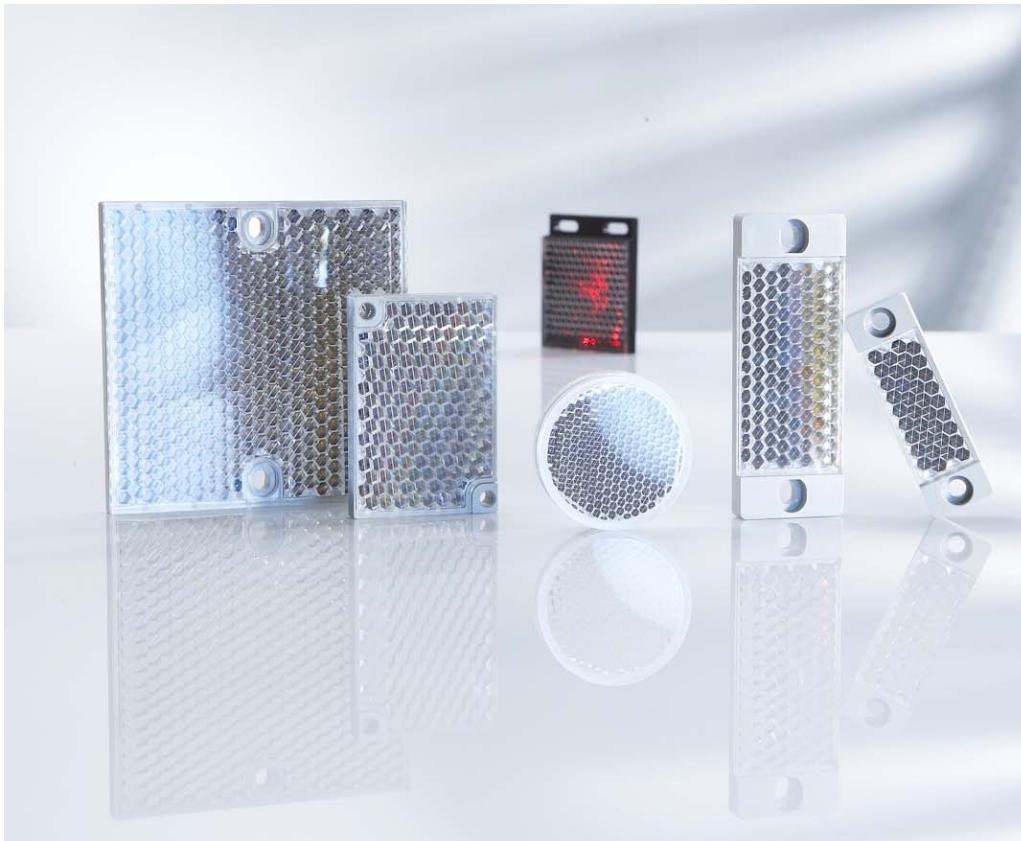

Standard photoelectric retro-reflective sensors, maximum sensing ranges

---

G 6

---

W 4 / W 4 S-3  
W 9-3

---

W 11-2  
W 12-3

---

W 14-2  
W 18-3

---

W 23-2  
W 27-3

---

MH 15

---

V 180-2

---

## Table of contents

Standard reflectors	Page 7
Fine triple reflectors	Page 21
Special reflectors	Page 27
Reflectors for distance sensors	Page 37
Reflective tapes	Page 43
Mounting systems for reflectors	Page 51

Laser photoelectric retro-reflective sensors, maximum sensing ranges

---

WL 100L

---

WL 9L-2

---

WL 12L-2

---

VL 18L

---

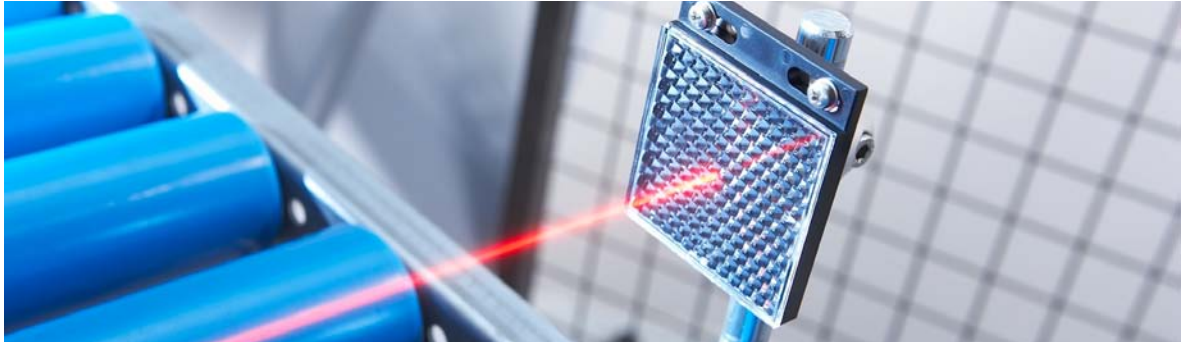

Standard reflectors

Fine triple reflectors

Special reflectors

Reflectors for distance sensors

Reflective tapes

Mounting systems for reflectors

PL22-1/ PL22-2/ PL22-3	PL20A/ PL21A	PL30A/ PL31A	P50-1	PL40A	P250	C110A	PL80A	REFLECTIVE TAPE	
								REF-DG/REF-DG-K	REF-Plus
0,03 m ... 2,7 m 		0,03 m ... 4 m 		0,03 m ... 6 m 		0,03 m ... 7,2 m 		0,06 m ... 1,9 m 	0,06 m ... 2,0 m 
0 m ... 1,4 m/2,2 m 		0 m ... 2,5 m/3,2 m 		0 m ... 3 m/4 m 		0 m ... 4 m/5 m 		0,4 m ... 0,6 m 	0,5 m ... 0,8 m 
0 m ... 3 m/4 m 		0 m ... 5,5 m/6,3 m 		0 m ... 5 m/7 m 		0 m ... 7 m/10 m 		0,3 m ... 1 m/1,5 m 	0,3 m ... 1,2 m/1,8 m 
0 m ... 3 m  0,15 m ... 4,5 m * 		0 m ... 3,5 m/3,8 m  0,15 m ... 6,5 m * 		0 m ... 5 m/6 m  0,15 m ... 14 m * 		0 m ... 6 m/7 m  0,15 m ... 17 m * 		0,06 m ... 1,6 m/1,7 m 	0,06 m ... 1,8 m/2,0 m 
0,1 m ... 4 m/6 m  0,1 m ... 6 m/8 m * 		0,1 m ... 4 m/7 m  0,1 m ... 7,5 m/10 m * 		0,1 m ... 5 m/9 m  0,1 m ... 10 m/15 m * 		0,1 m ... 5 m/15 m  0,1 m ... 12 m/19 m * 		0,3 m ... 4 m/5 m 	0,3 m ... 4,4 m/5,5 m 
0,03 m ... 1,1 m 		0,03 m ... 1,2 m 		0,03 m ... 1,4 m/2,2 m 		0,03 m ... 4 m/5 m 		0,4 m ... 0,7 m 	0,4 m ... 0,8 m 
0,05 m ... 3 m 		0,05 m ... 4,5 m 		0,05 m ... 6 m 		0,05 m ... 7 m 		0,1 m ... 1,4 m 	0,1 m ... 1,6 m 

\* PinPoint variants

PL10F	PL20F	P250F	REFLECTIVE TAPE
			REF-AC1000/ REF-AC1000-56/P41F
0,1 m ... 6,5 m 	0,1 m ... 8,5 m 	0,1 m ... 12 m 	0,1 m ... 11 m 
0,1 m ... 5 m 	0,1 m ... 6 m 	0,15 m ... 7 m 	0,2 m ... 8 m 
0 m ... 6 m 	0 m ... 7,5 m 	0 m ... 12 m 	0 m ... 8 m 
0,1 m ... 25 m 	0,1 m ... 15 m 	0,1 m ... 30 m 	0,1 m ... 15 m 

Sensing range information is intended as a rough guide. For sensing ranges attainable with a specific sensor/reflector combination, see the relevant sensor data sheet or else ask us about this.

# Useful information about reflectors and reflective tapes

- ▶ **Reflectors are an indispensable counterpart for all photoelectric retro-reflective sensors. Together they form a fixed functional unit. Reliable detection of objects can only be guaranteed, even under critical application conditions, if both components are optimally coordinated with one another.**
- ▶ **Sensing range and efficiency of detection of a photoelectric retro-reflective sensor are significantly influenced by the quality and geometrical size of the reflector used.**
- ▶ **The larger the reflector, the greater the operating reserve and the larger the sensor sensing range possible.**

## Standard reflectors vs. reflective tapes

Standard reflectors from SICK differ according to size, geometry and mounting options. The large selection of different types guarantees optimal sensor operation at all times and perfect integration into systems.

Reflective tapes (→ page 43 ff.) are typically used where use of a standard reflector is not possible due to mounting or space restrictions, or if the application requires a large, uninterrupted reflection area. It is important to note however that the sensing range of a photoelectric retro-reflective sensor is significantly reduced compared to a standard reflector of the same size when REF-DG or REF-Plus standard reflective tapes are used.

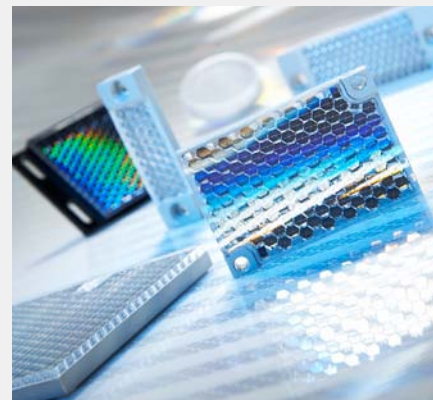

## Reflectors and reflective tapes for laser sensors

Laser photoelectric retro-reflective sensors are particularly characterized by their large sensing ranges and very small light spots. These place special requirements on the reflector however. If the reflector's individual triple elements are too large, erroneous reflections may occur resulting in signal interruptions – particularly if the laser light spot passes over the reflector.

For this reason, SICK provides fine triple reflectors specially for laser photoelectric retro-reflective sensors (page 21 ff.) that have a particularly small triple structure and hence guarantee a stable reflection signal. In the case of reflective tapes, the REF-AC1000 with its uninterrupted microprism structure offers optimal signal stability and sensing range for laser photoelectric retro-reflective sensors. REF-Plus and REF-DG standard reflective tapes on the other hand are not suitable for laser photoelectric sensors due to their honeycomb structure.



## Acid and alkali-proof reflectors

Sensors in the food and pharmaceuticals industry are subject to special requirements. They have to be permanently resistant to daily cleaning cycles with particularly aggressive chemical cleaning agents, high cleaning temperatures and pressures without any damage occurring to the sensor or reflector or impairment to its reflective properties. Stainless steel reflectors and CHEM reflectors by SICK will do justice to these requirements. For details, see pages 28 to 31.



## Polarization

Photoelectric retro-reflective sensors are available with or without polarizing filter. The polarizing filter ensures that even highly-reflective objects in the beam path will be reliably detected. To do this, the light emitted is coded by the sensor's polarizing filter in a certain way. The reflector changes the code of the emitted light in a defined way and sends this back to the sensor. Only if the receiver of the photoelectric retro-reflective sensor receives the light with this modified code it will be interpreted by the sensor as an "unobstructed light path" i.e. "No object in the beam path". If the emitted light is reflected by another reflective object but there is no code, the sensor will register an object in the light path. All SICK reflectors have this code-changing property. The only exceptions are a few reflective tapes. These are referred to explicitly in the data sheets for the relevant tape that follow.

## The right reflector for virtually all applications

Most applications in industrial environments can be catered for using standard plastic reflectors or reflective tapes. Special applications require special sensors and reflectors however. SICK therefore offers a wide range of special solutions:

- Chemically-resistant reflectors
- Stainless steel reflectors
- Heatable reflectors (regulated and unregulated)
- Reflectors for high-temperature use
- Antifog reflectors
- Single-triple glass reflectors
- Dust-resistant and air-rinsed reflector solutions
- Large, premounted reflector plates, plus many more



## Standard reflectors (round and rectangular)

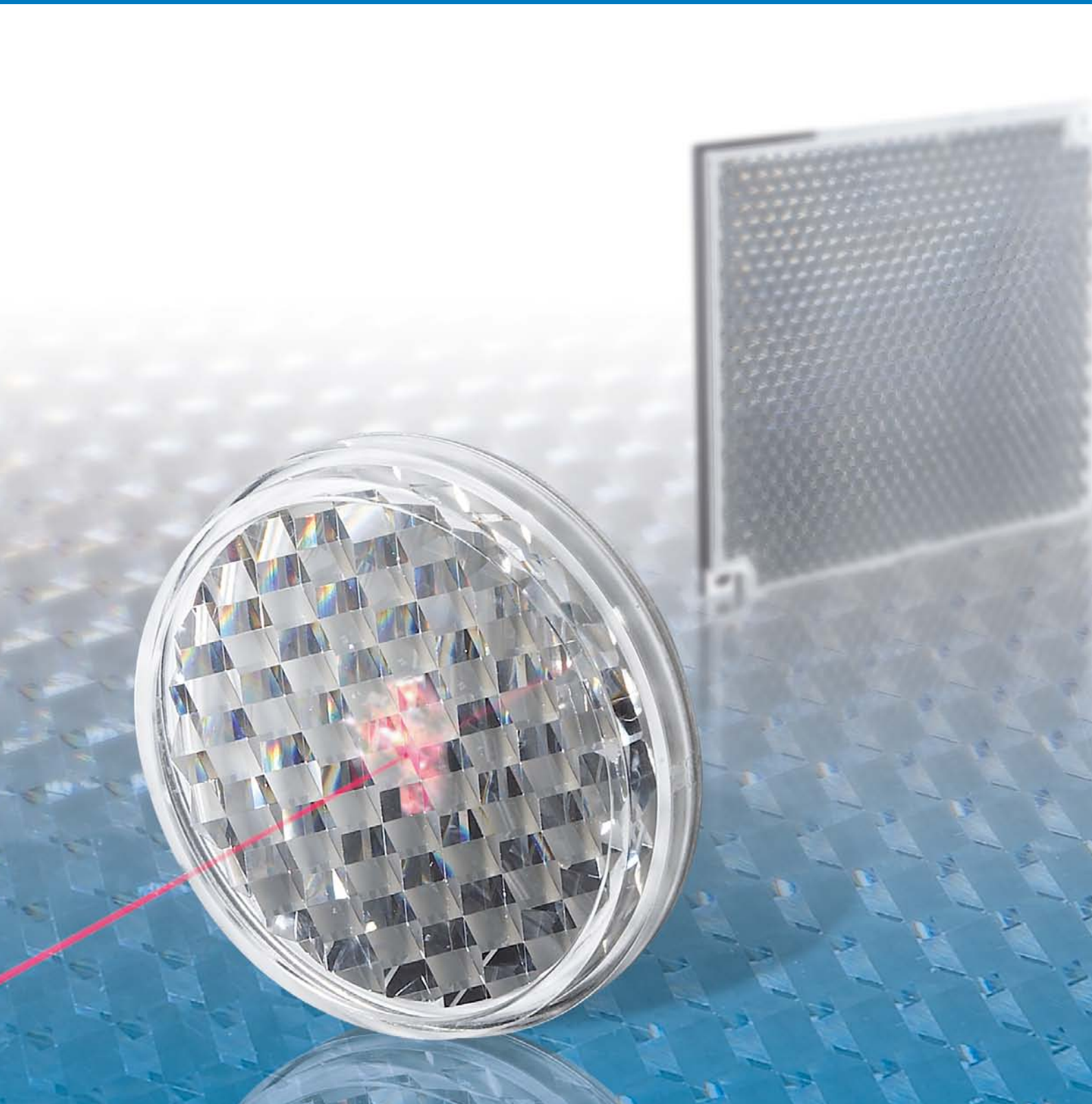

Standard reflectors from SICK differ according to size, geometry and mounting options. The large selection of reflectors in different shapes and sizes guarantees optimal sensor operation at all times and perfect integration into systems.



# STANDARD REFLECTORS



**P32**  
Reflector, rectangular,  
screw connection

Dimensional drawing

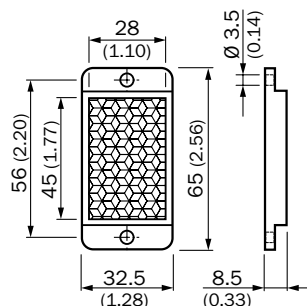

All dimensions in mm (inch)

**Technical data**

Reflection area	28 mm x 45 mm
Material	PMMA/ABS
Temperature	-20 °C ... +65 °C

**Ordering information**

Model name	Part no.
P32	5314001



**P40**  
Reflector, rectangular,  
screw connection

Dimensional drawing

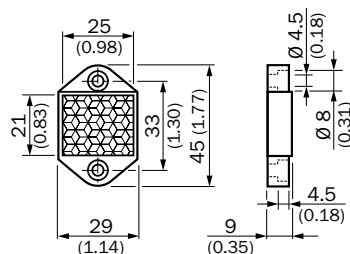

All dimensions in mm (inch)

**Technical data**

Reflection area	21 mm x 25 mm
Material	PMMA/ABS
Temperature	-20 °C ... +65 °C

**Ordering information**

Model name	Part no.
P40	5313923



**P42**  
Reflector, rectangular,  
screw connection

Dimensional drawing

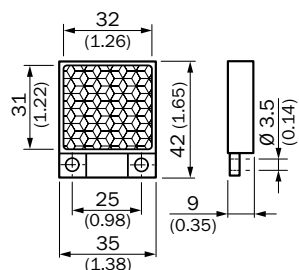

All dimensions in mm (inch)

**Technical data**

Reflection area	31 mm x 32 mm
Material	PMMA/ABS
Temperature	-20 °C ... +65 °C

**Ordering information**

Model name	Part no.
P42	5314825





**P45A**

Reflector, rectangular,  
screw connection

Dimensional drawing

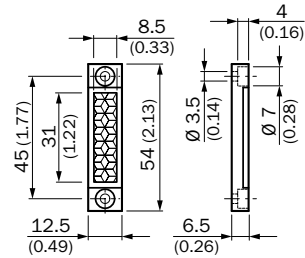

All dimensions in mm (inch)

**Technical data**

Reflection area	8,5 mm x 31 mm
Material	PMMA/ABS
Temperature	-20 °C ... +65 °C

**Ordering information**

Model name	Part no.
P45A	5320027



**PL20A**

Reflector, rectangular,  
screw connection

Dimensional drawing

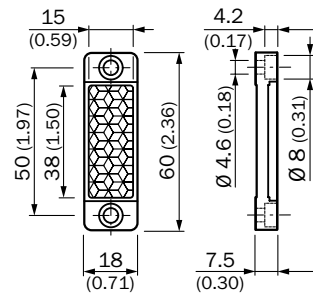

All dimensions in mm (inch)

**Technical data**

Reflection area	15 mm x 38 mm
Material	PMMA/ABS
Temperature	-20 °C ... +65 °C

**Ordering information**

Model name	Part no.
PL20A	1012719



**PL21A**

Reflector, rectangular,  
self-adhesive

Dimensional drawing

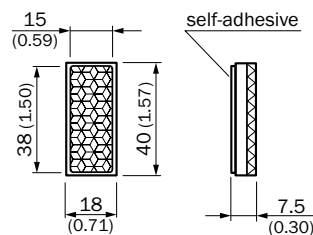

All dimensions in mm (inch)

**Technical data**

Reflection area	15 mm x 38 mm
Material	PMMA/ABS
Temperature	-20 °C ... +65 °C

**Ordering information**

Model name	Part no.
PL21A	1015172



**PL30A**  
Reflector, rectangular,  
screw connection

Dimensional drawing

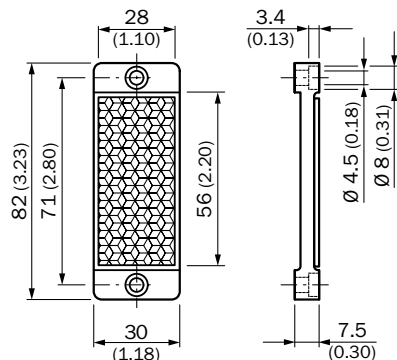

All dimensions in mm (inch)

**Technical data**

Reflection area	28 mm x 56 mm
Material	PMMA/ABS
Temperature	-20 °C ... +65 °C

**Ordering information**

Model name	Part no.
PL30A	1002314



**PL31A**  
Reflector, rectangular,  
self-adhesive

Dimensional drawing

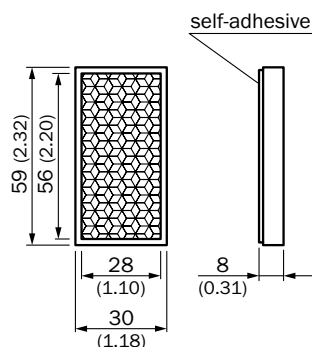

All dimensions in mm (inch)

**Technical data**

Reflection area	28 mm x 56 mm
Material	PMMA/ABS
Temperature	-20 °C ... +65 °C

**Ordering information**

Model name	Part no.
PL31A	1002315



**PL40A**  
Reflector, rectangular,  
screw connection

Dimensional drawing

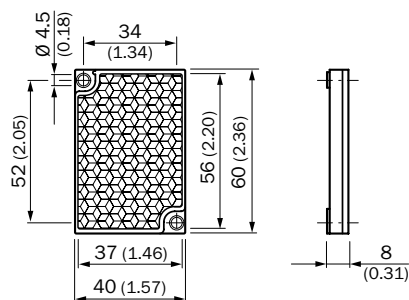

All dimensions in mm (inch)

**Technical data**

Reflection area	37 mm x 56 mm
Material	PMMA/ABS
Temperature	-20 °C ... +65 °C

**Ordering information**

Model name	Part no.
PL40A	1012720



**PL40B**

Reflector, rectangular, screw connection

Dimensional drawing

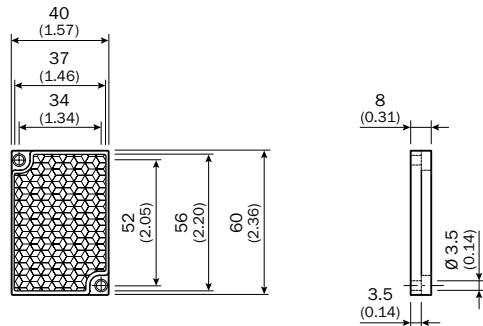

All dimensions in mm (inch)

**Technical data**

Reflection area	37 mm x 56 mm
Material	PMMA/ABS
Temperature	-20 °C ... +65 °C

**Ordering information**

Model name	Part no.
PL40B	5320134



**PL50A**

Reflector, rectangular, screw connection

Dimensional drawing

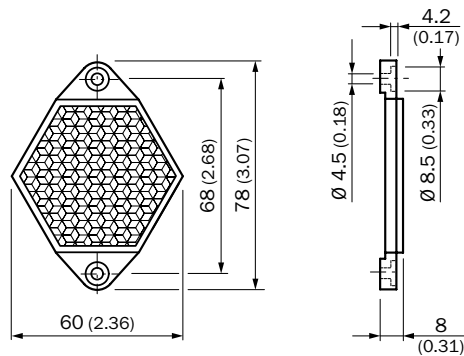

All dimensions in mm (inch)

**Technical data**

Reflection area	WS* 48 mm
Material	PMMA/ABS
Temperature	-20 °C ... +65 °C

**Ordering information**

Model name	Part no.
PL50A	1000132

\* WS = wrench size



**PL51A**

Reflector, rectangular, self-adhesive

Dimensional drawing

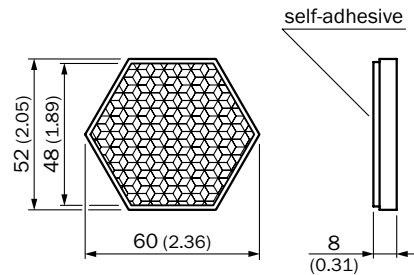

All dimensions in mm (inch)

**Technical data**

Reflection area	WS* 48 mm
Material	PMMA/ABS
Temperature	-20 °C ... +65 °C

**Ordering information**

Model name	Part no.
PL51A	1001628

\* WS = wrench size





**PL81**  
Reflector, rectangular,  
self-adhesive

Dimensional drawing

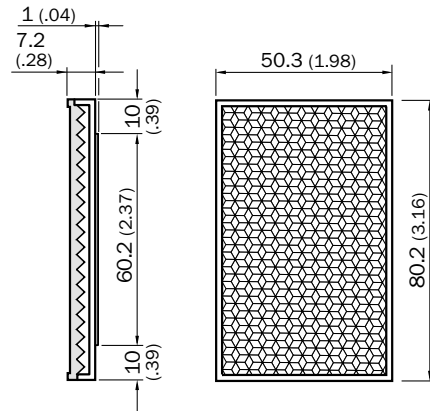

Technical data

Reflection area	45 mm x 75 mm
Material	PMMA/ABS
Temperature	-20 °C ... +65 °C

Ordering information

Model name	Part no.
PL81	5322795



**PL100**  
Reflector, rectangular,  
screw connection

Dimensional drawing

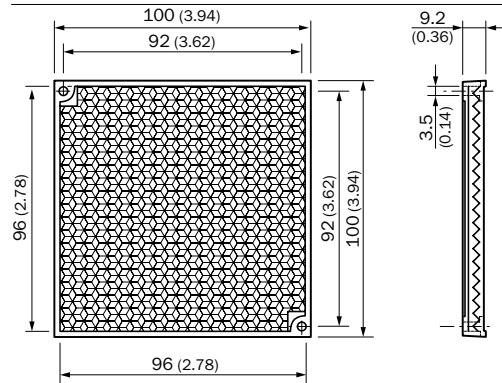

Technical data

Reflection area	96 mm x 96 mm
Material	PMMA/ABS
Temperature	-20 °C ... +65 °C

Ordering information

Model name	Part no.
PL100	5321625

All dimensions in mm (inch)

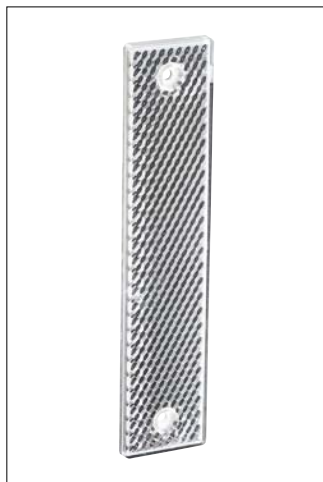

**PL180E01**  
Reflector, rectangular,  
screw connection

Dimensional drawing

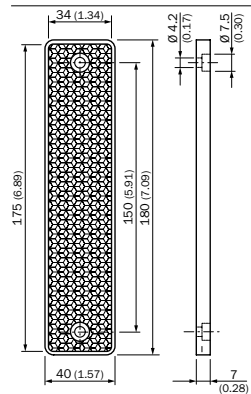

Technical data

Reflection area	34 mm x 175 mm
Material	PMMA/ABS
Temperature	-20 °C ... +65 °C

Ordering information

Model name	Part no.
PL180E01	1013289

All dimensions in mm (inch)



## PL150

Reflector, rectangular, self-adhesive

### Dimensional drawing

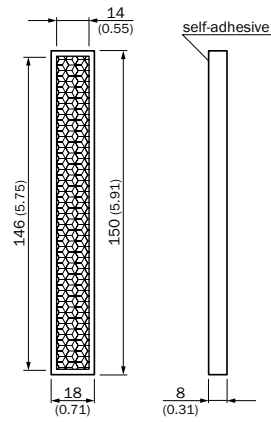

All dimensions in mm (inch)

### Technical data

Reflection area	14 mm x 146 mm
Material	PMMA/ABS
Temperature	-20 °C ... +65 °C

### Ordering information

Model name	Part no.
PL150	5315548



**PL22-1**

Reflector, round,  
pluggable

Dimensional drawing

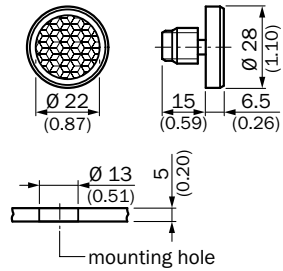

All dimensions in mm (inch)

**Technical data**

Reflection area	Ø 22 mm
Material	PMMA/ABS
Temperature	-20 °C ... +65 °C

**Ordering information**

Model name	Part no.
PL22-1	1003546



**PL22-2**

Reflector, round,  
self-adhesive

Dimensional drawing

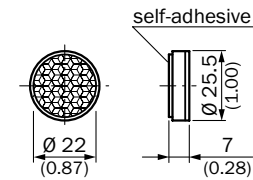

All dimensions in mm (inch)

**Technical data**

Reflection area	Ø 22 mm
Material	PMMA/ABS
Temperature	-20 °C ... +65 °C

**Ordering information**

Model name	Part no.
PL22-2	1003621



**PL22-3**

Reflector, round,  
pluggable for metal plates

Dimensional drawing

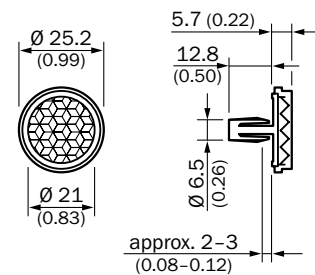

All dimensions in mm (inch)

**Technical data**

Reflection area	Ø 21 mm
Material	PMMA/ABS
Temperature	-20 °C ... +65 °C

**Ordering information**

Model name	Part no.
PL22-3	1004488



**P25**  
Reflector, round,  
M4 x 8 threaded bolts

Dimensional drawing

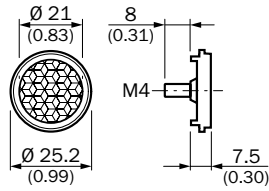

All dimensions in mm (inch)

### Technical data

Reflection area	Ø 21 mm
Material	PMMA/ABS
Temperature	-20 °C ... +65 °C

### Ordering information

Model name	Part no.
P25	5315172



**P25-2**  
Reflector, round,  
pluggable

Dimensional drawing

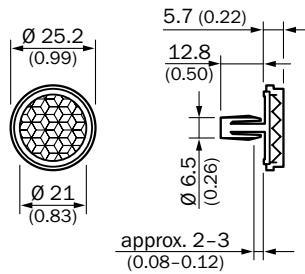

All dimensions in mm (inch)

### Technical data

Reflection area	Ø 21 mm
Material	PMMA/ABS
Temperature	-20 °C ... +65 °C

### Ordering information

Model name	Part no.
P25-2	5318969



**P34**  
Reflector, round,  
planar

Dimensional drawing

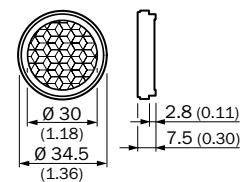

All dimensions in mm (inch)

### Technical data

Reflection area	Ø 30 mm
Material	PMMA/ABS
Temperature	-20 °C ... +65 °C

### Ordering information

Model name	Part no.
P34	5313922





**PL34-1**

Reflector, round,  
pluggable

Dimensional drawing

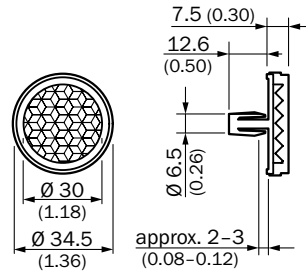

All dimensions in mm (inch)

**Technical data**

Reflection area	Ø 30 mm
Material	PMMA/ABS
Temperature	-20 °C ... +65 °C

**Ordering information**

Model name	Part no.
PL34-1	5322257



**P50-1**

Reflector, round,  
M5 x 9 threaded bolts

Dimensional drawing

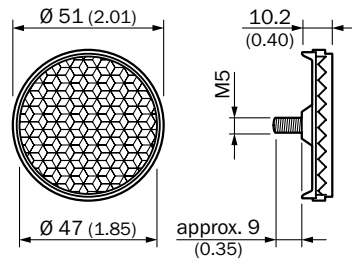

All dimensions in mm (inch)

**Technical data**

Reflection area	Ø 47 mm
Material	PMMA/ABS
Temperature	-20 °C ... +65 °C

**Ordering information**

Model name	Part no.
P50-1	5322673



**P55**

Reflector, round,  
screw connection

Dimensional drawing

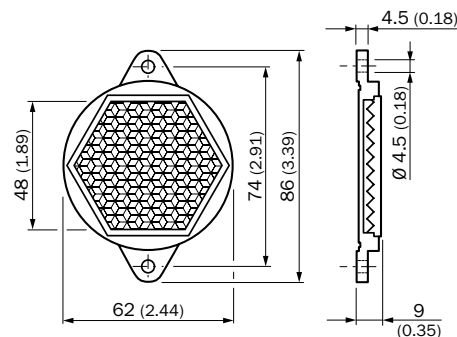

All dimensions in mm (inch)

**Technical data**

Reflection area	WS* 48 mm
Material	PMMA/ABS
Temperature	-20 °C ... +65 °C

**Ordering information**

Model name	Part no.
P55	5318680

\* WS = wrench size



**C42-1**  
Reflector, round,  
pluggable

Dimensional drawing

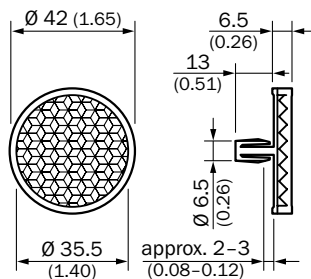

All dimensions in mm (inch)

**Technical data**

Reflection area	$\varnothing 35,5$ mm
Material	PMMA/ABS
Temperature	-20 °C ... +65 °C

**Ordering information**

Model name	Part no.
C42-1	5313506



**C42-2**  
Reflector, round,  
M5 x 9 threaded bolts

Dimensional drawing

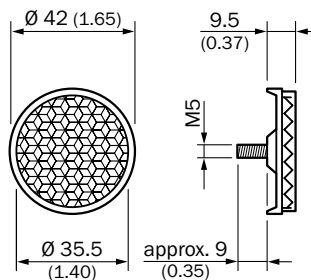

All dimensions in mm (inch)

**Technical data**

Reflection area	$\varnothing 35,5$ mm
Material	PMMA/ABS
Temperature	-20 °C ... +65 °C

**Ordering information**

Model name	Part no.
C42-2	5324281



**C64A**  
Reflector, round,  
screw connection

Dimensional drawing

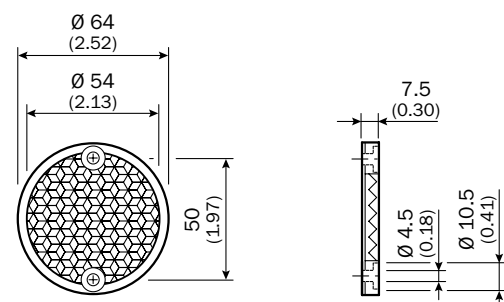

All dimensions in mm (inch)

**Technical data**

Reflection area	54 mm
Material	PMMA/ABS
Temperature	-20 °C ... +65 °C

**Ordering information**

Model name	Part no.
C64A	5325185



**C110A**

Reflector, round,  
screw connection

Dimensional drawing

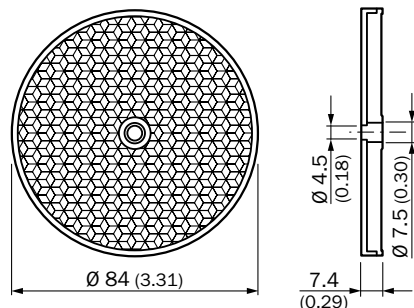

All dimensions in mm (inch)

**Technical data**

Reflection area	Ø 80 mm
Material	PMMA/ABS
Temperature	-20 °C ... +65 °C

**Ordering information**

Model name	Part no.
C110A	5304549

Standard reflectors

Fine triple reflectors

Special reflectors

Reflectors for distance sensors

Reflective tapes

Mounting systems for reflectors

Fine triple reflectors

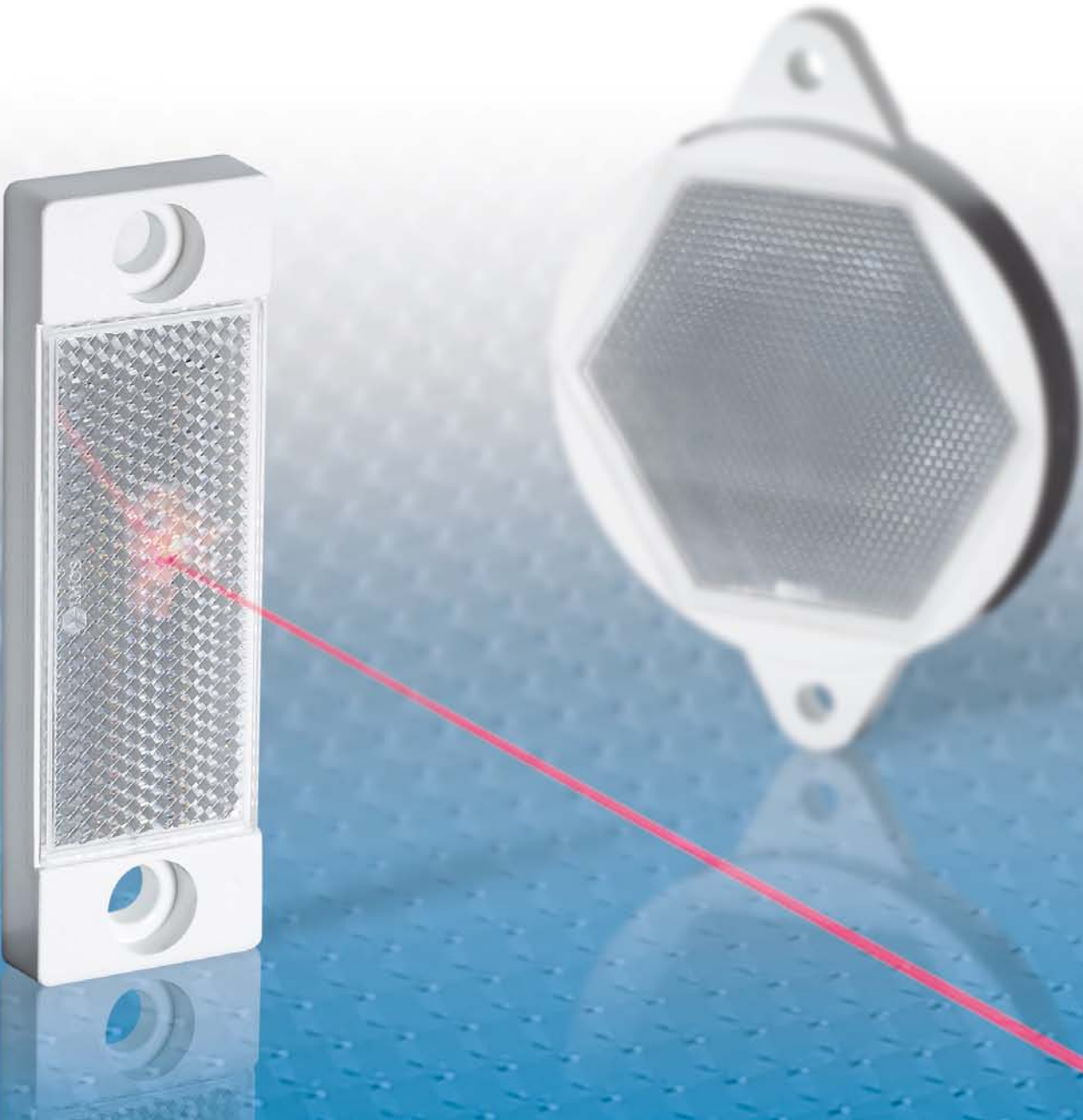

Fine triple reflectors are specially developed for use with laser photoelectric retro-reflective sensors. Their particularly small reflex triple structure enables the small light spot to be beamed across several triples simultaneously at all times. A stable reflection signal for the sensor is thereby guaranteed even when the light spot passes over the reflector. Due to their homogeneous light reflection properties, Fine triple reflectors are also suitable for use with photoelectric sensors for detecting transparent materials.

# SICK

## FINE TRIPLE REFLECTORS



## PL10F

Reflector, fine triple, screw connection, suitable for laser sensors

Dimensional drawing

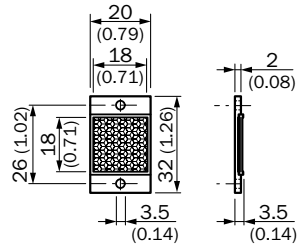

All dimensions in mm (inch)

### Technical data

Reflection area	18 mm x 18 mm
Material	PMMA/ABS
Temperature	-20 °C ... +65 °C

### Ordering information

Model name	Part no.
PL10F	5311210

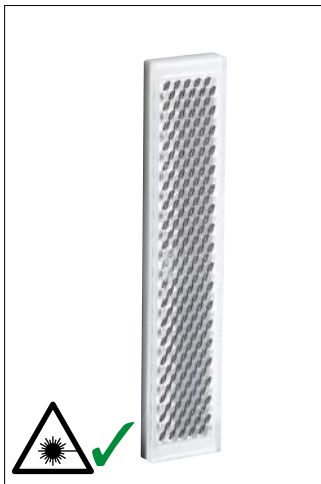

## PL15F

Reflector, fine triple, planar, suitable for laser sensors

Dimensional drawing

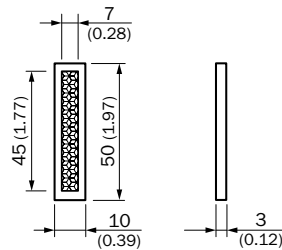

All dimensions in mm (inch)

### Technical data

Reflection area	7 mm x 45 mm
Material	PMMA/ABS
Temperature	-20 °C ... +65 °C

### Ordering information

Model name	Part no.
PL15F	5313849



## PL18F

Reflector, fine triple, self-adhesive, suitable for laser sensors

Dimensional drawing

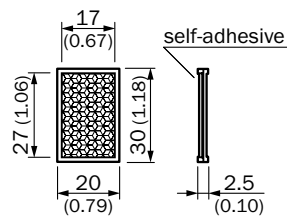

All dimensions in mm (inch)

### Technical data

Reflection area	17 mm x 27 mm
Material	PMMA/ABS
Temperature	-20 °C ... +65 °C

### Ordering information

Model name	Part no.
PL18F	5319994



**PL20F**

Reflector, fine triple, screw connection, suitable for laser sensors

Dimensional drawing

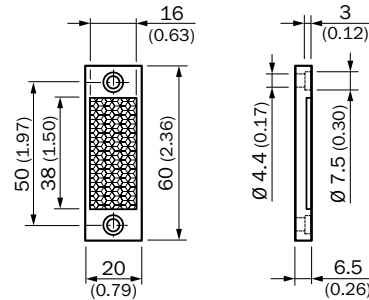

All dimensions in mm (inch)

**Technical data**

Reflection area	16 mm x 38 mm
Material	PMMA/ABS
Temperature	-20 °C ... +65 °C

**Ordering information**

Model name	Part no.
PL20F	5308844



**PL30F**

Reflector, fine triple, screw connection, suitable for laser sensors

Dimensional drawing

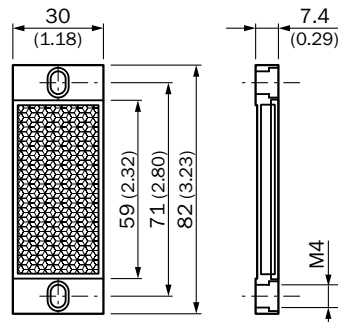

All dimensions in mm (inch)

**Technical data**

Reflection area	28 mm x 56 mm
Material	PMMA/ABS
Temperature	-20 °C ... +65 °C

**Ordering information**

Model name	Part no.
PL30F	5326523



**P25F-1**

Reflector, fine triple, self-adhesive, suitable for laser sensors

Dimensional drawing

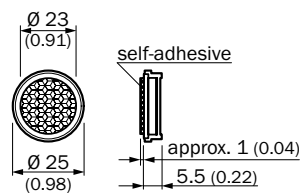

All dimensions in mm (inch)

**Technical data**

Reflection area	Ø 23 mm
Material	PMMA/ABS
Temperature	-20 °C ... +65 °C

**Ordering information**

Model name	Part no.
P25F-1	5319385

Standard reflectors

Fine triple reflectors

Special reflectors

Reflectors for distance sensors

Reflective tapes

Mounting systems for reflectors



## P41F

Reflector with REF-AC1000 microprism reflective tape, suitable for laser sensors, alignment note: see page 47

### Dimensional drawing

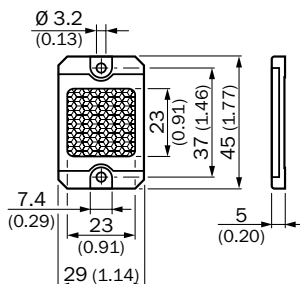

All dimensions in mm (inch)

### Technical data

Reflection area	23 mm x 23 mm
Material	PMMA/ABS
Temperature	-20 °C ... +60 °C

### Ordering information

Model name	Part no.
P41F	5315128



## P55F

Reflector, fine triple, screw connection, suitable for laser sensors

### Dimensional drawing

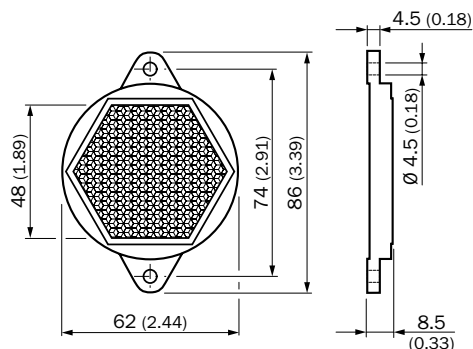

All dimensions in mm (inch)

### Technical data

Reflection area	WS* 48 mm
Material	PMMA/ABS
Temperature	-20 °C ... +65 °C

### Ordering information

Model name	Part no.
P55F	5313924

\* WS = wrench size



## P250F

Reflector, fine triple, screw connection, suitable for laser sensors

### Dimensional drawing

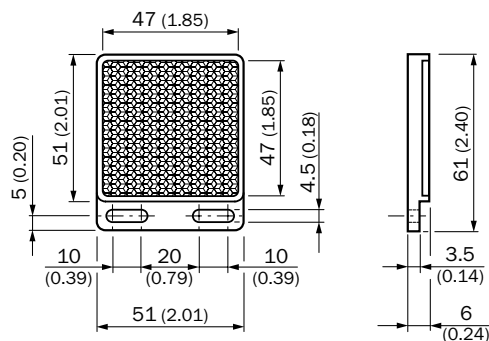

All dimensions in mm (inch)

### Technical data

Reflection area	47 mm x 47 mm
Material	PMMA/ABS
Temperature	-20 °C ... +65 °C

### Ordering information

Model name	Part no.
P250F	5308843





## PL81-1F

Reflector, fine triple, screw connection, suitable for laser sensors

### Dimensional drawing

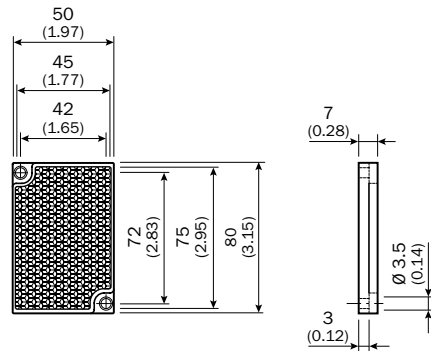

All dimensions in mm (inch)

### Technical data

Reflection area	45 mm x 75 mm
Material	PMMA/ABS
Temperature	-20 °C ... +65 °C

### Ordering information

Model name	Part no.
PL81-1F	5325060

Standard reflectors

Fine triple reflectors

Special reflectors

Reflectors for distance sensors

Reflective tapes

Mounting systems for reflectors

## Special reflectors

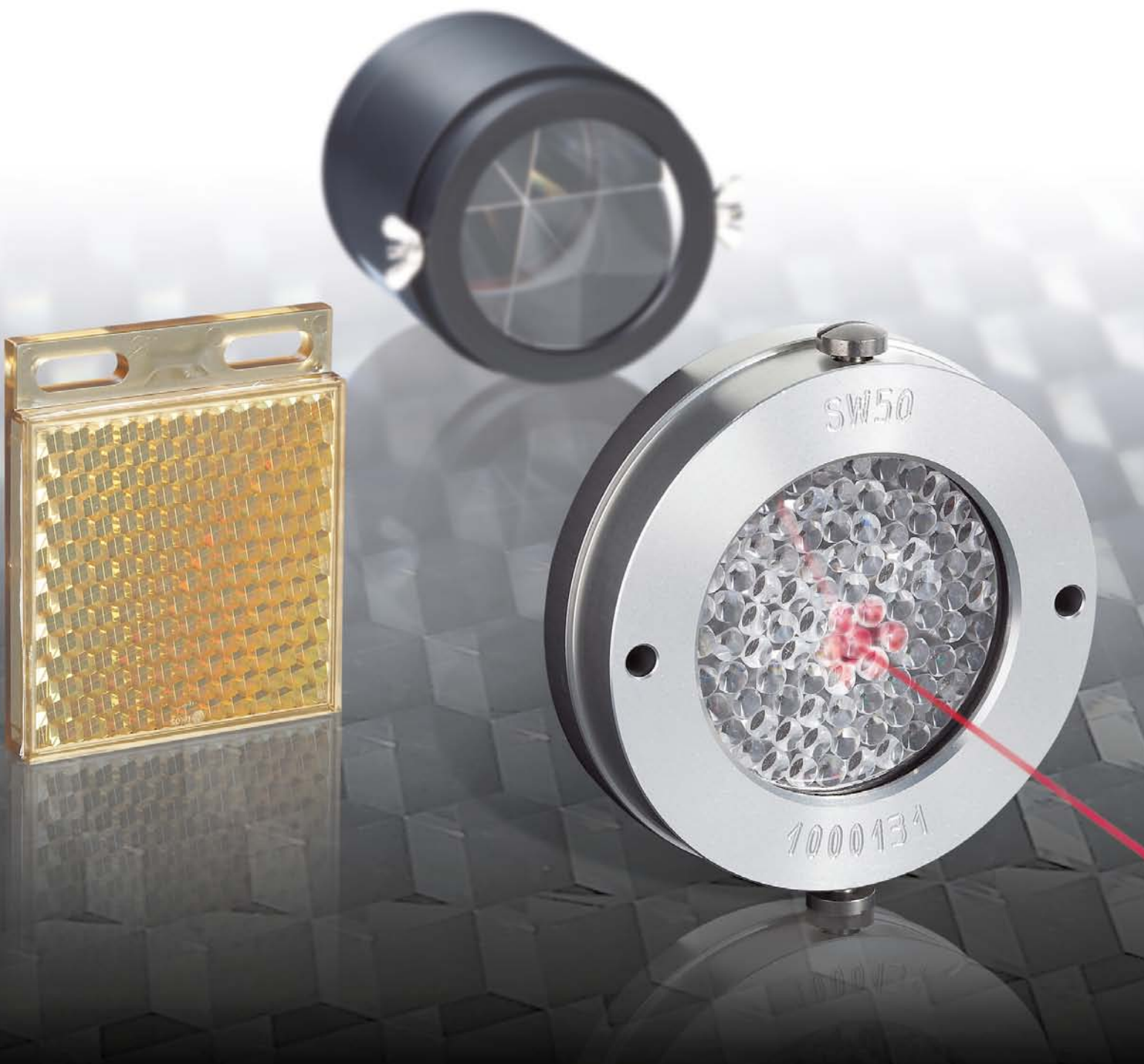

**Special application conditions require customized sensors – and suitable reflectors of course. For this reason, SICK offers a wide range of special reflectors that do justice to the most varied requirements. These include stainless steel reflectors, chemically resistant reflectors, high-temperature reflectors, dust-resistant solutions – and many more.**

# SICK

## SPECIAL REFLECTORS



## PLV14-A

Stainless steel reflector,  
Washdown Design, chemically resistant, screw connection,  
suitable for laser sensors, alignment note: see page 47

### Dimensional drawing

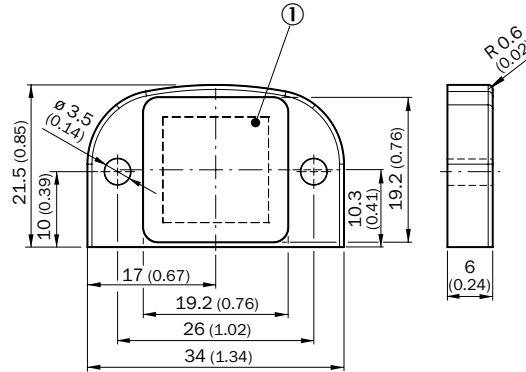

### Technical data

Reflection area	14 mm x 14 mm
Material	Stainless steel
Temperature	-20 °C ... +60 °C
Enclosure rating	IP 67, IP 69K

### Ordering information

Model name	Part no.
PLV14-A	2063405



## PLH25-M12

Stainless steel reflector,  
Hygiene design, chemically resistant, M12 adapter threads,  
suitable for laser sensors, alignment note: see page 47

### Dimensional drawing

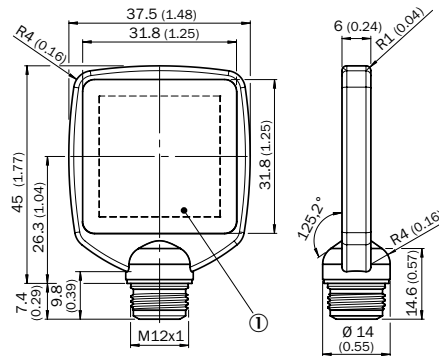

### Technical data

Reflection area	25 mm x 25 mm
Material	Stainless steel
Temperature	-20 °C ... +60 °C
Enclosure rating	IP 67, IP 69K

### Ordering information

Model name	Part no.
PLH25-M12	2063403



## PLH25-D12

Stainless steel reflector,  
Hygiene design, chemically resistant, D12 adapter shaft,  
suitable for laser sensors, alignment note: see page 47

### Dimensional drawing

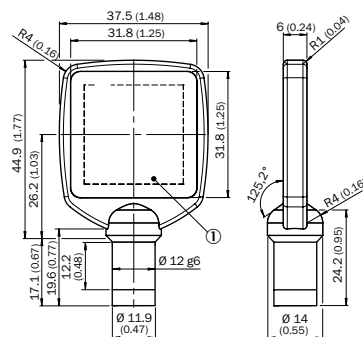

### Technical data

Reflection area	25 mm x 25 mm
Material	Stainless steel
Temperature	-20 °C ... +60 °C
Enclosure rating	IP 67, IP 69K

### Ordering information

Model name	Part no.
PLH25-D12	2063404



**PL10F-CHEM**

Reflector, fine triple, chemically resistant (see page 31), screw connection, suitable for laser sensors

Dimensional drawing

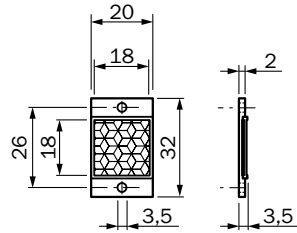

Alle Maße in mm

**Technical data**

Reflection area	18 mm x 18 mm
Material	Plastic
Temperature	-20 °C ... +140 °C
Enclosure rating	IP 67, IP 69K

**Ordering information**

Model name	Part no.
PL10F-CHEM	5321636

Standard reflectors

Fine triple reflectors



**PL20CHEM**

Reflector, chemically resistant (see page 31), screw connection

Dimensional drawing

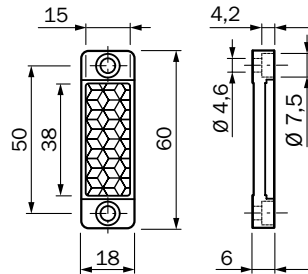

Alle Maße in mm

**Technical data**

Reflection area	15 mm x 38 mm
Material	Plastic
Temperature	-20 °C ... +140 °C
Enclosure rating	IP 67, IP 69K

**Ordering information**

Model name	Part no.
PL20CHEM	5321089

Special reflectors

Reflectors for distance sensors



**PL20F-CHEM**

Reflector, fine triple, chemically resistant (see page 31), screw connection, suitable for laser sensors

Dimensional drawing

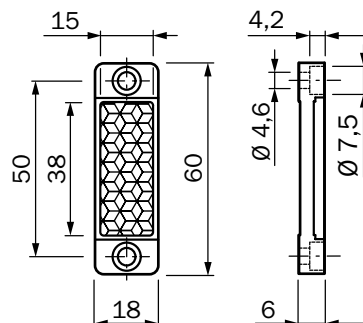

Alle Maße in mm

**Technical data**

Reflection area	16 mm x 38 mm
Material	Plastic
Temperature	-20 °C ... +140 °C
Enclosure rating	IP 67, IP 69K

**Ordering information**

Model name	Part no.
PL20F-CHEM	5326089

Reflective tapes

Mounting systems for reflectors



## PL40B-CHEM

Reflector, chemically resistant (see page 31), screw connection

### Dimensional drawing

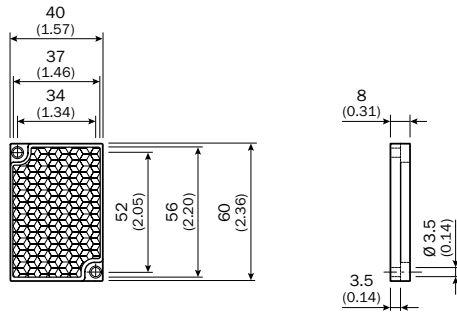

All dimensions in mm (inch)

### Technical data

Reflection area	37 mm x 56 mm
Material	Plastic
Temperature	-20 °C ... +140 °C
Enclosure rating	IP 67, IP 69K

### Ordering information

Model name	Part no.
PL40B-CHEM	5326088



## P250CHEM

Reflector, chemically resistant (see page 31), screw connection

### Dimensional drawing

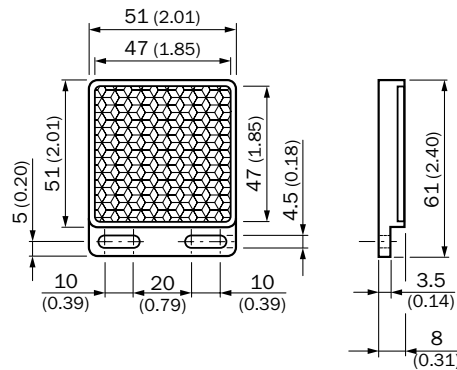

### Technische Daten

Reflection area	47 mm x 47 mm
Material	Plastic
Temperature	-20 °C ... +140 °C
Enclosure rating	IP 67, IP 69K

### Ordering information

Model name	Part no.
P250CHEM	5321097

**PxxxCHEM – Assessment of chemical stress by TÜV Rheinland (Rhineland technical testing authority)**

Liquid tested	Substance group/	Assessment after (composition, color)		
		1 day	7 days	14 days
Acetaldehyde	Aldehydes	0	0	0
Acetone	Ketones	1 (softening of surface)	1 (softening of surface)	1 (softening of surface)
Formic acid	Organic acids	0	0	0
Benzene	Aromat. hydrocarbon	0	0	1 (opacity)
1,3-Butanediol	Polyalcohols	0	0	0
Butylamine	Amines	0	0	0
Chlorobenzene	Chlor., aromat. hydrocarbon	0	0	0
Chloroform	CHC	0	0	0
Chlorosulfonic acid	Acid chlorides	0	0	0
Diesel fuel	Fuels	0	0	0
Diethyl ether	Ether	0	0	0
Dimethyl-formamide	Amides	0	0	0
Dimethyl sulfate	Ester	0	0	0
Glacial acetic acid	Organic acids	0	0	1 (slight fissures)
Acetic acid 10 %	Organic acids	0	0	0
Ethanol	Alcohols	0	0	1 (slight color change)
Ethylene glycol	Polyalcohols	0	0	0
Formaldehyde 37 %	Aldehydes	0	0	0
Heating oil EL	Fuels	0	0	0
Isopropanol	Alcohols	0	0	0
Kerosene	Fuels	0	0	0
m-Cresol	Phenols	0	0	0
Methanol	Alcohols	0	0	1 (opacity)
n-Heptane	Hydrocarbon	0	0	0
Sodium hydroxide 10 %	Alkalis	0	0	0
Salt acid 20 %	Inorganic acids	0	0	0
Sulfuric acid 98 %	Inorganic acids	0	0	0
1, 1, 2, 2 Tetrachloroethane	Chlorinated hydrocarbon	0	0	0
Tetrachloro-methane	Chlorinated hydrocarbon	0	0	0
Toluol	Aromat. hydrocarbon	0	0	0
Hydrogen peroxide (H <sub>2</sub> O <sub>2</sub> ), 10%ig		0	0	0
Cleaning agent Medicine <sup>a</sup>		0	0	0
Cleaning agent food <sup>b</sup>		0	0	0

0 = no change  
 1 = slight change (description required)  
 2 = significant change (description required)  
 a = Lysoformin® 3000 (contents: glyoxal, glutaral, didecylidimethylammonium chloride)  
 b = Bio Tec detergent (contents: alkylbenzene sulfonate, alkyl ether sulfate)

**Measured values were taken from the inspection report by TÜV Rheinland (Rhineland technical testing authority) (Test no. 620/ 434628)**

**PxxxCHEM – Resistant to ECOLAB cleaning agent**

**Implementation:**

- Immersion of the CHEM reflectors in various cleaning solution and concentrates
- Temperature: +60 °C or +80 °C
- Duration: 2 weeks
- After 2 weeks, the reflectors are rinsed with DI water and optically and gravimetrically assessed.

Product/concentration	T [ °C ]	Suitability
P3-cosa CIP 72	60	+
P3-cosa CIP 77	80	+
P3-cosa CIP 90	80	+
P3-cosa CIP 92	80	+
P3-cosa CIP 95	80	+
P3-cosa PUR 80	80	+
P3-cosa PUR 83	80	+
P3-cosa PUR 84	80	+
P3-cosa PUR 85	80	+
P3-cosa PUR 88	80	+
P3-cosa FOAM 40	80	+
P3-cosa DES	80	+
P3-cosa FLUX 22	80	+
P3-cosa FLUX 33	80	+
P3-cosa FLUX 44	80	+
P3-cosa FLUX 55*	80	0

+ = suitable  
 0 = suitable in certain conditions  
 - = unsuitable  
 \* = contains nitric acid

**PxxxCHEM – remission**

Compared with standard reflectors of the same design, PxxxCHEM reflectors exhibit a remission of 50 to 70 %.

Example:

P250 = 100 %,  
 P250CHEM = 50 ... 70 %, dependent on the photoelectric sensor used.

**Note:**

Information on this page is valid for the CHEM reflectors on pages 29 and 30.

Standard reflectors

Fine triple reflectors

Special reflectors

Reflectors for distance sensors

Reflective tapes

Mounting systems for reflectors



## PL40A Antifog

Reflector, antifog, for prevention of moisture fogging on the reflection area, screw connection

Dimensional drawing

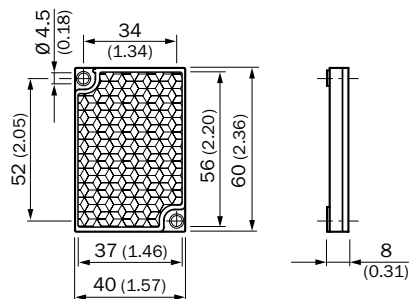

All dimensions in mm (inch)

### Technical data

Reflection area	37 mm x 56 mm
Material	PMMA/ABS
Temperature	-20 °C ... +65 °C

### Ordering information

Model name	Part no.
PL40A Antifog	5322011



## PL50HS/HK

Reflector, heated, screw connection

Dimensional drawing

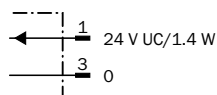
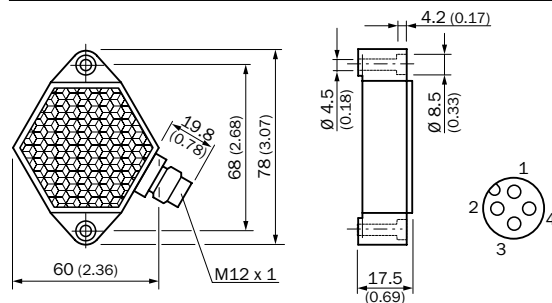

All dimensions in mm (inch)

### Technical data

Reflection area	WS* 48 mm
Material	PMMA/ABS
Temperature	-20 °C ... +65 °C

### Ordering information

Model name	Part no.
PL50HS <sup>1)</sup>	1009871
PL50HK <sup>2)</sup>	1011545

\* WS = wrench size

<sup>1)</sup> Controlled heated, Heater on:  
T < 15 °C

<sup>2)</sup> Permanently heated.



## P250H

High-temperature reflector, screw connection

Dimensional drawing

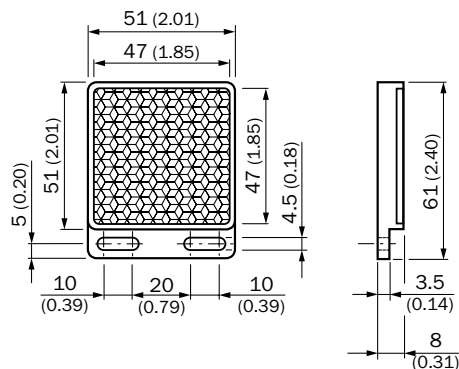

### Technical data

Reflection area	47 mm x 47 mm
Material	HOT Thermoplast
Temperature	-20 °C ... +110 °C

### Ordering information

Model name	Part no.
P250H	5315124



## Technical data

Reflection area	Ø 50 mm
Material	Aluminium (anodized)/ Borosilikatglass
Temperature	Max. +300 °C

## Ordering information

Model name	Part no.
SW50	1000131



### SW50

High-temperature reflector,  
glass, screw connection

Dimensional drawing

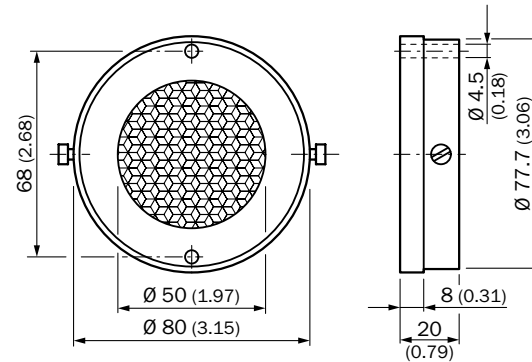

All dimensions in mm (inch)

## Technical data

Reflection area	Ø 60 mm
Material	Aluminium (anodized)/glass
Temperature	Max. +300 °C

## Ordering information

Model name	Part no.
OP61-00	1002627



### OP61-00

Single-triple glass reflector for high-temperature  
applications, screw connection

Dimensional drawing

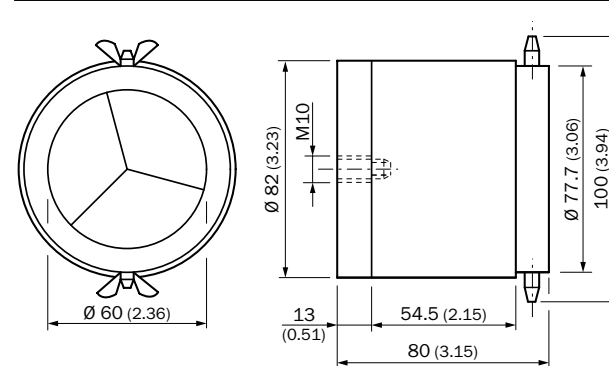

All dimensions in mm (inch)

## Technical data

Reflection area	Ø 60 mm
Material	Aluminium (anodized)/glass
Temperature	-20 °C ... +65 °C

## Ordering information

Model name	Part no.
OP60-00 <sup>1)</sup>	1000141
OP60-20 <sup>2)</sup>	1000136

<sup>1)</sup> Focus = infinite

<sup>2)</sup> Focus = 20 m.



### OP60-xx

Single-triple glass reflector for very high sensing  
ranges, screw connection

Dimensional drawing

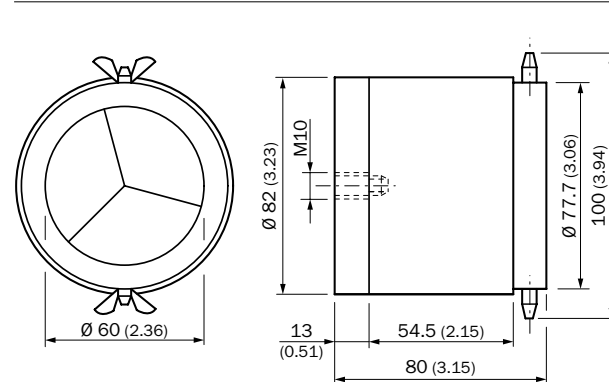

All dimensions in mm (inch)



## PL53A

Reflector, oil-proof, solvent-resistant, screw connection

Dimensional drawing

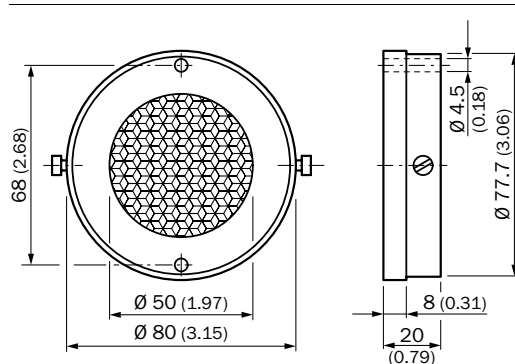

All dimensions in mm (inch)

### Technical data

Reflection area	Ø 50 mm
Material	Aluminium (anodized)/ Borosilikatglass
Temperature	-20 °C ... +65 °C

### Ordering information

Model name	Part no.
PL53A	1000382



## FLV-PL50

Adapter flange for SST DO 80-xxx dust protection tubes and SLV-PL50 rinse air adapter, for PL50A reflector (page 11)

Dimensional drawing

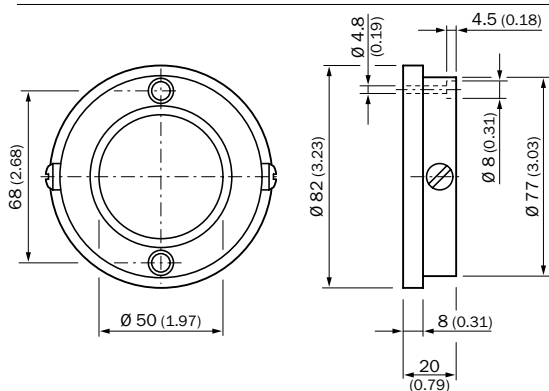

All dimensions in mm (inch)

### Technical data

Material	Aluminium (anodized)
----------	----------------------

### Ordering information

Model name	Part no.
FLV-PL50	1000130



## SST DO 80-xxx

Dust protection tube, accessory for FLV-PL50, SW50, OP60(-20), OP61, SLV-PL50

Dimensional drawing

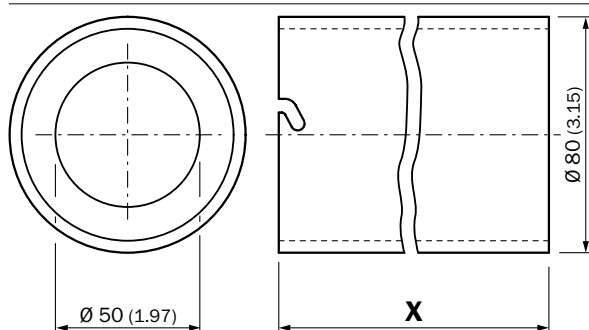

All dimensions in mm (inch)

### Technical data

Material	Aluminium (anodized)
----------	----------------------

### Ordering information

Model name	Part no.
SST DO 80-090 <sup>1)</sup>	1000252
SST DO 80-184 <sup>2)</sup>	1000134

<sup>1)</sup> Length x = 90 mm.

<sup>2)</sup> Length x = 184 mm.



## SLV-PL50

Rinse air adapter for dust protection tubes, for FLV-PL50, PL53A, SW50, OP60(-20), OP61

### Dimensional drawing

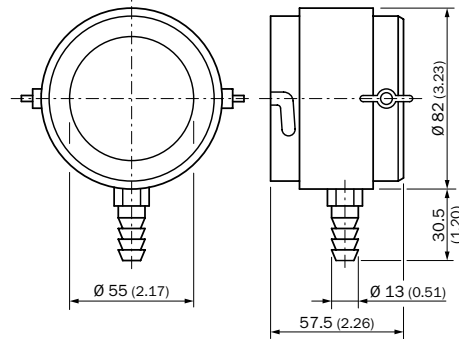

All dimensions in mm (inch)

### Technical data

<b>Material</b>	Aluminium (anodized)
-----------------	----------------------

### Ordering information

Model name	Part no.
SLV-PL50	1000309

### Operating example of reflector with rinse air adapter and dust protection tube

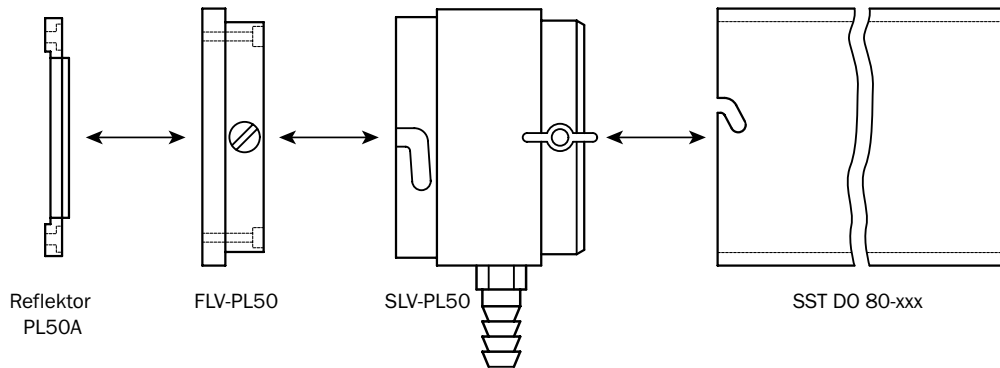

# Reflectors for distance sensors

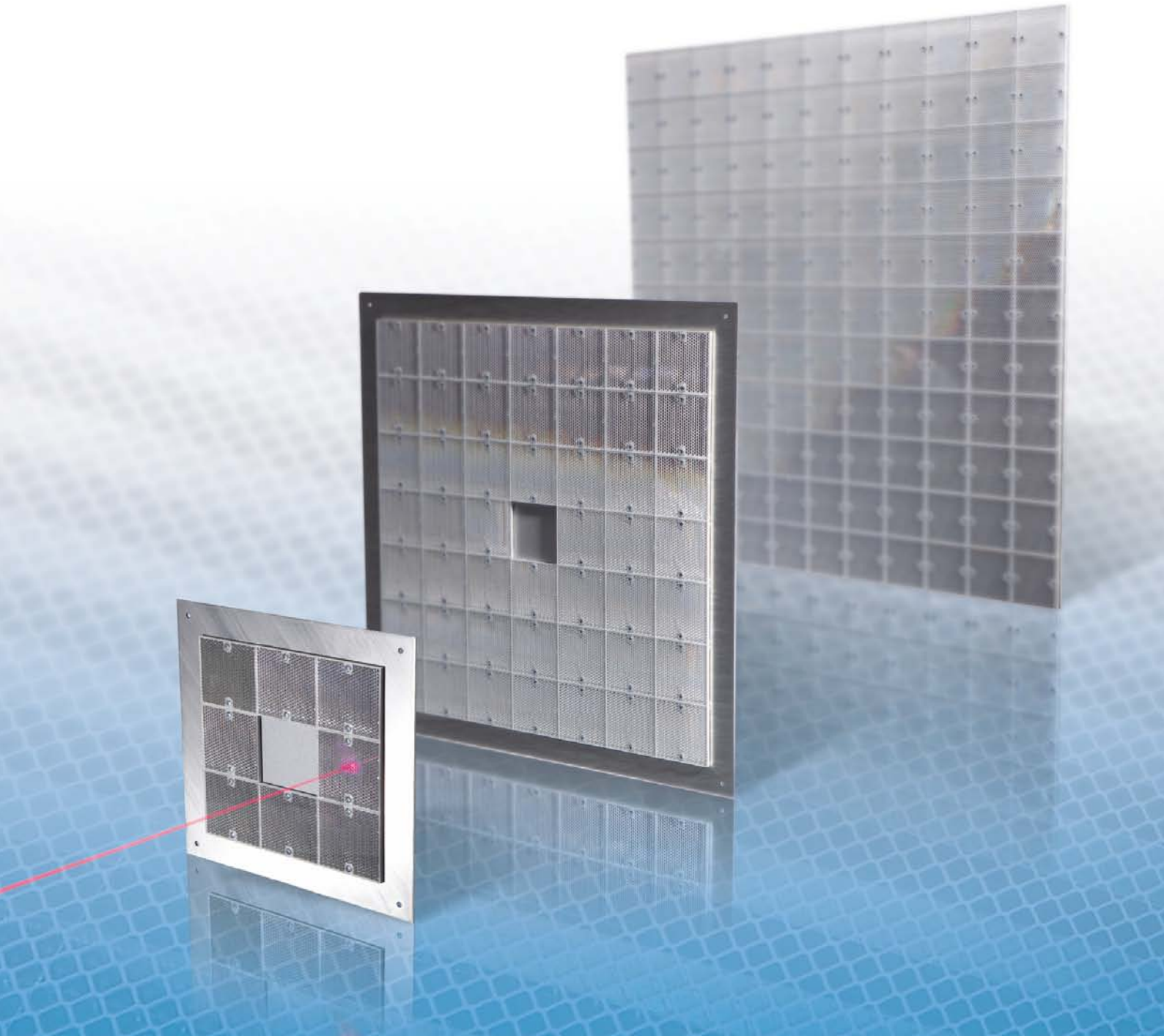

Reflector-based distance sensors place special requirements on return beam elements used. In case of sensing ranges of up to 1200 meters or in outdoor use, the large reflector plates from SICK guarantee maximum possible operation reliability and measuring precision.

# REFLECTORS FOR DISTANCE SENSORS

Standard reflectors

Fine triple reflectors

Special reflectors

Reflectors for distance sensors

Reflective tapes

Mounting systems for reflectors



**PL240F**  
Reflector plate,  
8 x PL80A, screw connection

Dimensional drawing

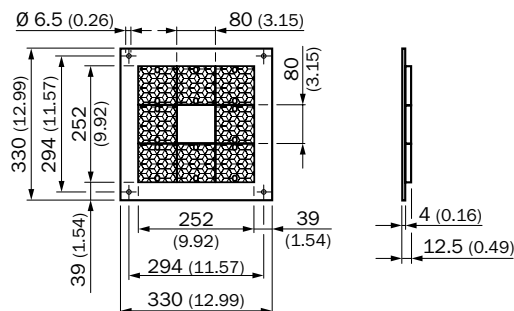

All dimensions in mm (inch)

**Technical data**

Reflection area	252 mm x 252 mm
Material	Base plate: Aluminium
Temperature	-20 °C ... +65 °C

**Ordering information**

Model name	Part no.
PL240F	1013784



**PL240 DG**  
Reflector plate,  
DG tape, screw connection

Dimensional drawing

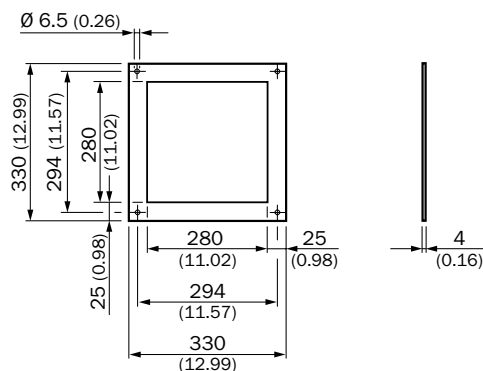

All dimensions in mm (inch)

**Technical data**

Reflection area	280 mm x 280 mm
Material	Base plate: Aluminium
Temperature	-34 °C ... +70 °C

**Ordering information**

Model name	Part no.
PL240 DG	1017910



**PL240 DG-H**  
Reflector plate, DG tape,  
heated, screw connection

Dimensional drawing

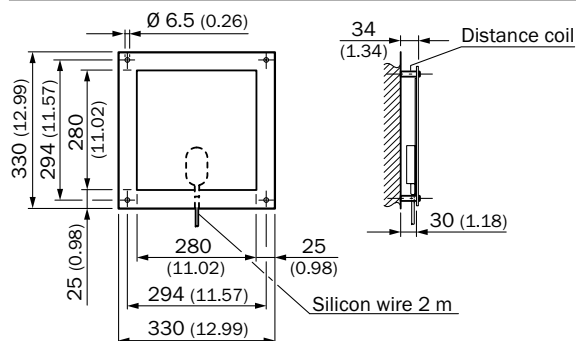

All dimensions in mm (inch)

**Technical data**

Reflection area	280 mm x 280 mm
Material	Base plate: Aluminium
Temperature	-34 °C ... +70 °C

**Ordering information**

Model name	Part no.
PL240 DG-H	1022926



**PL240-7610**  
Reflector plate,  
7610 tape, screw connection

Dimensional drawing

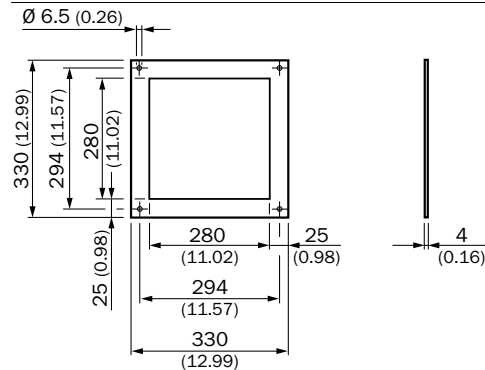

All dimensions in mm (inch)

Technical data

Reflection area	280 mm x 280 mm
Material	Base plate: Aluminium
Temperature	Max. +65 °C

Ordering information

Model name	Part no.
PL240-7610	1019012

Standard reflectors

Fine triple reflectors



**PL560F**  
Reflector plate,  
48 x PL80A, screw connection

Dimensional drawing

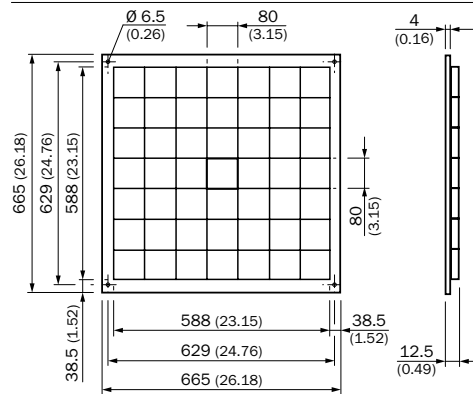

All dimensions in mm (inch)

Technical data

Reflection area	588 mm x 588 mm
Material	Base plate: Aluminium
Temperature	-20 °C ... +65 °C

Ordering information

Model name	Part no.
PL560F	1013785

Special reflectors

Reflectors for distance sensors



**PL560 DG**  
Reflector plate,  
DG tape, screw connection

Dimensional drawing

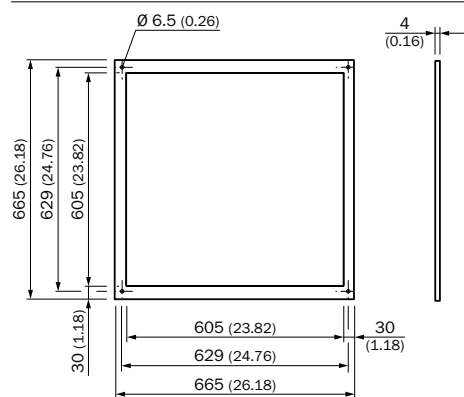

All dimensions in mm (inch)

Technical data

Reflection area	605 mm x 605 mm
Material	Base plate: Aluminium
Temperature	-34 °C ... +70 °C

Ordering information

Model name	Part no.
PL560 DG	1016806

Reflective tapes

Mounting systems for reflectors

Standard reflectors



**PL880F**  
Reflector plate,  
11 x 11 PL80A, screw connection

Dimensional drawing

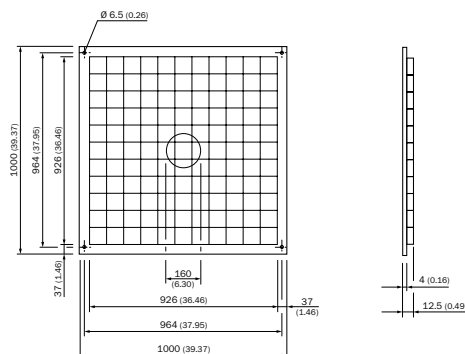

All dimensions in mm (inch)

### Technical data

Reflection area	926 mm x 926 mm
Material	Base plate: Aluminium
Temperature	-20 °C ... +65 °C

### Ordering information

Model name	Part no.
PL880F	1013786

Fine triple reflectors

Special reflectors



**PL880 DG**  
Reflector plate,  
DG tape, screw connection

Dimensional drawing

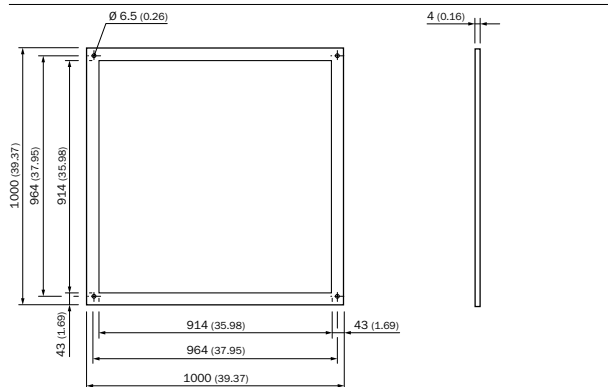

All dimensions in mm (inch)

### Technical data

Reflection area	914 mm x 914 mm
Material	Base plate: Aluminium
Temperature	-34 °C ... +70 °C

### Ordering information

Model name	Part no.
PL880 DG	1018975

Reflectors for distance sensors

Reflective tapes



**PL880 FS01**  
Reflector plate,  
11 x 11 PL80A, screw connection

Dimensional drawing

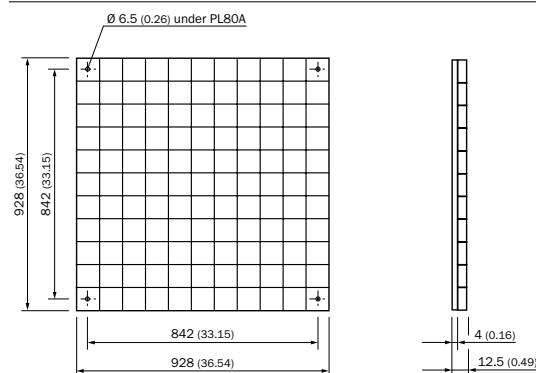

All dimensions in mm (inch)

### Technical data

Reflection area	928 mm x 928 mm
Material	Base plate: Aluminium
Temperature	-20 °C ... +65 °C

### Ordering information

Model name	Part no.
PL880 FS01	1017865

Mounting systems for reflectors



Standard reflectors

Fine triple reflectors

Special reflectors

Reflectors for distance sensors

Reflective tapes

Mounting systems for reflectors

# Reflective tape

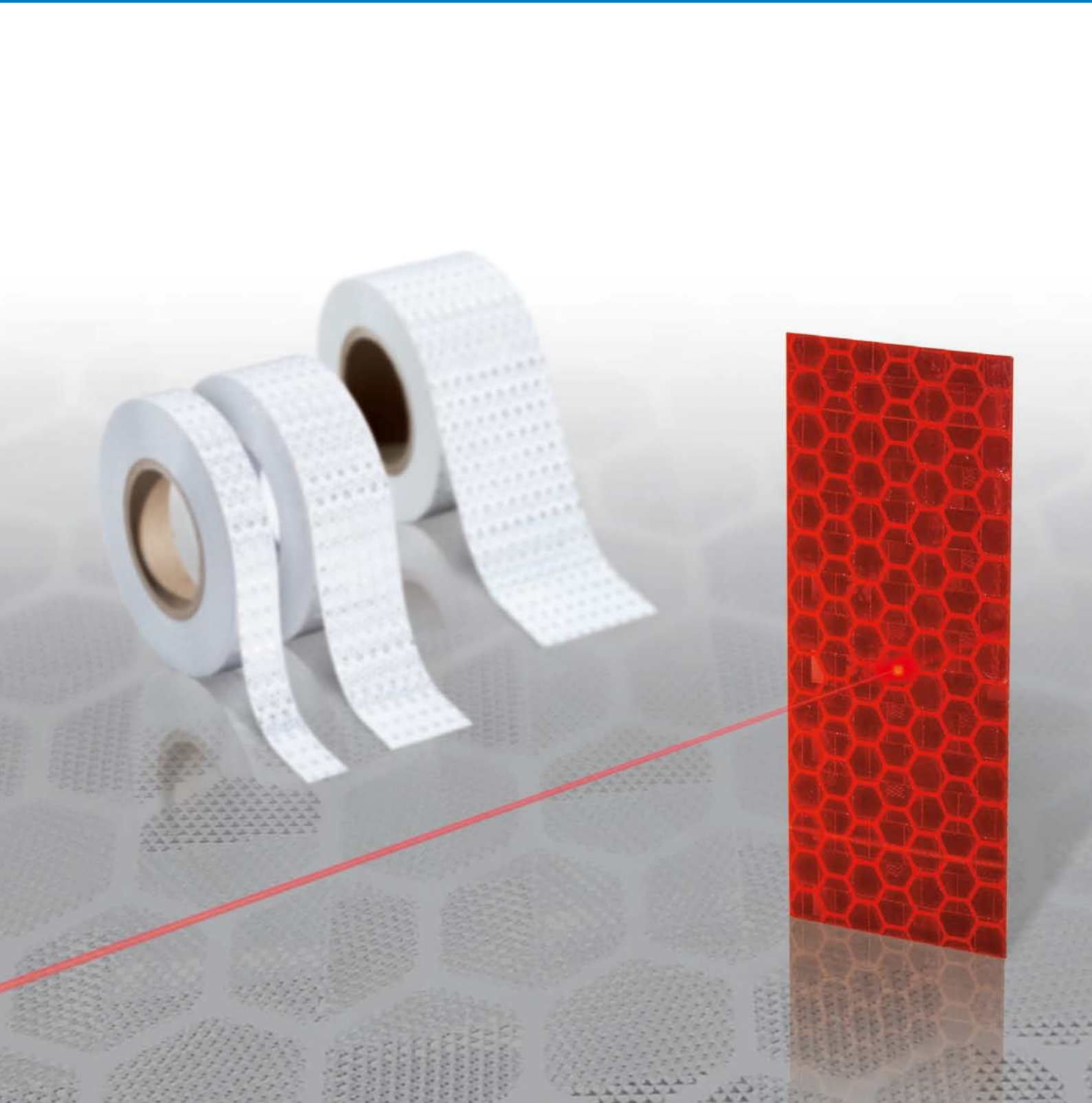

Reflective tapes are always an alternative where the application does not allow the use of a standard reflector. The use of standard reflective tapes from SICK (e.g. REF-Plus, REF-DG) reduces the sensing ranges of the sensor considerably however. REF-AC1000 high-performance reflective tape from SICK on the other hand enables virtually the same sensing ranges as a standard reflector of the same size. The REF-AC1000 is also particularly suited to use with laser photoelectric retro-reflective sensors.

# REFLECTIVE TAPE



## REF-IRF-56

REF-Plus reflective tape, self-adhesive

Dimensional drawing

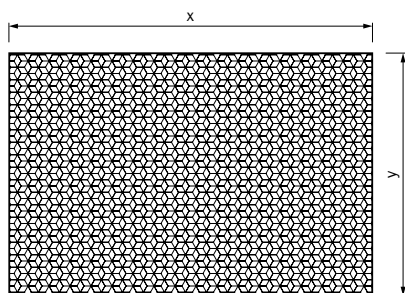

### Technical data

<b>Dimensions</b>	x = 60 mm, y = 50 mm
<b>Temperature</b>	-20 °C ... +60 °C

### Ordering information

Model name	Part no.
REF-IRF-56	5314244



## REF-Plus-R100(-K)

REF-Plus reflective tape, self-adhesive

Dimensional drawing

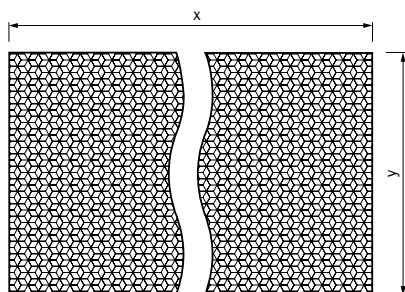

### Technical data

<b>Temperature</b>	-20 °C ... +60 °C
--------------------	-------------------

### Ordering information

Variant	Dimensions	Model name	Part no.
Roll	x = 22,8 m, y = 100 mm	REF-Plus-R100	5319915
Customizable by roll	x max. = 22,8 m, y = 100 mm	REF-Plus-R100-K	4071461



## REF-Plus-R76(-K)

REF-Plus reflective tape, self-adhesive

Dimensional drawing

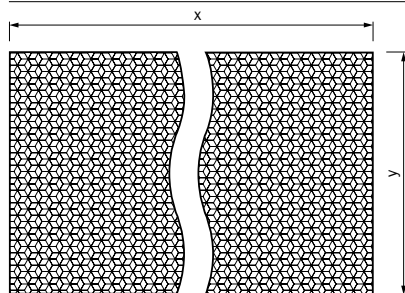

### Technical data

<b>Temperature</b>	-20 °C ... +60 °C
--------------------	-------------------

### Ordering information

Variant	Dimensions	Model name	Part no.
Roll	x = 22,8 m, y = 76 mm	REF-Plus-R76	5322215
Customizable by roll	x max. = 22,8 m, y = 76 mm	REF-Plus-R76-K	4071462



## REF-Plus-R50(-K)

REF-Plus reflective tape, self-adhesive  
Dimensional drawing

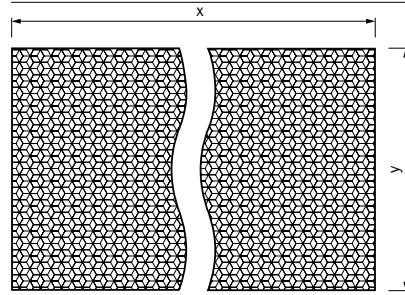

### Ordering information

Variant	Dimensions	Model name	Part no.
Roll	x = 22,8 m, y = 50 mm	REF-Plus-R50	5319981
Customizable by roll	x max. = 22,8 m, y = 50 mm	REF-Plus-R50-K	4051185

### Technical data

Temperature	-20 °C ... +60 °C
-------------	-------------------



## REF-Plus-R25(-K)

REF-Plus reflective tape, self-adhesive  
Dimensional drawing

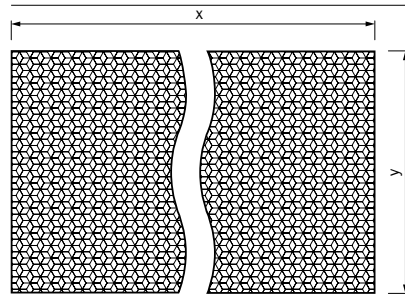

### Ordering information

Variant	Dimensions	Model name	Part no.
Roll	x = 22,8 m, y = 25 mm	REF-Plus-R25	5319929
Customizable by roll	x max. = 22,8 m, y = 25 mm	REF-Plus-R25-K	4051184

### Technical data

Temperature	-20 °C ... +60 °C
-------------	-------------------



## REF-PLUS-3436

REF-Plus reflective tape,  
100 pieces per pack, self-adhesive

Dimensional drawing

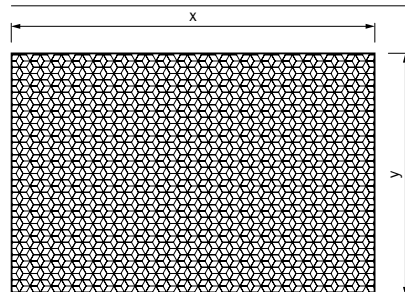

### Technical data

Reflection area	x = 36 mm, y = 34 mm
Temperature	-20 °C ... +60 °C

### Ordering information

Model name	Part no.
REF-Plus-3436	5321337

Standard reflectors

Fine triple reflectors

Special reflectors

Reflectors for distance sensors

Reflective tapes

Mounting systems for reflectors

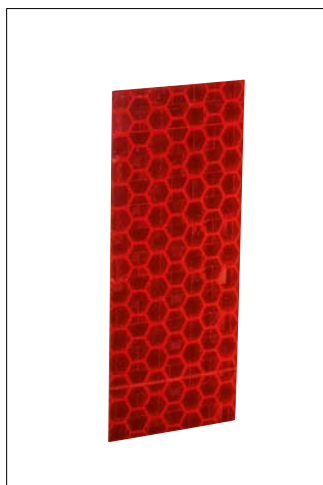

## REF-Plus-RED-2550

REF-Plus reflective tape,  
100 pieces per pack, red, self-adhesive

Dimensional drawing

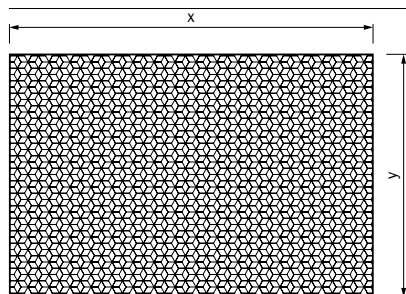

### Technical data

Reflection area	x = 50 mm, y = 25 mm
Temperature	-20 °C ... +60 °C

### Ordering information

Model name	Part no.
REF-Plus-RED-2550	5320285

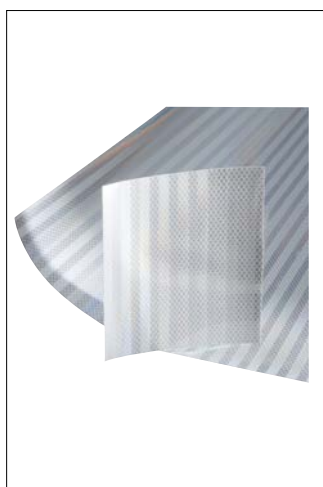

## REF-DG(-K)

Diamond Grade reflective tape, self-adhesive

Dimensional drawing

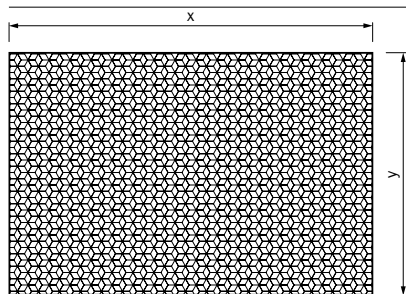

### Technical data

Temperature	-34 °C ... +70 °C
-------------	-------------------

### Ordering information

Variant	Dimensions	Model name	Part no.
Sheet	x = 914 mm, y = 749 mm	REF-DG	5320565
Customizable by sheet	x max. = 914 mm, y max. = 749 mm	REF-DG-K	4019634

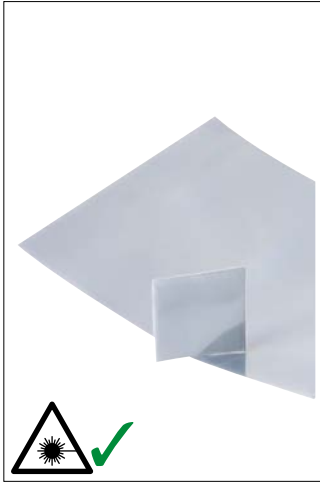

## REF-AC1000(-XX)

AC1000 reflective tape, suitable for laser sensors, self-adhesive, alignment note: see below

Dimensional drawing

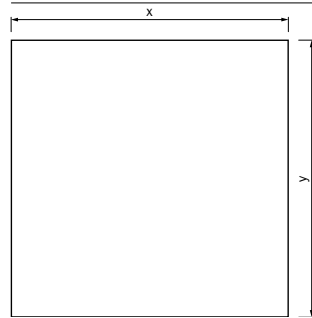

### Ordering information

Variant	Dimensions	Model name	Packaging unit	Part no.
Sheet	x = 225 mm, y = 225 mm	REF-AC1000	1	5319429
Cut	x = 56,3 mm, y = 56,3 mm	REF-AC1000-56	1	4063030
Cut	x = 28,0 mm, y = 28,0 mm	REF-AC1000-28	1	4067881
Cut	x = 73,0 mm, y = 73,0 mm	REF-AC1000-73P01	20	2061557
Cut	x = 20,0 mm, y = 30,0 mm	REF-AC1000-2030P01	25	2061920

### Technical data

Temperature	-20 °C ... +60 °C
-------------	-------------------

## Operating range of REF-AC1000(-XX) reflective tape and P41F reflector.

When using the REF-AC1000 or REF-AC1000-XX reflective tape and the P41F reflector, attention must be paid to the operating range with respect to the angle of rotation. To guarantee reliable operation, the sensor and the reflector must only be used in the following angle of rotation ranges (rotation about the light beam axis), assuming the orientation between sensor and reflector shown in the diagram.

- 340° – 20°
- 70° – 110°
- 160° – 200°
- 250° – 290°

If the sensor is operated in another angle of rotation range when compared to the reflective tape, the reflection performance will be reduced to virtually zero.

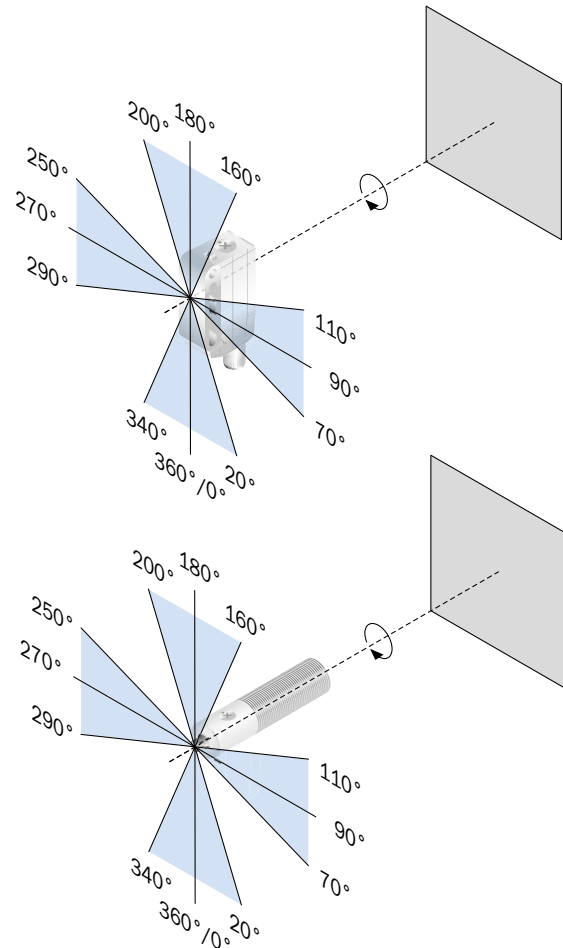



## REF-APM

APM reflective tape, self-adhesive, not suitable for photoelectric retro-reflective sensors with polarizing filter

Dimensional drawing

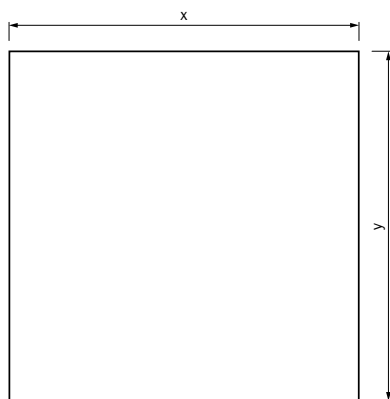

### Technical data

<b>Dimensions</b>	x = 225 mm, y = 225 mm
<b>Temperature</b>	-20 °C ... +60 °C

### Ordering information

Model name	Part no.
REF-APM	4025097



## REF-3290(-K)

reflective tape 3290, self-adhesive, not suitable for photoelectric retro-reflective sensors with polarizing filter

Dimensional drawing

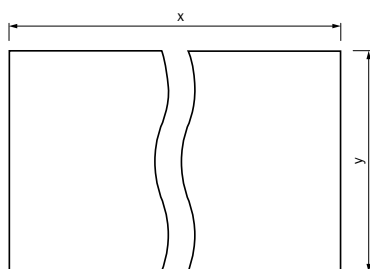

### Technical data

<b>Temperature</b>	-20 °C ... +65 °C
--------------------	-------------------

### Ordering information

Variant	Dimensions	Model name	Part no.
Length customizable by roll	x max. = 4,57 m, y = 914 mm	REF-3290	5301885
Dimensions customizable by roll	x max. = 4,57 m, y max. = 914 mm	REF-3290-K	4018696



## REF-3930-K2

reflective tape 3930, self-adhesive, not suitable for photoelectric retro-reflective sensors with polarizing filter

Dimensional drawing

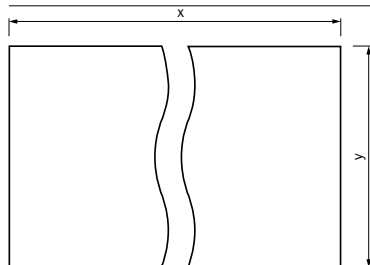

### Technical data

<b>Temperature</b>	-20 °C ... +65 °C
--------------------	-------------------

### Ordering information

Variant	Dimensions	Model name	Part no.
Dimensions customizable by roll	x max. = 4,57 m, y max. = 914 mm	REF-3930-K2	2057035





## REF-7610

Reflective tape 7610, self-adhesive, not suitable for photoelectric retro-reflective sensors with polarizing filter

### Technical data

Temperature	Max. +65 °C
-------------	-------------

### Dimensional drawing

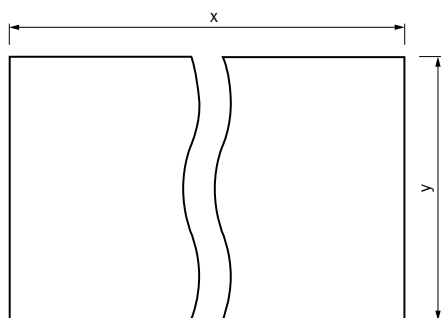

### Ordering information

Variant	Dimensions	Model name	Part no.
Length customizable by roll	x max. = 4,57 m, y = 610 mm	REF-7610-OK4	5600079
Dimensions customizable by roll	x max. = 4,57 m, y max. = 610 mm	REF-7610-K	4018617

Standard reflectors

Fine triple reflectors

Special reflectors

Reflectors for distance sensors

Reflective tapes

Mounting systems for reflectors

# Mounting systems for reflectors

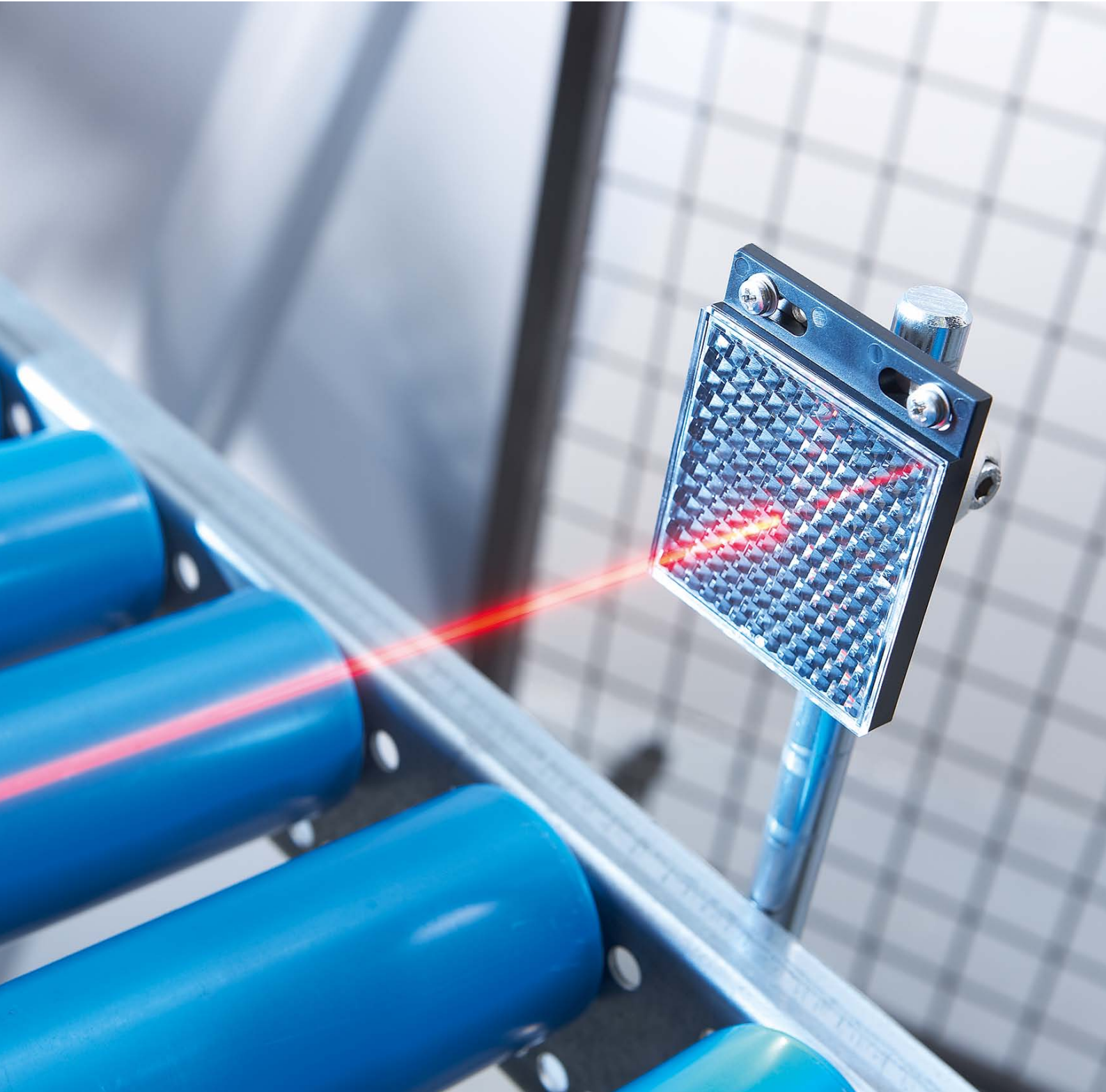

**SICK reflectors and mounting systems are perfectly suited to each other. This offers maximum operational safety as well as saving the user additional costs for development, manufacture and procurement. The majority of our mounting components are permanently available at short-notice – convenient single-source availability in combination with sensors.**

# MOUNTING SYSTEMS FOR REFLECTORS

Standard reflectors

Fine triple reflectors

Special reflectors

Reflectors for distance sensors

Reflective tapes

Mounting systems for reflectors



## BEF-WN-REFX

Universal mounting bracket for reflectors

Dimensional drawing

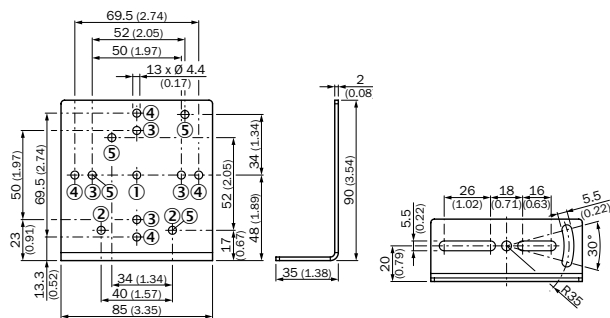

All dimensions in mm (inch)

### Technical data

<b>Material</b>	Steel, galvanised
<b>Dimensions (W x H x L)</b>	85 mm x 90 mm x 35 mm
<b>Delivery</b>	incl. mounting material

### Ordering information

<b>Model name</b>	<b>Part no.</b>
BEF-WN-REFX	2064574



## BEF-KHS-N07(N)

Plate N07(N)  
for universal bar clamp

Dimensional drawing

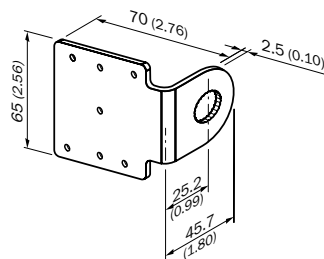

All dimensions in mm (inch)

### Technical data

<b>Material</b>	see ordering information
<b>Delivery</b>	incl. universal bar clamp and mounting material

### Ordering information

<b>Model name</b>	<b>Part no.</b>
BEF-KHS-N07 <sup>1)</sup>	2051613
BEF-KHS-N07N <sup>2)</sup>	2051623

<sup>1)</sup> Plate: Steel, galvanised; clamp: zinc, die-cast.

<sup>2)</sup> Plate: stainless steel (1.4571); clamp: stainless steel (1.4408).





## BEF-KHS-KH3(N)

Universal bar clamp

Dimensional drawing

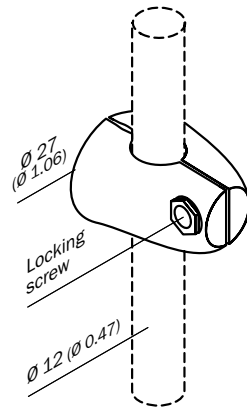

All dimensions in mm (inch)

### Technical data

<b>Material</b>	see ordering information
<b>Delivery</b>	incl. clamp screw

### Ordering information

Model name	Part no.
BEF-KHS-KH3 <sup>1)</sup>	5322626
BEF-KHS-KH3N <sup>2)</sup>	5322627

<sup>1)</sup> Zinc, die-cast.

<sup>2)</sup> Stainless steel (1.4408).

Standard reflectors

Fine triple reflectors

Special reflectors

Reflectors for distance sensors

Reflective tapes

Mounting systems for reflectors

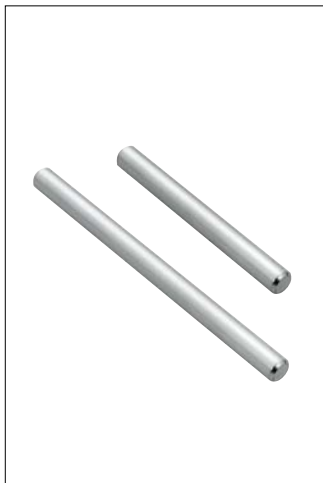

## BEF-MS12G-(N)x

Mounting rod, straight

Dimensional drawing

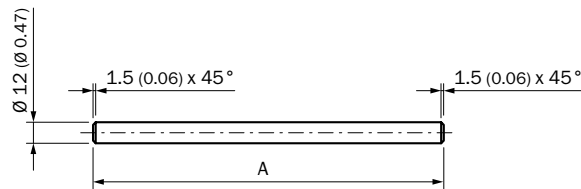

All dimensions in mm (inch)

### Ordering information

Model name	Part no.	Dimension A
BEF-MS12G-A <sup>1)</sup>	4056054	200 mm
BEF-MS12G-NA <sup>2)</sup>	4058914	200 mm
BEF-MS12G-B <sup>1)</sup>	4056055	300 mm
BEF-MS12G-NB <sup>2)</sup>	4058915	300 mm

<sup>1)</sup> Steel, galvanised.

<sup>2)</sup> Stainless steel (1.4571).

### Technical data

<b>Material</b>	see ordering information
-----------------	--------------------------

Standard reflectors

Fine triple reflectors

Special reflectors

Reflectors for distance sensors

Reflective tapes

Mounting systems for reflectors



## BEF-MS12L-(N)x

Mounting rod, L-shaped

Dimensional drawing

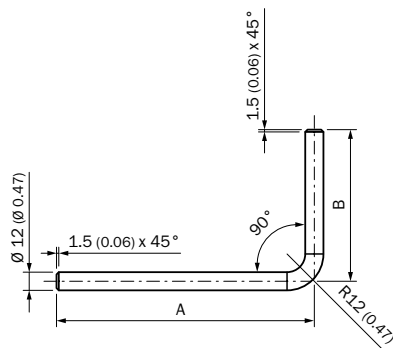

All dimensions in mm (inch)

### Ordering information

Model name	Part no.	Dimension A	Dimension B
BEF-MS12L-A <sup>1)</sup>	4056052	150 mm	150 mm
BEF-MS12L-NA <sup>2)</sup>	4058912	150 mm	150 mm
BEF-MS12L-B <sup>1)</sup>	4056053	250 mm	250 mm
BEF-MS12L-NB <sup>2)</sup>	4058913	250 mm	250 mm

<sup>1)</sup> Steel, galvanised.

<sup>2)</sup> Stainless steel (1.4571).

### Technical data

Material	see ordering information
----------	--------------------------

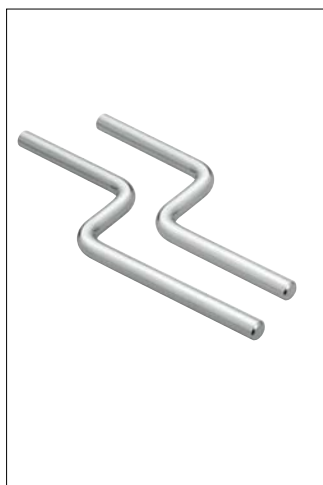

## BEF-MS12Z-(N)x

Mounting rod, Z-shaped

Dimensional drawing

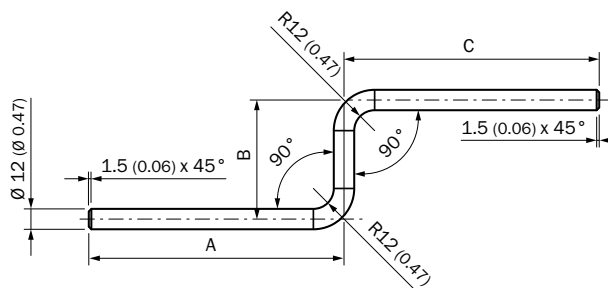

All dimensions in mm (inch)

### Ordering information

Model name	Part no.	Dimension A	Dimension B	Dimension C
BEF-MS12Z-A <sup>1)</sup>	4056056	150 mm	70 mm	150 mm
BEF-MS12Z-NA <sup>2)</sup>	4058916	150 mm	70 mm	150 mm
BEF-MS12Z-B <sup>1)</sup>	4056057	150 mm	70 mm	250 mm
BEF-MS12Z-NB <sup>2)</sup>	4058917	150 mm	70 mm	250 mm

<sup>1)</sup> Steel, galvanised.

<sup>2)</sup> Stainless steel (1.4571).

### Technical data

Material	see ordering information
----------	--------------------------



**BEF-RMC-D12**  
Rod mounting clamp

Dimensional drawing

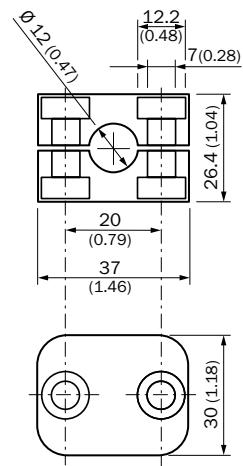

All dimensions in mm (inch)

Technical data

<b>Material</b>	
Mounting clamp	Aluminium
Screws, spring disks	Steel, zinc/nickel plated
<b>Delivery</b>	2 x Screws M6 x 30, 2 x spring disks

Ordering information

Model name	Part no.
BEF-RMC-D12	5321878

Standard reflectors

Fine triple reflectors

Special reflectors

Reflectors for distance sensors

Reflective tapes

Mounting systems for reflectors

Part no.	Model name	Page
1000130	FLV-PL50	34
1000131	SW50	33
1000132	PL50A	11
1000134	SST DO 80-184	34
1000136	OP60-20	33
1000141	OP60-00	33
1000252	SST DO 80-090	34
1000309	SLV-PL50	35
1000382	PL53A	34
1001628	PL51A	11
1002314	PL30A	10
1002315	PL31A	10
1002627	OP61-00	33
1003546	PL22-1	15
1003621	PL22-2	15
1003865	PL80A	12
1004488	PL22-3	15
1009871	PL50HS	32
1011545	PL50HK	32
1012719	PL20A	9
1012720	PL40A	10
1013289	PL180E01	13
1013784	PL240F	38
1013785	PL560F	39
1013786	PL880F	40
1015172	PL21A	9
1016806	PL560 DG	39
1017865	PL880 FS01	40
1017910	PL240 DG	38
1018975	PL880 DG	40
1019012	PL240-7610	39
1022926	PL240 DG-H	38
2051613	BEF-KHS-N07	52
2051623	BEF-KHS-N07N	52
2057035	REF-3930-K2	48
2061557	REF-AC1000-73P01	47
2061920	REF-AC1000-2030P01	47
2063403	PLH25-M12	28
2063404	PLH25-D12	28
2063405	PLV14-A	28
2064574	BEF-WN-REFX	52
4018617	REF-7610-K	49
4018696	REF-3290-K	48
4019634	REF-DG-K	46
4025097	REF-APM	48
4051184	REF-Plus-R25-K	45
4051185	REF-Plus-R50-K	45

Part no.	Model name	Page
4056052	BEF-MS12L-A	54
4056053	BEF-MS12L-B	54
4056054	BEF-MS12G-A	53
4056055	BEF-MS12G-B	53
4056056	BEF-MS12Z-A	54
4056057	BEF-MS12Z-B	54
4058912	BEF-MS12L-NA	54
4058913	BEF-MS12L-NB	54
4058914	BEF-MS12G-NA	53
4058915	BEF-MS12G-NB	53
4058916	BEF-MS12Z-NA	54
4058917	BEF-MS12Z-NB	54
4063030	REF-AC1000-56	47
4067881	REF-AC1000-28	47
4071461	REF-Plus-R100-K	44
4071462	REF-Plus-R76-K	44
5301885	REF-3290	48
5304549	C110A	19
5304812	P250	12
5308843	P250F	24
5308844	PL20F	23
5311210	PL10F	22
5313506	C42-1	18
5313849	PL15F	22
5313922	P34	16
5313923	P40	8
5313924	P55F	24
5314001	P32	8
5314244	REF-IRF-56	44
5314825	P42	8
5315124	P250H	32
5315128	P41F	24
5315172	P25	16
5315548	PL150	14
5318680	P55	17
5318969	P25-2	16
5319385	P25F-1	23
5319429	REF-AC1000	47
5319915	REF-Plus-R100	44
5319929	REF-Plus-R25	45
5319981	REF-Plus-R50	45
5319994	PL18F	22
5320027	P45A	9
5320134	PL40B	11
5320285	REF-Plus-RED-2550	46
5320565	REF-DG	46
5321089	PL20CHEM	29



Part no.	Model name	Page
5321097	P250CHEM	30
5321337	REF-Plus-3436	45
5321625	PL100	13
5321636	PL10F-CHEM	29
5321878	BEF-RMC-D12	55
5322011	PL40A Antifog	32
5322215	REF-Plus-R76	44
5322257	PL34-1	17
5322626	BEF-KHS-KH3	53
5322627	BEF-KHS-KH3N	53
5322673	P50-1	17
5322723	PL72-2	12
5322795	PL81	13
5324281	C42-2	18
5325060	PL81-1F	25
5325185	C64-A	18
5326088	PL40B-CHEM	30
5326089	PL20F-CHEM	29
5326523	PL30F	23
5600079	REF-7610-OK4	49

Model name	Part no.	Page
<b>B</b>		
BEF-KHS-KH3	5322626	53
BEF-KHS-KH3N	5322627	53
BEF-KHS-N07	2051613	52
BEF-KHS-N07N	2051623	52
BEF-MS12G-A	4056054	53
BEF-MS12G-B	4056055	53
BEF-MS12G-NA	4058914	53
BEF-MS12G-NB	4058915	53
BEF-MS12L-A	4056052	54
BEF-MS12L-B	4056053	54
BEF-MS12L-NA	4058912	54
BEF-MS12L-NB	4058913	54
BEF-MS12Z-A	4056056	54
BEF-MS12Z-B	4056057	54
BEF-MS12Z-NA	4058916	54
BEF-MS12Z-NB	4058917	54
BEF-RMC-D12	5321878	55
BEF-WN-REFX	2064574	52
<b>C</b>		
C110A	5304549	19
C42-1	5313506	18
C42-2	5324281	18
C64-A	5325185	18
<b>F</b>		
FLV-PL50	1000130	34
<b>O</b>		
OP60-00	1000141	33
OP60-20	1000136	33
OP61-00	1002627	33
<b>P</b>		
P25	5315172	16
P25-2	5318969	16
P25F-1	5319385	23
P250	5304812	12
P250CHEM	5321097	30
P250F	5308843	24
P250H	5315124	32
P32	5314001	8
P34	5313922	16
P40	5313923	8
P41F	5315128	24
P42	5314825	8
P45A	5320027	9
P50-1	5322673	17
P55	5318680	17
P55F	5313924	24
PL100	5321625	13
PL10F	5311210	22
PL10F-CHEM	5321636	29

Model name	Part no.	Page
PL150	5315548	14
PL15F	5313849	22
PL180E01	1013289	13
PL18F	5319994	22
PL20A	1012719	9
PL20CHEM	5321089	29
PL20F	5308844	23
PL20F-CHEM	5326089	29
PL21A	1015172	9
PL22-1	1003546	15
PL22-2	1003621	15
PL22-3	1004488	15
PL240F	1013784	38
PL240 DG	1017910	38
PL240 DG-H	1022926	38
PL240-7610	1019012	39
PL30A	1002314	10
PL30F	5326523	23
PL31A	1002315	10
PL34-1	5322257	17
PL40A	1012720	10
PL40A Antifog	5322011	32
PL40B	5320134	11
PL40B-CHEM	5326088	30
PL50A	1000132	11
PL50HK	1011545	32
PL50HS	1009871	32
PL51A	1001628	11
PL53A	1000382	34
PL560 DG	1016806	39
PL560F	1013785	39
PL72-2	5322723	12
PL80A	1003865	12
PL81	5322795	13
PL81-1F	5325060	25
PL880 DG	1018975	40
PL880 FS01	1017865	40
PL880F	1013786	40
PLH25-D12	2063404	28
PLH25-M12	2063403	28
PLV14-A	2063405	28
<b>R</b>		
REF-3290	5301885	48
REF-3290-K	4018696	48
REF-3930-K2	2057035	48
REF-7610-0K4	5600079	49
REF-7610-K	4018617	49
REF-AC1000	5319429	47
REF-AC1000-28	4067881	47
REF-AC1000-56	4063030	47

Model name	Part no.	Page
REF-AC1000-73P01	2061557	47
REF-AC1000-2030P01	2061920	47
REF-APM	4025097	48
REF-DG	5320565	46
REF-DG-K	4019634	46
REF-IRF-56	5314244	44
REF-Plus-3436	5321337	45
REF-Plus-R100	5319915	44
REF-Plus-R100-K	4071461	44
REF-Plus-R25	5319929	45
REF-Plus-R25-K	4051184	45
REF-Plus-R50	5319981	45
REF-Plus-R50-K	4051185	45
REF-Plus-R76	5322215	44
REF-Plus-R76-K	4071462	44
REF-Plus-RED-2550	5320285	46
<b>S</b>		
SLV-PL50	1000309	35
SST DO 80-090	1000252	34
SST DO 80-184	1000134	34
SW50	1000131	33

## SICK at a glance

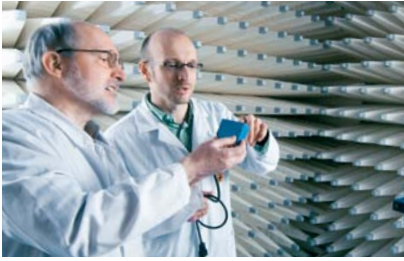

### Leading technologies

With a staff of more than 5,000 and over 50 subsidiaries and representations worldwide, SICK is one of the leading and most successful manufacturers of sensor technology. The power of innovation and solution competency have made SICK the global market leader. No matter what the project and industry may be, talking with an expert from SICK will provide you with an ideal basis for your plans – there is no need to settle for anything less than the best.



### Unique product range

- Non-contact detecting, counting, classifying, positioning and measuring of any type of object or media
- Accident and operator protection with sensors, safety software and services
- Automatic identification with bar code and RFID readers
- Laser measurement technology for detecting the volume, position and contour of people and objects
- Complete system solutions for analysis and flow measurement of gases and liquids



### Comprehensive services

- SICK LifeTime Services – for safety and productivity
- Application centers in Europe, Asia and North America for the development of system solutions under real-world conditions
- E-Business Partner Portal [www.mysick.com](http://www.mysick.com) – price and availability of products, requests for quotation and online orders

Worldwide presence with subsidiaries in the following countries:

Australia  
Belgium/Luxembourg  
Brasil  
Česká Republika  
Canada  
China  
Danmark  
Deutschland  
España  
France  
Great Britain  
India  
Israel  
Italia  
Japan

México  
Nederland  
Norge  
Österreich  
Polska  
România  
Russia  
Schweiz  
Singapore  
Slowenija  
South Africa  
South Korea  
Suomi  
Sverige  
Taiwan  
Türkiye  
United Arab Emirates  
USA

Please find detailed addresses and additional representatives and agencies in all major industrial nations at [www.sick.com](http://www.sick.com)

## X-ON Electronics

Largest Supplier of Electrical and Electronic Components

*Click to view similar products for [Photoelectric Sensors](#) category:*

*Click to view products by [Sick](#) manufacturer:*

Other Similar products are found below :

[E3JM-DS70R4T-US](#) [E3L2DC4](#) [E3RA-DN12 2M](#) [E3RA-DP12 2M](#) [E3S5LE4S](#) [E3S-AD38](#) [E3S-CR11 5M](#) [E3SCT11D5M](#) [E3SCT11M1J03M](#)  
[E3T-SL14R](#) [E3T-SL24 5M](#) [E3T-ST12R](#) [E3X-CN02](#) [E3X-CN11 5M](#) [E3X-CN21 10M](#) [E3ZM-B66](#) [E3ZM-CL81H 2M](#) [E3Z-T62 2M](#)  
[NJL5303R-TE1](#) [PB10CNT15PO](#) [PD60CNX20BP](#) [CX-491-P-J](#) [CX-491-Z](#) [XUM2BKCNL2T](#) [XUM2BKCNL2T](#) [XUM2BNANL2R](#) [Y92E-](#)  
[ES30M](#) [Y92E-GS08SS](#) [ZXTDS04T](#) [ZX-XC4A 4M](#) [E3E23Y2US](#) [E3JM-DS70S4-US](#) [E3RA-RN11 2M](#) [E3S5LE42M](#) [E3S-LS20XB4 5M](#)  
[E3TFD14N](#) [E3T-FD14R](#) [E3T-SL21 5M](#) [E3T-SL21M](#) [E3T-ST11R](#) [E3T-ST12 5M](#) [E3X-DA41-S-M1J 0.3M](#) [E3X-DAB6](#) [E3X-DAG8](#) [E3ZM-](#)  
[B86](#) [E3ZM-CR81 2M](#) [E3ZM-CR86](#) [E3Z-T61A-L 2M](#) [ZX-XGC2R](#) [ZX-XB1A](#)