

2A, 4MHz High Efficiency Synchronous Buck Converter**AP3408**

General Description

The AP3408 is a current mode, PWM synchronous buck DC/DC converter, capable of driving a 2A load with high efficiency, excellent line and load regulation. It operates in continuous PWM mode.

The AP3408 integrates synchronous P-channel and N-channel power MOSFET switches with low on-resistance. It is ideal for portable applications powered from a single Li-ion battery. 100% duty cycle and low on-resistance P-channel internal power MOSFET can maximize the battery life.

The switching frequency of AP3408 can be programmable from 300kHz to 4MHz, which allows small-sized components, such as capacitors and inductors. A standard series of inductors from several different manufacturers are available. This feature greatly simplifies the design of switch-mode power supplies.

The AP3408 is available in DFN-3×3-10 and PSOP-8 packages.

Features

- Input Voltage Range: 2.6 to 5.5V
- Adjustable Output from 0.8 to 5V
- 0.8V Reference Voltage with $\pm 2\%$ Precision
- Output Current: 2A
- High Efficiency up to 95%
- Low $R_{DS(on)}$ Internal Switches
- Programmable Frequency: 300kHz to 4MHz
- Current Mode Control
- Forced Continuous-mode Operation
- 100% Duty Cycle
- Synchronizable Switching Frequency
- Power Good Output Voltage Monitoring
- Built-in Soft-start
- Built-in Short Circuit Protection
- Built-in Thermal Shutdown Protection
- Built-in Current Limit Function

Applications

- Portable Media Player
- Digital Still and Video Cameras
- Notebook

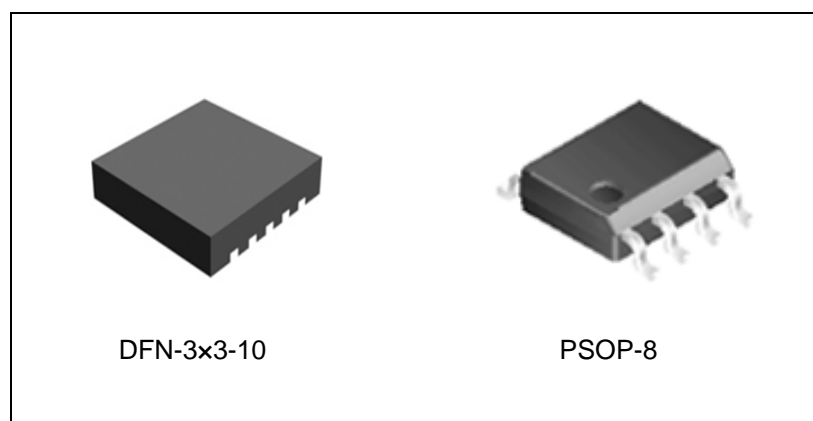

Figure 1. Package Types of AP3408

2A, 4MHz High Efficiency Synchronous Buck Converter
AP3408
Pin Configuration

Figure 2. Pin Configuration of AP3408 (Top View)

Pin Description

Pin Number		Pin Name	Description
DFN-3x3-10	PSOP-8		
1	1	SHDN/RT	Oscillator resistor input. Connect a resistor to GND from this pin to set the switching frequency. Forcing this pin to V_{DD} to shutdown the device
2		SYNC	External clock synchronization input. The oscillation frequency can be synchronized to an external oscillation applied to this pin. When tied to V_{DD} , the internal oscillator is selected
3	2	GND	Signal ground. All small-signal ground, such as the compensation components and the exposed pad should be connected to this pin, which in turn connects to PGND at one point
4	3	SW	Internal power switch output. Connect this pin with one terminal of the inductor
5	4	PGND	Power ground. Connect this pin as close as possible to CIN and COUT
6	5	PVDD	Power input supply. Decouple this pin to PGND with a capacitor
7	6	VDD	Signal input supply. Decouple this pin to GND with a capacitor. Normally V_{DD} is equal to V_{PVDD}
8		PGOOD	Power Good Indicator. Open-drain logic output that is pulled to ground when the output voltage is not within $\pm 12.5\%$ of regulation point
9	7	FB	Feedback voltage. This pin is the inverting input of internal error amplifier. It senses the converter output voltage through an external resistor divider. The internal reference voltage is 0.8V, which determines the output voltage through the resistor divider
10	8	COMP	Compensation input. This pin is the output of internal error amplifier. Connect external compensation elements to this pin to stabilize the control loop

2A, 4MHz High Efficiency Synchronous Buck Converter
AP3408
Functional Block Diagram

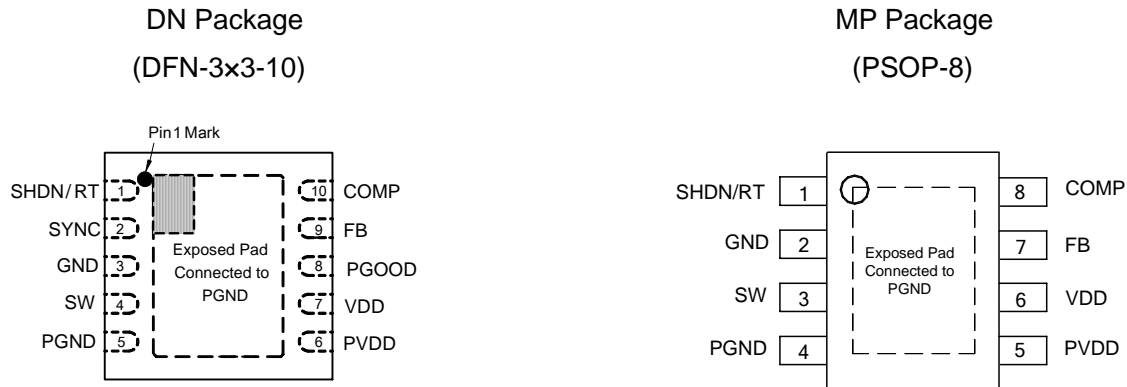
Figure 3. Functional Block Diagram of AP3408



2A, 4MHz High Efficiency Synchronous Buck Converter

AP3408

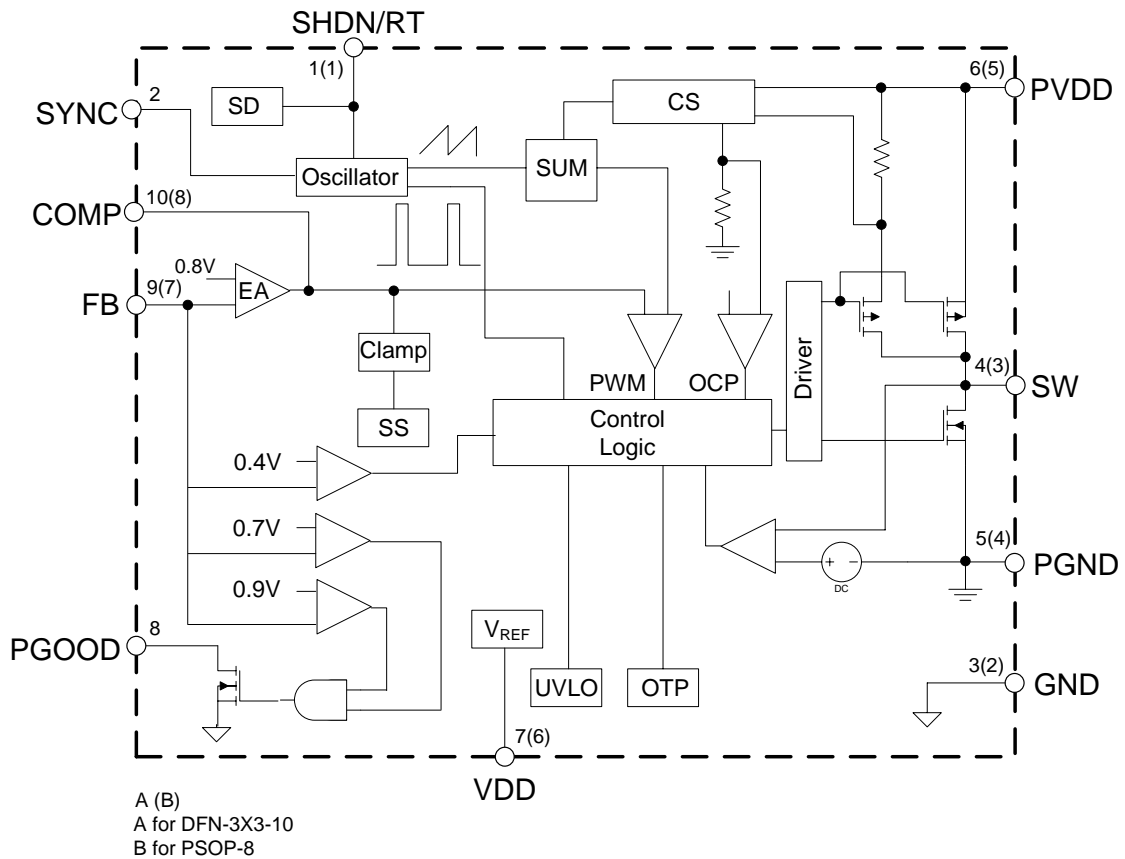
Ordering Information

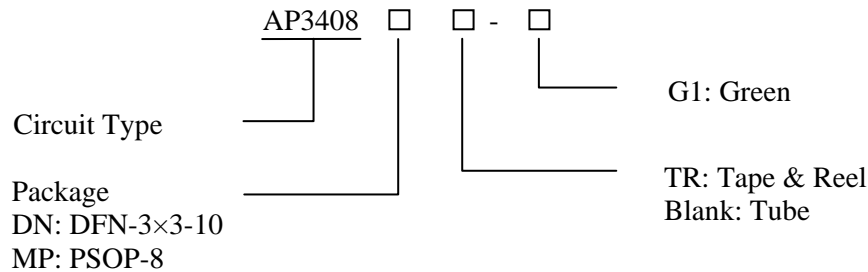

Package	Temperature Range	Part Number	Marking ID	Packing Type
		Green	Green	
DFN-3×3-10	-40 to 125°C	AP3408DNTR-G1	BFA	Tape & Reel
PSOP-8		AP3408MP-G1	3408MP-G1	Tube
		AP3408MPTR-G1	3408MP-G1	Tape & Reel

BCD Semiconductor's Pb-free products, as designated with "G1" suffix in the part number, are RoHS compliant and green.

Absolute Maximum Ratings (Note 1)

Parameter	Symbol	Value	Unit
VDD Pin Voltage	V_{DD}	-0.3 to 6	V
PVDD Pin Voltage	V_{PVDD}	-0.3 to 6	V
FB Pin Voltage	V_{FB}	-0.3 to 6	V
COMP Pin Voltage	V_{COMP}	-0.3 to 6	V
SW Pin Voltage	V_{SW}	-0.3 to $V_{IN}+0.3$	V
SHDN/RT Pin Voltage	$V_{SHDN/RT}$	-0.3 to 6	V
Thermal Resistance	θ_{JA}	DFN-3×3-10	110
		PSOP-8	75
Operating Junction Temperature	T_J	150	°C
Storage Temperature	T_{STG}	-65 to 150	°C
Lead Temperature (Soldering, 10 sec)	T_{LEAD}	260	°C
ESD (Machine Model)		200	V
ESD (Human Body Model)		2000	V

Note 1: Stresses greater than those listed under “Absolute Maximum Ratings” may cause permanent damage to the device. These are stress ratings only, and functional operation of the device at these or any other conditions beyond those indicated under “Recommended Operating Conditions” is not implied. Exposure to “Absolute Maximum Ratings” for extended periods may affect device reliability.

**2A, 4MHz High Efficiency Synchronous Buck Converter****AP3408****Recommended Operating Conditions**

Parameter	Symbol	Min	Max	Unit
Input Voltage	V_{IN}	2.6	5.5	V
Maximum Output Current	$I_{OUT(MAX)}$	2		A
Operating Junction Temperature	T_J	-40	125	°C

Electrical Characteristics

$V_{IN}=V_{DD}=V_{PVDD}=3.3V$, $T_A=25^\circ C$, unless otherwise specified.

Parameters	Symbol	Conditions	Min	Typ	Max	Unit
INPUT SECTION						
Input Voltage Range	V_{DD}		2.6		5.5	V
Supply Current	I_Q	$V_{FB}=0.75V$, No Switching		460		μA
Shutdown Supply Current	I_{SHDN}	Shutdown, $V_{IN}=5.5V$			1	μA
Under Voltage Threshold Lockout	V_{UVLO}	V_{DD} Rising		2.2		V
Under Voltage Hysteresis Lockout	V_{HUVLO}			300		mV
FEEDBACK SECTION						
Feedback Voltage	V_{FB}		0.784	0.8	0.816	V
FB Pin Bias Current	I_{FB}			0.1	0.4	μA
Current Sense Transresistance	R_T			0.2		Ω
Switching Leakage Current		$V_{SHDN/RT}=V_{IN}$ $=5.5V$			1	μA
Error Gain Amplifier Voltage	G_V			800		
Error Amplifier Trans-conductance	G_S			800		$\mu A/V$

**2A, 4MHz High Efficiency Synchronous Buck Converter****AP3408****Electrical Characteristics (Continued)** $V_{IN}=V_{DD}=V_{PVDD}=3.3V$, $T_A=25^{\circ}C$, unless otherwise specified.

Parameters	Symbol	Conditions	Min	Typ	Max	Unit
OSCILLATOR SECTION						
RT Pin Voltage	V_{RT}			0.8		V
Switching Frequency	f_{OSC}	$R_{OSC}=330k\Omega$	0.8	1	1.2	MHz
		ADJ Frequency	0.3		4	MHz
Maximum Duty Cycle	D_{MAX}	$V_{FB}=0.75V$	100			%
POWER SWITCH SECTION						
Switch Current Limit	I_{LIMIT}	$V_{FB}=0.75V$	2.2	3.8		A
Internal P-FET On Resistance	R_{PDSON}	$I_{SW}=500mA$		0.11	0.16	Ω
Internal N-FET On Resistance	R_{NDSON}	$I_{SW}=-500mA$		0.11	0.17	Ω
SHDN/RT SECTION						
Shutdown Threshold				$V_{DD}-0.7$	$V_{DD}-0.4$	V
PGOOD SECTION						
PGOOD Voltage Range				± 12.5	± 15	%
PGOOD Pull Down Resistance					120	Ω
TOTAL DEVICE						
Output Current	I_{OUT}	$V_{DD}=2.6$ to $5.5V$ $V_{OUT}=2.5V$	2			A
Output Voltage Line Regulation	LNR	$V_{DD}=2.7$ to $5.5V$ $I_{OUT}=100mA$		0.4		%/V
Output Voltage Load Regulation	LOD	$I_{OUT}=0.01$ to $2A$		± 0.2		%
Soft-start Time	t_{SS}	$I_{OUT}=10mA$		1.5		ms
Thermal Shutdown Temperature	T_{OTSD}			160		$^{\circ}C$
Thermal Shutdown Temperature Hysteresis	T_{HYS}			20		$^{\circ}C$



2A, 4MHz High Efficiency Synchronous Buck Converter

AP3408

Typical Performance Characteristics

$V_{IN}=V_{DD}=V_{PVDD}=3.3V$, $T_A=25^\circ C$, unless otherwise specified.

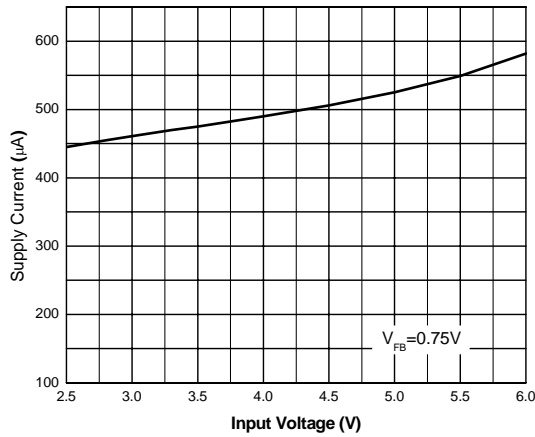

Figure 4. Supply Current vs. Input Voltage

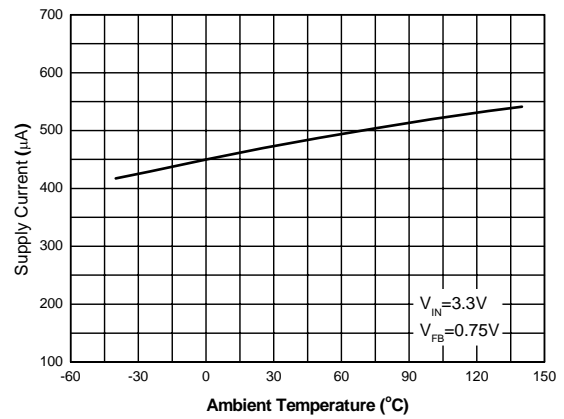

Figure 5. Supply Current vs. Ambient Temperature

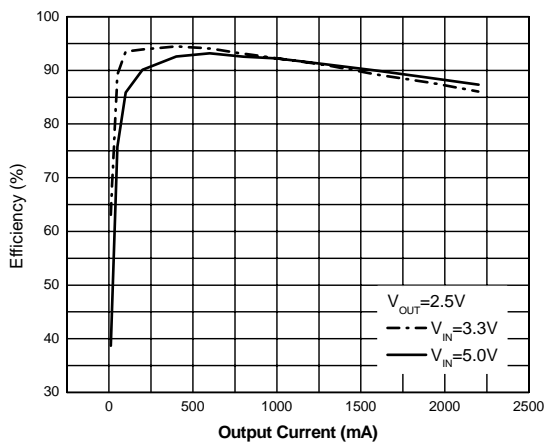

Figure 6. Efficiency vs. Output Current

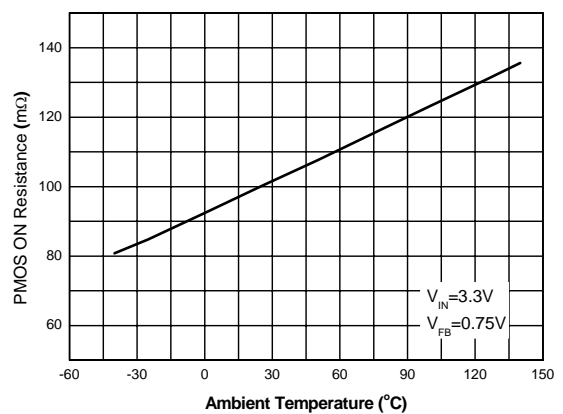

Figure 7. PMOS ON Resistance vs. Ambient Temperature



2A, 4MHz High Efficiency Synchronous Buck Converter

AP3408

Typical Performance Characteristics (Continued)

$V_{IN}=V_{DD}=V_{PVDD}=3.3V$, $T_A=25^\circ C$, unless otherwise specified.

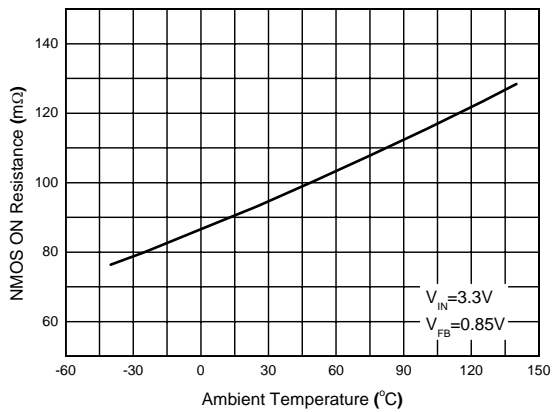

Figure 8. NMOS ON Resistance vs. Ambient Temperature

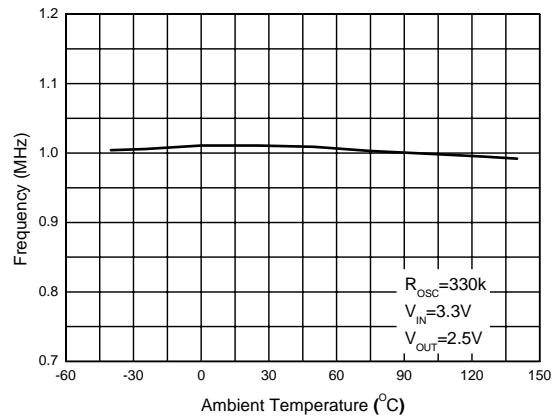

Figure 9. Frequency vs. Ambient Temperature

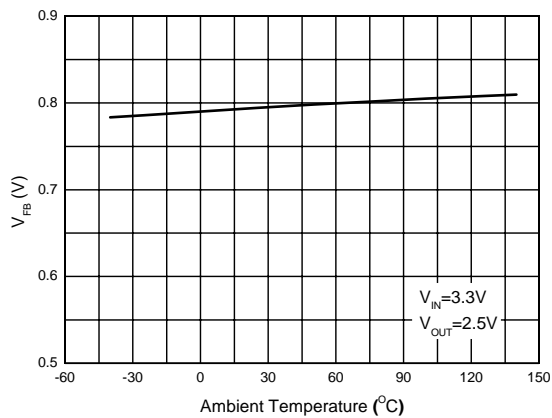

Figure 10. V_{FB} vs. Ambient Temperature

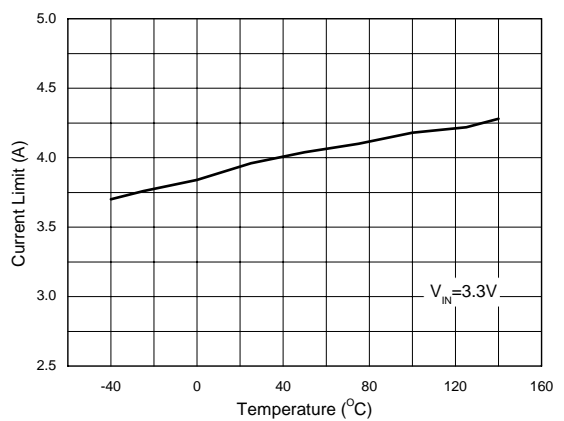

Figure 11. Current Limit vs. Ambient Temperature

Typical Application

Figure 12. Typical Application of AP3408

2A, 4MHz High Efficiency Synchronous Buck Converter

AP3408

Mechanical Dimensions

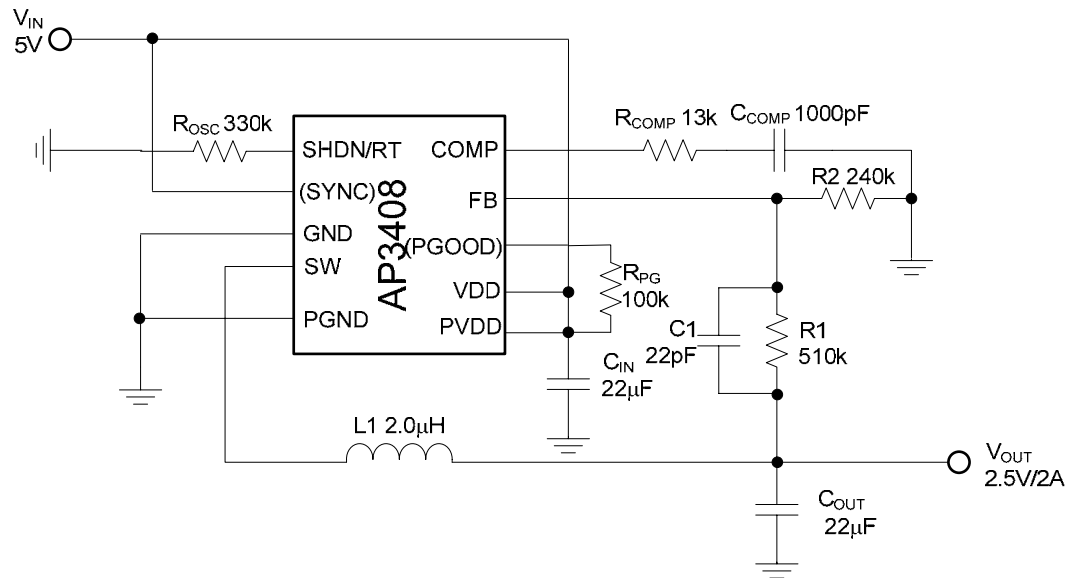
DFN-3x3-10

Unit: mm(inch)

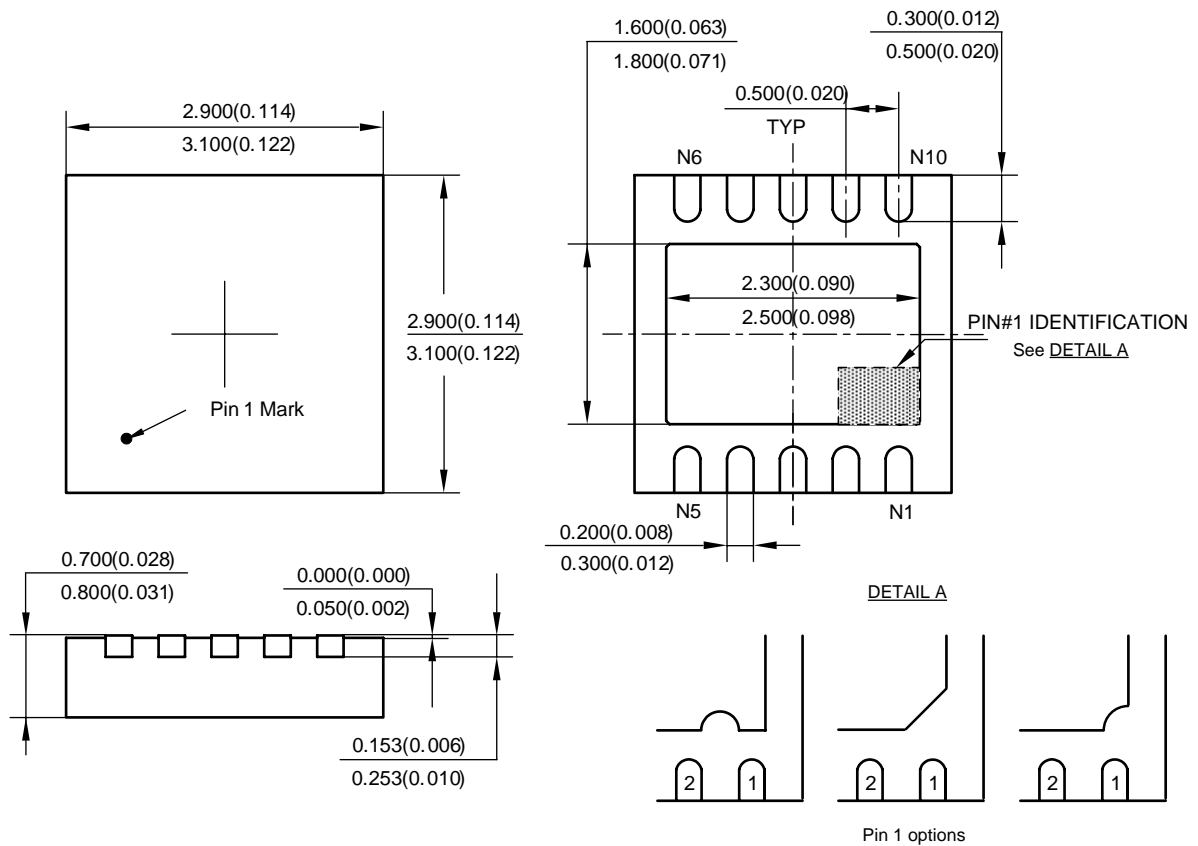

Mechanical Dimensions (Continued)

PSOP-8

Unit: mm(inch)

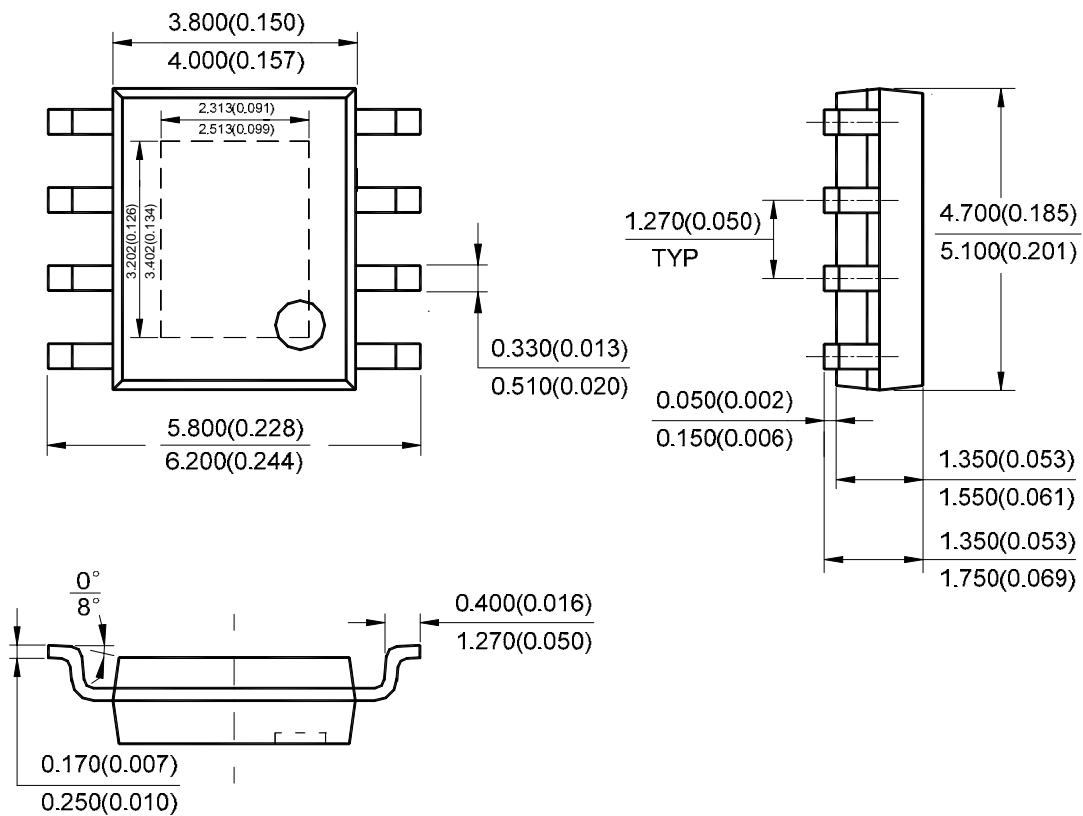

Note: Eject hole, oriented hole and mold mark is optional.



BCD Semiconductor Manufacturing Limited

<http://www.bcdsemi.com>

IMPORTANT NOTICE

BCD Semiconductor Manufacturing Limited reserves the right to make changes without further notice to any products or specifications herein. BCD Semiconductor Manufacturing Limited does not assume any responsibility for use of any its products for any particular purpose, nor does BCD Semiconductor Manufacturing Limited assume any liability arising out of the application or use of any its products or circuits. BCD Semiconductor Manufacturing Limited does not convey any license under its patent rights or other rights nor the rights of others.

MAIN SITE

- Headquarters

BCD Semiconductor Manufacturing Limited

No. 1600, Zi Xing Road, Shanghai ZiZhu Science-based Industrial Park, 200241, China
Tel: +86-21-24162266, Fax: +86-21-24162277

- Wafer Fab

Shanghai SIM-BCD Semiconductor Manufacturing Co., Ltd.

800 Yi Shan Road, Shanghai 200233, China
Tel: +86-21-6485 1491, Fax: +86-21-5450 0008

REGIONAL SALES OFFICE

Shenzhen Office

Shanghai SIM-BCD Semiconductor Manufacturing Co., Ltd., Shenzhen Office

Unit A Room 1203, Skyworth Bldg., Gaoxin Ave. 1.S., Nanshan District, Shenzhen, China
Tel: +86-755-8826 7951
Fax: +86-755-8826 7865

Taiwan Office

BCD Semiconductor (Taiwan) Company Limited

4F, 298-1, Rui Guang Road, Nei-Hu District, Taipei, Taiwan
Tel: +886-2-2656 2808
Fax: +886-2-2656 2806

USA Office

BCD Semiconductor Corp.

30920 Huntwood Ave. Hayward, CA 94544, USA
Tel : +1-510-324-2988
Fax: +1-510-324-2788

X-ON Electronics

Largest Supplier of Electrical and Electronic Components

Click to view similar products for [Voltage Regulators - Switching Regulators](#) category:

Click to view products by [Diodes Incorporated](#) manufacturer:

Other Similar products are found below :

[LX7186A](#) [622616F](#) [632259F](#) [FAN53610AUC33X](#) [MP2148GQD-33-P](#) [MP2374DS-LF-Z](#) [EN6310QA](#) [NCP81108MNTXG](#)
[NCP81109BMNTXG](#) [L79M05TL-E](#) [FAN48610BUC45X](#) [R3](#) [LV5710GP-TE-L-H](#) [430464BB](#) [455605G](#) [AZ7500BMTR-E1](#) [MIC23156-](#)
[0YML-T5](#) [MIC4930YFL-T5](#) [MP8763GLE-P](#) [KE177614](#) [418569H](#) [455596X](#) [511087D](#) [030908C](#) [063375FB](#) [067501FB](#) [099508GB](#)
[EP5358LUA](#) [NCP81102MNTXG](#) [715715H](#) [FAN48611UC53X](#) [FAN53611AUC12X](#) [MAX809TTR](#) [MAX77596ETBC+T](#)
[MAX77596ETBB+T](#) [MAX16905AUE/V+](#) [NCP6332CMTAATBG](#) [NCV890203MWTXG](#) [LX7176A](#) [ISL8018IRAJZ](#) [MP2162AGQH-Z](#)
[MAX17544ATP+T](#) [MCP1623T-IMC](#) [MCP1642B-18IMC](#) [MCP1642BT-30I/MS](#) [MCP1642D-50IMC](#) [MCP1642D-50IMS](#) [MCP1642D-](#)
[ADJIMC](#) [MC34063LBBGEVB](#) [MCP1252T-33X50IMS](#)