

### Long Stroke and Sliding Contact Construction Sealed Switches

### TURQUOISE STROKE SWITCHES

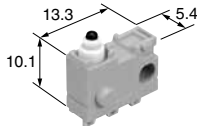

(Unit: mm)

RoHS compliant

### FEATURES

- For pin plunger type, it maintains a long stroke OT (Over Travel) with over 2.2 mm on the NO side and over 2.5 mm on the NC side.
- Since contact force does not depend on the operation stroke, the range of possible use over the entire stroke is greatly increased.
- High contact reliability to support low level switching loads
- Highly effective sealing for resistance against adverse environments
- Silent operation with sliding contact

### TYPICAL APPLICATIONS

- Automobiles (detection of door opening and closing and shift lever position, etc.)
- Household appliances (vacuum cleaners, air conditioners, washing machines, etc.)

### ORDERING INFORMATION

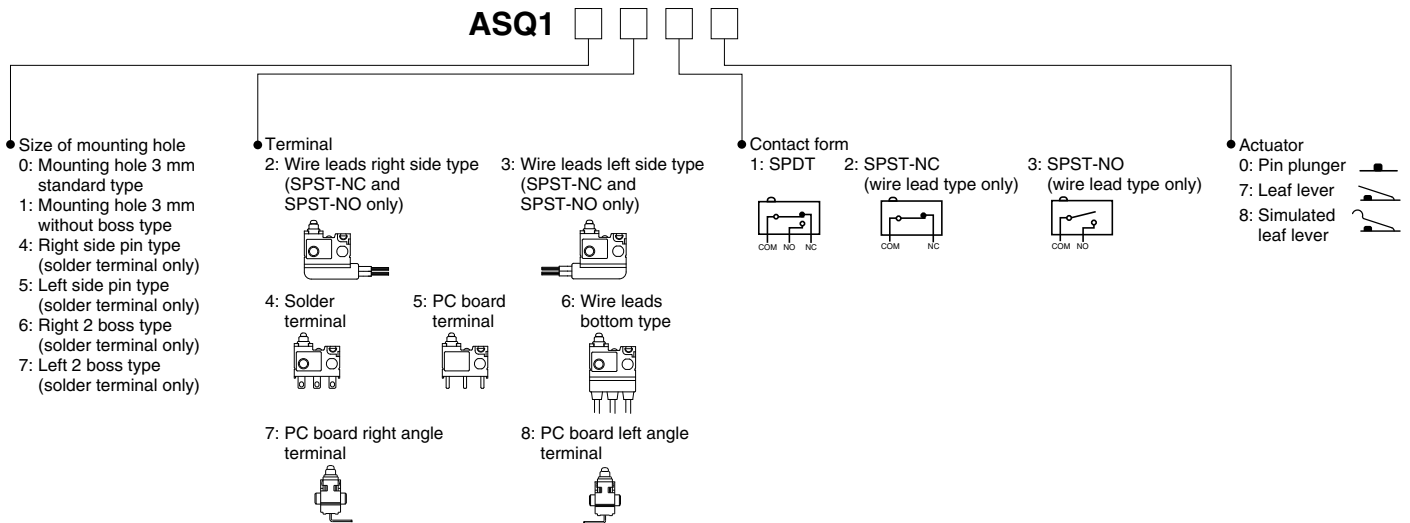

Note: Not every combination is available. Please refer to the following table, "PRODUCT TYPES".

### PRODUCT TYPES

#### Terminal type (Mounting hole 3mm standard type/Mounting hole 3mm without boss type/2 boss type/Side pin type)

Actuator	Operating Force OF (Max.)	Mounting hole 3mm standard type			Mounting hole 3mm without boss type	Right 2 boss type	Left 2 boss type	Right side pin type	Left side pin type
		Solder terminal	PC right angle terminal	PC left angle terminal					
Pin plunger	1.5N	ASQ10410	ASQ10710	ASQ10810	ASQ11510	ASQ16410	ASQ17410	ASQ14410	ASQ15410
Leaf lever	1.7N	ASQ10417	ASQ10717	ASQ10817	ASQ11517	ASQ16417	ASQ17417	ASQ14417	ASQ15417
Simulated leaf lever	1.5N	ASQ10418	ASQ10718	ASQ10818	ASQ11518	ASQ16418	ASQ17418	ASQ14418	ASQ15418

# Turquoise Stroke Switches (ASQ1)

## ■ Wire leads bottom type (Mounting hole 3mm standard type)

Actuator	Operating Force OF (Max.)	Wire leads bottom type (Mounting hole 3mm standard type)		
		SPDT	SPST-NC	SPST-NO
Pin plunger	1.5N	ASQ10610	ASQ10620	ASQ10630
Leaf lever	1.7N	ASQ10617	ASQ10627	ASQ10637
Simulated leaf lever	1.5N	ASQ10618	ASQ10628	ASQ10638

## ■ Wire leads side type (Mounting hole 3mm standard type)

Actuator	Operating Force OF (Max.)	Wire leads right side type (Mounting hole 3mm standard type)		Wire leads left side type (Mounting hole 3mm standard type)	
		SPST-NC	SPST-NO	SPST-NC	SPST-NO
Pin plunger	1.5N	ASQ10220	ASQ10230	ASQ10320	ASQ10330
Leaf lever	1.7N	ASQ10227	ASQ10237	ASQ10327	ASQ10337
Simulated leaf lever	1.5N	ASQ10228	ASQ10238	ASQ10328	ASQ10338

## SPECIFICATIONS

### ■ Contact rating

1 mA 5 V DC to 100 mA 30 V DC

Note: Please consult us regarding 42 V DC rating.

### ■ Operation environment and conditions

Item	Specifications
Ambient and storage temperature	-40°C to +85°C (no freezing and condensing)
Allowable operating speed	30 to 500 mm/sec.
Max. operating cycle rate	120 cpm

Note: When switching at low and high speeds or under vibration, or in high-temperature, high-humidity environments, life and performance may be reduced significantly depending on the load capacity. Please consult us.

### ■ Electrical characteristics

Dielectric strength (Initial)	Between non-continuous terminals: 600 Vrms, Between each terminal and other exposed metal parts: 1,500 Vrms, Between each terminal and ground: 1,500 Vrms (at detection current of 1 mA)
Insulation resistance (Initial)	Min. 100 MΩ (at 500 V DC insulation resistance meter) (Locations measured same as dielectric strength.)
Contact resistance (Initial)	Max. 1 Ω (by voltage drop 0.1 A 6 to 8 V DC)

### ■ Characteristics

Item		Specifications	
Electrical switching life	5 V DC 1 mA (Resistive load)	Min. $5 \times 10^5$	Switching frequency: 20 times/min. Conduction ratio: 1:1 Pushbutton operation speed: 100 mm/s Pushbutton switching position: free position (FP) to operation limit position (TTP)
	16 V DC 50 mA (Resistive load)	Min. $5 \times 10^5$	
	30 V DC 100 mA (Resistive load)	Min. $2 \times 10^5$	
Vibration resistance (malfunction vibration resistance)		Single amplitude: 0.75 mm Amplitude of vibration: 10 to 55 Hz (4 minutes cycle) Direction and time: 30 minutes each in X, Y and Z directions	
Shock resistance (malfunction shock resistance)		Shock value: 980 m/s <sup>2</sup> Direction and time: 5 times each in X, Y and Z directions	
Vibration resistance endurance		Frequency of vibration: 33.3 Hz, Acceleration: 43.1 m/s <sup>2</sup> Direction and time: 8 hours each in X, Y and Z directions	
Terminal strength		6 N min. (each direction) *Terminal deformation possible.	
Heat resistance		85°C 500 hours	
Cold resistance		-40°C 500 hours	
Humidity resistance		40°C 95% RH 500 hours	
Thermal shock resistance		30 min. at 85°C to 30 min at -40°C for 1,000 cycles	
Unit weight		Approx. 0.8 g (terminal type), Approx. 5.4 g (wire leads side type)	
Protection grade		IP67 (except exposed terminal part of terminal type)	

Note: As long as there are no particular designations, the following conditions apply to the test environment.

- Ambient temperature: 5 to 35°C
- Relative humidity: 25 to 85% RH
- Air pressure: 86 to 106 kPa

## ■ Protection gread

### 1) JIS C0920: Waterproof type

A concrete testing method is to check for any adverse effect on the structure after leaving it submerged for 30 minutes under 1 m of water (with temperature difference between water and switch no larger than 5°C).

### 2) IEC 60529: IP67 (waterproof type)

A concrete testing method is to check for any adverse effect on the structure after leaving it submerged for 30 minutes under 1 m of water (with temperature difference between water and switch no larger than 5°C).

### 3) JIS D0203: Equivalent of D2

A concrete testing method is to check for any adverse effect on the structure after leaving it submerged for 30 minutes under 10 cm of water (with temperature difference between water and switch no larger than 30°C).

## ■ Operating characteristics

Characteristics		Unit	Pin plunger	Leaf lever	Simulated leaf lever
Operating Force (max. OF) *Note 2		N	1.5	1.7	1.5
Total travel Force (max. TF) (reference value)		N	(2.0)	(3.1)	(2.8)
Free Position (max. FP)	From mounting boss and hole center line	mm	9.2	11.5	14.4
	From standoff		13.4	15.7	18.6
Operating Position on NC side OP (NC) *Note 3	From mounting boss and hole center line	mm	8.7±0.3	9.8±0.5	12.5±0.5
	From standoff		12.9±0.3	14.0±0.5	16.7±0.5
Operating Position on NO side OP (NO) *Note 4	From mounting boss and hole center line	mm	8.4±0.3	9.3±0.5	12.0±0.5
	From standoff		12.6±0.3	13.5±0.5	16.2±0.5
Release Position on NC side RP (NC) *Note 5	From mounting boss and hole center line	mm	8.8±0.3	10.1±0.5	12.9±0.5
	From standoff		13.0±0.3	14.3±0.5	17.1±0.5
Release Position on NO side RP (NO) *Note 6	From mounting boss and hole center line	mm	8.5±0.3	9.6±0.5	12.4±0.5
	From standoff		12.7±0.3	13.8±0.5	16.6±0.5
Over travel on NC side (min. OT (NC))		mm	2.5	3.1	3.3
Over travel on NO side (min. OT (NO))		mm	2.2	2.6	2.8
Total Travel Position (TTP) (reference value)	From mounting boss and hole center line	mm	(5.9)	(6.2)	(8.7)
	From standoff		(10.1)	(10.4)	(12.9)

Notes: 1. The above indicates the characteristics when operating the pushbutton from the vertical direction.

2. Indicates operation load for NO contact to achieve ON status.

3. Indicates position for NC contact to achieve OFF status.

4. Indicates position for NO contact to achieve ON status.

5. Indicates position for NC contact to achieve ON status.

6. Indicates position for NO contact to achieve OFF status.

## OPERATION CONCEPT DIAGRAM

### Contact form: terminal type

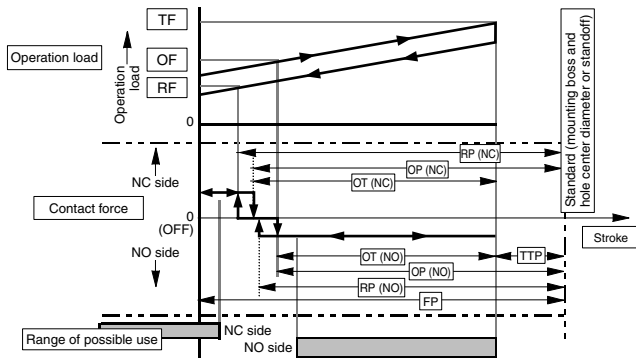

## DATA

### Applicable current range (Reference)

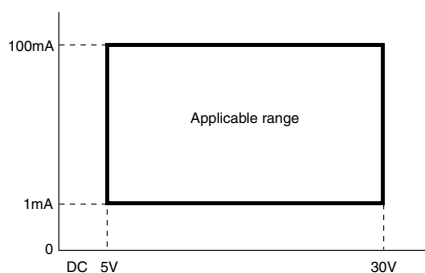

# Turquoise Stroke Switches (ASQ1)

## DIMENSIONS

(Unit: mm) General tolerance:  $\pm 0.25$

The CAD data of the products with a **CAD Data** mark can be downloaded from: <http://industrial.panasonic.com/ac/e/>

### Terminal type: Mounting hole 3 mm, standard type Pin plunger

#### CAD Data

#### External dimensions

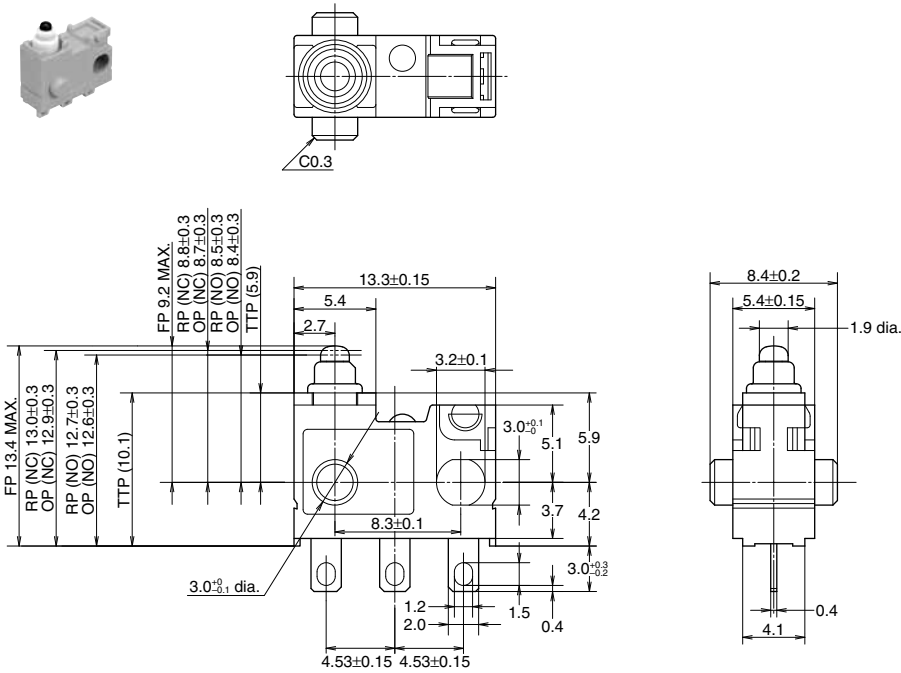

Operating Force (max. OF)		1.5N
Free Position (max. FP)	From mounting boss and hole center line	9.2mm
	From standoff	13.4mm
Operating Position on NC side OP (NC)	From mounting boss and hole center line	8.7±0.3mm
	From standoff	12.9±0.3mm
Operating Position on NO side OP (NO)	From mounting boss and hole center line	8.4±0.3mm
	From standoff	12.6±0.3mm
Release Position on NC side RP (NC)	From mounting boss and hole center line	8.8±0.3mm
	From standoff	13.0±0.3mm
Release Position on NO side RP (NO)	From mounting boss and hole center line	8.5±0.3mm
	From standoff	12.7±0.3mm
Over travel on NC side (min. OT (NC))		2.5mm
Over travel on NO side (min. OT (NO))		2.2mm

### Terminal type: Leaf lever

#### CAD Data

#### External dimensions

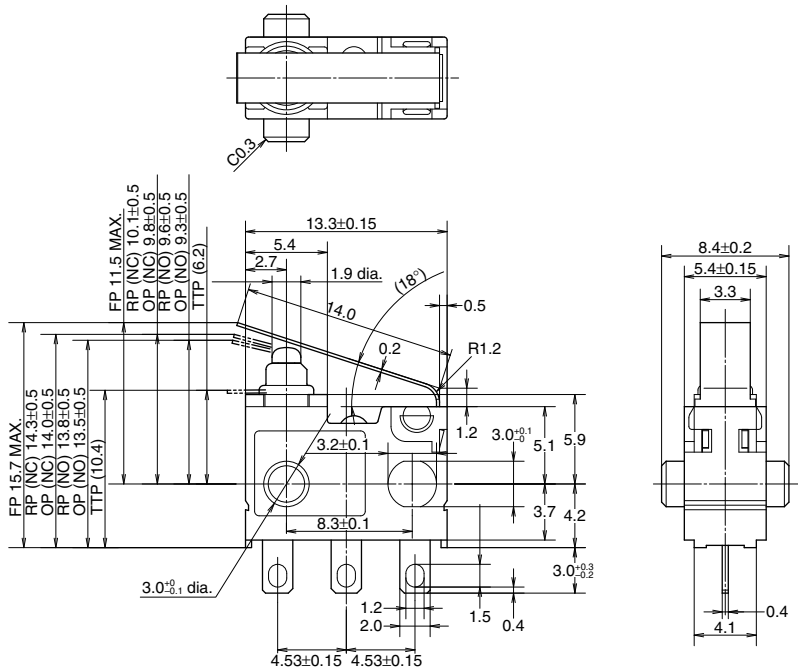

Operating Force (max. OF)		1.7N
Free Position (max. FP)	From mounting boss and hole center line	11.5mm
	From standoff	15.7mm
Operating Position on NC side OP (NC)	From mounting boss and hole center line	9.8±0.5mm
	From standoff	14.0±0.5mm
Operating Position on NO side OP (NO)	From mounting boss and hole center line	9.3±0.5mm
	From standoff	13.5±0.5mm
Release Position on NC side RP (NC)	From mounting boss and hole center line	10.1±0.5mm
	From standoff	14.3±0.5mm
Release Position on NO side RP (NO)	From mounting boss and hole center line	9.6±0.5mm
	From standoff	13.8±0.5mm
Over travel on NC side (min. OT (NC))		3.1mm
Over travel on NO side (min. OT (NO))		2.6mm

Note: When switching at high speed or under shock, lever endurance may drop. Therefore, please be sure to conduct an endurance evaluation under actual switching conditions.

Terminal type: Simulated leaf lever

CAD Data

External dimensions

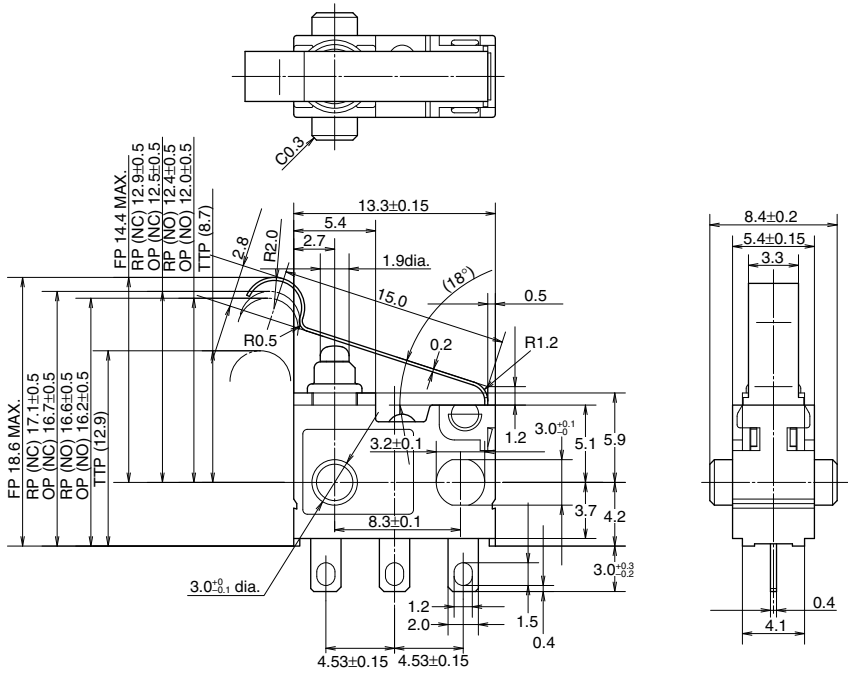

Operating Force (max. OF)		1.5N
Free Position (max. FP)	From mounting boss and hole center line	14.4mm
	From standoff	18.6mm
Operating Position on NC side OP (NC)	From mounting boss and hole center line	12.5±0.5mm
	From standoff	16.7±0.5mm
Operating Position on NO side OP (NO)	From mounting boss and hole center line	12.0±0.5mm
	From standoff	16.2±0.5mm
Release Position on NC side RP (NC)	From mounting boss and hole center line	12.9±0.5mm
	From standoff	17.1±0.5mm
Release Position on NO side RP (NO)	From mounting boss and hole center line	12.4±0.5mm
	From standoff	16.6±0.5mm
Over travel on NC side (min. OT (NC))		3.3mm
Over travel on NO side (min. OT (NO))		2.8mm

Note: When switching at high speed or under shock, lever endurance may drop. Therefore, please be sure to conduct an endurance evaluation under actual switching conditions.

PC board terminal: Mounting hole 3 mm without boss type

CAD Data

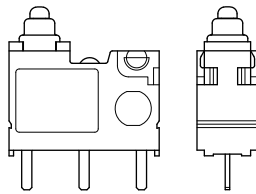

PC board terminal

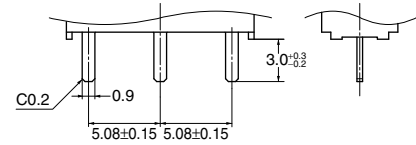

PC board pattern

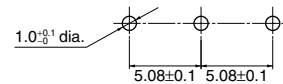

Terminal type: Right side pin type

CAD Data

External dimensions

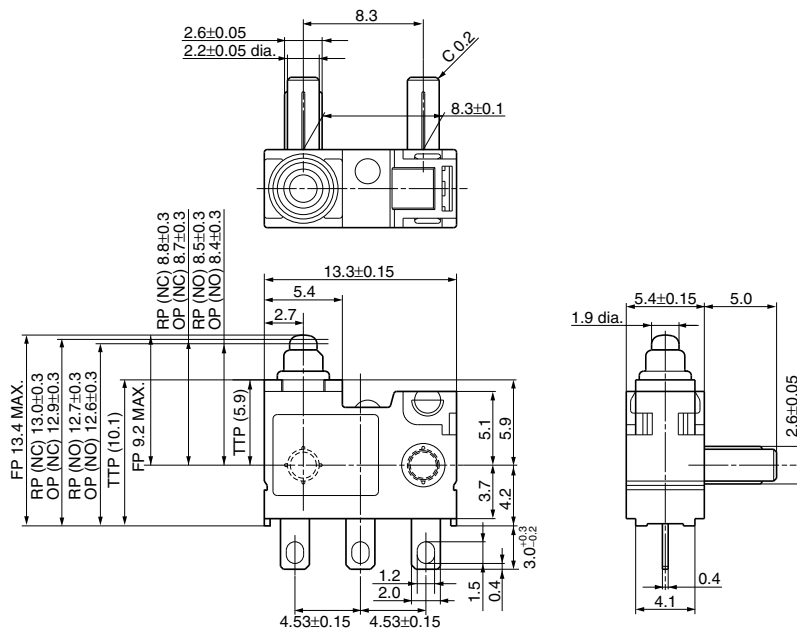

# Turquoise Stroke Switches (ASQ1)

## Terminal type: Left side pin type

### CAD Data

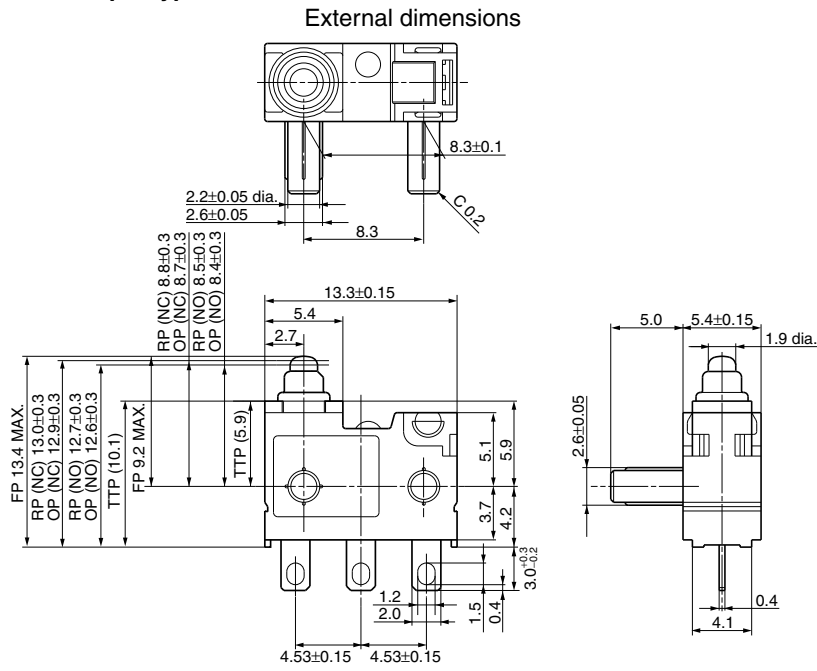

## Terminal type: Right 2 boss type

### CAD Data

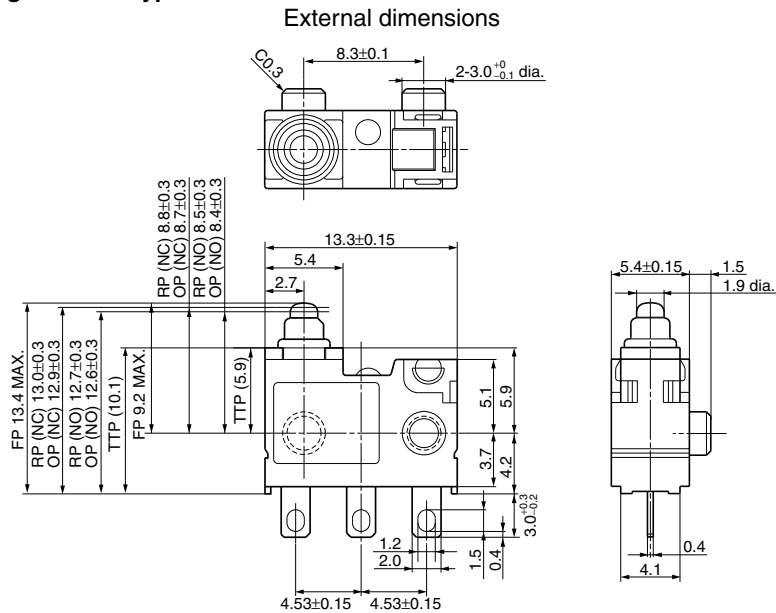

## Terminal type: Left 2 boss type

### CAD Data

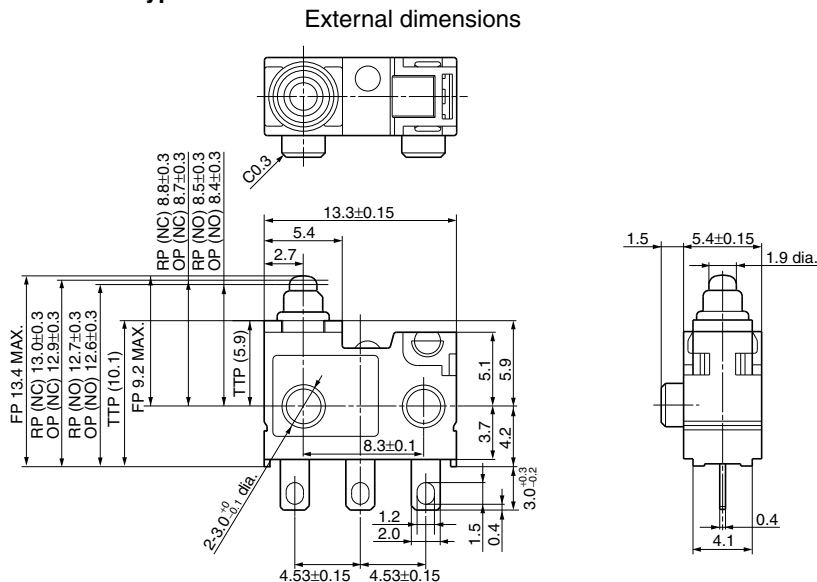

■ Angle terminal type: Mounting hole 3 mm, standard type (Right type)

CAD Data

External dimensions

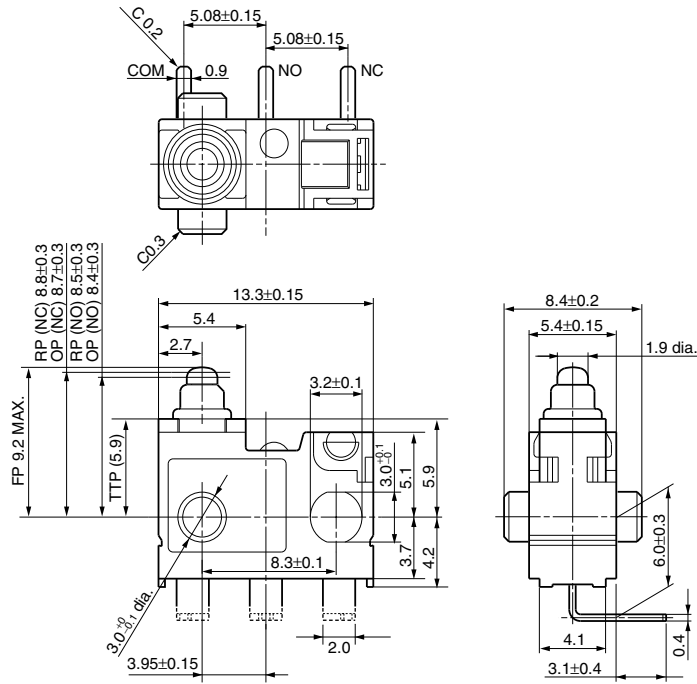

■ Angle terminal type: Mounting hole 3 mm, standard type (Left type)

CAD Data

External dimensions

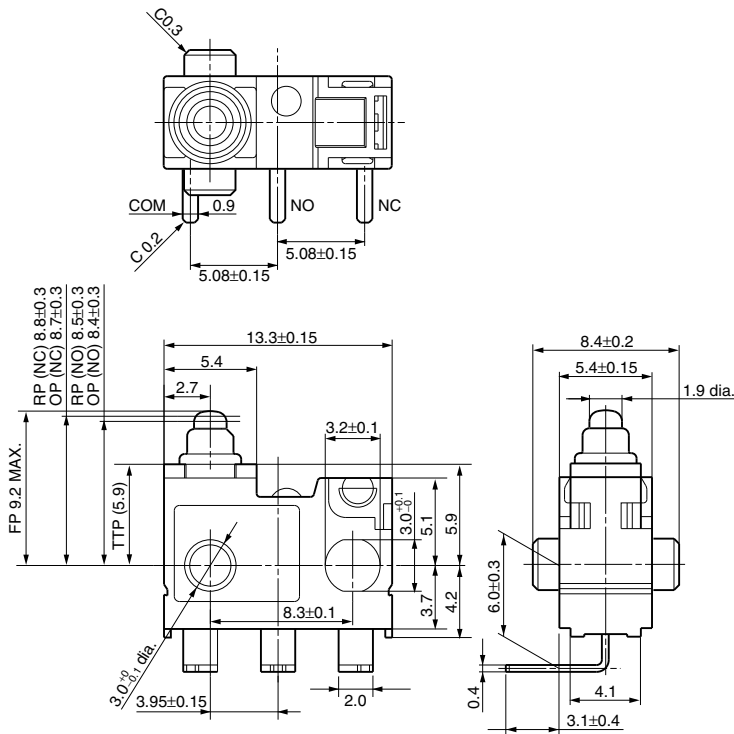

# Turquoise Stroke Switches (ASQ1)

## ■ Wire leads bottom type: Mounting hole 3 mm, standard type

### CAD Data

### External dimensions

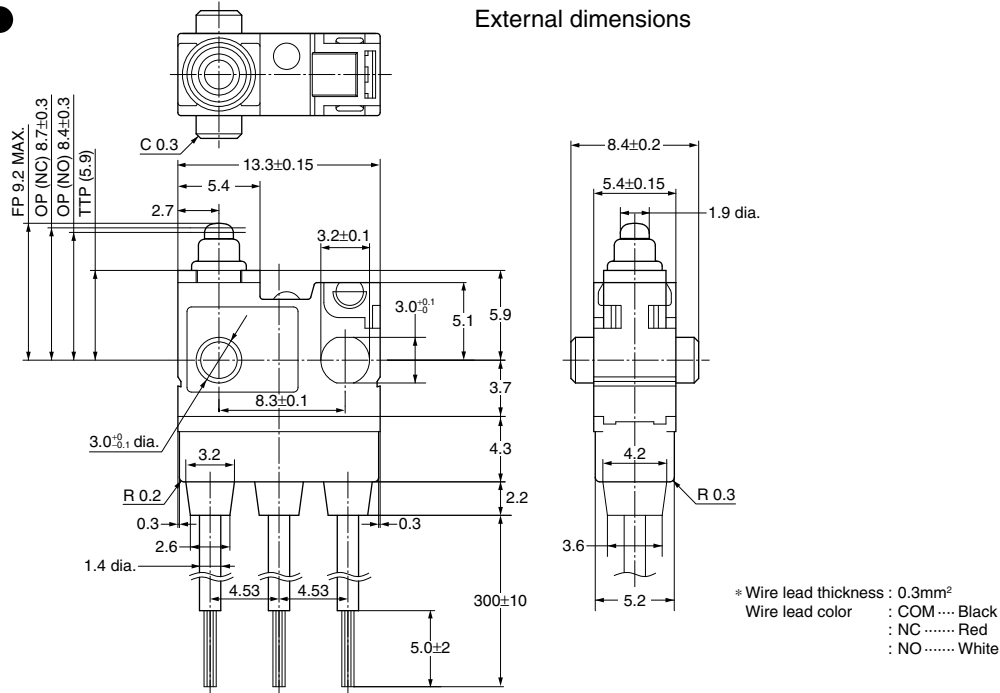

## ■ Wire leads right side type: Mounting hole 3 mm, standard type

### CAD Data

### External dimensions

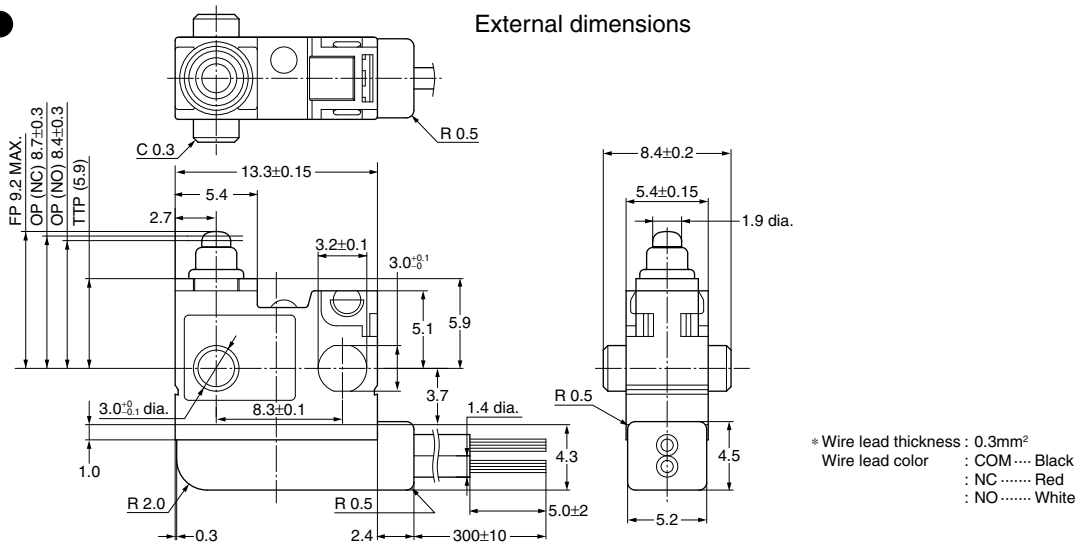

## ■ Wire leads left side type: Mounting hole 3 mm, standard type

### CAD Data

### External dimensions

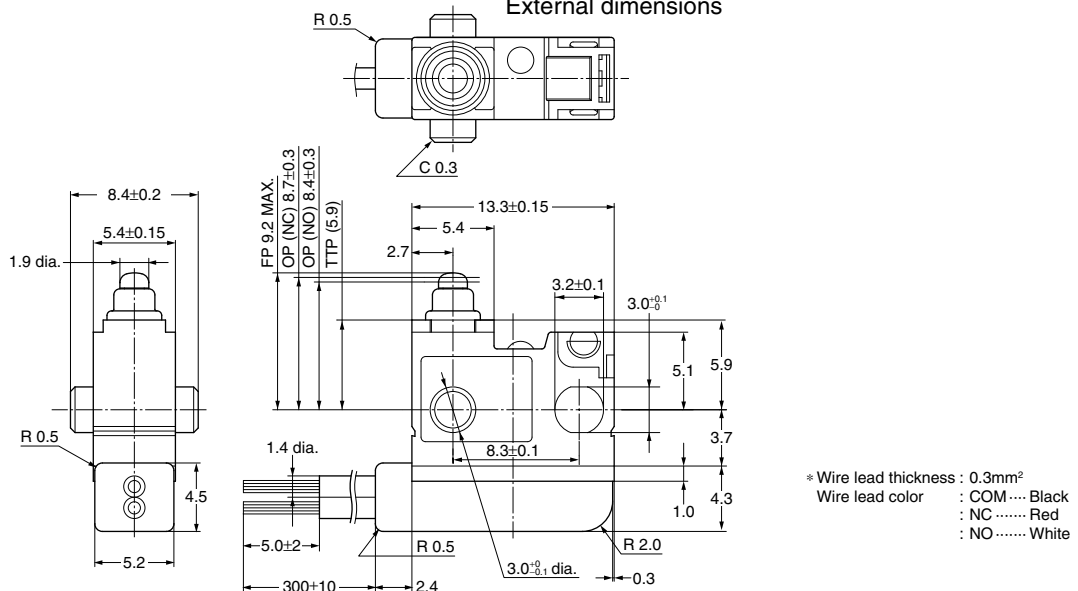



## CAUTIONS FOR USE

### ■ Soldering conditions

The application of excessive heat upon the switch when soldering can cause degradation of switch operation. Therefore, be sure to keep within the conditions given below.

Manual soldering: use soldering irons (max. 350°C, within 3 seconds at each terminal) capable of temperature adjustment. This is to prevent deterioration due to soldering heat. Care should be taken not to apply force to the terminals during soldering.

(More than one second interval is required to apply heat at each terminal.)

### ■ Mounting

Please avoid use in which load would be applied to the sides (hatch part (both sides) shown below) of the switch in the direction indicated by the arrows. This could cause erroneous operation. Also, when using a metal installation board, please make allowance for burr direction designation and burr suppressing, etc., so that the burr side will not be on the switch installation side.

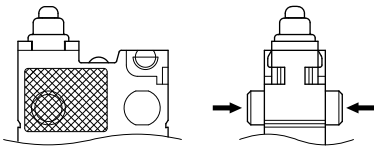

1) To secure the switch, please use an M3 small screw on a flat surface and tighten using a maximum torque of 0.29 N·m. It is recommended that both flat metal washer and spring washers be used with the screws and adhesive be applied to lock the screws to prevent loosening of the screws. Please make sure not to apply adhesive onto the moving parts.

2) Be sure to maintain adequate insulating clearance between each terminal and ground.

3) Although it is possible to directly operate the pin plunger type from the lateral direction, please consult us if doing so.

4) After mounting please make sure no tensile load will be applied to the switch terminals.

5) Range of possible use: Please set the operation position to within the ranges in the following table so that there is sufficient insulation distance and to maintain contact reliability.

Actuator	Plunger/lever free	
	From mounting boss and hole center line	From standoff
Pin plunger	>9.2 mm	>13.4 mm
Leaf lever	>10.7 mm	>14.9 mm
Simulated leaf lever	>13.5 mm	>17.7 mm

Actuator	Plunger/Lever pushed	
	From mounting boss and hole center line	From standoff
Pin plunger	7.8 to 5.9 mm	12.0 to 10.1 mm
Leaf lever	8.4 to 6.2 mm	12.6 to 10.4 mm
Simulated leaf lever	11.1 to 8.7 mm	15.3 to 12.9 mm

6) PC board terminal type should be used if the products are to be soldered on the PC board. Solder terminal type is not for soldering on PC board.

### ■ Cautions regarding the circuit

1) In order to prevent malfunction in set devices caused by bounce and chattering during the ON-OFF switch operation, please verify the validity of the circuit under actual operating conditions and temperature range.

2) When switching inductive loads (relays, solenoids, buzzers, etc.), an arc absorbing circuit is recommended to protect the contacts.

### ■ Please verify under actual conditions.

Please be sure to conduct quality verification under actual operating conditions in order to increase reliability during actual use.

### ■ Selection of switch

Please make your selection so that there will be no problems even if the operating characteristics vary up to ±20% from the standard values.

### ■ Oil-proof and chemical-proof characteristics

The rubber cap swells when exposed to oil and chemicals. The extent of swelling will vary widely depending on the type and amount of oil and chemicals.

Check with the actual oil or chemicals used. In particular, be aware that solvents such as freon, chlorine, and toluene cannot be used.

### ■ Environment

1) Although continuous operation of the switch is possible within the range of ambient temperature (humidity), as the humidity range differs depending on the ambient temperature, the humidity range indicated below should be used. Continuous use near the limit of the range should be avoided.

2) This humidity range does not guarantee permanent performance.

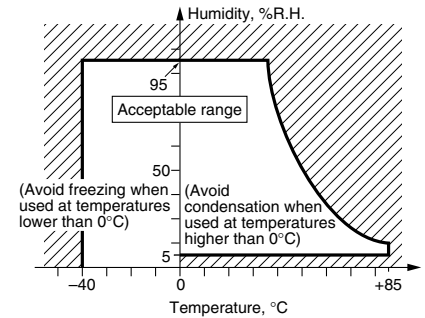

### ■ Other

1) Please remember that this switch cannot be used under water. Also, please be warned that switching and sudden temperature changes with the presence of water droplets can cause seepage into the switch.

2) Keep away from environments where silicon based adhesives, oil or grease are present as faulty contacts may result from silicon oxide. Do not use in areas where flammable or explosive gases from gasoline and thinner, etc., may be present.

3) When using the lever type, please be careful not to apply unreasonable load from the reverse or lateral directions of operation.

4) Do not exceed the total travel position (TTP) and press the actuator. This could cause operation failure. Also, when switching at high speed or under shock even within the operation limit, the working life may decrease. Therefore, please be sure to verify the quality under actual conditions of use.

5) Please make considerations so that the switch does not become the stopper for the moving part.

6) Please do not pull wire leads constantly.

## X-ON Electronics

Largest Supplier of Electrical and Electronic Components

*Click to view similar products for [Basic / Snap Action Switches](#) category:*

*Click to view products by [Panasonic](#) manufacturer:*

Other Similar products are found below :

[83228001](#) [01.098.1358.1](#) [602EN1-6B](#) [602EN532](#) [602EN535-RB](#) [602HE5-RB1](#) [604HE162](#) [604HE223-6B](#) [624HE17-RB](#) [6HM89](#) [6PA78-JM](#)  
[6SE1](#) [6SX1-H58](#) [70500840](#) [MBD5B1](#) [MBH2731](#) [73-316-0012](#) [79211759](#) [79211923](#) [79218589](#) [7AS12](#) [ML-1155](#) [ML-1376](#) [831010C3.0](#)  
[831060C3.TL](#) [831090C2.EL](#) [83131904](#) [84212012](#) [8AS239](#) [8HM73-3](#) [903VB1-PG](#) [914CE1-6G](#) [PL-100](#) [11SM1077-H4](#) [11SM1077-H58](#)  
[11SM1-TN107](#) [11SM405](#) [11SM703-T](#) [11SM8423-H2](#) [11SX37-T](#) [11SX48-H58](#) [11SX55-H58](#) [11SM2442-T](#) [11SM76-T](#) [11SM77-H58](#)  
[11SM77-T](#) [11SM863-T](#) [11SM866](#) [11SX47-H58](#) [A7CN-1M-1-LEFT](#)