

FEATURES

- Max. propagation delay of 1.4ns
- IEE min. of -70mA
- Industry standard 100K ECL levels
- Extended supply voltage option:
VEE = -4.2V to -5.5V
- Differential outputs
- Voltage and temperature compensation for improved noise immunity
- Internal 75kΩ input pull-down resistors
- Twice as fast as Fairchild's 324
- Function and pinout compatible with Fairchild F100K
- Available in 28-pin PLCC package

DESCRIPTION

The SY100S324 is a hex translator designed to convert TTL logic levels to 100K ECL levels. The inputs are TTL compatible with differential outputs that can either be used as an inverting/non-inverting translator or as differential line drivers. A common Enable (E), when LOW, holds all inverting outputs HIGH and holds all non-inverting outputs LOW.

When used in the differential mode, due to its high common mode rejection, it overcomes voltage gradients between the TTL and ECL ground systems. The VEE and VTTL power may be applied in either order.

BLOCK DIAGRAM

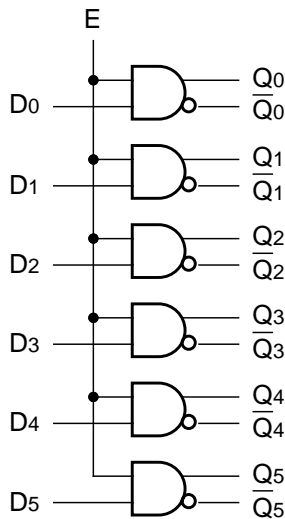

PIN NAMES

Pin	Function
D0-D5	Data Inputs
E	Enable Inputs
Q0-Q5	Data Outputs
$\overline{Q0}-\overline{Q5}$	Complementary Data Outputs
VEES	VEE Substrate
VTTL	TTL Vcc Power Supply
VCCA	Vcco for ECL Outputs

PACKAGE/ORDERING INFORMATION

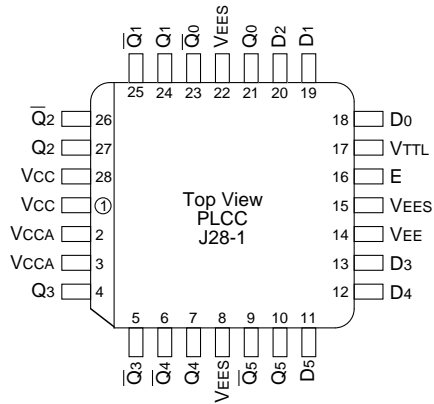

28-Pin PLCC (J28-1)

Ordering Information

Part Number	Package Type	Operating Range	Package Marking	Lead Finish
SY100S324JC	J28-1	Commercial	SY100S324JC	Sn-Pb
SY100S324JCTR ⁽¹⁾	J28-1	Commercial	SY100S324JC	Sn-Pb
SY100S324JY ⁽²⁾	J28-1	Industrial	SY100S324JY with Pb-Free bar-line indicator	Matte-Tin
SY100S324JYTR ^(1, 2)	J28-1	Industrial	SY100S324JY with Pb-Free bar-line indicator	Matte-Tin

Notes:

1. Tape and Reel.
2. Pb-Free package is recommended for new designs.

DC ELECTRICAL CHARACTERISTICS

$V_{EE} = -4.2V$ to $-5.5V$ unless otherwise specified, $V_{CC} = V_{CCA} = GND$, $V_{TTL} = +4.5V$ to $+5.5V$

Symbol	Parameter	Min.	Sim.	Max.	Unit	Condition
VOH	Output HIGH Voltage	-1025	-986	-880	mV	$V_{IN} = V_{IH}$ (Max.)
VOL	Output LOW Voltage	-1810	-1674	-1620	mV	$V_{IN} = V_{IL}$ (Min.)
VOHC	Output HIGH Voltage	-1035	—	—	mV	$V_{IN} = V_{IH}$ (Min.)
VOLC	Output LOW Voltage	—	—	-1610	mV	$V_{IN} = V_{IL}$ (Max.)
V _{IH}	Input HIGH Voltage	2.0	—	5.0	V	Guaranteed HIGH Signal for All Inputs
V _{IL}	Input LOW Voltage	0	—	0.8	V	Guaranteed LOW Signal for All Inputs
V _{CD}	Input Clamp Diode Voltage	—	—	-1.5	V	$I_{IN} = -10mA$
I _{IH}	Input HIGH Current Data Enable	— —	— —	20 120	μA	$V_{IN} = +2.4V$ All Other Inputs $V_{IN} = GND$
I _{IH}	Input HIGH Current Breakdown Test, All Inputs	—	—	1.0	mA	$V_{IN} = +5.5V$, $V_{TTL} = Max.$, All Other Inputs $V_{IN} = GND$
I _{IL}	Input LOW Current Data Enable	-1.2 -6.7	— —	— —	mA	$V_{IN} = +0.4V$ All Other Inputs $V_{IN} = V_{IH}$
I _{EE}	V _{EE} Power Supply Current	-70	-45	-28	mA	All Inputs $V_{IN} = +4.0V$
I _{TTL}	V _{TTL} Power Supply Current	—	25	35	mA	All Inputs $V_{IN} = GND$

AC ELECTRICAL CHARACTERISTICS

$V_{EE} = -4.2V$ to $-5.5V$ unless otherwise specified, $V_{CC} = V_{CCA} = GND$, $V_{TTL} = +4.5V$ to $+5.5V$

Symbol	Parameter	Min.	Typ.	Max.	Unit	Condition
t _{PLH} t _{PHL}	Propagation Delay Data and Enable to Output	400	850	1400	ps	See Switching Wave Form Figures
t _{TLH} t _{THL}	Transition Time 20% to 80%, 80% to 20%	350	—	1700	ps	

SWITCHING WAVEFORM

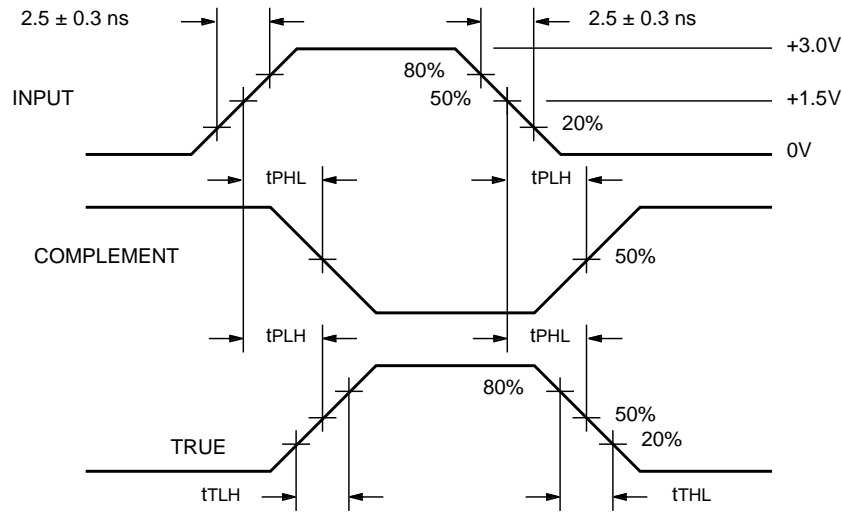

Figure 1. Propagation Delay and Transition Times

Note:

$V_{EE} = -4.2V$ to $-5.5V$ unless otherwise specified, $V_{CC} = V_{CCA} = GND$, $V_{TTL} = +4.5V$ to $+5.5V$

TEST CIRCUIT

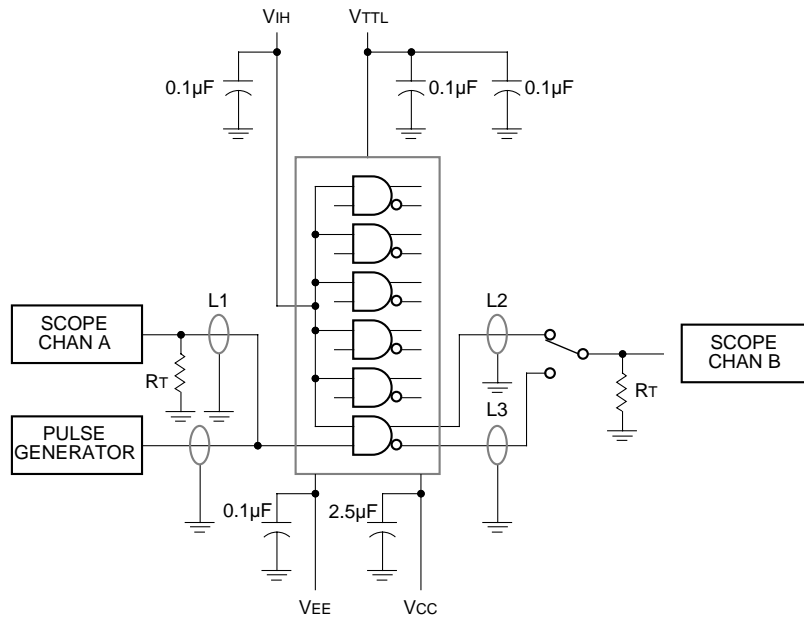
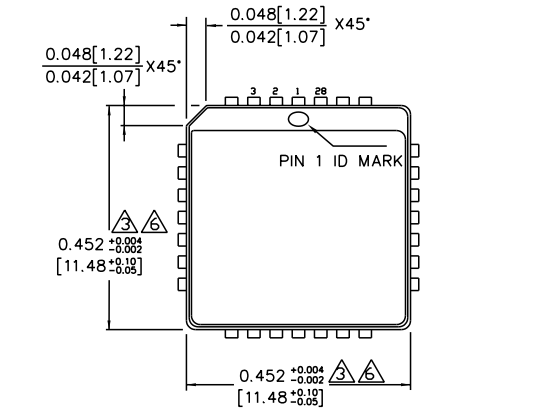

Figure 2. AC Test Circuit

Notes:

- $V_{CC}, V_{CCA} = +2V, V_{EE} = -2.5V, V_{TTL} = +7.0V, V_{IH} = +6.0V$
- $L1, L2$ and $L3 =$ equal length 50Ω impedance lines
- $R_T = 50\Omega$ terminator internal to scope
- Decoupling 0.1µF from GND to V_{CC}, V_{EE} and V_{TTL}
- All unused outputs are loaded with 50Ω to GND
- $C_L =$ Fixture and stray capacitance $\leq 3pF$

28-PIN PLCC (J28-1)



TOP VIEW

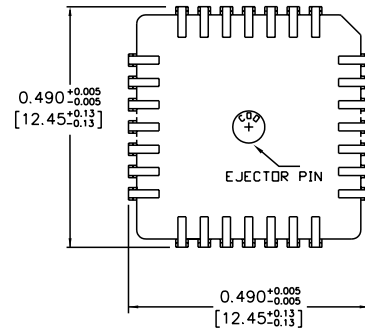

BOTTOM VIEW

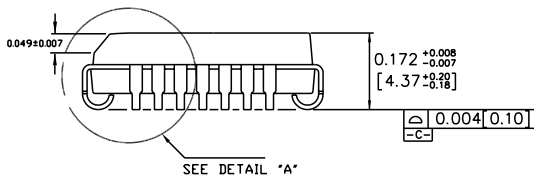

SIDE VIEW

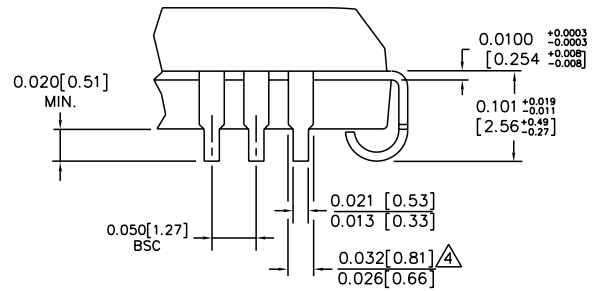

DETAIL "A"

NOTES:

1. DIMENSIONS ARE IN INCHES [MM].
2. CONTROLLING DIMENSION: INCHES.
3. DIMENSION DOES NOT INCLUDE MOLD FLASH OR PROTRUSIONS, EITHER OF WHICH SHALL NOT EXCEED 0.008 [0.203].
4. LEAD DIMENSION DOES NOT INCLUDE DAMBAR PROTRUSION.
5. MAXIMUM AND MINIMUM SPECIFICATIONS ARE INDICATED AS FOLLOWS: MAX/MIN
6. PACKAGE TOP DIMENSION MAY BE SLIGHTLY SMALLER THAN BOTTOM DIMENSION.

Rev. A

MICREL, INC. 2180 FORTUNE DRIVE SAN JOSE, CA 95131 USA

TEL + 1 (408) 944-0800 FAX + 1 (408) 474-1000 WEB <http://www.micrel.com>

The information furnished by Micrel in this data sheet is believed to be accurate and reliable. However, no responsibility is assumed by Micrel for its use. Micrel reserves the right to change circuitry and specifications at any time without notification to the customer.

Micrel Products are not designed or authorized for use as components in life support appliances, devices or systems where malfunction of a product can reasonably be expected to result in personal injury. Life support devices or systems are devices or systems that (a) are intended for surgical implant into the body or (b) support or sustain life, and whose failure to perform can be reasonably expected to result in a significant injury to the user. A Purchaser's use or sale of Micrel Products for use in life support appliances, devices or systems is at Purchaser's own risk and Purchaser agrees to fully indemnify Micrel for any damages resulting from such use or sale.

© 2006 Micrel, Incorporated.

X-ON Electronics

Largest Supplier of Electrical and Electronic Components

Click to view similar products for [Translation - Voltage Levels](#) category:

Click to view products by [Micrel](#) manufacturer:

Other Similar products are found below :

[NLJVHC1GT08DFT2G](#) [NLSX4373DMR2G](#) [NLSX5012MUTAG](#) [HV583GA-G](#) [MC10H641FNR2G](#) [NLSX0102FCT1G](#) [NLSX0102FCT2G](#)
[NLSX4302EBMUTCG](#) [NLVSX4373DR2G](#) [PCA9306FMUTAG](#) [SY10H351JZ](#) [MC100EPT622MNG](#) [MAX9374AEKA+T](#) [MAX3378EETD+](#)
[MAX34405BEZT+](#) [NLSX3014MUTAG](#) [NVT4556BUKZ](#) [NLSV4T244EMUTAG](#) [NLSX5011MUTCG](#) [NLV9306USG](#)
[NLVSX4014MUTAG](#) [MAX34405BEZT+T](#) [NLSV4T3144MUTAG](#) [NSV12200LT1G](#) [NLVSX4373MUTAG](#) [NB3U23CMNTAG](#)
[MAX3371ELT+T](#) [MAX3008EUP+T](#) [NLVPCA9306AMUTCG](#) [NLSX3013BFCT1G](#) [MAX9378EUA+T](#) [NLV7WBD3125USG](#)
[NLV14504BDTG](#) [NLSX3012DMR2G](#) [NLSX5012DR2G](#) [MAX3391EEUD+T](#) [MAX3379EETD+](#) [PI4ULS3V4857GEAEX](#)
[MAX3391EEBC+T](#) [MAX14842ATE+T](#) [74AVCH1T45FZ4-7](#) [CLVC16T245MDGGREP](#) [HEF4104BT](#) [TC74LCX16245\(EL,F\)](#)
[MC10H124FNG](#) [CAVCB164245MDGGREP](#) [7WBD383USG](#) [NVT2001GM,115](#) [CLVC8T245MRHLTEP](#) [74LVC1G175GS,132](#)