

FEATURES

- 450ps max. Propagation Delay
- Extended 100E VEE range of -4.2V to -5.5V
- VBB output for single-ended reception
- Fully compatible with industry standard 10KH, 100K I/O levels
- Internal 75KΩ input pulldown resistors
- Fully compatible with Motorola MC10E/100E116
- Available in 28-pin PLCC package

BLOCK DIAGRAM

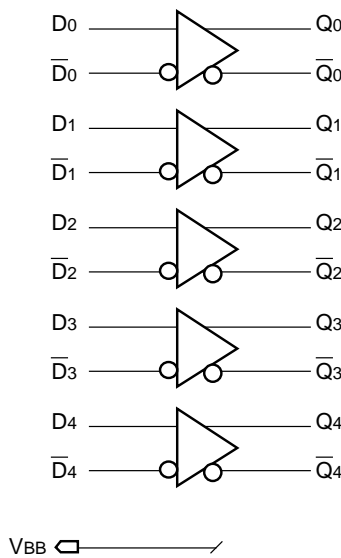

DESCRIPTION

The SY10/100E116 are quint differential line receivers designed for use in new, high-performance ECL systems. These devices have emitter-follower outputs and an internally generated reference supply (VBB) for single-ended reception.

Active current sources combined with Micrel's ASSET™ technology provide the receivers with excellent common mode noise rejection.

The receiver design features clamp circuitry to cause a defined output state if both the inverting and non-inverting inputs are left open; in this case the Q output goes LOW, while the Q-bar output goes HIGH.

If both inverting and non-inverting inputs are at equal potential, the receiver does *not* go to a defined state, but rather shares current in normal differential amplifier fashion, producing output voltage levels midway between HIGH and LOW.

The VBB output is intended for use as a reference voltage for single-ended reception of ECL signals to that device only. When using VBB for this purpose, it is recommended that VBB is decoupled to VCC via a 0.01 μF capacitor.

For higher bandwidth, please refer to the SY10/100E416 device.

PIN NAMES

Pin	Function
D0, D̄0-D4, D̄4	Differential Input Pairs
Q0, Q̄0-Q4, Q̄4	Differential Output Pairs
VBB	Reference Voltage Output
Vcco	Vcc to Output

PACKAGE/ORDERING INFORMATION

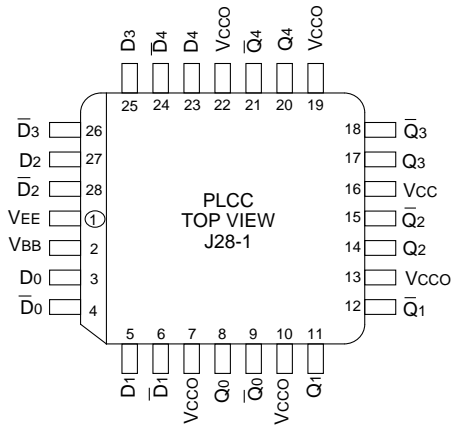

28-Pin PLCC (J28-1)

Ordering Information⁽¹⁾

Part Number	Package Type	Operating Range	Package Marking	Lead Finish
SY10E116JI	J28-1	Industrial	SY10E116JI	Sn-Pb
SY10E116JITR ⁽²⁾	J28-1	Industrial	SY10E116JI	Sn-Pb
SY100E116JI	J28-1	Industrial	SY100E116JI	Sn-Pb
SY100E116JITR ⁽²⁾	J28-1	Industrial	SY100E116JI	Sn-Pb
SY10E116JC	J28-1	Commercial	SY10E116JC	Sn-Pb
SY10E116JCTR ⁽²⁾	J28-1	Commercial	SY10E116JC	Sn-Pb
SY100E116JC	J28-1	Commercial	SY100E116JC	Sn-Pb
SY100E116JCTR ⁽²⁾	J28-1	Commercial	SY100E116JC	Sn-Pb
SY10E116JY ⁽³⁾	J28-1	Industrial	SY10E116JY with Pb-Free bar-line indicator	Matte-Sn
SY10E116JYTR ^(2, 3)	J28-1	Industrial	SY10E116JY with Pb-Free bar-line indicator	Matte-Sn
SY100E116JY ⁽³⁾	J28-1	Industrial	SY100E116JY with Pb-Free bar-line indicator	Matte-Sn
SY100E116JYTR ^(2, 3)	J28-1	Industrial	SY100E116JY with Pb-Free bar-line indicator	Matte-Sn

Notes:

1. Contact factory for die availability. Dice are guaranteed at T_A = 25°C, DC Electricals only.
2. Tape and Reel.
3. Pb-Free package is recommended for new designs.

LOGIC EQUATION

$$Q_n = D_n$$

DC ELECTRICAL CHARACTERISTICSV_{EE} = V_{EE}(Min.) to V_{EE}(Max.); V_{CC} = V_{CCO} = GND

Symbol	Parameter	T _A = -40°C			T _A = 0°C			T _A = +25°C			T _A = +85°C			Unit	
		Min.	Typ.	Max.	Min.	Typ.	Max.	Min.	Typ.	Max.	Min.	Typ.	Max.		
V _{BB}	Output Reference Voltage	10E	-1.43	—	-1.30	-1.38	—	-1.27	-1.35	—	-1.25	-1.31	—	-1.19	V
		100E	-1.43	—	-1.26	-1.38	—	-1.26	-1.38	—	-1.26	-1.38	—	-1.26	
I _{IH}	Input HIGH Current	—	—	200	—	—	200	—	—	200	—	—	200	μA	
I _{EE}	Power Supply Current	10E	—	29	35	—	29	35	—	29	35	—	29	35	mA
		100E	—	29	35	—	29	35	—	29	35	—	33	40	
V _{PP} (DC)	Input Sensitivity ⁽¹⁾	150	—	—	150	—	—	150	—	—	150	—	—	mV	
V _{CMR}	Common Mode Range ⁽²⁾	-2.0	—	-0.6	-2.0	—	-0.6	-2.0	—	-0.6	-2.0	—	-0.6	V	

Notes:

- V_{PP} is the minimum differential input voltage required to assure full ECL levels are present at the outputs.
- V_{CMR} is referenced to the most positive side of the differential input signal. Normal operation is obtained when the "HIGH" input is within the V_{CMR} range and the input swing is greater than V_{PP} (min.) and <1V.

AC ELECTRICAL CHARACTERISTICSV_{EE} = V_{EE}(Min.) to V_{EE}(Max.); V_{CC} = V_{CCO} = GND

Symbol	Parameter	T _A = -40°C			T _A = 0°C			T _A = +25°C			T _A = +85°C			Unit
		Min.	Typ.	Max.	Min.	Typ.	Max.	Min.	Typ.	Max.	Min.	Typ.	Max.	
t _{PD}	Propagation Delay to Output D D (S.E.)	150	300	500	200	300	450	200	300	450	200	300	450	ps
		150	300	550	150	300	500	150	300	500	150	300	500	
V _{PP} (DC)	Input Sensitivity ⁽¹⁾	150	—	150	150	—	—	150	—	—	150	—	—	mV
t _{skew}	Within-Device Skew ⁽²⁾ D _n to Q _n , \bar{Q}_n	—	50	—	—	50	—	—	50	—	—	50	—	ps
t _{skew}	Duty Cycle Skew ⁽³⁾ t _{PLH} - t _{PHL}	—	±10	—	—	±10	—	—	±10	—	—	±10	—	ps
t _r t _f	Rise/Fall Time 20% to 80%	250	375	625	275	375	575	275	375	575	275	375	575	ps

Notes:

- Minimum input swing for which AC parameters are guaranteed.
- Within-device skew is defined as identical transitions on similar paths through a device.
- Duty cycle skew is defined only for differential operation when the delays are measured from the cross point of the inputs to the cross point of the outputs.

28-PIN PLCC (J28-1)



Rev. 03

MICREL, INC. 2180 FORTUNE DRIVE SAN JOSE, CA 95131 USA

TEL + 1 (408) 944-0800 FAX + 1 (408) 474-1000 WEB <http://www.micrel.com>

The information furnished by Micrel in this data sheet is believed to be accurate and reliable. However, no responsibility is assumed by Micrel for its use. Micrel reserves the right to change circuitry and specifications at any time without notification to the customer.

Micrel Products are not designed or authorized for use as components in life support appliances, devices or systems where malfunction of a product can reasonably be expected to result in personal injury. Life support devices or systems are devices or systems that (a) are intended for surgical implant into the body or (b) support or sustain life, and whose failure to perform can be reasonably expected to result in a significant injury to the user. A Purchaser's use or sale of Micrel Products for use in life support appliances, devices or systems is at Purchaser's own risk and Purchaser agrees to fully indemnify Micrel for any damages resulting from such use or sale.

© 2006 Micrel, Incorporated.

X-ON Electronics

Largest Supplier of Electrical and Electronic Components

Click to view similar products for [Buffers & Line Drivers](#) category:

Click to view products by [Microchip](#) manufacturer:

Other Similar products are found below :

[5962-9217601MSA](#) [634810D](#) [875140G](#) [HEF4022BP](#) [HEF4043BP](#) [NL17SG125DFT2G](#) [NL17SZ126P5T5G](#) [NLU1GT126CMUTCG](#)
[NLU3G16AMX1TCG](#) [NLV27WZ125USG](#) [MC74HCT365ADTR2G](#) [BCM6306KMLG](#) [54FCT240CTDB](#) [Le87401NQC](#) [Le87402MQC](#)
[028192B](#) [042140C](#) [051117G](#) [070519XB](#) [065312DB](#) [091056E](#) [098456D](#) [NL17SG07DFT2G](#) [NL17SG17DFT2G](#) [NL17SG34DFT2G](#)
[NL17SZ07P5T5G](#) [NL17SZ125P5T5G](#) [NLU1GT126AMUTCG](#) [NLV27WZ16DFT2G](#) [5962-8982101PA](#) [5962-9052201PA](#) [74LVC07ADR2G](#)
[MC74VHC1G125DFT1G](#) [NL17SH17P5T5G](#) [NL17SZ125CMUTCG](#) [NLV17SZ07DFT2G](#) [NLV37WZ17USG](#) [NLVHCT244ADTR2G](#)
[NC7WZ17FHX](#) [74HCT126T14-13](#) [NL17SH125P5T5G](#) [NLV14049UBDTR2G](#) [NLV37WZ07USG](#) [74VHC541FT\(BE\)](#) [RHFAC244K1](#)
[74LVC1G17FW4-7](#) [74LVC1G126FZ4-7](#) [BCM6302KMLG](#) [74LVC1G07FZ4-7](#) [74LVC1G125FW4-7](#)