

■ General Description

The AME8805/8813 family of positive, linear regulators feature low quiescent current (30 μ A typ.) with low drop-out voltage, making them ideal for battery applications. The space-saving SOT-89, SOT-223 and SOT-23 packages are attractive for "Pocket" and "Hand Held" applications.

These rugged devices have both Thermal Shutdown, and Current Fold-back to prevent device failure under the "Worst" operating conditions.

The AME8805/8813 is stable with an output capacitance of 2.2 μ F or greater.

■ Features

- Very Low Dropout Voltage
- Guaranteed 600mA Output
- Accurate to within 1.5%
- 30 μ A Quiescent Current
- Over-Temperature Shutdown
- Current Limiting
- Short Circuit Current Fold-back
- Space-Saving SOT-89, SOT-223, SOT-23
- Factory Pre-set Output Voltages
- Low Temperature Coefficient
- Green Products Meet RoHS Standards

■ Applications

- Instrumentation
- Portable Electronics
- Wireless Devices
- Cordless Phones
- PC Peripherals
- Battery Powered Widgets
- Electronic Scales

■ Functional Block Diagram

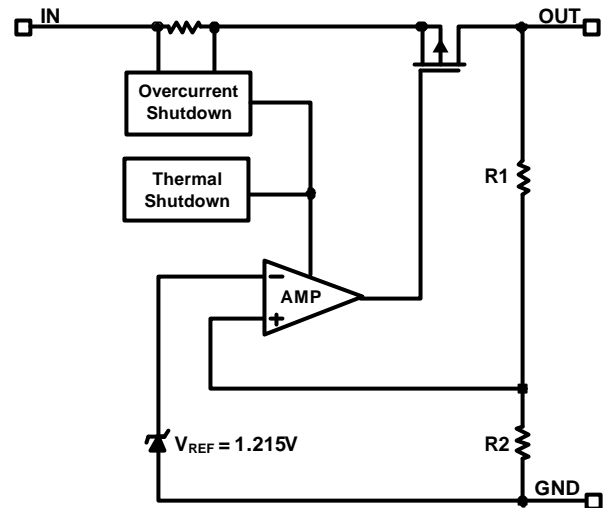

■ Typical Application

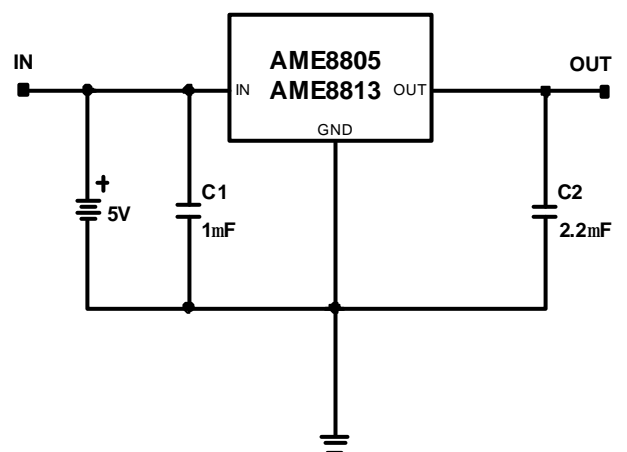

■ Pin Configuration



AME8805
 1. GND
 2. IN (TAB)
 3. OUT

*** Die Attach:
 Non-Conductive Epoxy**

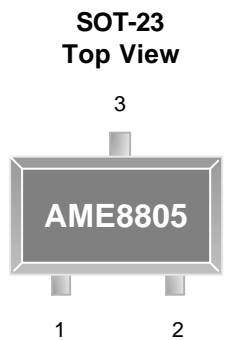

AME8805
 1. IN
 2. GND (TAB)
 3. OUT

*** Die Attach:
 Conductive Epoxy**



AME8805
 1. IN
 2. OUT
 3. GND

*** Die Attach:
 Conductive Epoxy**

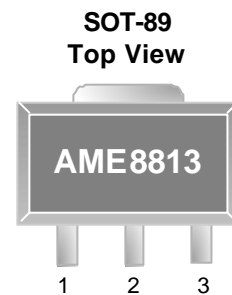

AME8813
 1. IN
 2. GND (TAB)
 3. OUT

*** Die Attach:
 Conductive Epoxy**



■ Ordering Information

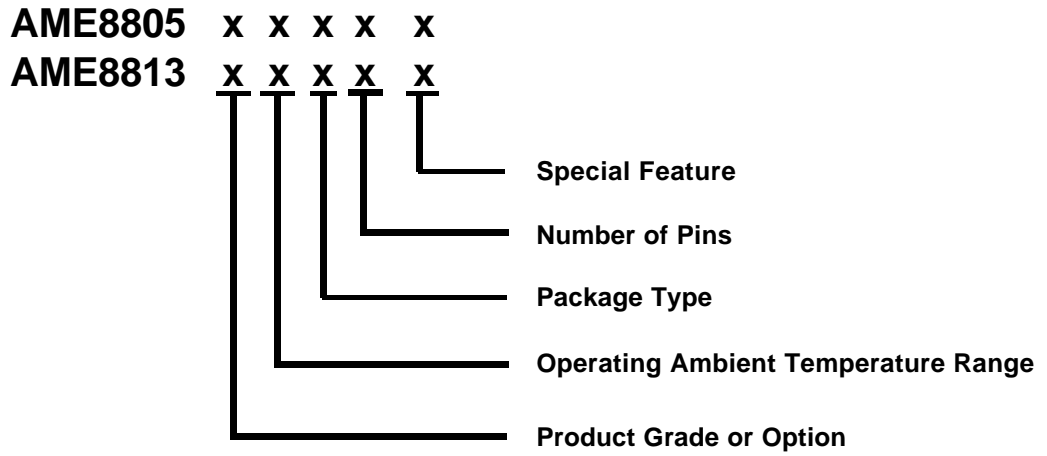

Product Grade or Option	Operating Ambient Temperature Range	Package Type	Number of Pins	Special Feature
A: 3.3V 1: 1.3V B: 3.0V 2: 2.0V C: 2.8V 3: 4.2V D: 2.5V 4: 4.0V E: 3.8V F: 3.6V G: 3.5V H: 2.7V I: 3.4V J: 2.85V K: 3.7V L: 1.5V M: 1.8V N: 2.9V O: 3.1V P: 4.1V Q: 4.75V R: 2.65V S: 5.0V U: 3.2V V: 3.15V W: 2.3V Y: 1.9V Z: 1.7V	E: -40°C to +85°C	F: SOT-89 G: SOT-223 E: SOT-2X	T: 3	Z: Lead Free

■ Ordering Information

Part Number	Marking*	Output Voltage	Package	Operating Ambient Temperature Range
AME8805AEFT	A8805 AEFww	3.3V	SOT-89	- 40°C to +85°C
AME8805AEFTZ	A8805 AEFww	3.3V	SOT-89	- 40°C to +85°C
AME8805BEFT	A8805 BEFww	3.0V	SOT-89	- 40°C to +85°C
AME8805BEFTZ	A8805 BEFww	3.0V	SOT-89	- 40°C to +85°C
AME8805CEFT	A8805 CEFww	2.8V	SOT-89	- 40°C to +85°C
AME8805CEFTZ	A8805 CEFww	2.8V	SOT-89	- 40°C to +85°C
AME8805DEFT	A8805 DEFww	2.5V	SOT-89	- 40°C to +85°C
AME8805DEFTZ	A8805 DEFww	2.5V	SOT-89	- 40°C to +85°C
AME8805EEFT	A8805 EEFww	3.8V	SOT-89	- 40°C to +85°C
AME8805EEFTZ	A8805 EEFww	3.8V	SOT-89	- 40°C to +85°C
AME8805FEFT	A8805 FEFww	3.6V	SOT-89	- 40°C to +85°C
AME8805FEFTZ	A8805 FEFww	3.6V	SOT-89	- 40°C to +85°C
AME8805GEFT	A8805 GEFww	3.5V	SOT-89	- 40°C to +85°C
AME8805GEFTZ	A8805 GEFww	3.5V	SOT-89	- 40°C to +85°C
AME8805HEFT	A8805 HEFww	2.7V	SOT-89	- 40°C to +85°C
AME8805HEFTZ	A8805 HEFww	2.7V	SOT-89	- 40°C to +85°C
AME8805IEFT	A8805 IEFww	3.4V	SOT-89	- 40°C to +85°C
AME8805IEFTZ	A8805 IEFww	3.4V	SOT-89	- 40°C to +85°C
AME8805JEFT	A8805 JEFww	2.85V	SOT-89	- 40°C to +85°C
AME8805JEFTZ	A8805 JEFww	2.85V	SOT-89	- 40°C to +85°C

Note: ww & yww represent the date code and pls refer to the Date Code Rule on Package Dimension.

* A line on top of the first letter represents lead free plating such as A8805.

Please consult AME sales office or authorized Rep./Distributor for output voltage and package type availability.

■ Ordering Information (contd.)

Part Number	Marking*	Output Voltage	Package	Operating Ambient Temperature Range
AME8805KEFT	A8805 KEFww	3.7V	SOT-89	- 40°C to +85°C
AME8805KEFTZ	A8805 KEFww	3.7V	SOT-89	- 40°C to +85°C
AME8805LEFT	A8805 LEFww	1.5V	SOT-89	- 40°C to +85°C
AME8805LEFTZ	A8805 LEFww	1.5V	SOT-89	- 40°C to +85°C
AME8805MEFT	A8805 MEFww	1.8V	SOT-89	- 40°C to +85°C
AME8805MEFTZ	A8805 MEFww	1.8V	SOT-89	- 40°C to +85°C
AME8805NEFT	A8805 NEFww	2.9V	SOT-89	- 40°C to +85°C
AME8805NEFTZ	A8805 NEFww	2.9V	SOT-89	- 40°C to +85°C
AME8805OEFT	A8805 OEFww	3.1V	SOT-89	- 40°C to +85°C
AME8805OEFTZ	A8805 OEFww	3.1V	SOT-89	- 40°C to +85°C
AME8805YEFT	A8805 YEFww	1.9V	SOT-89	- 40°C to +85°C
AME8805YEFTZ	A8805 YEFww	1.9V	SOT-89	- 40°C to +85°C
AME88052EFT	A8805 2EFww	2.0V	SOT-89	- 40°C to +85°C
AME88052EFTZ	A8805 2EFww	2.0V	SOT-89	- 40°C to +85°C
AME8813AEFTZ	A8813 AEFww	3.3V	SOT-89	- 40°C to +85°C
AME8813SEFTZ	A8813 SEFww	5.0V	SOT-89	- 40°C to +85°C
AME8805AEGT	ADByww	3.3V	SOT-223	- 40°C to +85°C
AME8805AEGTZ	ADByww	3.3V	SOT-223	- 40°C to +85°C
AME8805BEGT	ADCyww	3.0V	SOT-223	- 40°C to +85°C
AME8805BEGTZ	ADCyww	3.0V	SOT-223	- 40°C to +85°C
AME8805CEGT	ADDyww	2.8V	SOT-223	- 40°C to +85°C
AME8805CEGTZ	ADDyww	2.8V	SOT-223	- 40°C to +85°C
AME8805DEGT	ADEyww	2.5V	SOT-223	- 40°C to +85°C

■ Ordering Information (contd.)

Part Number	Marking*	Output Voltage	Package	Operating Ambient Temperature Range
AME8805DEGTZ	ADEyww	2.5V	SOT-223	- 40°C to +85°C
AME8805EEGT	ADFyww	3.8V	SOT-223	- 40°C to +85°C
AME8805EEGTZ	ADFyww	3.8V	SOT-223	- 40°C to +85°C
AME8805GEGT	ADHyww	3.5V	SOT-223	- 40°C to +85°C
AME8805GEGTZ	ADHyww	3.5V	SOT-223	- 40°C to +85°C
AME8805HEGT	AEJyww	2.7V	SOT-223	- 40°C to +85°C
AME8805HEGTZ	AEJyww	2.7V	SOT-223	- 40°C to +85°C
AME8805IEGT	AERyww	3.4V	SOT-223	- 40°C to +85°C
AME8805IEGTZ	AERyww	3.4V	SOT-223	- 40°C to +85°C
AME8805JEGT	AGTyww	2.85V	SOT-223	- 40°C to +85°C
AME8805JEGTZ	AGTyww	2.85V	SOT-223	- 40°C to +85°C
AME8805KEGT	AHVyww	3.7V	SOT-223	- 40°C to +85°C
AME8805KEGTZ	AHVyww	3.7V	SOT-223	- 40°C to +85°C
AME8805LEGT	AJlyww	1.5V	SOT-223	- 40°C to +85°C
AME8805LEGTZ	AJlyww	1.5V	SOT-223	- 40°C to +85°C
AME8805MEGT	AJyww	1.8V	SOT-223	- 40°C to +85°C
AME8805MEGTZ	AJyww	1.8V	SOT-223	- 40°C to +85°C
AME8805NEGT	AKSyww	2.9V	SOT-223	- 40°C to +85°C
AME8805NEGTZ	AKSyww	2.9V	SOT-223	- 40°C to +85°C
AME8805OEGT	AKTyww	3.1V	SOT-223	- 40°C to +85°C
AME8805OEGTZ	AKTyww	3.1V	SOT-223	- 40°C to +85°C
AME8805YEGTZ	BClyww	1.9V	SOT-223	- 40°C to +85°C
AME8805YEGTZ	BClyww	1.9V	SOT-223	- 40°C to +85°C
AME88051EGT	AWLyww	1.3V	SOT-223	- 40°C to +85°C
AME88051EGTZ	AWLyww	1.3V	SOT-223	- 40°C to +85°C
AME8805AEETZ	BTYww	3.3V	SOT-23	- 40°C to +85°C
AME8805MEETZ	BTZww	1.8V	SOT-23	- 40°C to +85°C
AME8813DEFTZ	A8813 DEFww	2.5V	SOT-89	- 40°C to +85°C
AME8805SEFTZ	A8805 SEFww	5.0V	SOT-89	- 40°C to +85°C

■ Absolute Maximum Ratings

Parameter	Maximum	Unit
Input Voltage	-0.3 to +8	V
Output Voltage	-0.3 to $V_{IN} + 0.3$	V
Output Current	$P_D / (V_{IN} - V_{OUT})$	mA
ESD Classification	B*	

Caution: Stress above the listed absolute maximum rating may cause permanent damage to the device.

*HBM B:2000V~3999V

■ Recommended Operating Conditions

Parameter	Symbol	Rating	Unit
Ambient Temperature Range	T_A	- 40 to +85	°C
Junction Temperature Range	T_J	- 40 to +125	°C
Storage Temperature Range	T_{STG}	- 65 to +150	°C

■ Thermal Information

Parameter	Package	Die Attach	Symbol	Maximum	Unit
Thermal Resistance (Junction to Case)	*SOT-89	Conductive Epoxy	θ_{JC}	40	°C / W
		Non-Conductive Epoxy		46	
	*SOT-223	Conductive Epoxy		25	
	**SOT-23	Conductive Epoxy		81	
Thermal Resistance (Junction to Ambient)	SOT-89	Conductive Epoxy	θ_{JA}	180	°C / W
		Non-Conductive Epoxy		180	
	SOT-223	Conductive Epoxy		120	
	SOT-23	Conductive Epoxy		260	
Internal Power Dissipation	SOT-89	Conductive Epoxy	P_D	550	mW
		Non-Conductive Epoxy		550	
	SOT-223	Conductive Epoxy		900	
	SOT-23	Conductive Epoxy		400	
Maximum Junction Temperature				150	°C
Solder Iron(10 Sec)***				350	°C

* Measure θ_{JC} on backside center of tab.

** Measure θ_{JC} on backside center of molding compound if IC has no tab.

*** MIL-STD-202G 210F

■ Electrical Specifications

TA = 25°C unless otherwise noted

Parameter	Symbol	Test Condition	Min	Typ	Max	Units	
Input Voltage	V_{IN}		Note 1		7	V	
Output Voltage Accuracy	V_O	$I_O=1mA$	-1.5		1.5	%	
Dropout Voltage	$V_{DROPOUT}$	$I_O=600mA$ $V_O=V_{O(NOM)}-2.0%$	$1.3V \leq V_{O(NOM)} \leq 1.4V$	See chart	1900	mV	
			$1.4V < V_{O(NOM)} \leq 2.0V$		1400		
			$2.0V < V_{O(NOM)} \leq 2.8V$		800		
			$2.8V < V_{O(NOM)}$		600		
Output Current	I_O	$V_O > 1.2V$	600			mA	
Current Limit	I_{LIM}	$V_O > 1.2V$	600	800		mA	
Short Circuit Current	I_{SC}	$V_O < 0.8V$		300	600	mA	
Quiescent Current	I_Q	$I_O=0mA$		30	50	μA	
Ground Pin Current	I_{GND}	$I_O=1mA$ to 600mA		35		μA	
Line Regulation	REG_{LINE}	$I_O=1mA$ $V_{IN}=V_O+1$ to V_O+2	$1.3V \leq V_O \leq 1.4V$	-0.2		0.2	%
			$1.4V < V_O \leq 2.0V$	-0.15		0.15	
			$2.0V < V_O < 4.0V$	-0.1	0.02	0.1	
			$V_O \geq 4.0V$	-0.4	0.2	0.4	
Load Regulation	REG_{LOAD}	$I_O=1mA$ to 600mA		0.2	1	%	
Over Temperature Shutdown	OTS			150		$^{\circ}C$	
Over Temperature Hysteresis	OTH			30		$^{\circ}C$	
V_O Temperature Coefficient	TC			30		ppm/ $^{\circ}C$	
Power Supply Rejection	PSRR	$I_O=100mA$ $C_O=2.2\mu F$	$f=100Hz$		60	dB	
			$f=1kHz$		50		
			$f=10kHz$		20		
Output Voltage Noise	eN	$f=10Hz$ to 100kHz $I_O=10mA, C_{BYP}=0\mu F$	$C_O=2.2\mu F$		30	μV_{rms}	

 Note1: $V_{IN(MIN)}=V_{OUT}+V_{DROPOUT}$

Note2: To prevent the Short Circuit Current protection feature from being prematurely activated, the input voltage must be applied before a current source load is applied.

■ Detailed Description

The AME8805/8813 family of CMOS regulators contain a PMOS pass transistor, voltage reference, error amplifier, over-current protection, and thermal shutdown.

The P-channel pass transistor receives data from the error amplifier, over-current shutdown, and thermal protection circuits. During normal operation, the error amplifier compares the output voltage to a precision reference. Over-current and Thermal shutdown circuits become active when the junction temperature exceeds 150°C, or the current exceeds 600mA. During thermal shutdown, the output voltage remains low. Normal operation is restored when the junction temperature drops below 120°C.

The AME8805/8813 switches from voltage mode to current mode when the load exceeds the rated output current. This prevents over-stress. The AME8805/8813 also incorporates current foldback to reduce power dissipation when the output is short circuited. This feature becomes active when the output drops below 0.8 volts, and reduces the current flow by 65%. Full current is restored when the voltage exceeds 0.8 volts.

■ External Capacitors

The AME8805/8813 is stable with an output capacitor to ground of 2.2 μ F or greater. Ceramic capacitors have the lowest ESR, and will offer the best AC performance. Conversely, Aluminum Electrolytic capacitors exhibit the highest ESR, resulting in the poorest AC response. Unfortunately, large value ceramic capacitors are comparatively expensive. One option is to parallel a 0.1 μ F ceramic capacitor with a 10 μ F Aluminum Electrolytic. The benefit is low ESR, high capacitance, and low overall cost.

A second capacitor is recommended between the input and ground to stabilize V_{in} . The input capacitor should be at least 0.1 μ F to have a beneficial effect.

All capacitors should be placed in close proximity to the pins. A "Quiet" ground termination is desirable. This can be achieved with a "Star" connection.

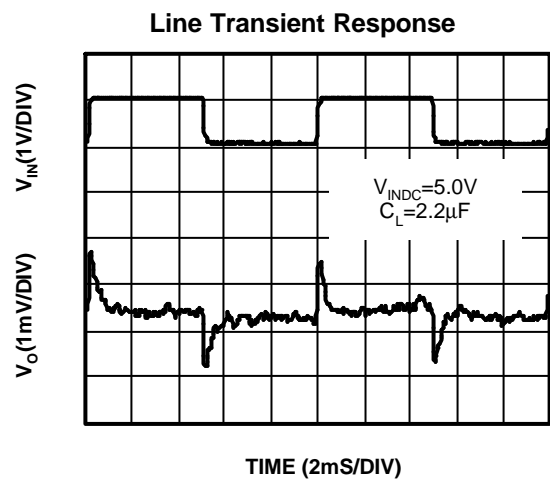
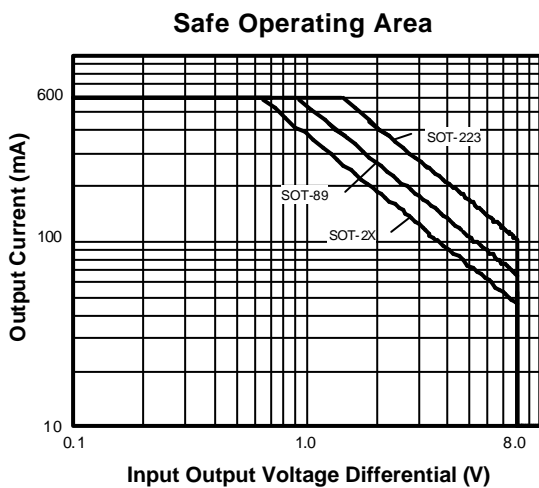
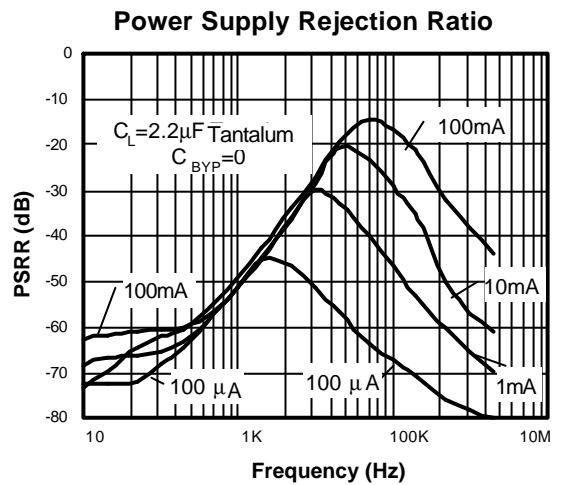
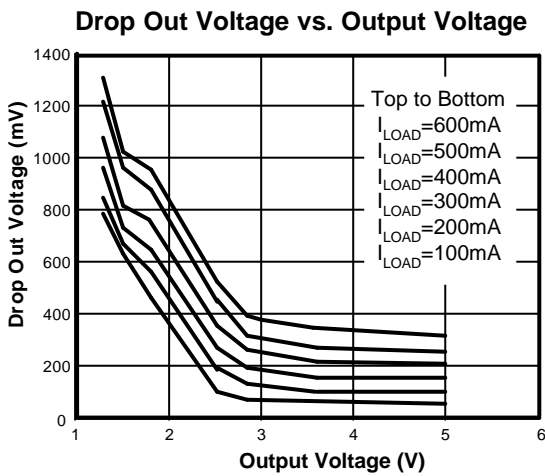
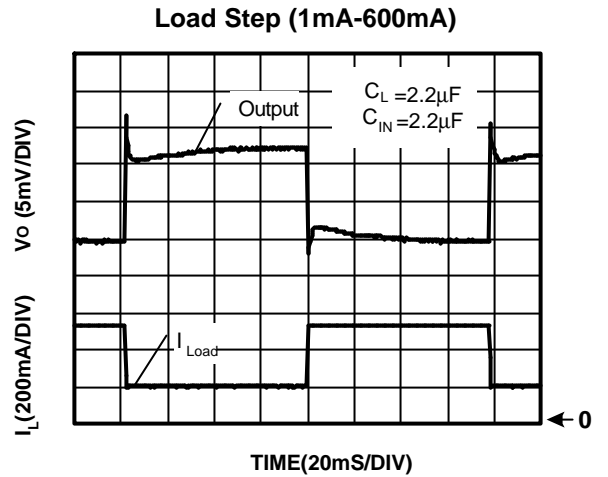
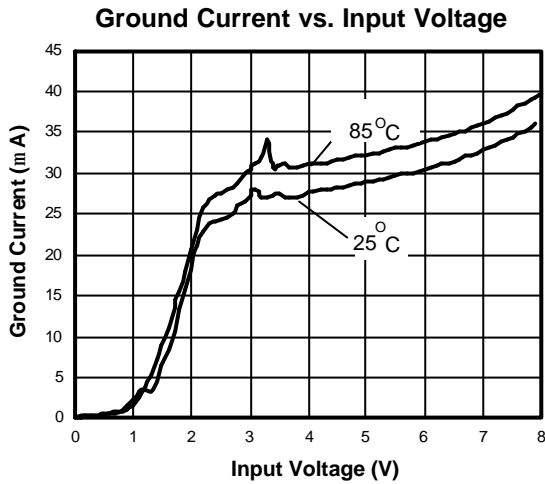
■ Characterization Curve

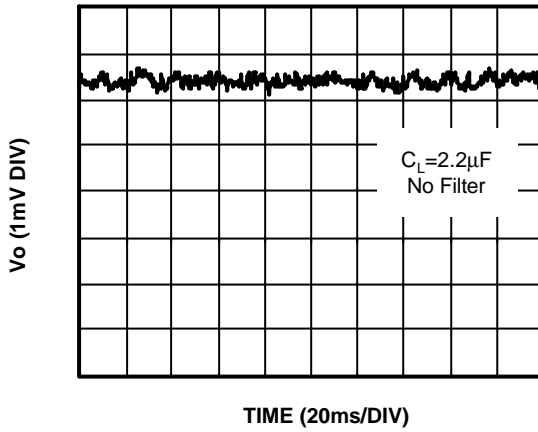
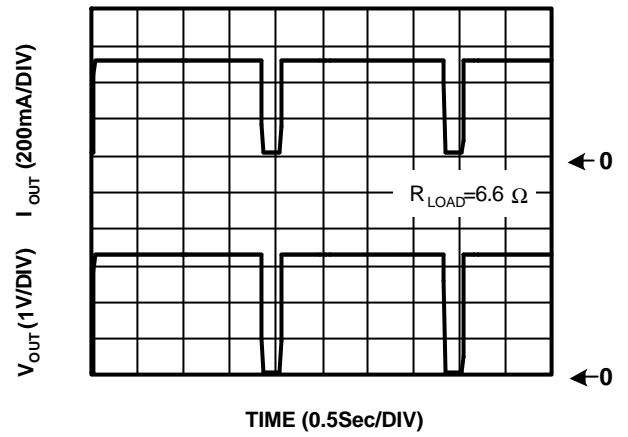
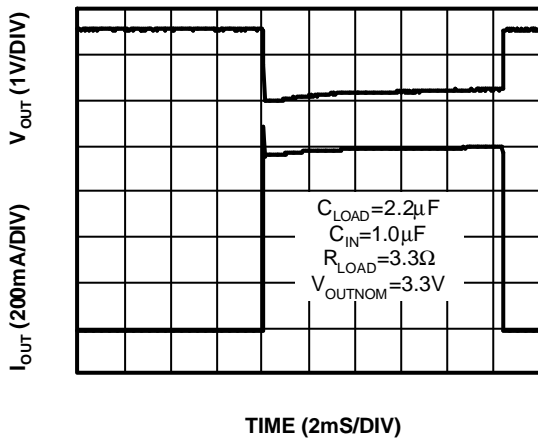
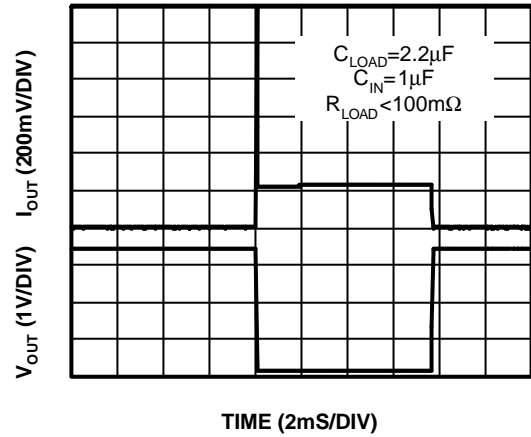
■ Characterization Curve (Contd.)
Noise Measurement

Overtemperature Shutdown

Current Limit Response

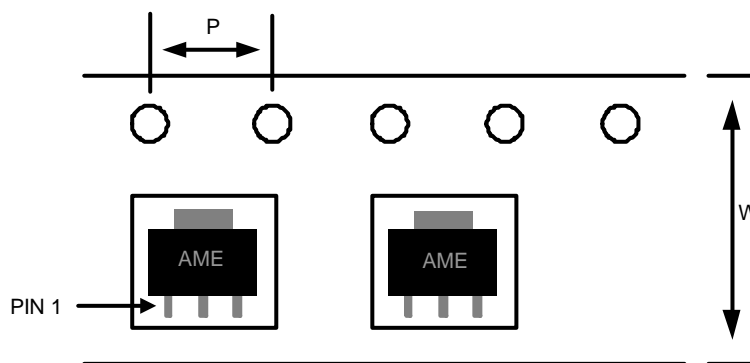
Short Circuit Response

■ Date Code Rule

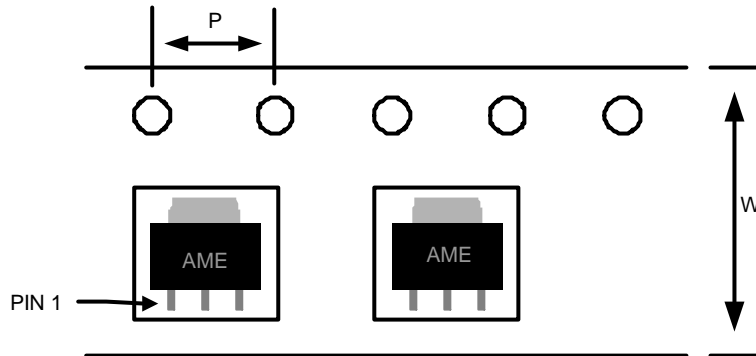
Marking			Date Code		Year
A	A	A	W	W	xxx0
A	A	A	W	<u>W</u>	xxx1
A	A	A	<u>W</u>	W	xxx2
A	A	A	<u>W</u>	<u>W</u>	xxx3
A	A	<u>A</u>	W	W	xxx4
A	A	<u>A</u>	W	<u>W</u>	xxx5
A	A	<u>A</u>	<u>W</u>	W	xxx6
A	A	<u>A</u>	<u>W</u>	<u>W</u>	xxx7
A	<u>A</u>	A	W	W	xxx8
A	<u>A</u>	A	W	<u>W</u>	xxx9

■ Tape & Reel Dimension
SOT-89

Carrier Tape, Number of Components Per Reel and Reel Size

Package	Carrier Width (W)	Pitch (P)	Part Per Full Reel	Reel Size
SOT-89	12.0±0.1 mm	4.0±0.1 mm	1000pcs	180±1 mm

■ Tape and Reel Dimension (Contd.)
SOT-223

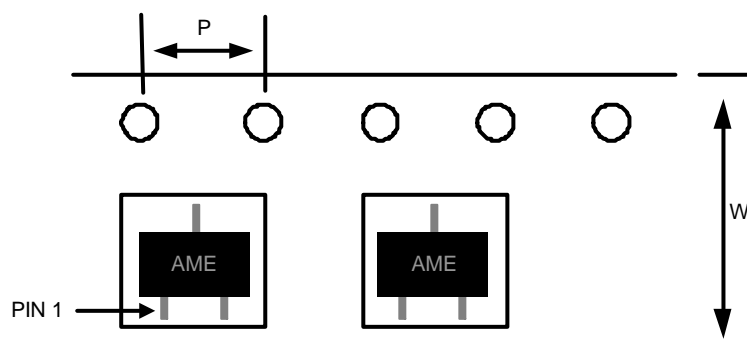
Carrier Tape, Number of Components Per Reel and Reel Size

Package	Carrier Width (W)	Pitch (P)	Part Per Full Reel	Reel Size
SOT-223	12.0±0.1 mm	4.0±0.1 mm	2500pcs	330±1 mm

SOT-23

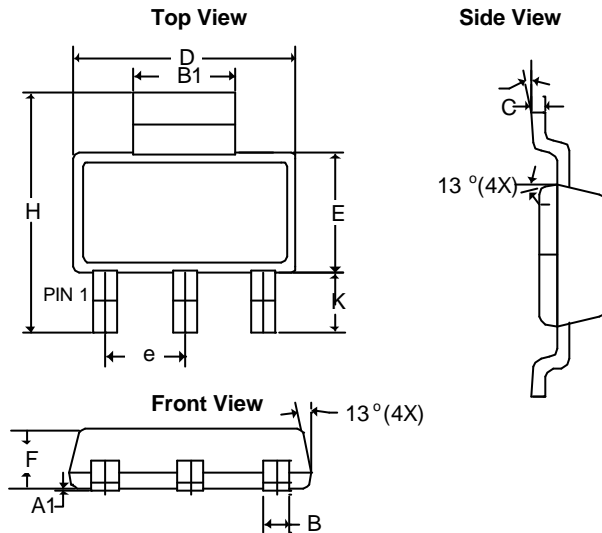
Carrier Tape, Number of Components Per Reel and Reel Size

Package	Carrier Width (W)	Pitch (P)	Part Per Full Reel	Reel Size
SOT-23	8.0±0.1 mm	4.0±0.1 mm	3000pcs	180±1 mm

■ Package Dimension
SOT-223

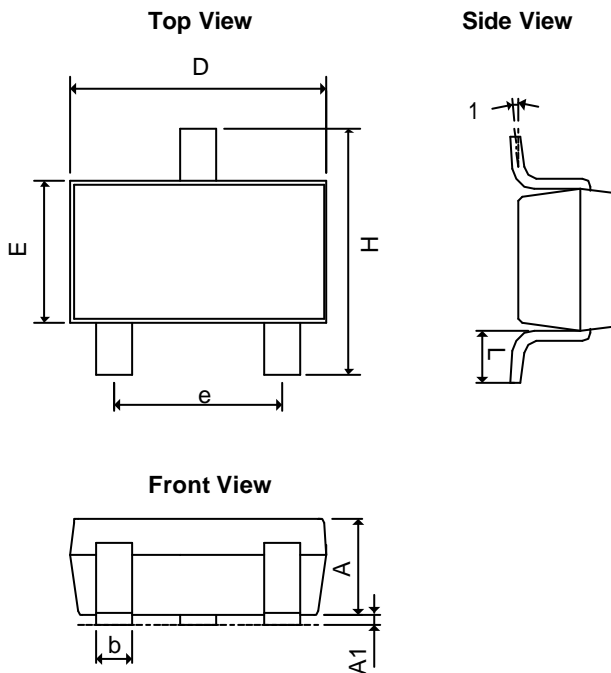
SYMBOLS	MILLIMETERS		INCHES	
	MIN	MAX	MIN	MAX
A ₁	0.01	0.10	0.0004	0.0039
B	0.60	0.84	0.0236	0.0330
B ₁	2.90	3.15	0.1140	0.1240
C	0.23	0.38	0.0091	0.0150
D	6.20	6.71	0.2441	0.2640
E	3.30	3.71	0.1299	0.1460
e	2.30 BSC		0.0906 BSC	
F	1.40	1.80	0.0551	0.0709
H	6.70	7.30	0.2638	0.2874
K	1.665	1.669	0.0656	0.0657
q	0°	10°	0°	10°

SOT-23

SYMBOLS	MILLIMETERS		INCHES	
	MIN	MAX	MIN	MAX
A	1.00	1.40	0.0394	0.0551
A ₁	0.00	0.15	0.0000	0.0059
b	0.35	0.50	0.0138	0.0197
D	2.70	3.10	0.1063	0.1220
E	1.40	1.80	0.0551	0.0709
e	1.90 BSC		0.0748 BSC	
H	2.40	3.00	0.09449	0.11811
L	0.35BSC		0.0138BSC	
q1	0°	10°	0°	10°

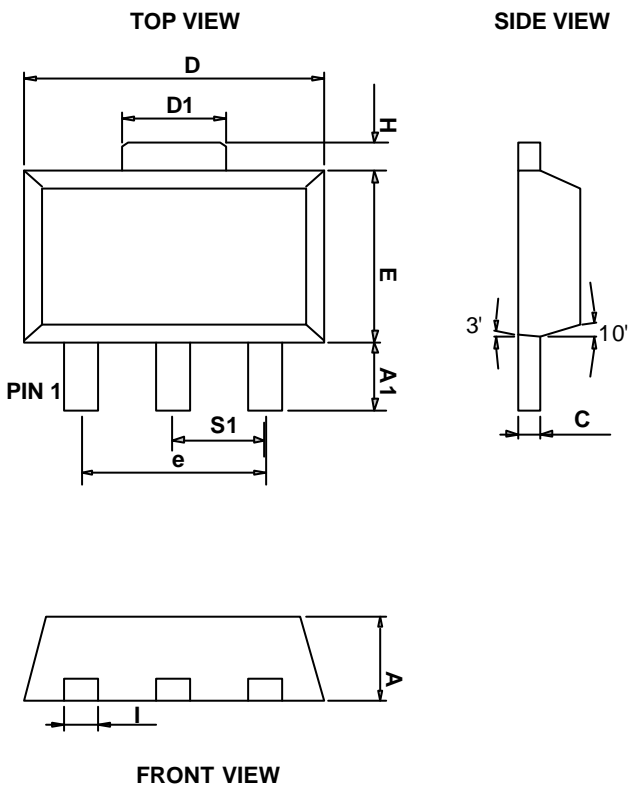
■ Package Dimension (Contd.)
SOT-89

SYMBOLS	MILLIMETERS		INCHES	
	MIN	MAX	MIN	MAX
A	1.39	1.60	0.0547	0.0630
A₁	0.8 REF		0.0315 REF	
C	0.35	0.44	0.0138	0.0173
D	4.39	4.60	0.1728	0.1811
D₁	1.35	1.85	0.0531	0.0728
E	2.28	2.60	0.0898	0.1024
I	0.32	0.56	0.0126	0.0220
e	3.00 REF		0.1181 REF	
H	0.70 REF		0.0276 REF	
S₁	1.50 REF		0.0591 REF	



www.ame.com.tw
E-Mail: sales@ame.com.tw

Life Support Policy:

These products of AME, Inc. are not authorized for use as critical components in life-support devices or systems, without the express written approval of the president of AME, Inc.

AME, Inc. reserves the right to make changes in the circuitry and specifications of its devices and advises its customers to obtain the latest version of relevant information.

© AME, Inc. , June 2013

Document: 2006/2095-DS8805/8813-R.13

Corporate Headquarter

AME, Inc.

8F, 12, WenHu St., Nei Hu

Taipei, Taiwan. 114

Tel: 886 2 2627-8687

Fax: 886 2 2659-2989

X-ON Electronics

Largest Supplier of Electrical and Electronic Components

Click to view similar products for [LDO Voltage Regulators](#) category:

Click to view products by [ON Semiconductor](#) manufacturer:

Other Similar products are found below :

[M38D29FFHP#U1](#) [702103A](#) [717726C](#) [742457H](#) [MP20051DN-LF-Z](#) [R5F111PGGFB#30](#) [AP7363-SP-13](#) [NCP103AMX285TCG](#)
[NCV8664CST33T3G](#) [NCV8752AMX28TCG](#) [L9454](#) [AP7362-HA-7](#) [LX13043CLD](#) [TCR3DF185,LM\(CT](#) [TCR3DF24,LM\(CT](#)
[TCR3DF285,LM\(CT](#) [TCR3DF31,LM\(CT](#) [TCR3DF45,LM\(CT](#) [TLF4949EJ](#) [L9708](#) [L970813TR](#) [030014BB](#) [059985X](#) [EAN61387601](#)
[EAN61573601](#) [NCP121AMX173TCG](#) [NCP4687DH15T1G](#) [NCV8703MX30TCG](#) [701326R](#) [702087BB](#) [755078E](#) [TCR2EN28,LF\(S](#)
[LM1117DT-1.8/NO](#) [LT1086CM#TRPBF](#) [AZ1085S2-1.5TRE1](#) [MAX15101EWL+T](#) [NCV8170AXV250T2G](#) [SCD337BTG](#)
[TCR3DF27,LM\(CT](#) [TCR3DF19,LM\(CT](#) [TCR3DF125,LM\(CT](#) [TCR2EN18,LF\(S](#) [MAX15103EWL+T](#) [TS2937CZ-5.0 C0](#) [MAX8878EUK30-](#)
[T](#) [MAX663CPA](#) [NCV4269CPD50R2G](#) [NCV8716MT30TBG](#) [AZ1117IH-1.2TRG1](#) [MP2013GQ-P](#)