



**Collimators for Proeon Series
Technical Datasheet
Version: 2.4**

Features

- High Efficiency
- RoHS compliant
- Works with ProLight Proeon Series

Typical Applications

- Lamp
- Reading lights
- Architectural lighting
- Street lights
- Decoration lights
- Down lights

Collimators List

Collimator Size	Collimator P/N	Matched Holder P/N	White / Warm White LED			
			View angle ($2\theta_{0.3}$)	Beam angle ($2\theta_{0.5}$)	On axis efficiency (cd/lm)	X*
20mm	PG1C-NX17	PG1C-SX17	20°	15°	10.20	35.6
	PG1C-NX36	PG1N-SO02	35°	25°	3.65	12.7
	PG1N-NX43	PG1N-SO02	45°	35°	1.55	5.3
	PG1C-NX43	PG1C-SX43	55°	45°	2.15	7.4
	PG1N-NX45	PG1N-SO02	60°	45°	0.85	3.0
	PM2A-NXVA	PM2A-SXV1	25° x 45°	15° x 35°	4.15	14.5
		PM2B-NX25-AW	25	19	6.00	20.7
		PM2B-NX35-AW	35	25	3.40	11.9
		PM2B-NX45-AW	45	35	2.95	10.3
		PM2B-NX55-AW	55	40	1.85	6.5
35mm	PM6A-FN20		25°	18°	4.95	17.2
	PM6A-FN25		35°	25°	2.90	10.1
76mm		PG1C-6A20-AW	23°	17°	8.55	29.9
		PG1C-6A30-AW	30°	23°	5.65	19.7
95mm		PG1C-9B30-AW	30°	23°	4.55	15.8
		PG1C-9B60-AW	75°	60°	0.90	3.1

Notes:

1. The typical angle varies with LED due to different color chip and chip position tolerance.
2. The view angle ($2\theta_{0.3}$ is similar to the image by eye view) is the full angle measured where the luminous intensity is 30% of the peak value.
3. The beam angle ($2\theta_{0.5}$) is the full angle measured where the luminous intensity is 50% of the peak value.

* X is the value that measurement of the on-axis lux of LED with lens divided by lux of LED

General Characteristics:

Lens Material	Optical Grade PMMA
Holder Material	PC or ABS
Operating Temperature Range	-40 °C to +70 °C
Storage Temperature Range	-40 °C to +70 °C

Usage and Maintenance:

1. Clean collimators with mild soap and water and a soft cloth.
2. Do not use any commercial cleaning solvents on collimators, like alcohol.
3. Please handle or install collimators with wearing gloves, skin oils may damage collimators or optical characteristic.

Mechanical Dimensions and Illuminance Chart

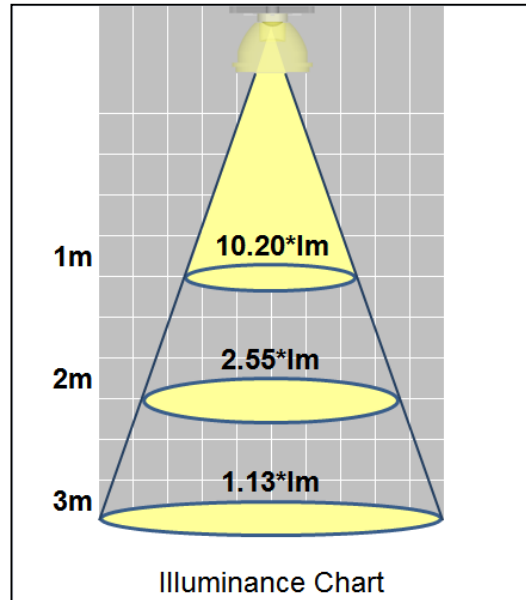

Collimator P/N : PG1C-NX17

View angle ($2\theta_{0.3}$) : 20°

Beam angle ($2\theta_{0.5}$) : 15°

Matched Holder P/N : PG1C-SX17

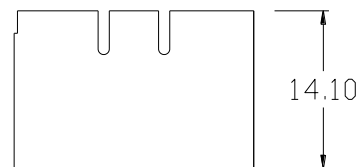
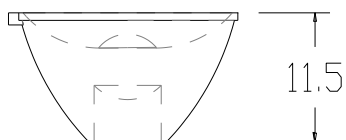
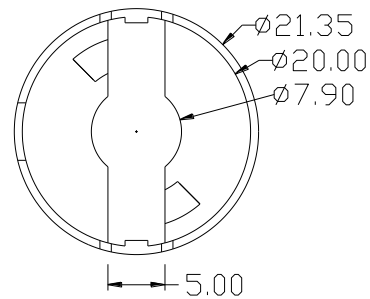
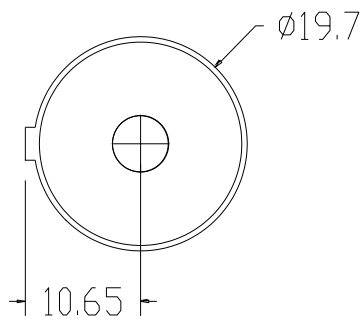

Notes:

1. Tolerance is ± 0.20 mm.
2. Do not subject to temperatures greater than 70°C as plastic deformation may occur.
Protect collimator against exposure to solvents and adhesives that are not compatible with it.
Use care in handling the optic to avoid scratches or other damage that will effect the optical performance.
3. All dimensions in millimeters.
4. Drawing not to scale.

*The appearance and specifications of the product may be modified for improvement without notice.

Mechanical Dimensions and Illuminance Chart

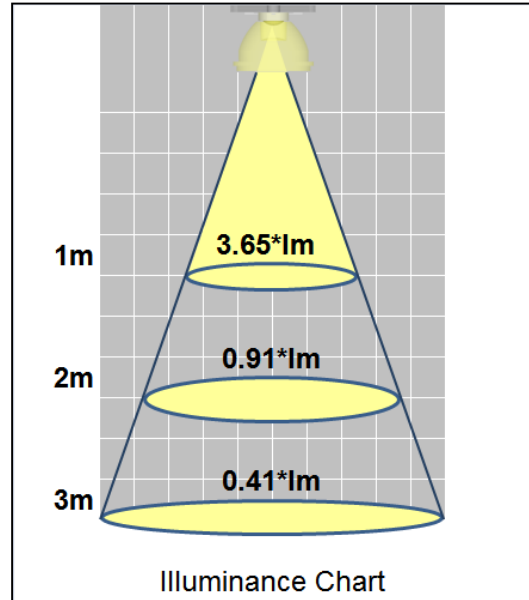

Collimator P/N : PG1C-NX36

View angle ($2\theta_{0.3}$) : 35°

Beam angle ($2\theta_{0.5}$) : 25°

Matched Holder P/N : PG1N-SO02

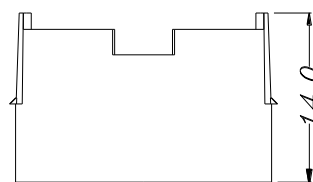
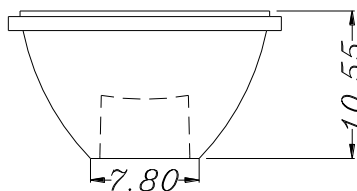
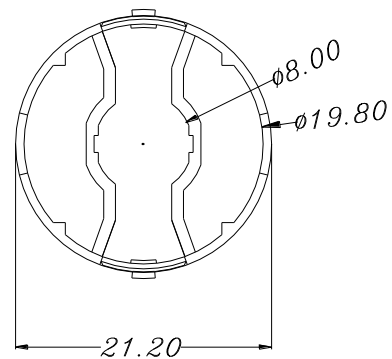
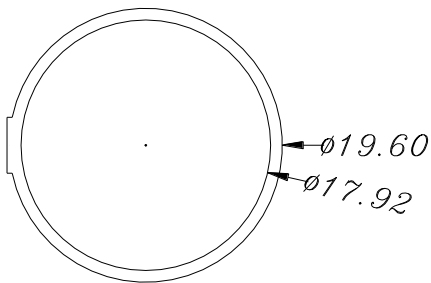

Notes:

1. Tolerance is ± 0.20 mm.
2. Do not subject to temperatures greater than 70°C as plastic deformation may occur.
Protect collimator against exposure to solvents and adhesives that are not compatible with it.
Use care in handling the optic to avoid scratches or other damage that will effect the optical performance.
3. All dimensions in millimeters.
4. Drawing not to scale.

*The appearance and specifications of the product may be modified for improvement without notice.

ProLight

Mechanical Dimensions and Illuminance Chart



Collimator P/N : PG1N-NX43
 View angle ($2\theta_{0.3}$) : 45°
 Beam angle ($2\theta_{0.5}$) : 35°

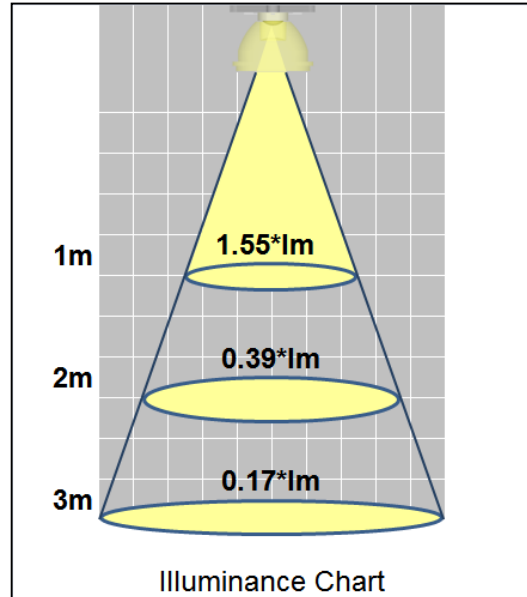

Matched Holder P/N : PG1N-SO02

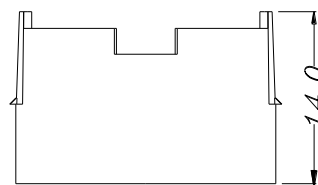
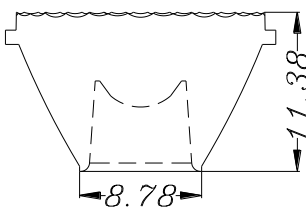
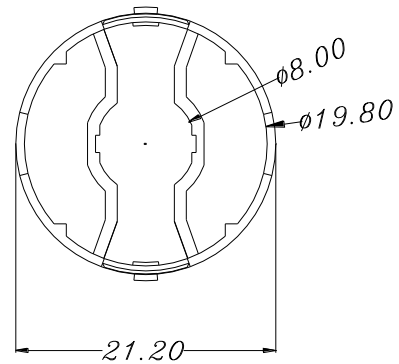
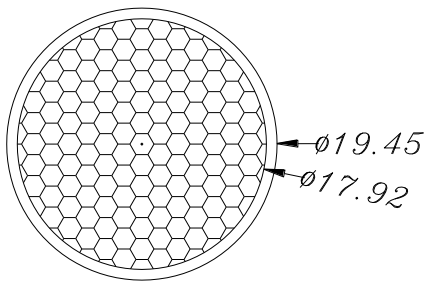

Notes:

1. Tolerance is ± 0.20 mm.
2. Do not subject to temperatures greater than 70°C as plastic deformation may occur.
 Protect collimator against exposure to solvents and adhesives that are not compatible with it.
 Use care in handling the optic to avoid scratches or other damage that will effect the optical performance.
3. All dimensions in millimeters.
4. Drawing not to scale.

*The appearance and specifications of the product may be modified for improvement without notice.

Mechanical Dimensions and Illuminance Chart

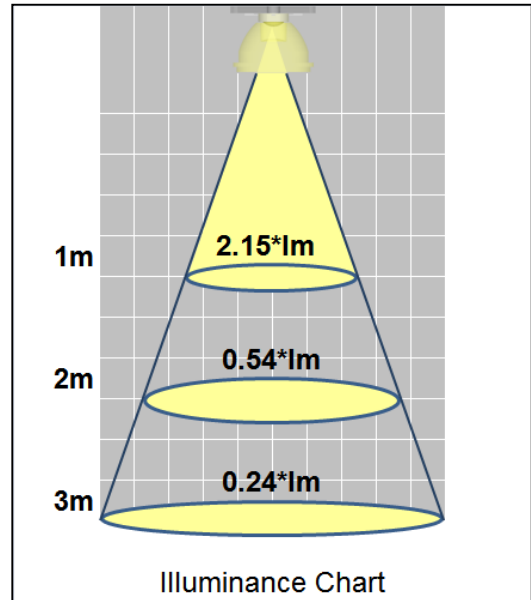

Collimator P/N : PG1C-NX43

View angle ($2\theta_{0.3}$) : 55°

Beam angle ($2\theta_{0.5}$) : 45°

Matched Holder P/N : PG1C-SX43

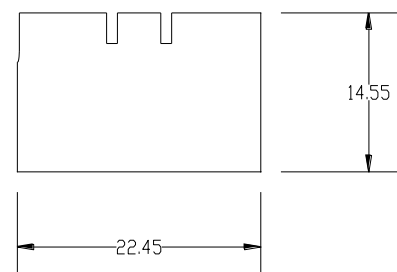
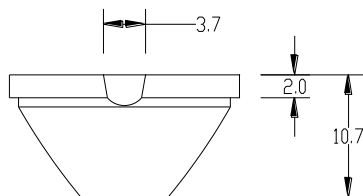
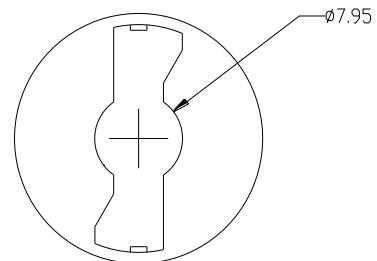
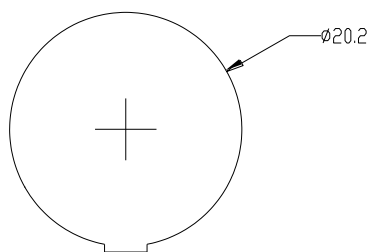

Notes:

1. Tolerance is ± 0.20 mm.
2. Do not subject to temperatures greater than 70°C as plastic deformation may occur.
Protect collimator against exposure to solvents and adhesives that are not compatible with it.
Use care in handling the optic to avoid scratches or other damage that will effect the optical performance.
3. All dimensions in millimeters.
4. Drawing not to scale.

*The appearance and specifications of the product may be modified for improvement without notice.

ProLight

Mechanical Dimensions and Illuminance Chart



Collimator P/N : PG1N-NX45
 View angle ($2\theta_{0.3}$) : 60°
 Beam angle ($2\theta_{0.5}$) : 45°

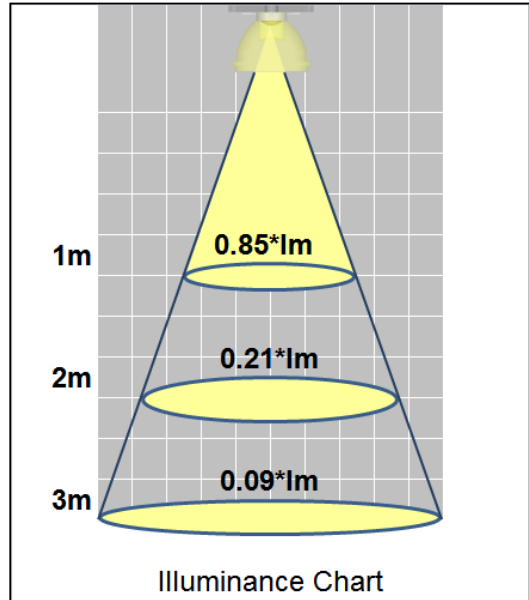

Matched Holder P/N : PG1N-SO02

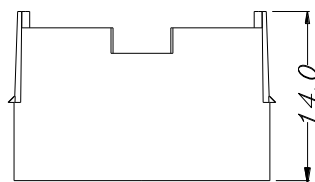
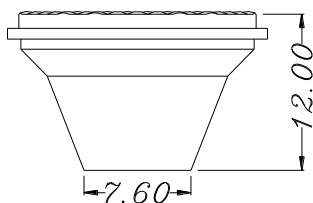
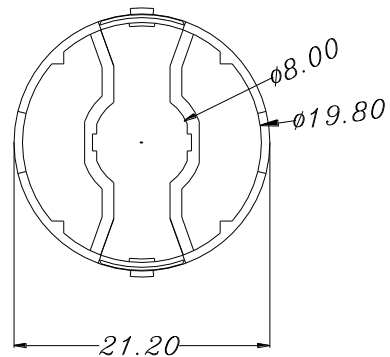
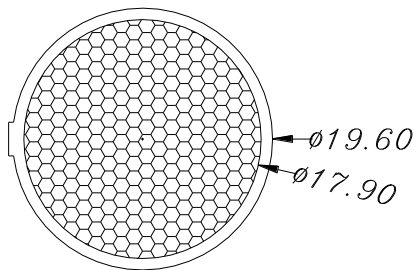

Notes:

1. Tolerance is ± 0.20 mm.
2. Do not subject to temperatures greater than 70°C as plastic deformation may occur.
 Protect collimator against exposure to solvents and adhesives that are not compatible with it.
 Use care in handling the optic to avoid scratches or other damage that will effect the optical performance.
3. All dimensions in millimeters.
4. Drawing not to scale.

*The appearance and specifications of the product may be modified for improvement without notice.

Mechanical Dimensions and Illuminance Chart



Collimator P/N : PM2A-NXVA
 View angle ($2\theta_{0.3}$) : $25^\circ \times 45^\circ$
 Beam angle ($2\theta_{0.5}$) : $15^\circ \times 35^\circ$

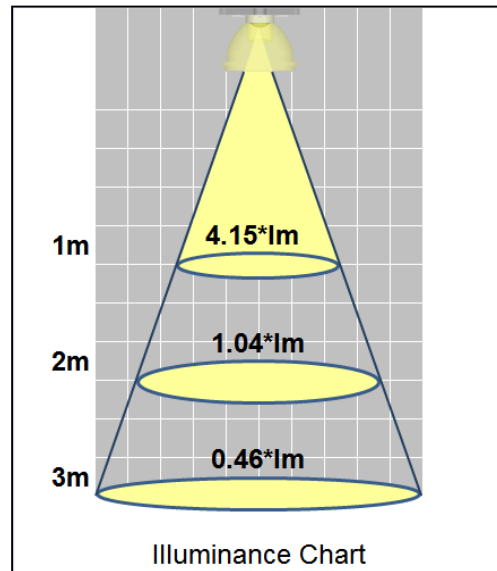

Matched Holder P/N : PM2A-SXV1

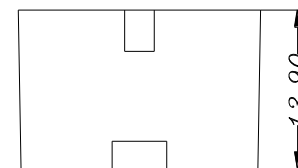
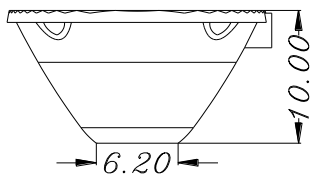
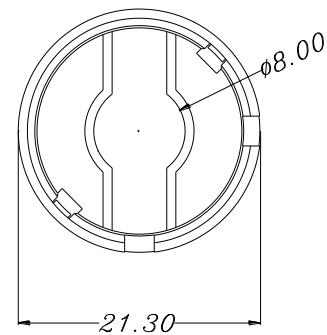
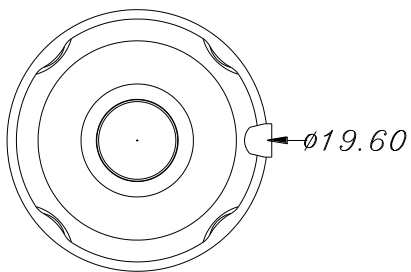

Notes:

1. Tolerance is ± 0.20 mm.
2. Do not subject to temperatures greater than 70°C as plastic deformation may occur.
 Protect collimator against exposure to solvents and adhesives that are not compatible with it.
 Use care in handling the optic to avoid scratches or other damage that will effect the optical performance.
3. All dimensions in millimeters.
4. Drawing not to scale.

*The appearance and specifications of the product may be modified for improvement without notice.

Mechanical Dimensions and Illuminance Chart

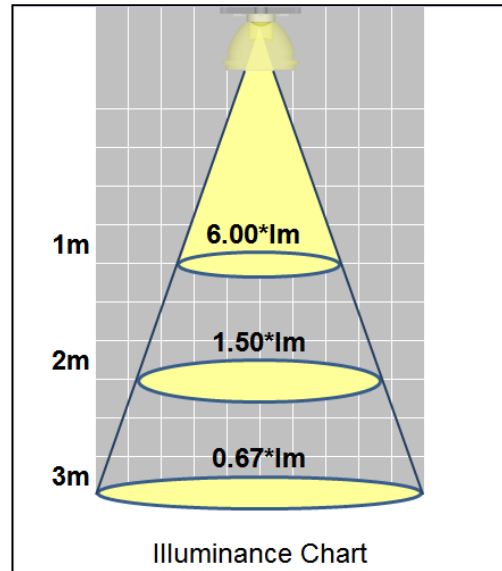

Collimator P/N : PM2B-NX25-AW

View angle ($2\theta_{0.3}$) : 25°

Beam angle ($2\theta_{0.5}$) : 19°

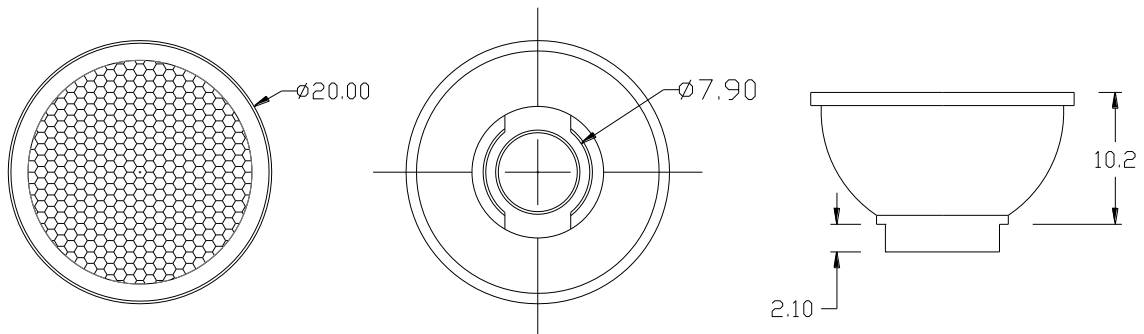

Notes:

1. Tolerance is ± 0.20 mm.
2. Do not subject to temperatures greater than 70°C as plastic deformation may occur.
Protect collimator against exposure to solvents and adhesives that are not compatible with it.
Use care in handling the optic to avoid scratches or other damage that will effect the optical performance.
3. All dimensions in millimeters.
4. Drawing not to scale.

*The appearance and specifications of the product may be modified for improvement without notice.

ProLight

Mechanical Dimensions and Illuminance Chart

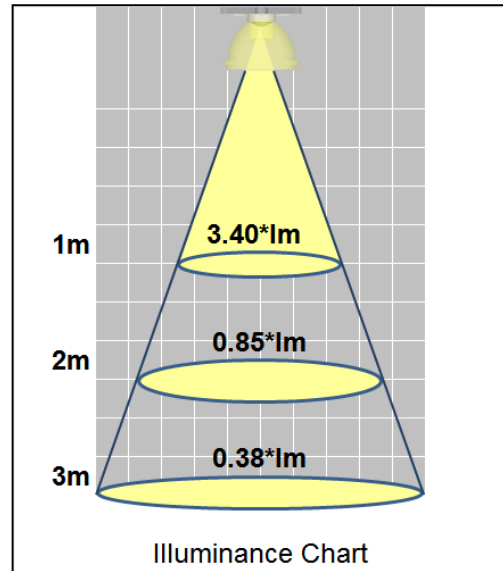

Collimator P/N : PM2B-NX35-AW

View angle ($2\theta_{0.3}$) : 35°

Beam angle ($2\theta_{0.5}$) : 25°

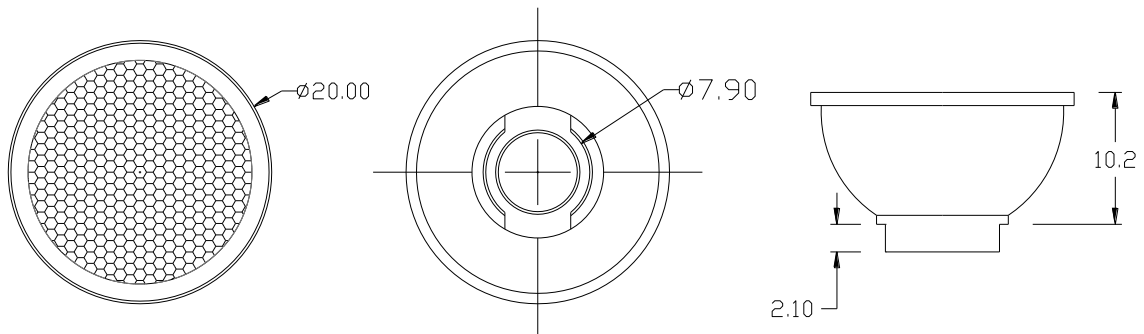

Notes:

1. Tolerance is ± 0.20 mm.
2. Do not subject to temperatures greater than 70°C as plastic deformation may occur.
Protect collimator against exposure to solvents and adhesives that are not compatible with it.
Use care in handling the optic to avoid scratches or other damage that will effect the optical performance.
3. All dimensions in millimeters.
4. Drawing not to scale.

*The appearance and specifications of the product may be modified for improvement without notice.

ProLight

Mechanical Dimensions and Illuminance Chart

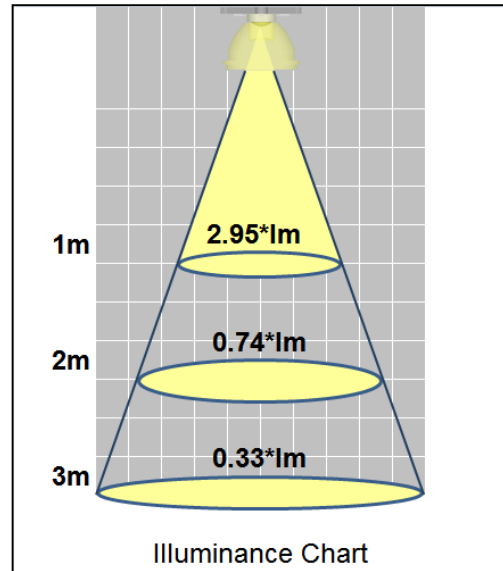

Collimator P/N : PM2B-NX45-AW

View angle ($2\theta_{0.3}$) : 45°

Beam angle ($2\theta_{0.5}$) : 35°

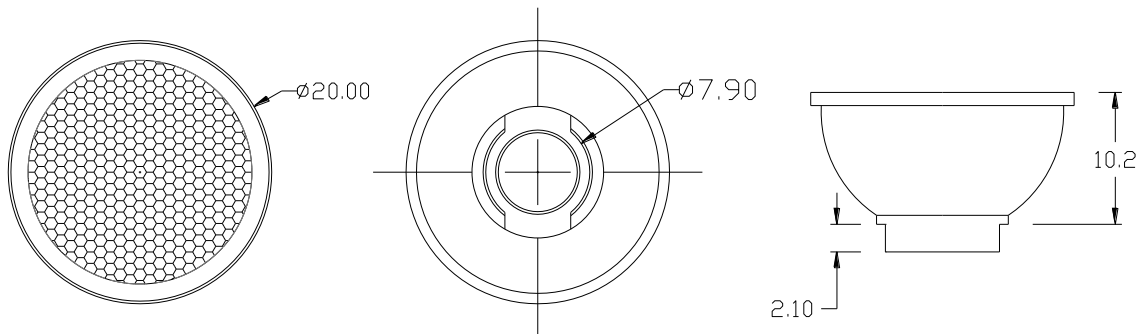

Notes:

1. Tolerance is ± 0.20 mm.
2. Do not subject to temperatures greater than 70°C as plastic deformation may occur.
Protect collimator against exposure to solvents and adhesives that are not compatible with it.
Use care in handling the optic to avoid scratches or other damage that will effect the optical performance.
3. All dimensions in millimeters.
4. Drawing not to scale.

*The appearance and specifications of the product may be modified for improvement without notice.

ProLight

Mechanical Dimensions and Illuminance Chart

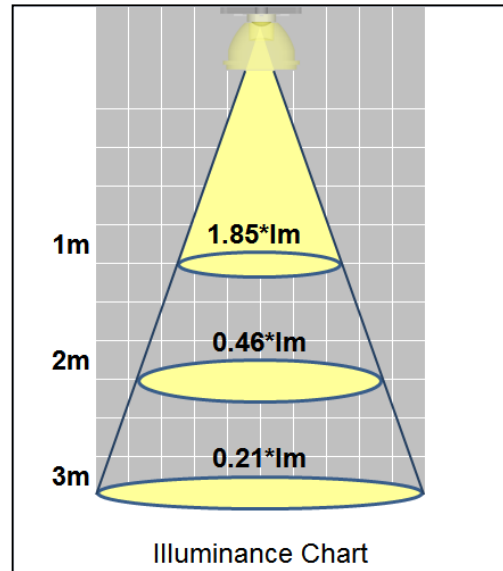

Collimator P/N : PM2B-NX55-AW

View angle ($2\theta_{0.3}$) : 55°

Beam angle ($2\theta_{0.5}$) : 40°

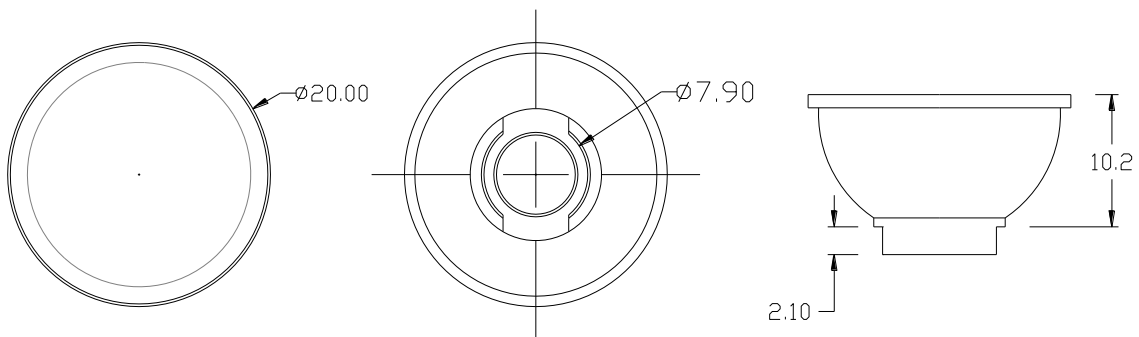

Notes:

1. Tolerance is ± 0.20 mm.
2. Do not subject to temperatures greater than 70°C as plastic deformation may occur.
Protect collimator against exposure to solvents and adhesives that are not compatible with it.
Use care in handling the optic to avoid scratches or other damage that will effect the optical performance.
3. All dimensions in millimeters.
4. Drawing not to scale.

*The appearance and specifications of the product may be modified for improvement without notice.

ProLight

Mechanical Dimensions and Illuminance Chart

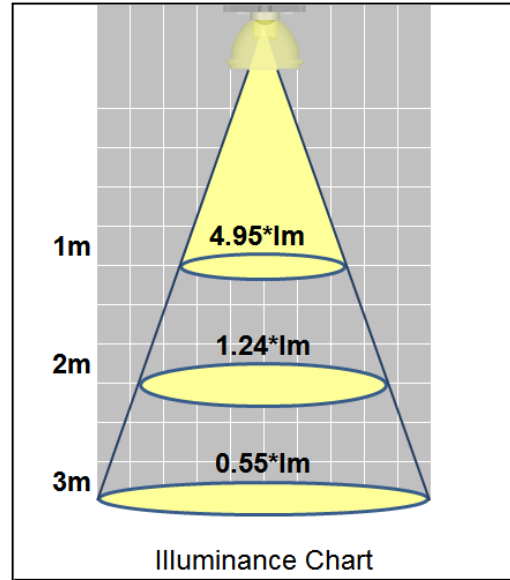

Collimator P/N : PM6A-FN20

View angle ($2\theta_{0.3}$) : 25°

Beam angle ($2\theta_{0.5}$) : 18°

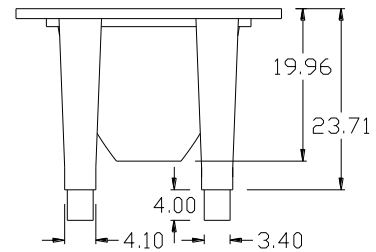
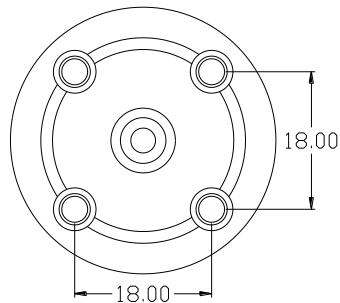
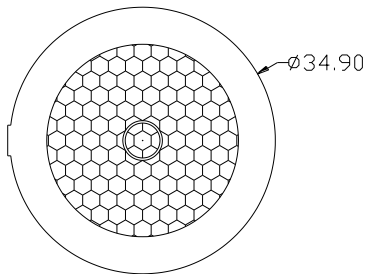

Notes:

1. Tolerance is ± 0.20 mm.
2. Do not subject to temperatures greater than 70°C as plastic deformation may occur.
Protect collimator against exposure to solvents and adhesives that are not compatible with it.
Use care in handling the optic to avoid scratches or other damage that will effect the optical performance.
3. All dimensions in millimeters.
4. Drawing not to scale.

*The appearance and specifications of the product may be modified for improvement without notice.

ProLight

Mechanical Dimensions and Illuminance Chart

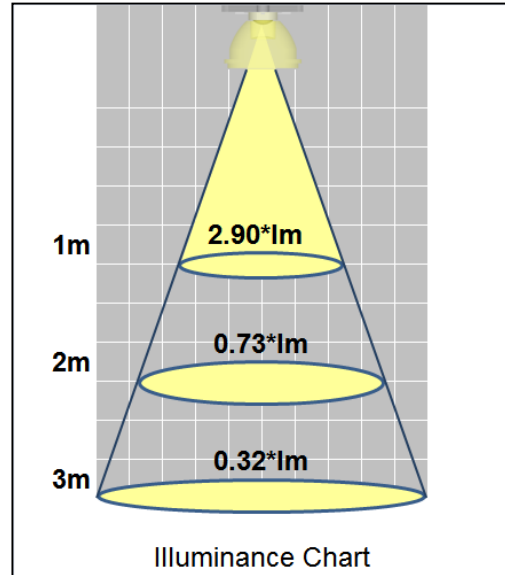

Collimator P/N : PM6A-FN25

View angle ($2\theta_{0.3}$) : 35°

Beam angle ($2\theta_{0.5}$) : 25°

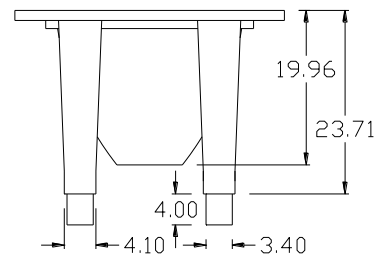
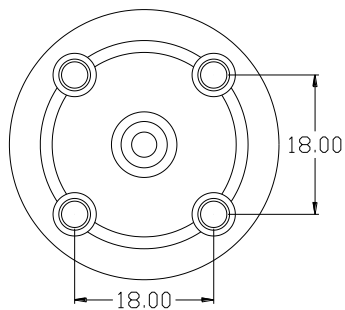
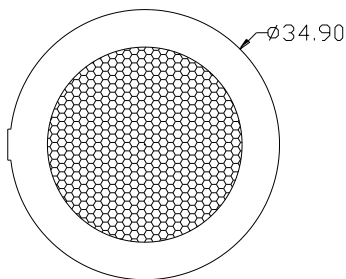

Notes:

1. Tolerance is ± 0.20 mm.
2. Do not subject to temperatures greater than 70°C as plastic deformation may occur.
Protect collimator against exposure to solvents and adhesives that are not compatible with it.
Use care in handling the optic to avoid scratches or other damage that will effect the optical performance.
3. All dimensions in millimeters.
4. Drawing not to scale.

*The appearance and specifications of the product may be modified for improvement without notice.

ProLight

Mechanical Dimensions and Illuminance Chart

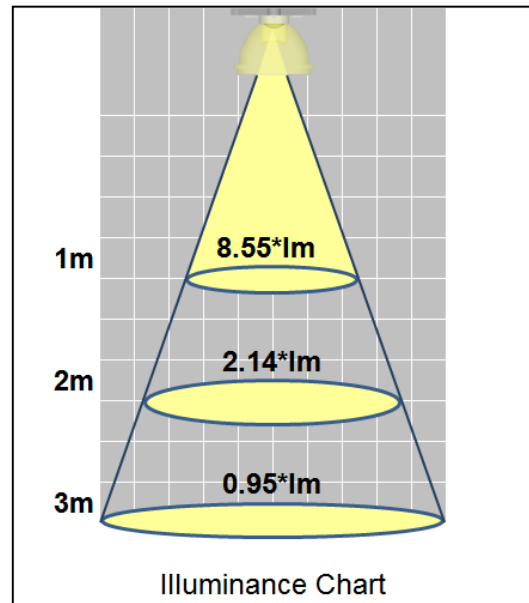

Collimator P/N : PG1C-6A20-AW

View angle ($2\theta_{0.3}$) : 23°

Beam angle ($2\theta_{0.5}$) : 17°

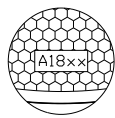
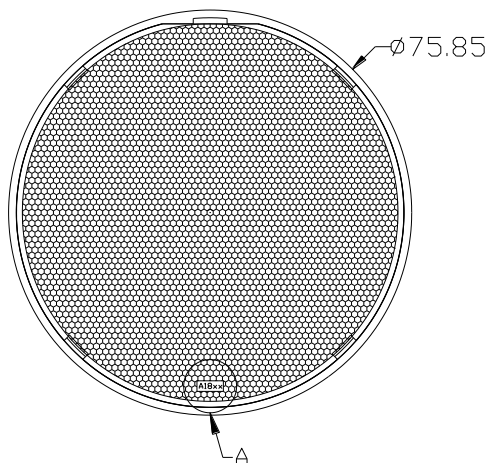

A: scale 2:1

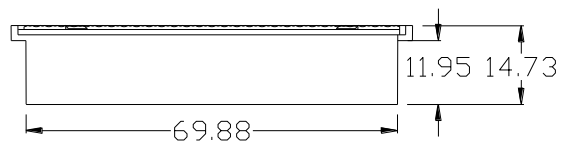
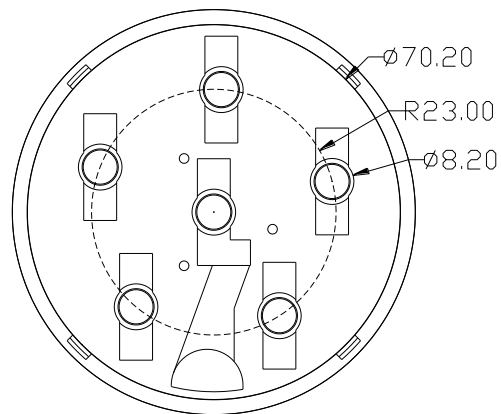

Notes:

1. Tolerance is ± 0.20 mm.
2. Do not subject to temperatures greater than 70°C as plastic deformation may occur.
Protect collimator against exposure to solvents and adhesives that are not compatible with it.
Use care in handling the optic to avoid scratches or other damage that will effect the optical performance.
3. All dimensions in millimeters.
4. Drawing not to scale.

*The appearance and specifications of the product may be modified for improvement without notice.

ProLight

Mechanical Dimensions and Illuminance Chart

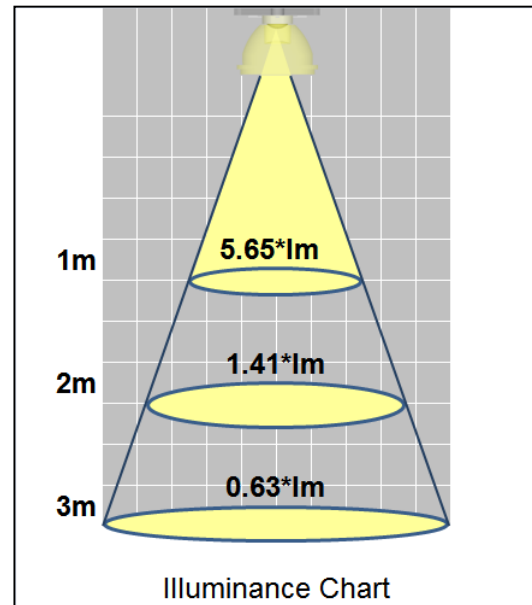

Collimator P/N : PG1C-6A30-AW

View angle ($2\theta_{0.3}$) : 30°

Beam angle ($2\theta_{0.5}$) : 23°

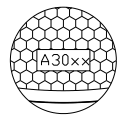
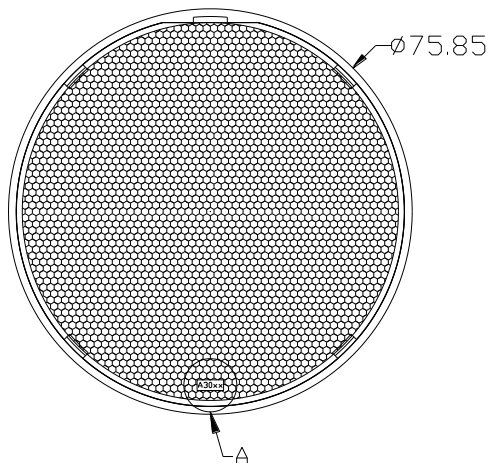

A: scale 2:1

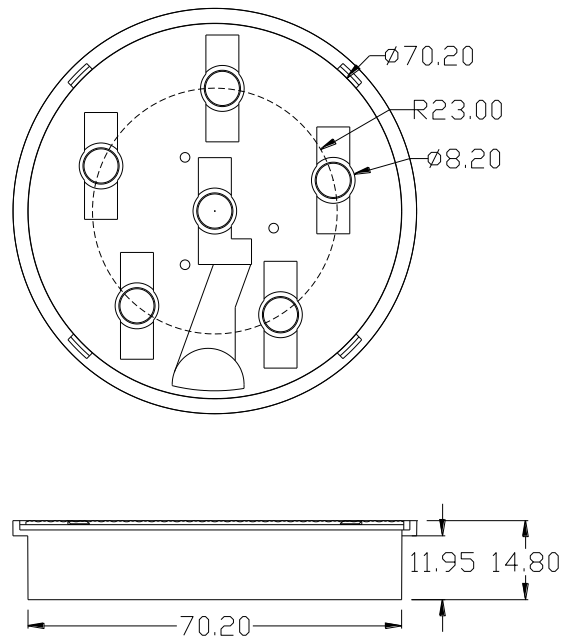

Notes:

1. Tolerance is ± 0.20 mm.
2. Do not subject to temperatures greater than 70°C as plastic deformation may occur.
Protect collimator against exposure to solvents and adhesives that are not compatible with it.
Use care in handling the optic to avoid scratches or other damage that will effect the optical performance.
3. All dimensions in millimeters.
4. Drawing not to scale.

*The appearance and specifications of the product may be modified for improvement without notice.

ProLight

Mechanical Dimensions and Illuminance Chart

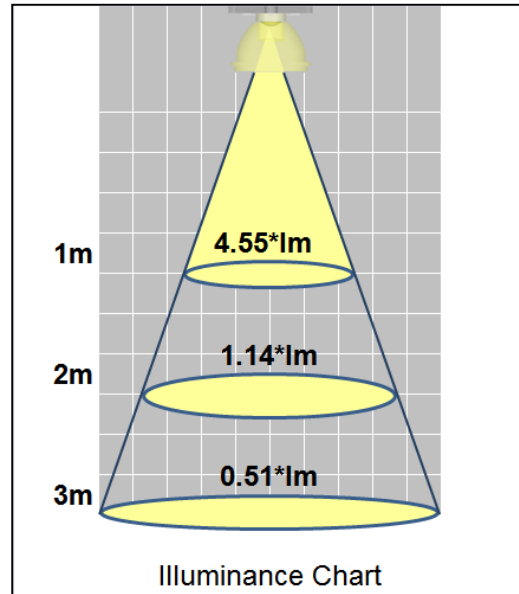

Collimator P/N : PG1C-9B30-AW

View angle ($2\theta_{0.3}$) : 30°

Beam angle ($2\theta_{0.5}$) : 23°

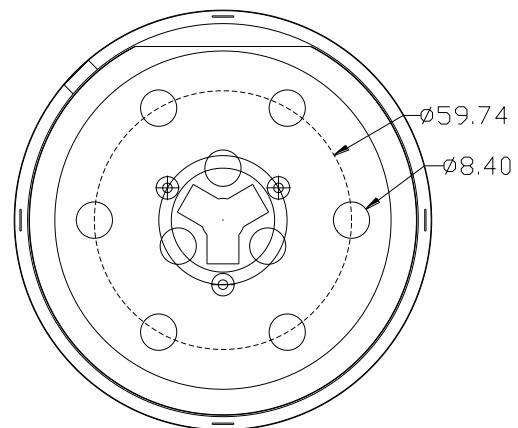
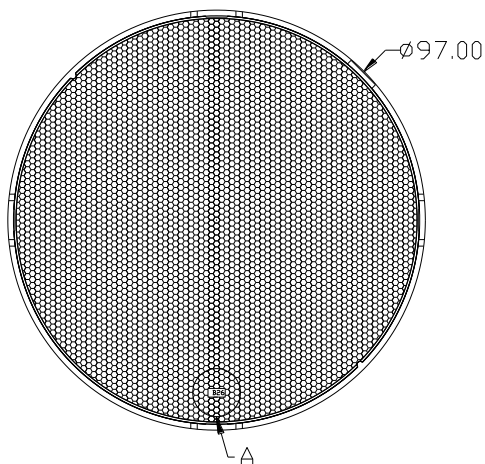

A: scale 2:1

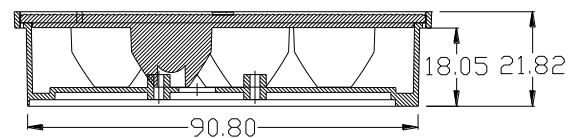

Notes:

1. Tolerance is ± 0.20 mm.
2. Do not subject to temperatures greater than 70°C as plastic deformation may occur.
Protect collimator against exposure to solvents and adhesives that are not compatible with it.
Use care in handling the optic to avoid scratches or other damage that will effect the optical performance.
3. All dimensions in millimeters.
4. Drawing not to scale.

*The appearance and specifications of the product may be modified for improvement without notice.

ProLight

Mechanical Dimensions and Illuminance Chart

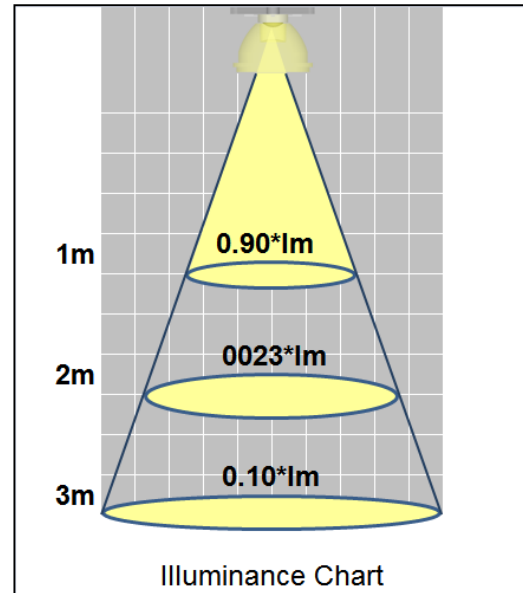

Collimator P/N : PG1C-9B60-AW

View angle ($2\theta_{0.3}$) : 75°

Beam angle ($2\theta_{0.5}$) : 60°

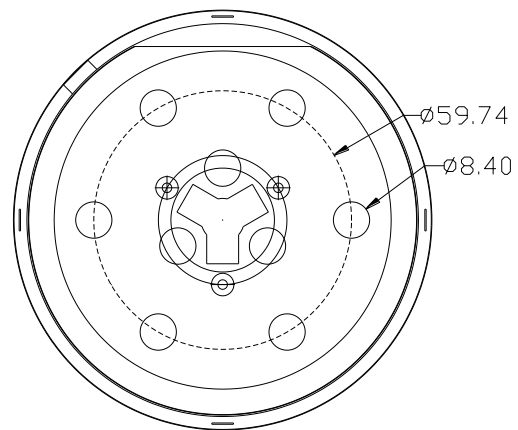
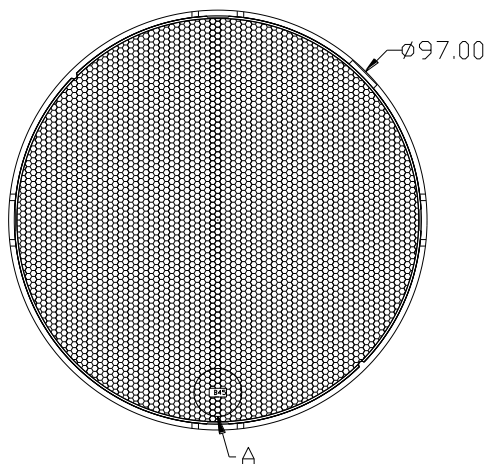

A: scale 2:1

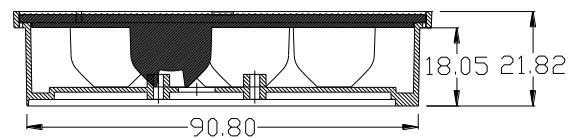

Notes:

1. Tolerance is ± 0.20 mm.
2. Do not subject to temperatures greater than 70°C as plastic deformation may occur.
Protect collimator against exposure to solvents and adhesives that are not compatible with it.
Use care in handling the optic to avoid scratches or other damage that will effect the optical performance.
3. All dimensions in millimeters.
4. Drawing not to scale.

*The appearance and specifications of the product may be modified for improvement without notice.

ProLight

X-ON Electronics

Largest Supplier of Electrical and Electronic Components

Click to view similar products for [LED Lighting Lenses](#) category:

Click to view products by [Prolight](#) manufacturer:

Other Similar products are found below :

[LL01ED-AK40L06](#) [LL01ZZ-EX25L06-M2](#) [180182-0000](#) [FNP-N2-N083-0R NRW](#) [LL01ED-ALI55R49](#) [0190535300](#) [0410111300](#)
[0510113303](#) [0530997](#) [2710121](#) [C11004_TINA2-RS](#) [C12231_LENA-FRESNEL-LENS](#) [LL01ED-AKY24R49](#) [LL01CR-AYG15R49](#)
[LL01CR-OT32L06-M2](#) [LL01ZZ-AAA24L49](#) [LL01CR-CEN38L02](#) [LL01ZZ-AAA55L49](#) [LL01CR-AYG24R49](#) [LL01A00CZMB2-M2](#)
[LL01ED-AKY38R49](#) [LL01CR-CNE2545L06-M2](#) [LL01ZZ-AAA38L49](#) [LL01ED-AKV36R49](#) [LL01ED-ALI24R49](#) [LL01CR-AYG38R49](#)
[FN15973_RONDA-REC-60-C](#) [F16859_LINDA-ZT25](#) [C14169_LENA-CLEAR-LENS](#) [C16125_OLGA-W](#) [C17410_SPORT-2X2-FT6](#)
[C17414_SPORT-2X2-S6](#) [C17409_SPORT-2X2-FT6W](#) [C17360_SPORT-2X2-FT60](#) [C17434_ILONA-WW](#) [F16636_LINDA-W60](#) [10003](#)
[10003/15](#) [10048](#) [10049](#) [10108](#) [CP10960_RGBX-SS](#) [CP12395_LXP3-W](#) [10415](#) [10510](#) [1-1000288-0](#) [F14487_FLORENCE-1R-MAXI-WG](#)
[12667](#) [C14165_STRADA-2X2-ME-WIDE2](#) [C14605_HB-2X2-RW](#)