



MIC3230/1/2

Constant Current Boost Controller for Driving High Power LEDs

General Description

The MIC3230/1/2 are constant current boost switching controllers specifically designed to power one or more strings of high power LEDs. The MIC3230/1/2 have an input voltage range from 6V to 45V and are ideal for a variety of solid state lighting applications.

The MIC3230/1/2 utilizes an external power device which offers a cost conscious solution for high power LED applications. The powerful drive circuitry can deliver up to 70W to the LED system. Power consumption has been minimized through the implementation of a 250mV feedback voltage reference providing an accuracy of $\pm 3\%$. The MIC323x family is dimmable via a pulse width modulated (PWM) input signal and also features an enable pin for low power shutdown.

Multiple MIC3230 ICs can be synchronized to a common operating frequency. The clocks of these synchronized devices can be used together in order to help reduce noise and errors in a system.

An external resistor sets the adjustable switching frequency of the MIC3230/1. The switching frequency can be between 100kHz and 1MHz. Setting the switching frequency provides the mechanism by which a design can be optimized for efficiency (performance) and size of the external components (cost). The MIC323x family of LED drivers also offer the following protection features: Over voltage protection (OVP), thermal shutdown and under-voltage lock-out (UVLO).

The MIC3231 offers a dither feature to assist in the reduction of EMI. This is particularly useful in sensitive EMI applications, and provides for a reduction or emissions by approximately 10dB.

The MIC3232 is a 400kHz fixed frequency device offered in a small 10-pin MSOP package. The MIC3230/1 are offered in both the EPAD 16-pin TSSOP package and the 12-pin 3mm x 3mm MLF[®] package.

Datasheets and support documentation can be found on Micrel's web site at: www.micrel.com.



Bringing the Power to Light™

Features

- 6V to 45V input supply range
- Capable of driving up to 70W
- Ultra low EMI via dithering on the MIC3231
- Programmable LED drive current
- Feedback voltage = 250mV $\pm 3\%$
- Programmable switching frequency (MIC3230/1) or 400kHz fixed frequency operation (MIC3232)
- PWM Dimming and separate enable shutdown
- Frequency synchronization with other MIC3230s
- Protection features:
 - Over Voltage Protection (OVP)
 - Over temperature protection
 - Under-voltage Lock-out (UVLO)

- Packages:

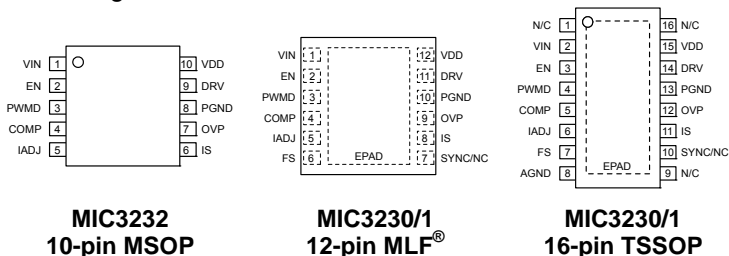

- -40°C to $+125^{\circ}\text{C}$ junction temperature range

Applications

- Street lighting
- Solid state lighting
- General illumination
- Architectural lighting
- Constant current power supplies

Bringing the Power to Light is a trademark of Micrel, Inc.
MicroLeadFrame and MLF are registered trademarks of Amkor Technology.

Micrel Inc. • 2180 Fortune Drive • San Jose, CA 95131 • USA • tel +1 (408) 944-0800 • fax +1 (408) 474-1000 • <http://www.micrel.com>

Typical Application

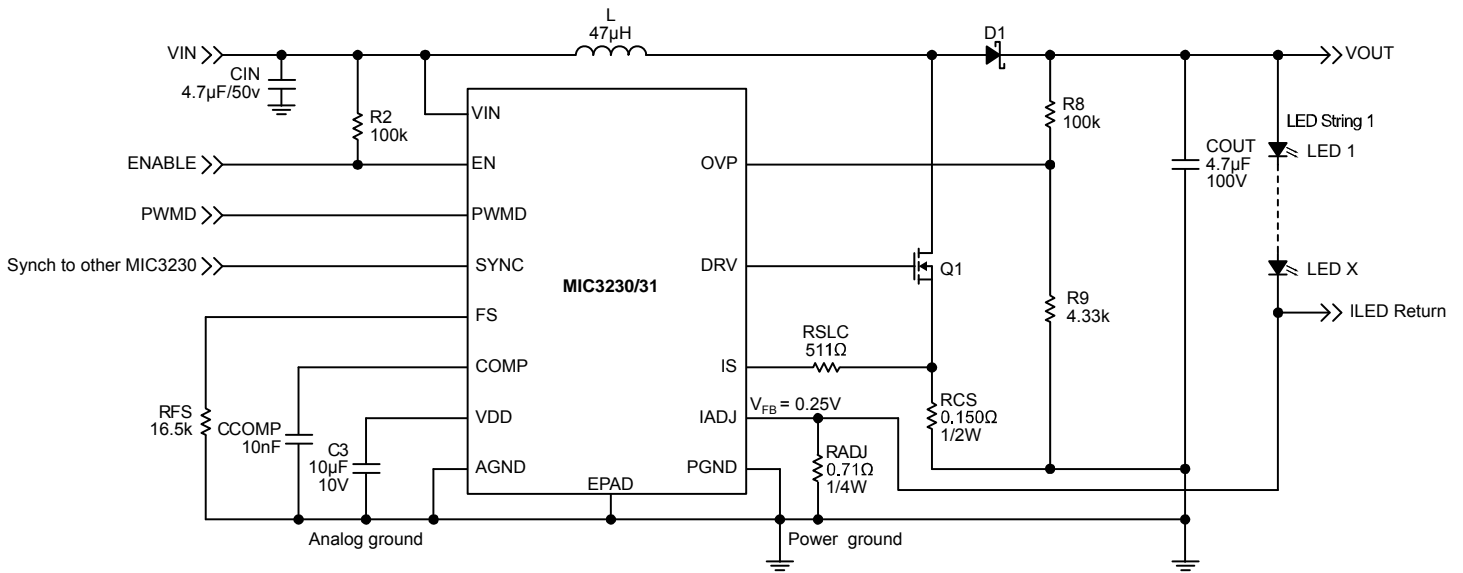

Figure 1. Typical Application of the MIC3230 LED Driver

Product Option Matrix

	MIC3230	MIC3231	MIC3232
Input Voltage	6V to 45V	6V to 45V	6V to 45V
Synchronization	Yes	No	No
Dither	No	Yes	No
Frequency Range	Adj from 100kHz to 1MHz	Adj from 100kHz to 1MHz	Fixed Freq. = 400kHz
Package	16-pin EPAD TSSOP 12-pin 3mm x 3mm MLF [®]	16-pin EPAD TSSOP 12-pin 3mm x 3mm MLF [®]	10-pin MSOP

Ordering Information

Part Number	Temperature Range	Package	Lead Finish
MIC3230YTSE	-40° to +125°C	16-pin EPAD TSSOP	Pb-Free
MIC3230YML	-40° to +125°C	12-pin 3mm x 3mm MLF [®]	Pb-Free
MIC3231YTSE	-40° to +125°C	16-pin EPAD TSSOP	Pb-Free
MIC3231YML	-40° to +125°C	12-pin 3mm x 3mm MLF [®]	Pb-Free
MIC3232YMM	-40° to +125°C	10-pin MSOP	Pb-Free

Pin Configuration

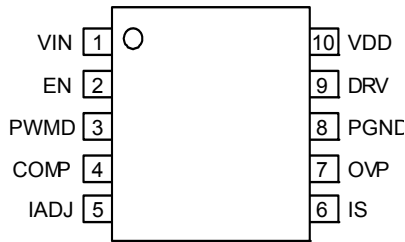

10-Pin MSOP (MM)
MIC3232

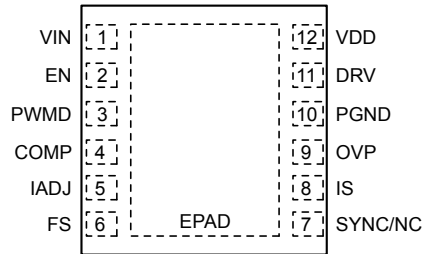

12-Pin 3mmx3mmMLF[®] (ML)
MIC3230, MIC3231
See Product Option Matrix for selection

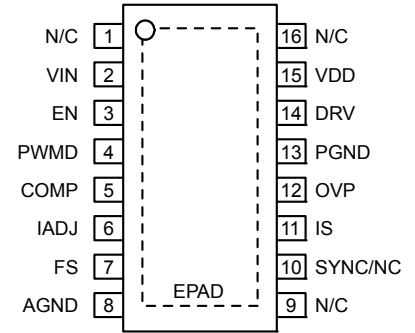

16-Pin TSSOP (TSE)
MIC3230, MIC3231
See Product Option Matrix for selection

Pin Description

Pin Number MLF [®]	Pin Number TSSOP	Pin Number MSOP	Pin Name	Pin Function
--	1	--	NC	No Connect.
1	2	1	VIN	Input Voltage (power) 6V to 45V.
2	3	2	EN	Enable Control (Input). Logic High ($\geq 1.5V$) enables the regulator. Logic Low ($\leq 0.4V$) shuts down the regulator. Connect a 100k Ω resistor from EN to VIN.
3	4	3	PWMD	PWM Dimming Input. Logic Low will disable the brightness control of the LED drivers.
4	5	4	COMP	Compensation (output): for external compensation.
5	6	5	IADJ	Feedback (input).
6	7	--	FS	Frequency Select (input). Connected to a Resistor to determine the operating frequency.
--	8	--	AGND	Analog Ground.
--	9	--	NC	No Connect.
7	10	--	SYNC	Sync (output). Connect to another MIC3230 to synchronize multiple converters.
8	11	6	IS	Current Sense (input). Connected to external current sense resistor which in turn is connected to the source of the external FET as well as an external slope compensation resistor.
9	12	7	OVP	OVP divider connection (output). Connect the top of the divider string to the output. If the load is disconnected, the output voltage will rise until OVP reaches 1.25V and then will regulate around this point.
10	13	8	PGND	Power Ground.
11	14	9	DRV	Drive Output: connect to the gate of external FET (output).
12	15	10	VDD	VDD Filter for internal power rail. Do not connect an external load to this pin. Connect 10 μ F to GND.
--	16	--	NC	No Connect.
--	--	--	EPAD	Connect to AGND.

Absolute Maximum Ratings⁽¹⁾

Supply Voltage (V_{IN})	+48V
Enable Pin Voltage	-0.3V to +6V
IADJ Voltage	+6V
Lead Temperature (soldering, sec.)	260°C
Storage Temperature (T_s)	-65°C to +150°C
ESD Rating ⁽³⁾	
MIC3230	1500V HB, 100VMM
MIC3232	2kV HB, 100VMM
MIC3231	1500V HB, 150VMM

Operating Ratings⁽²⁾

Supply Voltage (V_{IN})	+6V to +45V
Junction Temperature (T_J)	-40°C to +125°C
Junction Thermal Resistance	
MSOP (θ_{JA})	130.5°C/W
EPAD TSSOP (θ_{JA})	36.5°C/W
MLF [®] (θ_{JA})	60.7°C/W

Electrical Characteristics⁽⁴⁾

$V_{IN} = 12V$; $V_{EN} = 3.6V$; $L = 47\mu H$; $C = 4.7\mu F$; $T_J = 25^\circ C$, **Bold** values indicate $-40^\circ C \leq T_J \leq +125^\circ C$, unless noted.

Symbol	Parameter	Condition	Min	Typ	Max	Units
V_{IN}	Supply Voltage Range		6		45	V
UVLO	Under Voltage Lockout		3.5	4.9	5.5	V
I_{VIN}	Quiescent Current	$V_{FB} > 275mV$ (to ensure device is not switching)		3.2	10	mA
I_{SD}	Shutdown Current	$V_{EN} = 0V$		30		μA
V_{IADJ}	Feedback Voltage (at IADJ)	Room temperature (3%)	242.5	250	257.5	mV
		$-40^\circ C \leq T_J \leq +125^\circ C$ (5%)	237.5	250	262.5	mV
I_{ADJ}	Feedback Input Current	$V_{FB} = 250mV$		1.2	3	μA
	Line Regulation	$V_{IN} = 12V$ to 24V		2		%
	Load Regulation	V_{OUT} to $2 \times V_{OUT}$		2		%
D_{MAX}	Maximum Duty Cycle	MIC3230 & MIC3232	90			%
		MIC3231	88			%
V_{EN}	Enable Threshold	Turn ON	1.5	1.15		V
		Turn OFF		1.1	0.4	V
I_{EN}	Enable Pin Current	$V_{EN} = 3.3V$ $R_{EN} = 100k\Omega$		17	30	μA
V_{PWM}	PWMD Threshold	Turn ON	1.5	0.75		V
		Turn OFF		0.7	0.4	V
f_{PWMD}	PWMD Frequency Range	Note 5 ($L = 47\mu H$; $C = 4.7\mu F$)	0		500	Hz
f_{SW}	Programmable Oscillator Frequency	$R_{FREQ} = 82.5k\Omega$		109		kHz
		$R_{FREQ} = 21k\Omega$	360	400	440	kHz
		$R_{FREQ} = 8.25k\Omega$		950		kHz
f_{SW}	Fixed Frequency Option	(MIC3232YMM)	360	400	440	kHz
F_{DITHER}	Low EMI (MIC3231)	Frequency dither shift from nominal		± 12		%
V_{SENS}	Current Limit Threshold Voltage	$R_{SENSE} = 390\Omega$	0.315	0.45	0.585	V
I_{SENSE}	I_{SENSE} Peak Current Out	$R_{SENSE} = 390\Omega$		250		μA

Notes:

- Exceeding the absolute maximum rating may damage the device.
- The device is not guaranteed to function outside its operating rating.
- Devices are ESD sensitive. Handling precautions recommended. Human body model, 1.5k Ω in series with 100pF.
- Specification for packaged product only.
- Guaranteed by design

Electrical Characteristics (Continued)

Symbol	Parameter	Condition	Min	Typ	Max	Units
V _{OVP}	Over Voltage Protection		1.203	1.24	1.277	V
	Driver Impedance	Sink Source		2.4 2	3.5	Ω Ω
V _{DRH}	Driver Voltage High	V _{IN} = 12V	7	9	11	V
T _J	Over-Temperature Threshold Shutdown			150		°C
	Thermal Shutdown	Hysteresis		5		°C

Typical Characteristics

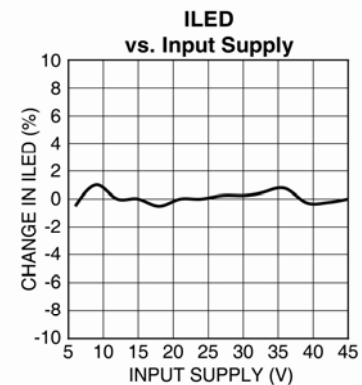
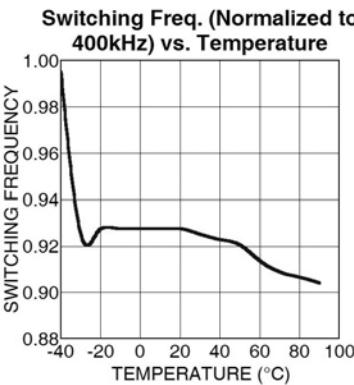
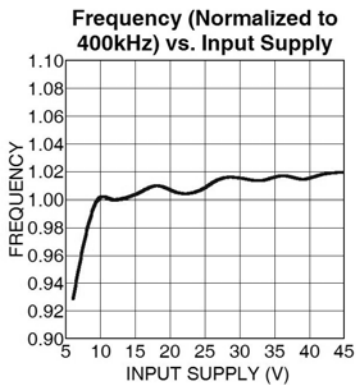
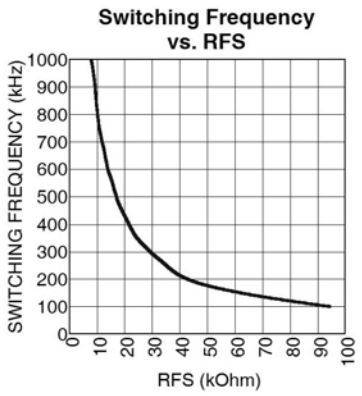
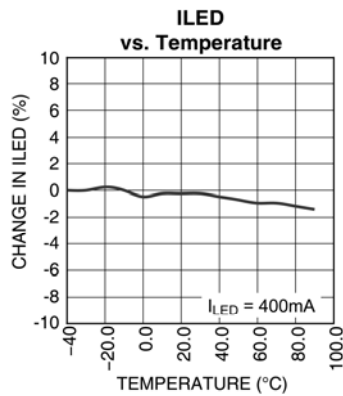
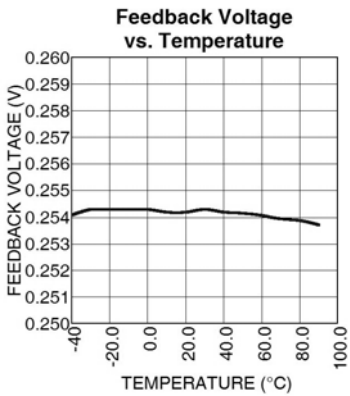
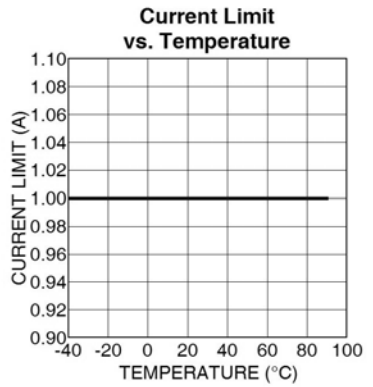
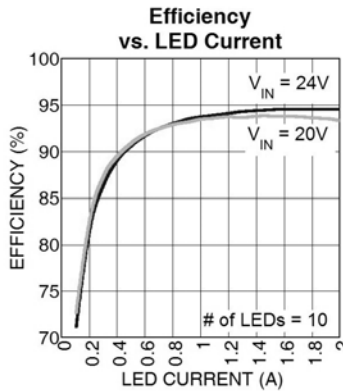
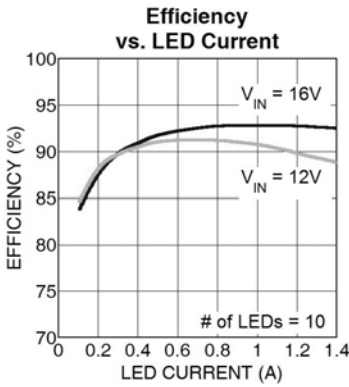
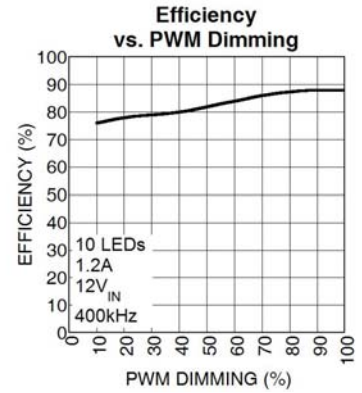
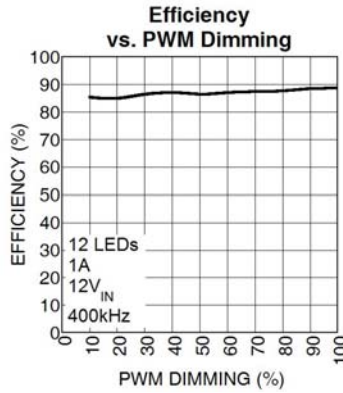
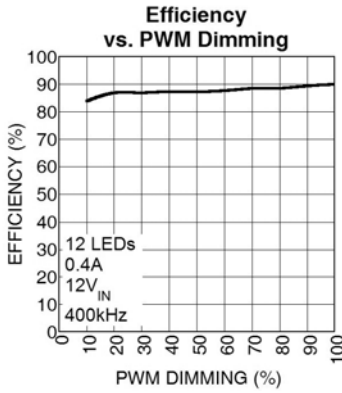

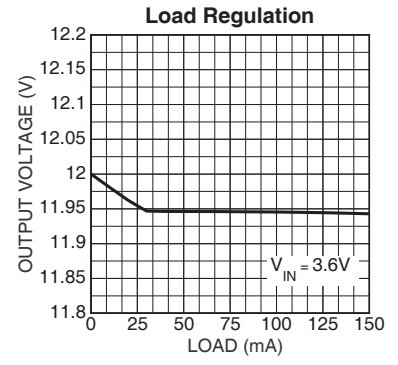
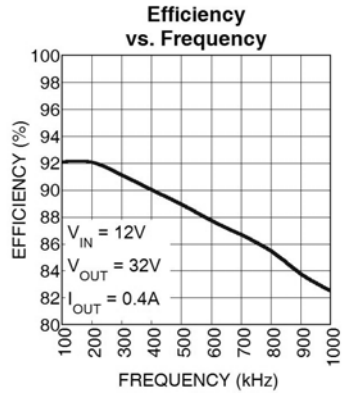
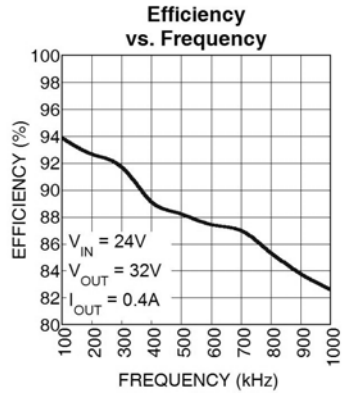

Functional Description

A constant output current converter is the preferred method for driving LEDs. Small variations in current have a minimal effect on the light output, whereas small variations in voltage have a significant impact on light output. The MIC323x family of LED drivers are specifically designed to operate as constant current LED Drivers and the typical application schematic is shown in Figure 1.

The MIC323x family is designed to operate as a boost controller, where the output voltage is greater than the input voltage. This configuration allows for the design of multiple LEDs in series to help maintain color and brightness. The MIC323x family can also be configured as a SEPIC controller, where the output voltage can be either above or below the input voltage.

The MIC3230/1/2 have a very wide input voltage range, between 6V and 45V, to help accommodate for a diverse range of input voltage applications. In addition, the LED current can be programmed to a wide range of values through the use of an external resistor. This provides design flexibility in adjusting the current for a particular application need.

The MIC3230/1/2 features a low impedance gate driver capable of switching large MOSFETs. This low impedance helps provide higher operating efficiency.

The MIC323x family can control the brightness of the LEDs via its PWM dimming capability. Applying a PWM signal (up to 500Hz) to the PWMD pin allows for control of the brightness of the LED.

Each member of the MIC323x family employs peak current mode control. Peak current mode control offers advantages over voltage mode control in the following manner. Current mode control can achieve a superior line transient performance compared to voltage mode control and through small signal analysis (not shown here), current mode control is easier to compensate than voltage mode control, thus allowing for a less complex control loop stability design. Figure 2 shows the functional block diagram.

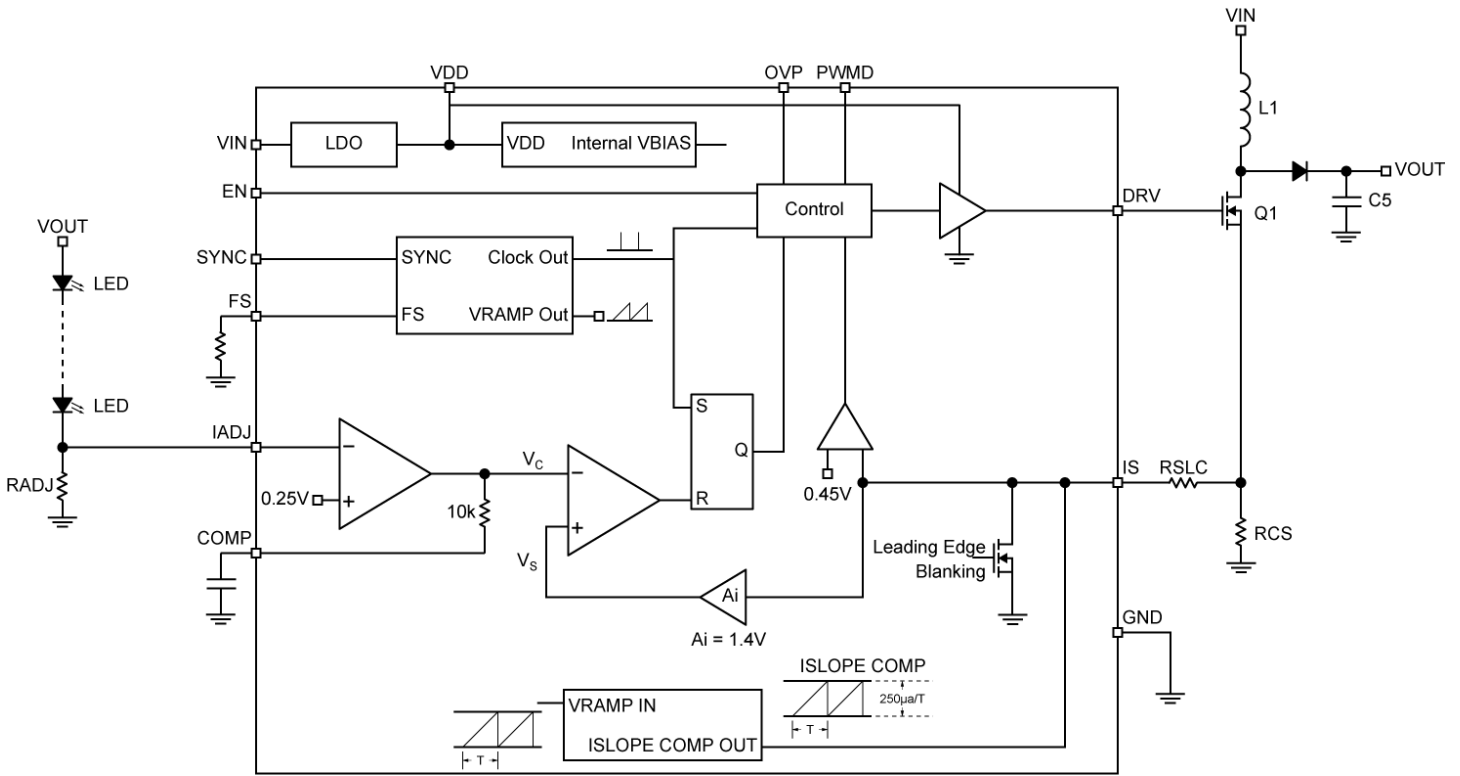

Figure 2. MIC3230 Functional Block Diagram

Power Topology

Constant Output Current Controller

The MIC323x family is peak current mode boost controllers designed to drive high power LEDs. Unlike a standard constant output voltage controller, the MIC323x family has been designed to provide a constant output current. The MIC323x family is designed for a wide input voltage range, from 6V to 45V. In the boost configuration, the output can be set from V_{IN} up to 100V.

As a peak current mode controller, the MIC323x family provides the benefits of superior line transient response as well as an easier to design compensation.

This family of LED drivers features a built-in soft-start circuitry in order to prevent start-up surges. Other protection features include:

- Current Limit (I_{LIMIT}) - Current sensing for over current and overload protection
- Over Voltage Protection (OVP) - Output over voltage protection to prevent operation above a safe upper limit
- Under Voltage Lockout (UVLO) – UVLO designed to prevent operation at very low input voltages

Setting the LED Current

The current through the LED string is set via the value chosen for the current sense resistor, R_{ADJ} . This value can be calculated using Equation 1:

$$\text{Eq. (1)} \quad I_{LED} = \frac{0.25V}{R_{ADJ}}$$

Another important parameter to be aware of in the boost controller design is the ripple current. The amount of ripple current through the LED string is equal to the output ripple voltage divided by the LED AC resistance (R_{LED} – provided by the LED manufacturer) plus the current sense resistor (R_{ADJ}). The amount of allowable ripple through the LED string is dependent upon the application and is left to the designer's discretion. This equation is shown in Equation 2:

$$\text{Eq. (2)} \quad \Delta I_{LED} \approx \frac{V_{OUT_RIPPLE}}{(R_{LED} + R_{ADJ})}$$

$$\text{Where} \quad V_{OUT_RIPPLE} = \frac{I_{LED} \times D \times T}{C_{OUT}}$$

Reference Voltage

The voltage feedback loop of the MIC323x uses an internal reference voltage of 0.25V with an accuracy of $\pm 3\%$. The feedback voltage is the voltage drop across the current setting resistor (R_{ADJ}) as shown in Figure 1. When in regulation the voltage at I_{ADJ} will equal 0.25V.

Output Over Voltage Protection (OVP)

The MIC323x provides an OVP circuitry in order to help protect the system from an overvoltage fault condition. This OVP point can be programmed through the use of external resistors ($R8$ and $R9$ in Figure 1). A reference value of 1.245V is used for the OVP. Equation 3 can be used to calculate the resistor value for $R9$ to set the OVP point.

$$\text{Eq. (3)} \quad R9 = \frac{R8}{(V_{OVP} / 1.245) - 1}$$

LED Dimming

The MIC323x family of LED drivers can control the brightness of the LED string via the use of pulse width modulated (PWM) dimming. A PWM input signal of up to 500Hz can be applied to the PWM DIM pin (see Figure 1) to pulse the LED string ON and OFF. It is recommended to use PWM dimming signals above 120Hz to avoid any recognizable flicker by the human eye. PWM dimming is the preferred way to dim a LED in order to prevent color/wavelength shifting, as occurs with analog dimming. The output current level remains constant during each PWM pulse.

Oscillator and Switching Frequency Selection

The MIC323x family features an internal oscillator that synchronizes all of the switching circuits internal to the IC. This frequency is adjustable on the MIC3230 and MIC3231 and fixed at 400kHz in the MIC3232.

In the MIC3230/1, the switching frequency can be set by choosing the appropriate value for the resistor, R_1 according to Equation 4:

$$\text{Eq. (4)} \quad R_{FS} (k\Omega) = \left(\frac{7526}{F_{SW} (kHz)} \right)^{1.035}$$

SYNC (MIC3230 Only)

Multiple MIC3230 ICs can be synchronized by connecting their SYNC pins together. When synchronized, the MIC3230 with the highest frequency (master) will override the other MIC3230s (slaves). The internal oscillator of the master IC will override the oscillator of the slave part(s) and all MIC3230 will be synchronized to the same master switching frequency.

The SYNC pin is designed to be used only by other MIC3230s and is available on the MIC3230 only. If the SYNC pin is being unused, it is to be left floating (open). In the MIC3231, the SYNC pin is to be left floating (open).

Dithering (MIC3231 Only)

The MIC3231 has a feature which dithers the switching frequency by ±12%. The purpose of this dithering is to help achieve a spread spectrum of the conducted EMI noise. This can allow for an overall reduction in noise emission by approximately 10dB.

Internal Gate Driver

External FETs are driven by the MIC323x's internal low impedance gate drivers. These drivers are biased from the V_{DD} and have a source resistance of 2Ω and a sink resistance of 3.5Ω.

V_{DD}

V_{DD} is an internal linear regulator powered by V_{IN} and V_{DD} is the bias supply for the internal circuitry of the MIC323x. A 10μF ceramic bypass capacitor is required at the V_{DD} pin for proper operation. This pin is for filtering only and should not be utilized for operation.

Current Limit

The MIC323x family features a current limit protection feature to prevent any current runaway conditions. The current limit circuitry monitors current on a pulse by pulse basis. It limits the current through the inductor by sensing the voltage across R_{CS}. When 0.45V is present at the IS pin, the pulse is truncated. The next pulse continues as normally until the IS pin reaches 0.45V and it is truncated once again. This will continue until the output load is decreased.

Select R_{CS} using Equation 5:

$$\text{Eq. (5)} \quad R_{CS} = \frac{0.45}{(V_{OUT_MAX} - V_{IN_MIN}) \times D} + I_{L_PK_LIMIT} / (L \times F_{SW})$$

Slope Compensation

The MIC323x is a peak current mode controller and requires slope compensation. Slope compensation is required to maintain internal stability across all duty cycles and prevent any unstable oscillations. The MIC323x uses slope compensation that is set by an external resistor, R_{SLC}. The ability to set the proper slope compensation through the use of a single external component results in design flexibility. This slope compensation resistor, R_{SLC}, can be calculated using Equation 6:

$$\text{Eq. (6)} \quad R_{SLC} = \frac{(V_{OUT_MAX} - V_{IN_MIN}) \times R_{CS}}{L \times 250 \mu A \times F_{SW}}$$

where V_{IN_MAX} and V_{OUT_MAX} can be selected to system specifications.

Current Sense I_S

The IS pin monitors the rising slope of the inductor current (m1 in Figure 5) and also sources a ramp current (250μA/T) that flows through R_{SLC} that is used for slope compensation. This ramp of 250μA per period, T, generates a ramped voltage across R_{SLC} and is labeled V_A in Figure 3. The signal at the IS pin is the sum of V_{CS} + V_A (as shown in Figure 3). The current sense circuitry and block diagram is displayed in Figure 4. The IS pin is also used as the current limit (see the previous section on Current Limit).

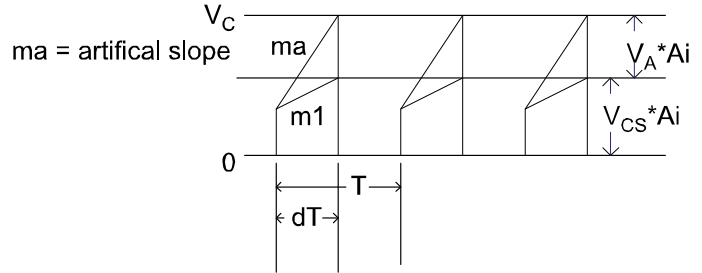

Figure 3. Slope Compensation Waveforms

Soft Start

The boost switching convertor features a soft start in order to power up in a controlled manner, thereby limiting the inrush current from the line supply. Without this soft start, the inrush current could be too high for the supply. To prevent this, a soft start delay can be set using the compensation capacitor (C_{COMP} in Figure 1). For switching to begin, the voltage on the compensation cap must reach about 0.7V. Switching starts with the minimum duty cycle and increases to the final duty cycle. As the duty cycle increases, V_{OUT} will increase from V_{IN} to its final value. A 6μA current source charges the compensation capacitor and the soft start time can be calculated in Equation 7:

$$\text{Eq. (7)} \quad T_{SOFTSTART} \approx \frac{C_{COMP} \times V_{COMP_STEADY_STATE}}{6 \mu A}$$

V_{COMP_STEADY_STATE} is usually between 0.7V to 3V, but can be as high as 5V.

$$\text{Eq. (8)} \quad V_{COMP_STEADY_STATE} = Ai \times (V_{APK} + V_{CS_PK})$$

Where: $V_{APK} = \frac{I_{RAMP}}{T} \times R_{SLC} \times D \times T$ and

$$V_{CS_PK} = I_{L_PK} \times R_{CS}$$

$$Ai = 1.4 \text{ V/V}$$

$$D = \text{Duty cycle (0 to 1)}$$

$$T = \text{period}$$

A 10nF ceramic capacitor will make this system stable at all operating conditions.

Leading Edge Blanking

Large transient spikes due to the reverse recovery of the diode may be present at the leading edge of the current sense signal. (Note: drive current can also cause such spikes) For this reason a switch is employed to blank the first 100ns of the current sense signal. See Figure 6.

Eq. (9)
$$I_{IN_RMS} = \frac{V_{OUT} \times I_{OUT}}{eff \times V_{IN}}$$

Eq. (10)
$$I_{IN_AVE} = \sqrt{(I_{IN_RMS})^2 - \frac{(I_{IN_PP})^2}{12}}$$

Eq. (11)
$$I_{IN_PEAK} = I_{IN_AVE} + \frac{I_{IN_PP}}{2}$$

Note: If I_{IN_PP} is small then I_{IN_AVE} nearly equals I_{IN_RMS}

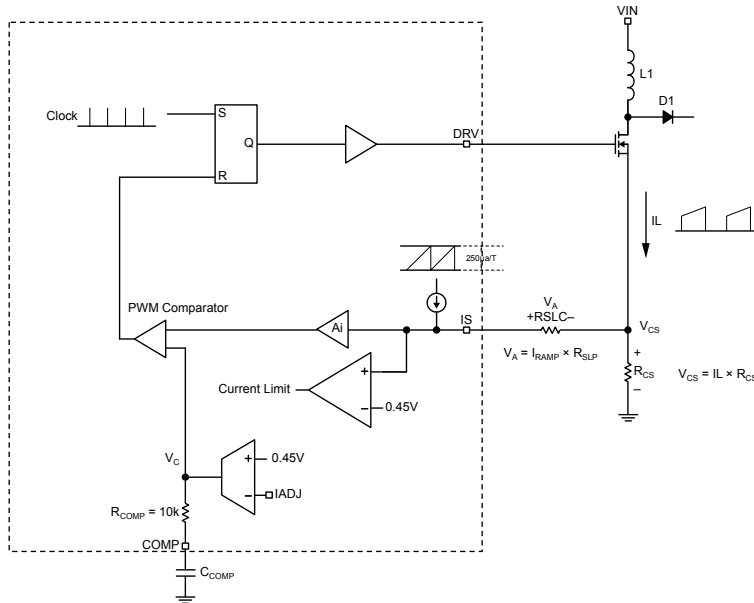

Figure 4. Current Sense Circuit (An explanation of the IS pin)

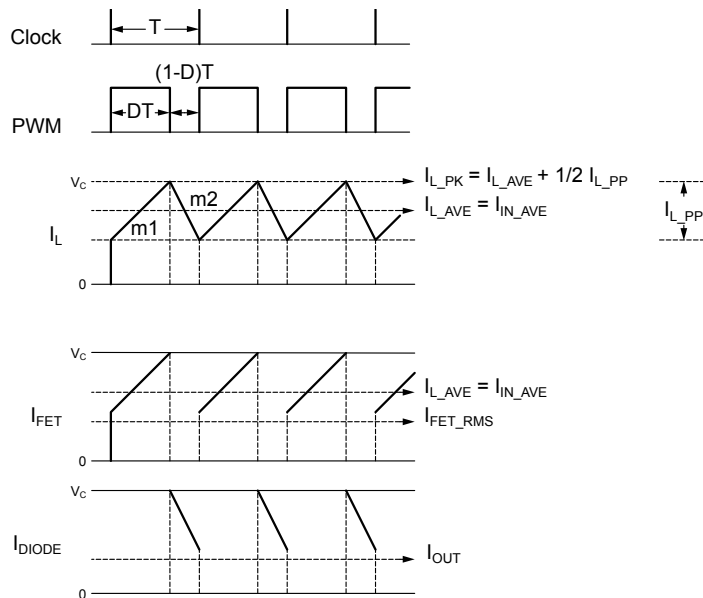

Figure 5. Current Waveforms

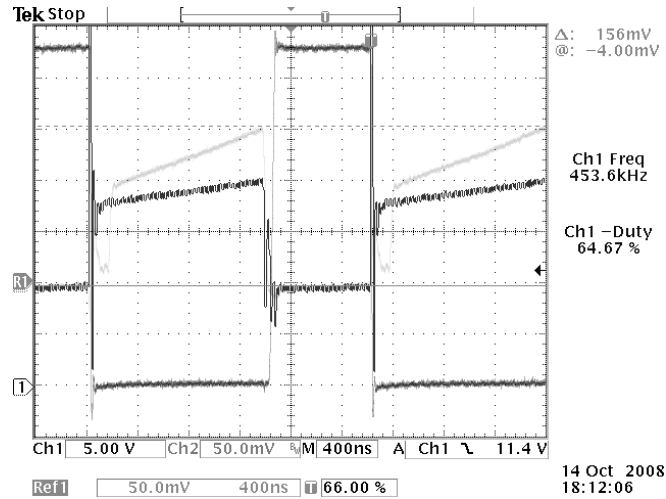

Figure 6. IS Pin and V_{RCS} (Ch1 = Switch Node, Ch2 = IS Pin, Ref1 = V_{CS})

Design Procedure for a LED Driver

Symbol	Parameter	Min	Nom	Max	Units
	Input				
V_{IN}	Input Voltage	8	12	14	V
I_{IN}	Input current			2	A
	Output				
LEDs	Number of LEDs	5	6	7	
V_F	Forward voltage of LED	3.2	3.5	4.0	V
V_{OUT}	Output voltage	16	21	28	V
I_{LED}	LED current	0.33	0.35	0.37	A
I_{PP}	Required I Ripple		40		mA
PWMD	PWM Dimming	0		100	%
OVP	Output over voltage protection		30		V
	System				
F_{SW}	Switching frequency		500kHz		
eff	Efficiency		80		%
V_{DIODE}	Forward drop of schottky diode		0.6		V

Table 2. Design Example Parameters

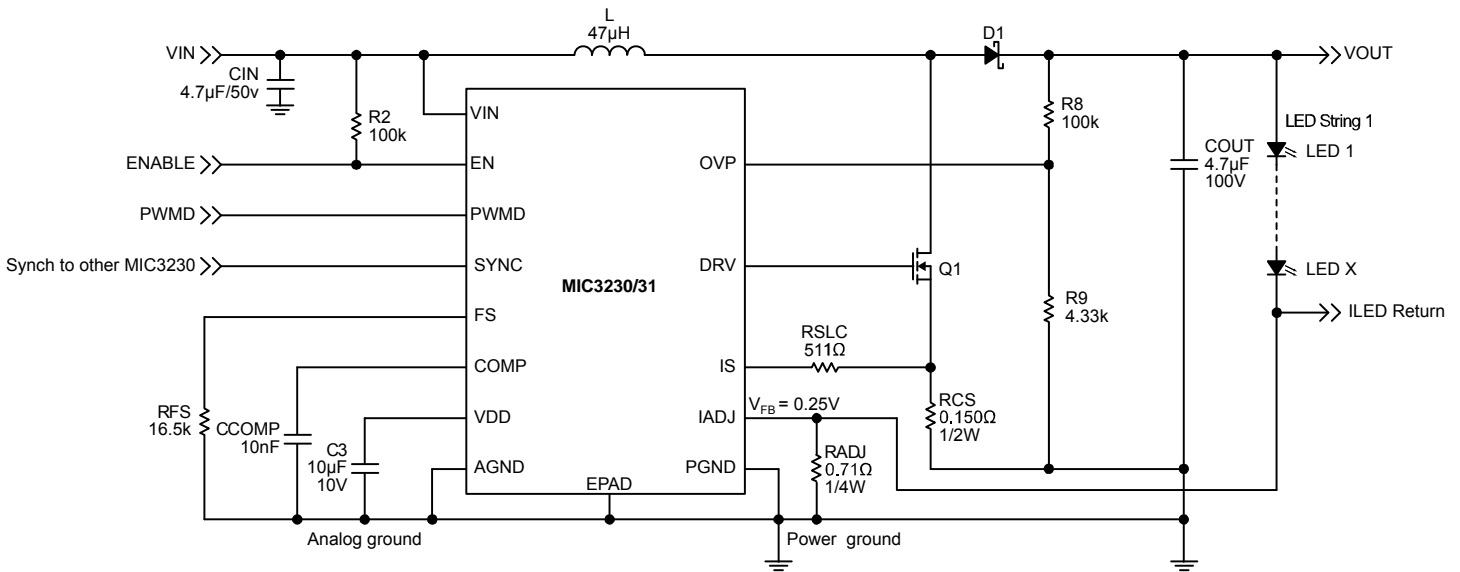

Figure 7. Design Example Schematic

Design Example

In this example, we will be designing a boost LED driver operating off a 12V input. This design has been created to drive six LEDs at 350mA with a ripple of about 12%. We are designing for 80% efficiency at a switching frequency of 500kHz.

Select R_{FS}

To operate at a switching frequency of 500kHz, the R_{FS} resistor must be chosen using Equation 3.

$$R_{FS}(k\Omega) = \frac{(7526)^{1.035}}{500} = 16.6k\Omega$$

Use the closest standard value resistor of 16.5kΩ.

Select R_{ADJ}

Having chosen the LED drive current to be 350mA in this example, the current can be set by choosing the RADJ resistor from Equation 1:

$$R_{ADJ} = \frac{0.25V}{0.35A} = 0.71\Omega$$

The power dissipation in this resistor is:

$$P(R_{ADJ}) = I^2 * R_{ADJ} = 87mW$$

Use a resistor rated at ¼ watt or higher. Choose the closest value from a resistor manufacture.

Operating Duty Cycle

The operating duty cycle can be calculated using Equation 12 provided below:

Eq. (12)
$$D = \frac{(V_{out} - eff \times V_{in} + V_{diode})}{V_{out} + V_{diode}}$$

These can be calculated for the nominal (typical) operating conditions, but should also be understood for the minimum and maximum system conditions as listed below.

$$D_{nom} = \frac{(V_{out_{nom}} - eff \times V_{in_{nom}} + V_{schottky})}{V_{out_{nom}} + V_{schottky}}$$

$$D_{max} = \frac{(V_{out_{max}} - eff \times V_{in_{min}} + V_{schottky})}{V_{out_{max}} + V_{schottky}}$$

$$D_{min} = \frac{(V_{out_{min}} - eff \times V_{in_{max}} + V_{schottky})}{V_{out_{min}} + V_{schottky}}$$

Therefore D_{NOM} =56% D_{MAX} = 78% and D_{MIN} = 33%

Inductor Selection

First, it is necessary to calculate the RMS input current (nominal, min and max) for the system given the operating conditions listed in the design example table. This minimum value of the RMS input current is necessary to ensure proper operation. Using Equation 9, the following values have been calculated:

$$I_{IN_RMS_max} = \frac{V_{OUT_max} \times I_{OUT_max}}{eff \times V_{IN_min}} = 1.64A_rms$$

$$I_{IN_RMS_nom} = \frac{V_{OUT_nom} \times I_{OUT_nom}}{eff \times V_{IN_nom}} = 0.78A_rms$$

$$I_{IN_RMS_min} = \frac{V_{OUT_min} \times I_{OUT_min}}{eff \times V_{IN_max}} = 0.48A_rms$$

I_{out} is the same as I_{LED}

Selecting the inductor current (peak-to-peak), I_{L_PP}, to be between 20% to 50% of I_{IN_RMS_nom}, in this case 40%, we obtain:

$$I_{in_PP_nom} = 0.4I_{in_rms_nom} = 0.4 * 0.78 = 0.31A_{P-P}$$

(see the current waveforms in Figure 5).

It can be difficult to find large inductor values with high saturation currents in a surface mount package. Due to this, the percentage of the ripple current may be limited by the available inductor. It is recommended to operate in the continuous conduction mode. The selection of L described here is for continuous conduction mode.

$$\text{Eq. (13)} \quad L = \frac{V_{IN} \times D \times T}{I_{in_PP}}$$

Using the nominal values, we get:

$$L = \frac{12V \times 0.56 \times 2\mu s}{0.31A} = 43\mu H$$

Select the next higher standard inductor value of 47μH. Going back and calculating the actual ripple current gives:

$$\text{Eq. (13a)} \quad I_{in_PP} = \frac{V_{IN_nom} \times D_{nom} \times T}{L} = \frac{12V \times 0.56 \times 2\mu s}{47\mu H} = 0.29A_{PP}$$

The average input current is different than the RMS input current because of the ripple current. If the ripple current is low, then the average input current nearly equals the RMS input current. In the case where the average input current is different than the RMS, Equation 10 shows the following:

$$\text{Eq. (13b)} \quad I_{IN_AVE_max} = \sqrt{(I_{IN_RMS_max})^2 - \frac{(I_{IN_PP})^2}{12}}$$

$$I_{IN_AVE_max} = \sqrt{(1.64)^2 - (0.29)^2 / 12} \approx 1.64A$$

The Maximum Peak input current I_{L_PK} can found using equation 11:

$$I_{L_PK_max} = I_{IN_AVE_max} + 0.5 \times I_{L_PP_max} = 1.78A$$

The saturation current (I_{SAT}) at the highest operating temperature of the inductor must be rated higher than this.

The power dissipated in the inductor is:

$$\text{Eq. (13c)} \quad P_{INDUCTOR} = I_{in_RMS_max}^2 \times DCR$$

Current Limit and Slope Compensation

Having calculated the I_{L_pk} above, We can set the current limit 20% above this maximum value:

$$I_{L_pkLimit} = 1.2 \times 1.6A = 1.9A$$

The internal current limit comparator reference is set at 0.45V, therefore when $V_{IS_PIN} = 0.45$, the IC enters current limit.

$$\text{Eq. (14)} \quad 0.45 = (V_{A_{PK}} + V_{CS_{PK}})$$

Where $V_{A_{PK}}$ is the peak of the V_A waveform and $V_{CS_{PK}}$ is the peak of the V_{cs} waveform

$$\text{Eq. (14a)} \quad 0.45 = I_{RAMP} \times R_{SLC} \times D + I_{L_pkLimit} \times R_{CS}$$

To calculate the value of the slope compensation resistance, R_{SLC} , we can use Equation 5:

$$R_{SLC} = \frac{(V_{OUT_MAX} - V_{IN_MIN}) \times R_{CS}}{L \times 250\mu A \times F_{SW}}$$

First we must calculate R_{CS} , which is given below in Equation 15:

$$\text{Eq. (15)} \quad R_{CS} = \frac{0.45}{\frac{(V_{OUT_MAX} - V_{IN_MIN}) \times D_{max}}{L \times F_{SW}} + I_{L_pkLimit}}$$

Therefore;

$$R_{CS} = \frac{0.45}{\frac{(28V - 8V) \times (0.50)}{47\mu H \times 500kHz} + 1.9A} = 179m\Omega$$

Using a standard value 150mΩ resistor for R_{CS} , we obtain the following for R_{SLC} :

$$R_{SLC} = \frac{(28 - 8) \times 150m\Omega}{47\mu H \times 250\mu A \times 500kHz} = 511\Omega$$

Use the next higher standard value if this not a standard value. In this example 511Ω is a standard value.

Check: Because we must use a standard value for R_{CS} and R_{SLC} ; $I_{L_pkLimit}$ may be set at a different level (if the calculated value isn't a standard value) and we must calculate the actual $I_{L_pkLimit}$ value (remember $I_{L_pkLimit}$ is the same as $I_{in_pkLimit}$).

Rearranging Equation 14a to solve for $I_{L_pkLimit}$:

$$I_{in_pkLimit} = \frac{(0.45 - I_{RAMP} \times R_{SLC} \times D)}{R_{CS}}$$

$$I_{in_actualLimit} = \frac{(0.45 - 250\mu A \times 511 \times 0.75)}{.150} = 2.34A$$

This is higher than the initial $1.2 \times I_{L_pk_max} = 1.9A$ limit because we have to use standard values for R_{CS} and for R_{SLC} . If $I_{in_actualLimit}$ is too high than use a higher value for R_{CS} . The calculated value of R_{CS} for a 1.9A current limit was 179mΩ. In this example, we have chosen a lower value which results in a higher current limit. If we use a higher standard value the current limit will have a lower value. The designer does not have the same choices for small valued resistors as with larger valued resistors. The choices differ from resistor manufacturers. If too large a current sense resistor is selected, the maximum output power may not be able to be achieved at low input line voltage levels. Make sure the inductor will not saturate at the actual current limit $I_{in_actualLimit}$.

Perform a check at $I_{IN}=2.34A_{pk}$.

$$V_{IS_PIN} = 250\mu A \times (0.78) \times 511\Omega + 2.34A \times 150m\Omega = 0.45V$$

Maximum Power dissipated in R_{CS} is;

$$\text{Eq. (17)} \quad P_{R_{CS}} = I_{R_{CS_RMS}}^2 \times R_{CS}$$

$$\text{Eq. (18)} \quad I_{R_{CS_RMS_max}} = I_{FET_RMS_max} = \sqrt{D \left(I_{IN_AVE_max}^2 + \frac{I_{L_PP}^2}{12} \right)}$$

$$I_{R_{CS_RMS}} = \sqrt{0.78 \left(1.64^2 + \frac{0.26^2}{12} \right)} = 1.44 A_{rms}$$

$$P_{R_{CS}} = 1.25^2 \times 0.15 = 0.31 \text{ watt}$$

Use a 1/2 Watt resistor for R_{CS} .

Output Capacitor

In this LED driver application, the ILED ripple current is a more important factor compared to that of the output ripple voltage (although the two are directly related). To find the C_{OUT} for a required ILED ripple use the following calculation:

For an output ripple $I_{LED_ripple} = 20\%$ of I_{LED_nom}

$$I_{LED_ripple} = 0.2 \times 0.35 = 70 \text{ mA}$$

$$\text{Eq. (19)} \quad C_{out} = \frac{I_{LED_nom} * D_{nom} * T}{I_{LED_ripple} * (R_{adj} + R_{LED_total})}$$

Find the equivalent ac resistance R_{LED_ac} from the datasheet of the LED. This is the inverse slope of the ILED vs. V_F curve i.e.:

$$\text{Eq. (20)} \quad R_{LED_ac} = \frac{\Delta V_F}{\Delta I_{LED}}$$

In this example, use $R_{LED_ac} = 0.1\Omega$ for each LED.

If the LEDs are connected in series, multiply $R_{LED_ac} = 0.1\Omega$ by the total number of LEDs. In this example of 6 LEDs, we obtain the following:

$$R_{LED_total} = 6 \times 0.1\Omega = 0.6\Omega$$

$$C_{out} = \frac{I_{LED_nom} * D_{nom} * T}{I_{LED_ripple} * (R_{adj} + R_{LED_total})} = 4.1\mu F$$

Use the next highest standard value, which is $4.7\mu F$.

There is a trade off between the output ripple and the rising edge of the PWM pulse. This is because between PWM dimming pulses, the converter stops pulsing and C_{OUT} will start to discharge. The amount that C_{OUT} will discharge depends on the time between PWM Dimming pulses. At the next PWM pulse C_{OUT} has to be charged up to the full output voltage V_{OUT} before the desired LED current flows.

Input Capacitor

The input current is shown in Figure 5. For superior performance, ceramic capacitors should be used because of their low equivalent series resistance (ESR). The input ripple current is equal to the ripple in the inductor plus the ripple voltage across the input capacitor, which is the ESR of C_{IN} times the inductor ripple. The input capacitor will also bypass the EMI generated by the converter as well as any voltage spikes generated by the inductance of the input line. For a required V_{IN_RIPPLE} :

Eq. (21)

$$C_{IN} = \frac{I_{IN_PP}}{8 \times V_{IN_RIPPLE} \times F_{SW}} = \frac{(0.28A)}{8 \times 50mV \times 500kHz} = 1.4\mu F$$

This is the minimum value that should be used. The input capacitor should also be rated for the maximum RMS input current. To protect the IC from inductive spikes or any overshoot, a larger value of input capacitance may be required and it is recommended that ceramic capacitors be used. In this design example a value of $4.7\mu F$ ceramic capacitor was selected.

MOSFET Selection

In this design example, the FET has to hold off an output voltage maximum of 30V. It is recommended to use an 80% de-rating value on switching FETs, so a minimum of a 38V FET should be selected. In this design example, a 75V FET has been selected.

The switching FET power losses are the sum of the conduction loss and the switching loss:

$$\text{Eq. (22)} \quad P_{FET} = P_{FET_COND} + P_{FET_SWITCH}$$

The conduction loss of the FET is when the FET is turned on. The conduction power loss of the FET is found by the following equation:

$$\text{Eq. (23)} \quad P_{FET_COND} = I_{FET_RMS}^2 \times R_{DS(on)}, \text{ where}$$

$$I_{FET_RMS} = \sqrt{D \left(I_{IN_AVE}^2 + \frac{I_{L_PP}^2}{12} \right)}$$

The switching losses occur during the switching transitions of the FET. The transition times, $t_{transition}$, are the times when the FET is turning off and on. There are two transition times per period, T. It is important not to confuse T (the period) with the transition time, $t_{transition}$.

$$\text{Eq. (24)} \quad T = \frac{1}{F_{SW}}$$

Eq. (25)

$$P_{FET_SWITCH_max} = I_{FET_AVE_max} \times V_{OUT_max} \times t_{transition_max} \times F_{SW}$$

To find $t_{transition_max}$:

$$\text{Eq. (26)} \quad t_{\text{transition_max}} \approx \frac{Qg}{I_{\text{gatedrv}}}$$

where Qg is the total gate charge of the external MOSFET provided by the MOSFET manufacturer and the Qg should be chosen at a $V_{GS} \approx 10V$. This is not an exact value, but is more of an estimate of $t_{\text{transition_max}}$.

The FET manufacturers' provide a gate charge at a specified V_{GS} voltage:

$$C_{In_FET} = \frac{Q_G}{@V_{GS}}$$

This is the FET's input capacitance. Select a FET with $R_{DS(on)}$ and Q_G such that the external power is below about 0.7W for a SO-8 or about 1W for a PowerPak (FET package). The Vishay Siliconix Si7148DP in a PowerPak SO-8 package is one good choice. The internal gate driver in the MIC3230/1/2 is 2A. From the Si7148DP data sheet:

$$R_{DS(on),25^\circ C} = 0.0145\Omega$$

$$\text{Total gate Charge} = 68nC \text{ (typical)}$$

The $R_{DS(on)}$ (temp) is a function of temperature. As the temperature in the FET increases so does the $R_{DS(on)}$.

To find $R_{DS(on)}$ (temp) use Equation 27, or simply double the $R_{DS(on)}(25^\circ C)$ for $R_{DS(on)}(125^\circ C)$.

$$\text{Eq. (27)} \quad R_{DS(on)}(\text{temp}) = R_{DS(on)}(25^\circ C) \times (1.007^{(\text{Temp}-25^\circ)})$$

The $R_{DS(on)}$ (temp) at $125^\circ C$ is:

$$R_{DS(on)}(125^\circ C) = 0.0145 \times (1.007^{(125^\circ - 25^\circ)}) \approx 30m\Omega$$

$$\text{From Equation 23: } P_{FET_COND} = 1.64^2 \times 30m\Omega = 62mW$$

$$\text{From Equation 26: } t_{\text{transition}} \approx \frac{Qg}{I_{\text{gatedrv}}} = \frac{68nC}{2A} = 34ns$$

$$I_{FET_AVE_max} = 1.64A$$

$$V_{OUT_max} = 28V$$

From Equation 25:

$$P_{FET_SWITCH_max} = 1.64A \times 28V \times 34ns \times 500kHz = 0.78Watts$$

From Equation 22

$$P_{FET} = 62mW + 0.78W = 0.84W$$

This is about the limit for a part on a circuit board without having to use any additional heat sinks.

Rectifier Diode

A Schottky Diode is best used here because of the lower forward voltage and the low reverse recovery time. The

voltage stress on the diode is the max V_{OUT} and therefore a diode with a higher rating than max V_{OUT} should be used. An 80% de-rating is recommended here as well.

$$\text{Eq (28)} \quad P_{diode} \approx V_{SCHOTTKY} \times I_{OUT_max}$$

$$\text{Eq. (29)} \quad \begin{aligned} P_{diode} &\approx V_{SCHOTTKY} \times I_{LED_max} \\ P_{diode} &\approx 0.25W \end{aligned}$$

MIC3230 Power Losses

The power losses in the MIC3230 are:

$$\text{Eq.(30)} \quad P_{MIC3230} = Q_{gate} \times V_{gate} \times F + I_Q \times V_{in}$$

where Q_{gate} is the total gate charge of the external MOSFET. V_{gate} is the gate drive voltage of the MIC3230.

F is the switching frequency. I_Q is the quiescent current of the MIC3230 found in the electrical characterization table. $I_Q = 3.2mA$. V_{IN} is the voltage at the V_{IN} pin of the MIC3230. From Eq.(30)

$$P_{MIC3230} = 68nF \times 12 \times 500kHz + 3.2mA \times 14 = 0.45W$$

OVP-Over voltage protection

Set OVP higher than the maximum output voltage by at least one volt. To find the resistor divider values for OVP use Equation 3 and set the OVP=30V and $R8=100k\Omega$:

$$R9 = \frac{100k\Omega \times 1.245}{30 - 1.245} = 4.33k\Omega$$

PCB Layout

1. All typologies of DC-to-DC converters have a reverse recovery current (RRC) of the flyback or (freewheeling) diode. Even a Schottky diode, which is advertised as having zero RRC, it really is not zero. The RRC of the freewheeling diode in a boost converter is even greater than in the Buck converter. This is because the output voltage is higher than the input voltage and the diode has to charge up to $-V_{OUT}$ during each on-time pulse and then discharge to V_F during the off-time.

2. Even though the RRC is very short (tens of nanoseconds) the peak currents are high (multiple amperes). The high RRC causes a voltage drop on the ground trace of the PCB and if the converter control IC is referenced to this voltage drop, the output regulation will suffer.

3. It is important to connect the IC's reference to the same point as the output capacitors to avoid the voltage drop caused by RRC. This is also called a star connection or single point grounding.

4. Feedback trace: The high impedance traces of the FB should be short.

Package Information

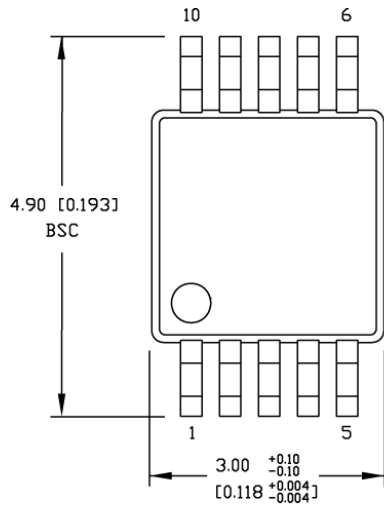

TOP VIEW

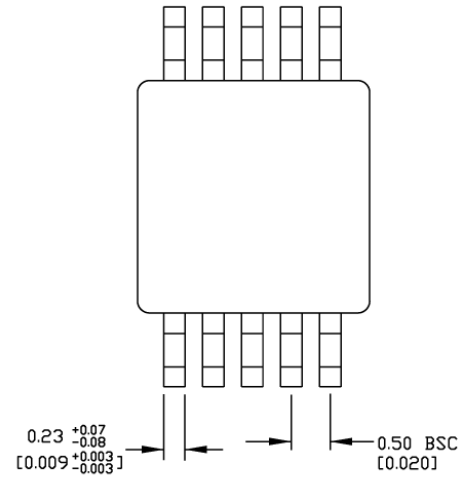

BOTTOM VIEW

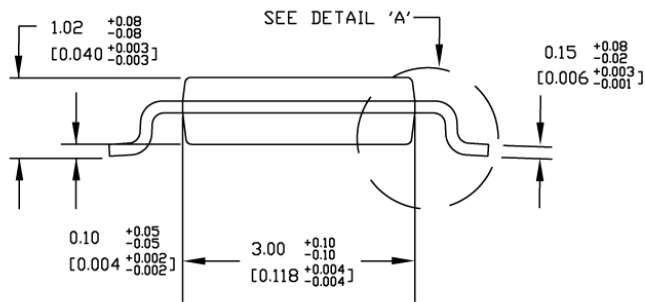

SIDE VIEW

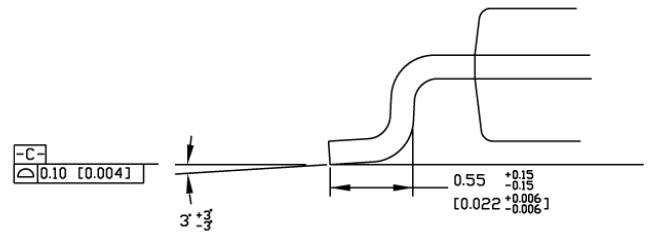

DETAIL A

NOTES:

1. DIMENSIONS ARE IN MM [INCHES].
2. CONTROLLING DIMENSION: MM
3. DIMENSION DOES NOT INCLUDE MOLD FLASH OR PROTRUSION EITHER OF WHICH SHALL NOT EXCEED 0.20 [0.008] PER SIDE.

10-Pin MSOP (MM)

Pin #1 ID
By Marking

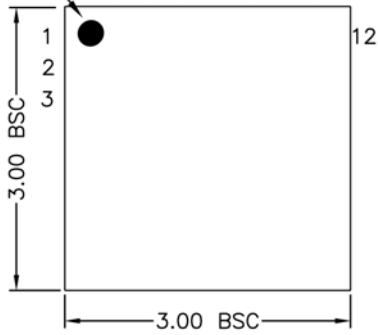

TOP VIEW

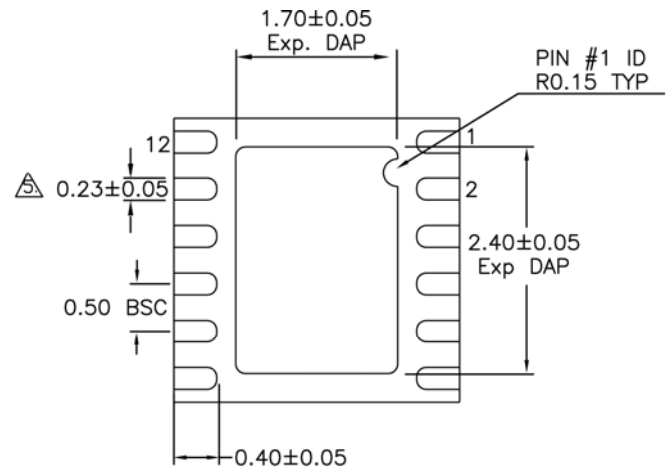

BOTTOM VIEW

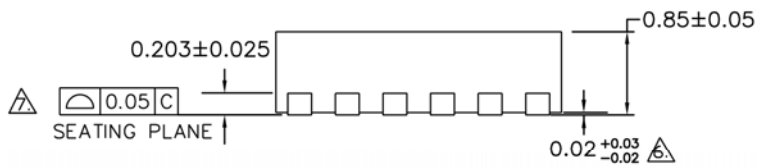

SIDE VIEW

NOTE:

1. ALL DIMENSIONS ARE IN MILLIMETERS.
 2. MAX. PACKAGE WARPAGE IS 0.05 mm.
 3. MAXIMUM ALLOWABLE BURRS IS 0.076 mm IN ALL DIRECTIONS.
 4. PIN #1 ID ON TOP WILL BE LASER/INK MARKED.
- ⚠ DIMENSION APPLIES TO METALIZED TERMINAL AND IS MEASURED BETWEEN 0.20 AND 0.25 mm FROM TERMINAL TIP.
- ⚠ APPLIED ONLY FOR TERMINALS.
- ⚠ APPLIED FOR EXPOSED PAD AND TERMINALS.

12-Pin 3mm x 3mm MLF[®] (ML)

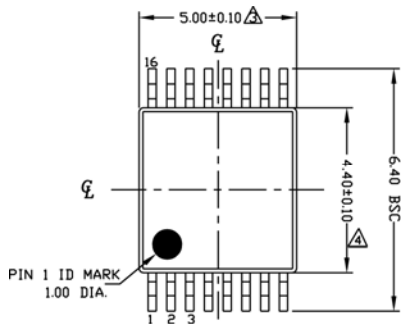

TOP VIEW

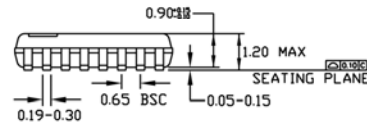

SIDE VIEW

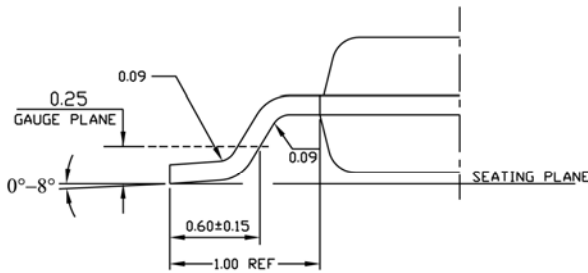

DETAIL 'A'

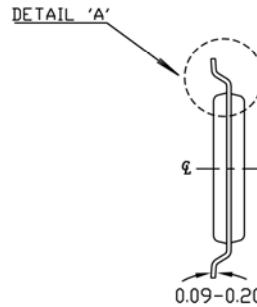

END VIEW

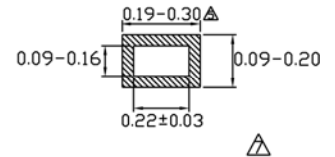

LEAD TIP DETAIL

Notes

1. ALL DIMENSIONS ARE IN MILLIMETERS (ANGLES IN DEGREES).
2. DIMENSIONING AND TOLERANCING PER ANSI Y14.5M-1994.
- △ DIMENSION DOES NOT INCLUDE MOLD FLASH, PROTRUSIONS OR GATE BURRS.
- △ DIMENSION DOES NOT INCLUDE INTERNAL FLASH OR PROTRUSION.
- △ DIMENSION DOES NOT INCLUDE DAMBAR PROTRUSION.
- △ CROSS SECTION TO BE DETERMINED AT 0.10 TO 0.25MM FROM THE LEAD TIP.

16-Pin Exposed Pad TSSOP (TSE)

MICREL, INC. 2180 FORTUNE DRIVE SAN JOSE, CA 95131 USA
 TEL +1 (408) 944-0800 FAX +1 (408) 474-1000 WEB <http://www.micrel.com>

Micrel makes no representations or warranties with respect to the accuracy or completeness of the information furnished in this data sheet. This information is not intended as a warranty and Micrel does not assume responsibility for its use. Micrel reserves the right to change circuitry, specifications and descriptions at any time without notice. No license, whether express, implied, arising by estoppel or otherwise, to any intellectual property rights is granted by this document. Except as provided in Micrel's terms and conditions of sale for such products, Micrel assumes no liability whatsoever, and Micrel disclaims any express or implied warranty relating to the sale and/or use of Micrel products including liability or warranties relating to fitness for a particular purpose, merchantability, or infringement of any patent, copyright or other intellectual property right.

Micrel Products are not designed or authorized for use as components in life support appliances, devices or systems where malfunction of a product can reasonably be expected to result in personal injury. Life support devices or systems are devices or systems that (a) are intended for surgical implant into the body or (b) support or sustain life, and whose failure to perform can be reasonably expected to result in a significant injury to the user. A Purchaser's use or sale of Micrel Products for use in life support appliances, devices or systems is a Purchaser's own risk and Purchaser agrees to fully indemnify Micrel for any damages resulting from such use or sale.

© 2009 Micrel, Incorporated.

X-ON Electronics

Largest Supplier of Electrical and Electronic Components

Click to view similar products for [LED Lighting Drivers](#) category:

Click to view products by [Microchip](#) manufacturer:

Other Similar products are found below :

[LV5235V-MPB-H](#) [MB39C602PNF-G-JNEFE1](#) [FAN5701UMP20X](#) [FAN5702UMP30X](#) [MIC2871YMK-T5](#) [MP1518DJ-LF-P](#) [MP3202DG-LF-P](#) [MP3304BDD-LF-P](#) [MP3306EG-LF-P](#) [MP3398AGY](#) [MP4033GK](#) [AL1676-10BS7-13](#) [AL1676-20AS7-13](#) [MX877RTR](#)
[NCL30085BDR2G](#) [ICL8201](#) [IS31BL3506B-TTLS2-TR](#) [PAM2841GR](#) [A8519KLPTR-T](#) [FAN5701UMP08X](#) [FAN5702UMP20X](#) [AL3157F-7](#)
[AL8807BQMP-13](#) [LV52204MTTBG](#) [MP2488DN-LF](#) [MP24893DQ-LF-P](#) [MP24894GJ-P](#) [MP24895GJ-P](#) [MP3308DL-LF-Z](#) [MP3393EF-LF](#)
[MP3394SGF](#) [MP3802DQ-LF-P](#) [MP4008GS](#) [MP4031GS](#) [MP4032-1GS](#) [MP4034GS](#) [MP46885DN-LF](#) [SLG7NT4082V](#) [SLG7NT4082VTR](#)
[PCA9955BTWQ900J](#) [TLD5095EL](#) [LED6001TR](#) [STP4CMPQTR](#) [BD1604MVV-E2](#) [MC10SX1130DG](#) [MAX16832CASAT](#)
[MAX16814CATP+](#) [NCL30086BDR2G](#) [NCL30088BDR2G](#) [IS31LT3350-V1SDLS2-EB3CH](#)