

## Features

- **Industry Standard Serial ATA (SATA) Host Interface**
    - SATA 1.5 Gb/s or SATA 3.0 Gb/s <sup>1)</sup>
    - ATA/ATAPI-8 compliant
    - Supports 48-bit address feature set
  - **Performance**
    - Sustained sequential data read - Up to 70 MByte/sec\*
    - Sustained sequential data write - Up to 30 MByte/sec\*

\* measured using 128 KByte block size
  - **Power Management**
    - 3.3V and 1.2V power supply
    - Host SATA interface power management
    - Immediate disabling of unused circuitry without host intervention
  - **Power Specifications** <sup>2)</sup>
    - Active mode:
      - 815mW typical (GLS85LS1032A)
      - 565mW typical (GLS85LS1016A)
      - 415mW typical (GLS85LS1008A)
      - 335mW typical (GLS85LS1004A)
    - Idle mode: 210mW typical
    - Standby mode: 190mW typical
  - **Integrated Voltage Detector**
    - Detects supply voltage fluctuations and generates reset during power-up and power-down to prevent inadvertent writes
  - **Supports SMART Commands**
  - **Expanded Data Protection**
    - Added data security through user-selectable protection zones
  - **20-Byte Serial Number**
    - Factory pre-programmed 10-Byte unique ID
    - User-programmable 10-Byte ID
  - **Robust Built-in ECC**
  - **Commercial Temperature Range**
    - 0°C to 70°C
  - **FBGA package**
    - 14.0 mm x 24.0 mm x 1.95 mm, 145-ball, 1.0 mm ball pitch, FZJE
  - **All Devices are RoHS Compliant**
- 1) Current product revision will only support SATA Revision 1.x with host transfer rate of up to 1.5 Gb/s (i.e. SATA 1.5 Gb/s). SATA 3.0 Gb/s refers to SATA Revision 2.x and is planned to be supported by our future product revisions.
- 2) For management of the Sleep Mode, please refer to "SATA NANDrive Application Design Guide."

## Product Description

The GLS85LS1004A / 1008A / 1016A / 1032A Commercial Grade SATA NANDrive™ devices (referred to as "SATA NANDrive" in this datasheet) are high-performance, fully integrated solid state drives. They combine an integrated SATA NAND flash memory controller and 4, 8, 16 or 32 GByte of NAND flash in a multi-chip package. These products are ideal for embedded and portable applications that require smaller form-factor and more reliable data storage.

SATA-interface solid state mass storage technology is widely used in portable and industrial computers, set-top boxes, multi-functional printers, point-of-sales terminals, video and audio recorders, medical instruments and car infotainment systems.

The SATA NANDrive is a single device, solid state drive (SSD) that provides the functionality and compatibility of a complete SATA hard disk drive (HDD) in a 14 mm x 24 mm BGA package for easy, space saving mounting to a system motherboard. These products surpass traditional storage in their small size, security, reliability, ruggedness and low power consumption.

The integrated NAND flash controller with built-in advanced NAND management firmware communicates with the Host through the standard SATA protocol. It does not require any additional or proprietary software such as the Flash File System (FFS) and Memory Technology Driver (MTD).

The SATA NANDrive is pre-programmed with a 10-Byte unique serial ID and has the option of programming an additional 10-Byte serial ID for even greater system security.

The SATA NANDrive's advanced NAND management technology enhances data reliability and security, improves endurance and accurately estimates the remaining lifespan of the NAND flash devices. This innovative technology combines robust NAND controller hardware error correction capabilities with advanced wear-leveling algorithms and bad block management to significantly extend the life of the product.

The SATA NANDrive devices are offered in a 145-ball BGA, 1 mm ball pitch package. Refer to Figure 3-1 for the pin assignments.

## 1.0 GENERAL DESCRIPTION

Each SATA NANDrive contains an integrated SATA NAND flash memory controller and up to eight discrete NAND flash die in a BGA package. Refer to Figure 2-1 for the SATA NANDrive block diagram.

### 1.1 Optimized SATA NANDrive

The heart of the SATA NANDrive is the SATA NAND flash memory controller which translates standard SATA signals into flash media data and control signals. The following components contribute to the SATA NANDrive's operation.

#### 1.1.1 Microcontroller Unit (MCU)

The MCU translates SATA commands into data and control signals required for flash media operation.

#### 1.1.2 Internal Direct Memory Access (DMA)

The SATA NANDrive uses internal DMA allowing instant data transfer from/to buffer to/from flash media. This implementation eliminates microcontroller overhead associated with the traditional, firmware-based approach, thereby increasing the data transfer rate.

#### 1.1.3 Power Management Unit (PMU)

The PMU controls the power consumption of the SATA NANDrive. The PMU dramatically reduces the power consumption of the SATA NANDrive by putting the part of the circuitry that is not in operation into sleep mode.<sup>3)</sup>

The Flash File System handles inadvertent power interrupts and has auto-recovery capability to ensure SATA NANDrive firmware integrity. For regular power management, the Host must send an IDLE\_IMMEDIATE command and wait for command ready before powering down the SATA NANDrive.

<sup>3)</sup> For management of the Sleep Mode, please refer to "SATA NANDrive Application Design Guide."

#### 1.1.4 Embedded Flash File System

The embedded flash file system is an integral part of the SATA NANDrive. It contains MCU firmware that performs the following tasks:

1. Translates host side signals into flash media writes and reads
2. Provides flash media wear leveling to spread the flash writes across all memory address space to increase the longevity of flash media
3. Keeps track of data file structures
4. Manages system security for the selected protection zones

#### 1.1.5 Error Correction Code (ECC)

High performance is achieved through optimized hardware error detection and correction.

#### 1.1.6 Serial Communication Interface (SCI)

The Serial Communication Interface (SCI) is designed for manufacturing error reporting. During the design process, always provide access to the SCI port in the PCB design to aid in design validation.

#### 1.1.7 Multi-tasking Interface

The multi-tasking interface enables fast, sustained write performance by allowing concurrent Read, Program and Erase operations to multiple flash media and NAND flash die.

## 1.2 NAND Flash

The SATA NANDrive family utilizes standard NAND flash for data storage. Because the high temperature in a surface-mount soldering reflow process can alter the content on NAND flash, do not program the SATA NANDrive before the reflow process.

## 1.3 Advanced NAND Management

Advanced NAND management technology balances the wear on erased blocks with wear-leveling algorithms. When the Host updates data, higher priority is given to the less frequently written erase blocks, thereby evenly distributing host writes within the SATA NANDrive.

Advanced NAND management technology enhances SATA NANDrive's security with password protection and four independent protection zones that can be set to Read-only or Hidden.

## 2.0 FUNCTIONAL BLOCKS

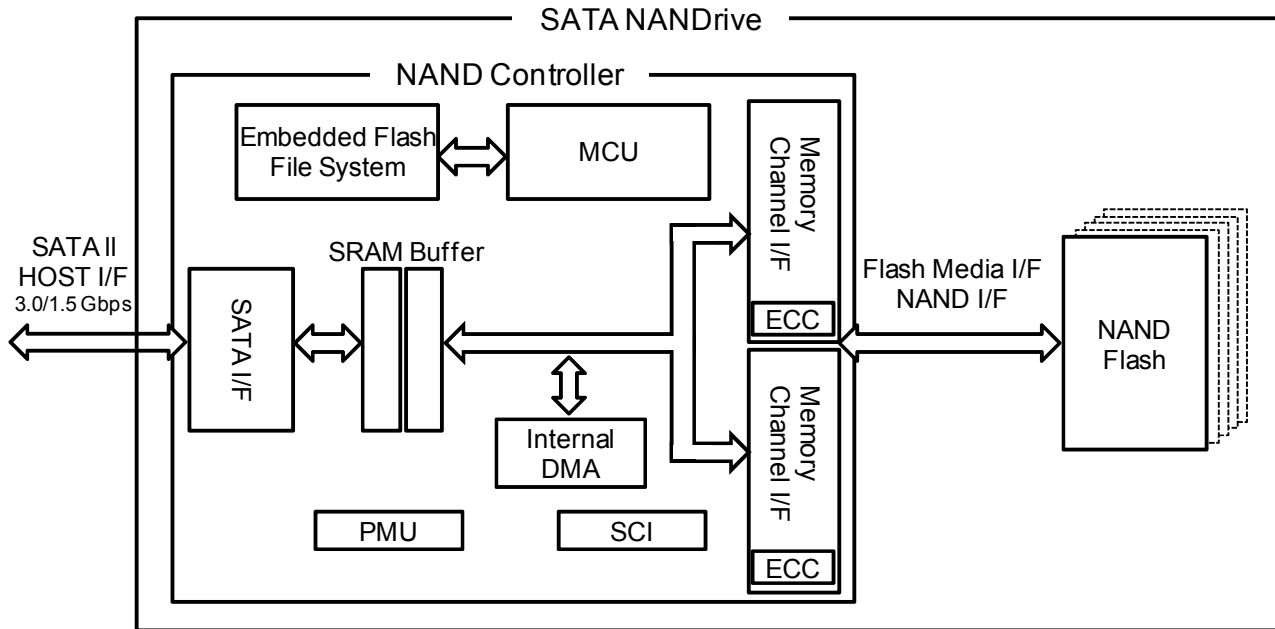

Figure 2-1: SATA NANDrive Block Diagram

## 3.0 PIN ASSIGNMENTS

The signal/pin assignments are listed in Table 3-1. Low active signals have a “#” suffix. Pin types are Input, Output or Input/Output.

TOP VIEW (balls facing down)

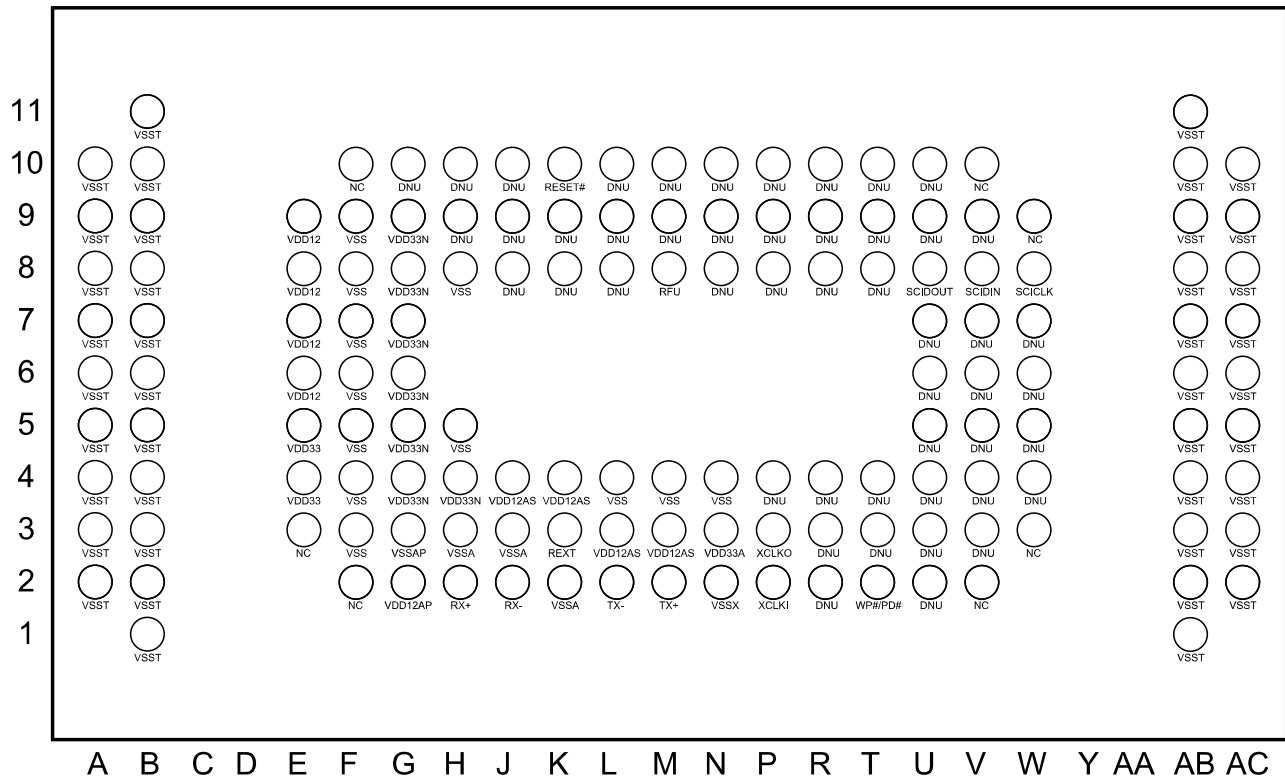

Figure 3-1: Pin Assignments for 145-Ball BGA

Table 3-1: Pin Assignments

Symbol	Ball No.	Ball Type	IO Type	Name and Functions
<b>Host Side Interface</b>				
RX+	H2	I	I3	Analog Differential Input (+)
RX-	J2	I	I3	Analog Differential Input (-)
TX+	M2	O	O3	Analog Differential Output (+)
TX-	L2	O	O3	Analog Differential Output(-)
<b>Serial Communication Interface (SCI)</b>				
SCIDIN	V8	I	I2U	SCI port data input
SCIDOUT	U8	O	O1	SCI port data output. No external pull-up or pull-down resistor should connect to this signal.
SCICLK	W8	I	I2U	SCI port clock
<b>Miscellaneous</b>				
RFU	M8			Reserved for Future Use
Rext	K3	I	I3	External Resistor, 1Kohms (1%) connected to GND
RESET#	K10	I	I2U	This input is the active low hardware reset from host.
WP#/PD#	T2 <sup>4)</sup>	I	I2U	The WP#/PD# can be used for either the Write Protect mode or Power Down mode, but only one mode is active at any time.
XCLKI	P2	O	XI	External clock source input for main clock; 25MHz crystal, need external 20pf capacitor to ground
XCLKO	P3	O	XO	External clock source output for main clock; 25MHz crystal, need external 20pf capacitor to ground
NC	E3, F2, F10, V2, V10, W3, W9			No connect
DNU	G10, H9, H10, J8, J9, J10, K8, K9, L8, L9, L10, M9, M10, N8, N9, N10, P4, P8, P9, P10, R2, R3, R4, R8, R9, R10, T3, T4, T8, T9, T10, U2, U3, U4, U5, U6, U7, U9, U10, V3, V4, V5, V6, V7, V9, W4, W5, W6, W7			Do Not Use. All these pins should not be connected.
<b>Power and Ground</b>				
VDD33	E4, E5	Digital PWR		Supply voltage 3.3V
VDD33A	N3	Digital PWR		
VDD33N	G4, G5, G6, G7, G8, G9, H4	Digital PWR		
VDD12	E6, E7, E8, E9	Digital PWR		Supply voltage 1.2V
VDD12AS	J4, K4, L3, M3	Analog PWR		Analog supply voltage 1.2V (200mA max. total for both 1.2V analog power rails, VDD12AS and VDD12AP)
VDD12AP	G2	Analog PWR		
VSS	F3, F4, F5, F6, F7, F8, F9, H5, H8, L4, M4, N4	Digital GND		Digital ground
VSSX	N2	Digital GND		Digital ground
VSST	A2, A3, A4, A5, A6, A7, A8, A9, A10, B1, B2, B3, B4, B5, B6, B7, B8, B9, B10, B11, AB1, AB2, AB3, AB4, AB5, AB6, AB7, AB8, AB9, AB10, AB11, AC2, AC3, AC4, AC5, AC6, AC7, AC8, AC9, AC10	GND		Connected to PCB ground plane for thermal dissipation. Not connected to any internal signal.
VSSA	H3, J3, K2	Analog GND		Analog ground
VSSAP	G3	Analog GND		Analog ground

Table 3-2: I/O Type

I/O Type	Description
I3	Analog Input
O3	Analog Output
I2D	Input with Pull-down
I2U	Input with Pull-up
O1	Output
XI	Crystal Clock Input
XO	Crystal Clock Output

- 4) The command to configure the T2 pin in either PD# or WP# is prepared by the vendor-unique command. Please ask your Greenliant contact for details on the SMART command specification.

**4.0 Product Ordering Information**

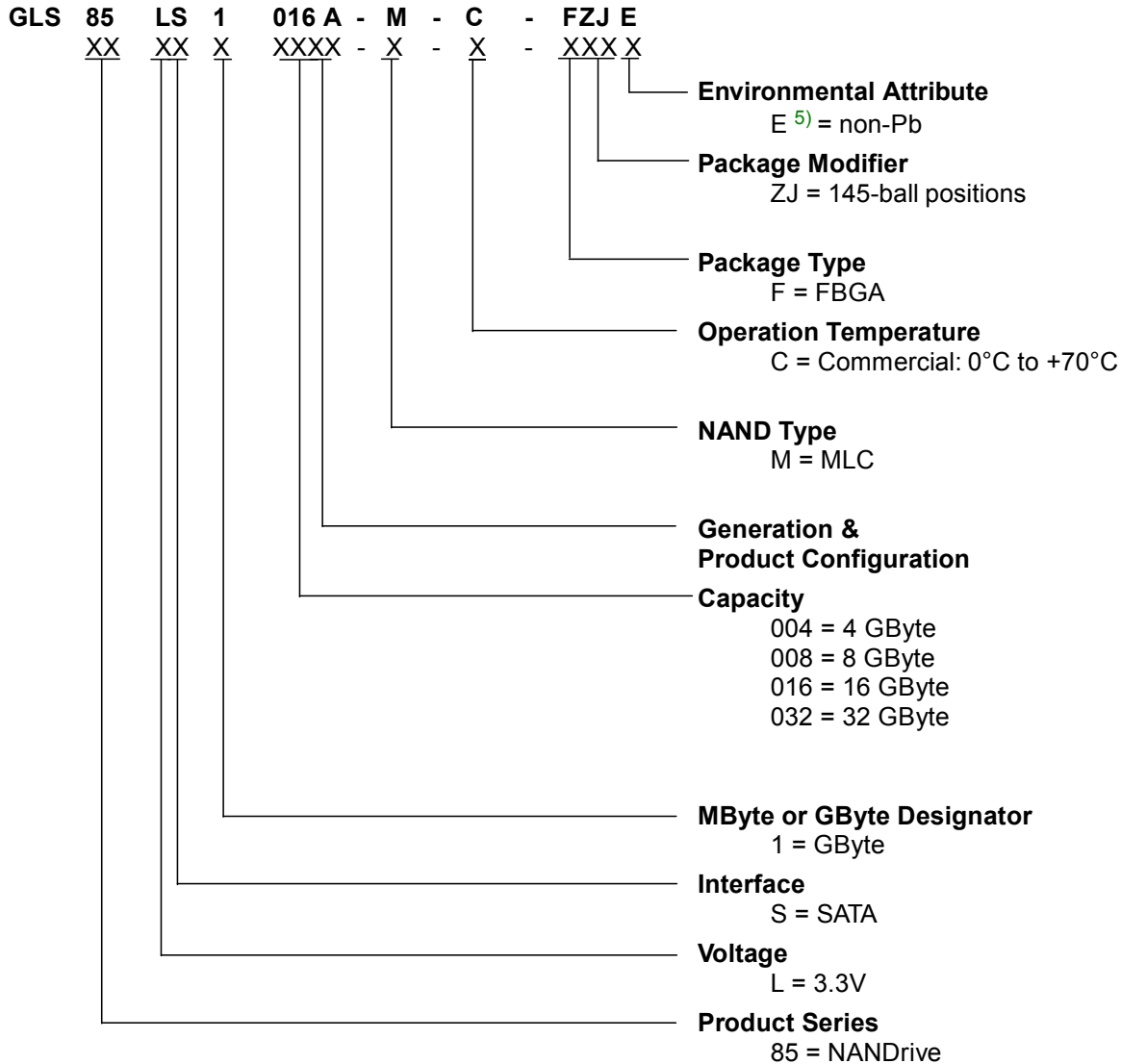

<sup>5)</sup> Environmental suffix “E” denotes non-Pb solder.  
 Greenliant non-Pb solder devices are “RoHS Compliant.”

**Valid Combinations <sup>6)</sup>**

**SATA NANDrive Product**

**GLS85LS1004A-M-C-FZJE, GLS85LS1008A-M-C-FZJE**  
**GLS85LS1016A-M-C-FZJE, GLS85LS1032A-M-C-FZJE**

**SATA NANDrive Evaluation Board, (1S: SATA Interface EVB, K: Kit)**

**GLS85LS1004A-M-C-1S-K, GLS85LS1008A-M-C-1S-K**  
**GLS85LS1016A-M-C-1S-K, GLS85LS1032A-M-C-1S-K**

**SATA NANDrive mini-SATA Evaluation Board, (1mS: mini-SATA Interface EVB, K: Kit)**

**GLS85LS1004A-M-C-1mS-K, GLS85LS1008A-M-C-1mS-K**  
**GLS85LS1016A-M-C-1mS-K, GLS85LS1032A-M-C-1mS-K**

<sup>6)</sup> Valid product combinations are those that are in the mass production or will be in the mass production. Consult your Greenliant sales representative to confirm availability of the valid product combinations and to determine availability of new product combinations.

### 4.1 Packaging Diagram

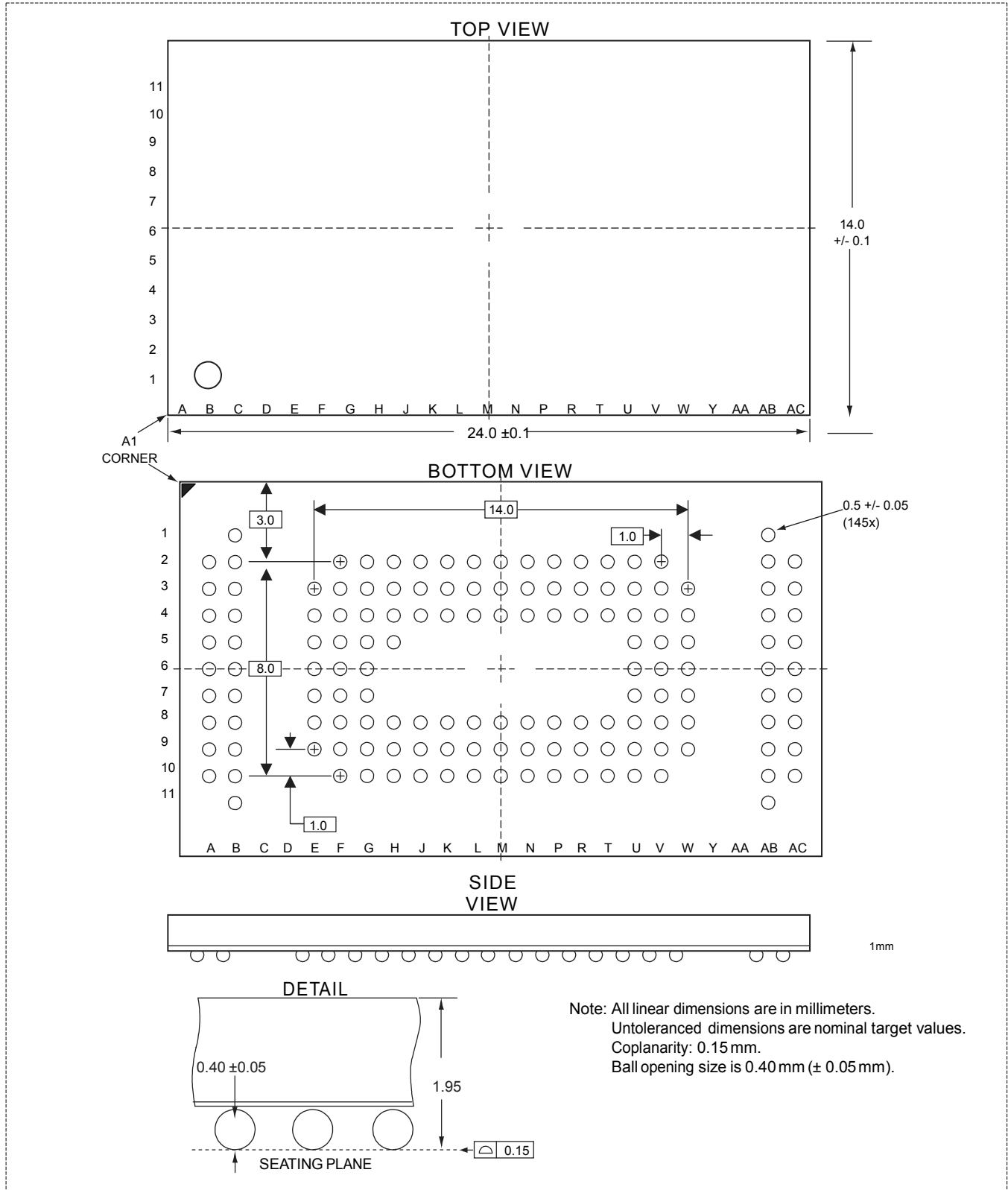

Figure 4-1: SATA NANDrive 145-Ball, Ball Grid Array (BGA) Greenliant Package Code: FZJ

**Revision History**

<b>Revision</b>	<b>Description</b>	<b>Date</b>
01.000	Initial release of Fact Sheet for GLS85LS1004A / 1008A / 1016A / 1032A	September 13, 2011

© 2011 Greenliant Systems. All rights reserved.

Greenliant, the Greenliant Logo and NANDrive are trademarks of Greenliant Systems. All other trademarks and registered trademarks are the property of their respective owners.

Specifications are subject to change without notice. Memory sizes denote raw storage capacity; actual usable capacity may be less.

Greenliant makes no warranty for the use of its products other than those expressly contained in the Greenliant Terms and Conditions of Sale.

[www.greenliant.com](http://www.greenliant.com)

## X-ON Electronics

Largest Supplier of Electrical and Electronic Components

*Click to view similar products for [Solid State Drives - SSD category](#):*

*Click to view products by [Greenliant manufacturer](#):*

Other Similar products are found below :

[MTFDDAK256MAZ-1AE12ABYY](#) [SSDSC2CT120A3K5](#) [MTFDDAC512MAM-1K1](#) [SSDPEKKF010T7X1](#) [ATCA7360-MMOD-SATA2](#)  
[SQF-S25S2-8G-S9C](#) [SQF-SLMM4-128G-S9C](#) [96FD25-S128-TR7](#) [SQF-SMSS4-32G-S8E](#) [96FD25-S512-TR7](#) [SQF-SLMM4-16G-S9E](#) [SQF-](#)  
[SDMS4-16G-J6C](#) [SQF-S25S4-16G-S9C](#) [96FD80-N128-LIS](#) [ASD25-MLC064G-CT-160-1](#) [SQF-SMSU4-32G-S9E](#) [SQF-SMSU4-256G-SBE](#)  
[SQF-SMSM4-32G-S9E](#) [SQF-SMSM4-16G-S9C](#) [SQF-SMSM2-8G-S9E](#) [SQF-SHMS2-16G-S9C](#) [96ND1T-ST-SG7E](#) [SQF-SMSM4-128G-SBE](#)  
[SQF-S25U4-128G-SBC](#) [96FD-M032-TR71](#) [SQF-SHMM1-32G-SBC](#) [SSDSC2BX800G401940785](#) [SSDSCKJB150G701](#) [SDUFD33-016G](#)  
[SD7SN6S-128G-1122](#) [AF512UDI-FLU003](#) [SDLF1DM-800G-1HA1](#) [SM619GED-CDZ SPA31L](#) [SD9SN8W-128G-1122](#) [SD9SN8W-128G](#)  
[SDINBDG4-32G-XI1](#) [SSDSC2KR120H6XN](#) [SDSDQAD-128G](#) [SM668GXB-ACS O1118](#) [SDSDAA-016G](#) [SDLF1CRM-016T-1HA1](#)  
[0T00327](#) [MTFDDAA240MBB-2AE1ZABYY](#) [SSDSC2BX200G401940779](#) [SQF-S25V4-240G-SCC](#) [SQF-SDMM2-256G-S9E](#) [SQF-SHMM2-](#)  
[64G-SBE](#) [APSDM001G12AN-PT](#) [96FD25-ST256G-M13](#) [SQF-SM8V4-240G-SCC](#)