



Quam

SSB-2, SSB-3, SSB-4 SSB-6, SSB-7, SSB-9 SSC-1

Loudspeaker Mounting Devices

0402 - LOUDSPEAKER MOUNTING DEVICES

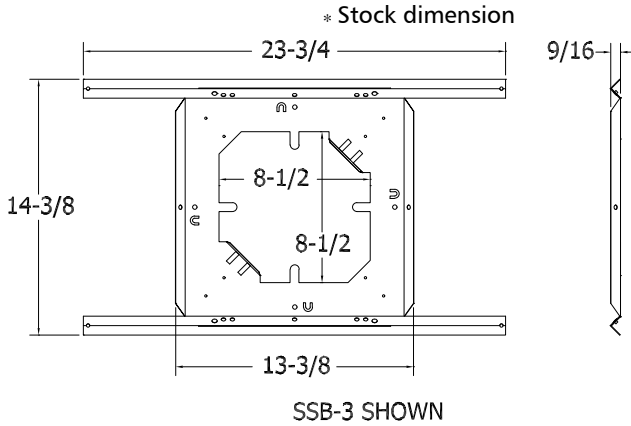

SSB-3 SHOWN

GENERAL DESCRIPTION

The Quam SSB-(2, 3, 4, 6, 7, 9) is a rust resistant steel, load bearing support for a loudspeaker assembly.

The Quam SSC-1 is a pair of rust resistant steel, load bearing mounting channels.

INTENDED USE

SSB-(2, 3, 4, 6, 9): Parallel to floor plane in a suspended ceiling structure; maximum span of 24" in one dimension; indoor environment. Refer to schedule on reverse for frame compatibility.

SSB-7: 8" frame loudspeaker, new gypsum board construction; indoor environment.

SSC-1: Gypsum board or drop tile ceiling applications; indoor environment.

* 23-3/4" Stock dimension, lengths up to 48" available on SSB-2, 3, 4, 6, 9 and SSC-1 as a special order, please contact Factory for delivery and pricing

RECOMMENDED ADDITIONAL QUAM COMPONENTS

Refer to schedule on Page 2 for frame compatibility

MECHANICAL DIMENSIONS

Refer to Page 2

Recommended construction sequences, installation instructions and A&E Specifications are available in various formats on the Quam Architects' and Engineers' Resources CD or on the web at: www.quamspeakers.com

BACK BOXES / MOUNTING DEVICES

04

Quam-Nichols Company

234 East Marquette Road, Chicago, IL 60637
Phone: (800) NEED NOW Fax: (888) NEED NOW
(800) 633 - 3669 (888) 633 - 3669
E-Mail: neednow@qnc.com www.quamspeakers.com





Quam

0402 - LOUDSPEAKER MOUNTING DEVICES

BAFFLES	SSB-2	SSB-3	SSB-4	SSB-6	SSB-7	SSB-9	SSC-1
BR4W			✓				✓
BR4WS			✓				✓
BR8-2WS				✓			
BR8A	✓	✓			✓		✓
BR8VP	✓	✓			✓		
BR8W	✓	✓			✓		✓
BR8WS	✓	✓			✓		✓
BS8VP	✓	✓					
BS8W	✓	✓					
BS8WS	✓	✓					
TBR8W		✓					
TBR8WS		✓					
QMount™						✓	

NOTE: With the exception of QMount™ (SSB-9), all SSB assemblies can use ERD-8 or ERDU back boxes

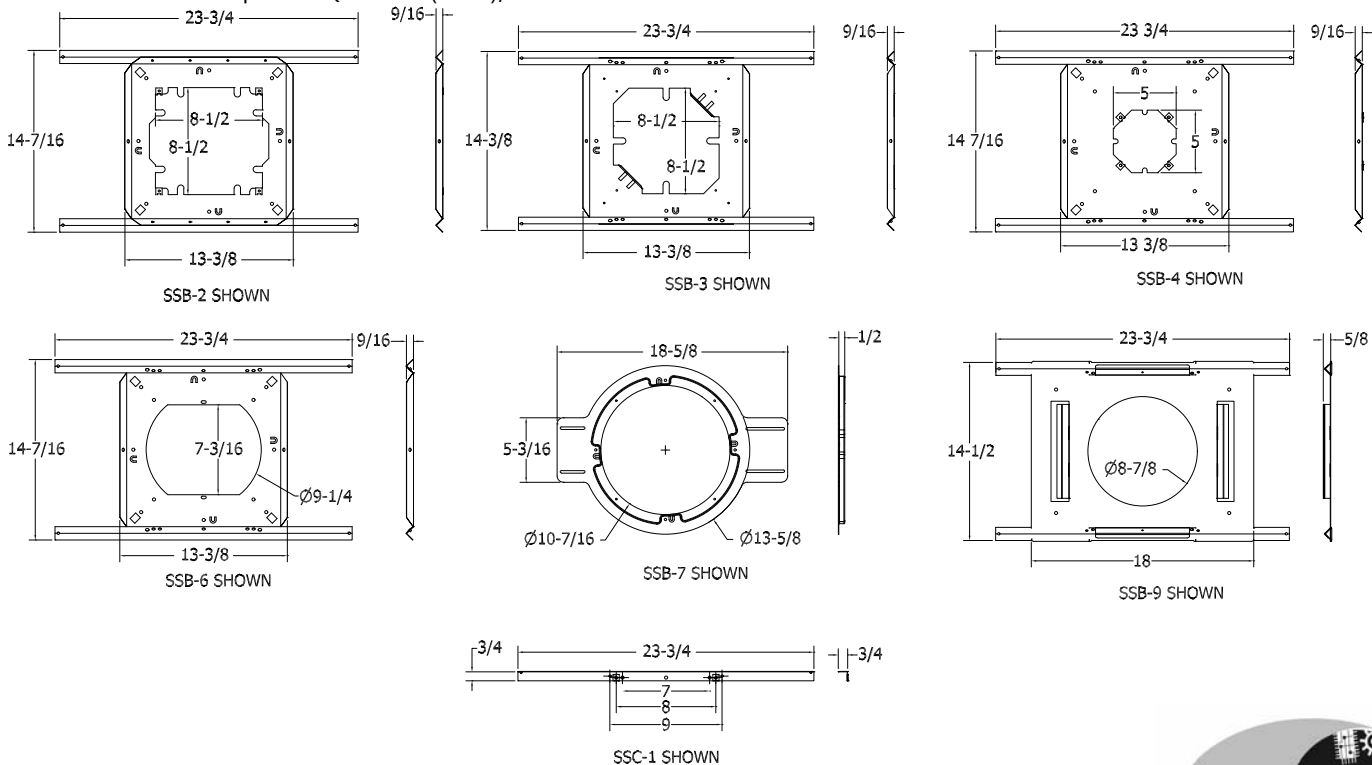

04 BACK BOXES / MOUNTING DEVICES

Quam-Nichols Company

234 East Marquette Road, Chicago, IL 60637
 Phone: (800) NEED NOW Fax: (888) NEED NOW
 (800) 633 - 3669 (888) 633 - 3669
 E-Mail: neednow@qnc.com www.quamspeakers.com



X-ON Electronics

Largest Supplier of Electrical and Electronic Components

Click to view similar products for [quam nichols](#) manufacturer:

Other Similar products are found below :

[30C25Z450T](#) [8C5Z45](#) [8C10FECOB](#) [ERD-8](#) [4C3PA](#)