

SSA-EBM Series Emergency Stop Push Buttons with OTBVP6

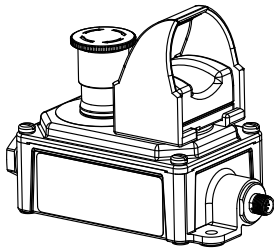

Push-to-Stop, Twist-to-Release Electro-Mechanical Push Buttons

Features



- Push-to-stop, twist-to-release operation per IEC60947-5-5
- Latching design complies with ISO 13850; direct (positive) opening operation per IEC 60947-5-1
- OTBVP6 provides normally open PNP output for a variety of functions
- 8-pin M12/Euro-style Quick Disconnect
- Yellow plastic enclosure
- Rugged design; easy installation with no assembly or individual wiring required

Models SSA-EB... series are "mushroom-style" electro-mechanical emergency stop push buttons. When the button is armed, the switch's safety contacts (N.C.) are closed and its monitoring contacts (N.O.), if present, are open. When the button is pushed, the switch's safety contacts open and the monitoring contacts close. The contacts remain in this condition until the push button is manually rearmed by twisting clockwise the red push button actuator.

The OTBVP6 is intended as a general-purpose initiator, and by itself is not a safety device. The output is ON when an object (for example, an individual's finger) is placed in the sensing area. A field cover is included to minimize the possibility of unintended or inadvertent activation. If this cover is missing or has become lost or damaged, contact Banner for a no-charge replacement. See the OTB datasheet p/n 28436, available at <http://www.bannerengineering.com>, for additional information.

Models

Model	E-Stop Contacts	OTB Contacts
SSA-EBM-11EB1Q80TBB	1 N.C. (positive opening) / 1 N.O.	1 N.O. PNP
SSA-EBM-02EB1Q80TBB	2 N.C. (positive opening)	1 N.O. PNP
SSA-EBM-12EB1Q80TBB	2 N.C. (positive opening) / 1 N.O. PNP (switches supplied +24V dc)	1 N.O. PNP

Important... Read this before proceeding!

The user is responsible for satisfying all local, state, and national laws, rules, codes, and regulations relating to the use of this product and its application. Banner Engineering Corp. has made every effort to provide complete application, installation, operation, and maintenance instructions. Please direct any questions regarding the use or installation of this product to the factory applications department at the telephone numbers or address found at <http://www.bannerengineering.com>.

The user is responsible for making sure that all machine operators, maintenance personnel, electricians, and supervisors are thoroughly familiar with and understand all instructions regarding the installation, maintenance, and use of this product, and with the machinery it controls. The user and any personnel involved with the installation and use of this product must be thoroughly familiar with all applicable standards, some of which are listed within the specifications. Banner Engineering Corp. makes no claim regarding a specific recommendation of any organization, the accuracy or effectiveness of any information provided, or the appropriateness of the provided information for a specific application.



WARNING: Not a Safeguarding Device

An Emergency Stop Device is not considered a safeguarding device because it requires an overt action by an individual to stop machine motion or hazards.

(A safeguarding device limits or eliminates an individual's exposure to a hazard *without action by the individual or others.*) Because an individual must actuate the device for it to function, these devices do not fit the definition of a safeguarding device and cannot be substituted for required safeguarding. Refer to the relevant standards to determine those requirements.

Emergency Stop Considerations

ANSI NFPA 79, ANSI B11.19, IEC/EN 60204-1, and ISO 13850 specify emergency stop requirements, including the following:

- Emergency-stop push buttons shall be located at each operator control station and at other operating stations where emergency shutdown is required.
- Stop and emergency-stop push buttons shall be continuously operable and readily accessible from all control and operating stations where located. Do not mute or bypass E-stop buttons.
- Actuators of emergency-stop devices shall be colored red. The background immediately around the device actuator shall be colored yellow (where possible). The actuator of a push-button-operated device shall be of the palm or mushroom-head type.
- The emergency-stop actuator shall be a self-latching type.



WARNING: Emergency Stop Functions

Do not mute or bypass any Emergency Stop device. ANSI B11.19, ANSI NFPA79 and IEC/EN 60204-1 require that **the Emergency Stop function remain active at all times.**



WARNING: Multiple Switching Devices

Whenever two or more devices are connected to the same safety module (controller):

- **Contacts of the corresponding pole of each switch must be connected together in series. Never connect the contacts of multiple switches in parallel.** Such a parallel connection defeats the switch contact monitoring ability of the Module and creates an unsafe condition which could result in serious injury or death.
- **Each device must be individually actuated (engaged), then released (or re-armed) and the safety module reset.** This allows the module to check each switch and its wiring to detect faults.

This check must be performed during the prescribed checkouts. **Failure to test each device individually in this manner could result in undetected faults and create an unsafe condition which could result in serious injury or death.**

Installation and Maintenance

The device must not be affected by environmental conditions. **Install the device so that operation is not impeded, but should be protected against inadvertent operation** (for example, accidental actuation by being bumped or leaned against). All hardware is user-supplied.

Electrical installation must be made by qualified personnel and must comply with NEC (National Electrical Code), ANSI/NFPA 79 or IEC/EN 60204-1, and all applicable local standards. It is not possible to give exact wiring instructions for a device that interfaces to a multitude of machine control configurations. The following is general in nature; it is recommended to perform a risk assessment to ensure appropriate application, interfacing/hookup, and risk reduction (see ISO 12100 or ANSI B11.0).

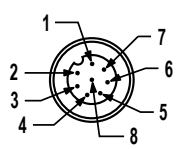
Pin	Color	Function			Description/Contact	Pinout
		SSA-EBM-11EB1Q8OTBB	SSA-EBM-02EB1Q8OTBB	SSA-EBM-12EB1Q8OTBB		
1	White	OTB N.O.	OTB N.O.	OTB N.O.	OTB N.O. (PNP)	 <p>Male Color corresponds to European M12 Specification</p>
2	Brown	+24V dc	+24V dc	+24V dc	OTB supply, E-Stop N.O. (a)	
3	Green	not used	not used	E-Stop N.O. (Aux)	E-Stop N.O. (b) Output switches +24V dc	
4	Yellow	E-Stop N.O.	E-Stop N.C.	E-Stop N.C.	CH2(a)	
5	Gray	E-Stop N.O.	E-Stop N.C.	E-Stop N.C.	CH2(b)	

Pin	Color	Function			Description/Contact	Pinout
		SSA-EBM-11EB1Q8OTBB	SSA-EBM-02EB1Q8OTBB	SSA-EBM-12EB1Q8OTBB		
6	Pink	E-Stop N.C.	E-Stop N.C.	E-Stop N.C.	CH1(a)	
7	Blue	0V dc	0V dc	0V dc	OTB common	
8	Red	E-Stop N.C.	E-Stop N.C.	E-Stop N.C.	CH1(b)	



WARNING: Shock Hazard and Hazardous Energy

Always disconnect power from the safety system (for example, device, module, interfacing, etc.) and the machine being controlled before making any connections or replacing any component.

Electrical installation and wiring must be made by Qualified Personnel and must comply with the relevant electrical standards and wiring codes, such as the NEC (National Electrical Code), ANSI NFPA79, or IEC 60204-1, and all applicable local standards and codes.

Lockout/tagout procedures may be required. Refer to OSHA 29CFR1910.147, ANSI Z244-1, or the appropriate standard for controlling hazardous energy.

Specifications

Construction

Housing: Base: PBT; Cover: Polycarbonate; Mounting: 1/4-inch or M7, Max. Tightening Torque: 0.56 N·m (5 in·lbf)

E-Stop Button: Plastic: Polycarbonate / Polyamide;
Metal: Aluminum and zinc alloy

OTBVP6: See OTBVP6 specifications

Operating Conditions

Temperature: -20° to +50° C (-4° to +122° F)

Humidity: 45% to 85% RH (no condensation)

Environmental Rating

IP50 (IEC60526)

Output Configuration

See [Installation and Maintenance](#) on page 2

Mechanical Life

E-Stop Button: 300,000 operations

Contacts: 1,000,000 operations

Electrical Life

E-Stop Contacts: 1,000,000 operations

Supply Voltage

10 to 30 V dc

OTBVP6: 25 mA, exclusive of load (see OTBVP6 specifications)

Electrical Rating

2A at 60V ac/75V dc maximum

Rated Insulation Voltage (Ui)

60V ac / 75V dc

Rated Current (Ith)

2A

OTBVP6 Touch Button Specifications

Output Configuration: Normally Open PNP sourcing output

Output Rating: 150 mA maximum load

Ambient Light Immunity: 120,000 lux (direct sunlight)

EMI/RFI Immunity: Highly resistant to both single and mixed EMI and RFI noise sources

Indicator LEDs: Two indicator LEDs: Power ON; Output ON

Construction:

Black polysulfone upper housing and fiber-reinforced VALOX® base. Electronics fully epoxyen-capsulated. Sealed, non-metallic enclosure.

Field cover of polycarbonate-PET polyester.

Environmental Considerations: Prolonged exposure to direct outdoor sunlight will cause embrittlement of the polysulfone housing. Window glass provides protection from sunlight. Contact the Banner Engineering regarding outdoor applications.

Clean periodically using mild soap solution and a soft cloth. Avoid strong alkaline materials.

Certifications

E-Stop Button:  

OTBVP6:   

E-Stop Design Standards

Compliant with EN/IEC 60497-1 / -5-1, ISO 13850, ANSI B11.19, ANSI NFPA79, IEC 60204-1

Rated Operating Current and Voltage (Ue)

		24V	48V	60VAC/ 75VDC
AC 50/60 Hz	Inductive Load (AC-15)	2A	2A	2A
DC	Inductive Load (DC-13)	2A	1.5A	0.55A

Checkout

At machine set up, a *Designated Person*¹ should test each emergency stop push button for proper machine shutdown response. A *Designated Person* should check the emergency stop buttons for proper operation, physical damage, button looseness, and excessive environmental contamination. This should take place on a periodic schedule determined by the user, based on the severity of the operating environment and the frequency of switch actuations. Adjust, repair, or replace components as needed. If inspection reveals contamination on the switch, thoroughly clean the switch and eliminate the cause of the contamination. Replace the switch and/or appropriate components when any parts or assemblies are damaged, broken, deformed, or badly worn; or if the electrical/mechanical specifications (for the environment and operating conditions) have been exceeded. **Always test the control system for proper functioning** under machine control conditions after performing maintenance, replacing the emergency stop device, or replacing any component of the device.

Dimensions

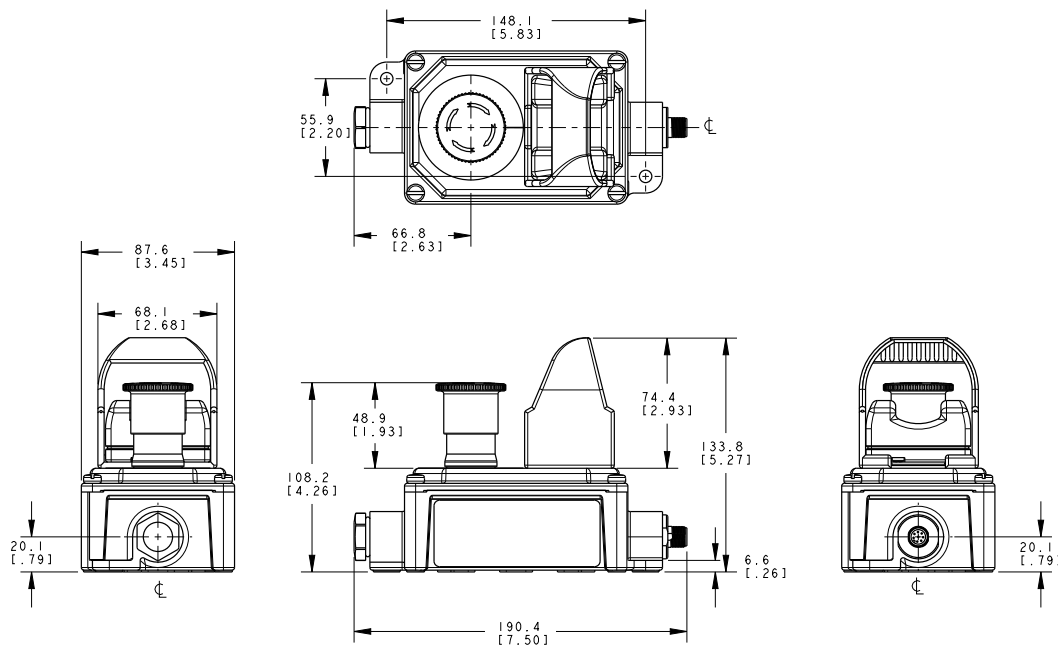

U.S. Application Standards

ANSI B11.0 Safety of Machinery; General Requirements and Risk Assessment

ANSI B11.19 Performance Criteria for Safeguarding

¹ A *Designated Person* is identified in writing by the employer as being appropriately trained to perform a specified checkout procedure. A *Qualified Person* possesses a recognized degree or certificate or has extensive knowledge, training, and experience to solve problems relating to the emergency stop installation.

ANSI NFPA 79 Electrical Standard for Industrial Machinery

International/European Standards

ISO 12100 Safety of Machinery – General Principles for Design — Risk Assessment and Risk Reduction

ISO 13850 (EN 418) Emergency Stop Devices, Functional Aspects – Principles for Design

IEC 62061 Functional Safety of Safety-Related Electrical, Electronic and Programmable Control Systems

ISO 13849-1 (EN 954-1) Safety-Related Parts of Control Systems

IEC 60204-1 Electrical Equipment of Machines Part 1: General Requirements

IEC 60947-1 Low Voltage Switchgear – General Rules

IEC 60947-5-1 Low Voltage Switchgear – Electromechanical Control Circuit Devices

IEC 60947-5-5 Low Voltage Switchgear – Electrical Emergency Stop Device with Mechanical Latching Function

Banner Engineering Corp Limited Warranty

Banner Engineering Corp. warrants its products to be free from defects in material and workmanship for one year following the date of shipment. Banner Engineering Corp. will repair or replace, free of charge, any product of its manufacture which, at the time it is returned to the factory, is found to have been defective during the warranty period. This warranty does not cover damage or liability for misuse, abuse, or the improper application or installation of the Banner product.

THIS LIMITED WARRANTY IS EXCLUSIVE AND IN LIEU OF ALL OTHER WARRANTIES WHETHER EXPRESS OR IMPLIED (INCLUDING, WITHOUT LIMITATION, ANY WARRANTY OF MERCHANTABILITY OR FITNESS FOR A PARTICULAR PURPOSE), AND WHETHER ARISING UNDER COURSE OF PERFORMANCE, COURSE OF DEALING OR TRADE USAGE.

This Warranty is exclusive and limited to repair or, at the discretion of Banner Engineering Corp., replacement. **IN NO EVENT SHALL BANNER ENGINEERING CORP. BE LIABLE TO BUYER OR ANY OTHER PERSON OR ENTITY FOR ANY EXTRA COSTS, EXPENSES, LOSSES, LOSS OF PROFITS, OR ANY INCIDENTAL, CONSEQUENTIAL OR SPECIAL DAMAGES RESULTING FROM ANY PRODUCT DEFECT OR FROM THE USE OR INABILITY TO USE THE PRODUCT, WHETHER ARISING IN CONTRACT OR WARRANTY, STATUTE, TORT, STRICT LIABILITY, NEGLIGENCE, OR OTHERWISE.**

Banner Engineering Corp. reserves the right to change, modify or improve the design of the product without assuming any obligations or liabilities relating to any product previously manufactured by Banner Engineering Corp.

X-ON Electronics

Largest Supplier of Electrical and Electronic Components

Click to view similar products for [banner manufacturer](#):

Other Similar products are found below :

[Q45VR2FPQ](#) [BTA23S](#) [RS-11](#) [L16F](#) [2LM3](#) [2PBA](#) [LM8-1](#) [LMT](#) [SM312CV](#) [SM31RQD](#) [LS4ELQ](#) [FX1](#) [Q45BB6LLQ](#) [QM42VP6AFV150Q](#)
[D12SP6FP](#) [MBCC-412](#) [BA23S](#) [BT21S](#) [BTA13S](#) [LM4-2](#) [Q25SP6LPQ](#) [ES-FA-6G](#) [T183E](#) [SLSP30-600Q88](#) [SLSP30-1200Q88](#) [OPBA5](#)
[PBAT](#) [SBLV1](#) [SMA91EQD](#) [SMA91E](#) [SMA912LVQD](#) [SMA912DQD](#) [SM2A312CVQD](#) [SM2A912LVQD](#) [SM31RL](#) [TL70RAQ](#) [TL70RQ](#)
[K50LGRYPQ](#) [LEDRR70X70-78587](#) [BRT-THG-4X4-5](#) [T18-2VNDL-Q8](#) [SLLP14-1190P88](#) [SME312DQD](#) [SM312CUQD](#) [BR-2](#) [BR23P](#)
[SM2A312FPQD](#) [SM2A312LVQD](#) [SM31EQD](#) [D12EP6FP](#)