

Material 物料
Housing: High-Temp Plastic.
LCP, UL 94V-0, White
LCP, UL 94V-0, Black

Actuator: LCP, UL 94V-0, Black
Contact: Phosphor Bronze 磷青銅
Finish (a) Contact Plating: see ordering grid
(b) Underplating: Nickel-plated all over
Fitting Nail: Brass, tin plated

Mechanical & Environmental 机械 & 环境
Durability: 20 Cycles
Operating Temperature: -25°C to +85°C
Solder Profile: Peak Temp 260°C (+0/-5°C) max. (5 seconds)

Solder Profile: Peak Temp 260°C (+0/-5°C) max. (5 seconds)

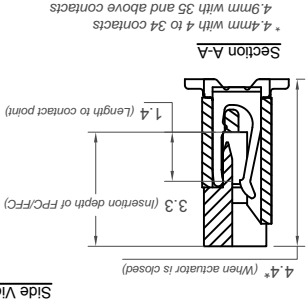
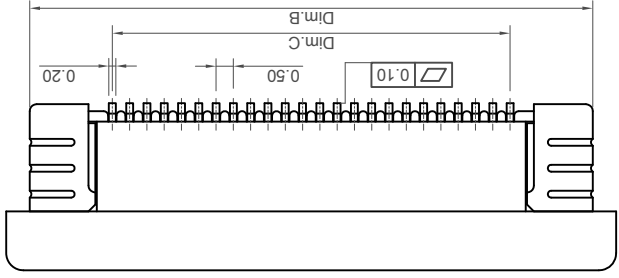

Side Views

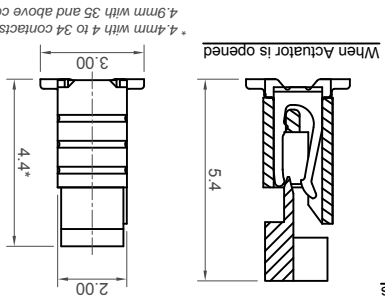

* 4.4mm with 35 and above contacts

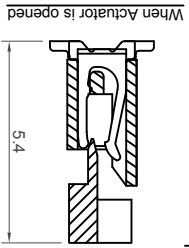

When Actuator is opened

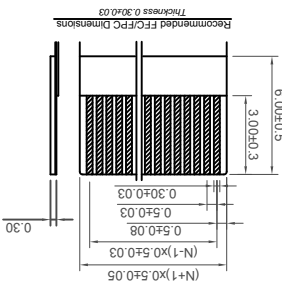

Recommended FFC/FPC Dimensions
Thickness 0.30±0.03

0.30

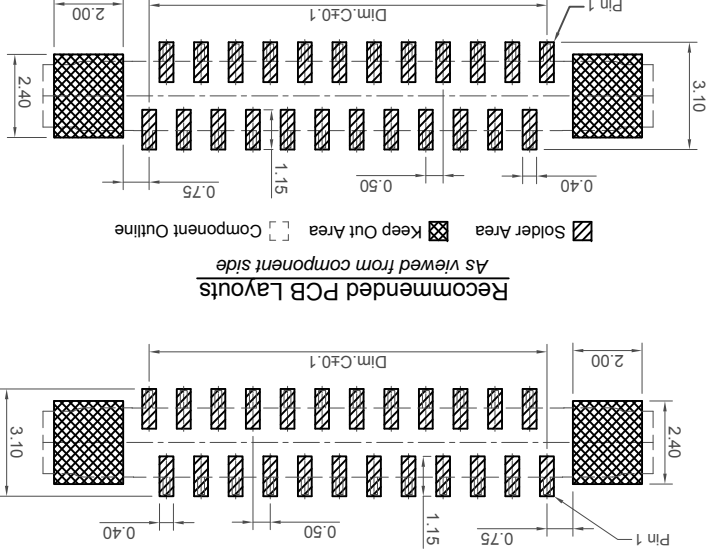
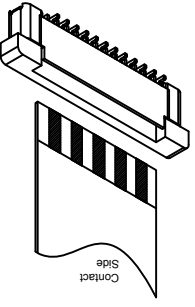

Recommended PCB Layouts
As viewed from component side

▨ Solder Area ▩ Keep Out Area □ Component Outline

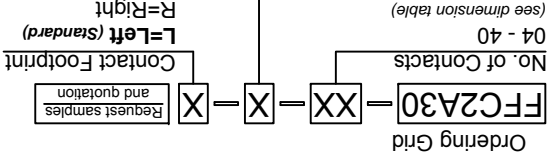

04 - 40
(see dimension table)

Contact Footprint
L=Left (Standard)
R=Right
Contact Plating
T=Tin Plating over all (Standard)
G=Gold Flash over all
(1000pcs per reel) (MOQ 5 reels)

Electrical 电气
Voltage Rating: 50V AC/DC max.
Current Rating: 0.4A AC/DC max.
Dielectric Strength: 250V AC for 1 minute
between adjacent terminal, no breakdown
Insulation Resistance: 50 MΩ min. 250V DC for 1 minute
between adjacent terminal
Contact Resistance: 40 mΩ max.

Part Number	FC2A30
Drawing Date	24th May 2010
By	AJO
Detail	FC2A30
Revision	E
Date	17/03/15
Tolerances (except as noted)	X.X ± 0.30 X.XX ± 0.15 X.XXX ± 0.10
Units:	Metric (mm)
3rd Angle Projection	Yes
ROHS COMPLIANT	2011/06/15
ROHS EXEMPT	2011/06/15
This drawing is confidential and copyright of Global Connector Technology, Ltd (GCT). This drawing must not be copied or disclosed without written consent E & OE	
Not to Scale	1/2
Drawn By	PKN
Sheet No.	1/2

Please contact GCT for non-tooled parts Non-tooled MOQ 10k pcs

Pin No.	Dim.A	Dim.B	Dim.C	Dim.D
* 4	7.6	6.5	1.50	2.60
* 5	8.1	7.0	2.00	3.10
* 6	8.6	7.5	2.50	3.60
* 7	9.1	8.0	3.00	4.10
* 8	9.6	8.5	3.50	4.60
* 9	10.1	9.0	4.00	5.10
* 10	10.6	9.5	4.50	5.60
* 11	11.1	10.0	5.00	6.10
* 12	11.6	10.5	5.50	6.60
* 13	12.1	11.0	6.00	7.10
* 14	12.6	11.5	6.50	7.60
* 15	13.1	12.0	7.00	8.10
* 16	13.6	12.5	7.50	8.60
* 17	14.1	13.0	8.00	9.10
* 18	14.6	13.5	8.50	9.60
* 19	15.1	14.0	9.00	10.10
* 20	15.6	14.5	9.50	10.60
* 21	16.1	15.0	10.00	11.10
* 22	16.6	15.5	10.50	11.60
* 23	17.1	16.0	11.00	12.10
* 24	17.6	16.5	11.50	12.60
* 25	18.1	17.0	12.00	13.10
* 26	18.6	17.5	12.50	13.60
* 27	19.1	18.0	13.00	14.10
* 28	19.6	18.5	13.50	14.60
* 29	20.1	19.0	14.00	15.10
* 30	20.6	19.5	14.50	15.60
* 31	21.1	20.0	15.00	16.10
* 32	21.6	20.5	15.50	16.60
* 33	22.1	21.0	16.00	17.10
* 34	22.6	21.5	16.50	17.60
* 35	23.1	22.0	17.00	18.10
* 36	23.6	22.5	17.50	18.60
* 37	24.1	23.0	18.00	19.10
* 38	24.6	23.5	18.50	19.60
* 39	25.1	24.0	19.00	20.10
* 40	25.6	24.5	19.50	20.60

* = Tooled Parts

GCT
Global Connector Technology
www.gct.co

X-ON Electronics

Largest Supplier of Electrical and Electronic Components

Click to view similar products for [FFC & FPC Connectors](#) category:

Click to view products by [GCT](#) manufacturer:

Other Similar products are found below :

[HFW11R-1STE1H1LF](#) [FH29B-100S-0.2SHW\(99\)](#) [FA5S008HP1](#) [FH29B-120S-0.2SHW\(99\)](#) [FH29B-80S-0.2SHW\(99\)](#) [FHS-16](#) [FPH-2022G](#)
[52610-1075](#) [52610-1275](#) [52610-1934](#) [XF3M\(1\)-1415-1B-R100](#) [501864-3091-TR225](#) [0525594033](#) [086210010340800](#) [086222026001800](#)
[52271-2869-CUT-TAPE](#) [62674-201121DLF](#) [62684-36210E9ALF](#) [52610-1675](#) [52746-1671-TR250](#) [10051922-2810EHLF](#) [6-520415-9](#)
[BD021-09A-A1-0350-0200-0550-LD](#) [SFV6R-1STE9HLF](#) [XF3M-2915-1B-R100](#) [1658549-1](#) [62674-221121ALF](#) [46214008010800](#)
[046298003000883](#) [151660622](#) [842-816-2630-035](#) [AYF530665TA](#) [AYF351525](#) [046296011930846+](#) [AYF352325A](#) [046254020000800+](#)
[FH19C-13S-0.5SH\(99\)](#) [FH39J-51S-0.3SHW\(99\)](#) [AYF355125A](#) [AYF530365TA](#) [FH29B-44S-0.2SHW\(99\)](#) [SFW5R-2STAE9LF](#) [AYF351125A](#)
[AYF350725A](#) [62684-502100AHLF](#) [FH39-61S-0.3SHW\(99\)](#) [AYF414035A](#) [10064555-172520HLF](#) [AYF212335A](#) [504754-2500](#)