

















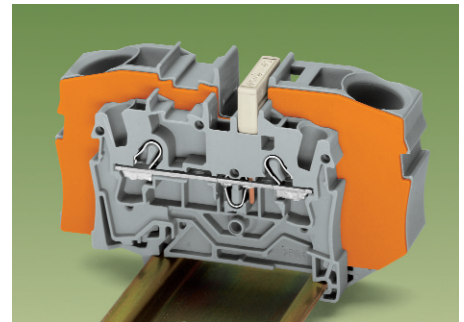
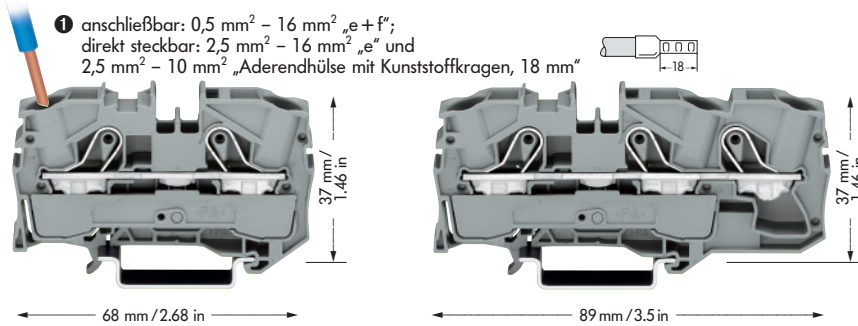

















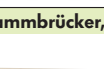
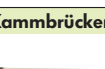

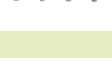
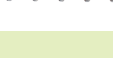

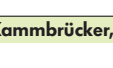







TOPJOB® S

Reihenklemmen 10 (16) mm²

Serie 2010











0,5 – 10 (16) mm² ① 800 V/8 kV/3 57 A Klemmenbreite 10 mm / 0.394 in  17 – 19 mm / 0.71 in * 	AWG 20 – 6 600 V, 65 A  600 V, 65 A 	0,5 – 10 (16) mm² ① 800 V/8 kV/3 57 A Klemmenbreite 10 mm / 0.394 in  17 – 19 mm / 0.71 in * 	AWG 20 – 6 600 V, 65 A  600 V, 65 A 	Reduzierbrücken Generell ist zu beachten: Der Summenstrom der Abgänge darf den Nennstrom des Reduzierbrückers/Kammbrückers nicht überschreiten.
--	---	--	---	---



Bestell-Nr.	Stück je Verp.-Einh.	Bestell-Nr.	Stück je Verp.-Einh.	Bestell-Nr.	Stück je Verp.-Einh.
2-Leiter-Durchgangsklemmen		3-Leiter-Durchgangsklemmen		Reduzierbrücken mit Reduzierbrücker	
grau 2010-1201 	25	grau 2010-1301 	25	Beim Reduzierbrücken ist immer eine Abschlussplatte zwischen den zu brückenden Klemmen zu setzen.	
blau 2010-1204 	25	blau 2010-1304 	25	Der Reduzierbrücker 2016-499 ist für das Reduzierbrücken von 16/10 mm ² auf 10/6/4/2,5 mm ² geeignet.	
orange 2010-1202 	25	orange 2010-1302 	25		
2-Leiter-Schutzleiterklemme		3-Leiter-Schutzleiterklemme		Die Reduzierbrücker werden – wie auch bei den Kammbrückern üblich – von oben in die zu brückenden Klemmen bis zum Anschlag hineingesteckt.	
grün-gelb 2010-1207 	25	grün-gelb 2010-1307 	25		
 Ex e II-Anwendungen in Vorbereitung		 Ex e II-Anwendungen in Vorbereitung			
 Für Ex i-Anwendungen geeignet		 Für Ex i-Anwendungen geeignet			
Zubehör passende Beschriftungssysteme WMB/Mini-WSB/Beschriftungstreifen (siehe Kapitel 14)					
Abschluss- und Zwischenplatte, 1 mm dick		Abschluss- und Zwischenplatte, 1 mm dick		Reduzierbrücker, lichtgrau, isoliert	
 orange 2010-1292 100 (4 x 25)		 orange 2010-1392 100 (4 x 25)		 57 A	
 grau 2010-1291 100 (4 x 25)		 grau 2010-1391 100 (4 x 25)		2016-499 50 (2 x 25)	
Kammbrücker, lichtgrau, isoliert, I_N 57 A		Kammbrücker, lichtgrau, isoliert, I_N 57 A			
 2-fach 2010-402 50 (2 x 25)		 2-fach 2010-402 50 (2 x 25)			
 3-fach 2010-403 50 (2 x 25)		 3-fach 2010-403 50 (2 x 25)			
 4-fach 2010-404 50 (2 x 25)		 4-fach 2010-404 50 (2 x 25)			
 5-fach 2010-405 50 (2 x 25)		 5-fach 2010-405 50 (2 x 25)			
Kammbrücker, lichtgrau, isoliert, I_N 57 A		Kammbrücker, lichtgrau, isoliert, I_N 57 A			
 1 - 3 2010-433 50 (2 x 25)		 1 - 3 2010-433 50 (2 x 25)			
 1 - 4 2010-434 50 (2 x 25)		 1 - 4 2010-434 50 (2 x 25)			
 1 - 5 2010-435 50 (2 x 25)		 1 - 5 2010-435 50 (2 x 25)			
Warnabdeckung, mit schwarzem Blitzpfeil, für 5 Klemmen		Warnabdeckung, mit schwarzem Blitzpfeil, für 5 Klemmen			
 gelb 2010-115 50 (2 x 25)		 gelb 2010-115 50 (2 x 25)			
Prüfadapter, für Prüfstecker 4 mm Ø		Prüfadapter, für Prüfstecker 4 mm Ø			
 2009-174 100 (4 x 25)		 2009-174 100 (4 x 25)			
Prüfabgriff, für max. 2,5 mm²		Prüfabgriff, für max. 2,5 mm²			
 2009-182 100 (4 x 25)		 2009-182 100 (4 x 25)			
Beschriftungstreifen, weiß, unbedruckt, auf Spule für mittige Beschriftung 11 mm breit		Beschriftungstreifen, weiß, unbedruckt, auf Spule für mittige Beschriftung 11 mm breit			
 50 m 2009-110 1		 50 m 2009-110 1			
 300 m 2009-130 1		 300 m 2009-130 1			

* Weitere Prüfzeichen und zugeordnete Zulassungsdaten siehe Kapitel 15.





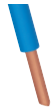



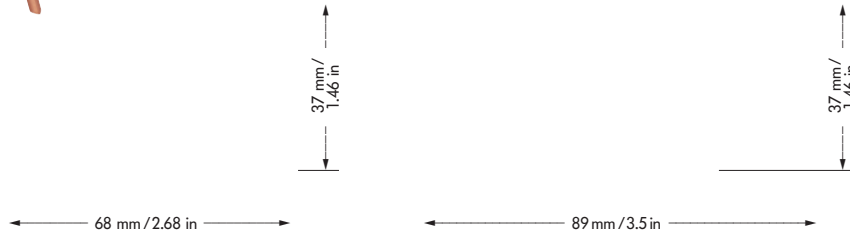
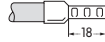

TOPJOB® S Rail-Mounted Terminal Blocks 10 (16) mm²/AWG 6 Series 2010

0.5 – 10 (16) mm² ① 800 V/8 kV/3 57 A Terminal block width 10 mm / 0.394 in  17 – 19 mm / 0.71 in *  	AWG 20 – 6 600 V, 65 A  600 V, 65 A 	0.5 – 10 (16) mm² ① 800 V/8 kV/3 57 A Terminal block width 10 mm / 0.394 in  17 – 19 mm / 0.71 in *  	AWG 20 – 6 600 V, 65 A  600 V, 65 A 	Commoning with step-down jumpers Note: The total current flowing must not exceed the rating of the step-down jumper/push-in type jumper bar.
---	---	---	---	--



① Push-in conductor sizes: AWG 14 – 6 (2.5 mm² – 16 mm²) "s" and AWG 14 – 8 (2.5 mm² – 10 mm²) "insulated ferrules, 18 mm"



Item No.	Pack.-unit pcs	Item No.	Pack.-unit pcs	Item No.	Pack.-unit pcs
2-conductor through terminal blocks		3-conductor through terminal blocks		Commoning with step-down jumpers	
grey 2010-1201 	25	grey 2010-1301 	25	An end plate must be applied between the two terminal blocks.	
blue 2010-1204 	25	blue 2010-1304 	25	Step-down jumper 2016-499 can be used for commoning AWG 8/6 (10/16 mm ²) terminal blocks with AWG 8/10/12/14 (10/6/4/2.5 mm ²) terminal blocks.	
orange 2010-1202 	25	orange 2010-1302	25	Step-down jumpers are simply pushed down to full insertion, in the same way as all other push-in type jumper bars.	
2-conductor ground (earth) terminal block		3-conductor ground (earth) terminal block			
green-yellow 2010-1207 	25	green-yellow 2010-1307	25		
 Ex e II applications are being prepared		 Ex e II applications are being prepared			
 Suitable for Ex i applications		 Suitable for Ex i applications			
Accessories appropriate marker system WMB/Miniature WSB/Marker strips (see section 14)					
End and intermediate plate , 1 mm / 0.039 in thick		End and intermediate plate , 1 mm / 0.039 in thick		Step-down jumper , light grey, insulated	
orange 2010-1292 100 (4 x 25)		orange 2010-1392 100 (4 x 25)		57 A	
grey 2010-1291 100 (4 x 25)		grey 2010-1391 100 (4 x 25)		2016-499	50 (2 x 25)
Push-in type jumper bars , light grey, insulated, I _N 57 A		Push-in type jumper bars , light grey, insulated, I _N 57 A			
2-way 2010-402 50 (2 x 25)		2-way 2010-402 50 (2 x 25)			
3-way 2010-403 50 (2 x 25)		3-way 2010-403 50 (2 x 25)			
4-way 2010-404 50 (2 x 25)		4-way 2010-404 50 (2 x 25)			
5-way 2010-405 50 (2 x 25)		5-way 2010-405 50 (2 x 25)			
Push-in type jumper bars , light grey, insulated, I _N 57 A		Push-in type jumper bars , light grey, insulated, I _N 57 A			
1 - 3 2010-433 50 (2 x 25)		1 - 3 2010-433 50 (2 x 25)			
1 - 4 2010-434 50 (2 x 25)		1 - 4 2010-434 50 (2 x 25)			
1 - 5 2010-435 50 (2 x 25)		1 - 5 2010-435 50 (2 x 25)			
Protective warning marker , for 5 terminal blocks		Protective warning marker , for 5 terminal blocks			
yellow 2010-115 100 (4 x 25)		yellow 2010-115 100 (4 x 25)			
Test plug adapter , for test plug 4 mm Ø		Test plug adapter , for test plug 4 mm Ø			
2009-174 100 (4 x 25)		2009-174 100 (4 x 25)			
Testing tap , for max. 2.5 mm ²		Testing tap , for max. 2.5 mm ²			
2009-182 100 (4 x 25)		2009-182 100 (4 x 25)			
Marker strip , white, plain		Marker strip , white, plain			
for center marking		for center marking			
11 mm / 0.433 in wide		11 mm / 0.433 in wide			
50 m 2009-110	1	50 m 2009-110	1		
on roll 300 m 2009-130	1	on roll 300 m 2009-130	1		

* For further approvals with corresponding ratings see section 15.

TOPJOB® S

Bornes sur rail 10 (16) mm²

Série 2010

<p>0,5 – 10 (16) mm² ⓪ 800 V/8 kV/3 57 A</p> <p>Largeur des bornes 10 mm / 0.394 in L 17 – 19 mm / 0.71 in</p> <p>* U 2</p>	<p>AWG 20 – 6 600 V, 65 A U 600 V, 65 A Z</p>	<p>0,5 – 10 (16) mm² ⓪ 800 V/8 kV/3 57 A</p> <p>Largeur des bornes 10 mm / 0.394 in L 17 – 19 mm / 0.71 in</p> <p>* U 2</p>	<p>AWG 20 – 6 600 V, 65 A U 600 V, 65 A Z</p>	<p>Pontage avec pont réducteur</p> <p>Remarque : D'une manière générale, le courant total des sorties ne doit pas dépasser le courant nominal du pont réducteur/peigne de pontage.</p>
---	--	---	--	---

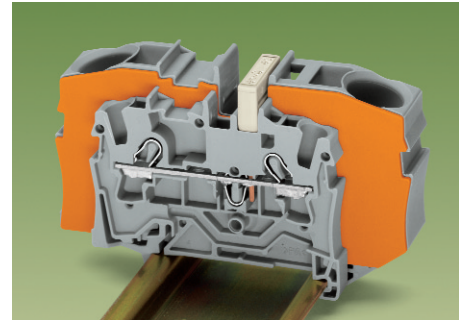
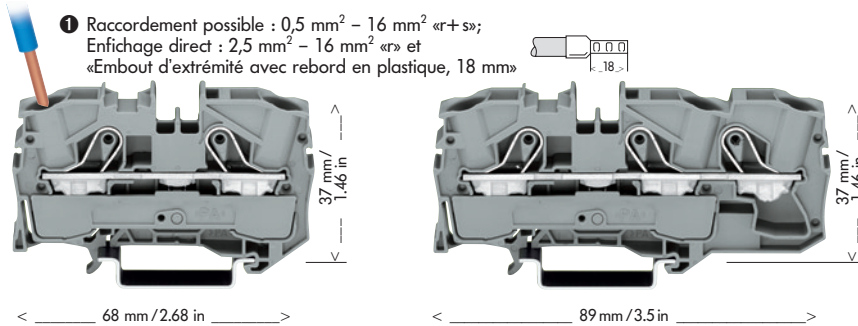

N° de produit	Unité d'emballage	N° de produit	Unité d'emballage	N° de produit	Unité d'emballage
Bornes de passage pour 2 conducteurs		Bornes de passage pour 3 conducteurs		Pontage avec pont réducteur	
gris 2010-1201	25	gris 2010-1301	25	Lors du pontage avec pont réducteur, il faut toujours prévoir une plaque d'extrémité entre les bornes à ponter.	
bleu 2010-1204	25	bleu 2010-1304	25	Le pont réducteur 2016-499 est prévu pour le pontage des bornes de 16/10 mm ² à 10/6/4/2,5 mm ² .	
orange 2010-1202	25	orange 2010-1302	25	Comme pour les peignes de pontage, les ponts réducteurs sont enfichés par le haut dans les bornes à ponter jusqu'à la butée.	
Borne de protection pour 2 conducteurs		Borne de protection pour 3 conducteurs			
vert-jaune 2010-1207	25	vert-jaune 2010-1307	25		
④ Applications Ex e II en préparation		④ Applications Ex e II en préparation			
② pour applications Ex i		② pour applications Ex i			
Accessoires Système de marquage WMB/Mini-WSB/Bandes de repérage (voir chapitre 14)					
Plaque d'extrémité et intermédiaire, épaisseur 1 mm		Plaque d'extrémité et intermédiaire, épaisseur 1 mm		Pont réducteur, gris clair, isolé	
orange 2010-1292	100 (4 x 25)	orange 2010-1392	100 (4 x 25)	57 A	
gris 2010-1291	100 (4 x 25)	gris 2010-1391	100 (4 x 25)	2016-499 50 (2 x 25)	
Peigne de pontage enfichable, gris clair, isolé, I_N 57 A		Peigne de pontage enfichable, gris clair, isolé, I_N 57 A			
2 pôles 2010-402	50 (2 x 25)	2 pôles 2010-402	50 (2 x 25)		
3 pôles 2010-403	50 (2 x 25)	3 pôles 2010-403	50 (2 x 25)		
4 pôles 2010-404	50 (2 x 25)	4 pôles 2010-404	50 (2 x 25)		
5 pôles 2010-405	50 (2 x 25)	5 pôles 2010-405	50 (2 x 25)		
Peigne de pontage enfichable, gris clair, isolé, I_N 57 A		Peigne de pontage enfichable, gris clair, isolé, I_N 57 A			
1 - 3 2010-433	50 (2 x 25)	1 - 3 2010-433	50 (2 x 25)		
1 - 4 2010-434	50 (2 x 25)	1 - 4 2010-434	50 (2 x 25)		
1 - 5 2010-435	50 (2 x 25)	1 - 5 2010-435	50 (2 x 25)		
Couverture protectrice de signalisation de danger, pour 5 bornes		Couverture protectrice de signalisation de danger, pour 5 bornes			
jaune 2010-115	50 (2 x 25)	jaune 2010-115	50 (2 x 25)		
Adaptateur de test, pour fiche de contrôle Ø 4 mm		Adaptateur de test, pour fiche de contrôle Ø 4 mm			
2009-174	100 (4 x 25)	2009-174	100 (4 x 25)		
Prise de test pour 2,5 mm² max.		Prise de test pour 2,5 mm² max.			
2009-182	100 (4 x 25)	2009-182	100 (4 x 25)		
Bandes de marquage, blanches, vierges, en rouleau pour marquage central largeur 11 mm		Bandes de marquage, blanches, vierges, en rouleau pour marquage central largeur 11 mm			
50 m 2009-110	1	50 m 2009-110	1		
300 m 2009-130	1	300 m 2009-130	1		

* Pour d'autres approbations avec les données techniques correspondantes, voir chapitre 15.

X-ON Electronics

Authorized Distributor

Click to view similar products for [Wago manufacturer](#).

Other Similar products are found below :

[02330505](#) [02330506](#) [02330510](#) [02330524](#) [02360402](#) [02360403](#) [02360404](#) [02360406](#)

[02530003K051225300000100](#) [02530003K051225300000200](#) [02560402](#) [02560403](#)

[02560404](#) [02560405](#) [02560406](#) [02560408](#) [02800402](#) [02800681](#) [02800687](#) [02800833](#)

[02800870](#) [02800907](#) [02810611](#) [0281061102810418RN010000](#) [02810623](#)