

62 GB- Series Plugs

Miniature Bayonet Lock Connectors
Complies with MIL-C-26482

CE-2Pa

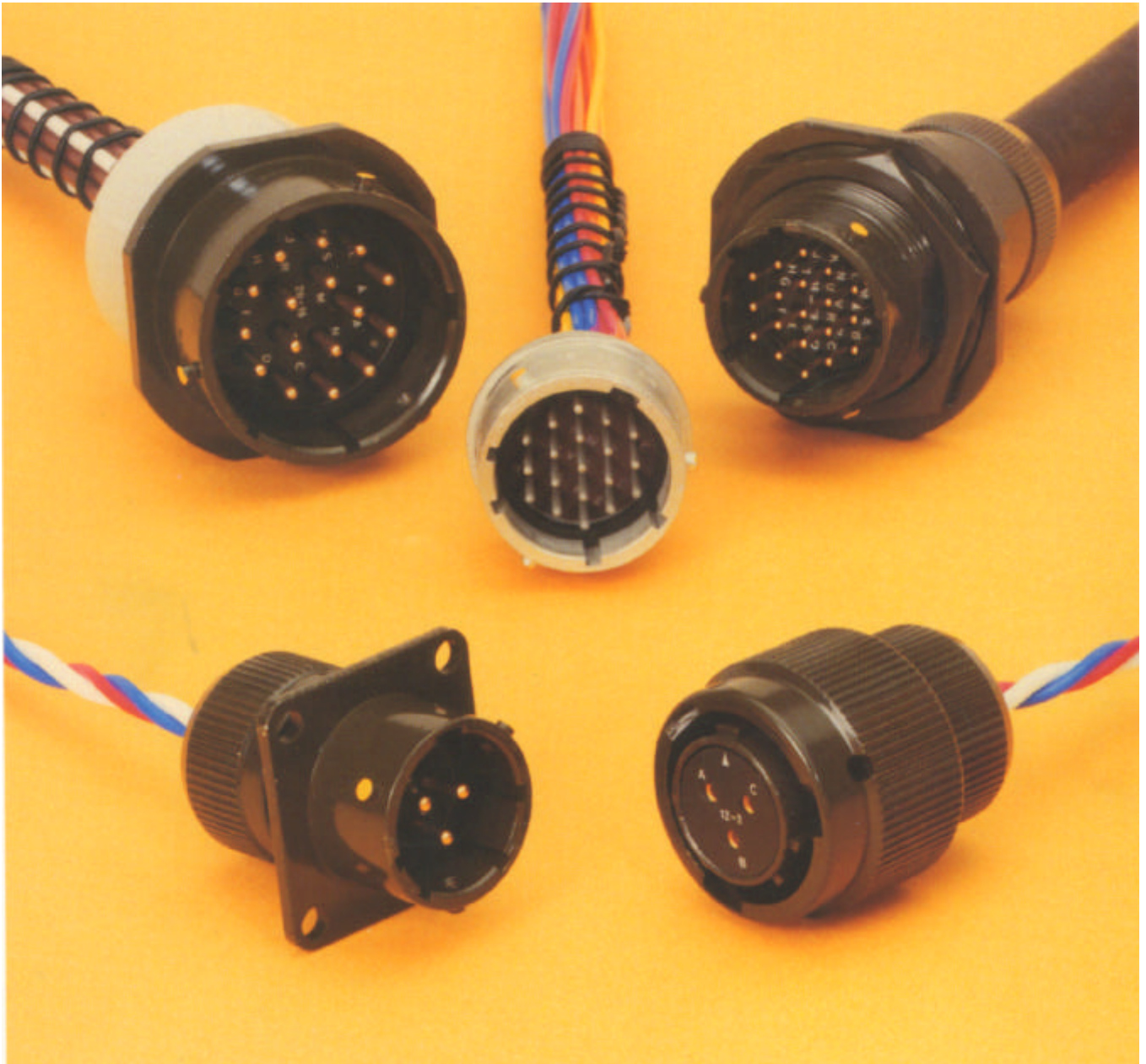

This miniature bayonet lock connector series offers designers important features not found in any other range of connectors.

They are developed and manufactured entirely in the U.K. by AMPHENOL Ltd., and have full qualification approval to British Standards Specification BS 9522 F0017 and British Defence Specification DEF STAN 59-35 (Part 3) Sec. 7.

This catalogue to be used in conjunction with Catalogues:
CE-2Ra – 62GB Series Receptacles
CE-2Aa – 62GB Series Accessories

Amphenol

62GB and Pattern 608 New Planforms

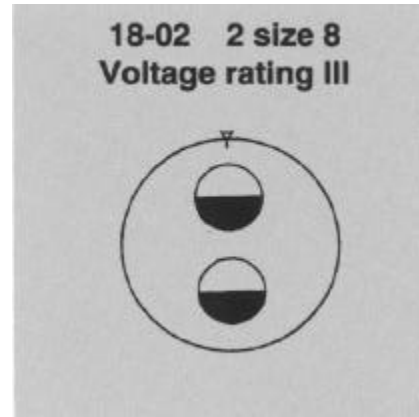
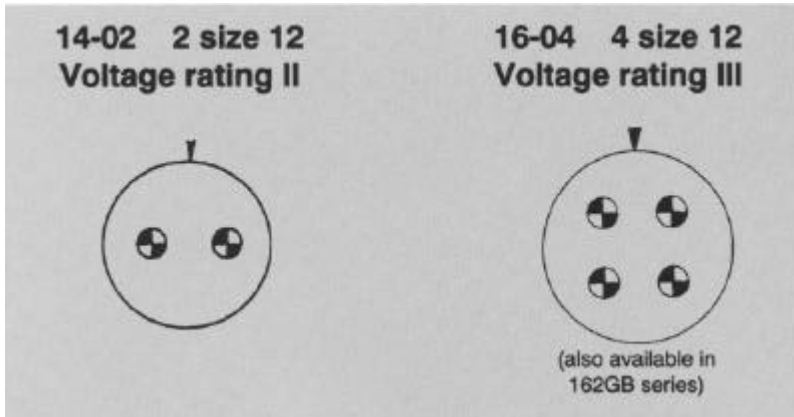

Current:

- (a) Maximum current per individual contact (in isolation)* at ambient temperature of 85°C
Contact size 12: 23 A
- (b) Maximum current per contact through all contacts simultaneously at an ambient temperature of 85°C
Contact size 12: 20 A

Current:

- (a) Maximum current per individual contact (in isolation)* at ambient temperature of 85°C
Contact size 8: 45 A
- (b) Maximum current per contact through all contacts simultaneously at an ambient temperature of 85°C
Contact size 8: 40 A

	Sea level 1013 mbar á			8500m (27,900ft) 320 mbar			21,340m (70,000ft) 44 mbar		
	I	II	III	I	II	III	I	II	III
Voltage rating Working voltages ** (nominal)	700	1200	1500	550	650	800	330	380	450
d.c. or a.c. peak Voltage proof d.c. or a.c. peak	2100	3000	3000	1100	1300	1300	660	760	750

* i.e. when only one contact per connector is electrically loaded.

á 1 mbar=10² N/m²=100 Pa

** Establishment of electrical safety factors is the responsibility of the user

CONTENTS

Page

Amphenol 62GB Solder Connectors	4
Schedule of Tests	5-6
Connector Styles Available	7
Insert Availability	8
Ordering 62GB Series Connectors	10-11
Plugs - Table of Styles	12-13
Plugs	14-19
Insert Orientations	20
Key/Keyway Orientations	21

Amphenol® 62GB solder connectors

This catalogue to be used in conjunction with Catalogues:
CE-2Ra – 62GB Series Receptacles
CE-2Aa – 62GB Series Accessories

This miniature bayonet lock connector series offers designers important features not found in any other range of connectors. The range has full qualification approval to British Standards Specification BS 9522 FOO 17 and British Defence Specification DEF STAN 59-35 (Part 3) Sec. 7.

62GB Series connectors - developed and manufactured entirely in the United Kingdom by Amphenol Limited. They are the first and only British connectors to have achieved this. A doubly strong position which Amphenol are well geared to handle. The manufacturing facilities of the Whitstable plant have been cited as exemplary in Europe. Certainly the layout is extensive and extremely efficient; safety awards have been attained every time returns have been submitted to the British Safety Council.

62GB Series connectors have been well established with Government authorities on an international scale and users can be found in Sweden, Denmark, Norway, Finland, Germany, Spain, Holland, India, Canada and Italy.

Derating

Connectors must be derated under the following operating conditions:

1. At elevated ambient temperatures, the current ratings are reduced so that total maximum hot spot temperature of 125°C is not exceeded.
2. At high altitudes, revised voltage ratings become effective as shown on page 7.
3. When connectors to different specifications are intermated (e.g. BS 9522 FOO 17 and MIL-C26482), the combination must not be operated under conditions more severe than the less stringent clause of either specification.

Amphenol 62GB connectors are designed to meet the most stringent requirements of both specifications.

Military Specifications

British Standards Specification BS 9522 FOO 17 closely corresponds to the United States Military Specification MIL-C-26482 solder terminations. Certain differences exist between the schedules which can be seen on pages 2 and 3.

Approved gauges are used to check interchangeability of 62GB series with other connectors manufactured to BS 9522 FOO 17 or MIL-C-26482.

Basic Construction

Connector shells are machined from solid aluminium bar stock - not forged or extruded as in competitive designs. Machining has inherent advantages in terms of strength and adaptability. 62GB Series can be supplied in brass or stainless steel, for instance.

The normal shell finish used, which has a high resistance to corrosion, is zinc cobalt olive drab. Other finishes may be supplied to special order, such as cadmium plate which is available by adding deviation (714) to the end of part number.

Inserts are of polychloroprene rubber compounded to an Amphenol specification. Operating temperature range is -55°C to 125°C, and the connectors have gold-plated contacts designed for soldered connections. Configurations for size 20 contacts range between 2 contacts in the size 8 12.7mm (0.5in diameter) shell up to a maximum of 61 contacts in the size 2436.1 mm (1.5in diameter) shell. Intermediate sizes, and contact data for heavier current ratings are shown in the insert availability chart on page 6 and 7.

Hermetic connectors with glass sealed dielectric are manufactured with mild steel shells and nickel iron contacts plated tin over copper.

* Other finishes are available on request.

Protection Against Mis-Mating or Cross-Plugging

In BS 9522 FOO 17 positive shell-to-shell keying is provided with keys and keyways in a choice of either the normal (N) or any of the four preferred alternate positions: B, C, E and F. This prevents mismating between shells of different orientations and overcomes the difficulties associated with rotated inserts and a standard key-keyway orientation. In the latter system, damage to the inserts or contacts can result if excessive force is used to engage non-mating pairs.

Rotated inserts are, however, permissible in BS 9522 FOO 17 connectors if required to mate with or replace units to MIL-C-26482 mounted in existing equipment. Connectors have normal orientations manufactured to BS 9522 FOO 17 or MIL-C-26482 are fully intermateable as also are connectors with inserts in positions W, X, Y or Z.

Schedule of Tests Required for Qualification Approval

Tests	Brief Description
Visual Examination	
Dimensions, outline mass(including contacts) Compatability Gauging procedure	
Polarization	
Engaging and separating force, connector	Engagement max: 0,90 Nm (8.0 lbf.in.) to 4,97 Nm (44 lbf.in.) according to shell size. Separation min: 0,22 Nm (2.0 lbf.in.) to 1,58 Nm (14.0 lbf.in.) according to shell size.
Contact Holding Force	0,21 N (0.047 lbf) min.size 20 0,56 N (0.126 lbf)min. size 16
Sealing (air pressure)	Max leakage 28,53 uNm/s (1 cm3/h), 1 bar (14.5 p.s.i.) differential.
Sealing Hermetic	Hermetic receptacles have a max leak of 0.1 micron cubic foot per hour (1 x 10-6Cm3/s)
Contact Resistance	5 milliohms max.
Housing (Shell) Continuity	200 milliohms max. 5 milliohms max. grounding spring styles.
Insulation Resistance	5,000 Megaohms at 500 - 50 V d.c.
Voltage Proof	See page 7. Duration 1 minute
Soldering	As BS 9520: 1974, Clause 1.2.6.6, Method 2.
Bumping	As BS 9520: 1974, Clause 1.2.6.1. 4,000 -10 bumps / 390m / s2 (40 gn).
Vibration	As BS 9520: 1974, Clause 1.2.6.2.1. Procedure A. 10 Hz to 5000 Hz, 0.75 mm / 10 gn.
Shock	As BS 9520: 1974, Clause 1.2.6.3. 981 m/s2 (100 g n).
Acceleration (Steady State)	As BS 9520: 1974, Clause 1.2.6.4. 490 m/s2 (50 gn).
Rapid Change of Temperature	As BS 9520: 1974, Clause 1.2.6.7. -550 C to - 1250 C.
Climatic Sequence	As BS 9520: 1974, Clause 1.2.6.11. Severity 55/125/56.
Flammability	As BS 9520: 1974, Clause 1.2.6.8. Direct flame applied, duration 1 minute.
Damp Heat (Steady State)	As BS 9520: 1974, Clause 1.2.6.14. Severity 56 days.

Schedule of Tests Required for Qualification Approval

Tests	Brief Description
Immersion (at low air pressure)	3 cycles at 30 mins each cycle, total immersion in water at pressure 44 m bar.
Mechanical Endurance	500 operations minimum
High Temperature Endurance	Long term: 1,000 hrs. at 850 C ambient carrying the specified current. Short term: 250 hrs at 1250 C, no current.
Mould Growth	As BS 9520: 1974, Clause 1.2.6.15. 28 days duration.
Salt Mist	As BS 9520: 1974, Clause 1.2.6.16. Severity 1.
Dust	As BS 9520: 1974, Clause 1.2.6.17. Exposure 30 minutes.
Robustness of Terminations	44,5 N (101bf) size 16 22,2 N (5 lbf) size 20
Contact Retention (in insert)	67,0 N (15 lbf) min. size 20 112,0 N (25 lbf) min. size 16
Insert Retention (in shell)	517 KN1m2 (751bf/in2) min.
Test Prod Damage	Moment: 0,056 Nm (0.5 lbf in) size 20 0,225 Nm (2 lbf in) size 16
Impact	Five impacts, drop height 1 m (3ft.3 in.).
Grounding Spring Holding Force Plugs with grounding springs only.	1,17 N (0.263 lbf) to 2,74 N (0.616 lbf) according to size.
Fluid Resistance	Immersion in 4 solvents and 9 fluids including aircraft fuels, lubricating oils and hydraulic fluids.
Compass Safe Distance	As BS 9520: 1974, Clause 1.2.5.11. 127 mm (5.0 in) min.

Connector Styles Available

Plugs

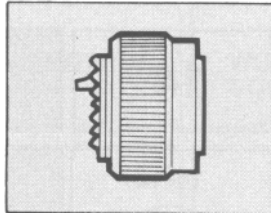

Straight Plug
See Pages 14-17

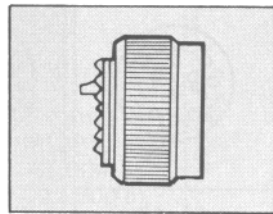

Grounded Plug
See Page 14

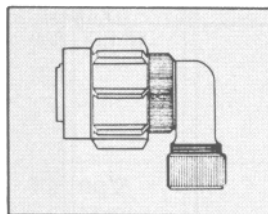

Audio Plug
See Page 18

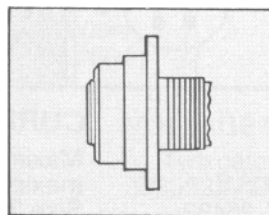

Push on - Pull off
See Page 19

Accessories

See Catalogue CE-2Aa

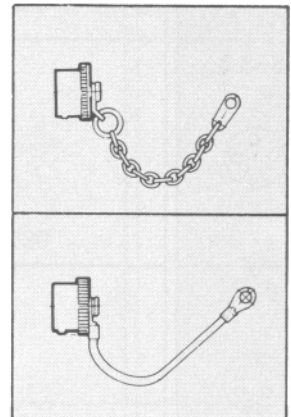

Insert Availability

8	10	12	14	16	18	20
8-2* 	10-6 	12-10 	14-12† 	16-23* 	18-32 	20-41
8-3* 	10-7 		14-15 	16-26 		
8-3 3 			14-19 			
8-4* 						
8-98 	10-2 	12-3 	14-5 	16-8 	18-11 	20-16

NOTES

* This insert arrangement is not included in B.S. spec., but is available and listed in MIL-C-26482.

† Due to the arrangement of contacts in the 14-12 insert arrangement it is classified, for current derating, in the shell size range 18-24.

Lettering of inserts shown above corresponds to view of front (mating surface of pin inserts or rear face (cable accessory end) of socket inserts.

KEY ● No 16 size contacts
○ No 20 size contacts

CURRENT RATING

Maximum current per individual contact (in isolation) at a maximum ambient temperature of 85°C: Size 20 contact 7.5A Size 16 contact 13-OA The performance of 62GB Series connectors at all times exceeds the maximum continuous bunched rating of the appropriate size wire, or cable of equivalent temperature rating. This bunched rating is therefore the determining factor. In the case of mixed loadings, the greatest individual load shall be the bunched loading. In any combination of ambient temperature plus temperature rise due to current flow through the contacts, the maximum connector internal hot spot temperature of 125°C must not be exceeded.

That is, when only one contact per connector is loaded.

Insert Availability

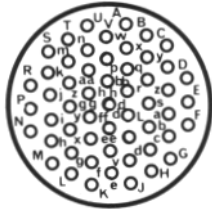
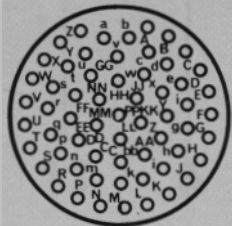
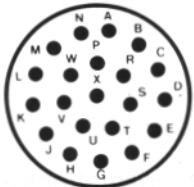
		VOLTAGE RATINGS			
22	24	ALTITUDE	D.C. WORKING VOLTAGE	A.C. WORKING VOLTAGE R.M.S.	PROOF VOLTAGE D.C. OR A.C. PEAK
<p>22-55</p> 	<p>24-61</p> 	<p>Rating 1 Sea level</p> <p>300 mb at 20°C 8,500m (27,800 ft)</p> <p>44 mb at 20°C 20,000m (66,000 ft)</p>	700	500	2100
<p>22-21</p>  <p>† Available to special order only</p>		<p>Rating 2 Sea level 300 mb at 20°C 8,500m (27,800 ft) 44 mb at 20°C 20,000m (66,000 ft)</p>	120	850	3000
			650	460	1300
			380	270	760

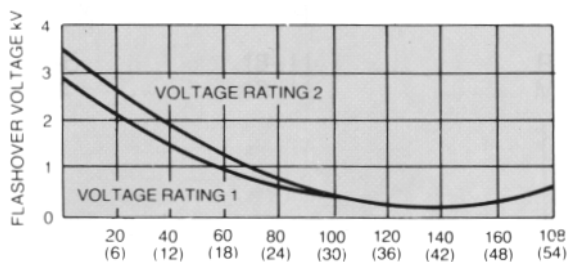

ALTITUDE-THOUSANDS OF FEET (METRES)
Relationship between flashover voltage and altitude for each voltage rating

VOLTAGE RATINGS

Two categories of voltage rating are specified in BS9522 F0017, F0038 and N0001.

Rating 1 (700V d.c. working at sea-level) Applicable to the high contact density inserts shown in the upper section of the insert availability diagram above.

Rating 2 (1200V d.c. working at sea-level) Applicable to the inserts shown in the lower section of the insert availability diagram.

Altitude derating. Information on voltage derating for operation at altitudes above sea-level can be obtained from the flashover voltage altitude curves on the left.

Ordering 62GB Series Connectors

To obtain the specific connector required write down the connector number from the typical example below. Only inserts shown in the availability chart on p. 10&11 can be specified. All connectors are delivered with protective dust covers

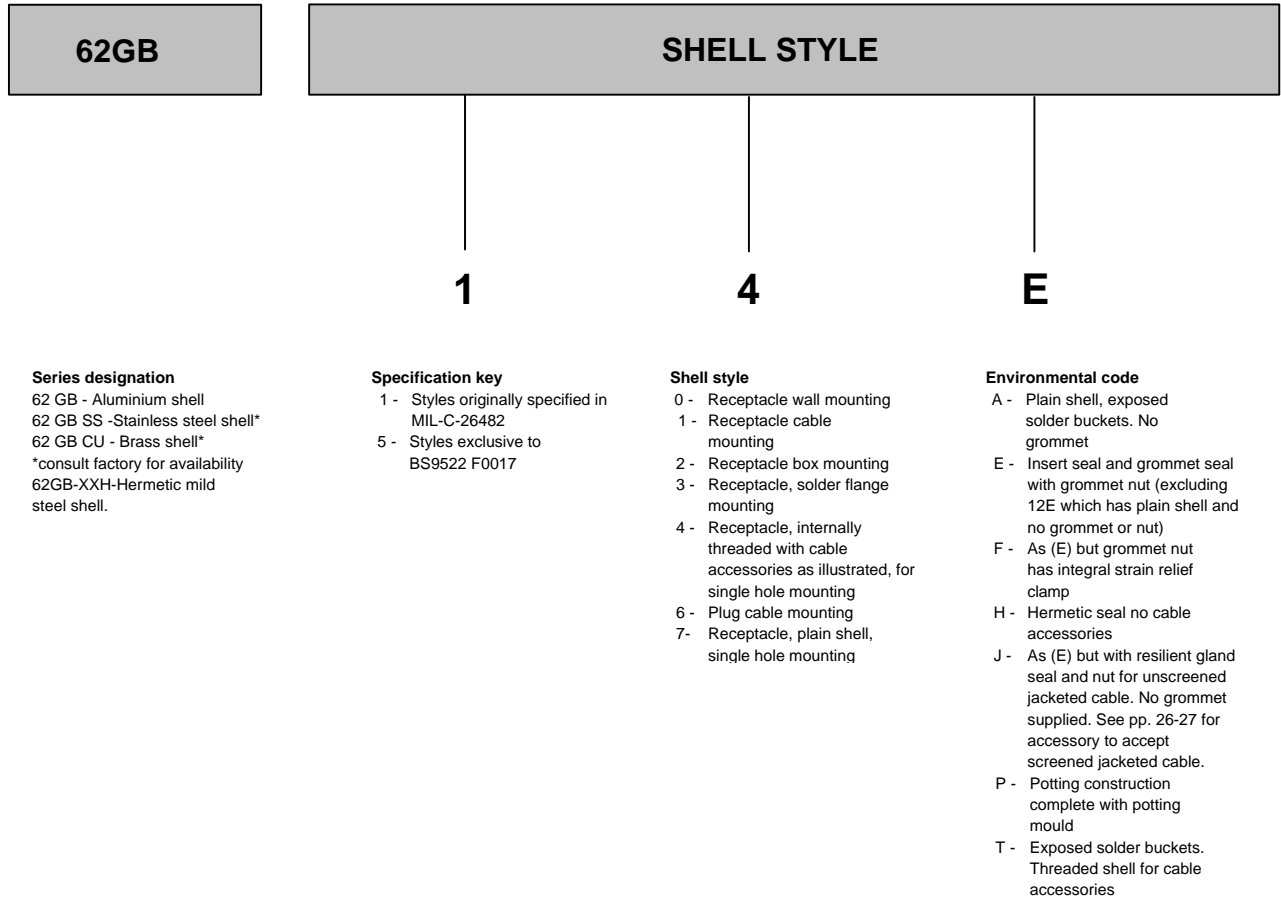

HOW TO ORDER FROM MS CONNECTOR NUMBERS

Connector numbers in the AMPHENOL and MS numbering systems. Only alternative insert orientations are specified in MIL-C-26482 which does not include alternative key/keyway orientations.

MS31	-	14	E	18 -11	P	X
62GB	-	14	E	18 -11	P	X

Ordering 62GB Series Connectors

INSERT ARRANGEMENT

18

11

P

B

(044)

Shell size (in sixteenths of an inch) 8, 10, 12, 14, 16
18,20,22,24

Number of contacts
2, 3, 4, 5, 6, 7, 8, 10, 11, 12,
16, 19, 21, 23, 26, 32, 41, 55,
61
* consult factory for availability

Contact Style
P - Pins
S - Sockets For hermetic connectors. P3 denotes pin contacts with solder bucket terminations. (Standard range). P2 denotes pin contacts with flattened and pierced terminations. (Special order).

Orientation
(Omit if normal orientation)
Keys/Keyways: A', B, C, D', E, F, (see p. 31)
Inserts: W,X,Y,Z.(see p56/57)
*Inactive for new designs

Deviations
(044) Rough grip heavy duty coupling ring.
(046) Box mounting plug.
(214) Fitted with extension back shell and strain relief clamp without grommet on F types only
(218) Lever coupling ring
(219) Contacts for flexible punted wrung (57A and 12E only)
(639) Bright cadmium plated shells
(345) Contacts for flexible punted wiring 12H,13H 17H only
(276) Hermetics with gold plated contacts.
(608) Black anodise.
(416) Electroless nickel
(714) Cadmium plate olive drab

HOW TO ORDER FROM B.S. CONNECTOR NUMBERS

Select the connector style by reference to BS9522 F0017 using the code below for identification. Note that the B.S. Specification includes only certain connectors from the table of styles as shown on pp. 8 & 9. Alternative key/keyway orientations are preferred in the BS9522 F0017 Specification to prevent mis-mating. However, rotated inserts are permissible where connectors are required to mate with or replace items to MIL-C-26482 on existing equipment.

62GB - 14E
C2098

18-11
18 11

P
M

B
B

O

Style

Insert Arrangement, see above

M - Pin contacts
F - Socket contacts



Alternative Key/Key way Orientation

Variant.
O - Standard connector

Plugs

Table of Styles

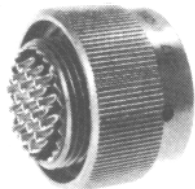
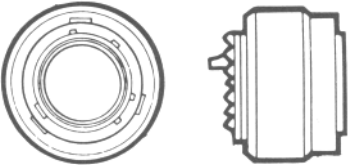
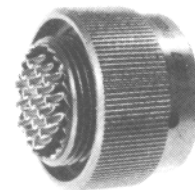
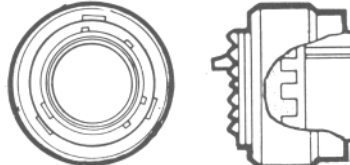
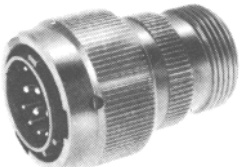
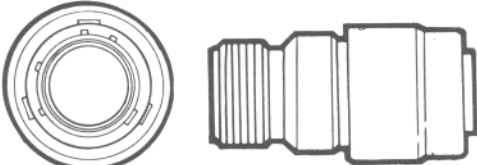
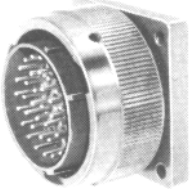
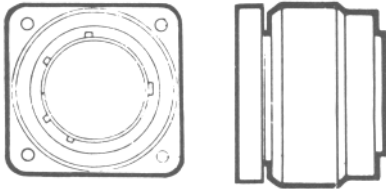
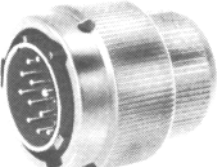
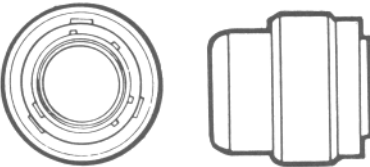
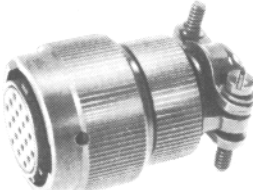
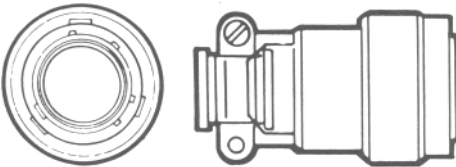
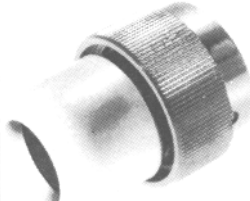

Page No.

62GB-56T			14
62GB-56TG			14
62GB-16A			15
62GB-56T (046)			15
62GB-16E			16
62GB-16F			16
62GB-16P			17

Plugs

Table of Styles

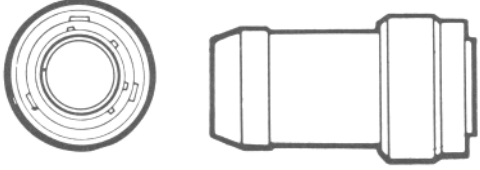
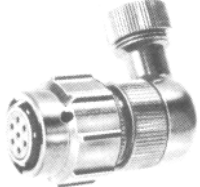
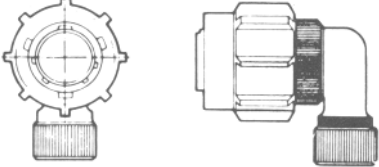
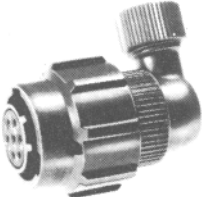
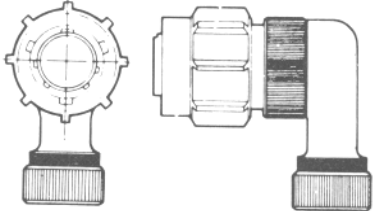
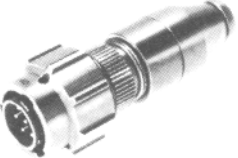
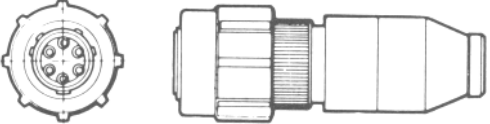
Page No.

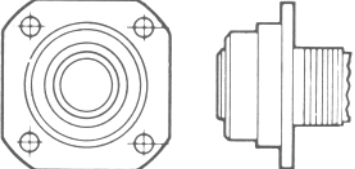
62GB-16J			17
62GB-5039-10			18
62GB-5055-10			18
62GB-5056-10			18
62GB-5074			19

Plugs

56T

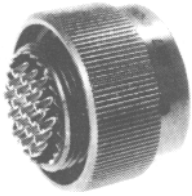

62GB-56T
BS9522 F0017 C2092

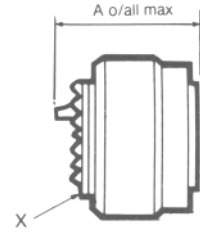
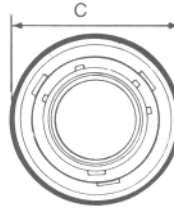

Basic plug with threaded shell to accept standard cable accessories

Shell Size	A Max	C max	X Thread
08	0.976 24.79	0.750 19.05	7/16 - 28 UNEF
10	0.976 24.79	0.859 21.82	9/16 - 24 NEF
12	0.976 24.79	1.031 26.19	11/16 -24NEF
14	0.976 24.79	1.156 29.36	13/16 - 20 UNEF
16	0.976 24.79	1.281 32.54	15/16 - 20 UNEF
18	0.976 24.79	1.391 35.33	1.1 /16 - 18 NEF
20	0.976 24.79	1.531 38.89	1.3/16 - 18 NEF
22	0.976 24.79	1.656 42.06	1.5/16 - 18 NEF
24	0.976 24.79	1.777 45.14	1.7/16 - 18 NEF

56TG

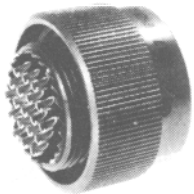

62GB-56TG
BS9522 F0017 C2093

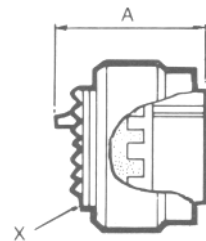
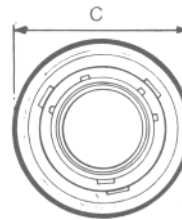

Basic plug with threaded shell to accept standard cable accessories. Has shell grounding spring fingers

Shell Size	A max	C max	X Thread
08	0.976 24.79	0.750 19.05	7/16 - 28 UNEF
10	0.976 24.79	0.859 21.82	9/16 - 24 NEF
12	0.976 24.79	1.031 26.19	11/16 - 24 NEF
14	0.976 24.79	1.156 29.36	13/16 - 20 UNEF
16	0.976 24.79	1.281 32.54	15/16 - 20 UNEF
18	0.976 24.79	1.391 35.33	1.1 /16 - 18 NEF
20	0.976 24.79	1.531 38.89	1.3/16 - 18 NEF
22	0.976 24.79	1.656 42.06	1.5/16 - 18 NEF
24	0.976 24.79	1.777 45.14	1.7/16 - 18 NEF

Plugs

16A



62GB-1 6A

Plug with general duty back shell.
No grommet provided.

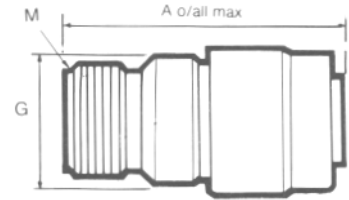

Shell Size	A max	C max	G max	M Thread
08	1.614	0.750	0.561	1/2 - 28 UNEF
	41.00	19.05	14.25	
10	1.614	0.859	0.686	5/8 - 24 NEF
	41.00	21.82	17.43	
12	1.614	1.031	0.811	3/4 - 20 UNEF
	41.00	26.19	20.60	
14	1.614	1.156	0.936	7/8 - 20 UNEF
	41.00	29.36	23.78	
16	1.614	1.281	1.061	1 - 20 UNEF
	41.00	32.54	26.95	
18	1.614	1.391	1.186	1.3/16 - 18 NEF
	41.00	35.33	30.13	
20	1.614	1.531	1.311	1.3/16 - 18 NEF
	41.00	38-89	33.30	
22	1.614	1.656	1.436	1.7/16 - 18 NEF
	41.00	42.06	36.75	
24	1.658	1.777	1.561	1.7116 - 18 NEF
	42.11	45.14	39.65	

56T



62GB-56T(046)

Box-mounting plug. Available for shell size 16:
other sizes to special order. Cable accessories
cannot be fitted.

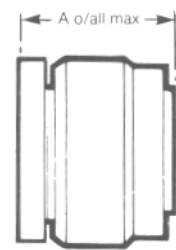
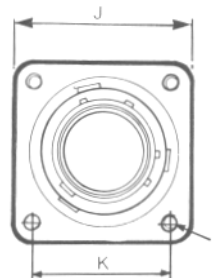

Shell Size	A max	J max	K	L
16	1.042	1.317	1.000	6.32 NC
	26.47	33.45	25.40	
20	1.042	1.625	1.250	6.32 NC
	26.47	41.28	31.75	
22	1.042	1.625	1.250	6.32 NC
	26.47	41.28	31.75	

Plugs

16E

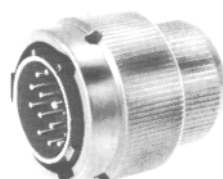

62GB-16E

MIL - C26482 MS3116E

Plug with grommet and grommet nut

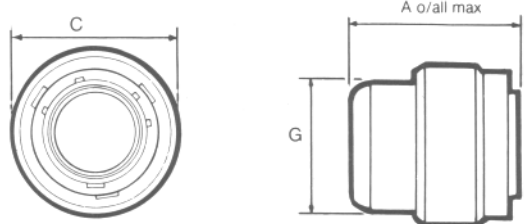

Shell Size	A max	C max	G max
08	1.281	0.750	0.561
	32.54	1.05	14.25
10	1.281	0.859	0.686
	32.54	21.82	17.431
12	1.281	1.031	0.811
	32.54	26.19	20.60
14	1.281	1.156	0.936 l
	32.54	29.36	23.78
16	1.281	1.281	1.061
	32.54	32.54	26.95
18	1.281	1.391	1.186
	32.54	35.33	30.13
20	1.281	1.531	1.311
	32.54	38.89	33.30
22	1.281	1.656	1.436
	32.54	42.06	36.75
24	1.281	1.777	1.561
	32.54	45.14	39.65

16F



62GB-16F

MIL - C26482 MS3116F

Plug with grommet and grommet nut fitted with integral strain relief clamp.



Shell Size	A max	C dia max	G dia max	H ± 0.005 (± 0.13)
08	1.752	0.750	0.828	0.156
	44.50	19.05	21.03	3.96
10	1.752	0.859	0.891	0.188
	44.50	21.82	22.63	4.78
12	1.752	1.031	1.016	0.312
	44.50	26.19	25.81	7.93
14	1.726	1.156	1.141	0.375
	43.84	29.36	28.97	9.53
16	1.866	1.281	1.203	0.500
	47.40	32.54	30.56	12.70
18	1.866	1.391	1.426	0.625
	47.40	35.33	36.22	15.88
20	2.040	1.531	1.426	0.625
	51.81	38.89	36.22	15.88
22	2.040	1.656	1.567	0.750
	51.81	42.06	39.80	19.05
24	2.178	1.777	1.735	0.800
	55.32	45.14	44.07	20.32

Plugs

16P

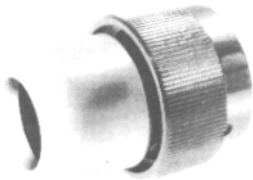

62GB-16P
MIL-C26482 MS3116P

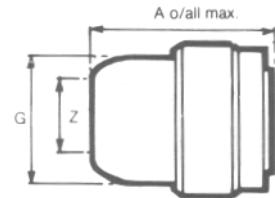
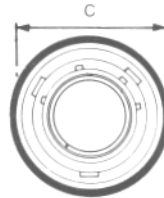

For potted seal. Supplied complete with detachable potting mould and location ring.

Shell Size	A max	C max	G max	Z min
08	1.306 33.17	0.750 19.05	0.572 14.53	0.260 6.60
10	1.415 35.94	0.859 21.82	0.666 16.92	0.463 11.76
12	1.384 35.15	1.031 26.19	0.822 20.88	0.557 14.14
14	1.384 35.15	1.156 29.36	0.907 23.04	0.590 14.99
16	1.384 35.15	1.281 32.54	1.040 26.41	0.713 18.11
18	1.384 35.15	1.391 35.33	1.165 29.59	0.835 22.21
20	1.539 39.09	1.531 38.89	1.285 32.64	1.015 25.78
22	1.539 39.09	1.656 42.06	1.400 35.56	1.015 25.78
24	1.602 40.69	1.777 45.14	1.540 39.12	1.265 32.13

16J

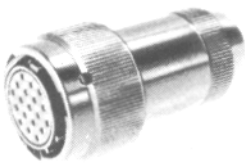

62GB - 16J

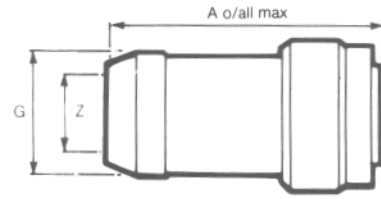
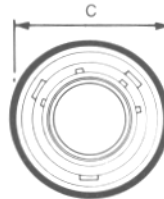

Plug with cable clamp for unscreened jacketed cable. No grommet supplied.

Shell Size	A max	C max	G max	Z min	Z max
08	1.836 46.64	0.750 19.05	0.561 14.25	0.168 4.28	0.230 5.84
10	1.836 46.64	0.859 21.82	0.686 17.43	0.205 5.21	0.312 7.93
12	1.937 49.20	1.031 26.19	0.811 20.60	0.388 8.59	0.442 11.23
14	2.137 54.28	1.156 29.36	0.936 23.78	0.416 10.57	0.539 13.69
16	2.337 59.36	1.281 32.54	1.061 26.95	0.550 13.97	0.616 15.65
18	2.537 64.45	1.391 35.33	1.186 30.13	0.600 15.24	0.672 17.07
20	2.758 70.05	1.531 38.89	1.311 33.30	0.635 16.13	0.747 18.98
22	2.958 75.13	1.656 42.06	1.436 36.75	0.670 17.02	0.846 21.49
24	3.002 76.25	1.777 45.14	1.561 39.65	0.740 18.80	0.894 22.71

Plugs

5039



62GB-5039-10

SD/C 235 155 - X
SD/C 235 156 - X

Low profile, solder termination plug with 90° screened cable outlet.

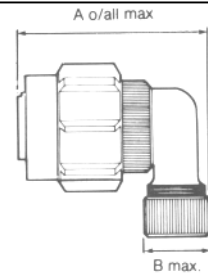
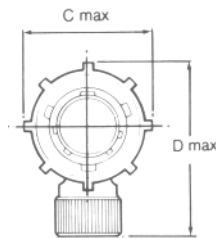

Shell Size	A max	B max	C max	D max
10	1.473 37.41	0.500 12.70	0.980 24.89	1.500 38.10

5055



62GB-5055-10

SD/2 235 193 - X

Low profile solder termination plug with size 12 90° screened cable outlet.

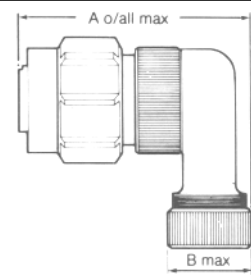
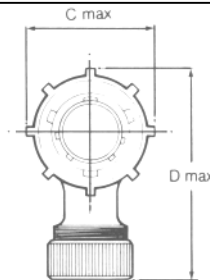

Shell Size	A max	B max	C max	D max
10	1.800 45.72	0.655 16.64	0.980 24.89	1.800 45.72

5056



62GB-5056-10

Audio plug with solder termination

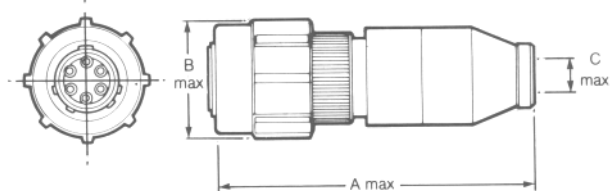

Shell Size	A max	B max	C max
10	2.375 60.33	0.979 / 0.969 24.87 / 24.61	0.310 7.87

Plugs

5074

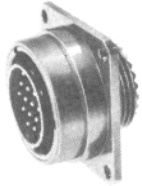

62GB-5074

Flange mounting push/pull plug with threaded shell to accept standard cable accessories.

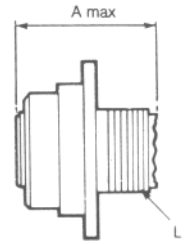
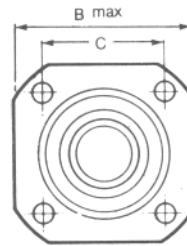

Shell Size	A max	B max	C	L
10	0.912 23.17	1.125 28.57	0.866 22.00	9/16 - 24 NEF
12	0.912 23.17	1.218 30.93	0.969 24.61	9/16 - 24 NEF
14	0.912 23.17	1.312 33.32	1.062 26.97	9/16 - 24 NEF

Insert Orientations

For M I L-C-26482 and for replacement purposes in BS9522 FOO 17

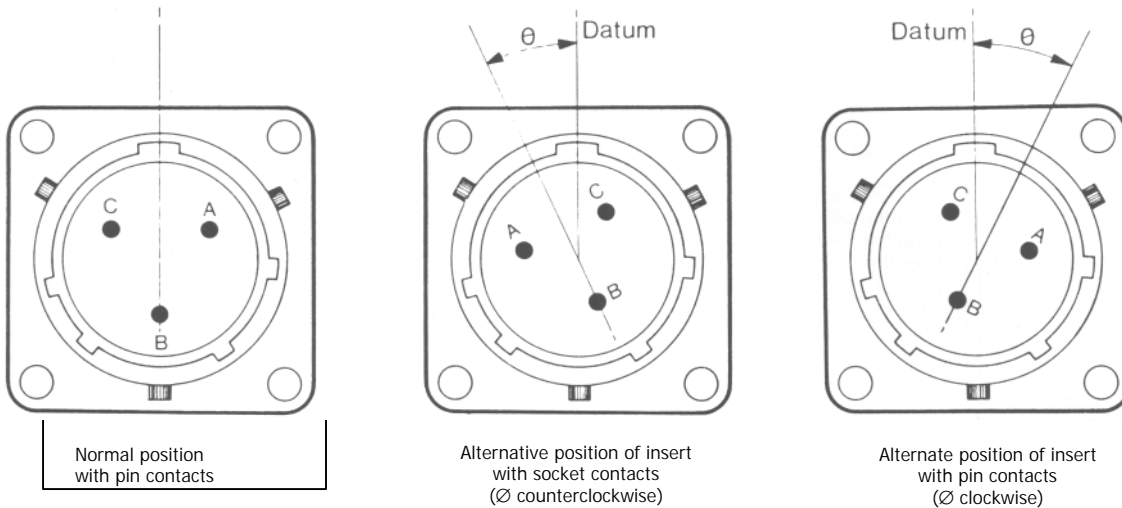

Each diagram shows mating face of insert.

Insert Arrangement	Normal	Orientation \emptyset (degrees)			
		W	X	Y	Z
8-2	0	58	122	-	-
8-3	0	60	210	-	-
8-33	0	90	-	-	-
8-4	0	45	-	-	-
8-98	0	-	-	-	-
10-2	0	-	-	-	-
10-6	0	90	-	-	-
10-7	0	-	-	-	-
12-3	0	-	-	180	-
12-10	0	60	155	270	295
14-5	0	40	92	184	273
14-12	0	43	90	-	-
14-15	0	17	110	155	234
14-19	0	30	165	315	-
16-18	0	54	152	180	331
16-23	0	158	270	-	-
16-26	0	60	-	275	338
18-11	0	62	119	241	340
18-32	0	85	138	222	265
20-16	0	238	318	333	347
20-41	0	45	126	225	-
22-21	0	16	135	175	349
22-55	0	30	142	226	314
24-61	0	90	180	270	324

Key/Keyway Orientations

For BS9522 F0017

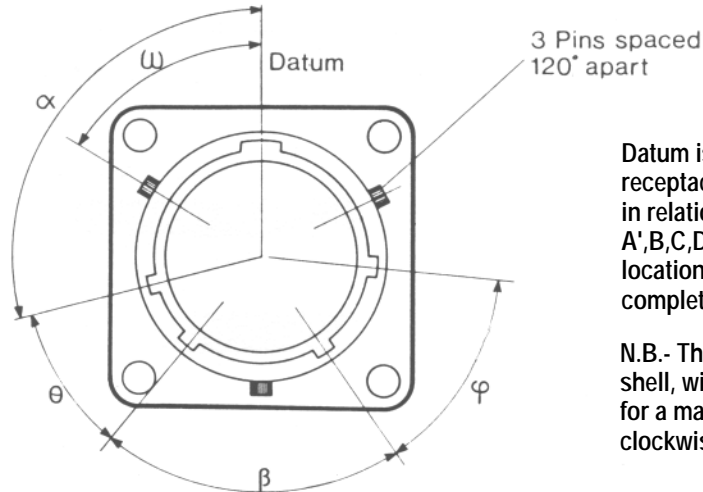

Datum is always taken from major key or keyway. In receptacles the major keyway always remains fixed in relation to the mounting flange. For the A',B,C,D',E and F orientations, the three bayonet locations and associated minor keyways are rotated complete, in accordance with the table below.

N.B.- The accompanying diagram shows a receptacle shell, with keyways. Corresponding key orientations for a mating plug shell are therefore always clockwise.

Shell Size	Values for ω (degrees)							Values for θ (degrees)						Values for β (degrees)							
	N	A*	B	C	D*	E	F	N	A*	B	C	D*	E	F	N	A*	B	C	D*	E	F
8	105	92	-	-	118	118	82	35	35	-	-	35	30	50	75	75'	-	-	75	100	75
10	105	95	85	125	115	115	85	35	35	35	35	35	30	50	75	75	75	75	75	100	75
12	105	97	89	121	113	115	85	35	35	35	35	35	30	50	75	75	75	75	75	100	75
14	105	98	91	119	112	75	120	35	35	35	35	35	30	50	75	75	75	75	75	100	75
16	105	99	93	117	111	75	120	35	35	35	35	35	30	50	75	75	75	75	75	100	75
18	105	100	95	115	110	75	120	35	35	35	35	35	30	50	75	75	75	75	75	100	75
20	105	100	95	115	110	75	120	35	35	35	35	35	30	50	75	75	75	75	75	100	75
22	105	101	97	113	109	75	120	35	35	35	35	35	30	50	75	75	75	100	75	75	75
24	105	101	97	113	109	75	120	35	35	35	35	35	30	50	75	75	75	75	75	100	75

Shell Size	Values for φ (degrees) Orientation							Values for ω (degrees) Orientation						
	N	A*	B	C	D*	E	F	N	A*	B	C	D*	E	F
8	50	50	50	50	50	30	45	60	47	-	-	73	73	47
10	50	50	50	50	50	30	45	60	50	40	80	70	70	50
12	50	50	50	50	50	30	45	60	52	44	76	68	70	50
14	50	50	50	50	50	30	35	60	53	46	74	67	30	75
16	50	50	50	50	50	30	35	60	54	48	72	66	30	75
18	50	50	50	50	50	30	35	60	55	50	70	65	30	75
20	50	50	50	50	50	30	35	60	55	50	70	65	30	75
22	50	50	50	50	50	30	35	60	56	52	68	64	30	75
24	50	50	50	50	50	30	35	60	56	52	68	64	30	75

* now inactive for new designs but available for replacement purposes. Superseded in BS9522 F0017 by orientations E and F.

62 GB- Series Receptacles

CE-2Ra

Miniature Bayonet Lock Connectors
Complies with MIL-C-26482

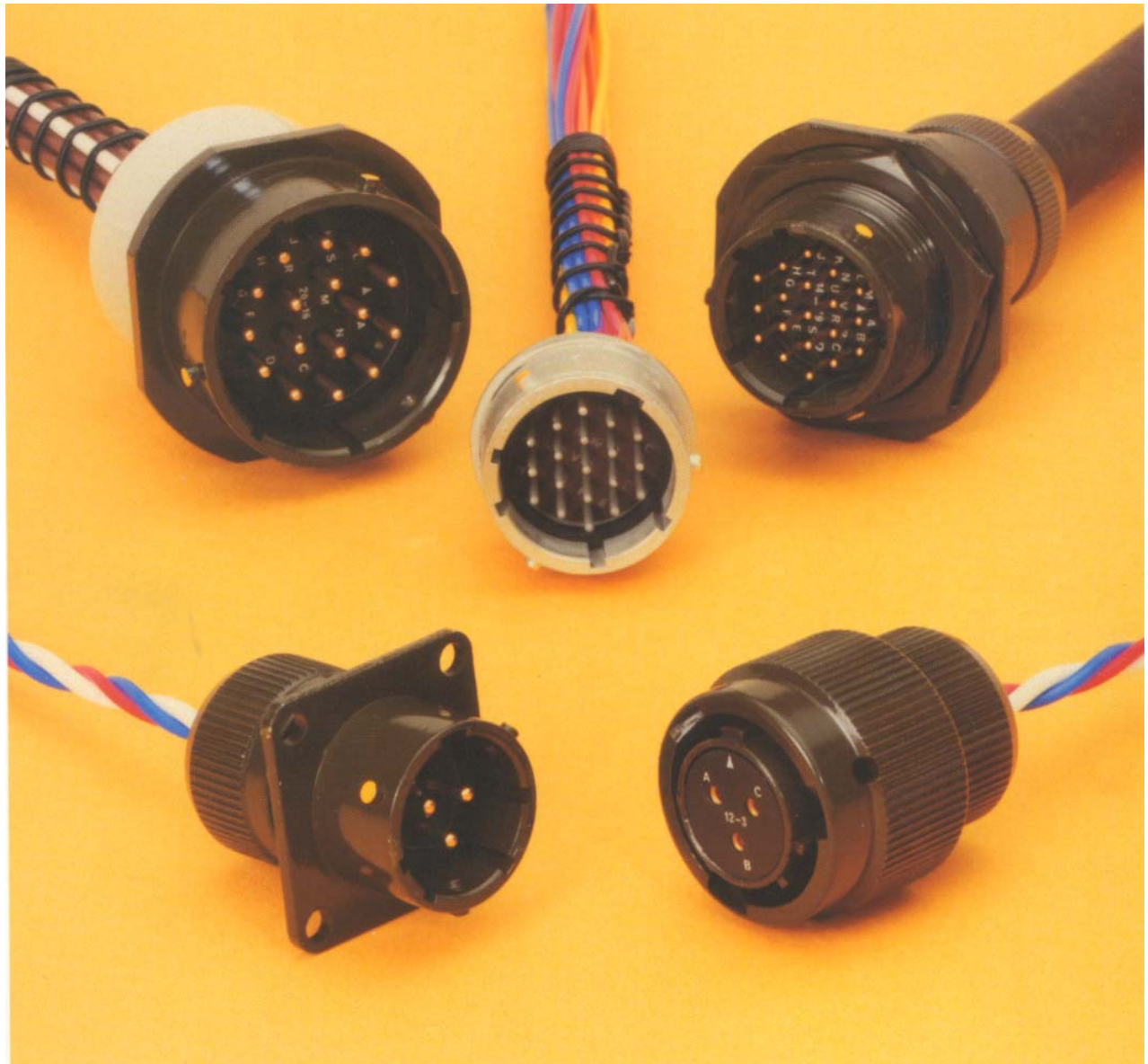

This miniature bayonet lock connector series offers designers important features not found in any other range of connectors.

They are developed and manufactured entirely in the U.K. by AMPHENOL Ltd., and have full qualification approval to British Standards Specification BS 9522 F0017 and British Defence Specification DEF STAN 59-35 (Part 3) Sec. 7.

This catalogue to be used in conjunction with Catalogues:
CE-2Pa – 62GB Series Plugs
CE-2Aa – 62GB Series Accessories

Amphenol

62GB and Pattern 608 New Planforms

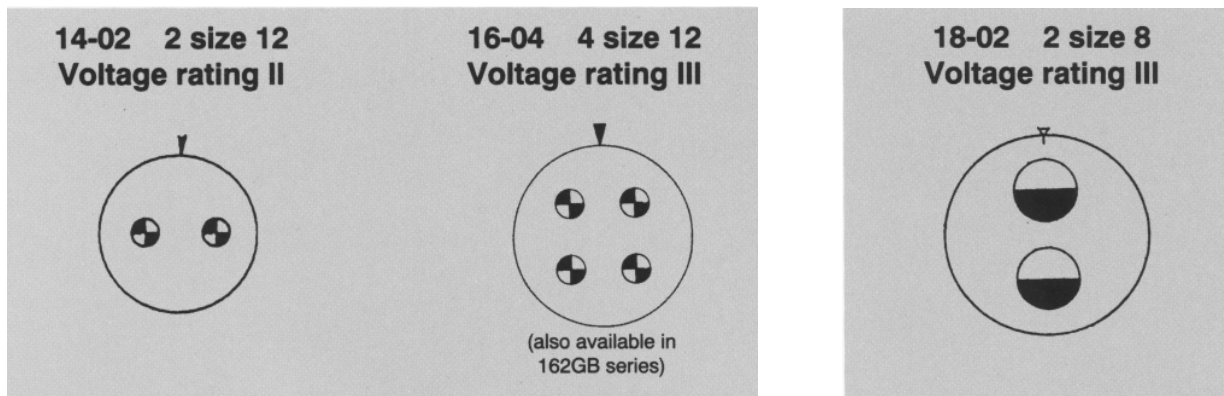

Current:

- (a) Maximum current per individual contact (in isolation)* at ambient temperature of 85°C
Contact size 12: 23 A
- (b) Maximum current per contact through all contacts simultaneously at an ambient temperature of 85°C
Contact size 12: 20 A

Current:

- (a) Maximum current per individual contact (in isolation)* at ambient temperature of 85°C
Contact size 8: 45 A
- (b) Maximum current per contact through all contacts simultaneously at an ambient temperature of 85°C
Contact size 8: 40 A

	Sea level 1013 mbar †			8500m (27,900ft) 320 mbar			21,340m (70,000ft) 44 mbar		
	I	II	III	I	II	III	I	II	III
Voltage rating Working voltages ** (nominal) d.c. or a.c. peak	700	1200	1500	550	650	800	330	380	450
Voltage proof d.c. or a.c. peak	2100	3000	3000	1100	1300	1300	660	760	750

* i.e. when only one contact per connector is electrically loaded.
 † 1 mbar=10² N/m²=100 Pa
 ** Establishment of electrical safety factors is the responsibility of the user

CONTENTS	Page
Amphenol 62GB Solder Connectors	4
Schedule of Tests	5-6
Connector Styles Available	7
Insert Availability	9-10
Ordering 62GB Series Connectors	11-12
Box Mounting Receptacles - Table of Styles	13-14
Box Mounting Receptacles	15-19
Single Hole Fixing Receptacles - Table of Styles	20-22
Single Hole Fixing Receptacles	23-30
Cable Mounting Receptacles - Table of Styles	31
Cable Mounting Receptacles	32-34
Insert Orientations	35
Key/Keyway Orientations	36

This catalogue to be used in conjunction with Catalogues:
CE-2Pa – 62GB Series Receptacles
CE-2Aa – 62GB Series Accessories

Amphenol® 62GB solder connectors

This miniature bayonet lock connector series offers designers important features not found in any other range of connectors. The range has full qualification approval to British Standards Specification BS 9522 FOO 17 and British Defence Specification DEF STAN 59-35 (Part 3) Sec. 7.

62GB Series connectors - developed and manufactured entirely in the United Kingdom by Amphenol Limited. They are the first and only British connectors to have achieved this. A doubly strong position which Amphenol are well geared to handle. The manufacturing facilities of the Whitstable plant have been cited as exemplary in Europe. Certainly the layout is extensive and extremely efficient; safety awards have been attained every time returns have been submitted to the British Safety Council.

62GB Series connectors have been well established with Government authorities on an international scale and users can be found in Sweden, Denmark, Norway, Finland, Germany, Spain, Holland, India, Canada and Italy.

Derating

Connectors must be derated under the following operating conditions:

1. At elevated ambient temperatures, the current ratings are reduced so that total maximum hot spot temperature of 125°C is not exceeded.
2. At high altitudes, revised voltage ratings become effective as shown on page 7.
3. When connectors to different specifications are intermated (e.g. BS 9522 FOO 17 and MIL-C-26482), the combination must not be operated under conditions more severe than the less stringent clause of either specification.

Amphenol 62GB connectors are designed to meet the most stringent requirements of both specifications.

Military Specifications

British Standards Specification BS 9522 FOO 17 closely corresponds to the United States Military Specification MIL-C-26482 solder terminations. Certain differences exist between the schedules which can be seen on pages 2 and 3.

Approved gauges are used to check interchangeability of 62GB series with other connectors manufactured to BS 9522 FOO 17 or MIL-C-26482.

Basic Construction

62GB Series can be supplied in brass or stainless steel.

The normal shell finish used, which has a high resistance to corrosion, is zinc cobalt olive drab. Other finishes may be supplied to special order, such as cadmium plate which is available by adding deviation (714) to the end of part number.

Inserts are of polychloroprene rubber compounded to an Amphenol specification. Operating temperature range is -55°C to 125°C, and the connectors have gold-plated contacts designed for soldered connections. Configurations for size 20 contacts range between 2 contacts in the size 8 12.7mm (0.5in diameter) shell up to a maximum of 61 contacts in the size 2436.1 mm (1.5in diameter) shell. Intermediate sizes, and contact data for heavier current ratings are shown in the insert availability chart on page 6 and 7.

Hermetic connectors with glass sealed dielectric are manufactured with mild steel shells and nickel iron contacts plated tin over copper.

* Other finishes are available on request.

Protection Against Mis-Mating or Cross-Plugging

In BS 9522 FOO 17 positive shell-to-shell keying is provided with keys and keyways in a choice of either the normal (N) or any of the four preferred alternate positions: B, C, E and F. This prevents mismating between shells of different orientations and overcomes the difficulties associated with rotated inserts and a standard key-keyway orientation. In the latter system, damage to the inserts or contacts can result if excessive force is used to engage non-mating pairs.

Rotated inserts are, however, permissible in BS 9522 FOO 17 connectors if required to mate with or replace units to MIL-C-26482 mounted in existing equipment. Connectors have normal orientations manufactured to BS 9522 FOO 17 or MIL-C-26482 are fully intermateable as also are connectors with inserts in positions W, X, Y or Z.

Schedule of Tests Required for Qualification Approval

Tests	Brief Description
Visual Examination	
Dimensions, outline mass(including contacts) Compatability Gauging procedure	
Polarization	
Engaging and separating force, connector	Engagement max: 0,90 Nm (8.0 lbf.in.) to 4,97 Nm (44 lbf.in.) according to shell size. Separation min: 0,22 Nm (2.0 lbf.in.) to 1,58 Nm (14.0 lbf.in.) according to shell size.
Contact Holding Force	0,21 N (0.047 lbf) min.size 20 0,56 N (0.126 lbf)min. size 16
Sealing (air pressure)	Max leakage 28,53 uNm/s (1 cm ³ /h), 1 bar (14.5 p.s.i.) differential.
Sealing Hermetic	Hermetic receptacles have a max leak of 0.1 micron cubic foot per hour (1 x 10 ⁻⁶ Cm ³ /s)
Contact Resistance	5 milliohms max.
Housing (Shell) Continuity	200 milliohms max. 5 milliohms max. grounding spring styles.
Insulation Resistance	5,000 Megaohms at 500 - 50 V d.c.
Voltage Proof	See page 7. Duration 1 minute
Soldering	As BS 9520: 1974, Clause 1.2.6.6, Method 2.
Bumping	As BS 9520: 1974, Clause 1.2.6.1. 4,000 -10 bumps / 390m / s ² (40 gn).
Vibration	As BS 9520: 1974, Clause 1.2.6.2.1. Procedure A. 10 Hz to 5000 Hz, 0.75 mm / 10 gn.
Shock	As BS 9520: 1974, Clause 1.2.6.3. 981 m/s ² (100 g n).
Acceleration (Steady State)	As BS 9520: 1974, Clause 1.2.6.4. 490 m/s ² (50 gn).
Rapid Change of Temperature	As BS 9520: 1974, Clause 1.2.6.7. -550 C to - 1250 C.
Climatic Sequence	As BS 9520: 1974, Clause 1.2.6.11. Severity 55/125/56.
Flammability	As BS 9520: 1974, Clause 1.2.6.8. Direct flame applied, duration 1 minute.
Damp Heat (Steady State)	As BS 9520: 1974, Clause 1.2.6.14. Severity 56 days.

Schedule of Tests Required for Qualification Approval

Tests	Brief Description
Immersion (at low air pressure)	3 cycles at 30 mins each cycle, total immersion in water at pressure 44 m bar.
Mechanical Endurance	500 operations minimum
High Temperature Endurance	Long term: 1,000 hrs. at 85°C ambient carrying the specified current. Short term: 250 hrs at 125°C, no current.
Mould Growth	As BS 9520: 1983, Clause 1.2.6.16 28 days duration.
Salt Mist	As BS 9520: 1983, Clause 1.2.6.17. Severity 1.
Dust	As BS 9520: 1983, Clause 1.2.6.18 Exposure 30 minutes.
Robustness of Terminations	44,5 N (101bf) size 16 22,2 N (5 lbf) size 20
Contact Retention (in insert)	67,0 N (15 lbf) min. size 20 112,0 N (25 lbf) min. size 16
Insert Retention (in shell)	517 KN1m2 (751bf/in2) min.
Test Prod Damage	Moment: 0,056 Nm (0.5 lbf in) size 20 0,225 Nm (2 lbf in) size 16
Impact	Five impacts, drop height 1 m (3ft.3 in.).
Grounding Spring Holding Force Plugs with grounding springs only.	1,17 N (0.263 lbf) to 2,74 N (0.616 lbf) according to size.
Fluid Resistance	Immersion in 4 solvents and 9 fluids including aircraft fuels, lubricating oils and hydraulic fluids.
Compass Safe Distance	As BS 9520: 1974, Clause 1.2.5.11. 127 mm (5.0 in) min.

Connector Styles Available

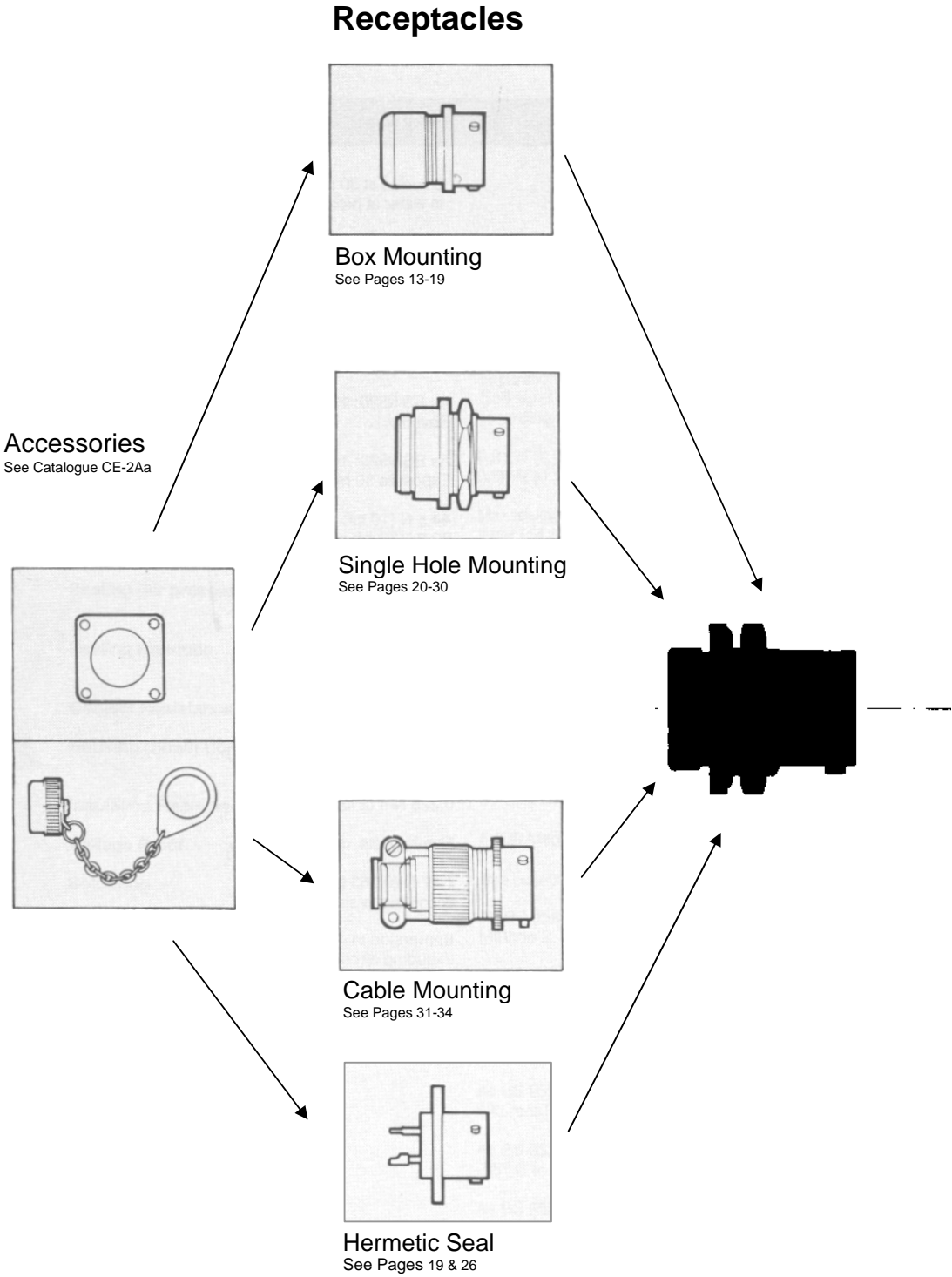

Insert Availability

8	10	12	14	16	18	20
8-2* 	10-6 	12-10 	14-12† 	16-23* 	18-32 	20-41
8-3* 	10-7 		14-15 	16-26 		
8-33 			14-19 			
8-4* 						
8-98 	10-2 	12-3 	14-5 	16-8 	18-11 	20-16

NOTES

* This insert arrangement is not included in B.S. spec., but is available and listed in MIL-C-26482.

† Due to the arrangement of contacts in the 14-12 insert arrangement it is classified, for current derating, in the shell size range 18-24.

Lettering of inserts shown above corresponds to view of front (mating surface of pin inserts or rear face (cable accessory end) of socket inserts).

KEY ● No 16 size contacts
○ No 20 size contacts

CURRENT RATING

Maximum current per individual contact (in isolation) at a maximum ambient temperature of 85°C: Size 20 contact 7.5A Size 16 contact 13-OA The performance of 62GB Series connectors at all times exceeds the maximum continuous bunched rating of the appropriate size wire, or cable of equivalent temperature rating. This bunched rating is therefore the determining factor. In the case of mixed loadings, the greatest individual load shall be the bunched loading. In any combination of ambient temperature plus temperature rise due to current flow through the contacts, the maximum connector internal hot spot temperature of 125°C must not be exceeded. That is, when only one contact per connector is loaded.

Insert Availability

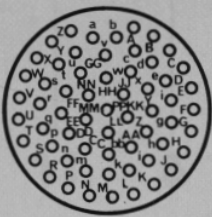
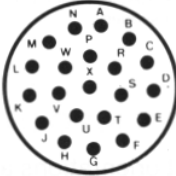
		VOLTAGE RATINGS			
22	24	ALTITUDE	D.C. WORKING VOLTAGE	A.C. WORKING VOLTAGE R.M.S.	PROOF VOLTAGE D.C. OR A.C. PEAK
<p>22-55</p> 	<p>24-61</p> 	<p>Rating 1 Sea level</p> <p>300 mb at 20°C 8,500m (27,800 ft)</p> <p>44 mb at 20°C 20,000m (66,000 ft)</p>	<p>700</p> <p>550</p> <p>330</p>	<p>500</p> <p>390</p> <p>230</p>	<p>2100</p> <p>1100</p> <p>660</p>
<p>22-21</p>  <p>† Available to special order only</p>		<p>Rating 2 Sea level 300 mb at 20°C 8,500m (27,800 ft) 44 mb at 20°C 20,000m (66,000 ft)</p>	<p>120</p> <p>650</p> <p>380</p>	<p>850</p> <p>460</p> <p>270</p>	<p>3000</p> <p>1300</p> <p>760</p>

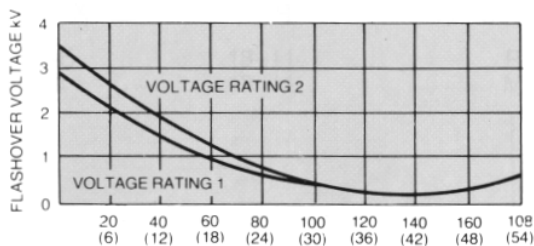

ALTIMETER-THOUSANDS OF FEET (METRES)
Relationship between flashover voltage and altitude for each voltage rating

VOLTAGE RATINGS

Two categories of voltage rating are specified in BS9522 F0017, F0038 and N0001.

Rating 1 (700V d.c. working at sea-level) Applicable to the high contact density inserts shown in the upper section of the insert availability diagram above.

Rating 2 (1200V d.c. working at sea-level) Applicable to the inserts shown in the lower section of the insert availability diagram.

Altitude derating. Information on voltage derating for operation at altitudes above sea-level can be obtained from the flashover voltage altitude curves on the left.

Ordering 62GB Series Connectors

To obtain the specific connector required write down the connector number from the typical example below. Only inserts shown in the availability chart on p. 10&11 can be specified. All connectors are delivered with protective dust covers

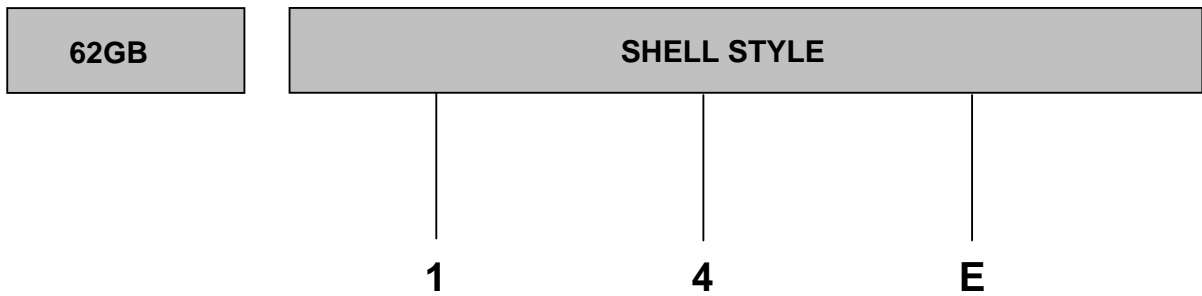

Series designation
 62 GB - Aluminium shell
 62 GB SS -Stainless steel shell*
 62 GB CU - Brass shell*
 *consult factory for availability
 62GB-XXH-Hermetic mild steel shell.

Specification key
 1 - Styles originally specified in MIL-C-26482
 5 - Styles exclusive to BS9522 F0017

Shell style
 0 - Receptacle wall mounting
 1 - Receptacle cable mounting
 2 - Receptacle box mounting
 3 - Receptacle, solder flange mounting
 4 - Receptacle, internally threaded with cable accessories as illustrated, for single hole mounting
 6 - Plug cable mounting
 7- Receptacle, plain shell, single hole mounting

Environmental code
 A - Plain shell, exposed solder buckets. No grommet
 E - Insert seal and grommet seal with grommet nut (excluding 12E which has plain shell and no grommet or nut)
 F - As (E) but grommet nut has integral strain relief clamp
 H - Hermetic seal no cable accessories
 J - As (E) but with resilient gland seal and nut for unscreened jacketed cable. No grommet supplied. See pp. 26-27 for accessory to accept screened jacketed cable.
 P - Potting construction complete with potting mould
 T - Exposed solder buckets. Threaded shell for cable accessories

HOW TO ORDER FROM MS CONNECTOR NUMBERS

Connector numbers in the AMPHENOL and MS numbering systems. Only alternative insert orientations are specified in MIL-C-26482 which does not include alternative key/keyway orientations.

MS31	-	14	E	18 -11	P	X
62GB	-	14	E	18 -11	P	X

Ordering 62GB Series Connectors

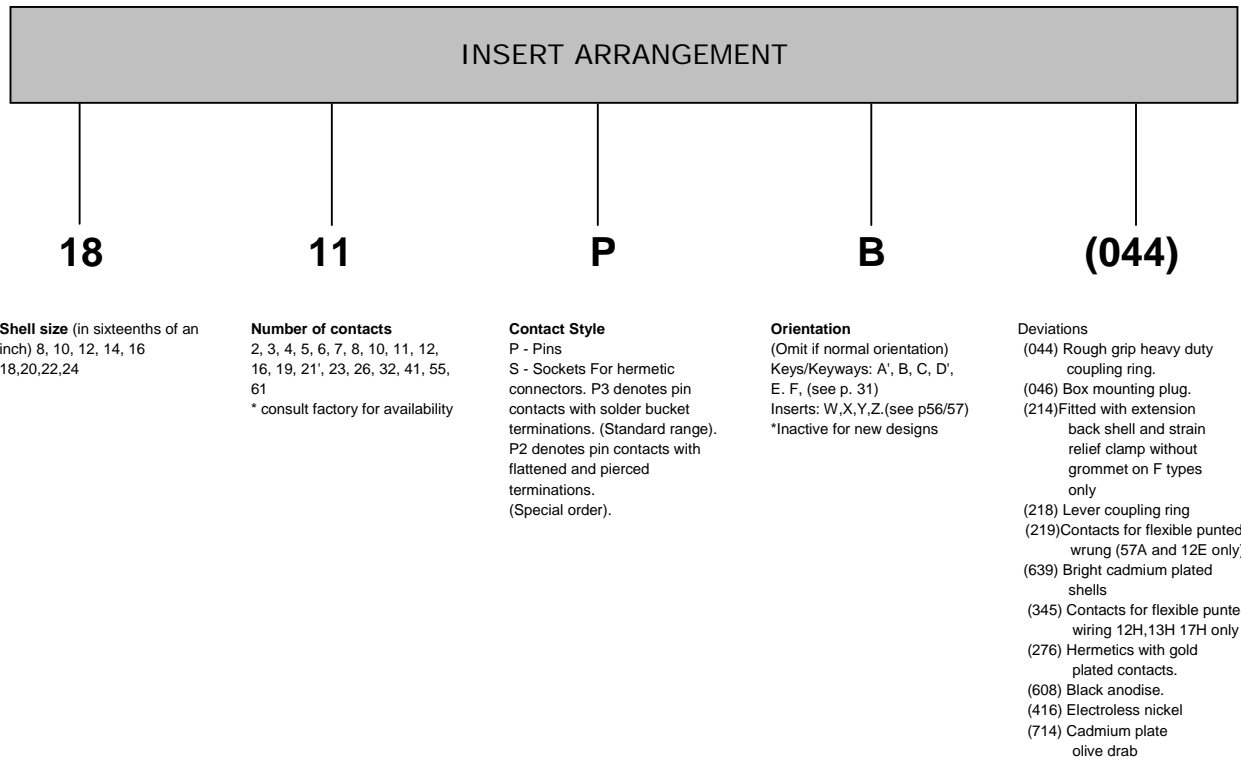

HOW TO ORDER FROM B.S. CONNECTOR NUMBERS

Select the connector style by reference to BS9522 F0017 using the code below for identification. Note that the B.S. Specification includes only certain connectors from the table of styles as shown on pp. 8 & 9. Alternative key/keyway orientations are preferred in the BS9522 F0017 Specification to prevent mis-mating. However, rotated inserts are permissible where connectors are required to mate with or replace items to MIL-C-26482 on existing equipment.

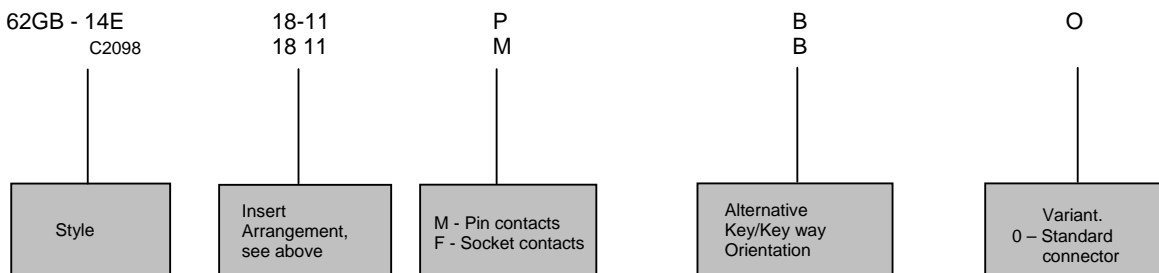

Box Mounting Receptacles

Table of Styles

Page No.

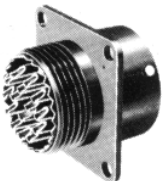
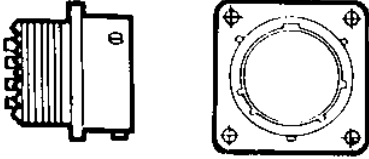
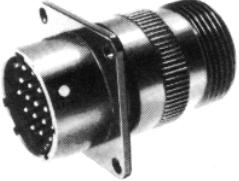
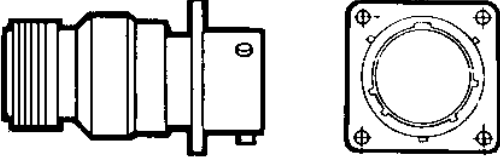
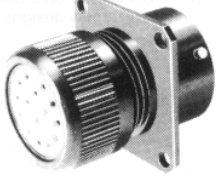
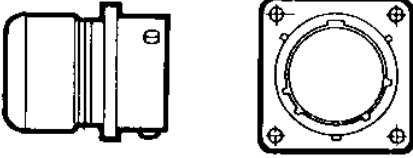
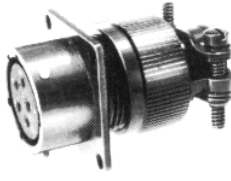
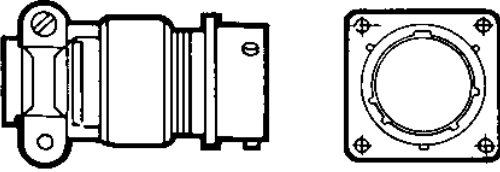
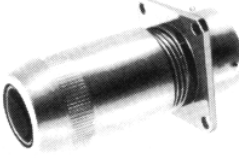
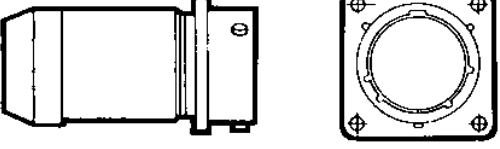
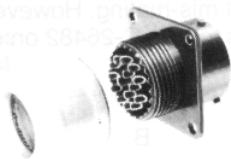
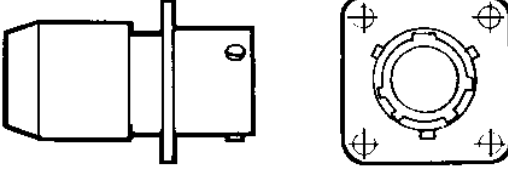
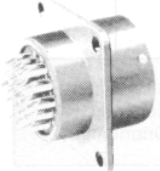
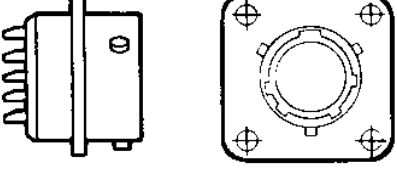
62GB-50T			15
62GB-10A			15
62GB-10E			16
62GB-10F			16
62GB-10J			17
62GB-10P			17
62GB-12E			18

Box Mounting Receptacles

Table of Styles

Page No.

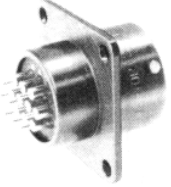
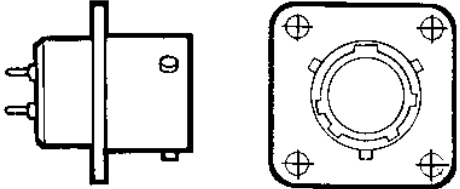
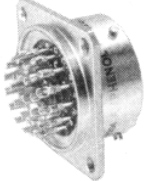
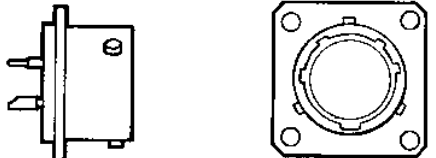
<p>62GB-12E(219)</p>			<p>18</p>
<p>62GB-12H Hermetic Seal</p>			<p>19</p>

Box Mounting Receptacles

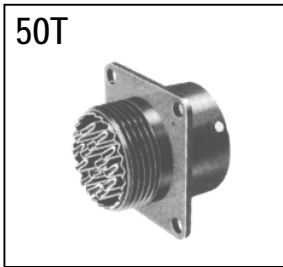
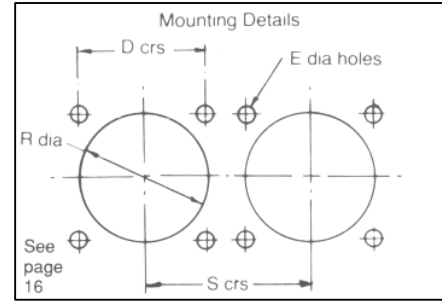

62GB-50T
BS9522-C2096

4-hole flange mounting with threaded shell to accept standard cable accessories.

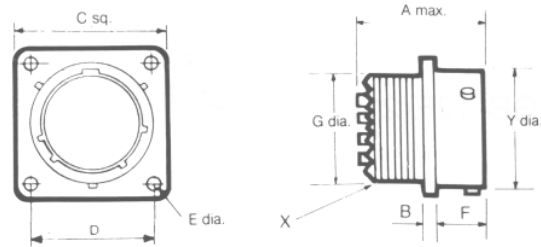

Shell Size	A max	B ± 0.005 (± 0.13)	c max sq.	D TP Sq.	E dia. ± 0.010 (± 0.254)	F ± 0.005 (± 0.13)	G dia max.	Y dia. max.	X Thread
08	0.978	0.062	0.817	0.594	0.120	0.445	0.434	0.473	7/16 – 28 UNEF
	24.84	1.58	20.75	15.09	3.05	11.3	11.02	12.02	
10	0.978	0.062	0.942	0.719	0.120	0.445	0.558	0.590	9/16 – 24 NEF
	24.84	1.58	23.93	18.26	3.05	11.3	14.17	14.99	
12	0.978	0.062	1.036	0.812	0.120	0.445	0.683	0.750	11/16 – 24 NEF
	24.84	1.58	26.32	20.63	3.05	11.3	17.35	19.05	
14	0.978	0.062	1.130	0.906	0.120	0.445	0.808	0.875	13/16 – 20 UNEF
	24.84	1.58	28.70	23.10	3.05	11.3	20.52	22.23	
16	0.978	0.062	1.223	0.969	0.120	0.445	0.933	1.000	15/16 – 20 UNEF
	24.84	1.58	31.07	24.61	3.05	11.3	23.7	25.4	
18	0.978	0.062	1.317	1.062	0.120	0.445	1.057	1.125	1.1/16 – 18 NEF
	24.84	1.58	33.45	26.58	3.05	11.3	26.85	28.58	
20	1.048	0.080	1.442	1.156	0.120	0.555	1.182	1.250	1.3/16 – 18 NEF
	26.62	2.03	36.63	29.36	3.05	14.10	30.02	31.75	
22	1.048	0.080	1.567	1.250	0.120	0.555	1.307	1.375	1.5/16 – 18 NEF
	26.62	2.03	39.80	31.75	3.05	14.10	33.20	34.93	
24	1.048	0.080	1.692	1.375	0.147	0.590	1.432	1.500	1.7/16 – 18 NEF
	26.62	2.03	42.98	34.93	3.73	14.99	36.37	38.1	

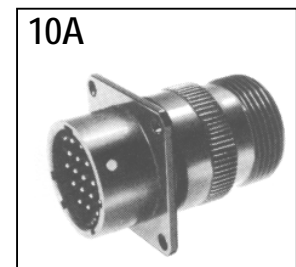

62GB-10A

4-Hole flange mounting with general duty back shell. No grommet supplied.

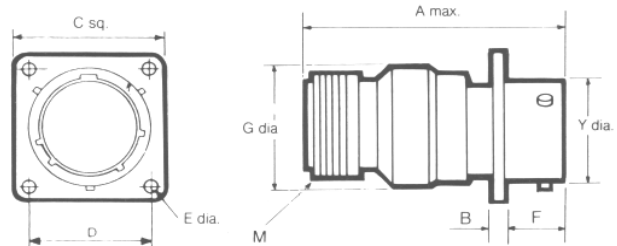

Shell Size	A max.	B ± 0.005 (± 0.13)	C Max. sq.	D TP Sq.	E ± 0.010 (± 0.254)	F ± 0.005 (± 0.13)	G dia max.	Y dia. max.	M
08	1.624	0.062	0.817	0.594	0.120	0.445	0.561	0.473	1/2 - 28 UNEF
	41.25	1.58	20.75	15.09	3.05	11.3	14.25	12.02	
10	1.624	0.062	0.942	0.719	0.120	0.445	0.686	0.590	5/8 - 24 NEF
	41.25	1.58	23.93	18.26	3.05	11.3	17.43	14.99	
12	1.624	0.062	1.036	0.812	0.120	0.445	0.811	0.750	3/4 - 20 UNEF
	41.25	1.58	26.32	20.63	3.05	11.3	20.60	19.05	
14	1.624	0.062	1.130	0.906	0.120	0.445	0.936	0.875	7/8 - 20 UNEF
	41.25	1.58	28.70	23.10	3.05	11.3	23.78	22.23	
16	1.624	0.062	1.223	0.969	0.120	0.445	1.061	1.000	1 - 20 UNEF
	41.25	1.58	31.07	24.61	3.05	11.3	26.98	25.4	
18	1.624	0.062	1.317	1.062	0.120	0.445	1.186	1.125	1.3/16 - 18 NEF
	41.25	1.58	33.45	26.58	3.05	11.3	30.12	28.58	
20	1.687	0.080	1.442	1.156	0.120	0.555	1.311	1.250	1.3/16 - 18 NEF
	42.85	2.03	36.63	29.36	3.05	14.10	33.30	31.75	
22	1.687	0.080	1.567	1.250	0.120	0.555	1.436	1.375	1.7/16 - 18 NEF
	42.85	2.03	39.80	31.75	3.05	14.10	36.47	34.93	
24	1.730	0.080	1.692	1.375	0.147	0.590	1.561	1.500	1.7/16 - 18 NEF
	43.94	2.03	42.98	34.93	3.73	14.99	39.65	38.1	

Box Mounting Receptacles

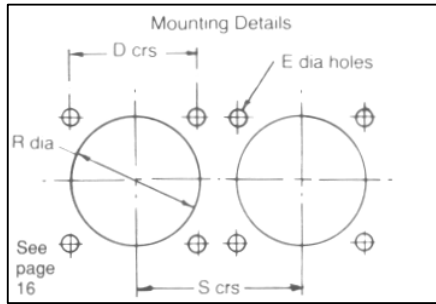

62GB-10E
MIL-C-26482 MS3110E

4-hole flange mounting with grommet and grommet nut

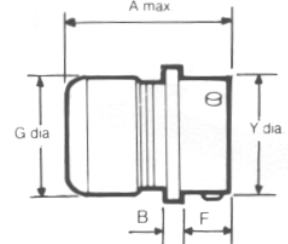
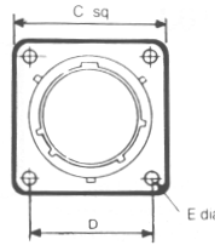

Shell Size	A max	B ± 0.005 (± 0.13)	C max sq.	D TP Sq.	E ± 0.010 (± 0.254)	F ± 0.005 (± 0.13)	G dia max	V dia. max
08	1.281	0.062	0.817	0.594	0.120	0.445	0.561	0.473
	32.54	1.58	20.75	15.09	3.05	11.3	14.25	12.02
10	1.281	0.062	0.942	0.719	0.120	0.445	0.686	0.590
	32.54	1.58	23.93	18.26	3.05	11.3	17.43	14.99
12	1.281	0.062	1.036	0.812	0.120	0.445	0.811	0.750
	32.54	1.58	26.32	20.63	3.05	11.3	20.60	19.05
14	1.281	0.062	1.130	0.906	0.120	0.445	0.936	0.875
	32.54	1.58	28.70	23.10	3.05	11.3	23.78	22.23
16	1.281	0.062	1.223	0.969	0.120	0.445	1.061	1.000
	32.54	1.58	31.07	24.61	3.05	11.3	26.98	25.4
18	1.281	0.062	1.317	1.062	0.120	0.445	1.186	1.125
	32.54	1.58	33.45	26.58	3.05	11.3	30.12	28.58
20	1.383	0.080	1.442	1.156	0.120	0.555	1.311	1.250
	35.13	2.03	36.63	29.36	3.05	14.10	33.30	31.75
22	1.383	0.080	1.567	1.250	0.120	0.555	1.436	1.375
	35.13	2.03	39.80	31.75	3.05	14.10	36.47	34.93
24	1.383	0.080	1.692	1.375	0.147	0.590	1.561	1.500
	35.13	2.03	42.98	34.93	3.74	14.99	39.65	38.1



62GB-10F
MIL-C-26482 MS31 10F

4-hole flange mounting with grommet and grommet nut fitted with integral strain relief clamp

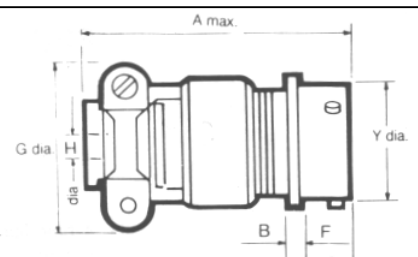
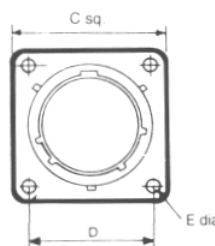

Shell Size	A max.	B ± 0.005 (± 0.13)	C max. sq.	D TP Sq.	E ± 0.010 (± 0.254)	F ± 0.005 (± 0.13)	G dia max.	H ± 0.005 (± 0.13)	Y dia. max.
08	1.762	0.062	0.817	0.594	0.120	0.445	0.828	0.156	0.473
	44.76	1.58	20.75	15.09	3.05	11.3	21.03	3.96	12.01
10	1.762	0.062	0.942	0.719	0.120	0.445	0.891	0.188	0.590
	44.76	1.58	23.92	18.26	3.05	11.3	22.63	4.78	14.99
12	1.762	0.062	1.036	0.812	0.120	0.445	1.016	0.312	0.750
	44.76	1.58	26.31	20.63	3.05	11.3	25.81	7.93	19.05
14	1.736	0.062	1.130	0.906	0.120	0.445	1.141	0.375	0.875
	44.10	1.58	28.70	23.10	3.05	11.3	28.98	9.58	22.23
16	1.876	0.062	1.223	0.969	0.120	0.445	1.203	0.500	1.000
	47.65	1.57	31.07	24.61	3.05	11.3	30.56	12.7	25.4
18	1.876	0.062	1.317	1.062	0.120	0.445	1.426	0.625	1.125
	47.65	1.58	33.45	26.58	3.05	11.3	36.22	15.87	28.58
20	2.118	0.080	1.442	1.156	0.120	0.555	1.426	0.625	1.250
	53.80	2.03	36.63	29.36	3.05	14.10	36.22	15.88	31.75
22	2.118	0.080	1.567	1.250	0.120	0.555	1.567	0.750	1.375
	53.80	2.03	39.80	31.75	3.05	14.10	39.80	19.05	34.93
24	2.250	0.080	1.692	1.375	0.147	0.590	1.735	0.800	1.500
	57.15	2.03	42.98	34.93	3.74	14.99	44.07	20.32	38.10

Box Mounting Receptacles

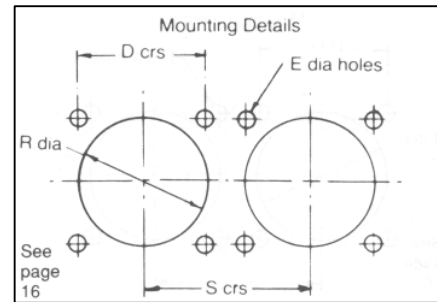

10J

62GB-10J

4-hole flange mounting with clamp for unscreened jacketed cable. No grommet supplied

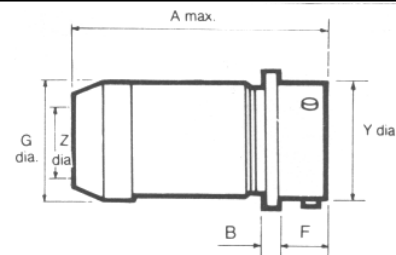
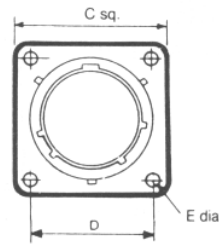

Shell Size	A max	B ± 0.005 (± 0.13)	c max.sq	D TP sq	E ± 0.010 (± 0.254)	F ± 0.005 (± 0.13)	G dia. max.	Y dia. max	Z Cable Entry	
									min closed	max free
08	1.846	0.062	0.817	0.594	0.120	0.445	0.561	0.473	0.168	0.230
	46.89	1.58	20.75	15.09	3.05	11.3	14.25	12.02	4.28	5.84
10	1.846	0.062	0.942	0.719	0.120	0.445	0.686	0.590	0.205	0.312
	46.89	1.58	23.93	18.26	3.05	11.3	17.43	14.99	5.21	7.93
12	1.947	0.062	1.036	0.812	0.120	0.445	0.811	0.750	0.338	0.442
	49.45	1.58	26.32	20.63	3.05	11.3	20.60	19.05	8.59	11.23
14	2.147	0.062	1.130	0.906	0.120	0.445	0.936	0.875	0.416	0.539
	54.54	1.58	28.70	23.10	3.05	11.3	23.78	22.23	10.57	13.69
16	2.347	0.062	1.223	0.969	0.120	0.445	1.061	1.000	0.550	0.616
	59.61	1.575	31.07	24.61	3.05	11.3	26.96	25.4	13.97	15.65
18	2.547	0.062	1.317	1.062	0.120	0.445	1.186	1.125	0.600	0.672
	64.70	1.575	33.45	26.58	3.05	11.3	30.12	28.58	15.24	17.07
20	2.831	0.080	1.442	1.156	0.120	0.555	1.311	1.250	0.635	0.747
	71.91	2.03	36.63	29.36	3.05	14.10	33.30	31.75	16.13	18.98
22	3.031	0.080	1.567	1.250	0.120	0.555	1.436	1.375	0.670	0.846
	76.99	2.03	39.80	31.75	3.05	14.10	36.47	34.93	17.02	21.49
24	3.074	0.080	1.692	1.375	0.147	0.590	1.561	1.500	0.740	0.894
	78.08	2.03	42.98	34.93	3.73	14.99	39.65	38.1	18.80	22.71

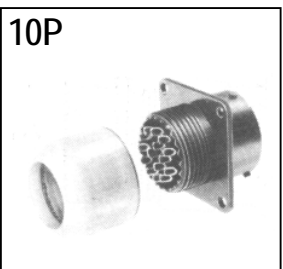

10P

62GB-10P

4-hole flange mounting for potting

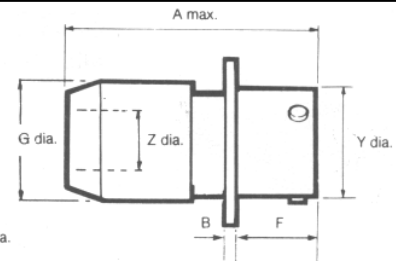
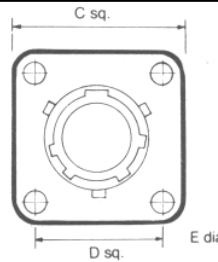

Shell Size	A max	B ± 0.005 (± 0.13)	c max.sq.	D TP sq	E ± 0.010 (± 0.254)	F ± 0.005 (± 0.13)	G dia. max	Y dia. max	Z dia. min
									Z dia. min
08	1.453	0.062	0.817	0.594	0.120	0.445	0.572	0.473	0.260
	36.91	1.575	20.75	15.09	3.05	11.3	14.53	12.02	6.60
10	1.453	0.062	0.942	0.179	0.120	0.445	0.666	0.590	0.463
	36.91	1.58	23.93	18.26	3.05	11.3	16.92	14.99	11.76
12	1.453	0.062	1.036	0.812	0.120	0.445	0.822	0.750	0.577
	36.91	1.58	26.32	20.63	3.05	11.3	20.88	19.05	14.15
14	1.453	0.062	1.130	0.906	0.120	0.445	0.907	0.875	0.590
	36.91	1.58	28.70	23.10	3.05	11.3	23.04	22.23	14.99
16	1.453	0.062	1.223	0.969	0.120	0.445	1.040	1.000	0.713
	36.91	1.58	31.07	24.61	3.05	11.3	26.42	25.40	18.11
18	1.453	0.062	1.317	1.062	0.120	0.445	1.165	1.125	0.835
	36.91	1.58	33.45	26.58	3.05	11.3	29.60	28.58	22.21
20	1.672	0.080	1.442	1.156	0.120	0.555	1.285	1.250	1.015
	42.47	2.03	36.63	29.36	3.05	14.10	32.64	31.75	25.78
22	1.672	0.080	1.567	1.250	0.120	0.555	1.400	1.375	1.015
	42.47	2.03	39.80	31.75	3.05	14.10	35.56	34.93	25.78
24	1.734	0.080	0.692	1.375	0.147	0.590	1.540	1.500	1.265
	44.05	2.03	42.98	34.93	3.74	14.99	39.12	38.10	32.13

Box Mounting Receptacles

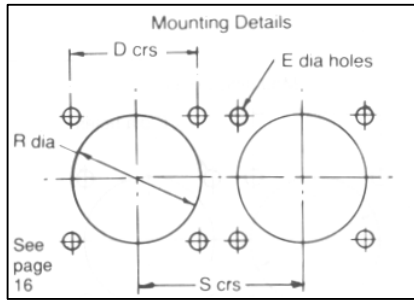

12E



62GB-12E

BS9522 - F0017 - C2097
MIL-C-26482 MS3112E

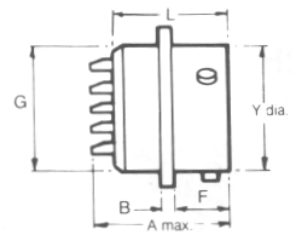
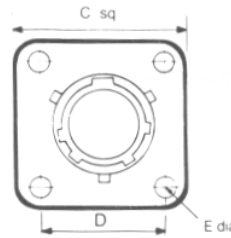

Shell Size	A max	8 ± 0.005 (± 0.13)	C max sq.	D TP sq.	E ± 0.010 (± 0.254)	F ± 0.005 (± 0.13)	G dia. max.	L	V dia. max.
08	0.978	0.062	0.817	0.594	0.120	0.445	0.434	0.800	0.473
	24.84	1.58	20.75	15.09	3.05	11.3	11.02	20.32	12.02
10	0.978	0.062	0.942	0.719	0.120	0.445	0.558	0.800	0.590
	24.84	1.58	23.93	18.26	3.05	11.3	14.17	20.32	14.99
12	0.978	0.062	1.036	0.812	0.120	0.445	0.683	0.800	0.750
	24.84	1.58	26.32	20.63	3.05	11.3	17.35	20.32	19.05
14	0.978	0.062	1.130	0.906	0.120	0.445	0.808	0.800	0.875
	24.84	1.58	28.70	23.10	3.05	11.3	20.52	20.32	22.23
16	0.978	0.062	1.223	0.969	0.120	0.445	0.933	0.800	1.000
	24.84	1.58	31.07	24.61	3.05	11.3	23.70	20.32	25.4
18	0.978	0.062	1.317	1.062	0.120	0.445	1.057	0.800	1.125
	24.84	1.58	33.45	26.58	3.05	11.3	26.85	20.32	28.58
20	1.048	0.080	1.442	1.156	0.120	0.555	1.182	0.875	1.250
	26.62	2.03	36.63	29.36	3.05	14.10	30.02	22.23	31.75
22	1.048	0.080	1.567	1.250	0.120	0.555	1.307	0.875	1.375
	26.62	2.03	39.80	31.75	3.05	14.10	33.20	22.23	34.93
24	1.048	0.080	1.692	1.375	0.147	0.590	1.432	0.875	1.500
	26.62	2.03	42.98	34.93	3.74	14.99	36.37	22.23	38.1

12E (219)

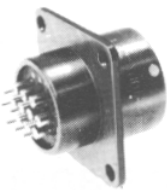

62GB-12E (219)

BS9522 - F0017 - C2262

4-hole flange mounting with plain shell
with film wire terminations

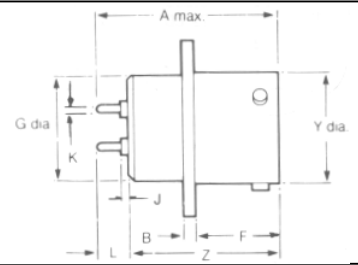
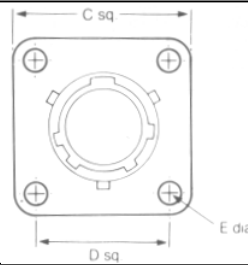

Shell Size	A max	B ± 0.005 (± 0.13)	C max sq.	D TP sq.	E dia 0.010	F ± 0.005 (± 0.13)	G dia. Max	J ± 0.020 (± 0.51)	K min max.	L max min	Y dia max.	Z
08	0.982	0.062	0.817	0.594	0.120	0.445	0.434	0.089	0.030 0.028	0.198 0.166	0.473	0.800
	24.95	1.58	20.75	15.09	3.05	11.3	11.02	2.26 0.76	0.70 5.03	4.22 12.02	20.32	
10	0.982	0.062	0.942	0.719	0.120	0.445	0.558	0.089	0.030 0.028	0.198 0.166	0.590	0.800
	24.95	1.58	23.93	18.26	3.05	11.3	14.17	2.26 0.76	0.70 5.03	4.22 14.99	20.32	
12	0.982	0.062	1.036	0.812	0.120	0.445	0.683	0.089	0.030 0.028	0.198 0.166	0.750	0.800
	24.95	1.58	26.32	20.63	3.05	11.3	17.35	2.26 0.76	0.70 5.03	4.22 19.05	20.32	
14	0.982	0.062	1.130	0.906	0.120	0.445	0.808	0.089	0.030 0.028	0.198 0.166	0.875	0.800
	24.95	1.58	28.70	23.10	3.05	11.3	20.52	2.26 0.76	0.70 5.03	4.22 22.23	20.32	
16	0.982	0.062	1.223	0.969	0.120	0.445	0.933	0.089	0.030 0.028	0.198 0.166	1.000	0.800
	24.95	1.58	31.07	24.61	3.05	11.3	23.70	2.26 0.76	0.70 5.03	4.22 25.4	20.32	
18	0.982	0.062	1.317	1.062	0.120	0.445	1.057	0.089	0.030 0.028	0.198 0.166	1.125	0.800
	24.95	1.58	33.45	26.58	3.05	11.3	26.85	2.26 0.76	0.70 5.03	4.22 28.58	20.32	
20	1.057	0.080	1.442	1.156	0.120	0.555	1.182	0.076	0.030 0.028	0.185 0.153	1.250	0.875
	26.85	2.03	36.63	29.36	3.05	14.10	30.02	1.93 0.76	0.70 4.70	3.89 31.75	22.23	
22	1.057	0.080	1.567	1.250	0.120	0.555	1.307	0.076	0.030 0.028	0.185 0.153	1.375	0.875
	26.85	2.03	39.80	31.75	3.05	14.10	33.20	1.93 0.76	0.70 4.70	3.89 34.93	22.23	
24	1.057	0.080	1.692	1.375	0.147	0.590	1.432	0.076	0.030 0.028	0.185 0.153	1.500	0.875
	26.85	2.03	42.98	34.93	3.74	14.99	36.37	1.93 0.76	0.70 4.70	3.89 38.1	22.23	

Box Mounting Receptacles Hermetic Seal

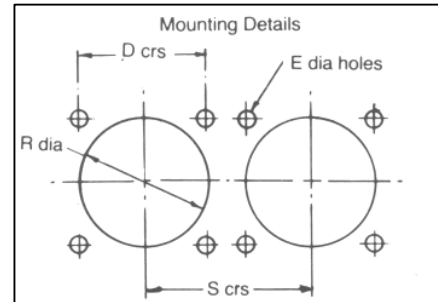

62GB-12H



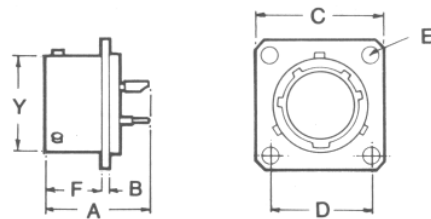



4-hole square mounting with exposed solder buckets or flattened and pierced pins.

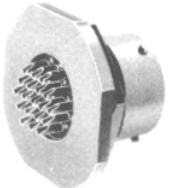
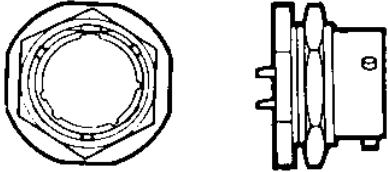

Shell Size	A max	B ± 0.005 (± 0.13)	C max sq.	D	E 0.008 (± 0.203) (±.051) .002	F ± 0.005 (± 0.13)	R ±0.005 (±0.13)	S	Y
08	0.828	0.062	0.812	0.594	0.120	0.443	0.568	1.250	0.473
	21.03	1.57	20.61	15.08	3.05	11.25	14.42	31.73	12.01
10	0.828	0.062	0.937	0.719	0.120	0.443	0.695	1.359	14.99
	21.03	1.57	23.79	18.29	3.05	11.25	17.53	34.52	14.99
12	0.828	0.062	1.031	0.812	0.120	0.443	0.864	1.531	0.750
	21.03	1.57	26.17	20.57	3.05	11.25	21.84	38.89	19.05
14	0.828	0.062	1.125	0.906	0.120	0.443	0.989	1.656	0.875
	21.03	1.57	28.57	23.11	3.05	11.25	25.15	42.06	22.23
16	0.828	0.062	1.218	0.969	0.120	0.443	1.113	1.781	1.000
	21.03	1.57	30.93	24.64	3.05	11.25	28.19	45.24	25.40
18	0.828	0.062	1.312	1.062	0.120	0.443	1.238	1.891	1.125
	21.03	1.57	33.32	26.92	3.05	11.25	31.49	48.03	28.58
20	0.890	0.093	1.437	1.156	0.120	0.561	1.363	2.031	1.250
	22.60	2.36	36.49	29.46	3.05	14.24	34.54	51.59	30.75
22	0.890	0.093	1.562	1.250	1.120	0.561	1.488	2.156	1.375
	22.60	2.36	39.67	31.75	3.05	14.24	37.85	54.76	34.93
24	0.890	0.093	1.687	1.375	0.147	0.593	1.615	2.277	1.500
	22.60	2.36	42.84	35.05	3.81	15.06	41.15	57.84	38.10

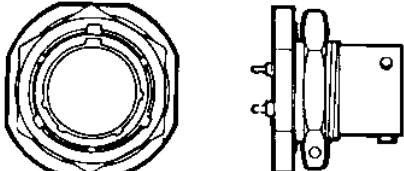
Single Hole Fixing Receptacles Table of Styles

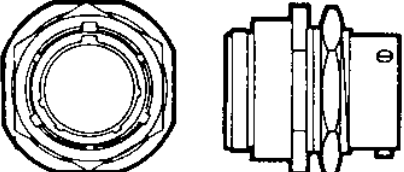
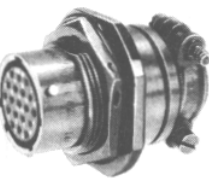
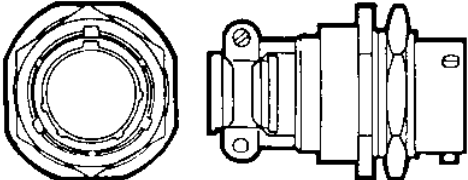
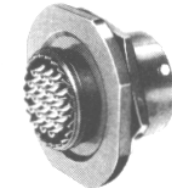
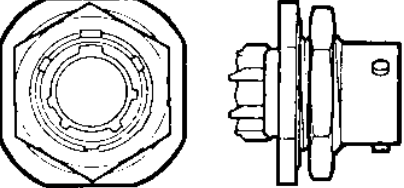
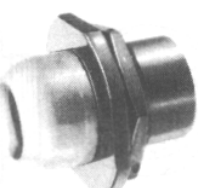
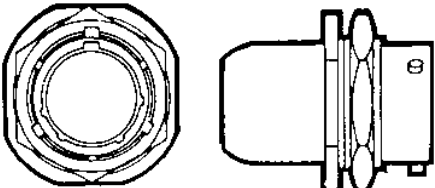
Page No.

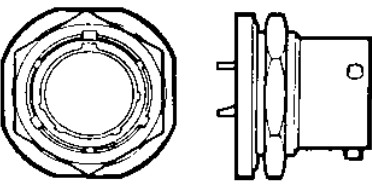
62GB-57A			23
62GB-57A (219)			23
62GB-14E			24
62GB-14F			24
62GB-57T			25
62GB-17P			25
62GB-17H Hermetic Seal			26

Single Hole Fixing Receptacles

Table of Styles

Page No.

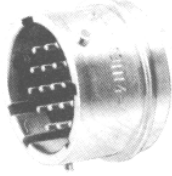
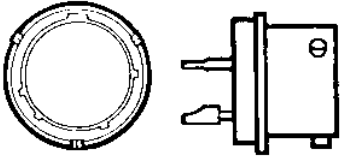
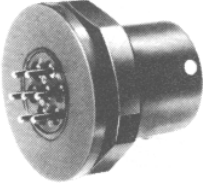
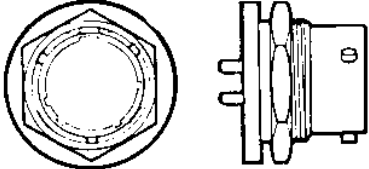
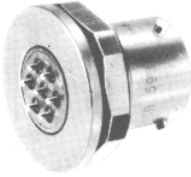
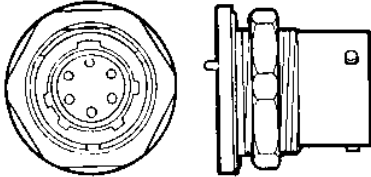
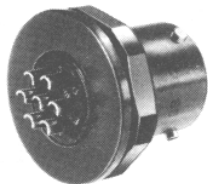
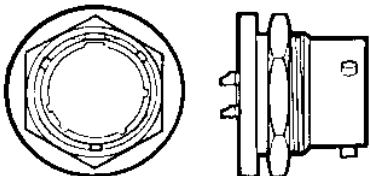
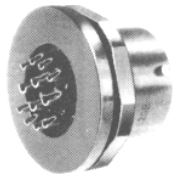
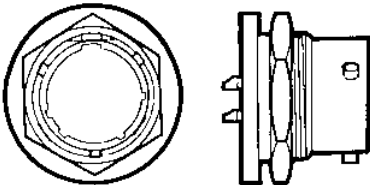
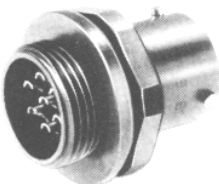
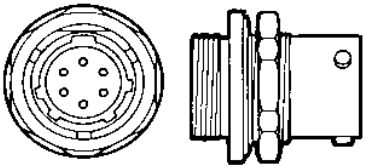
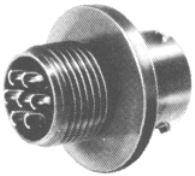
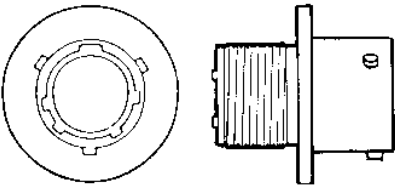
<p>62GB-13H Hermetic Seal</p>			<p>26</p>
<p>62GB-5005-10</p>			<p>27</p>
<p>62GB-5036-10</p>			<p>27</p>
<p>62GB-5016-10</p>			<p>28</p>
<p>62GB-5024</p>			<p>28</p>
<p>62GB-5052</p>			<p>29</p>
<p>62GB-5030</p>			<p>29</p>

Single Hole Fixing Receptacles

Table of Styles

Page No.

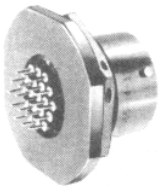
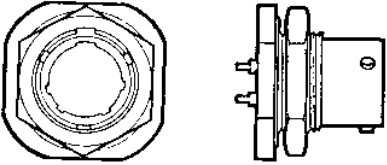
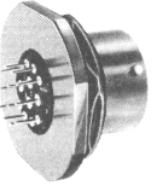
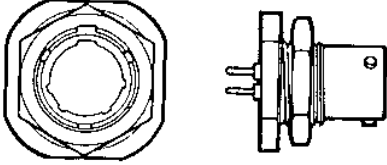
<p>62GB-5065</p>			<p>30</p>
<p>62GB-5067</p>			<p>30</p>

Single Hole Fixing Receptacles

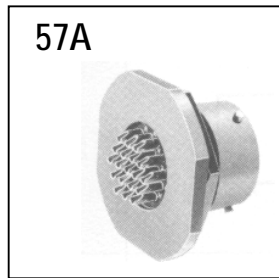
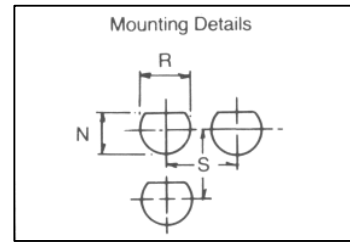

57A

62GB-57A
BS9522 - F0017 - C2099

Single hole mounting with plain shell for direct wiring to exposed solder buckets. Has panel 'O' ring seal.

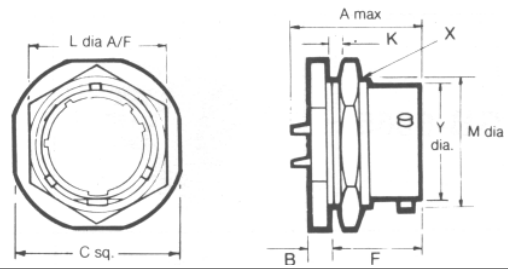

Shell Size	A max	B ±0.005 (±0.13)	C sq.	F ±0.005 (±0.13)	min	K max	L	M -0.005 (-0.13)	N ±0.005 (±0.13)	R ±0.005 (±0.13)	s min	Y	X Thread
08	0.978	0.117	0.942	0.706	0.062	0.125	0.750	0.527	0.540	0.572	1.250	0.473	9/16 - 24 NEF
	24.84	2.97	23.93	17.93	1.58	3.18	19.05	13.3	13.72	14.53	31.75	12.03	
10	0.978	0.117	1.067	0.706	0.062	0.125	0.875	0.652	0.665	0.697	1.359	0.590	11/16 -24 NEF
	24.84	2.97	27.10	17.93	1.58	3.18	22.23	16.56	16.89	17.70	34.52	14.99	
12	0.978	0.117	1.255	0.706	0.062	0.125	1.062	0.815	0.828	0.885	1.531	0.750	7/8 -20 UNEF
	24.84	2.97	31.88	17.93	1.58	3.18	26.98	20.70	21.03	22.48	38.89	19.05	
14	0.978	0.117	1.380	0.706	0.062	0.125	1.187	0.939	0.952	1.010	1.656	0.875	1 -20 UNEF
	24.84	2.97	35.05	17.93	1.58	3.18	30.15	23.85	24.18	25.65	42.06	22.23	
16	0.978	0.117	1.505	0.706	0.062	0.125	1.312	1.063	1.076	1.135	1.781	1.000	1.1/8 - 18 NEF
	24.84	2.97	38.23	17.93	1.58	3.18	33.32	27.00	27.33	28.83	45.24	25.40	
18	0.978	0.117	1.630	0.706	0.062	0.125	1.437	1.188	1.201	1.260	1.891	1.125	1.1/4 - 18 NEF
	24.84	2.97	41.40	17.93	1.58	3.18	36.50	30.18	30.50	32.00	48.03	28.58	
20	1.048	0.148	1.817	0.894	0.062	0.250	1.562	1.313	1.326	1.385	2.031	1.250	1.3/8 - 18NEF
	26.62	3.76	46.15	22.71	1.58	6.35	38.68	33.35	33.68	35.18	51.59	31.75	
22	1.048	0.148	1.942	0.894	0.062	0.250	1.687	1.438	1.451	1.510	2.156	1.375	1.1/2 - 18 NEF
	26.62	3.76	49.33	22.71	1.58	6.35	42.85	36.53	36.86	38.35	54.76	34.93	
24	1.048	0.148	2.067	0.927	0.062	0.250	1.812	1.563	1.576	1.635	2.277	1.500	1.5/8 - 18 NEF
	26.62	3.76	52.50	23.55	1.575	6.35	46.05	39.70	40.03	41.45	57.84	38.10	



57A(219)

62GB-57A (219)
BS9522 - F0017- C2261

Single hole mounting with plain shell and film wire terminations

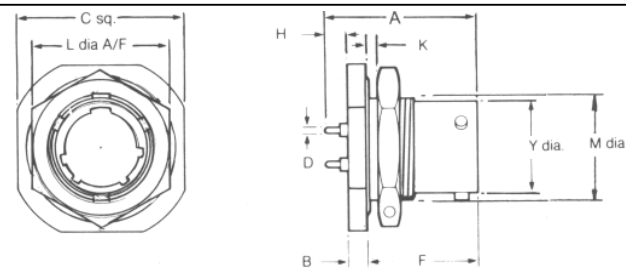

Shell Size	A m	B ±0.005 (±0.13)	C sq. max.	D min	F ±0.005 (±0.13)	H min	min	min	K max	L	M -0.005 (-0.13)	N ±0.005 (±0.13)	R ±0.005 (±0.13)	S min	Y	X Thread	
08	0.976	0.117	0.942	0.030	0.028	0.706	0.173	0.133	0.062	0.125	0.750	0.527	0.540	0.572	1.250	0.473	9/16 -24 NEF
	24.79	2.97	23.93	0.76	0.71	17.93	4.40	3.38	1.58	3.18	19.05	13.3	13.72	14.53	31.75	12.03	
10	0.976	0.117	1.067	0.030	0.028	0.706	0.173	0.133	0.062	0.125	0.875	0.652	0.665	0.697	1.359	0.590	11/16 -24 NEF
	24.79	2.97	23.93	0.76	0.71	17.93	4.40	3.38	1.58	3.18	22.23	16.56	16.89	17.70	34.52	14.99	
12	0.976	0.117	1.255	0.030	0.028	0.706	0.173	0.133	0.062	0.125	1.062	0.815	0.828	0.885	1.531	0.750	7/8 -20 UNEF
	24.79	2.97	31.88	0.76	0.71	17.93	4.40	3.38	1.58	3.18	26.98	20.70	21.03	22.48	38.89	19.05	
14	0.976	0.117	1.380	0.030	0.028	0.706	0.173	0.133	0.062	0.125	1.187	0.939	0.952	1.010	1.656	0.875	1 -20 UNEF
	24.79	2.97	35.05	0.76	0.71	17.93	4.40	3.38	1.58	3.18	30.15	23.85	24.18	25.65	42.06	22.26	
16	0.976	0.117	1.505	0.030	0.028	0.706	0.173	0.133	0.062	0.125	1.312	1.063	1.076	1.135	1.781	1.000	1.1/8 - 18 NEF
	24.79	2.97	38.23	0.76	0.71	17.93	4.40	3.38	1.58	3.18	33.32	27.00	27.33	28.83	45.24	25.40	
18	0.976	0.117	1.630	0.030	0.028	0.706	0.173	0.133	0.062	0.125	1.437	1.188	1.201	1.260	1.891	1.125	1.1/4 - 18 NEF
	24.79	2.97	41.40	0.76	0.71	17.93	4.40	3.38	1.58	3.18	36.50	30.18	30.50	32.00	48.03	28.58	
20	1.195	0.148	1.817	0.030	0.028	0.894	0.173	0.133	0.062	0.250	1.562	1.313	1.326	1.385	2.031	1.250	1.3/8 - 18 NEF
	30.35	3.76	46.15	0.76	0.71	22.71	4.40	3.38	1.58	6.35	38.68	33.35	33.68	35.18	51.59	31.75	
22	1.195	0.148	1.942	0.030	0.028	0.894	0.173	0.133	0.062	0.250	1.687	1.438	1.451	1.510	2.156	1.375	1.1/2 -18NEF
	30.35	3.76	49.33	0.76	0.71	22.71	4.40	3.38	1.58	6.35	42.85	36.53	36.86	38.35	54.76	34.93	
24	1.228	0.148	2.067	0.030	0.028	0.927	0.173	0.133	0.062	0.250	1.812	1.563	1.576	1.635	2.277	1.500	1.5/8 - 18 NEF
	30.35	3.76	52.50	0.76	0.71	23.55	4.40	3.38	1.58	6.35	46.05	39.70	40.03	41.45	57.84	38.10	

Single Hole Fixing Receptacles

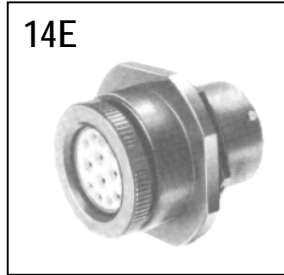
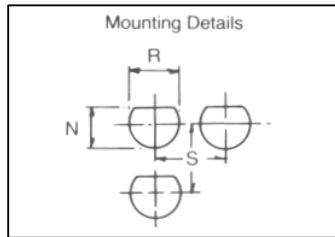

62GB-14E
MIL-C-26482 MS3114E
BS9522 - F0017
- C2098

Single hole mounting with grommet and grommet nut.
 Has panel 'O' ring seal

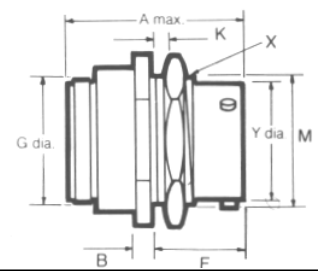
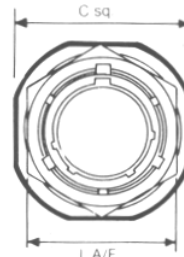

Shell Size	A max	B ±0.005 (±0.13)	C max sq.	F ±0.005 (±0.13)	G Dia Max	min	K max	L	M -0.005 (-0.13)	N ±0.005 (±0.13)	R ±0.005 (±0.13)	S	Y	X Thread
08	1.344 34.14	0.117 2.97	0.942 23.93	0.706 17.93	0.713 18.11	0.062 1.58	0.125 3.18	0.750 19.05	0.527 13.3	0.540 13.72	0.572 14.53	1.250 31.75	0.473 12.03	9/16-24NEF
10	1.344 34.14	0.117 2.97	1.067 27.10	0.706 17.93	0.838 21.29	0.062 1.58	0.125 3.18	0.875 22.23	0.652 16.56	0.665 16.89	0.697 17.70	1.359 34.52	0.590 14.99	11/16 -24 NEF
12	1.344 34.14	0.117 2.97	1.255 31.88	0.706 17.93	0.963 24.46	0.062 1.58	0.125 3.18	1.062 26.98	0.815 20.70	0.828 21.03	0.885 22.48	1.531 38.89	0.750 19.05	7/8 -20 UNEF
14	1.344 34.14	0.117 2.97	1.380 35.05	0.706 17.93	1.088 27.63	0.062 1.58	0.125 3.18	1.187 30.15	0.939 23.85	0.952 24.18	1.010 25.65	1.656 42.06	0.875 22.23	1 - 20 UNEF
16	1.344 34.14	0.117 2.97	1.505 38.23	0.706 17.93	1.213 30.81	0.062 1.58	0.125 3.18	1.312 33.32	1.063 27.00	1.076 27.33	1.135 28.83	1.781 45.24	1.000 25.40	1.1/8 -18NEF
18	1.344 34.14	0.117 2.97	1.630 41.40	0.706 17.93	1.338 33.98	0.062 1.58	0.125 3.18	1.437 36.50	1.188 30.18	1.201 30.50	1.260 32.00	1.891 48.03	1.125 28.58	1.1/4 -18 NEF
20	1.576 40.03	0.148 3.76	1.817 46.15	0.894 22.71	1.463 37.16	0.062 1.58	0.250 6.35	1.562 39.68	1.313 33.35	1.326 33.68	1.385 35.18	2.031 51.59	1.250 31.75	1.3/8 - 18 NEF
22	1.576 40.03	0.148 3.76	1.942 49.33	0.894 22.71	1.588 40.33	0.062 1.58	0.250 6.35	1.687 42.85	1.438 36.53	1.451 36.86	1.510 38.35	2.156 54.76	1.375 34.93	1.1/2 - 18 NEF
24	1.609 40.87	0.148 3.76	2.067 52.50	0.927 23.55	1.713 43.51	0.062 1.58	0.250 6.35	1.812 46.05	1.563 39.70	1.576 40.03	1.635 41.45	2.277 57.84	1.500 38.10	1.5/8 - 18 NEF



62GB-1 4F
MIL-C-26482 MS3114F

Single hole mounting with grommet and grommet nut fitted with integral strain relief clamp.
 Has panel 'O' ring seal

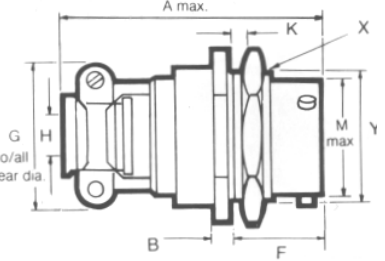
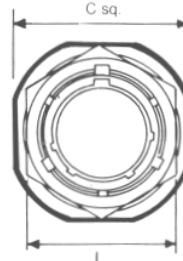

Shell Size	A max	B ±0.005 (±0.13)	C max sq.	F ±0.005 (±0.13)	G dia. max.	H 0.005 (± 0.13)	min	K max	L	M -0.005 (-0.13)	N ±0.005 (±0.13)	R ±0.005 (±0.13)	S	Y	X Thread
08	1.762 44.75	0.117 2.97	0.942 23.93	0.706 17.93	0.828 21.03	0.156 3.96	0.062 1.58	0.125 3.18	0.750 19.05	0.527 13.3	0.540 13.72	0.572 14.53	1.250 31.75	0.473 12.03	9/16 -24 NEF
10	1.762 44.75	0.117 2.97	1.067 27.10	0.706 17.93	0.891 22.63	0.188 4.78	0.062 1.58	0.125 3.18	0.875 22.23	0.652 16.56	0.665 16.89	0.697 17.70	1.359 34.52	0.590 14.99	11/16 - 124 NEF
12	1.762 44.75	0.117 2.97	1.255 31.88	0.706 17.93	1.016 25.81	0.312 7.93	0.062 1.58	0.125 3.18	1.062 26.98	0.815 20.70	0.828 21.03	0.885 22.48	1.531 38.89	0.750 19.05	7/8 - 20 UNEF
14	1.736 44.10	0.117 2.97	1.380 35.05	0.706 17.93	1.147 28.97	0.375 9.53	0.062 1.58	0.125 3.18	1.187 30.15	0.939 23.85	0.952 24.18	1.010 25.65	1.656 42.06	0.875 22.23	1 - 20 NEF
16	1.876 47.65	0.117 2.97	1.505 38.23	0.706 17.93	1.203 30.56	0.500 12.7	0.062 1.58	0.125 3.18	1.312 33.32	1.063 27.00	1.076 27.33	1.135 28.83	1.781 45.24	1.000 25.40	1.1/8 - 18 NEF
18	1.876 47.65	0.117 2.97	1.630 41.40	0.706 17.93	1.426 36.22	0.625 15.88	0.062 1.58	0.125 3.18	1.437 36.50	1.188 30.18	1.201 30.50	1.260 32.00	1.891 48.03	1.125 28.58	1.1/4 - 18 NEF
20	2.118 53.8	0.148 3.76	1.817 46.15	0.894 22.71	1.426 36.22	0.625 15.88	0.062 1.58	0.250 6.35	1.562 39.68	1.313 33.35	1.326 33.68	1.385 35.18	2.031 51.59	1.250 31.75	1.3/8 - 18 NEF
22	2.118 53.8	0.148 3.76	1.942 49.33	0.894 22.71	1.567 39.80	0.750 19.05	0.062 1.58	0.250 6.35	1.687 42.85	1.438 36.53	1.451 36.86	1.510 38.35	2.756 54.76	1.375 34.93	1.1/2 - 18 NEE
24	2.250 57.15	0.148 3.76	2.067 52.50	0.927 23.55	1.735 44.07	0.800 20.32	0.062 1.58	0.250 6.35	1.812 46.05	1.563 39.70	1.576 40.03	1.635 41.45	2.277 57.84	1.500 38.10	1.5/8 - 18 NEF

Single Hole Fixing Receptacles

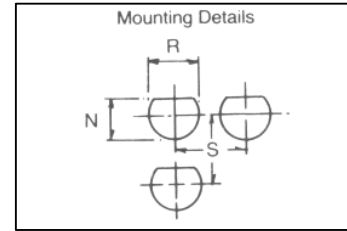

57T

62G B-57T
BS9522 - F0017 - C2100

Single hole mounting with threaded shell to accept accessories

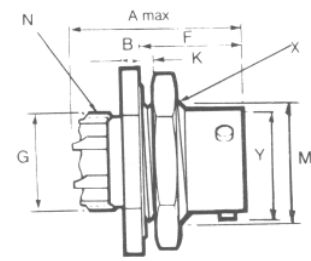
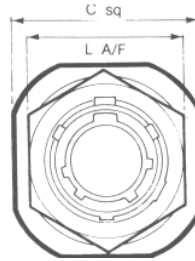

Shell Size	A max	B ±0.005 (±0.13)	c max. sq.	F ±0.005 (±0.13)	G dia. max.	min	K max	L	M -0.005 (-0.13)	N	Y	X Thread
08	0.978	0.117	0.942	0.595	0.426	0.062	0.125	0.750	0.527	7/16 - UNEF	0.473	9/16 - 24 NEF
10	24.84	2.97	23.93	15.12	10.82	1.58	3.18	19.05	13.3	12.03	0.590	11/16 - 24 NEF
12	0.978	0.117	1.067	0.595	0.552	0.062	0.125	0.875	0.652	9/16 - UNEF	0.590	11/16 - 24 NEF
14	24.84	2.97	27.10	15.12	14.02	1.58	3.18	22.23	16.56	14.99	0.750	7/8 - 20 UNEF
16	0.978	0.117	1.255	0.595	0.677	0.062	0.125	1.062	0.815	11/16 - UNEF	0.750	7/8 - 20 UNEF
18	24.84	2.97	31.88	15.12	17.20	1.58	3.18	26.98	20.70	19.05	0.875	1 - 20 UNEF
20	0.978	0.117	1.380	0.595	0.802	0.062	0.125	1.187	0.939	13/16 - UNEF	0.875	1 - 20 UNEF
22	24.84	2.97	35.05	15.12	20.37	1.58	3.18	30.15	23.85	22.23	1.000	1.1/18 - 18 NEF
24	0.978	0.117	1.505	0.595	0.927	0.062	0.125	1.312	1.063	15/16 - UNEF	1.000	1.1/18 - 18 NEF
08	24.84	2.97	38.23	15.12	23.55	1.58	3.18	33.32	27.00	25.40	1.125	1.1/4 - 18 NEF
10	0.978	0.117	1.630	0.595	1.052	0.062	0.125	1.437	1.188	1.125	1.250	1.1/4 - 18 NEF
12	24.84	2.98	41.40	15.12	26.72	1.58	3.18	36.50	30.18	28.58	1.375	1.1/4 - 18 NEF
14	1.048	0.148	1.817	0.720	1.167	0.062	0.250	1.562	1.313	1.250	1.500	1.3/8 - 18 NEF
16	26.62	3.76	46.15	18.29	29.65	1.58	6.35	38.68	33.35	31.75	1.750	1.3/8 - 18 NEF
18	1.048	0.148	1.942	0.720	1.292	0.062	0.250	1.687	1.438	1.375	1.500	1.3/8 - 18 NEF
20	26.62	3.76	49.33	18.29	32.82	1.58	6.35	42.85	36.53	34.93	1.750	1.3/8 - 18 NEF
22	1.048	0.148	2.067	0.753	1.416	0.062	0.250	1.812	1.563	1.500	1.500	1.5/8 - 18 NEF
24	26.62	3.76	52.50	19.13	35.97	1.58	6.35	46.05	39.70	38.10	1.750	1.5/8 - 18 NEF

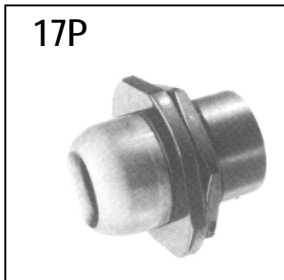

17P

62GB-17P
MIL-C-26482 MS3114P

Single hole mounting for potting. Supplied complete with potting mould locating ring and panel 'O' ring seal

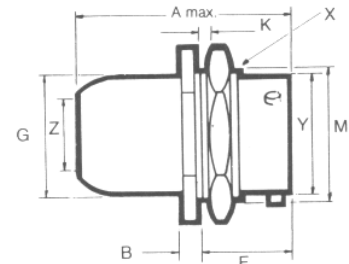
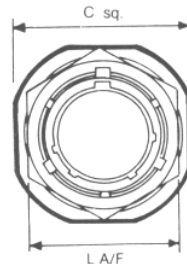

Shell Size	A max.	B ±0.005 (±0.13)	C max. sq.	F ±0.005 (±0.13)	G	min	K max.	L	M -0.005 (-0.13)	N ±0.005 (±0.13)	R ±0.005 (±0.13)	Y	Z	X Thread	
08	1.391	0.117	0.942	0.706	0.572	0.062	0.125	0.750	0.527	0.540	0.572	1.250	0.473	0.260	9/16 -24 NEF
10	35.33	2.97	23.93	17.93	14.53	1.58	3.175	19.05	13.3	13.72	14.53	31.75	12.03	6.60	9/16 -24 NEF
12	1.391	0.117	1.067	0.706	0.666	0.062	0.125	0.875	0.652	0.665	0.697	1.359	0.590	0.463	11/16 -24 NEF
14	35.33	2.97	27.10	17.93	16.92	1.58	3.18	22.23	16.56	16.89	17.70	34.52	14.99	11.76	11/16 -24 NEF
16	1.391	0.117	1.255	0.706	0.822	0.062	0.125	1.062	0.815	0.828	0.885	1.531	0.750	0.557	7/8 - 20 UNEF
18	35.33	2.97	31.88	17.93	20.88	1.58	3.18	26.98	20.70	21.03	22.48	38.89	19.05	14.15	7/8 - 20 UNEF
20	1.391	0.117	1.380	0.706	0.907	0.062	0.125	1.187	0.939	0.952	1.010	1.656	0.875	0.590	1 - 20 UNEF
22	35.33	2.97	35.05	17.93	23.06	1.58	3.18	30.15	23.85	24.18	25.65	42.06	22.23	14.99	1 - 20 UNEF
24	1.391	0.117	1.505	0.706	1.040	0.062	0.125	1.312	1.063	1.076	1.135	1.781	1.000	0.713	1.1/18 - 18 NEF
08	35.33	2.97	38.23	17.93	26.42	1.58	3.18	33.32	27.00	27.33	28.83	45.24	25.40	18.11	1.1/18 - 18 NEF
10	1.391	0.117	1.630	0.706	1.165	0.062	0.125	1.437	1.188	1.201	1.260	1.891	1.125	0.835	1.1/4 - 18 NEF
12	35.33	2.97	41.40	17.93	29.59	1.58	3.175	36.50	30.18	30.50	32.00	48.03	28.58	21.21	1.1/4 - 18 NEF
14	1.641	0.148	1.817	0.894	1.285	0.062	0.250	1.562	1.313	1.326	1.385	2.031	1.250	1.015	1.3/8 - 18 NEF
16	41.68	3.76	46.15	22.71	32.64	1.58	6.35	38.68	33.35	33.68	35.18	51.59	31.75	25.78	1.3/8 - 18 NEF
18	1.641	0.148	1.942	0.894	1.400	0.062	0.250	1.687	1.438	1.451	1.510	2.156	1.375	1.015	1.3/8 - 18 NEF
20	41.68	3.76	49.33	22.71	35.56	1.58	6.35	42.85	36.53	36.86	38.35	54.76	34.93	25.78	1.3/8 - 18 NEF
22	1.674	0.148	2.067	0.927	1.540	0.062	0.250	1.812	1.563	1.576	1.635	2.277	1.500	1.265	1.5/8 - 18 NEF
24	42.52	3.76	52.50	23.55	39.12	1.58	6.35	46.05	39.70	40.03	41.45	57.84	38.10	32.13	1.5/8 - 18 NEF

Single Hole Fixing Receptacles

Hermetic Seal

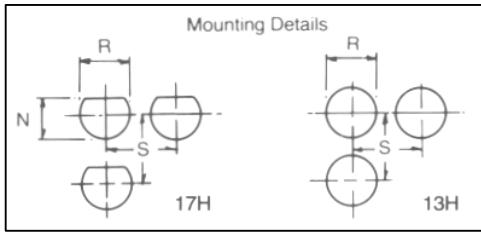

62GB-17H
MIL-C-26482 MS3114H

Single hole mounting with pin contacts in one piece glass-to-metal seal. Exposed solder buckets or flattened and pierced pins.
Has panel 'O' ring seal

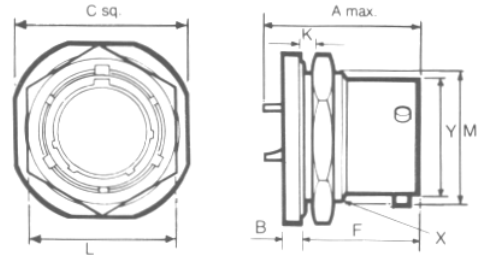

Shell Size	A max.	B ±0.005 (±0.13)	C max. sq	F ±0.005 (±0.13)	min	K max	L	M -0.005 (-0.13)	N ±0.005 (±0.13)	R ±0.005 (±0.13)	S	Y	X Thread
08	0.828	0.094	0.942	0.706	0.062	0.125	0.750	0.527	0.540	0.572	1.250	0.473	9/16 - 24 NEF
10	21.03	2.39	23.93	17.93	1.57	3.18	19.05	13.39	13.72	14.53	31.75	12.01	11/16 - 24 NEF
12	0.828	0.094	1.067	0.706	0.062	0.125	0.875	0.652	0.665	0.697	1.359	0.590	7/8 - 20 UNEF
14	21.03	2.39	27.10	17.93	1.57	3.18	22.23	16.56	16.89	17.70	34.52	14.99	1 - 20 UNEF
16	0.828	0.094	1.255	0.706	0.062	0.125	1.062	0.815	0.828	0.885	1.531	0.750	1.1/8 - 18 NEF
18	21.03	2.39	31.88	17.93	1.57	3.18	26.97	20.70	21.03	22.48	38.89	19.05	1.1/4 - 18 NEF
20	0.828	0.094	1.380	0.706	0.062	0.125	1.187	0.939	0.952	1.010	1.656	0.875	1.3/8 - 18 NEF
22	21.03	2.39	35.05	17.93	1.57	3.18	30.15	23.85	24.18	25.65	42.06	22.23	1.1/2 - 18 NEF
24	0.828	0.094	1.505	0.706	0.062	0.125	1.312	1.063	1.076	1.135	1.781	1.000	1.5/8 - 18 NEF
	21.03	2.39	38.23	17.93	1.57	3.18	33.32	27.00	27.33	28.53	45.24	25.40	
	0.828	0.094	1.630	0.706	0.062	0.125	1.437	1.188	1.201	1.260	1.891	1.125	
	21.03	2.39	41.40	17.93	1.57	3.18	36.50	30.18	30.51	32.00	48.03	28.58	
	0.828	0.125	1.817	0.894	0.062	0.250	1.562	1.313	1.326	1.385	2.031	1.250	
	21.03	3.18	46.15	22.71	1.57	6.35	39.67	33.35	33.68	35.18	51.59	30.75	
	0.890	0.125	1.942	0.894	0.062	0.250	1.687	1.438	1.451	1.510	2.156	1.375	
	22.61	3.18	49.33	22.71	1.57	6.35	42.85	36.53	36.86	38.35	54.76	34.93	
	0.890	0.125	2.067	0.927	0.062	0.250	1.812	1.563	1.576	1.635	2.277	1.500	
	22.61	3.18	52.50	23.55	1.57	6.35	46.02	39.70	40.03	41.53	57.84	38.10	



62GB-1 3H
MIL-C-26482 MS3113H

Solder mounting with plain shell and exposed solder buckets or flattened and pierced pins

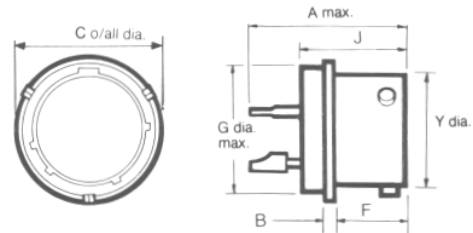

Shell Size	A max	B ±0.005 (±0.13)	c max	F ±0.005 (±0.13)	G max	J max	R ±0.005 (±0.13)	S min	Y dia. max
08	0.828	0.036	0.630	0.426	0.562	0.592	0.578	1.250	0.473
10	21.03	0.91	16.00	10.82	14.27	15.04	14.68	31.75	12.01
12	0.828	0.036	0.755	0.426	0.672	0.592	0.687	1.359	0.590
14	21.03	0.91	19.18	10.82	17.07	15.04	17.45	34.52	14.99
16	0.828	0.036	0.849	0.426	0.781	0.592	0.797	1.531	0.750
18	21.03	0.91	21.56	10.82	19.84	15.04	20.24	38.89	19.05
20	0.828	0.036	0.974	0.426	0.906	0.592	0.922	1.656	0.875
22	21.03	0.91	24.74	10.82	23.01	15.04	23.42	42.06	22.23
24	0.828	0.036	1.099	0.426	1.031	0.592	1.047	1.781	1.000
	21.03	0.91	27.91	10.82	26.19	15.04	26.59	45.24	25.40
	0.828	0.036	1.223	0.426	1.156	0.592	1.172	1.891	1.125
	21.03	0.91	31.06	10.82	29.36	15.04	29.77	48.03	28.58
	0.890	0.036	1.317	0.488	1.250	0.658	1.266	2.031	1.250
	22.61	0.91	33.45	12.40	31.75	16.70	32.16	51.59	30.75
	0.890	0.036	1.443	0.488	1.375	0.686	1.390	2.156	1.375
	22.61	0.91	36.65	12.40	34.93	17.42	35.31	54.76	34.93
	0.890	0.036	1.567	0.521	1.500	0.719	1.516	2.277	1.500
	22.61	0.91	39.80	13.23	38.10	18.26	38.51	57.84	38.10

Single Hole Fixing Receptacles

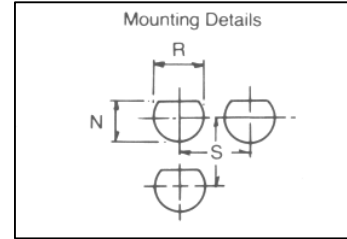

5005

62GB-5005-10
(RSRE SD/C 235025/X)

Single hole mounting plain shell with PC pin terminated contacts. Reduced diameter flange with panel 'O' seal

Size 10 only

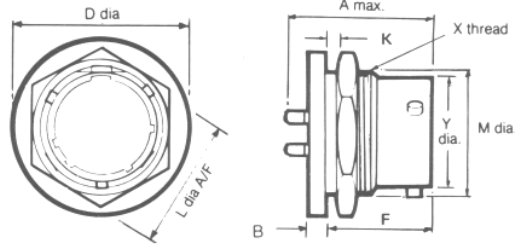

	A max	B +0.001 -0.002 (+0.03) (-0.03)	D dia. max	F +0.002 -0.003 (+0.05) (-0.08)	K min max	M -0.005 (-0.13)	N ±0.003 (±0.08)	R +0.005 (+0.13)	S	Y dia. max.	X Thread	L dia
10	0.877 22.28	0.065 1.65	0.880 22.35	0.681 17.29	0.062 1.58	0.125 3.18	0.655 16.64	0.659 16.74	0.690 17.52	1.017 25.83	0.590 14.99	11/16 – 24 NEF 0.820 20.83



5036

62GB-5036-10
(RSRE SD/C235025/X)

Single hole mounting with circular flange and P.C. terminations

Size 10 only

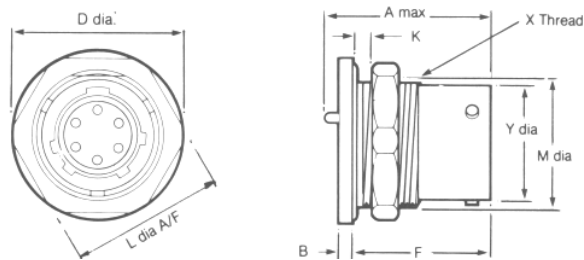

Shell Size	A max	B +0.001 -0.002 (+0.03) (-0.05)	D dia. max	F +0.002 -0.003 (+0.05) (-0.08)	Y dia. max.	K min max	M -0.005 (-0.13)	N ±0.003 (±0.08)	R +0.005 (+0.13)	S	X Thread	L dia
10	0.829 21.06	0.066 1.67	0.880 22.35	0.679 17.25	0.590 14.99	0.062 1.57	0.125 3.18	0.655 16.63	0.659 16.47	0.690 17.52	1.017 25.83	11/16 – 24 NEF 0.820 20.83

Single Hole Fixing Receptacles

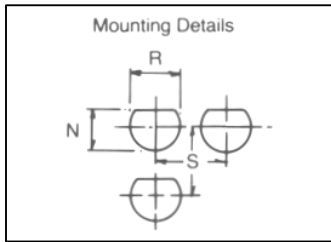

5016

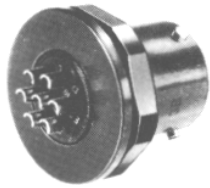

62GB-5016-10
(RSRE SD/C 235025/X)

Single hole mounting plain shell for direct wiring to exposed solder buckets. Reduced diameter flange with panel 'O' ring seal

Solder bucket: Size 10 only

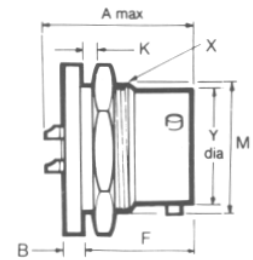
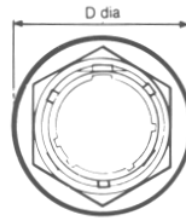

Shell Size	A max	B +0.002 -0.001 (+0.05) (-0.03)	D dia. max	F + 0.003 - 0.002 (+ 0.08) (- 0.05)	K min	K max	M - 0.010 (- 0.25)	N ± 0.005 (± 0.13)	R + 0.005 (+ 0.13)	S	Y dia. max.	X Thread
10	0.902 22.91	0.064 1.62	0.880 22.35	0.678 17.21	0.062 1.58	0.125 3.18	0.655 16.63	0.665 16.89	0.697 17.70	1.359 34.52	0.590 14.99	11/16 - 24 NEF

5024

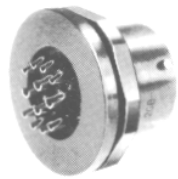

62GB-5024
(RSRE SD/C 35077/X)

Single hole mounting plain shell for direct wiring to exposed solder buckets. Reduced diameter flange with panel 'O' ring seal

Solder buckets: Size 8, 12 and 14 only

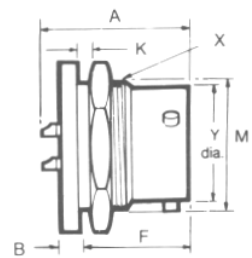
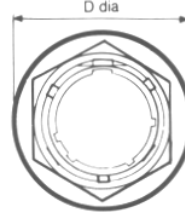

Shell Size	A max	B ± 0.005 (± 0.13)	D dia. max	F ± 0.005 (± 0.13)	K min	K max	M - 0.005 (- 0.13)	N ± 0.005 (± 0.13)	R ± 0.005 (± 0.13)	S min	Y dia. max	X Thread
08	0.978	0.117	0.830	0.706	0.062	0.125	0.527	0.540	0.572	1.250	0.473	9/16 - 24 NEF
	24.84	2.97	21.08	17.93	1.58	3.18	13.3	13.72	14.53	31.75	12.03	
12	0.978	0.117	1.130	0.706	0.062	0.125	0.815	0.828	0.885	1.531	0.750	7/8 - 20 UNEF
	24.84	2.97	28.70	17.93	1.58	3.18	20.70	21.03	22.48	38.89	19.05	
14	0.978	0.117	1.260	0.706	0.062	0.125	0.939	0.952	1.010	1.656	0.875	1 - 20 UNEF
	24.84	2.97	32.00	17.93	1.58	3.18	23.85	24.18	25.65	42.06	22.23	

Single Hole Fixing Receptacles

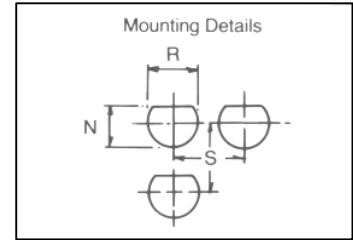

62GB-5052-10

Single hole fixing with circular flange and back end thread - solder termination

Size 10 only

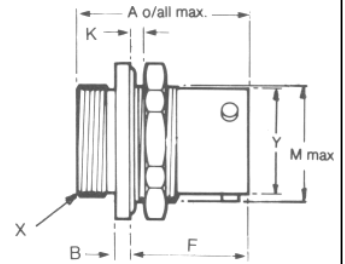
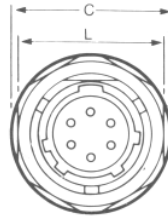

Shell Size	A max	B (± 0.05) (± 0.03)	C max. sq.	F + 0.003 - 0.002 (+ 0.08) (- 0.05)	K min max	L	M - 0.005 (- 0.13)	N ± 0.005 (± 0.13)	R ± 0.005 (± 0.13)	S ± 0.005 (± 0.13)	X Thread
10	0.947 24.06	0.062 1.58	0.880 22.35	0.677 17.19	0.062 1.58 0.125 3.18	0.820 20.83	0.650 16.51	5/8 - 24 UNEF	0.697 17.70	1.359 34.52	5/8 - 24 NEF



62GB-5030

Bulkhead mounting receptacle with solder terminations

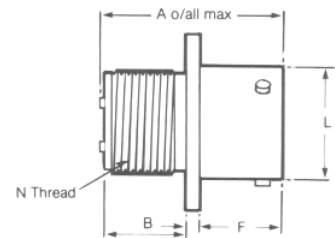
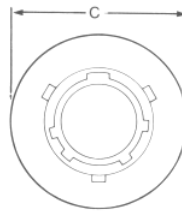

Shell Size	A max	B ± 0.005 (± 0.13)	C ± 0.010 (± 0.25)	F ± 0.005 (± 0.13)	L	N Thread
08	0.978	0.094	0.812	0.415	0.563	7/16 - 28 UNEF
	24.85	2.39	20.63	10.54	14.30	
10	0.978	0.094	0.937	0.415	0.680	9/16 - 24 NEF
	24.85	2.39	23.80	10.54	17.28	
12	0.978	0.094	1.031	0.415	0.859	11 /16 - 24 NEF
	24.85	2.39	26.19	10.54	21.82	
14	0.978	0.094	1.125	0.415	0.984	13/16 - 20 UNEF
	24.85	2.39	28.58	10.54	25.00	
16	0.978	0.094	1.218	0.415	1.108	15/16 - 20 UNEF
	24.85	2.39	30.94	10.54	28.15	
18	0.978	0.094	1.3121	0.415	1.233	1.1/16 - 18NEF
	24.85	2.39	33.33	10.54	31.32	
20	1.048	0.102	1.437	0.535	1.358	1.3/16 - 18NEF
	26.62	2.59	36.50	13.59	34.50	
22	1.048	0.102	1.562	0.535	1.483	1.5/16 - 18 NEF
	26.62	2.59	39.68	13.59	37.67	
24	1.048	0.102	1.687	0.572	1.610	1.7/16 - 18 NEF
	26.62	2.59	42.85	14.53	40.90	

Single Hole Fixing Receptacles

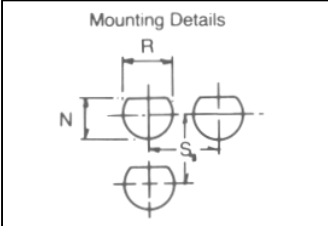

62G B-5065
BS9522-F0017 C2261

Single hole mounting with plain shell and film wire terminations

Shell Size	A max	B ± 0.005 (± 0.13)	C sq.	D max	D min	F ± 0.005 (± 0.13)	H max	H min	J ± 0.020 (± 0.51)	K min	K max	L	M -0.005 (-0.13)	N ± 0.005 (± 0.13)	R ± 0.005 (± 0.13)	S	Y	X Thread
08	1.021	0.117	0.942	0.030	0.028	0.706	0.218	0.178	0.060	0.062	0.125	0.750	0.527	0.540	0.572	1.250	0.473	9/16 - 24 NEF
	25.94	2.97	23.93	0.76	0.71	17.93	5.54	4.52	1.52	1.58	3.18	19.05	13.3	13.72	14.53	31.75	12.03	
10	1.021	0.117	1.067	0.030	0.028	0.706	0.218	0.178	0.060	0.062	0.125	0.875	0.652	0.665	0.697	1.359	0.590	11/16 - 24 NEF
	25.94	2.97	27.10	0.76	0.71	17.93	5.54	4.52	1.52	1.58	3.18	22.23	16.56	16.89	17.70	34.52	14.99	
12	1.021	0.117	1.255	0.030	0.028	0.706	0.218	0.178	0.060	0.062	0.125	1.062	0.815	0.828	0.885	1.531	0.750	7/8 - 20 UNEF
	25.94	2.97	31.88	0.76	0.71	17.93	5.54	4.52	1.52	1.58	3.18	26.98	20.70	21.03	22.48	38.89	19.05	
14	1.021	0.117	1.380	0.030	0.028	0.706	0.218	0.178	0.060	0.062	0.125	1.187	0.939	0.952	1.010	1.656	0.875	1 - 20 UNEF
	25.94	2.97	35.05	0.76	0.71	17.93	5.54	4.52	1.52	1.58	3.18	30.15	23.85	24.18	25.65	42.06	22.23	
16	1.021	0.117	1.505	0.030	0.028	0.706	0.218	0.178	0.060	0.062	0.125	1.312	1.063	1.076	1.135	1.781	1.000	1.1/8 - 18 NEF
	25.94	2.97	38.23	0.76	0.71	17.93	5.54	4.52	1.52	1.58	3.18	33.32	27.00	27.33	28.83	45.24	25.40	
18	1.021	0.117	1.630	0.030	0.028	0.706	0.218	0.178	0.060	0.062	0.125	1.437	1.188	1.201	1.260	1.891	1.125	1.1/4 - 18 NEF
	25.94	2.97	41.40	0.76	0.71	17.93	5.54	4.52	1.52	1.58	3.18	36.50	30.18	30.50	32.00	48.03	28.58	
20	1.240	0.148	1.817	0.030	0.028	0.894	0.218	0.178	0.060	0.062	0.250	1.562	1.313	1.326	1.385	2.031	1.250	1.3/8 - 18 NEF
	31.50	3.76	46.15	0.76	0.71	22.71	5.54	4.52	1.52	1.58	6.35	38.68	33.35	33.68	35.18	51.59	31.75	
22	1.240	0.148	1.942	0.030	0.028	0.894	0.218	0.178	0.060	0.062	0.250	1.687	1.438	1.451	1.510	2.156	1.375	1.1/2 - 18 NEF
	31.50	3.76	49.33	0.76	0.71	22.71	5.54	4.52	1.52	1.58	6.35	42.85	36.53	36.85	38.35	54.76	34.93	
24	1.273	0.148	2.067	0.030	0.028	0.927	0.218	0.178	0.060	0.062	0.250	1.812	1.563	1.576	1.635	2.277	1.500	1.5/8 - 18 NEF
	32.34	3.76	52.50	0.76	0.71	23.55	5.54	4.52	1.52	1.58	6.35	46.05	39.70	40.03	41.45	57.84	38.10	



62GB-5067
BS9522 - F0017 - C2261



Single hole mounting with plain shell and film wire terminations

Shell Size	A max	B ± 0.005 (± 0.13)	C max sq	D max	D min	F ± 0.005 (± 0.13)	H max	H min	J ± 0.012 (± 0.30)	K min	K max	L	M -0.005 (-0.13)	N ± 0.005 (± 0.13)	R ± 0.005 (± 0.13)	S	Y	X Thread
08	1.095	0.117	0.942	0.030	0.028	0.706	0.262	0.230	0.049	0.062	0.125	0.750	0.527	0.540	0.572	1.250	0.473	9/16 - 24 NEF
	27.81	2.97	23.93	0.76	0.71	17.93	6.66	5.85	1.24	1.58	3.18	19.05	13.3	13.72	14.53	31.75	12.03	
10	1.095	0.117	1.067	0.030	0.028	0.706	0.262	0.230	0.049	0.062	0.125	0.875	0.652	0.665	0.697	1.359	0.590	11/16 - 24 NEF
	27.81	2.97	27.10	0.76	0.71	17.93	6.66	5.85	1.24	1.58	3.18	22.23	16.56	16.89	17.70	34.52	14.99	
12	1.095	0.117	1.255	0.030	0.028	0.706	0.262	0.230	0.049	0.062	0.125	1.062	0.815	0.828	0.885	1.531	0.750	7/8 - 20 UNEF
	27.81	2.97	31.88	0.76	0.71	17.93	6.66	5.85	1.24	1.58	3.18	26.98	20.70	21.03	22.50	38.89	19.05	
14	1.095	0.117	1.380	0.030	0.028	0.706	0.262	0.230	0.049	0.062	0.125	1.187	0.939	0.952	1.010	1.656	0.875	1 - 20 UNEF
	27.81	2.97	35.10	0.76	0.71	17.93	6.66	5.85	1.24	1.58	3.18	30.15	23.85	24.18	25.65	42.06	22.23	
16	1.095	0.117	1.505	0.030	0.028	0.706	0.262	0.230	0.049	0.062	0.125	1.312	1.063	1.076	1.135	1.781	1.000	1.1/8 - 18 NEF
	27.81	2.97	38.23	0.76	0.71	17.93	6.66	5.85	1.24	1.58	3.18	33.23	27.00	27.33	28.83	45.24	25.40	
18	1.095	0.117	1.630	0.030	0.028	0.706	0.262	0.230	0.049	0.062	0.125	1.437	1.188	1.201	1.260	1.891	1.125	1.1/4 - 18 NEF
	27.81	2.97	41.40	0.76	0.71	17.93	6.66	5.85	1.24	1.58	3.18	36.50	30.18	30.51	32.00	48.03	28.58	
20	1.309	0.148	1.817	0.030	0.028	0.894	0.262	0.230	0.049	0.062	0.250	1.562	1.313	1.326	1.385	2.031	1.250	1.3/8 - 18 NEF
	33.24	3.76	46.15	0.76	0.71	22.71	6.66	5.85	1.24	1.58	6.35	38.68	33.35	33.68	35.18	51.59	31.75	
22	1.309	0.148	1.942	0.030	0.028	0.894	0.262	0.230	0.049	0.062	0.250	1.687	1.438	1.451	1.510	2.156	1.375	1.1/2 - 18 NEF
	33.24	3.76	49.33	0.76	0.71	22.71	6.66	5.85	1.24	1.58	6.35	42.85	36.53	36.86	38.35	54.76	34.93	
24	1.342	0.148	2.067	0.030	0.028	0.927	0.262	0.230	0.049	0.062	0.250	1.812	1.563	1.576	1.635	2.277	1.500	1.5/8 - 18 NEF
	34.08	3.76	52.50	0.76	0.71	23.55	6.66	5.85	1.24	1.58	6.35	46.03	39.07	40.03	41.59	57.84	38.10	

Cable Mounting Receptacles

Table of Styles

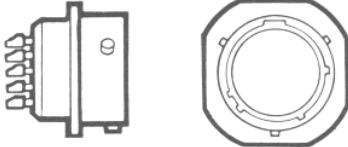
Page No.

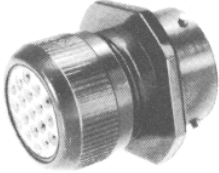
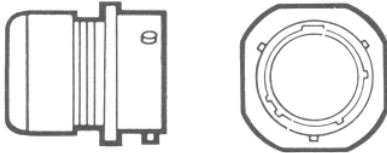
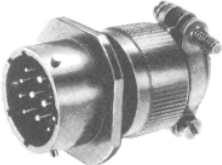
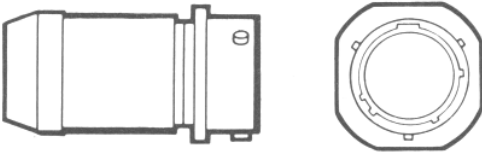
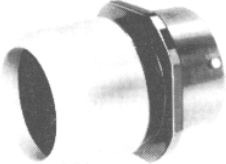
62GB-51T			32
62GB-11A			32
62GB-11E			33
62GB-11F			33
62GB-11J			34
62GB-11P			34

Cable Mounting Receptacles

51T



62GB-51T
BS9522-F0017-C2101

Basic cable mounting receptacle with threaded shell to accept standard cable accessories.

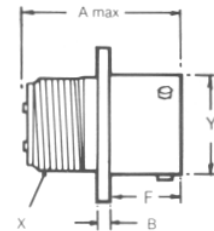
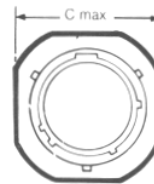

Shell Size	A max	B ± 0.005 (± 0.13)	C max sq	F ± 0.005 (± 0.13)	Y dia max	X Thread
08	0.978	0.094	0.817	0.415	0.473	7/16 - 28 UNEF
	24.84	2.39	20.75	10.54	12.03	
10	0.978	0.094	0.942	0.415	0.590	9/16 - 24 NEF
	24.84	2.39	23.93	10.54	14.99	
12	0.978	0.094	1.036	0.415	0.750	11 /16 - 24 NEF
	24.84	2.39	26.32	10.54	19.05	
14	0.978	0.094	1.130	0.415	0.875	13/16 - 20 UNEF
	24.84	2.39	28.70	10.54	22.23	
16	0.978	0.094	1.223	0.415	1.000	15/16 - 20 UNEF
	24.84	2.39	31.07	10.54	25.40	
18	0.978	0.094	1.317	0.415	1.125	1.1/16 -18 NEF
	24.84	2.39	33.45	10.54	28.58	
20	1.048	0.102	1.442	0.535	1.250	1.3/16 -18 NEF
	26.62	2.59	36.63	13.59	31.75	
22	1.048	0.102	1.567	0.535	1.375	1.5/16 -18 NEF
	26.62	2.59	39.80	13.59	34.93	
24	1.048	0.102	1.692	0.560 / 0.574	1.500	1.7/16 -18 NEF
	26.62	2.59	42.98	14.23 / 14.58	38.10	

11A



62GB-11A

Cable mounting receptacle with general duty back shell. No grommet supplied.

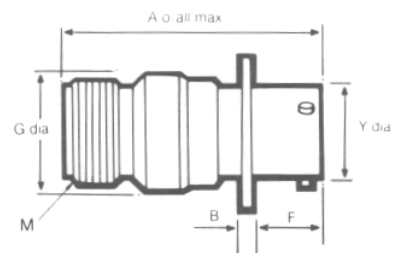
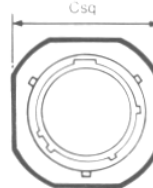

Shell Size	A max	B ± 0.005 (± 0.13)	C max sq	F ± 0.005 (± 0.13)	G dia max	Y Dia max	M Thread
08	1.624	0.094	0.817	0.415	0.561	0.473	1/2 - 28 UNEF
	41.25	2.39	20.75	10.54	14.25	12.03	
10	1.624	0.094	0.942	0.415	0.686	0.590	5/8 - 24 NEF
	41.25	2.39	23.93	10.54	17.43	14.99	
12	1.624	0.094	1.036	0.415	0.811	0.750	3/4 - 20 UNEF
	41.25	2.39	26.32	10.54	20.60	19.05	
14	1.624	0.094	1.130	0.415	0.936	0.875	7/8 - 20 UNEF
	41.25	2.39	28.70	10.54	23.78	22.23	
16	1.624	0.094	1.223	0.415	1.061	1.000	1 - 20 UNEF
	41.25	2.39	31.07	10.54	26.95	25.40	
18	1.624	0.094	1.317	0.415	1.186	1.125	1.3/16 - 18 NEF
	41.25	2.39	33.45	10.54	30.13	28.58	
20	1.687	0.104 / 0.100	1.442	0.535	1.311	1.250	1.3/16 -18 NEF
	42.85	2.64 / 2.55	36.63	13.59	33.30	31.75	
22	1.687	0.104 / 0.100	1.567	0.535	1.436	1.375	1.7/16 -18 NEF
	42.85	2.64 / 2.55	39.80	13.59	36.75	34.93	
24	1.730	0.104 / 0.100	1.692	0.569 / 0.574	1.561	1.500	1.7/16 -18 NEF
	43.94	2.64 / 2.55	42.98	14.45 / 14.58	39.65	38.10	

Cable Mounting Receptacles

11E



62GB-11E
MIL-C-26482 MS3111E

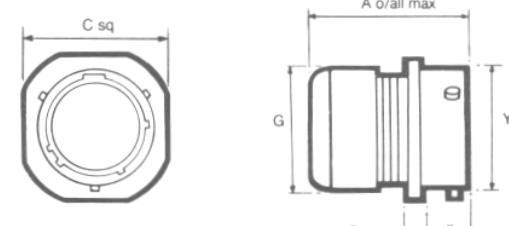

Cable mounting receptacle with grommet and grommet nut

Shell Size	A max	B ± 0.005 (± 0.13)	C max sq	F ± 0.005 (± 0.13)	G dia max	Y dia max
08	1.281	0.094	0.817	0.415	0.561	0.473
	32.54	2.39	20.75	10.54	14.25	12.03
10	1.281	0.094	0.942	0.415	0.686	0.590
	32.54	2.39	23.93	10.54	17.43	14.99
12	1.281	0.094	1.036	0.415	0.811	0.750
	32.54	2.39	26.32	10.54	20.60	19.05
14	1.281	0.094	1.130	0.415	0.936	0.875
	32.54	2.39	28.70	10.54	23.78	22.23
16	1.281	0.094	1.223	0.415	1.061	1.000
	32.54	2.39	31.07	10.54	26.95	25.40
18	1.281	0.094	1.317	0.415	1.186	1.125
	32.54	2.39	33.45	10.54	30.13	28.58
20	1.383	0.102	1.442	0.535	1.311	1.250
	35.13	2.59	36.63	13.59	33.30	31.75
22	1.383	0.102	1.567	0.535	1.436	1.375
	35.13	2.59	39.80	13.59	36.75	34.93
24	1.383	0.102	1.692	0.569 / 0.574	1.561	1.500
	35.13	2.59	42.98	14.45 / 14.58	39.65	38.10

11F



62GB-11F
MIL-C-26482 MS3111F

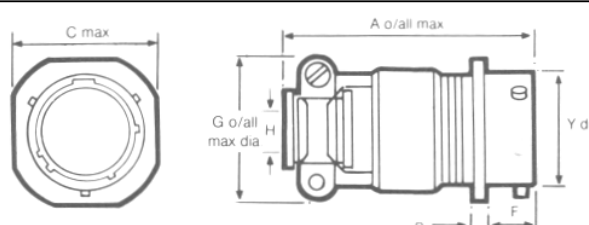

Cable mounting receptacle with grommet and grommet nut fitted with integral strain relief clamp

Shell Size	A max	B ± 0.005 (± 0.13)	C max sq	F ± 0.005 (± 0.13)	G dia max	H ± 0.005 (± 0.13)	Y dia max
08	1.762	0.094	0.817	0.415	0.828	0.156	0.473
	44.75	2.39	20.75	10.54	21.03	3.96	12.03
10	1.762	0.094	0.942	0.415	0.891	0.188	0.590
	44.75	2.39	23.93	10.54	22.63	4.78	14.99
12	1.762	0.094	1.036	0.415	1.016	0.312	0.750
	44.75	2.39	26.32	10.54	25.81	7.93	19.05
14	1.736	0.094	1.130	0.415	1.141	0.375	0.875
	44.10	2.39	28.70	10.54	28.97	9.53	22.23
16	1.876	0.094	1.223	0.415	1.203	0.500	1.000
	47.65	2.39	31.07	10.54	30.56	12.7	25.40
18	1.876	0.094	1.317	0.415	1.426	0.625	1.125
	47.65	2.39	33.45	10.54	36.22	15.88	28.58
20	2.118	0.104 / 0.100	1.442	0.535	1.426	0.625	1.250
	53.80	2.64 / 2.55	36.63	13.59	36.22	15.88	31.75
22	2.118	0.104 / 0.100	1.567	0.535	1.567	0.750	1.375
	53.80	2.64 / 2.55	39.80	13.59	39.80	19.05	34.93
24	2.250	0.104 / 0.100	1.692	0.569 / 0.574	1.735	0.800	1.500
	57.15	2.64 / 2.55	42.98	14.45 / 14.58	44.07	20.32	38.10

Cable Mounting Receptacles

11J

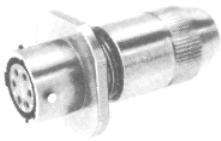

62GB-11J

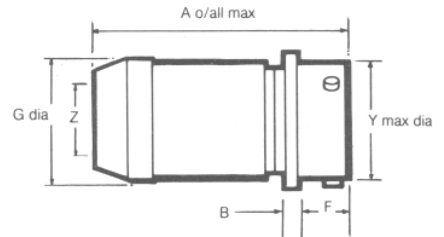
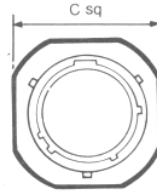

With cable clamp for unscreened jacketed cable. No grommet supplied

Shell Size	A max	B ± 0.005 (± 0.13)	C max sq	F ± 0.005 (± 0.13)	G dia max	Y dia max	min closed	Z max free
08	1.846	0.094	0.817	0.415	0.561	0.473	0.168	0.230
	46.89	2.39	20.75	10.54	14.25	12.03	4.28	5.84
10	1.846	0.094	0.942	0.415	0.686	0.590	0.205	0.312
	46.89	2.39	23.93	10.54	17.43	14.99	5.21	7.93
12	1.947	0.094	1.036	0.415	0.811	0.750	0.338	0.442
	49.45	2.39	26.32	10.54	20.60	19.05	8.59	11.23
14	2.147	0.094	1.130	0.415	0.936	0.875	0.416	0.539
	54.54	2.39	28.70	10.54	23.78	22.23	10.57	13.69
16	2.347	0.094	1.223	0.415	1.061	1.000	0.550	0.616
	59.61	2.39	31.07	10.54	26.95	25.40	13.97	15.65
18	2.547	0.094	1.317	0.415	1.186	1.125	0.600	0.672
	64.70	2.39	33.45	10.54	30.13	28.58	15.24	17.07
20	2.831	0.102	1.442	0.535	1.311	1.250	0.635	0.747
	71.91	2.59	36.63	13.59	33.30	31.75	16.13	18.98
22	3.031	0.102	1.567	0.535	1.436	1.375	0.670	0.846
	76.99	2.59	39.80	13.59	36.75	34.93	17.02	21.49
24	3.074	0.102	1.692	0.569 / 0.574	1.561	1.500	0.740	0.894
	78.03	2.59	42.98	14.45 / 14.58	39.65	38.10	18.80	22.71

11P

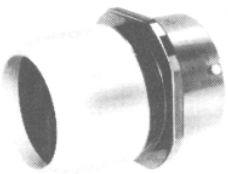

62GB-11P
MIL-C-26482 MS3111P

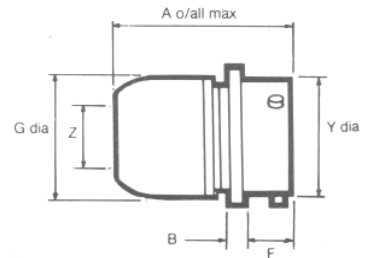
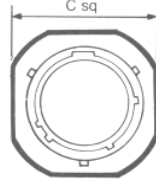

For potted seal supplied complete with detachable potting mould and location ring

Shell Size	A max	8 ± 0.005 (± 0.13)	C max sq	F ± 0.005 (± 0.13)	G dia max	Y dia max	Z min
08	1.316	0.094	0.817	0.415	0.572	0.473	0.260
	33.43	2.39	20.75	10.54	14.53	12.03	6.60
10	1.425	0.094	0.942	0.415	0.666	0.590	0.463
	36.20	2.39	23.93	10.54	16.92	14.99	11.76
12	1.394	0.094	1.036	0.415	0.822	0.750	0.557
	35.41	2.39	26.32	10.54	20.88	19.05	14.15
14	1.394	0.094	1.130	0.415	0.907	0.875	0.590
	35.41	2.39	28.70	10.54	23.04	22.23	14.99
16	1.394	0.094	1.223	0.415	1.040	1.000	0.713
	35.41	2.39	31.07	10.54	26.42	25.40	18.11
18	1.394	0.094	1.317	0.415	1.165	1.125	0.835
	35.41	2.39	33.45	10.54	29.59	28.58	22.21
20	1.612	0.102	1.442	0.535	1.285	1.250	1.015
	40.95	2.59	36.63	13.59	32.64	31.75	25.78
22	1.612	0.102	1.567	0.535	1.400	1.375	1.015
	40.95	2.59	39.80	13.59	35.56	34.93	25.78
24	1.674	0.102	1.692	0.569 / 0.574	1.540	1.500	1.265
	42.52	2.59	42.98	14.45 / 14.58	39.12	38.10	32.13

Insert Orientations

For M I L-C-26482 and for replacement purposes in BS9522 FOO 17

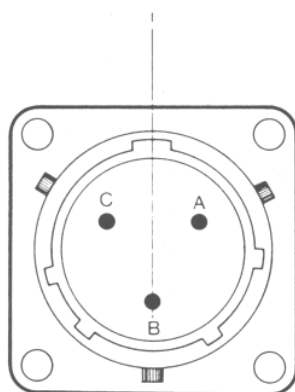

Normal position
with pin contacts

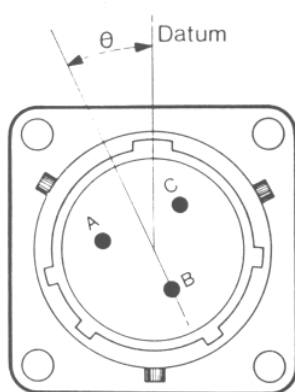

Alternative position of insert
with socket contacts
(∅ counterclockwise)

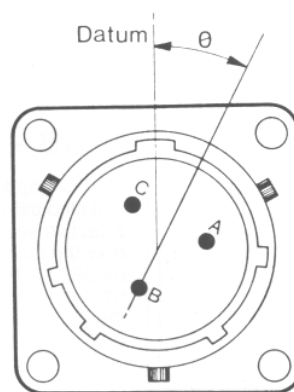

Alternate position of insert
with pin contacts
(∅ clockwise)

Each diagram shows mating face of insert.

Insert Arrangement	Normal	Orientation ∅ (degrees)			Z
		W	X	Y	
8-2	0	58	122	-	-
8-3	0	60	210	-	-
8-33	0	90	-	-	-
8-4	0	45	-	-	-
8-98	0	-	-	-	-
10-2	0	-	-	-	-
10-6	0	90	-	-	-
10-7	0	-	-	-	-
12-3	0	-	-	180	-
12-10	0	60	155	270	295
14-5	0	40	92	184	273
14-12	0	43	90	-	-
14-15	0	17	110	155	234
14-19	0	30	165	315	-
16-18	0	54	152	180	331
16-23	0	158	270	-	-
16-26	0	60	-	275	338
18-11	0	62	119	241	340
18-32	0	85	138	222	265
20-16	0	238	318	333	347
20-41	0	45	126	225	-
22-21	0	16	135	175	349
22-55	0	30	142	226	314
24-61	0	90	180	270	324

Key/Keyway Orientations

For BS9522 F0017

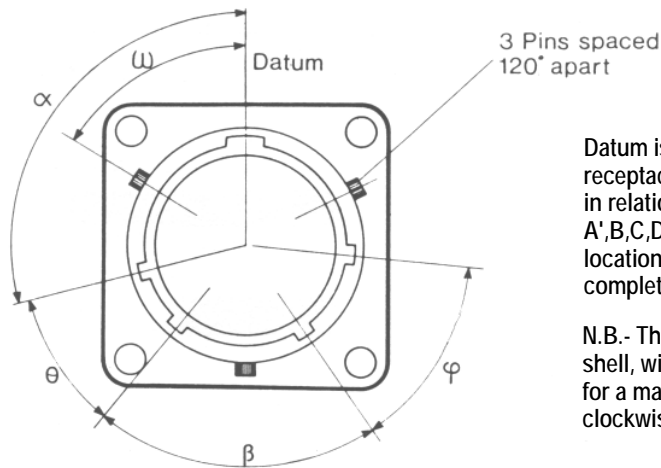

Datum is always taken from major key or keyway. In receptacles the major keyway always remains fixed in relation to the mounting flange. For the A',B,C,D',E and F orientations, the three bayonet locations and associated minor keyways are rotated complete, in accordance with the table below.

N.B.- The accompanying diagram shows a receptacle shell, with keyways. Corresponding key orientations for a mating plug shell are therefore always clockwise.

Shell Size	Values for α (degrees)						Values for θ (degrees)						Values for β (degrees)								
	N	A*	B	C	D*	E	F	N	A*	B	C	D*	E	F	N	A*	B	C	D*	E	F
8	105	92	-	-	118	118	82	35	35	-	-	35	30	50	75	75'	-	-	75	100	75
10	105	95	85	125	115	115	85	35	35	35	35	35	30	50	75	75	75	75	75	100	75
12	105	97	89	121	113	115	85	35	35	35	35	35	30	50	75	75	75	75	75	100	75
14	105	98	91	119	112	75	120	35	35	35	35	35	30	50	75	75	75	75	75	100	75
16	105	99	93	117	111	75	120	35	35	35	35	35	30	50	75	75	75	75	75	100	75
18	105	100	95	115	110	75	120	35	35	35	35	35	30	50	75	75	75	75	75	100	75
20	105	100	95	115	110	75	120	35	35	35	35	35	30	50	75	75	75	75	75	100	75
22	105	101	97	113	109	75	120	35	35	35	35	35	30	50	75	75	75	100	75	75	75
24	105	101	97	113	109	75	120	35	35	35	35	35	30	50	75	75	75	75	75	100	75

Shell Size	Values for ϕ (degrees) Orientation							Values for ω (degrees) Orientation						
	N	A*	B	C	D*	E	F	N	A*	B	C	D*	E	F
8	50	50	50	50	50	30	45	60	47	-	-	73	73	47
10	50	50	50	50	50	30	45	60	50	40	80	70	70	50
12	50	50	50	50	50	30	45	60	52	44	76	68	70	50
14	50	50	50	50	50	30	35	60	53	46	74	67	30	75
16	50	50	50	50	50	30	35	60	54	48	72	66	30	75
18	50	50	50	50	50	30	35	60	55	50	70	65	30	75
20	50	50	50	50	50	30	35	60	55	50	70	65	30	75
22	50	50	50	50	50	30	35	60	56	52	68	64	30	75
24	50	50	50	50	50	30	35	60	56	52	68	64	30	75

* now inactive for new designs but available for replacement purposes. Superseded in BS9522 F0017 by orientations E and F.

62 GB- Series Accessories

CE-2Aa

Miniature Bayonet Lock Connectors
Complies with MIL-C-26482

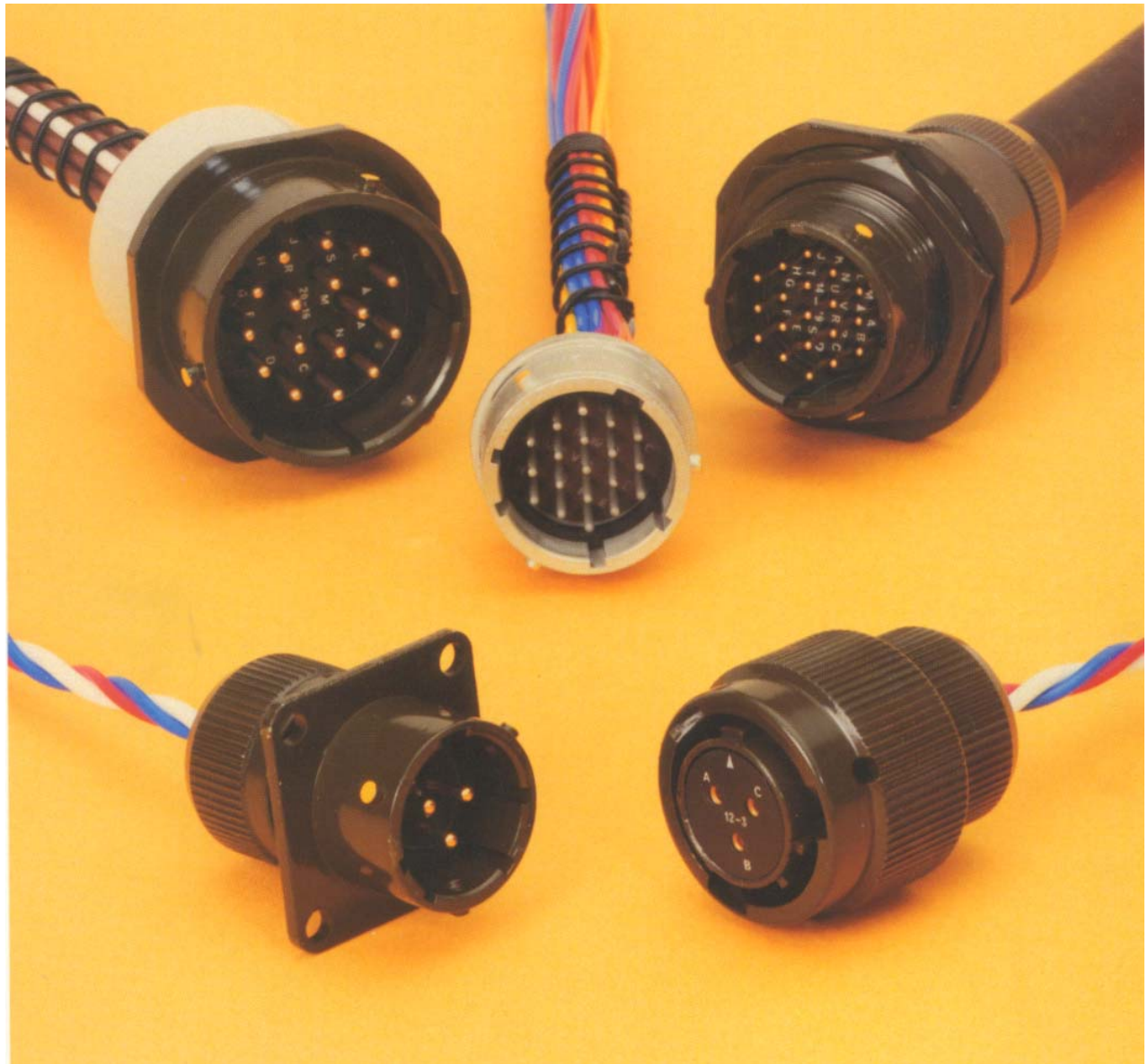

This miniature bayonet lock connector series offers designers important features not found in any other range of connectors.

They are developed and manufactured entirely in the U.K. by AMPHENOL Ltd., and have full qualification approval to British Standards Specification BS 9522 F0017 and British Defence Specification DEF STAN 59-35 (Part 3) Sec. 7.

This catalogue to be used in conjunction with Catalogues:
CE-2Pa – 62GB Series Plugs
CE-2Ra – 62GB Series Receptacles

Amphenol

CONTENTS

Page

Amphenol 62GB Solder Connectors	3
Schedule of Tests	4-5
Accessories - Table of Styles	6-7
Accessories	8-14
Cable Accessories - Table of Styles	15-16
Cable Accessories	17-21

This catalogue to be used in conjunction with Catalogues:
CE-2Pa – 62GB Series Plugs
CE-2Ra – 62GB Series Receptacles

Amphenol® 62GB solder connectors

This miniature bayonet lock connector series offers designers important features not found in any other range of connectors. The range has full qualification approval to British Standards Specification BS 9522 FOO 17 and British Defence Specification DEF STAN 59-35 (Part 3) Sec. 7.

62GB Series connectors - developed and manufactured entirely in the United Kingdom by Amphenol Limited. They are the first and only British connectors to have achieved this. A doubly strong position which Amphenol are well geared to handle. The manufacturing facilities of the Whitstable plant have been cited as exemplary in Europe. Certainly the layout is extensive and extremely efficient; safety awards have been attained every time returns have been submitted to the British Safety Council.

62GB Series connectors have been well established with Government authorities on an international scale and users can be found in Sweden, Denmark, Norway, Finland, Germany, Spain, Holland, India, Canada and Italy.

Derating

Connectors must be derated under the following operating conditions:

1. At elevated ambient temperatures, the current ratings are reduced so that total maximum hot spot temperature of 125°C is not exceeded.
2. At high altitudes, revised voltage ratings become effective as shown on page 7.
3. When connectors to different specifications are intermated (e.g. BS 9522 FOO 17 and MIL-C-26482), the combination must not be operated under conditions more severe than the less stringent clause of either specification.

Amphenol 62GB connectors are designed to meet the most stringent requirements of both specifications.

Military Specifications

British Standards Specification BS 9522 FOO 17 closely corresponds to the United States Military Specification MIL-C-26482 solder terminations. Certain differences exist between the schedules which can be seen on pages 2 and 3.

Approved gauges are used to check interchangeability of 62GB series with other connectors manufactured to BS 9522 FOO 17 or MIL-C-26482.

Basic Construction

62GB Series can be supplied in brass or stainless steel.

The normal shell finish used, which has a high resistance to corrosion, is zinc cobalt olive drab. Other finishes may be supplied to special order, such as cadmium plate which is available by adding deviation (714) to the end of part number.

Inserts are of polychloroprene rubber compounded to an Amphenol specification. Operating temperature range is -55°C to 125°C, and the connectors have gold-plated contacts designed for soldered connections. Configurations for size 20 contacts range between 2 contacts in the size 8 12.7mm (0.5in diameter) shell up to a maximum of 61 contacts in the size 2436.1 mm (1.5in diameter) shell. Intermediate sizes, and contact data for heavier current ratings are shown in the insert availability chart on page 6 and 7.

Hermetic connectors with glass sealed dielectric are manufactured with mild steel shells and nickel iron contacts plated tin over copper.

* Other finishes are available on request.

Protection Against Mis-Mating or Cross-Plugging

In BS 9522 FOO 17 positive shell-to-shell keying is provided with keys and keyways in a choice of either the normal (N) or any of the four preferred alternate positions: B, C, E and F. This prevents mismating between shells of different orientations and overcomes the difficulties associated with rotated inserts and a standard key-keyway orientation. In the latter system, damage to the inserts or contacts can result if excessive force is used to engage non-mating pairs.

Rotated inserts are, however, permissible in BS 9522 FOO 17 connectors if required to mate with or replace units to MIL-C-26482 mounted in existing equipment. Connectors have normal orientations manufactured to BS 9522 FOO 17 or MIL-C-26482 are fully intermateable as also are connectors with inserts in positions W, X, Y or Z.

Schedule of Tests Required for Qualification Approval







Tests	Brief Description
Visual Examination	
Dimensions, outline mass(including contacts) Compatability Gauging procedure	
Polarization	
Engaging and separating force, connector	Engagement max: 0,90 Nm (8.0 lbf.in.) to 4,97 Nm (44 lbf.in.) according to shell size. Separation min: 0,22 Nm (2.0 lbf.in.) to 1,58 Nm (14.0 lbf.in.) according to shell size.
Contact Holding Force	0,21 N (0.047 lbf) min.size 20 0,56 N (0.126 lbf)min. size 16
Sealing (air pressure)	Max leakage 28,53 uNm/s (1 cm ³ /h), 1 bar (14.5 p.s.i.) differential.
Sealing Hermetic	Hermetic receptacles have a max leak of 0.1 micron cubic foot per hour (1 x 10 ⁻⁶ Cm ³ /s)
Contact Resistance	5 milliohms max.
Housing (Shell) Continuity	200 milliohms max. 5 milliohms max. grounding spring styles.
Insulation Resistance	5,000 Megaohms at 500 - 50 V d.c.
Voltage Proof	See page 7. Duration 1 minute
Soldering	As BS 9520: 1974, Clause 1.2.6.6, Method 2.
Bumping	As BS 9520: 1974, Clause 1.2.6.1. 4,000 -10 bumps / 390m / s ² (40 gn).
Vibration	As BS 9520: 1974, Clause 1.2.6.2.1. Procedure A. 10 Hz to 5000 Hz, 0.75 mm / 10 gn.
Shock	As BS 9520: 1974, Clause 1.2.6.3. 981 m/s ² (100 g n).
Acceleration (Steady State)	As BS 9520: 1974, Clause 1.2.6.4. 490 m/s ² (50 gn).
Rapid Change of Temperature	As BS 9520: 1974, Clause 1.2.6.7. -550 C to - 1250 C.
Climatic Sequence	As BS 9520: 1974, Clause 1.2.6.11. Severity 55/125/56.
Flammability	As BS 9520: 1974, Clause 1.2.6.8. Direct flame applied, duration 1 minute.
Damp Heat (Steady State)	As BS 9520: 1974, Clause 1.2.6.14. Severity 56 days.

Schedules of Tests Required for Qualification Approval

Tests	Brief Description
Immersion (at low air pressure)	3 cycles at 30 mins each cycle, total immersion in water at pressure 44 m bar.
Mechanical Endurance	500 operations minimum
High Temperature Endurance	Long term: 1,000 hrs. at 85°C ambient carrying the specified current. Short term: 250 hrs at 125 ^o C, no current.
Mould Growth	As BS 9520: 1983, Clause 1.2.6.16. 28 days duration.
Salt Mist	As BS 9520: 1983, Clause 1.2.6.17. Severity 1.
Dust	As BS 9520: 1983, Clause 1.2.6.18 Exposure 30 minutes.
Robustness of Terminations	44,5 N (101bf) size 16 22,2 N (5 lbf) size 20
Contact Retention (in insert)	67,0 N (15 lbf) min. size 20 112,0 N (25 lbf) min. size 16
Insert Retention (in shell)	517 KN1m2 (751bf/in2) min.
Test Prod Damage	Moment: 0,056 Nm (0.5 lbf in) size 20 0,225 Nm (2 lbf in) size 16
Impact	Five impacts, drop height 1 m (3ft.3 in.).
Grounding Spring Holding Force Plugs with grounding springs only.	1,17 N (0.263 lbf) to 2,74 N (0.616 lbf) according to size.
Fluid Resistance	Immersion in 4 solvents and 9 fluids including aircraft fuels, lubricating oils and hydraulic fluids.
Compass Safe Distance	As BS 9520: 1974, Clause 1.2.5.11. 127 mm (5.0 in) min.

Accessories

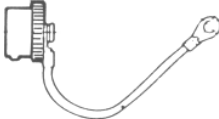
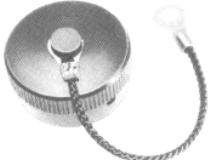
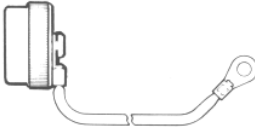
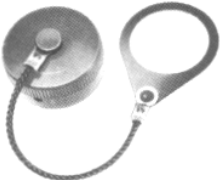
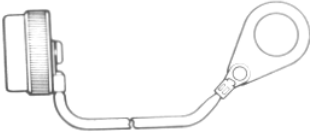





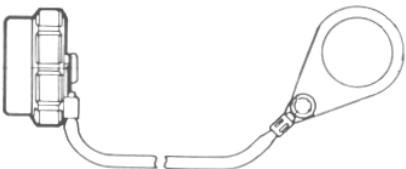
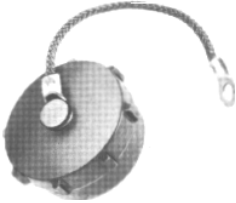

Table of Styles

			Page No.
62GB-736			42
62GB-737			42
62GB-738			43
62GB-742			43
62GB-810			44
62GB-812			44
62GB-813			45

Accessories

Table of Styles

Page No.

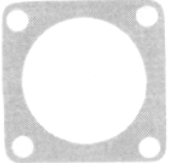
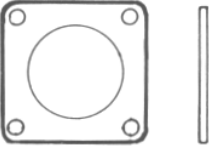
62GB-814			45
62GB-997			46
62GB-998			46
62GB-1069			47
62GB-1070			47
62GB-760			48

Accessories

736



62GB-736

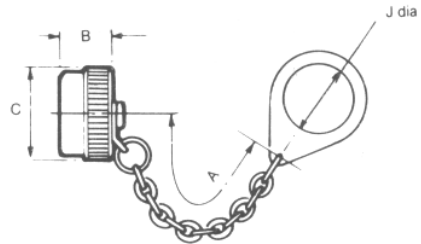

Caps and chains for single hole mounting receptacles

Shell Size	A ± 0.25 (± 6.35)	B ± 0.005 (± 0.13)	C dia max	J ± 0.005 (± 0.127)
08	3.0	0.521	0.734	0.578
	76.2	13.23	18.64	14.68
10	3.0	0.521	0.859	0.703
	76.2	13.23	21.82	17.86
12	3.5	0.521	1.000	0.891
	88.9	13.23	25.4	22.63
14	3.5	0.521	1.125	1.016
	88.9	13.23	28.57	25.81
16	3.5	0.521	1.250	1.141
	88.9	13.23	31.75	29.39
18	3.5	0.521	1.375	1.266
	88.9	13.23	34.92	32.16
20	4.0	0.521	1.500	1.391
	101.6	13.23	38.1	35.33
22	4.0	0.521	1.625	1.516
	101.6	13.23	41.27	38.51
24	4.0	0.556	1.750	1.641
	101.6	14.12	44.45	41.68

737



62GB-737

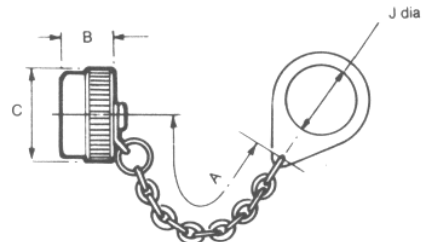

Caps and chains for cable mounting receptacles.

Shell Size	A ± 0.25 (± 6.35)	B ± 0.005 (± 0.13)	C dia max	J ± 0.005 (± 0.127)
08	3.0	0.521	0.734	0.458
	76.2	13.23	18.64	11.63
10	3.0	0.521	0.859	0.583
	76.2	13.23	21.82	14.81
12	3.5	0.521	1.000	0.708
	88.9	13.23	25.4	17.98
14	3.5	0.521	1.125	0.896
	88.9	13.23	28.57	22.76
16	3.5	0.521	1.250	1.021
	88.9	13.23	31.75	25.93
18	3.5	0.521	1.375	1.146
	88.9	13.23	34.92	29.11
20	4.0	0.521	1.500	1.271
	101.6	13.23	38.1	32.28
22	4.0	0.521	1.625	1.396
	101.6	13.23	41.27	35.46
24	4.0	0.556	1.750	1.521
	101.6	14.12	44.45	38.63

Accessories

738



62GB-738

Caps and chains for flange mounting receptacles.

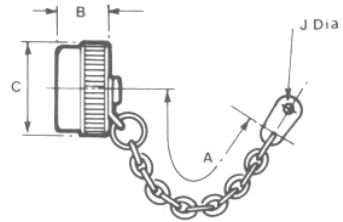

Shell Size	A ± 0.25 (± 6.35)	B ± 0.005 (± 0.13)	C dia max	J ± 0.005 (± 0.127)
08	3.0	0.521	0.734	0.125
	76.2	13.23	18.64	3.18
10	3.0	0.521	0.859	0.125
	76.2	13.23	21.82	3.18
12	3.5	0.521	1.000	0.125
	88.9	13.23	25.4	3.18
14	3.5	0.521	1.125	0.125
	88.9	13.23	28.57	3.18
16	3.5	0.521	1.250	0.125
	88.9	13.23	31.75	3.18
18	3.5	0.521	1.375	0.125
	88.9	13.23	34.92	3.18
20	4.0	0.521	1.500	0.125
	101.6	13.23	38.1	3.18
22	4.0	0.521	1.625	0.125
	101.6	13.23	41.27	3.18
24	4.0	0.556	1.750	0.152
	101.6	14.12	44.45	3.86

742



62GB-742

Caps and chains for plugs.

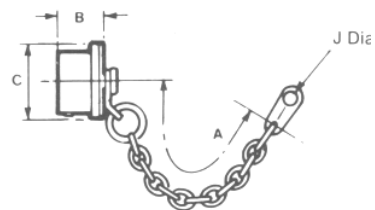

Shell Size	A ± 0.25 (± 6.35)	B ± 0.005 (± 0.13)	C dia max	J ± 0.005 (± 0.127)
08	3.0	0.522	0.719	0.125
	76.2	13.25	18.26	3.18
10	3.0	0.522	0.844	0.125
	76.2	13.25	21.43	3.18
12	3.5	0.522	1.000	0.125
	88.9	13.25	25.4	3.18
14	3.5	0.522	1.125	0.125
	88.9	13.25	28.57	3.18
16	3.5	0.522	1.250	0.125
	88.9	13.25	31.75	3.18
18	3.5	0.522	1.357	0.125
	88.9	13.25	34.92	3.18
20	4.0	0.584	1.500	0.125
	101.6	14.83	38.1	3.18
22	4.0	0.584	1.625	0.125
	101.6	14.83	41.27	3.18
24	4.0	0.617	1.750	0.152
	101.6	15.67	44.45	3.86

Accessories

810



62GB-810
BS9522-F0017-A2012

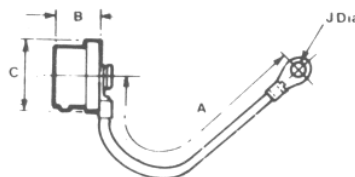

Caps and cords for plugs

Shell Size	A ± 0.25 (± 6.35)	B ± 0.005 (± 0.13)	C dia max	J ± 0.003 (± 0.08)
08	3.0 76.2	0.522 13.25	0.719 18.26	0.145 3.68
10	3.0 76.2	0.522 13.25	0.844 21.43	3.685 3.68
12	3.5 88.9	0.522 13.25	1.000 25.4	0.145 3.68
14	3.5 88.9	0.522 13.25	1.125 28.57	0.145 3.68
16	3.5 88.9	0.522 13.25	1.250 31.75	0.145 3.68
20	4.0 101.6	0.584 14.83	1.500 38.1	0.145 3.68
22	4.0 101.6	0.584 14.83	1.625 41.27	0.145 3.68
24	4.0 101.6	0.617 15.67	1.750 44.45	0.171 4.34

812

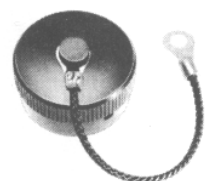

62GB-812
BS9522-F0017-A2013

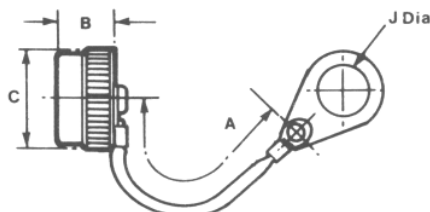

Caps and cords for flange mounting receptacles.

Shell Size	A ± 0.25 (± 6.35)	B ± 0.005 (± 0.13)	C dia max	J ± 0.003 (± 0.08)
08	3.0 76.2	0.521 13.23	0.734 18.64	0.145 3.68
10	3.0 76.2	0.521 13.23	0.859 21.82	0.145 3.68
12	3.5 88.9	0.521 13.23	1.000 25.4	0.145 3.68
14	3.5 88.9	0.521 13.23	1.125 28.57	0.145 3.68
16	3.5 88.9	0.521 13.23	1.250 31.75	0.145 3.68
18	3.5 88.9	0.521 13.23	1.375 34.92	0.145 3.68
20	4.0 101.6	0.521 13.23	1.500 38.1	0.145 3.68
22	4.0 101.6	0.521 13.23	1.625 41.27	0.145 3.68
24	4.0 101.6	0.556 14.12	1.750 44.45	0.171 4.34

Accessories

813



62GB-813
BS9522-F0017 A2014

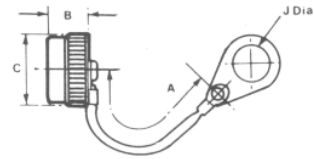

Caps and cords for single hole mounting receptacles.

Shell Size	A ± 0.25 (± 6.35)	B ± 0.005 (± 0.13)	C max	J + 0.010 (+ 0.25)
08	3.0	0.521	0.734	0.578
	76.2	13.23	18.64	14.68
10	3.0	0.521	0.859	0.703
	76.2	13.23	21.82	17.86
12	3.5	0.521	1.000	0.891
	88.9	13.23	25.4	22.63
14	3.5	0.521	1.125	1.016
	88.9	13.23	28.57	25.81
16	3.5	0.521	1.250	1.141
	88.9	13.23	31.75	29.39
18	3.5	0.521	1.375	1.266
	88.9	13.23	34.92	32.16
20	4.0	0.521	1.500	1.391
	101.6	13.23	38.1	35.33
22	4.0	0.521	1.625	1.516
	101.6	13.23	41.27	38.56
24	4.0	0.556	1.750	1.641
	101.6	14.12	44.45	41.68

814



62GB-814

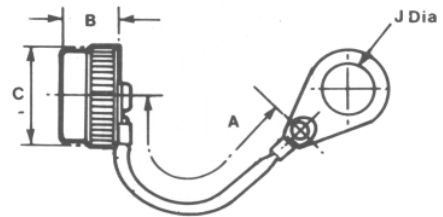

Caps and cords for cable mounting receptacles.

Shell Size	A ± 0.25 (± 6.35)	B ± 0.005 (± 0.13)	C max	J +0.010 (+ 0.25)
08	3.0	0.521	0.734	0.453
	76.2	13.23	18.64	11.50
10	3.0	0.521	0.859	0.578
	76.2	13.23	21.82	14.64
12	3.5	0.521	1.000	0.703
	88.9	13.23	25.4	17.85
14	3.5	0.521	1.125	0.891
	88.9	13.23	28.57	22.63
16	3.5	0.521	1.250	1.016
	88.9	13.23	31.75	25.80
18	3.5	0.521	1.375	1.141
	88.9	13.23	34.92	28.98
20	4.0	0.521	1.500	1.266
	101.6	13.23	38.1	32.15
22	4.0	0.521	1.625	1.391
	101.6	13.23	41.27	35.33
24	4.0	0.556	1.750	1.516
	101.6	14.12	44.45	38.50

Accessories

997



62GB-997

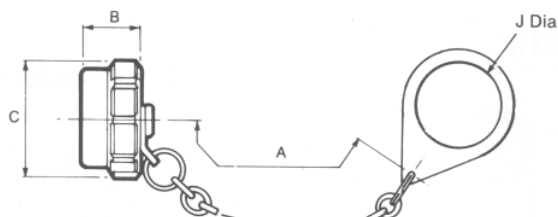

Caps and chains ribbed for single hole mounting receptacles.

Shell Size	A ± 0.25 (± 6.35)	B ± 0.005 (± 0.13)	C dia max	J + 0.010 (+ 0.25)
08	3.0 76.2	0.521 13.23	0.892 22.66	0.578 14.69
10	3.0 76.2	0.521 13.23	1.017 26.84	0.703 17.86
12	3.5 88.9	0.521 13.23	1.142 29.01	0.891 22.64
14	3.5 88.9	0.521 13.23	1.267 32.19	1.016 25.81
16	3.5 88.9	0.521 13.23	1.454 36.94	1.141 28.99
18	3.5 88.9	0.521 13.23	1.563 39.70	1.266 32.16
20	4.0 101.6	0.521 13.23	1.687 42.85	1.391 35.34
22	4.0 101.6	0.521 13.23	1.797 45.65	1.516 38.51
24	4.0 101.6	0.556 14.12	1.922 48.82	1.641 41.69

998



62GB-998

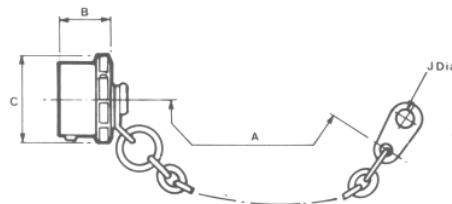

Caps and chains ribbed for plugs.

Shell Size	A ± 0.25 (± 6.35)	g max	C dia max	J ± 0.005 (± 0.13)
08	3.0 76.2	0.562 14.28	0.892 22.66	0.125 3.18
10	3.0 76.2	0.562 14.28	1.017 25.84	0.125 3.18
12	3.5 88.9	0.562 14.28	1.142 29.01	0.125 3.18
14	3.5 88.9	0.562 14.28	1.267 32.19	0.125 3.18
16	3.5 88.9	0.562 14.28	1.454 36.94	0.125 3.18
18	3.5 88.9	0.562 14.28	1.563 39.70	0.125 3.18
20	4.0 101.6	0.624 15.85	1.687 42.85	0.125 3.18
22	4.0 101.6	0.624 15.85	1.797 45.65	0.125 3.18
24	4.0 101.6	0.624 15.85	1.922 48.82	0.147 3.74

Accessories



1069

62GB-1069

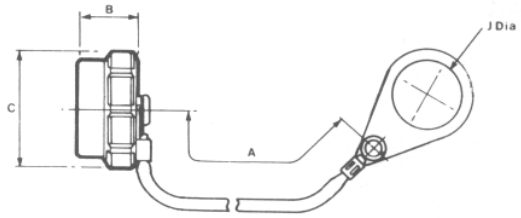

Caps and cords ribbed for single hole mounting receptacles.

Shell Size	A ± 0.25 (± 6.35)	B ± 0.005 (± 0.13)	C dia max	J + 0.010 (+ 0.25)
08	3.0	0.521	0.892	0.578
	76.2	13.23	22.66	14.69
10	8.0	0.521	1.017	0.703
	76.2	13.23	26.84	17.86
12	3.5	0.521	1.142	0.891
	88.9	13.23	29.01	22.64
14	3.5	0.521	1.267	1.016
	88.9	13.23	32.19	25.81
16	3.5	0.521	1.454	1.141
	88.9	13.23	36.94	28.99
18	3.5	0.521	1.563	1.266
	88.9	13.23	39.70	32.16
20	4.0	0.521	1.687	1.391
	101.6	13.23	42.85	35.34
22	4.0	0.521	1.797	1.516
	101.6	13.23	45.65	38.51
24	4.0	0.556	1.922	1.641
	101.6	14.12	48.82	41.686

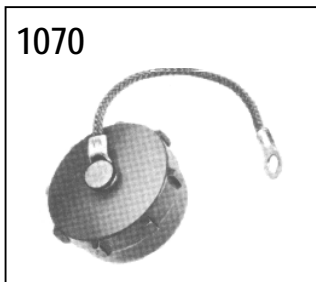

1070

62GB-1070

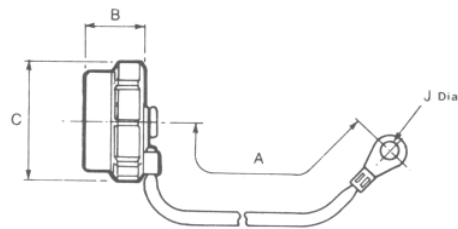

Caps and cords ribbed for flange mounting receptacles.

Shell Size	A ± 0.25 (± 6.35)	B ± 0.005 (± 0.13)	C Dia max	J ± 0.005 (± 0.13)
08	3.0	0.521	0.892	0.117
	76.2	13.23	22.66	3.03
10	3.0	0.521	1.017	0.119
	76.2	13.23	22.66	3.03
12	3.5	0.521	1.142	0.119
	88.9	13.23	29.01	3.03
14	3.5	0.521	1.267	0.119
	88.9	13.23	32.19	3.03
16	3.5	0.521	1.454	0.119
	88.9	13.23	36.94	3.03
18	3.5	0.521	1.563	0.119
	88.9	13.23	39.70	3.03
20	4.0	0.521	1.687	0.119
	101.6	13.23	42.85	3.03
22	4.0	0.521	1.797	0.119
	101.6	13.23	45.65	3.03
24	4.0	0.556	1.922	0.147
	101.6	14.12	48.82	3.74

Accessories

760

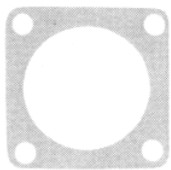

62GB-760

Flange mounting gasket for box mounting and hermetic receptacles.

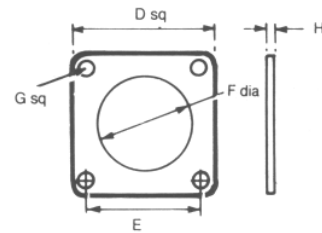











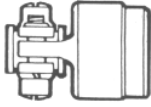

Shell Size	0 ± 0.010 (± 0.254)	E ± 0.010 (± 0.254)	F ± 0.008 (± 0.20)	G + 0.010 (+ 0.254)	H
08	0.812	0.594	0.508	0.130	0.042 / 0.016
	20.62	15.08	12.90	3.30	1.06 / 0.40
10	0.938	0.719	0.633	0.130	0.042 / 0.016
	23.82	18.26	16.07	3.30	1.06 / 0.40
12	1.031	0.813	0.758	0.130	0.042 / 0.016
	26.18	20.65	19.25	3.30	1.06 / 0.40
14	1.125	0.906	0.883	0.130	0.042 / 0.016
	28.57	23.01	22.42	3.30	1.06 / 0.40
16	1.219	0.969	1.008	0.130	0.042 / 0.016
	30.96	24.61	25.60	3.30	1.06 / 0.40
18	1.312	1.063	1.133	0.130	0.042 / 0.016
	33.32	27.00	28.77	3.30	1.06 / 0.40
20	1.438	1.156	1.258	0.130	0.042 / 0.016
	36.52	29.36	31.95	3.30	1.06 / 0.40
22	1.563	1.250	1.383	0.130	0.042 / 0.016
	39.70	31.75	35.13	3.30	1.06 / 0.40
24	1.688	1.375	1.508	0.156	0.042 / 0.016
	42.87	34.92	38.30	3.96	1.06 / 0.40

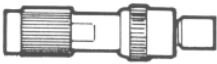
Cable Accessories

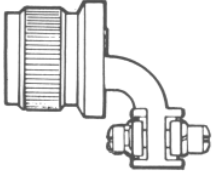
Table of Styles

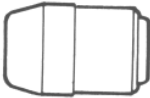

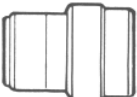
Page No.

62GB-584			51
62GB-585			51
62GB-586			52
62GB-587			52
62GB-711			53
62GB-720			53
62GB-776			54

Cable Accessories

Table of Styles

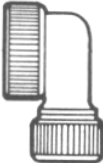
Page No.

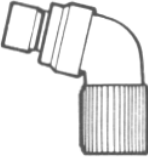
62GB-1225			54
62GB-5028			55

Cable Accessories



584

62GB - 584 - XX - XXS or P
BS 9522 FOO 17 A2102

Grommet seal and nut. Provides an environmental seal for the exposed solder buckets in the openback class T shells.

Suffix XX - XXS or P enables grommet to be matched to the insert arrangement.

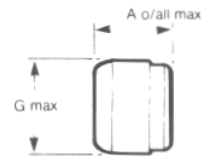

Shell Size	A	G max
08	0.545	0.561
	13.84	14.25
10	0.545	0.686
	13.84	17.43
12	0.545	0.811
	13.84	20.60
14	0.545	0.936
	13.84	23.78
16	0.545	1.061
	13.84	26.95
18	0.545	1.186
	13.84	30.13
20	0.545	1.311
	13.84	33.30
22	0.545	1.436
	13.84	36.75
24	0.501	1.561
	12.73	39.65



585

62G B - 585 - XX - XXS or P
BS9522 FOO 17 A2103

Grommet and nut with strain relief clamp. The clamp prevents the flexing of the wires in the immediate vicinity of the risers, so avoiding the risk of leaks.

Suffix XX - XXS or P enables grommet to be matched to the insert arrangement.

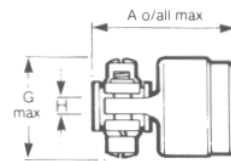

Shell Size	A max	G max	max
08	0.991	0.828	0.161
	25.17	21.03	4.09
10	0.991	0.891	0.193
	25.17	22.63	4.90
12	0.991	1.016	0.317
	25.17	25.81	8.05
14	0.965	1.141	0.380
	24.51	28.98	9.65
16	1.105	1.203	0.505
	28.07	30.56	12.83
18	1.105	1.426	0.630
	28.07	36.22	16.00
20	1.285	1.426	0.630
	32.64	36.22	16.00
22	1.285	1.567	0.755
	32.64	39.80	19.18
24	1.373	1.735	0.805
	34.88	44.07	20.45

Cable Accessories



62G B - 586 - XX

Potting mould and ring, supplied together as a set.

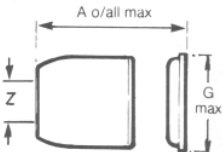

Suffix XX specifies shell size.

Shell Size	A max	G max	Z min
08	0.644	0.585	0.260
	16.36	14.85	6.60
10	0.753	0.679	0.463
	19.13	17.24	11.76
12	0.722	0.835	0.557
	18.34	21.20	14.14
14	0.722	0.913	0.590
	18.34	23.19	14.98
16	0.722	1.038	0.713
	18.34	26.36	18.11
18	0.722	1.163	0.835
	18.34	29.54	21.20
20	0.877	1.288	1.015
	22.30	32.71	25.78
22	0.877	1.413	1.015
	22.30	35.89	25.78
24	0.896	1.538	1.263
	22.76	39.06	32.08



62G B - 587 - XX - XXS or P

Clamp for screened jacketed cable. 62 Series only with grommet. Effective sealing is provided over the range of cables covered by DEF 10(Pattern C) and DEF STAN 61-12 port (see table). These are supplied to separate order only for use with style T shells.

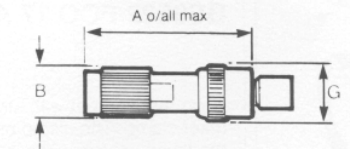

Suffix XX-XXS or P enables grommet to be matched to the insert arrangement.

Shell Size	length Including plug	A Max	length Including receptacle	B max	G max
08	2.732	2.742	2.742	0.676	0.775
	69.39	69.64	69.64	17.17	19.68
10	2.742	2.752	2.752	0.676	0.902
	69.64	69.90	69.90	17.17	22.91
12	3.152	3.162	3.162	0.812	1.030
	80.06	80.31	80.31	20.62	26.16
14	3.152	3.162	3.162	0.926	1.157
	80.06	80.31	80.31	23.52	29.39
16	3.272	3.282	3.282	1.051	1.284
	83.10	83.36	83.36	26.67	32.61
18	-	-	-	-	-
	3.272	3.345	3.345	1.280	1.539
20	83.10	84.96	84.96	32.51	39.09
	-	-	-	-	-
22	-	-	-	-	-
	3.696	3.768	3.768	1.620	1.783
24	93.87	95.70	95.70	41.15	45.29

Cable Accessories

711



62G B - 711 - XX - XXS or P

Grommet and nut with right angled strain relief clamp. The clamp prevents flexing of the wires in the immediate vicinity of the risers, so avoiding the risk of leaks (these are supplied to separate order only for use with style T shells).

Suffix XX - XXS or P enables grommet to be matched to the insert arrangement.

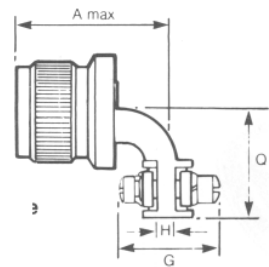

Shell Size	A max	G max	H ± 0.005 ± 0.13	Q max
08	1.5/32	0.828	0.161	0.733
		21.03	4.09	18.62
10	1.3/16	0.891	0.193	0.795
		22.63	4.90	20.19
12	1.7/32	1.016	0.317	0.858
		25.81	8.05	21.79
14	1.1/4	1.141	0.380	0.915
		28.98	9.65	23.24
16	1.5/16	1.203	0.505	1.010
		30.56	12.83	25.65
18	1.3/8	1.426	0.630	1.070
		36.22	16.00	27.18
20	1.3/8	1.426	0.630	1.140
		36.22	16.00	28.96
22	1.29/64	1.567	0.755	1.170
		39.80	19.18	29.72
24	1.15/32	1.735	0.805	1.260
		44.07	20.45	32.00

720

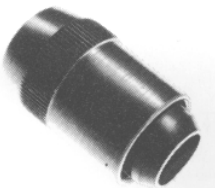

62G B - 720 - XX

Clamp for unscreened jacketed cable. No grommet is supplied, for use with 50T, 51T and 56T styles.

Suffix XX specifies shell size.

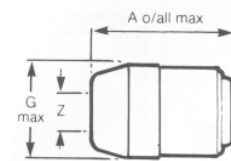

Shell Size	A max	G max	Z closed	Z free
08	1.085	0.561	0.168	0.230
	27.56	14.25	4.28	5.84
10	1.060	0.686	0.205	0.312
	26.92	17.43	5.21	7.93
12	1.160	0.811	0.338	0.442
	29.46	20.60	8.59	11.23
14	1.360	0.936	0.416	0.539
	34.54	23.78	10.57	13.69
16	1.585	1.061	0.550	0.616
	40.26	26.95	13.97	15.65
18	1.785	1.186	0.600	0.672
	45.34	30.13	15.24	17.57
20	1.981	1.311	0.635	0.747
	50.32	33.30	16.13	18.98
22	2.181	1.436	0.670	0.846
	55.39	36.75	17.02	21.49
24	2.216	1.561	0.740	0.894
	56.28	39.65	18.80	22.71

Cable Accessories

776



62GB - 776

General duty shell to accept conduit, AN 3057 or MS 3057 A cable clamps and heat shrink sleeves.

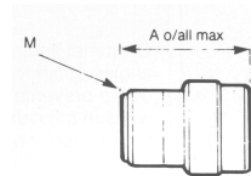

Shell Size	A max	M Thread
08	0.937 23.80	1/2 - 28 UNEF
10	0.937 23.80	5/8 - 24 NEF
12	0.937 23.80	3/4 - 20 UNEF
14	0.937 23.80	7/8 - 20 UNEF
16	0.937 23.80	1 - 20 UNEF
18	0.937 23.80	1.3/16 - 18 NEF
20	0.937 23.80	1.3/16 - 18 NEF
22	0.937 23.80	1.7/16 - 18 NEF
24	0.937 23.80	1.7/16 - 18 NEF

1225

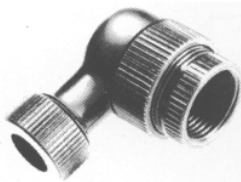

62GB - 1225

90° clamp for screened jacketed cable. These are supplied to separate order only for use with style T shells.

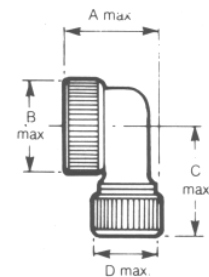

Shell Size	A max	B max	C max	D max
08	0.942 23.93	0.821 20.85	1.160 29.46	0.636 16.15
10	0.883 22.43	0.821 20.85	1.160 29.46	0.636 16.15
12	0.704 17.88	0.821 20.85	1.160 29.46	0.636 16.15
14	1.119 28.42	0.937 23.80	1.160 29.46	0.636 16.15

Cable Accessories

5028

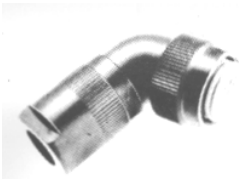

62G B - 5028 - XX - XXS or P

75% Clamp for screened jacketed cable with grommet. Effective sealing is provided over the range of cables covered by DEF 10 (Pattern C) and DEF STAN 61 - 12 part 5 (see table). These are supplied to separate order only and are intended for use with style T shells.

Suffix XX-XXS or P enables grommet to be matched to the insert arrangement.

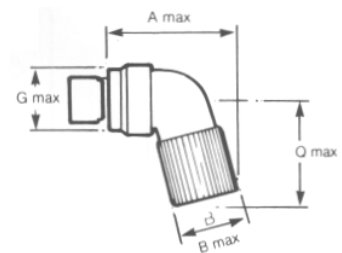

Shell Size	length including receptacle	A Max	length including plug	B max	G max	max
08	2.416		2.375	0.676	0.775	1.750
	61.37		60.24	17.17	19.68	44.45
10	2.573		2.532	0.676	0.902	1.875
	65.35		64.39	17.17	22.91	47.63
12	2.666		2.625	0.812	1.030	2.125
	67.72		66.68	20.62	26.16	53.98
14	2.760		2.719	0.926	1.157	2.125
	70.10		69.04	23.52	29.39	53.98
16	2.790		2.750	1.051	1.284	2.062
	70.87		69.80	26.70	32.61	52.38
18	-		-	-	-	-
	-		-	-	-	-
20	3.312		3.250	1.280	1.539	2.062
	84.13		82.55	32.51	39.09	52.38
22	-		-	-	-	-
	-		-	-	-	-
24	3.500		3.375	1.620	1.783	2.187
	88.90		85.73	41.15	45.29	55.55

X-ON Electronics

Largest Supplier of Electrical and Electronic Components

Click to view similar products for [amphenol manufacturer](#):

Other Similar products are found below :

[10-507142-843](#) [GTS02R20-15P-025-116](#) [ACC02E28-51S-003-B30-LC](#) [TV06RL-13-35SD-LC](#) [TV06RL-13-35SD](#) [TV06RL-13-98SD-LC](#)
[TV06RL-13-98SD](#) [TVP00RW-23-53AD](#) [100-007-213-002-001](#) [TV06RW-25-90AE](#) [97-3108B16S-5PW-417](#) [PT06J20-24SW](#) [97-3108B16S-4PY-417](#) [97-3108B16S-4PX-417](#) [97-3108B16S-5PY-417](#) [97-3108B16S-4PW-417](#) [CS-DSDMDB37MF-025](#) [97-3108B16S-5PZ-417](#)
[TV06RW-25-46AE](#) [TVS07RF-21-16AA](#) [TVS07RF-21-39BA](#) [GTC02R32-17S-025-RDS](#) [GTC06-22-13SW](#) [GTC06-22-13SX-025-B30](#)
[GTC06-22-13SW-025-B30](#) [GTC06-22-13SW-025-B30-LC](#) [GTC06-22-13SX-025-LC](#) [GTC06-22-13SY-025-B30-LC](#) [GTC06-22-13SY-025-LC](#) [97-3101A20-21P-958](#) [97-3106A18-3PX-958](#) [97-3106A18-3PY-958](#) [GTC06-36-7S-LC](#) [GTS08-36-22PZ-025-B30](#) [CTV07RW-11-99AD](#)
[PT00SP2241P](#) [GTS01-16-10S-116](#) [TVS07RF-25-43AB](#) [GTS030A20-4S-025-116](#) [GTS030A20-4SW-025-116](#) [GTS030A20-4SX-025-116](#)
[LJT06RT-15-35PB\(023\)](#) [LJT06RT-15-68PB-023](#) [GTS030A20-4SY-025-116](#) [JTP02RE-16-55P\(023\)](#) [TVS07RF-21-11BA](#) [PT06A14-4S-005](#)
[TVS06RF-17-99BD](#) [97-3106A-22-9S\(621\)](#) [GTC06-22-13S-025-B30-LC](#)