

**Single Overall  
 EMI/RFI  
 Shield  
 Termination**

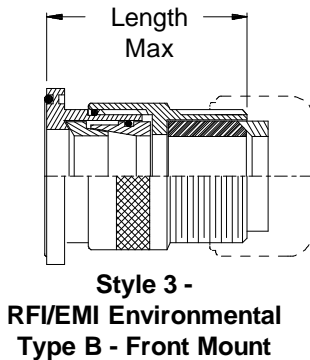

1. Metric dimensions (mm) are indicated in parentheses.
2. Cable range is defined as the accommodations range for the wire bundle or cable. Dimensions shown are not intended for inspection criteria.

**STYLE H**  
 Heavy Duty

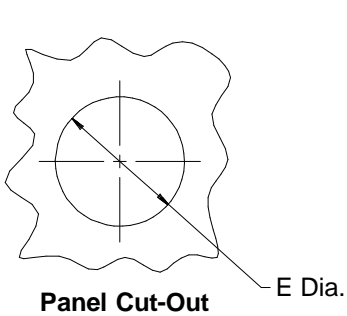
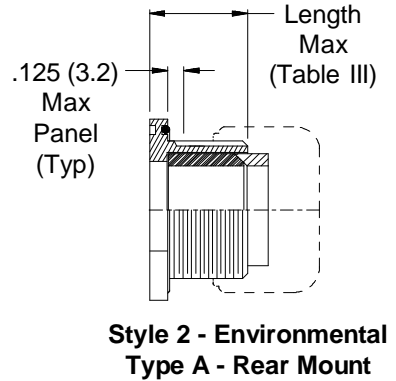
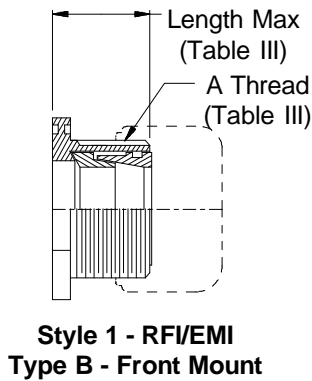
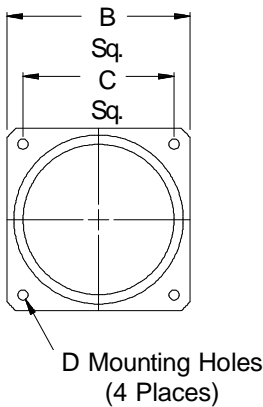
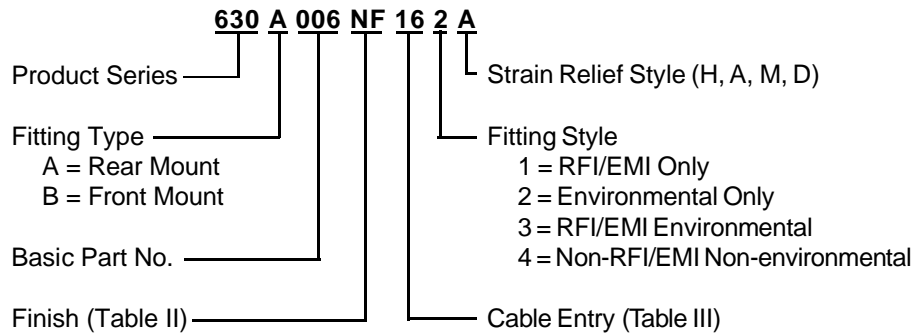
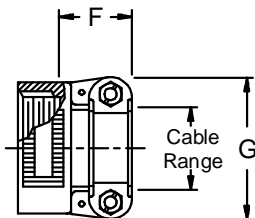

**STYLE A**  
 Medium Duty

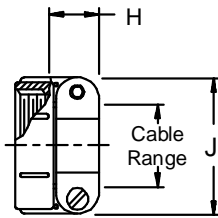

**STYLE M**  
 Medium Duty

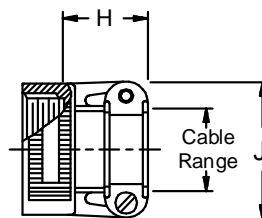

**STYLE D**  
 Medium Duty

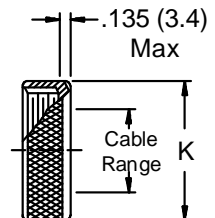

**630-006**  
**EMI/RFI Environmental Bulkhead Feed-Through**  
 with Strain Relief  
 Front and Rear Panel Mount - Straight



See inside back cover fold-out or page 14 for Table II.

**TABLE III: CABLE ENTRY**

Dash No.	Clamp Style	Clamp Size	Cable Range		A Thread		B		C Sq.		D Dia -.000	E Dia -.000
			Min	Max	Unified	Dim	±.010	(±.3)	+ .015 (+ .4)	+ .030 (+.8)		
01	1, 2	03	.157 (4.0)	.250 (6.4)	1/2-28	.885 (22.5)	.593 (15.1)	.120 (3.0)	.250 (6.4)			
02	3	03	.157 (4.0)	.250 (6.4)	1/2-28	.885 (22.5)	.593 (15.1)	.120 (3.0)	.250 (6.4)			
03	1,2	04	.187 (4.7)	.312 (7.9)	5/8-24	1.104 (28.0)	.812 (20.6)	.120 (3.0)	.312 (7.9)			
04	3	04	.187 (4.7)	.312 (7.9)	5/8-24	1.104 (28.0)	.812 (20.6)	.120 (3.0)	.312 (7.9)			
05	1, 2	06	.281 (7.1)	.437 (11.1)	3/4-20	1.197 (30.4)	.906 (23.0)	.120 (3.0)	.437 (11.1)			
06	3	06	.281 (7.1)	.437 (11.1)	3/4-20	1.197 (30.4)	.906 (23.0)	.120 (3.0)	.437 (11.1)			
07	1,2	08	.344 (8.7)	.562 (14.3)	7/8-20	1.291 (32.8)	.968 (24.6)	.120 (3.0)	.562 (14.3)			
08	3	08	.344 (8.7)	.562 (14.3)	7/8-20	1.291 (32.8)	.968 (24.6)	.120 (3.0)	.562 (14.3)			
09	1, 2	10	.375 (9.5)	.625 (15.9)	1-20	1.385 (35.2)	1.062 (27.0)	.120 (3.0)	.625 (15.9)			
10	3	10	.375 (9.5)	.625 (15.9)	1-20	1.385 (35.2)	1.062 (27.0)	.120 (3.0)	.625 (15.9)			
11	1,2	12	.438 (11.1)	.750 (19.1)	1 3/16-18	1.635 (41.5)	1.250 (31.8)	.120 (3.0)	.750 (19.1)			
12	3	12	.438 (11.1)	.750 (19.1)	1 3/16-18	1.635 (41.5)	1.250 (31.8)	.120 (3.0)	.750 (19.1)			
13	1, 2	16	.625 (15.9)	.937 (23.8)	1 7/16-18	1.760 (44.7)	1.375 (34.9)	.147 (3.7)	.937 (23.8)			
14	3	16	.625 (15.9)	.937 (23.8)	1 7/16-18	1.760 (44.7)	1.375 (34.9)	.147 (3.7)	.937 (23.8)			
15	1,2	20	.875 (22.2)	1.250 (31.8)	1 3/4-18	2.010 (51.1)	1.562 (39.7)	.147 (3.7)	1.250 (31.8)			
16	3	20	.875 (22.2)	1.250 (31.8)	1 3/4-18	2.010 (51.1)	1.562 (39.7)	.147 (3.7)	1.250 (31.8)			
17	1, 2	24	1.000 (25.4)	1.375 (34.9)	2-18	2.260 (57.4)	1.750 (44.5)	.173 (4.4)	1.375 (34.9)			
18	3	24	1.000 (25.4)	1.375 (34.9)	2-18	2.260 (57.4)	1.750 (44.5)	.173 (4.4)	1.375 (34.9)			
19	1,2	28	1.250 (31.8)	1.625 (41.3)	2 1/4-16	2.510 (63.8)	1.938 (49.2)	.173 (4.4)	1.625 (41.3)			
20	3	28	1.250 (31.8)	1.625 (41.3)	2 1/4-16	2.510 (63.8)	1.938 (49.2)	.173 (4.4)	1.625 (41.3)			
21	1, 2	32	1.437 (36.5)	1.875 (47.6)	2 1/2-16	2.781 (70.6)	2.188 (55.6)	.173 (4.4)	1.875 (47.6)			
22	3	32	1.437 (36.5)	1.875 (47.6)	2 1/2-16	2.781 (70.6)	2.188 (55.6)	.173 (4.4)	1.875 (47.6)			
23	1,2	40	1.875 (47.6)	2.375 (60.3)	3-16	3.281 (83.3)	2.625 (66.7)	.173 (4.4)	2.375 (60.3)			
24	3	40	1.875 (47.6)	2.375 (60.3)	3-16	3.281 (83.3)	2.625 (66.7)	.173 (4.4)	2.375 (60.3)			

**TABLE III (Continued)**

Dash No.	Style	F Max	G Max	H Max	J Max	K Max	Length Max
01	1, 2	---	---	.760 (19.3)	.843 (21.4)	.630 (16.0)	.971 (24.7)
02	3	---	---	.760 (19.3)	.843 (21.4)	.630 (16.0)	1.820 (46.2)
03	1,2	.780 (19.8)	.957 (24.3)	.760 (19.3)	.906 (23.0)	.755 (19.2)	.971 (24.7)
04	3	.780 (19.8)	.957 (24.3)	.760 (19.3)	.906 (23.0)	.755 (19.2)	1.820 (46.2)
05	1, 2	.780 (19.8)	1.145 (29.1)	.760 (19.3)	1.093 (27.8)	.942 (23.9)	.971 (24.7)
06	3	.780 (19.8)	1.145 (29.1)	.760 (19.3)	1.093 (27.8)	.942 (23.9)	1.820 (46.2)
07	1,2	.780 (19.8)	1.332 (33.8)	.760 (19.3)	1.187 (30.1)	1.067 (27.1)	.971 (24.7)
08	3	.780 (19.8)	1.332 (33.8)	.760 (19.3)	1.187 (30.1)	1.067 (27.1)	1.820 (46.2)
09	1, 2	.780 (19.8)	1.332 (33.8)	.760 (19.3)	1.281 (32.5)	1.192 (30.3)	.971 (24.7)
10	3	.780 (19.8)	1.332 (33.8)	.760 (19.3)	1.281 (32.5)	1.192 (30.3)	1.820 (46.2)
11	1,2	.811 (20.6)	1.551 (39.4)	.760 (19.3)	1.500 (38.1)	1.380 (35.1)	1.031 (26.2)
12	3	.811 (20.6)	1.551 (39.4)	.760 (19.3)	1.500 (38.1)	1.380 (35.1)	1.820 (46.2)
13	1, 2	.905 (23.0)	1.770 (45.0)	1.073 (27.3)	1.719 (43.7)	1.535 (39.0)	1.031 (26.2)
14	3	.905 (23.0)	1.770 (45.0)	1.073 (27.3)	1.719 (43.7)	1.535 (39.0)	1.820 (46.2)
15	1,2	1.092 (27.7)	2.113 (53.7)	1.323 (33.6)	2.062 (52.4)	1.848 (46.9)	1.031 (26.2)
16	3	1.092 (27.7)	2.113 (53.7)	1.323 (33.6)	2.062 (52.4)	1.848 (46.9)	1.820 (46.2)
17	1, 2	1.124 (28.5)	2.363 (60.0)	1.323 (33.6)	2.312 (58.7)	2.255 (57.3)	1.095 (27.8)
18	3	1.124 (28.5)	2.363 (60.0)	1.323 (33.6)	2.312 (58.7)	2.255 (57.3)	1.820 (46.2)
19	1,2	1.399 (35.5)	2.770 (70.4)	1.572 (39.9)	2.719 (69.1)	2.505 (63.6)	1.095 (27.8)
20	3	1.399 (35.5)	2.770 (70.4)	1.572 (39.9)	2.719 (69.1)	2.505 (63.6)	1.820 (46.2)
21	1, 2	1.399 (35.5)	3.020 (76.7)	1.572 (39.9)	2.969 (75.4)	2.755 (70.0)	1.095 (27.8)
22	3	1.399 (35.5)	3.020 (76.7)	1.572 (39.9)	2.969 (75.4)	2.755 (70.0)	1.940 (49.3)
23	1,2	---	---	1.572 (39.9)	3.531 (89.7)	3.255 (82.7)	1.220 (31.0)
24	3	---	---	1.572 (39.9)	3.531 (89.7)	3.255 (82.7)	2.060 (52.3)

## X-ON Electronics

Largest Supplier of Electrical and Electronic Components

*Click to view similar products for* [Circular MIL Spec Tools, Hardware & Accessories](#) *category:*

*Click to view products by* [Glenair](#) *manufacturer:*

Other Similar products are found below :

[809-199-3](#) [001104](#) [300 04](#) [600-006-16](#) [600-079-06](#) [M10-101982-143](#) [M10-101982-163](#) [M10-101983-183](#) [M10-150912-083](#) [M10-454396-008](#) [602GB18808](#) [M225201-06](#) [M24758-20E21](#) [M2887610-BC](#) [M2887615-CD](#) [M38999/9-19B](#) [62GB-812-10](#) [630A007NF083A](#) [630B007M051A](#) [630BJ003NF032H](#) [637-149NF04B](#) [M39029/29-215](#) [650FS002NF16](#) [M81969-14-02](#) [660-008NF14S7-01](#) [660-009M22H8-03](#) [660-013NF19U6-210](#) [660-015M10S6-17](#) [660-015NF10S5-01](#) [660-015NF14R3.5-01](#) [660-023NF19H6-19](#) [660-024N09S5-104](#) [660-024NF11S12-01](#) [660-024NF11S3-01](#) [660-050XM17F4-01](#) [660-068NF25R6-30G](#) [660-070M23S8-04](#) [660-073MTCH9-20](#) [M83723/60-116RC](#) [M83723/61-18W](#) [M83723/61-218R](#) [M83723/61-224W](#) [667-224NF16](#) [M85049/118S22A](#) [M85049/126S11N](#) [M85049130-07M](#) [M85049140-09BC](#) [M85049/41-16A W/B](#) [687-697NF-1](#) [M85049/75-14-1](#) [M8504980-8](#)