

A4988 Stepper Motor Driver Carrier with Voltage Regulators

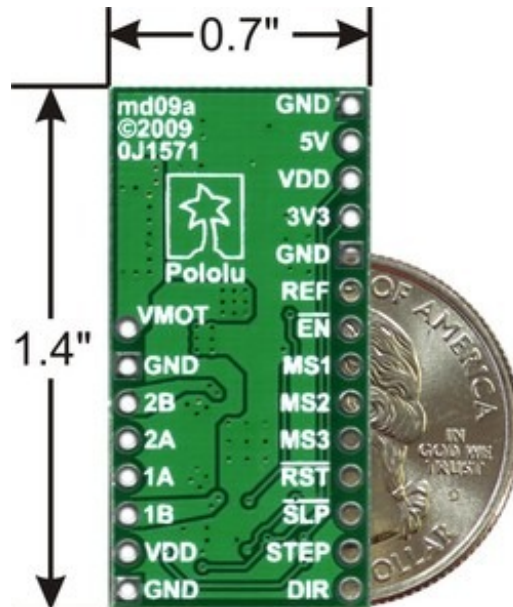

A4983/A4988 stepper motor driver carrier with voltage regulators with dimensions.

Overview

This product is a carrier board or breakout board for Allegro's A4988 DMOS Microstepping Driver with Translator and Overcurrent Protection; we therefore recommend careful reading of the A4988 datasheet (380k pdf) before using this product. This stepper motor driver lets you control one bipolar stepper motor at up to 2 A output current per coil (see the Power Dissipation Considerations section below for more information). Here are some of the driver's key features:

- **Simple step and direction control interface**
- **Five different step resolutions: full-step, half-step, quarter-step, eighth-step, and sixteenth-step**
- **Adjustable current control lets you set the maximum current output with a potentiometer, which lets you use voltages above your stepper motor's rated voltage to achieve higher step rates**
- **Intelligent chopping control that automatically selects the correct current decay mode (fast decay or slow decay)**
- **Over-temperature thermal shutdown, under-voltage lockout, and crossover-current protection**
- **Short-to-ground and shorted-load protection**

This carrier has reverse power protection on the main power input and built-in 5 V and 3.3 V voltage regulators that eliminate the need for separate logic and motor supplies and let you control the driver with microcontrollers powered at 5 V or 3.3 V. We also sell a smaller, higher-performance version of the A4988 carrier without voltage regulators.

Like nearly all our other carrier boards, this product ships with all surface-mount components—including the A4988 driver IC—installed as shown in the product picture.



Some unipolar stepper motors (e.g. those with six or eight leads) can be controlled by this driver as bipolar stepper motors. For more information, please see the frequently asked questions. Unipolar motors with five leads cannot be used with this driver.

Included Hardware

The A4988 stepper motor driver carrier with voltage regulators comes with 0.1" male header pins that can be broken into smaller strips and soldered in for use with solderless breadboards or 0.1" female connectors. You can also solder your motor leads and other connections directly to the board.

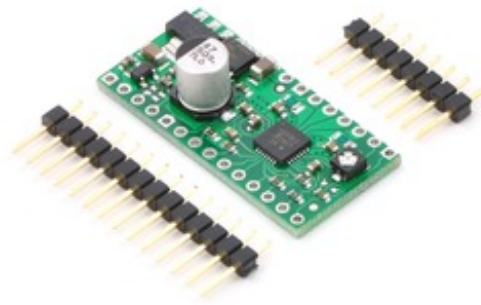

Using the driver

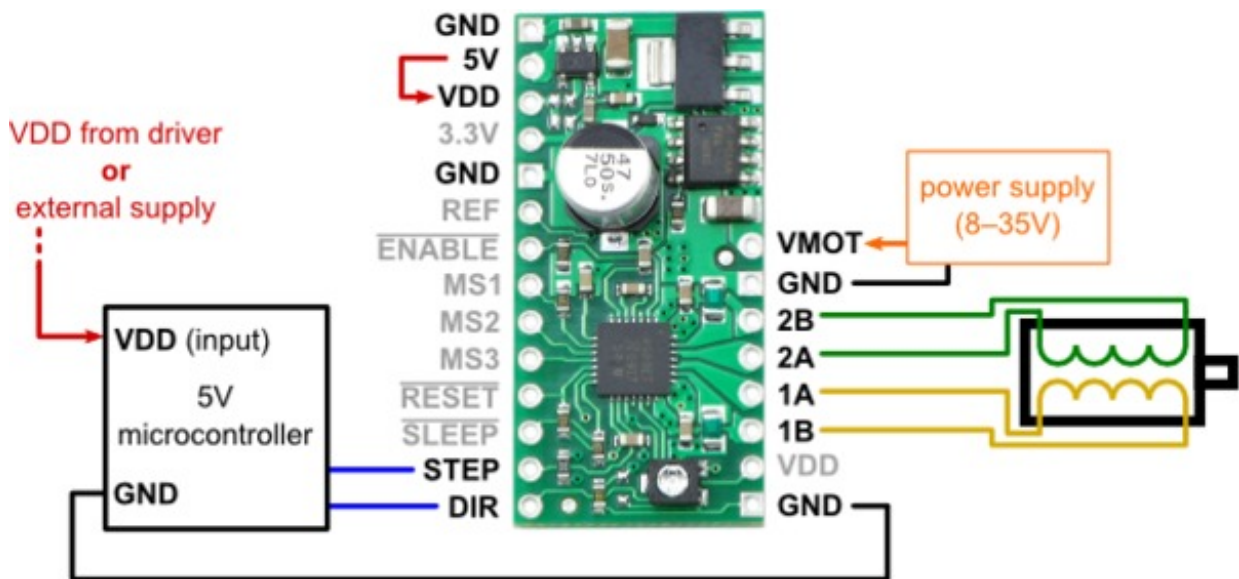

Minimal wiring diagram for wiring a 5V microcontroller to an A4983/A4988 stepper motor driver carrier with voltage regulators (full-step mode).

Power connections

The driver requires a logic supply voltage (3 – 5.5 V) to be connected across the VDD and GND pins and a motor supply voltage (8 – 35 V) to be connected across VMOT and GND. The logic voltage can be supplied from an external source, such as that powering the logic of the rest of the system, or by jumpering the output of the 5 V or 3.3 V voltage regulator outputs to VDD. There are also surface-mount pads that allow VDD selection to be made by making a solder bridge across the appropriate pads. Note that the driver's regulators can also be used to power other electronics in the system, such as the controlling MCU.

The motor power supply should be capable of delivering the expected currents for the stepper motors being used (peaks up to 4 A).

Motor connections

Four, six, and eight-wire stepper motors can be driven by the A4988 if they are properly connected; a FAQ answer explains the proper wirings in detail.

Warning: Connecting or disconnecting a stepper motor while the driver is powered can destroy the driver. (More generally, rewiring anything while it is powered is asking for trouble.)

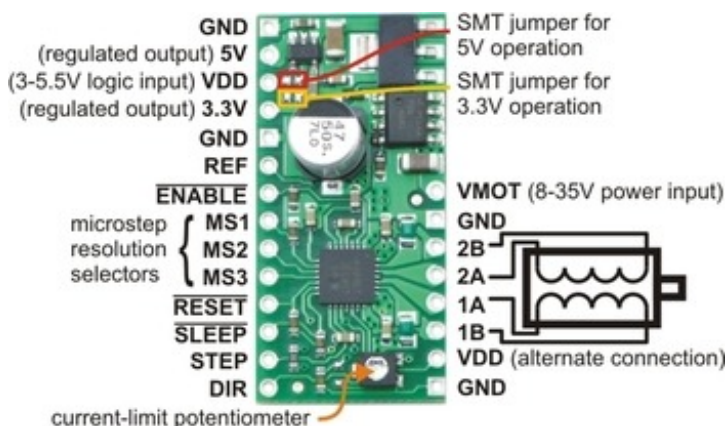

Step (and microstep) size

Stepper motors typically have a step size specification (e.g. 1.8° or 200 steps per revolution), which applies to full steps. A microstepping driver such as the A4988 allows higher resolutions by allowing intermediate step locations, which are achieved by energizing the coils with intermediate current levels. For instance, driving a motor in quarter-step mode will give the 200-step-per-revolution motor 800 microsteps per revolution by using four different current levels.

The resolution (step size) selector inputs (MS1, MS2, and MS3) enable selection from the five step resolutions according to the table below. MS1 and MS3 have internal $100\text{k}\Omega$ pull-down resistors and MS2 has an internal $50\text{k}\Omega$ pull-down resistor, so leaving these three microstep selection pins disconnected results in full-step mode. For the microstep modes to function correctly, the current limit must be set low enough (see below) so that current limiting gets engaged. Otherwise, the intermediate current levels will not be correctly maintained, and the motor will skip microsteps.

MS1	MS2	MS3	Microstep Resolution
Low	Low	Low	Full step
High	Low	Low	Half step
Low	High	Low	Quarter step
High	High	Low	Eighth step
High	High	High	Sixteenth step

Control inputs

Each pulse to the STEP input corresponds to one microstep of the stepper motor in the direction selected by the DIR pin. Note that the STEP and DIR pins are not pulled to any particular voltage internally, so you should not leave either of these pins floating in your application. If you just want rotation in a single direction, you can tie DIR directly to VCC or GND. The chip has three different inputs for controlling its many power states: **RST**, **SLP**, and **EN**. For details about these power states, see the datasheet.

Current limiting

To achieve high step rates, the motor supply is typically much higher than would be permissible without active current limiting. For instance, a typical stepper motor might have a maximum current rating of 1 A with a 5Ω coil resistance, which would indicate a maximum motor supply of 5 V. Using such a motor with 12 V would allow higher step rates, but the current must actively be limited to

under 1 A to prevent damage to the motor.

The A4988 supports such active current limiting, and the trimmer potentiometer on the board can be used to set the current limit. One way to set the current limit is to put the driver into full-step mode and to measure the current running through a single motor coil without clocking the STEP input. The measured current will be 0.7 times the current limit (since both coils are always on and limited to 70% of the current limit setting in full-step mode). Please note that changing the logic voltage, V_{dd}, to a different value will change the current limit setting since the voltage on the REF pin is a function of V_{dd}.

Another way to set the current limit is to measure the voltage on the REF pin and to calculate the resulting current limit (the current sense resistors are 0.05Ω). The current limit relates to the reference voltage as follows:

$$\text{Current Limit} = V_{\text{REF}} \times 2.5$$

So, for example, if the reference voltage is 0.3 V, the current limit is 0.75 A. As mentioned above, in full step mode, the current through the coils is limited to 70% of the current limit, so to get a full-step coil current of 1 A, the current limit should be $1 \text{ A} / 0.7 = 1.4 \text{ A}$, which corresponds to a V_{REF} of $1.4 \text{ A} / 2.5 = 0.56 \text{ V}$. See the A4988 datasheet for more information.



Note: The coil current can be very different from the power supply current, so you should not use the current measured at the power supply to set the current limit. The appropriate place to put your current meter is in series with one of your stepper motor coils.

Power dissipation considerations

The A4988 driver IC has a maximum current rating of 2 A per coil, but the actual current you can deliver depends on how well you can keep the IC cool. The carrier's printed circuit board is designed to draw heat out of the IC, but to supply more than approximately 1 A per coil, a heat sink or other cooling method is required.

This product can get **hot** enough to burn you long before the chip overheats. Take care when handling this product and other components connected to it.

Please note that measuring the current draw at the power supply will generally not provide an accurate measure of the coil current. Since the input voltage to the driver can be significantly higher than the coil voltage, the measured current on the power supply can be quite a bit lower than the coil current (the driver and coil basically act like a switching step-down power supply). Also, if the supply voltage is very high compared to what the motor needs to achieve the set current, the duty cycle will be very low, which also leads to significant differences between average and RMS currents.

Schematic Diagram

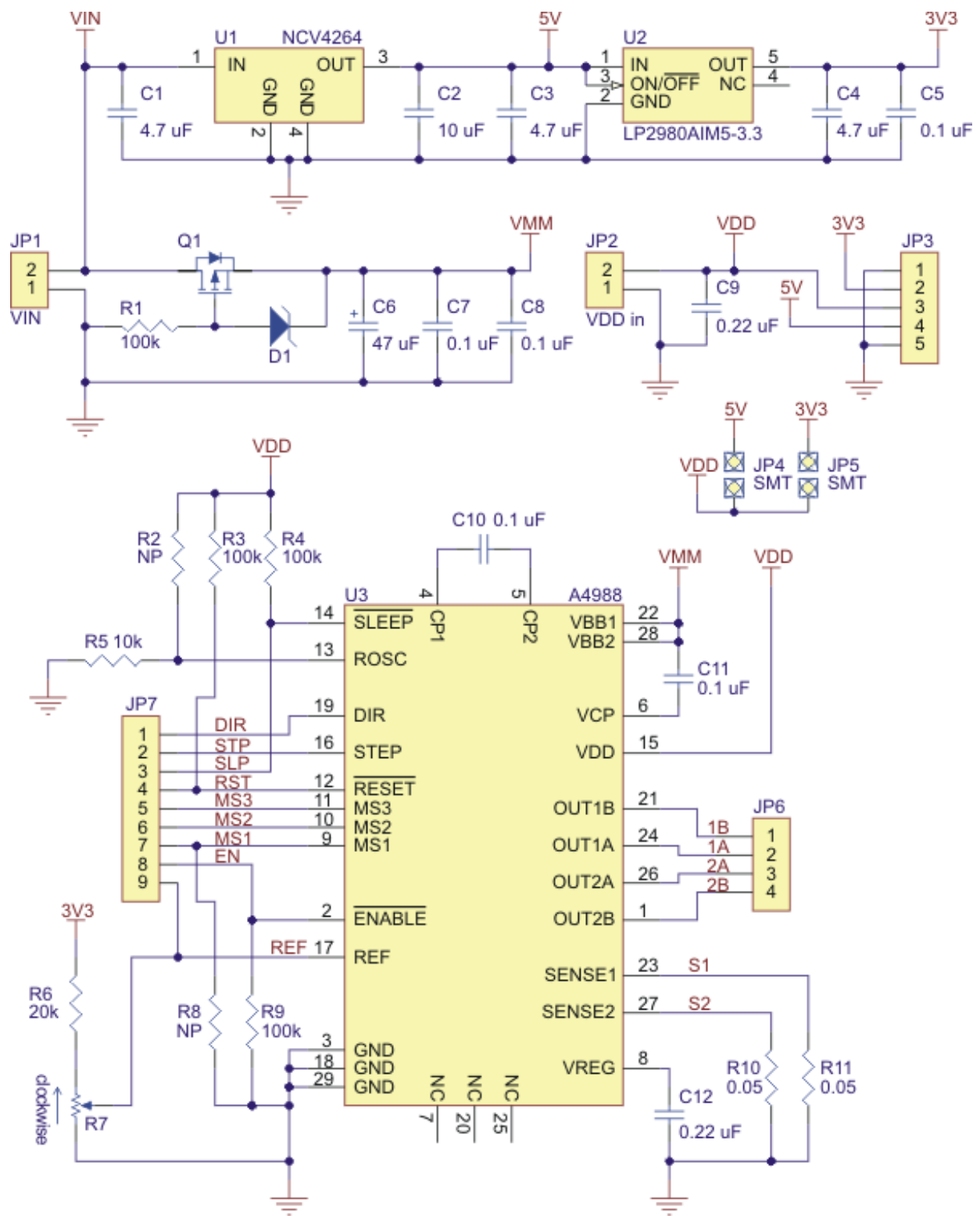

Schematic diagram of the md09a A4988 stepper motor driver carrier with regulators.



Note: This board is a drop-in replacement for the original (and now discontinued) A4983 stepper motor driver carrier with voltage regulators. The key difference is that the newer A4988 offers overcurrent protection that the A4983 lacks; it is otherwise virtually identical to the A4983.

[Documentation on producer website.](#)

X-ON Electronics

Largest Supplier of Electrical and Electronic Components

Click to view similar products for [Motor Control Modules](#) category:

Click to view products by [Pololu](#) manufacturer:

Other Similar products are found below :

[DRI0018](#) [STK551-391A3-E](#) [LV8414CS-N-TE-L-H](#) [BTM7750GXUMA1](#) [TB6608FNG\(C8,EL,HJ](#) [DRI0001](#) [DRI0002](#) [DRI0027](#) [DRI0035](#)
[DRI0039](#) [DRI0040](#) [DRI0044](#) [A4988 STEPPER MOTOR DRIVER CARRIER BLACK](#) [A4988 STEPPER MOTOR DRIVER CARRIER](#)
[DRI0041](#) [STSPIN820 STEPPER MOTOR DRIVER CARRIER](#) [SIMPLE HIGH-POWER MOTOR CONTROLLER 24V12](#) [DUAL G2 HP](#)
[MOTOR DRIVER 24V14 RPI](#) [DUAL G2 HP MOTOR DRIVER 18V18 RPI](#) [TIC T834 USB STEPPER MOTOR CONTROLLER](#) [MP6500](#)
[STEPPER MOTOR DRIVER CARRIER](#) [1411](#) [DFR0508](#) [DFR0513](#) [DRI0044-A](#) [DRI0009](#) [DRI0017](#) [DRI0023](#) [DRV8825 STEPPER](#)
[MOTOR DRIVER CARRIER](#) [LV8731V-MPB-H](#) [NCV70521MN003R2G](#) [AMIS30543C5431RG](#) [DRV8805DWR](#) [UC3625DWTR](#)
[TB6552FNG\(O,8,EL\)](#) [MCP8024T-H/PT](#) [A3983SLPTRT](#) [A3980KLPTRT](#)