

MPC5644A Microcontroller Datasheet

This is the MPC5644A Datasheet set consisting of the following files:

- MPC5644A Datasheet *Addendum (MPC5644A_AD)*, Rev. 1
- MPC5644A Datasheet (*MPC5644A*), Rev. 7

MPC5644A Microcontroller Datasheet Addendum

This addendum describes corrections to the *MPC5644A Microcontroller Datasheet*, order number MPC5644A. For convenience, the addenda items are grouped by revision. Please check our website at <http://www.freescale.com/powerarchitecture> for the latest updates.

The current version available of the *MPC5644A Microcontroller Datasheet* is Revision 7.

Table of Contents

1	Addendum List for Revision 7.....	2
2	Revision History	2

1 Addendum List for Revision 7

Table 1. MPC5644A Rev 7 Addendum

Location	Description
Section 3.11, "Temperature Sensor Electrical Characteristics", Page 90	In "Temperature Sensor Electrical Characteristics" table, update the Min and Max value of "Accuracy" parameter to -20°C and +20°C, respectively.

2 Revision History

Table 2 provides a revision history for this datasheet addendum document.

Table 2. Revision History Table

Rev. Number	Substantive Changes	Date of Release
1.0	Initial release.	12/2014

How to Reach Us:

Home Page:
freescale.com

Web Support:
freescale.com/support

Information in this document is provided solely to enable system and software implementers to use Freescale products. There are no express or implied copyright licenses granted hereunder to design or fabricate any integrated circuits based on the information in this document.

Freescale reserves the right to make changes without further notice to any products herein. Freescale makes no warranty, representation, or guarantee regarding the suitability of its products for any particular purpose, nor does Freescale assume any liability arising out of the application or use of any product or circuit, and specifically disclaims any and all liability, including without limitation consequential or incidental damages. "Typical" parameters that may be provided in Freescale data sheets and/or specifications can and do vary in different applications, and actual performance may vary over time. All operating parameters, including "typicals," must be validated for each customer application by customer's technical experts. Freescale does not convey any license under its patent rights nor the rights of others. Freescale sells products pursuant to standard terms and conditions of sale, which can be found at the following address: freescale.com/SalesTermsandConditions.

Freescale, the Freescale logo, Altivec, C-5, CodeTest, CodeWarrior, ColdFire, C-Ware, Energy Efficient Solutions logo, Kinetis, mobileGT, PowerQUICC, Processor Expert, QorIQ, Qorivva, StarCore, Symphony, and VortiQa are trademarks of Freescale Semiconductor, Inc., Reg. U.S. Pat. & Tm. Off. Airfast, BeeKit, BeeStack, ColdFire+, CoreNet, Flexis, MagniV, MXC, Platform in a Package, QorIQ Qonverge, QUICC Engine, Ready Play, SafeAssure, SMARTMOS, TurboLink, Vybrid, and Xtrinsic are trademarks of Freescale Semiconductor, Inc. All other product or service names are the property of their respective owners.

© 2014 Freescale Semiconductor, Inc.

Document Number: MPC5644A_AD
Rev. 1
12/2014





MPC5644A

MPC5644A Microcontroller Data Sheet

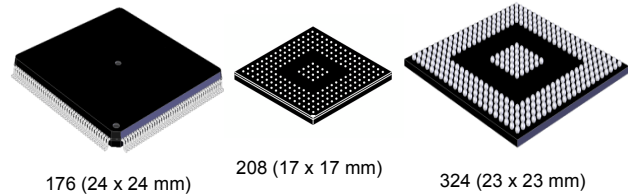

- 150 MHz e200z4 Power Architecture core
 - Variable length instruction encoding (VLE)
 - Superscalar architecture with 2 execution units
 - Up to 2 integer or floating point instructions per cycle
 - Up to 4 multiply and accumulate operations per cycle
 - Memory organization
 - 4 MB on-chip flash memory with ECC and Read While Write (RWW)
 - 192 KB on-chip SRAM with standby functionality (32 KB) and ECC
 - 8 KB instruction cache (with line locking), configurable as 2- or 4-way
 - 14 + 3 KB eTPU code and data RAM
 - 5 × 4 crossbar switch (XBAR)
 - 24-entry MMU
 - External Bus Interface (EBI) with slave and master port
 - Fail Safe Protection
 - 16-entry Memory Protection Unit (MPU)
 - CRC unit with 3 sub-modules
 - Junction temperature sensor
 - Interrupts
 - Configurable interrupt controller (with NMI)
 - 64-channel DMA
 - Serial channels
 - 3 × eSCI
 - 3 × DSPI (2 of which support downstream Micro Second Channel [MSC])
 - 3 × FlexCAN with 64 messages each
 - 1 × FlexRay module (V2.1) up to 10 Mbit/s with dual or single channel and 128 message objects and ECC
 - 1 × eMIOS: 24 unified channels
 - 1 × eTPU2 (second generation eTPU)
 - 32 standard channels
 - 1 × reaction module (6 channels with three outputs per channel)
 - 2 enhanced queued analog-to-digital converters (eQADCs)
 - Forty 12-bit input channels (multiplexed on 2 ADCs); expandable to 56 channels with external multiplexers
 - 6 command queues
 - Trigger and DMA support
 - 688 ns minimum conversion time
 - On-chip CAN/SCI/FlexRay Bootstrap loader with Boot Assist Module (BAM)
 - Nexus
 - Class 3+ for the e200z4 core
 - Class 1 for the eTPU
 - JTAG (5-pin)
 - Development Trigger Semaphore (DTS)
 - Register of semaphores (32-bits) and an identification register
 - Used as part of a triggered data acquisition protocol
 - EVTO pin is used to communicate to the external tool
 - Clock generation
 - On-chip 4–40 MHz main oscillator
 - On-chip FMPLL (frequency-modulated phase-locked loop)
 - Up to 120 general purpose I/O lines
 - Individually programmable as input, output or special function
 - Programmable threshold (hysteresis)
 - Power reduction mode: slow, stop and stand-by modes
 - Flexible supply scheme
 - 5 V single supply with external ballast
 - Multiple external supply: 5 V, 3.3 V and 1.2 V
 - Packages
 - 176 LQFP
 - 208 MAPBGA
 - 324 TEPBGA
- 496-pin CSP (calibration tool only)

This document contains information on a product under development. Freescale reserves the right to change or discontinue this product without notice.

Table of Contents

1	Introduction	3	3.3	Thermal characteristics	67
1.1	Document Overview	3	3.3.1	General notes for specifications at maximum junction temperature	69
1.2	Description	3	3.4	EMI (electromagnetic interference) characteristics	71
1.3	Device comparison	4	3.5	Electrostatic discharge (ESD) characteristics	71
1.4	Feature details	6	3.6	Power management control (PMC) and power on reset (POR) electrical specifications	72
1.4.1	e200z4 core	6	3.6.1	Voltage regulator controller (VRC) electrical specifications	75
1.4.2	Crossbar Switch (XBAR)	6	3.6.2	Regulator Example	76
1.4.3	eDMA	7	3.6.3	Recommended power transistors	77
1.4.4	Interrupt controller	7	3.7	Power up/down sequencing	77
1.4.5	Memory protection unit (MPU)	8	3.8	DC electrical specifications	78
1.4.6	FMPLL	8	3.9	I/O pad current specifications	85
1.4.7	SIU	9	3.9.1	I/O pad V_{RC33} current specifications	86
1.4.8	Flash memory	9	3.9.2	LVDS pad specifications	87
1.4.9	BAM	10	3.10	Oscillator and PLLMRFM electrical characteristics	88
1.4.10	eMIOS	11	3.11	Temperature sensor electrical characteristics	90
1.4.11	eTPU2	11	3.12	eQADC electrical characteristics	90
1.4.12	Reaction module	13	3.13	Configuring SRAM wait states	93
1.4.13	eQADC	13	3.14	Platform flash controller electrical characteristics	93
1.4.14	DSPI	14	3.15	Flash memory electrical characteristics	93
1.4.15	eSCI	15	3.16	AC specifications	95
1.4.16	FlexCAN	15	3.16.1	Pad AC specifications	95
1.4.17	FlexRay	16	3.17	AC timing	98
1.4.18	System timers	17	3.17.1	Reset and configuration pin timing	98
1.4.19	Software watchdog timer (SWT)	17	3.17.2	IEEE 1149.1 interface timing	99
1.4.20	Cyclic redundancy check (CRC) module	18	3.17.3	Nexus timing	102
1.4.21	Error correction status module (ECSM)	18	3.17.4	External Bus Interface (EBI) and calibration bus interface timing	106
1.4.22	External bus interface (EBI)	18	3.17.5	External interrupt timing (IRQ pin)	110
1.4.23	Calibration EBI	19	3.17.6	eTPU timing	110
1.4.24	Power management controller (PMC)	19	3.17.7	eMIOS timing	111
1.4.25	Nexus port controller	19	3.17.8	DSPI timing	111
1.4.26	JTAG	19	3.17.9	eQADC SSI timing	118
1.4.27	Development Trigger Semaphore (DTS)	20	3.17.10	FlexCAN system clock source	119
1.5	MPC5644A series architecture	20	4	Packages	120
1.5.1	Block diagram	20	4.1	Package mechanical data	120
1.5.2	Block summary	22	4.1.1	176 LQFP	120
2	Pinout and signal description	24	4.1.2	208 MAPBGA	123
2.1	176 LQFP pinout	25	4.1.3	324 TEPBGA	125
2.2	208 MAP BGA ballmap	26	5	Ordering information	127
2.3	324 TEPBGA ballmap	27	6	Document revision history	128
2.4	Signal summary	31			
2.5	Signal details	57			
3	Electrical characteristics	65			
3.1	Parameter classification	65			
3.2	Maximum ratings	65			

1 Introduction

1.1 Document Overview

This document provides electrical specifications, pin assignments, and package diagrams for the MPC5644A series of microcontroller units (MCUs). For functional characteristics, refer to the *MPC5644A Microcontroller Reference Manual*.

1.2 Description

The microcontroller's e200z4 host processor core is built on Power Architecture® technology and designed specifically for embedded applications. In addition to the Power Architecture technology, this core supports instructions for digital signal processing (DSP).

The MPC5644A has two levels of memory hierarchy consisting of 8 KB of instruction cache, backed by 192 KB on-chip SRAM and 4 MB of internal flash memory. The MPC5644A includes an external bus interface, and also a calibration bus that is only accessible when using the Freescale VertiCal Calibration System.

This document describes the features of the MPC5644A and highlights important electrical and physical characteristics of the device.

1.3 Device comparison

Table 1 summarizes the MPC5644A and compares it to the MPC5634M.

Table 1. MPC5644A, MPC5634M and MPC5642A comparison

Feature	MPC5644A	MPC5634M	MPC5642A
Process	90 nm		
Core	e200z4	e200z3	e200z4
SIMD	Yes		
VLE	Yes		
Cache	8 KB instruction	No	8 KB instruction
Non-Maskable Interrupt (NMI)	NMI & Critical Interrupt		
MMU	24 entry	16 entry	24 entry
MPU	16 entry	No	16 entry
Crossbar switch	5 × 4	3 × 4	4 × 4
Core performance	0–150 MHz	0–80 MHz	0–150 MHz
Windowing software watchdog	Yes		
Core Nexus	Class 3+	Class 2+	Class 3+
SRAM	192 KB	94 KB	128 KB
Flash	4 MB	1.5 MB	2 MB
Flash fetch accelerator	4 × 256-bit	4 × 128-bit	
External bus	16-bit (incl 32-bit muxed)	None	
Calibration bus	16-bit (incl 32-bit muxed)	16-bit	16-bit (incl 32-bit muxed)
DMA	64 ch.	32 ch.	64 ch.
DMA Nexus	None		
Serial	3	2	3
eSCI_A	Yes (MSC Uplink)		
eSCI_B	Yes (MSC Uplink)		
eSCI_C	Yes	No	Yes
CAN	3	2	3
CAN_A	64 buf		
CAN_B	64 buf	No	64 buf
CAN_C	64 buf	32 buf	64 buf
SPI	3	2	3

Table 1. MPC5644A, MPC5634M and MPC5642A comparison (continued)

Feature		MPC5644A	MPC5634M	MPC5642A
	Micro Second Channel (MSC) bus downlink	Yes		
	DSPI_A	No		
	DSPI_B	Yes (with LVDS)		
	DSPI_C	Yes (with LVDS)		
	DSPI_D	Yes	No	Yes
FlexRay		Yes	No	Yes
System timers		5 PIT channels 4 STM channels 1 Software Watchdog		
eMIOS		24 ch.	16 ch.	24 ch.
eTPU		32 ch. eTPU2		
	Code memory	14 KB		
	Data memory	3 KB		
Interrupt controller		486 ch. ¹	307 ch.	486 ch. ¹
ADC		40 ch.	34 ch.	40 ch.
	ADC_A	Yes		
	ADC_B	Yes		
	Temp sensor	Yes		
	Variable gain amp.	Yes		
	Decimation filter	2	1	2
	Sensor diagnostics	Yes		
CRC		Yes	No	Yes
FMPLL		Yes		
VRC		Yes		
Supplies		5 V, 3.3 V ²	5 V, 3.3 V ³	5 V, 3.3 V ²
Low-power modes		Stop Mode Slow Mode		
Packages		176 LQFP ⁴ 208 MAPBGA ^{4,5} 324 TEPBGA324 ⁶ 496-pin CSP ⁷	144 LQFP 176 LQFP 208 MAPBGA 496-pin CSP ⁷	176 LQFP ⁴ 208 MAPBGA ^{4,5} 324 TEPBGA324 ⁶ 496-pin CSP ⁷

¹ 199 interrupt vectors are reserved.

² 5 V single supply only for 176 LQFP.

³ 5 V single supply only for 144 LQFP.

⁴ Pinout compatible with Freescale's MPC5634M devices.

⁵ Pinout compatible with Freescale's MPC5534.

⁶ Ballmap upwardly compatible with the standardized package ballmap used for various Freescale MPC5xxx family members, including MPC5554, MPC5567 and MPC5666.

⁷ For Freescale VertiCal Calibration System only.

1.4 Feature details

1.4.1 e200z4 core

MPC5644A devices have a high performance e200z448n3 core processor:

- Dual issue, 32-bit Power Architecture embedded category CPU
- Variable Length Encoding Enhancements
- 8 KB instruction cache: 2- or 4- way set associative instruction cache
- Thirty-two 64-bit general purpose registers (GPRs)
- Memory management unit (MMU) with 24-entry fully-associative translation look-aside buffer (TLB)
- Harvard Architecture: Separate instruction bus and load/store bus
- Vectored interrupt support
- Non-maskable interrupt input
- Critical Interrupt input
- New ‘Wait for Interrupt’ instruction, to be used with new low power modes
- Reservation instructions for implementing read-modify-write accesses
- Signal processing extension (SPE) APU
- Single Precision Floating point (scalar and vector)
- Nexus Class 3+ debug
- Process ID manipulation for the MMU using an external tool

1.4.2 Crossbar Switch (XBAR)

The XBAR multiport crossbar switch supports simultaneous connections between five master ports and four slave ports. The crossbar supports a 32-bit address bus width and a 64-bit data bus width.

The crossbar allows three concurrent transactions to occur from the master ports to any slave port but each master must access a different slave. If a slave port is simultaneously requested by more than one master port, arbitration logic selects the higher priority master and grants it ownership of the slave port. All other masters requesting that slave port are stalled until the higher priority master completes its transactions. Requesting masters are treated with equal priority and are granted access to a slave port in round-robin fashion, based upon the ID of the last master to be granted access. The crossbar provides the following features:

- 5 master ports
 - CPU instruction bus
 - CPU data bus
 - eDMA
 - FlexRay
 - External Bus Interface
- 4 slave ports
 - Flash
 - Calibration and EBI bus
 - SRAM
 - Peripheral bridge
- 32-bit internal address, 64-bit internal data paths

1.4.3 eDMA

The enhanced direct memory access (eDMA) controller is a second-generation module capable of performing complex data movements via 64 programmable channels, with minimal intervention from the host processor. The hardware micro-architecture includes a DMA engine which performs source and destination address calculations, and the actual data movement operations, along with an SRAM-based memory containing the transfer control descriptors (TCD) for the channels. This implementation is utilized to minimize the overall block size. The eDMA module provides the following features:

- All data movement via dual-address transfers: read from source, write to destination
- Programmable source and destination addresses, transfer size, plus support for enhanced addressing modes
- Transfer control descriptor organized to support two-deep, nested transfer operations
- An inner data transfer loop defined by a “minor” byte transfer count
- An outer data transfer loop defined by a “major” iteration count
- Channel activation via one of three methods:
 - Explicit software initiation
 - Initiation via a channel-to-channel linking mechanism for continuous transfers
 - Peripheral-paced hardware requests (one per channel)
- Support for fixed-priority and round-robin channel arbitration
- Channel completion reported via optional interrupt requests
- One interrupt per channel, optionally asserted at completion of major iteration count
- Error termination interrupts optionally enabled
- Support for scatter/gather DMA processing
- Ability to suspend channel transfers by a higher priority channel

1.4.4 Interrupt controller

The INTC (interrupt controller) provides priority-based preemptive scheduling of interrupt requests, suitable for statically scheduled hard real-time systems.

For high priority interrupt requests, the time from the assertion of the interrupt request from the peripheral to when the processor is executing the interrupt service routine (ISR) has been minimized. The INTC provides a unique vector for each interrupt request source for quick determination of which ISR needs to be executed. It also provides an ample number of priorities so that lower priority ISRs do not delay the execution of higher priority ISRs. To allow the appropriate priorities for each source of interrupt request, the priority of each interrupt request is software configurable.

When multiple tasks share a resource, coherent accesses to that resource need to be supported. The INTC supports the priority ceiling protocol for coherent accesses. By providing a modifiable priority mask, the priority can be raised temporarily so that all tasks which share the resource cannot preempt each other.

The INTC provides the following features:

- 9-bit vector addresses
- Unique vector for each interrupt request source
- Hardware connection to processor or read from register
- Each interrupt source can assigned a specific priority by software
- Preemptive prioritized interrupt requests to processor
- ISR at a higher priority preempts executing ISRs or tasks at lower priorities
- Automatic pushing or popping of preempted priority to or from a LIFO
- Ability to modify the ISR or task priority to implement the priority ceiling protocol for accessing shared resources
- Low latency—three clocks from receipt of interrupt request from peripheral to interrupt request to processor

This device also includes a non-maskable interrupt (NMI) pin that bypasses the INTC and multiplexing logic.

1.4.5 Memory protection unit (MPU)

The Memory Protection Unit (MPU) provides hardware access control for all memory references generated in a device. Using preprogrammed region descriptors, which define memory spaces and their associated access rights, the MPU concurrently monitors all system bus transactions and evaluates the appropriateness of each transfer. Memory references with sufficient access control rights are allowed to complete; references that are not mapped to any region descriptor or have insufficient rights are terminated with a protection error response.

The MPU has these major features:

- Support for 16 memory region descriptors, each 128 bits in size
 - Specification of start and end addresses provide granularity for region sizes from 32 bytes to 4 GB
 - MPU is invalid at reset, thus no access restrictions are enforced
 - Two types of access control definitions: processor core bus master supports the traditional {read, write, execute} permissions with independent definitions for supervisor and user mode accesses; the remaining non-core bus masters (eDMA, FlexRay, and EBI¹) support {read, write} attributes
 - Automatic hardware maintenance of the region descriptor valid bit removes issues associated with maintaining a coherent image of the descriptor
 - Alternate memory view of the access control word for each descriptor provides an efficient mechanism to dynamically alter the access rights of a descriptor only¹
 - For overlapping region descriptors, priority is given to permission granting over access denying as this approach provides more flexibility to system software
- Support for two XBAR slave port connections (SRAM and PBRIDGE)
 - For each connected XBAR slave port (SRAM and PBRIDGE), MPU hardware monitors every port access using the pre-programmed memory region descriptors
 - An access protection error is detected if a memory reference does not hit in any memory region or the reference is flagged as illegal in all memory regions where it does hit. In the event of an access error, the XBAR reference is terminated with an error response and the MPU inhibits the bus cycle being sent to the targeted slave device
 - 64-bit error registers, one for each XBAR slave port, capture the last faulting address, attributes, and detail information

1.4.6 FMPLL

The FMPLL allows the user to generate high speed system clocks from a 4 MHz to 40 MHz crystal oscillator or external clock generator. Further, the FMPLL supports programmable frequency modulation of the system clock. The PLL multiplication factor, output clock divider ratio are all software configurable. The PLL has the following major features:

- Input clock frequency from 4 MHz to 40 MHz
- Reduced frequency divider (RFD) for reduced frequency operation without forcing the PLL to relock
- Three modes of operation
 - Bypass mode with PLL off
 - Bypass mode with PLL running (default mode out of reset)
 - PLL normal mode
- Each of the three modes may be run with a crystal oscillator or an external clock reference
- Programmable frequency modulation
 - Modulation enabled/disabled through software
 - Triangle wave modulation up to 100 kHz modulation frequency
 - Programmable modulation depth (0% to 2% modulation depth)
 - Programmable modulation frequency dependent on reference frequency

1. EBI not available on all packages and is not available, as a master, for customer.

- Lock detect circuitry reports when the PLL has achieved frequency lock and continuously monitors lock status to report loss of lock conditions
- Clock Quality Module
 - Detects the quality of the crystal clock and causes interrupt request or system reset if error is detected
 - Detects the quality of the PLL output clock; if error detected, causes system reset or switches system clock to crystal clock and causes interrupt request
- Programmable interrupt request or system reset on loss of lock
- Self-clocked mode (SCM) operation

1.4.7 SIU

The MPC5644A SIU controls MCU reset configuration, pad configuration, external interrupt, general purpose I/O (GPIO), internal peripheral multiplexing, and the system reset operation. The reset configuration block contains the external pin boot configuration logic. The pad configuration block controls the static electrical characteristics of I/O pins. The GPIO block provides uniform and discrete input/output control of the I/O pins of the MCU. The reset controller performs reset monitoring of internal and external reset sources, and drives the $\overline{\text{RSTOUT}}$ pin. Communication between the SIU and the e200z4 CPU core is via the crossbar switch. The SIU provides the following features:

- System configuration
 - MCU reset configuration via external pins
 - Pad configuration control for each pad
 - Pad configuration control for virtual I/O via DSPI serialization
- System reset monitoring and generation
 - Power-on reset support
 - Reset status register provides last reset source to software
 - Glitch detection on reset input
 - Software controlled reset assertion
- External interrupt
 - Rising or falling edge event detection
 - Programmable digital filter for glitch rejection
 - Critical Interrupt request
 - Non-Maskable Interrupt request
- GPIO
 - Centralized control of I/O and bus pins
 - Virtual GPIO via DSPI serialization (requires external deserialization device)
 - Dedicated input and output registers for setting each GPIO and Virtual GPIO pin
- Internal multiplexing
 - Allows serial and parallel chaining of DSPIs
 - Allows flexible selection of eQADC trigger inputs
 - Allows selection of interrupt requests between external pins and DSPI

1.4.8 Flash memory

The MPC5644A provides up to 4 MB of programmable, non-volatile, flash memory. The non-volatile memory (NVM) can be used to store instructions or data, or both. The flash module includes a Fetch Accelerator that optimizes the performance of the flash array to match the CPU architecture. The flash module interfaces the system bus to a dedicated flash memory array controller. For CPU 'loads', DMA transfers and CPU instruction fetch, it supports a 64-bit data bus width at the system bus port,

and 128- and 256-bit read data interfaces to flash memory. The module contains a prefetch controller which prefetches sequential lines of data from the flash array into the buffers. Prefetch buffer hits allow no-wait responses.

The flash memory provides the following features:

- Supports a 64-bit data bus for instruction fetch, CPU loads and DMA access. Byte, halfword, word and doubleword reads are supported. Only aligned word and doubleword writes are supported.
- Fetch Accelerator
 - Architected to optimize the performance of the flash
 - Configurable read buffering and line prefetch support
 - Four-entry 256-bit wide line read buffer
 - Prefetch controller
- Hardware and software configurable read and write access protections on a per-master basis
- Interface to the flash array controller pipelined with a depth of one, allowing overlapped accesses to proceed in parallel for interleaved or pipelined flash array designs
- Configurable access timing usable in a wide range of system frequencies
- Multiple-mapping support and mapping-based block access timing (0-31 additional cycles) usable for emulation of other memory types
- Software programmable block program/erase restriction control
- Erase of selected block(s)
- Read page size of 128 bits (four words)
- ECC with single-bit correction, double-bit detection
- Program page size of 128 bits (four words) to accelerate programming
- ECC single-bit error corrections are visible to software
- Minimum program size is two consecutive 32-bit words, aligned on a 0-modulo-8 byte address, due to ECC
- Embedded hardware program and erase algorithm
- Erase suspend, program suspend and erase-suspended program
- Shadow information stored in non-volatile shadow block
- Independent program/erase of the shadow block

1.4.9 BAM

The BAM (Boot Assist Module) is a block of read-only memory that is programmed once by Freescale and is identical for all MPC5644A MCUs. The BAM program is executed every time the MCU is powered-on or reset in normal mode. The BAM supports different modes of booting. They are:

- Booting from internal flash memory
- Serial boot loading (A program is downloaded into RAM via eSCI or the FlexCAN and then executed)
- Booting from external memory on external bus

The BAM also reads the reset configuration half word (RCHW) from internal flash memory and configures the MPC5644A hardware accordingly. The BAM provides the following features:

- Sets up MMU to cover all resources and mapping of all physical addresses to logical addresses with minimum address translation
- Sets up MMU to allow user boot code to execute as either Power Architecture embedded category (default) or as Freescale VLE code
- Location and detection of user boot code
- Automatic switch to serial boot mode if internal flash is blank or invalid
- Supports user programmable 64-bit password protection for serial boot mode
- Supports serial bootloading via FlexCAN bus and eSCI using Freescale protocol

- Supports serial bootloading via FlexCAN bus and eSCI with auto baud rate sensing
- Supports serial bootloading of either Power Architecture code (default) or Freescale VLE code
- Supports booting from calibration bus interface
- Supports censorship protection for internal flash memory
- Provides an option to enable the core watchdog timer
- Provides an option to disable the system watchdog timer

1.4.10 eMIOS

The eMIOS timer module provides the capability to generate or measure events in hardware.

The eMIOS module features include:

- Twenty-four 24-bit wide channels
- 3 channels' internal timebases can be shared between channels
- 1 Timebase from eTPU2 can be imported and used by the channels
- Global enable feature for all eMIOS and eTPU timebases
- Dedicated pin for each channel (not available on all package types)

Each channel (0–23) supports the following functions:

- General-purpose input/output (GPIO)
- Single-action input capture (SAIC)
- Single-action output compare (SAOC)
- Output pulse-width modulation buffered (OPWMB)
- Input period measurement (IPM)
- Input pulse-width measurement (IPWM)
- Double-action output compare (DAOC)
- Modulus counter buffered (MCB)
- Output pulse width and frequency modulation buffered (OPWFMB)

1.4.11 eTPU2

The eTPU2 is an enhanced co-processor designed for timing control. Operating in parallel with the host CPU, the eTPU2 processes instructions and real-time input events, performs output waveform generation, and accesses shared data without host intervention. Consequently, for each timer event, the host CPU setup and service times are minimized or eliminated. A powerful timer subsystem is formed by combining the eTPU2 with its own instruction and data RAM. High-level assembler/compiler and documentation allows customers to develop their own functions on the eTPU2.

MPC5644A devices feature the second generation of the eTPU, called eTPU2. Enhancements of the eTPU2 over the standard eTPU include:

- The Timer Counter (TCR1), channel logic and digital filters (both channel and the external timer clock input [TCRCLK]) now have an option to run at full system clock speed or system clock / 2.
- Channels support unordered transitions: transition 2 can now be detected before transition 1. Related to this enhancement, the transition detection latches (TDL1 and TDL2) can now be independently negated by microcode.
- A new User Programmable Channel Mode has been added: the blocking, enabling, service request and capture characteristics of this channel mode can be programmed via microcode.
- Microinstructions now provide an option to issue Interrupt and Data Transfer requests selected by channel. They can also be requested simultaneously at the same instruction.
- Channel Flags 0 and 1 can now be tested for branching, in addition to selecting the entry point.
- Channel digital filters can be bypassed.

The eTPU2 includes these distinctive features:

- 32 channels; each channel associated with one input and one output signal
 - Enhanced input digital filters on the input pins for improved noise immunity
 - Identical, orthogonal channels: each channel can perform any time function. Each time function can be assigned to more than one channel at a given time, so each signal can have any functionality.
 - Each channel has an event mechanism which supports single and double action functionality in various combinations. It includes two 24-bit capture registers, two 24-bit match registers, 24-bit greater-equal and equal-only comparators.
 - Input and output signal states visible from the host
- 2 independent 24-bit time bases for channel synchronization:
 - First time base clocked by system clock with programmable prescale division from 2 to 512 (in steps of 2), or by output of second time base prescaler
 - Second time base counter can work as a continuous angle counter, enabling angle based applications to match angle instead of time
 - Both time bases can be exported to the eMIOS timer module
 - Both time bases visible from the host
- Event-triggered microengine:
 - Fixed-length instruction execution in two-system-clock microcycle
 - 14 KB of code memory (SCM)
 - 3 KB of parameter (data) RAM (SPRAM)
 - Parallel execution of data memory, ALU, channel control and flow control sub-instructions in selected combinations
 - 32-bit microengine registers and 24-bit wide ALU, with 1 microcycle addition and subtraction, absolute value, bitwise logical operations on 24-bit, 16-bit, or byte operands, single-bit manipulation, shift operations, sign extension and conditional execution
 - Additional 24-bit Multiply/MAC/Divide unit which supports all signed/unsigned Multiply/MAC combinations, and unsigned 24-bit divide. The MAC/Divide unit works in parallel with the regular microcode commands.
- Resource sharing features support channel use of common channel registers, memory and microengine time:
 - Hardware scheduler works as a “task management” unit, dispatching event service routines by predefined, host-configured priority
 - Automatic channel context switch when a “task switch” occurs, that is, one function thread ends and another begins to service a request from other channel: channel-specific registers, flags and parameter base address are automatically loaded for the next serviced channel
 - SPRAM shared between host CPU and eTPU2, supporting communication either between channels and host or inter-channel
 - Hardware implementation of four semaphores support coherent parameter sharing between both eTPU engines
 - Dual-parameter coherency hardware support allows atomic access to two parameters by host
- Test and development support features:
 - Nexus Class 1 debug, supporting single-step execution, arbitrary microinstruction execution, hardware breakpoints and watchpoints on several conditions
 - Software breakpoints
 - SCM continuous signature-check built-in self test (MISC - multiple input signature calculator), runs concurrently with eTPU2 normal operation

1.4.12 Reaction module

The reaction module provides the ability to modulate output signals to manage closed loop control without CPU assistance. It works in conjunction with the eQADC and eTPU2 to increase system performance by removing the CPU from the current control loop.

The reaction module has the following features:

- Six reaction channels
- Each channel output is a bus of three signals, providing ability to control 3 inputs.
- Each channel can implement a peak and hold waveform, making it possible to implement up to six independent peak and hold control channels

Target applications include solenoid control for direct injection systems and valve control in automatic transmissions

1.4.13 eQADC

The enhanced queued analog to digital converter (eQADC) block provides accurate and fast conversions for a wide range of applications. The eQADC provides a parallel interface to two on-chip analog to digital converters (ADC), and a single master to single slave serial interface to an off-chip external device. Both on-chip ADCs have access to all the analog channels.

The eQADC prioritizes and transfers commands from six command conversion command ‘queues’ to the on-chip ADCs or to the external device. The block can also receive data from the on-chip ADCs or from an off-chip external device into the six result queues, in parallel, independently of the command queues. The six command queues are prioritized with Queue_0 having the highest priority and Queue_5 the lowest. Queue_0 also has the added ability to bypass all buffering and queuing and abort a currently running conversion on either ADC and start a Queue_0 conversion. This means that Queue_0 will always have a deterministic time from trigger to start of conversion, irrespective of what tasks the ADCs were performing when the trigger occurred. The eQADC supports software and external hardware triggers from other blocks to initiate transfers of commands from the queues to the on-chip ADCs or to the external device. It also monitors the fullness of command queues and result queues, and accordingly generates DMA or interrupt requests to control data movement between the queues and the system memory, which is external to the eQADC.

The ADCs also support features designed to allow the direct connection of high impedance acoustic sensors that might be used in a system for detecting engine knock. These features include differential inputs; integrated variable gain amplifiers for increasing the dynamic range; programmable pull-up and pull-down resistors for biasing and sensor diagnostics.

The eQADC also integrates a programmable decimation filter capable of taking in ADC conversion results at a high rate, passing them through a hardware low pass filter, then down-sampling the output of the filter and feeding the lower sample rate results to the result FIFOs. This allows the ADCs to sample the sensor at a rate high enough to avoid aliasing of out-of-band noise; while providing a reduced sample rate output to minimize the amount DSP processing bandwidth required to fully process the digitized waveform.

The eQADC provides the following features:

- Dual on-chip ADCs
 - 2×12 -bit ADC resolution
 - Programmable resolution for increased conversion speed (12-bit, 10-bit, 8-bit)
 - 12-bit conversion time: 938 ns (1 M sample/sec)
 - 10-bit conversion time: 813 ns (1.2 M sample/second)
 - 8-bit conversion time: 688 ns (1.4 M sample/second)
 - Up to 10-bit accuracy at 500 KSample/s and 8-bit accuracy at 1 MSample/s
 - Differential conversions
 - Single-ended signal range from 0 to 5 V
 - Variable gain amplifiers on differential inputs ($\times 1$, $\times 2$, $\times 4$)
 - Sample times of 2 (default), 8, 64 or 128 ADC clock cycles

- Provides time stamp information when requested
- Allows time stamp information relative to eTPU clock sources, such as an angle clock
- Parallel interface to eQADC CFIFOs and RFIFOs
- Supports both right-justified unsigned and signed formats for conversion results
- 40 single-ended input channels, expandable to 56 channels with external multiplexers (supports four external 8-to-1 muxes)
- 8 channels can be used as 4 pairs of differential analog input channels
- Differential channels include variable gain amplifier for improved dynamic range
- Differential channels include programmable pull-up and pull-down resistors for biasing and sensor diagnostics (200 k Ω , 100 k Ω , 5 k Ω)
- Additional internal channels for monitoring voltages (such as core voltage, I/O voltage, LVI voltages, etc.) inside the device
- An internal bandgap reference to allow absolute voltage measurements
- Silicon die temperature sensor
 - Provides temperature of silicon as an analog value
 - Read using an internal ADC analog channel
 - May be read with either ADC
- 2 Decimation Filters
 - Programmable decimation factor (1 to 16)
 - Selectable IIR or FIR filter
 - Up to 4th order IIR or 8th order FIR
 - Programmable coefficients
 - Saturated or non-saturated modes
 - Programmable Rounding (Convergent; Two's Complement; Truncated)
 - Prefill mode to precondition the filter before the sample window opens
 - Supports Multiple Cascading Decimation Filters to implement more complex filter designs
 - Optional Absolute Integrators on the output of Decimation Filters
- Full duplex synchronous serial interface to an external device
 - Free-running clock for use by an external device
 - Supports a 26-bit message length
- Priority based queues
 - Supports six queues with fixed priority. When commands of distinct queues are bound for the same ADC, the higher priority queue is always served first
 - Queue_0 can bypass all prioritization, buffering and abort current conversions to start a Queue_0 conversion a deterministic time after the queue trigger
 - Supports software and hardware trigger modes to arm a particular queue
 - Generates interrupt when command coherency is not achieved
- External hardware triggers
 - Supports rising edge, falling edge, high level and low level triggers
 - Supports configurable digital filter

1.4.14 DSPI

The deserial serial peripheral interface (DSPI) block provides a synchronous serial interface for communication between the MPC5644A MCU and external devices. The DSPI supports pin count reduction through serialization and deserialization of eTPU and eMIOS channels and memory-mapped registers. The channels and register content are transmitted using a SPI-like protocol. This SPI-like protocol is completely configurable for baud rate, polarity and phase, frame length, chip select assertion,

etc. Each bit in the frame may be configured to serialize either eTPU channels, eMIOS channels or GPIO signals. The DSPI can be configured to serialize data to an external device that implements the Microsecond Bus protocol. There are three identical DSPI blocks on the MPC5644A MCU. The DSPI pins support 5 V logic levels or Low Voltage Differential Signalling (LVDS) to improve high speed operation.

DSPI module features include:

- Selectable LVDS pads working at 40 MHz for SOUT and SCK pins for DSPI_B and DSPI_C
- 3 sources of serialized data: eTPU_A, eMIOS output channels and memory-mapped register in the DSPI
- 4 destinations for deserialized data: eTPU_A and eMIOS input channels, SIU external Interrupt input request, memory-mapped register in the DSPI
- 32-bit DSI and TSB modes require 32 PCR registers, 32 GPO and GPI registers in the SIU to select either GPIO, eTPU or eMIOS bits for serialization
- The DSPI Module can generate and check parity in a serial frame

1.4.15 eSCI

Three enhanced serial communications interface (eSCI) modules provide asynchronous serial communications with peripheral devices and other MCUs, and include support to interface to Local Interconnect Network (LIN) slave devices. Each eSCI block provides the following features:

- Full-duplex operation
- Standard mark/space non-return-to-zero (NRZ) format
- 13-bit baud rate selection
- Programmable 8-bit or 9-bit, data format
- Programmable 12-bit or 13-bit data format for Timed Serial Bus (TSB) configuration to support the Microsecond bus standard
- Automatic parity generation
- LIN support
 - Autonomous transmission of entire frames
 - Configurable to support all revisions of the LIN standard
 - Automatic parity bit generation
 - Double stop bit after bit error
 - 10- or 13-bit break support
- Separately enabled transmitter and receiver
- Programmable transmitter output parity
- 2 receiver wake-up methods:
 - Idle line wake-up
 - Address mark wake-up
- Interrupt-driven operation with flags
- Receiver framing error detection
- Hardware parity checking
- 1/16 bit-time noise detection
- DMA support for both transmit and receive data
 - Global error bit stored with receive data in system RAM to allow post processing of errors

1.4.16 FlexCAN

The MPC5644A MCU includes three controller area network (FlexCAN) blocks. The FlexCAN module is a communication controller implementing the CAN protocol according to Bosch Specification version 2.0B. The CAN protocol was designed to

be used primarily as a vehicle serial data bus, meeting the specific requirements of this field: real-time processing, reliable operation in the EMI environment of a vehicle, cost-effectiveness and required bandwidth. Each FlexCAN module contains 64 message buffers.

The FlexCAN modules provide the following features:

- Based on and including all existing features of the Freescale TouCAN module
- Full Implementation of the CAN protocol specification, Version 2.0B
 - Standard data and remote frames
 - Extended data and remote frames
 - Zero to eight bytes data length
 - Programmable bit rate up to 1 Mbit/s
- Content-related addressing
- 64 message buffers of zero to eight bytes data length
- Individual Rx Mask Register per message buffer
- Each message buffer configurable as Rx or Tx, all supporting standard and extended messages
- Includes 1088 bytes of embedded memory for message buffer storage
- Includes 256-byte memory for storing individual Rx mask registers
- Full featured Rx FIFO with storage capacity for six frames and internal pointer handling
- Powerful Rx FIFO ID filtering, capable of matching incoming IDs against 8 extended, 16 standard or 32 partial (8 bits) IDs, with individual masking capability
- Selectable backwards compatibility with previous FlexCAN versions
- Programmable clock source to the CAN Protocol Interface, either system clock or oscillator clock
- Listen only mode capability
- Programmable loop-back mode supporting self-test operation
- 3 programmable Mask Registers
- Programmable transmit-first scheme: lowest ID, lowest buffer number or highest priority
- Time Stamp based on 16-bit free-running timer
- Global network time, synchronized by a specific message
- Maskable interrupts
- Warning interrupts when the Rx and Tx Error Counters reach 96
- Independent of the transmission medium (an external transceiver is assumed)
- Multi-master concept
- High immunity to EMI
- Short latency time due to an arbitration scheme for high-priority messages
- Low power mode, with programmable wake-up on bus activity

1.4.17 FlexRay

The MPC5644A includes one dual-channel FlexRay module that implements the FlexRay Communications System Protocol Specification, Version 2.1 Rev A. Features include:

- Single channel support
- FlexRay bus data rates of 10 Mbit/s, 8 Mbit/s, 5 Mbit/s, and 2.5 Mbit/s supported
- 128 message buffers, each configurable as:
 - Receive message buffer
 - Single buffered transmit message buffer
 - Double buffered transmit message buffer (combines two single buffered message buffer)
- 2 independent receive FIFOs

- 1 receive FIFO per channel
- Up to 255 entries for each FIFO
- ECC support

1.4.18 System timers

The system timers include two distinct types of system timer:

- Periodic interrupts/triggers using the Periodic Interrupt Timer (PIT)
- Operating system task monitors using the System Timer Module (STM)

1.4.18.1 Periodic interrupt timer (PIT)

The PIT provides five independent timer channels, capable of producing periodic interrupts and periodic triggers. The PIT has no external input or output pins and is intended to provide system ‘tick’ signals to the operating system, as well as periodic triggers for eQADC queues. Of the five channels in the PIT, four are clocked by the system clock and one is clocked by the crystal clock. This one channel is also referred to as Real-Time Interrupt (RTI) and is used to wake up the device from low power stop mode.

The following features are implemented in the PIT:

- 5 independent timer channels
- Each channel includes 32-bit wide down counter with automatic reload
- 4 channels clocked from system clock
- 1 channel clocked from crystal clock (wake-up timer)
- Wake-up timer remains active when System STOP mode is entered; used to restart system clock after predefined time-out period
- Each channel optionally able to generate an interrupt request or a trigger event (to trigger eQADC queues) when timer reaches zero

1.4.18.2 System timer module (STM)

The System Timer Module (STM) is designed to implement the software task monitor as defined by AUTOSAR¹. It consists of a single 32-bit counter, clocked by the system clock, and four independent timer comparators. These comparators produce a CPU interrupt when the timer exceeds the programmed value.

The following features are implemented in the STM:

- One 32-bit up counter with 8-bit prescaler
- Four 32-bit compare channels
- Independent interrupt source for each channel
- Counter can be stopped in debug mode

1.4.19 Software watchdog timer (SWT)

The Software Watchdog Timer (SWT) is a second watchdog module to complement the standard Power Architecture watchdog integrated in the CPU core. The SWT is a 32-bit modulus counter, clocked by the system clock or the crystal clock, that can provide a system reset or interrupt request when the correct software key is not written within the required time window.

The following features are implemented:

- 32-bit modulus counter
- Clocked by system clock or crystal clock

1.AUTOSAR: AUTomotive Open System ARchitecture (see <http://www.autosar.org>)

- Optional programmable watchdog window mode
- Can optionally cause system reset or interrupt request on timeout
- Reset by writing a software key to memory mapped register
- Enabled out of reset
- Configuration is protected by a software key or a write-once register

1.4.20 Cyclic redundancy check (CRC) module

The CRC computing unit is dedicated to the computation of CRC off-loading the CPU. The CRC features:

- Support for CRC-16-CCITT (x25 protocol):
— $X^{16} + X^{12} + X^5 + 1$
- Support for CRC-32 (Ethernet protocol):
— $X^{32} + X^{26} + X^{23} + X^{22} + X^{16} + X^{12} + X^{11} + X^{10} + X^8 + X^7 + X^5 + X^4 + X^2 + X + 1$
- Zero wait states for each write/read operations to the CRC_CFG and CRC_INP registers at the maximum frequency

1.4.21 Error correction status module (ECSM)

The ECSM provides a myriad of miscellaneous control functions regarding program-visible information about the platform configuration and revision levels, a reset status register, a software watchdog timer, wakeup control for exiting sleep modes, and information on platform memory errors reported by error-correcting codes and/or generic access error information for certain processor cores.

The Error Correction Status Module supports a number of miscellaneous control functions for the platform. The ECSM includes these features:

- Registers for capturing information on platform memory errors if error-correcting codes (ECC) are implemented
- For test purposes, optional registers to specify the generation of double-bit memory errors are enabled on the MPC5644A.

The sources of the ECC errors are:

- Flash
- SRAM
- Peripheral RAM (FlexRay, CAN, eTPU2 Parameter RAM)

1.4.22 External bus interface (EBI)

The MPC5644A device features an external bus interface that is available in 324 TEPBGA and calibration packages.

The EBI supports operation at frequencies of system clock /1, /2 and /4, with a maximum frequency support of 80 MHz. Customers running the device at 120 MHz or 132 MHz will use the /2 divider, giving an EBI frequency of 60 MHz or 66 MHz. Customers running the device at 80 MHz will be able to use the /1 divider to have the EBI run at the full 80 MHz frequency.

Features include:

- 1.8 V to 3.3 V \pm 10% I/O (1.6 V to 3.6 V)
- Memory controller with support for various memory types
- 16-bit data bus, up to 22-bit address bus
- Pin muxing included to support 32-bit muxed bus
- Selectable drive strength
- Configurable bus speed modes
- Bus monitor
- Configurable wait states

1.4.23 Calibration EBI

The Calibration EBI controls data transfer across the crossbar switch to/from memories or peripherals attached to the VertiCal connector in the calibration address space. The Calibration EBI is only available in the VertiCal Calibration System.

Features include:

- 1.8 V to 3.3 V \pm 10% I/O (1.6 V to 3.6 V)
- Memory controller supports various memory types
- 16-bit data bus, up to 22-bit address bus
- Pin muxing supports 32-bit muxed bus
- Selectable drive strength
- Configurable bus speed modes
- Bus monitor
- Configurable wait states

1.4.24 Power management controller (PMC)

The power management controller contains circuitry to generate the internal 3.3 V supply and to control the regulation of 1.2 V supply with an external NPN ballast transistor. It also contains low voltage inhibit (LVI) and power-on reset (POR) circuits for the 1.2 V supply, the 3.3 V supply, the 3.3 V/5 V supply of the closest I/O segment (VDDEH1) and the 5 V supply of the regulators (VDDREG).

1.4.25 Nexus port controller

The NPC (Nexus Port Controller) block provides real-time Nexus Class3+ development support capabilities for the MPC5644A Power Architecture-based MCU in compliance with the IEEE-ISTO 5001-2003 and 2010 standards. MDO port widths of 4 pins and 12 pins are available in all packages.

1.4.26 JTAG

The JTAGC (JTAG Controller) block provides the means to test chip functionality and connectivity while remaining transparent to system logic when not in test mode. Testing is performed via a boundary scan technique, as defined in the IEEE 1149.1-2001 standard. All data input to and output from the JTAGC block is communicated in serial format. The JTAGC block is compliant with the IEEE 1149.1-2001 standard and supports the following features:

- IEEE 1149.1-2001 Test Access Port (TAP) interface 4 pins (TDI, TMS, TCK, and TDO)
- A 5-bit instruction register that supports the following IEEE 1149.1-2001 defined instructions:
 - BYPASS, IDCODE, EXTEST, SAMPLE, SAMPLE/PRELOAD, HIGHZ, CLAMP
- A 5-bit instruction register that supports the additional following public instructions:
 - ACCESS_AUX_TAP_NPC
 - ACCESS_AUX_TAP_ONCE
 - ACCESS_AUX_TAP_eTPU
 - ACCESS_CENSOR
- 3 test data registers to support JTAG Boundary Scan mode
 - Bypass register
 - Boundary scan register
 - Device identification register
- A TAP controller state machine that controls the operation of the data registers, instruction register and associated circuitry
- Censorship Inhibit Register

- 64-bit Censorship password register
- If the external tool writes a 64-bit password that matches the Serial Boot password stored in the internal flash shadow row, Censorship is disabled until the next system reset.

1.4.27 Development Trigger Semaphore (DTS)

MPC5644A devices include a system development feature, the Development Trigger Semaphore (DTS) module, that enables software to signal an external tool by driving a persistent (affected only by reset or an external tool) signal on an external device pin. There is a variety of ways this module can be used, including as a component of an external real-time data acquisition system

1.5 MPC5644A series architecture

1.5.1 Block diagram

[Figure 1](#) shows a top-level block diagram of the MPC5644A series.

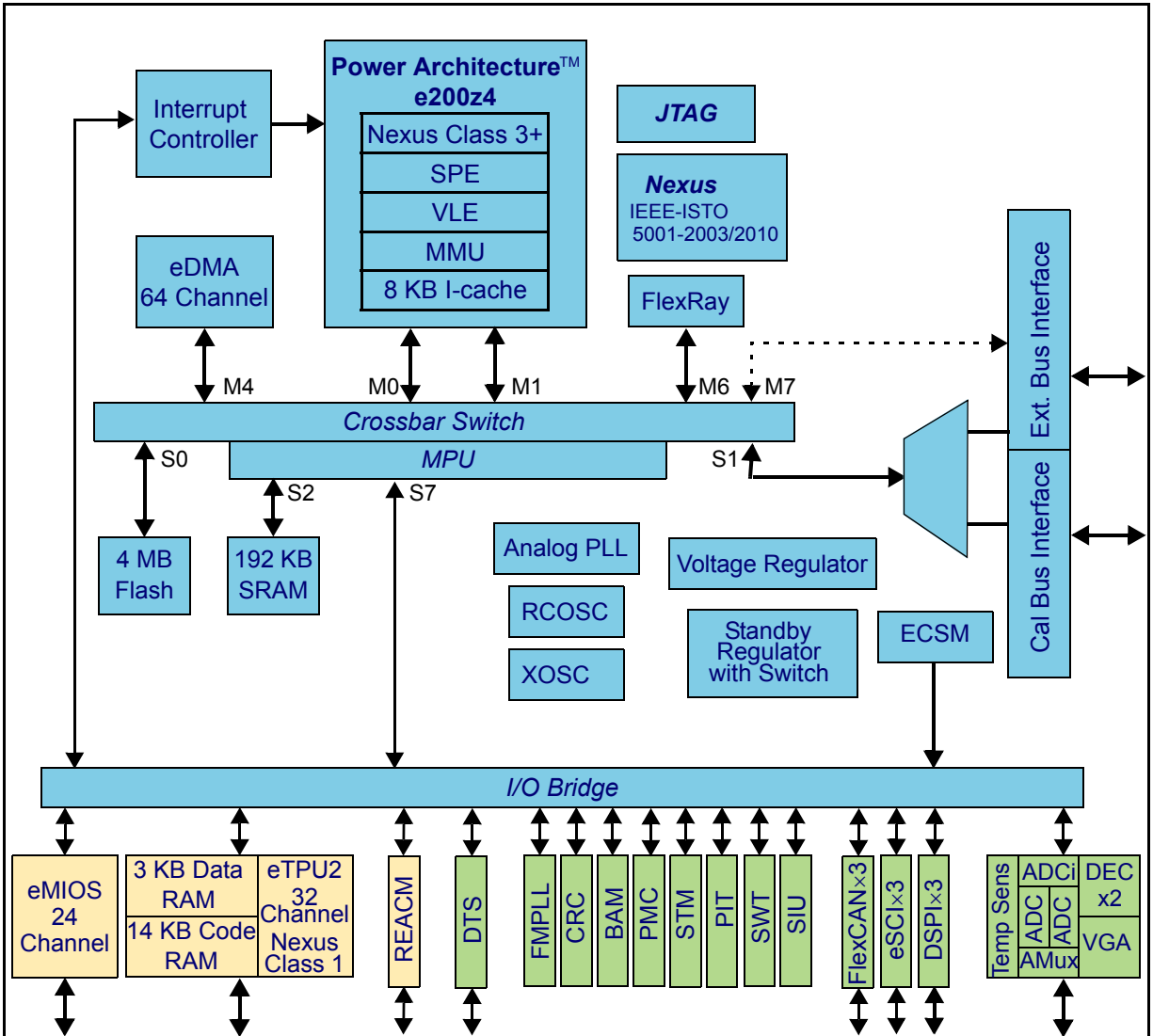

LEGEND

- | | |
|--|---|
| ADC – Analog to Digital Converter | JTAG – IEEE 1149.1 test controller |
| ADCi – ADC interface | MMU – Memory Management Unit |
| AMux – Analog Multiplexer | MPU – Memory Protection Unit |
| BAM – Boot Assist Module | PMC – Power Management Controller |
| CRC – Cyclic Redundancy Check unit | PIT – Periodic Interrupt Timer |
| DEC – Decimation Filter | RCOSC – low-speed RC oscillator |
| DTS – Development Trigger Semaphore | REACM – Reaction module |
| DSPI – Deserial/Serial Peripheral Interface | SIU – System Integration Unit |
| EBI – External Bus Interface | SPE – Signal Processing Extension |
| ECSCM – Error Correction Status Module | SRAM – Static RAM |
| eDMA – Enhanced Direct Memory Access | STM – System Timer Module |
| eMIOS – Enhanced Modular Input Output System | SWT – Software Watchdog Timer |
| eSCI – Enhanced Serial Communications Interface | VGA – Variable Gain Amplifier |
| eTPU2 – Second gen. Enhanced Time Processing Unit | VLE – Variable Length (instruction) Encoding |
| FlexCAN – Controller Area Network (FlexCAN) | XOSC – XTAL Oscillator |
| FMPLL – Frequency-Modulated Phase Locked Loop | |

Figure 1. MPC5644A series block diagram

1.5.2 Block summary

Table 2 summarizes the functions of the blocks present on the MPC5644A series microcontrollers.

Table 2. MPC5644A series block summary

Block	Function
Boot assist module (BAM)	Block of read-only memory containing executable code that searches for user-supplied boot code and, if none is found, executes the BAM boot code resident in device ROM.
Calibration Bus interface	Transfers data across the crossbar switch to/from peripherals attached to the calibration system connector.
Controller area network (FlexCAN)	Supports the standard CAN communications protocol.
Crossbar switch (XBAR)	Internal busmaster.
Cyclic redundancy check (CRC)	CRC checksum generator.
Deserial serial peripheral interface (DSPI)	Provides a synchronous serial interface for communication with external devices.
e200z4 core	Executes programs and interrupt handlers.
Enhanced direct memory access (eDMA)	Performs complex data movements with minimal intervention from the core.
Enhanced modular input-output system (eMIOS)	Provides the functionality to generate or measure events.
Enhanced queued analog-to-digital converter (eQADC)	Provides accurate and fast conversions for a wide range of applications.
Enhanced serial communication interface (eSCI)	Provides asynchronous serial communication capability with peripheral devices and other microcontroller units.
Enhanced time processor unit (eTPU2)	Second-generation co-processor processes real-time input events, performs output waveform generation, and accesses shared data without host intervention.
Error Correction Status Module (ECSM)	The Error Correction Status Module supports a number of miscellaneous control functions for the platform, and includes registers for capturing information on platform memory errors if error-correcting codes (ECC) are implemented
External bus interface (EBI)	Enables expansion of internal bus to enable connection of external memory or peripherals.
Flash memory	Provides storage for program code, constants, and variables.
FlexRay	Provides high-speed distributed control for advanced automotive applications.
Interrupt controller (INTC)	Provides priority-based preemptive scheduling of interrupt requests.
JTAG controller	Provides the means to test chip functionality and connectivity while remaining transparent to system logic when not in test mode.
Memory protection unit (MPU)	Provides hardware access control for all memory references generated.
Nexus port controller (NPC)	Provides real-time development support capabilities in compliance with the IEEE-ISTO 5001-2003 standard.

Table 2. MPC5644A series block summary (continued)

Block	Function
Reaction Module (REACM)	Works in conjunction with the eQADC and eTPU2 to increase system performance by removing the CPU from the current control loop.
System Integration Unit (SIU)	Controls MCU reset configuration, pad configuration, external interrupt, general purpose I/O (GPIO), internal peripheral multiplexing, and the system reset operation.
Static random-access memory (SRAM)	Provides storage for program code, constants, and variables.
System timers	Includes periodic interrupt timer with real-time interrupt; output compare timer and system watchdog timer.
Temperature sensor	Provides the temperature of the device as an analog value.

2 Pinout and signal description

This section contains the pinouts for all production packages for the MPC5644A family of devices.

CAUTION

Any pins labeled “NC” are to be left unconnected. Any connection to an external circuit or voltage may cause unpredictable device behavior or damage.

2.1 176 LQFP pinout

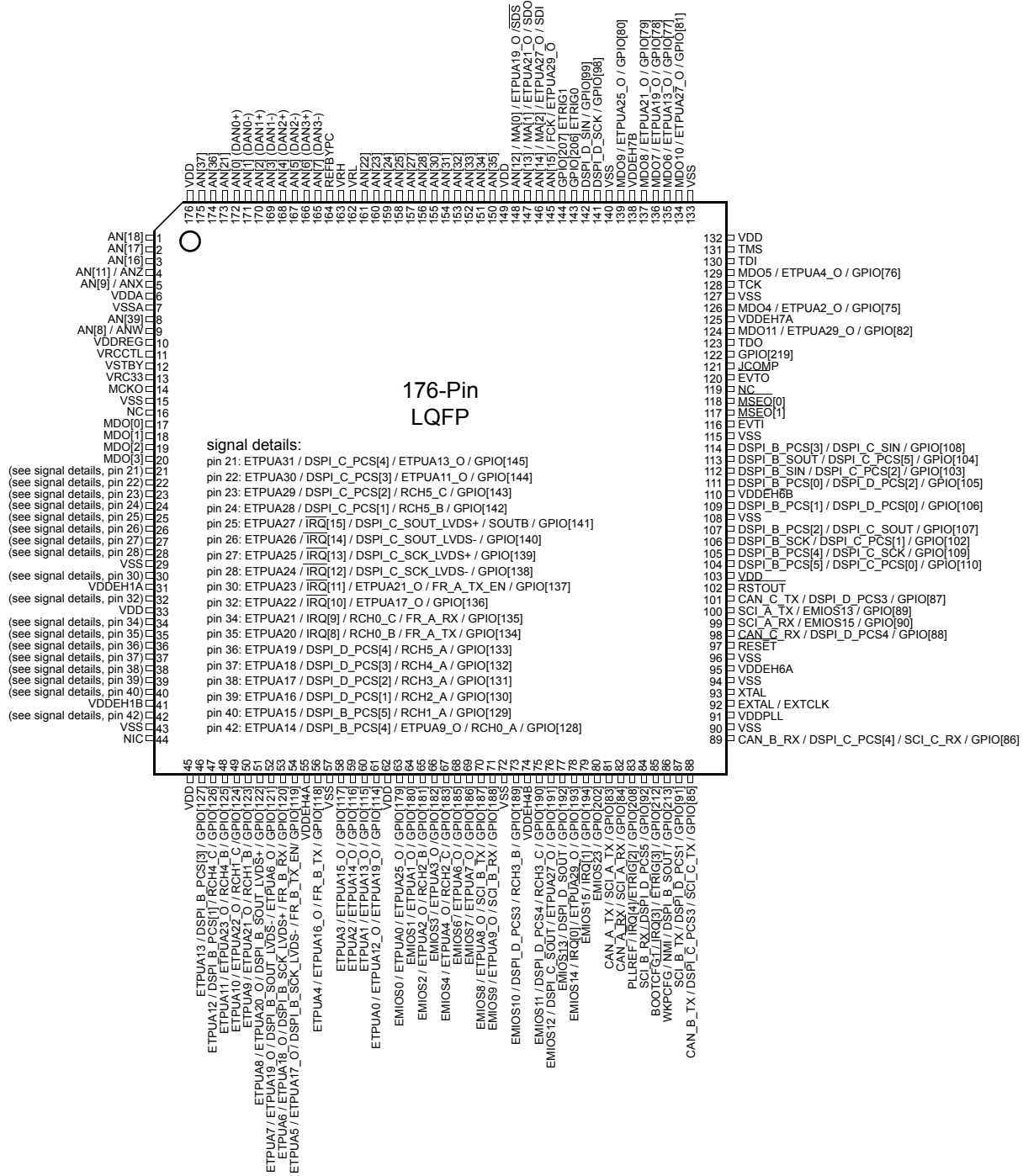

Figure 2. 176-pin LQFP pinout (top view)

2.2 208 MAP BGA ballmap

	1	2	3	4	5	6	7	8	9	10	11	12	13														
A	VSS	AN9	AN11	VDDA1	VSSA1	AN1	AN5	VRH	VRL	AN27	VSSA0	AN12-SDS	MDO2														
B	VDD	VSS	AN8	AN21	AN0	AN4	REFBYPC	AN22	AN25	AN28	VDDA0	AN13-SDO	MDO3														
C	VSTBY	VDD	VSS	AN17	AN34	AN16	AN3	AN7	AN23	AN32	AN33	AN14-SDI	AN15-FCK														
D	VRC33	AN39	VDD	VSS	AN18	AN2	AN6	AN24	AN30	AN31	AN35	VDDEH7	VSS														
E	ETPUA30	ETPUA31	AN37	VDD									NC														
F	ETPUA28	ETPUA29	ETPUA26	AN36									VDDEH6AB														
G	ETPUA24	ETPUA27	ETPUA25	ETPUA21	<table border="1" style="margin-left: auto; margin-right: auto;"> <tr> <td>VSS</td> <td>VSS</td> <td>VSS</td> <td>VSS</td> </tr> <tr> <td>VSS</td> <td>VSS</td> <td>VSS</td> <td>VSS</td> </tr> <tr> <td>VSS</td> <td>VSS</td> <td>VSS</td> <td>VSS</td> </tr> <tr> <td>VSS</td> <td>VSS</td> <td>VSS</td> <td>VSS</td> </tr> </table>				VSS	VSS	VSS	VSS	VSS	VSS	VSS	VSS	VSS	VSS	VSS	VSS	VSS	VSS	VSS	VSS			DSPI_B_SOUT
VSS	VSS	VSS	VSS																								
VSS	VSS	VSS	VSS																								
VSS	VSS	VSS	VSS																								
VSS	VSS	VSS	VSS																								
H	ETPUA23	ETPUA22	ETPUA17	ETPUA18			GPIO99																				
J	ETPUA20	ETPUA19	ETPUA14	ETPUA13			DSPI_B_PCS5																				
K	ETPUA16	ETPUA15	ETPUA7	VDDEH1AB			CAN_C_TX																				
L	ETPUA12	ETPUA11	ETPUA6	TCRCLKA			SCI_B_TX																				
M	ETPUA10	ETPUA9	ETPUA1	ETPUA5			SCI_B_RX																				
N	ETPUA8	ETPUA4	ETPUA0	VSS	VDD	VRC33	EMIOS2	EMIOS10	VDDEH4AB	EMIOS12	MDO7_ETPUA19_O	VRC33	VSS ¹														
P	ETPUA3	ETPUA2	VSS	VDD	GPIO207	NC	EMIOS6	EMIOS8	MDO11_ETPUA29_O	MDO4_ETPUA2_O	MDO8_ETPUA21_O	CAN_A_TX	VDD														
R	NC	VSS	VDD	GPIO206	EMIOS4	EMIOS3	EMIOS9	EMIOS11	EMIOS14	MDO10_ETPUA27_O	EMIOS23	CAN_A_RX	CAN_B_RX														
T	VSS	VDD	NC	EMIOS0	EMIOS1	GPIO219	MDO9_ETPUA25_O	EMIOS13	EMIOS15	MDO5_ETPUA4_O	MDO6_ETPUA13_O	CAN_B_TX	VDDE5														

¹ This pin (N13) should be tied low.

Figure 3. 208-pin MAPBGA package ballmap (viewed from above)

2.3 324 TEPBGA ballmap

	1	2	3	4	5	6	7	8	9	10
A	VSS	VDD	AN16	AN17	AN37	VDDA1	VSSA1	AN23	AN25	VRH
B	VRC33	VSS	VDD	AN18	AN36	AN21	AN4	AN5	AN24	REFBY
C	AN11	AN9 ANX	VSS	VDD	AN20	AN0	AN1	AN6	AN7	AN27
D	AN10 ANY	AN39	AN38	VSS	VDD	AN19	AN2	AN3	AN22	AN26
E	AN8 ANW	VSSA0	VDDA0	VSTBY						
F	MCKO	VRCCTL	MDO0	VDDREG						
G	CS0	MDO1	MDO2	MDO3						
H	CS1	CS2	OE	CS3						
J	WE1	WE0	BDIP	RD_WR					VSS	VSS
K	ETPUA31	TA	TS	VDDEH1AB					VSS	VSS
L	ETPUA27	ETPUA26	ETPUA29	ETPUA30					VSS	VSS

Figure 4. 324-pin TEPBGA package ballmap (northwest, viewed from above)

	12	13	14	15	16	17	18	19	20	21
	AN34	AN14-SDI	AN15-FCK	GPIO203	DSPI_A_PCS5	DSPI_A_SOUT	MDO8_ETPUA21_O	MDO10_ETPUA27_O	VDD	VDD
	AN33	AN13-SDO	GPIO207	GPIO99	DSPI_A_PCS4	DSPI_A_SIN	MDO7_ETPUA19_O	MDO4_ETPUA2_O	MDO5_ETPUA4_O	VSS
	AN32	AN12-SDS	GPIO206	GPIO98	DSPI_A_PCS1	DSPI_A_SCK	MDO6_ETPUA13_O	MDO11_ETPUA29_O	VSS	VDDEH7
	AN31	AN35	GPIO204	VDDEH7	DSPI_A_PCS0	VSS	MDO9_ETPUA25_O	VSS	VDDEH7	TCK
								VDDEH7	TMS	TDO
								VDDEH7	JCOMP	VSS
								RDY	EVTO	MSEO0
								VDDEH7	EVTI	VSS
								DSPI_B_SOUT	DSPI_B_PCS3	DSPI_B_PCS0
								NC	DSPI_B_PCS4	DSPI_B_SCK
								DSPI_B_PCS5	NC	VSS
	VSS	VSS	VDDEH7							
	VSS	VSS	VSS							
	VSS	VSS	VSS							

Figure 6. 324-pin TEPBGA package ballmap (northeast, viewed from above)

VSS	VSS	VSS
VSS	VSS	VSS
VSS	VSS	VSS

VRC33	NC	NC
NC	SCI_A_TX	VSS
CAN_C_TX	SCI_A_RX	RSTOUT
NC	NC	NC
VSS	BOOTCFG0	VSS ¹
VDDEH6AB	PLLCFG1	BOOTCFG1
SCI_C_RX	CAN_C_RX	PLLREF

ETPUA1	EMIOS1	VDDEH4AB	EMIOS8	EMIOS15	EMIOS16	EMIOS23	SCI_C_TX	VDD	CAN_B_RX
ETPUA0	EMIOS2	EMIOS5	EMIOS9	EMIOS14	EMIOS17	EMIOS22	CAN_A_RX	VSS	VDD
EMIOS0	EMIOS3	EMIOS6	EMIOS10	EMIOS13	EMIOS18	EMIOS21	VDDEH4AB	WKPCFG	VSS
TCRCLKA	EMIOS4	EMIOS7	EMIOS11	EMIOS12	EMIOS19	EMIOS20	CAN_A_TX	SCI_B_RX	SCI_B_TX
12	13	14	15	16	17	18	19	20	21

¹ This pin (T21) should be tied low.

Figure 7. 324-pin TEPBGA package ballmap (southeast, viewed from above)

2.4 Signal summary

Table 3. MPC5644A signal properties

Name	Function ¹	P A G ²	PCR PA Field ³	PCR ⁴	I/O Type	Voltage ⁵ / Pad Type ⁶	Status ⁷		176
							During Reset	After Reset	
GPIO									
EMIOS14 ⁸ GPIO[203]	eMIOS channel GPIO	P G	01 00	203	O I/O	VDDEH7 Slow	— / Up	— / Up	—
EMIOS15 ⁸ GPIO[204]	eMIOS channel GPIO	P G	01 00	204	O I/O	VDDEH7 Slow	— / Up	— / Up	—
GPIO[206] ETRIG0	GPIO / eQADC Trigger Input	G	00	206	I/O ⁹	VDDEH7 Slow ¹⁰	— / Up	— / Up	143
GPIO[207] ETRIG1	GPIO / eQADC Trigger Input	G	00	207	I/O ⁹	VDDEH7 Slow	— / Up	— / Up	144
GPIO[219]	GPIO	G	—	219 ¹¹	I/O	VDDEH7 MultiV ¹²	— / Up	— / Up	122
Reset / Configuration									
$\overline{\text{RESET}}$	External Reset Input	P	—	—	I	VDDEH6 Slow	$\overline{\text{RESET}}$ / Up	$\overline{\text{RESET}}$ / Up	97
$\overline{\text{RSTOUT}}$	External Reset Output	P	01	230	O	VDDEH6 Slow	$\overline{\text{RSTOUT}}$ / Down	$\overline{\text{RSTOUT}}$ / Down	102
PLLREF $\overline{\text{IRQ}}[4]$ ETRIG2 GPIO[208]	FMPLL Mode Selection External Interrupt Request eQADC Trigger Input GPIO	P A1 A2 G	001 010 100 000	208	I I I I/O	VDDEH6 Slow	— / Up	PLLREF / Up	83
PLLCFG1 ¹³ $\overline{\text{IRQ}}[5]$ DSPI_D_SOUT GPIO[209]	— External interrupt request DSPI D data output GPIO	— A1 A2 G	— 010 100 000	209	— I O I/O	VDDEH6 Medium	— / Up	— / Up	—
RSTCFG GPIO[210]	RSTCFG GPIO	P G	01 00	210	I I/O	VDDEH6 Slow	— / Down	—	—
BOOTCFG[0] $\overline{\text{IRQ}}[2]$ GPIO[211]	Boot Config. Input External Interrupt Request GPIO	P A1 G	01 10 00	211	I I I/O	VDDEH6 Slow	— / Down	BOOTCFG[0] / Down	—

Table 3. MPC5644A signal properties (continued)

Name	Function ¹	P A G ²	PCR PA Field ³	PCR ⁴	I/O Type	Voltage ⁵ / Pad Type ⁶	Status ⁷		176
							During Reset	After Reset	
BOOTCFG[1] IRQ[3] ETRIG3 GPIO[212]	Boot Config. Input External Interrupt Request eQADC Trigger Input GPIO	P A1 A2 G	001 010 100 000	212	I I I I/O	VDDEH6 Slow	— / Down	BOOTCFG[1] / Down	85
WKPCFG NMI DSPI_B_SOUT GPIO[213]	Weak Pull Config. Input Non-Maskable Interrupt DSPI D data output GPIO	P A1 A2 G	001 010 100 000	213	I I O I/O	VDDEH6 Medium	— / Up	WKPCFG / Up	86
External Bus Interface									
CS[0] ADDR[8] GPIO[0]	External chip selects External address bus GPIO	P A1 G	01 10 00	0	O I/O I/O	VDDE2 Fast	— / Up	— / Up	—
CS[1] ADDR9 GPIO[1]	External chip selects External address bus GPIO	P A1 G	01 10 00	1	O I/O I/O	VDDE2 Fast	— / Up	— / Up	—
CS[2] ADDR10 WE[2]/BE[2] CAL_WE[2]/BE[2] GPIO[2]	External chip selects External address bus Write/byte enable Cal. bus write/byte enable GPIO	P A1 A2 A3 G	0001 0010 0100 1000 0000	2	O I/O O O I/O	VDDE2 Fast	— / Up	— / Up	—
CS[3] ADDR11 WE[3]/BE[3] CAL_WE[3]/BE[3] GPIO[3]	External chip selects External address bus Write/byte enable Cal bus write/byte enable GPIO	P A1 A2 A3 G	0001 0010 0100 1000 0000	3	O I/O O O I/O	VDDE2 Fast	— / Up	— / Up	—
ADDR12 GPIO[8]	External address bus GPIO	P G	01 00	8	I/O I/O	VDDE3 Fast	— / Up	— / Up	—
ADDR13 WE[2] GPIO[9]	External address bus Write/byte enable GPIO	P A2 G	001 100 000	9	I/O O I/O	VDDE3 Fast	— / Up	— / Up	—
ADDR14 WE[3] GPIO[10]	External address bus Write/byte enables GPIO	P A2 G	001 100 000	10	I/O O I/O	VDDE3 Fast	— / Up	— / Up	—
ADDR15 GPIO[11]	External address bus GPIO	P G	01 00	11	I/O I/O	VDDE3 Fast	— / Up	— / Up	—

Table 3. MPC5644A signal properties (continued)

Name	Function ¹	P A G ²	PCR PA Field ³	PCR ⁴	I/O Type	Voltage ⁵ / Pad Type ⁶	Status ⁷		176
							During Reset	After Reset	
ADDR16 FR_A_TX DATA16 GPIO[12]	External address bus Flexray TX data channel A External data bus GPIO	P A1 A2 G	001 010 100 000	12	I/O O I/O I/O	VDDE-EH Medium	— / Up	— / Up	—
ADDR17 FR_A_TX_EN DATA17 GPIO[13]	External address bus FlexRay ch. A TX data enable External data bus GPIO	P A1 A2 G	001 010 100 000	13	I/O O I/O I/O	VDDE-EH Medium	— / Up	— / Up	—
ADDR18 FR_A_RX DATA18 GPIO[14]	External address bus Flexray RX data ch. A External data bus GPIO	P A1 A2 G	001 010 100 000	14	I/O I I/O I/O	VDDE-EH Medium	— / Up	— / Up	—
ADDR19 FR_B_TX DATA19 GPIO[15]	External address bus Flexray TX data ch. B External data bus GPIO	P A1 A2 G	001 010 100 000	15	I/O O I/O I/O	VDDE-EH Medium	— / Up	— / Up	—
ADDR20 FR_B_TX_EN DATA20 GPIO[16]	External address bus Flexray TX data enable for ch. B External data bus GPIO	P A1 A2 G	001 010 100 000	16	I/O O I/O I/O	VDDE-EH Medium	— / Up	— / Up	—
ADDR21 FR_B_RX DATA21 GPIO[17]	External address bus Flexray RX data channel B External data bus GPIO	P A1 A2 G	001 010 100 000	17	I/O I I/O I/O	VDDE-EH Medium	— / Up	— / Up	—
ADDR22 DATA22 GPIO[18]	External address bus External data bus GPIO	P A2 G	001 100 000	18	I/O I/O I/O	VDDE-EH Medium	— / Up	— / Up	—
ADDR23 DATA23 GPIO[19]	External address bus External data bus GPIO	P A2 G	001 100 000	19	I/O I/O I/O	VDDE-EH Medium	— / Up	— / Up	—
ADDR24 DATA24 GPIO[20]	External address bus External data bus GPIO	P A2 G	001 100 000	20	I/O I/O I/O	VDDE-EH Medium	— / Up	— / Up	—
ADDR25 DATA25 GPIO[21]	External address bus External data bus GPIO	P A2 G	001 100 000	21	I/O I/O I/O	VDDE-EH Medium	— / Up	— / Up	—

Table 3. MPC5644A signal properties (continued)

Name	Function ¹	P A G ²	PCR PA Field ³	PCR ⁴	I/O Type	Voltage ⁵ / Pad Type ⁶	Status ⁷		176
							During Reset	After Reset	
ADDR26 DATA26 GPIO[22]	External address bus External data bus GPIO	P A2 G	001 100 000	22	I/O I/O I/O	VDDE-EH Medium	— / Up	— / Up	—
ADDR27 DATA27 GPIO[23]	External address bus External data bus GPIO	P A2 G	001 100 000	23	I/O I/O I/O	VDDE-EH Medium	— / Up	— / Up	—
ADDR28 DATA28 GPIO[24]	External address bus External data bus GPIO	P A2 G	001 100 000	24	I/O I/O I/O	VDDE-EH Medium	— / Up	— / Up	—
ADDR29 DATA29 GPIO[25]	External address bus External data bus GPIO	P A2 G	001 100 000	25	I/O I/O I/O	VDDE-EH Medium	— / Up	— / Up	—
ADDR30 ADDR6 ⁸ DATA30 GPIO[26]	External address bus External address bus External data bus GPIO	P A1 A2 G	001 010 100 000	26	I/O O I/O I/O	VDDE-EH Medium	— / Up	— / Up	—
ADDR31 ADDR7 ⁸ DATA31 GPIO[27]	External address bus External address bus External data bus GPIO	P A1 A2 G	001 010 100 000	27	I/O O I/O I/O	VDDE-EH Medium	— / Up	— / Up	—
DATA0 ADDR16 GPIO[28]	External data bus External address bus GPIO	P A1 G	001 010 000	28	I/O I/O I/O	VDDE5 Fast	— / Up	— / Up	—
DATA1 ADDR17 GPIO[29]	External data bus External address bus GPIO	P A1 G	001 010 000	29	I/O I/O I/O	VDDE5 Fast	— / Up	— / Up	—
DATA2 ADDR18 GPIO[30]	External data bus External address bus GPIO	P A1 G	001 010 000	30	I/O I/O I/O	VDDE5 Fast	— / Up	— / Up	—
DATA3 ADDR19 GPIO[31]	External data bus External address bus GPIO	P A1 G	001 010 000	31	I/O I/O I/O	VDDE5 Fast	— / Up	— / Up	—
DATA4 ADDR20 GPIO[32]	External data bus External address bus GPIO	P A1 G	001 010 000	32	I/O I/O I/O	VDDE5 Fast	— / Up	— / Up	—

Table 3. MPC5644A signal properties (continued)

Name	Function ¹	P A G ²	PCR PA Field ³	PCR ⁴	I/O Type	Voltage ⁵ / Pad Type ⁶	Status ⁷		176
							During Reset	After Reset	
DATA5 ADDR21 GPIO[33]	External data bus External address bus GPIO	P A1 G	001 010 000	33	I/O I/O I/O	VDDE5 Fast	— / Up	— / Up	—
DATA6 ADDR22 GPIO[34]	External data bus External address bus GPIO	P A1 G	001 010 000	34	I/O I/O I/O	VDDE5 Fast	— / Up	— / Up	—
DATA7 ADDR23 GPIO[35]	External data bus External address bus GPIO	P A1 G	001 010 000	35	I/O I/O I/O	VDDE5 Fast	— / Up	— / Up	—
DATA8 ADDR24 GPIO[36]	External data bus External address bus GPIO	P A1 G	001 010 000	36	I/O I/O I/O	VDDE5 Fast	— / Up	— / Up	—
DATA9 ADDR25 GPIO[37]	External data bus External address bus GPIO	P A1 G	001 010 000	37	I/O I/O I/O	VDDE5 Fast	— / Up	— / Up	—
DATA10 ADDR26 GPIO[38]	External data bus External address bus GPIO	P A1 G	001 010 000	38	I/O I/O I/O	VDDE5 Fast	— / Up	— / Up	—
DATA11 ADDR27 GPIO[39]	External data bus External address bus GPIO	P A1 G	001 010 000	39	I/O I/O I/O	VDDE5 Fast	— / Up	— / Up	—
DATA12 ADDR28 GPIO[40]	External data bus External address bus GPIO	P A1 G	001 010 000	40	I/O I/O I/O	VDDE5 Fast	— / Up	— / Up	—
DATA13 ADDR29 GPIO[41]	External data bus External address bus GPIO	P A1 G	001 010 000	41	I/O I/O I/O	VDDE5 Fast	— / Up	— / Up	—
DATA14 ADDR30 GPIO[42]	External data bus External address bus GPIO	P A1 G	001 010 000	42	I/O I/O I/O	VDDE5 Fast	— / Up	— / Up	—
DATA15 ADDR31 GPIO[43]	External data bus External address bus GPIO	P A1 G	001 010 000	43	I/O I/O I/O	VDDE5 Fast	— / Up	— / Up	—
RD_ $\overline{\text{WR}}$ GPIO[62]	External read/write GPIO	P G	01 00	62	I/O I/O	VDDE2 Fast	— / Up	— / Up	—

Table 3. MPC5644A signal properties (continued)

Name	Function ¹	P A G ²	PCR PA Field ³	PCR ⁴	I/O Type	Voltage ⁵ / Pad Type ⁶	Status ⁷		176
							During Reset	After Reset	
BDIP GPIO[63]	External burst data in progress GPIO	P G	01 00	63	O I/O	VDDE2 Fast	— / Up	— / Up	—
WE[0]/BE[0] GPIO[64]	External write/byte enable GPIO	P G	01 00	64	O I/O	VDDE2 Fast	— / Up	— / Up	—
WE[1]/BE[1] GPIO[65]	External write/byte enable GPIO	P G	01 00	65	O I/O	VDDE2 Fast	— / Up	— / Up	—
OE GPIO[68]	External output enable GPIO	P G	01 00	68	O I/O	VDDE2 Fast	— / Up	— / Up	—
TS ALE GPIO[69]	External transfer start Address latch enable GPIO[69]	P A1 G	001 010 000	69	I/O O I/O	VDDE2 Fast	— / Up	— / Up	—
TA TS ⁸ GPIO[70]	External transfer acknowledge External transfer start GPIO	P A1 G	001 010 000	70	I/O O I/O	VDDE2 Fast	— / Up	— / Up	—
Calibration Bus									
CAL_CS0	Calibration chip select	P	01	336	O	VDDE12 Fast		— / —	—
CAL_CS2 CAL_ADDR[10] CAL_WE[2]/BE[2]	Calibration chip select Calibration address bus Calibration write/byte enable	P A A2	001 010 100	338	O I/O O	VDDE12 Fast		— / —	—
CAL_CS3 CAL_ADDR[11] CAL_WE[3]/BE[3]	Calibration chip select Calibration address bus Calibration write/byte enable	P A A2	001 010 100	339	O I/O O	VDDE12 Fast		— / —	—
CAL_ADDR[12] CAL_WE[2]/BE[2]	Calibration address bus Calibration write/byte enable	P A	01 10	340	I/O O	VDDE12 Fast		— / —	—
CAL_ADDR[13] CAL_WE[3]/BE[3]	Calibration address bus Calibration write/byte enable	P A	01 10	340	I/O O	VDDE12 Fast		— / —	—
CAL_ADDR[14] CAL_DATA[31]	Calibration address bus Calibration data bus	P A	01 10	340	I/O I/O	VDDE12 Fast		— / —	—
CAL_ADDR[15] CAL_ALE	Calibration address bus Calibration address latch enable	P A1	01 10	340	I/O O	VDDE12 Fast		— / —	—
CAL_ADDR[16] CAL_DATA[16]	Calibration address bus Calibration data bus	P A	01 10	345	I/O I/O	VDDE12 Fast		— / —	—

Table 3. MPC5644A signal properties (continued)

Name	Function ¹	P A G ²	PCR PA Field ³	PCR ⁴	I/O Type	Voltage ⁵ / Pad Type ⁶	Status ⁷		176
							During Reset	After Reset	
CAL_ADDR[17] CAL_DATA[17]	Calibration address bus Calibration data bus	P A	01 10	345	I/O I/O	VDDE12 Fast		— / —	—
CAL_ADDR[18] CAL_DATA[18]	Calibration address bus Calibration data bus	P A	01 10	345	I/O I/O	VDDE12 Fast		— / —	—
CAL_ADDR[19] CAL_DATA[19]	Calibration address bus Calibration data bus	P A	01 10	345	I/O I/O	VDDE12 Fast		— / —	—
CAL_ADDR[20] CAL_DATA[20]	Calibration address bus Calibration data bus	P A	01 10	345	I/O I/O	VDDE12 Fast		— / —	—
CAL_ADDR[21] CAL_DATA[21]	Calibration address bus Calibration data bus	P A	01 10	345	I/O I/O	VDDE12 Fast		— / —	—
CAL_ADDR[22] CAL_DATA[22]	Calibration address bus Calibration data bus	P A	01 10	345	I/O I/O	VDDE12 Fast		— / —	—
CAL_ADDR[23] CAL_DATA[23]	Calibration address bus Calibration data bus	P A	01 10	345	I/O I/O	VDDE12 Fast		— / —	—
CAL_ADDR[24] CAL_DATA[24]	Calibration address bus Calibration data bus	P A	01 10	345	I/O I/O	VDDE12 Fast		— / —	—
CAL_ADDR[25] CAL_DATA[25]	Calibration address bus Calibration data bus	P A	01 10	345	I/O I/O	VDDE12 Fast		— / —	—
CAL_ADDR[26] CAL_DATA[26]	Calibration address bus Calibration data bus	P A	01 10	345	I/O I/O	VDDE12 Fast		— / —	—
CAL_ADDR[27] CAL_DATA[27]	Calibration address bus Calibration data bus	P A	01 10	345	I/O I/O	VDDE12 Fast		— / —	—
CAL_ADDR[28] CAL_DATA[28]	Calibration address bus Calibration data bus	P A	01 10	345	I/O I/O	VDDE12 Fast		— / —	—
CAL_ADDR[29] CAL_DATA[29]	Calibration address bus Calibration data bus	P A	01 10	345	I/O I/O	VDDE12 Fast		— / —	—
CAL_ADDR[30] CAL_DATA[30]	Calibration address bus Calibration data bus	P A	01 10	345	I/O I/O	VDDE12 Fast		— / —	—
CAL_DATA[0]	Calibration data bus	P	01	341	I/O	VDDE12 Fast	— / Up	— / Up	—
CAL_DATA[1]	Calibration data bus	P	01	341	I/O	VDDE12 Fast	— / Up	— / Up	—

Table 3. MPC5644A signal properties (continued)

Name	Function ¹	P A G ²	PCR PA Field ³	PCR ⁴	I/O Type	Voltage ⁵ / Pad Type ⁶	Status ⁷		176
							During Reset	After Reset	
CAL_DATA[2]	Calibration data bus	P	01	341	I/O	VDDE12 Fast	— / Up	— / Up	—
CAL_DATA[3]	Calibration data bus	P	01	341	I/O	VDDE12 Fast	— / Up	— / Up	—
CAL_DATA[4]	Calibration data bus	P	01	341	I/O	VDDE12 Fast	— / Up	— / Up	—
CAL_DATA[5]	Calibration data bus	P	01	341	I/O	VDDE12 Fast	— / Up	— / Up	—
CAL_DATA[6]	Calibration data bus	P	01	341	I/O	VDDE12 Fast	— / Up	— / Up	—
CAL_DATA[7]	Calibration data bus	P	01	341	I/O	VDDE12 Fast	— / Up	— / Up	—
CAL_DATA[8]	Calibration data bus	P	01	341	I/O	VDDE12 Fast	— / Up	— / Up	—
CAL_DATA[9]	Calibration data bus	P	01	341	I/O	VDDE12 Fast	— / Up	— / Up	—
CAL_DATA[10]	Calibration data bus	P	01	341	I/O	VDDE12 Fast	— / Up	— / Up	—
CAL_DATA[11]	Calibration data bus	P	01	341	I/O	VDDE12 Fast	— / Up	— / Up	—
CAL_DATA[12]	Calibration data bus	P	01	341	I/O	VDDE12 Fast	— / Up	— / Up	—
CAL_DATA[13]	Calibration data bus	P	01	341	I/O	VDDE12 Fast	— / Up	— / Up	—
CAL_DATA[14]	Calibration data bus	P	01	341	I/O	VDDE12 Fast	— / Up	— / Up	—
CAL_DATA[15]	Calibration data bus	P	01	341	I/O	VDDE12 Fast	— / Up	— / Up	—
CAL_RD_WR	Calibration read/write enable	P	01	342	O	VDDE12 Fast		— / —	—
CAL_WE[0]/BE[0]	Calibration write/byte enable	P	01	342	O	VDDE12 Fast		— / —	—

Table 3. MPC5644A signal properties (continued)

Name	Function ¹	P A G ²	PCR PA Field ³	PCR ⁴	I/O Type	Voltage ⁵ / Pad Type ⁶	Status ⁷		176
							During Reset	After Reset	
CAL_WE[1]/BE[1]	Calibration write/byte enable	P	01	342	O	VDDE12 Fast		— / —	—
CAL_OE	Calibration output enable	P	01	342	O	VDDE12 Fast		— / —	—
CAL_TS CAL_ALE	Calibration transfer start Address Latch Enable	P A	01 10	343	O O	VDDE12 Fast		— / —	—
CAL_MDO[4]	Calibration Nexus Message Data Out	P	01	—	O	VDDE12 Fast	—	CAL_MDO[4] / —	—
CAL_MDO[5]	Calibration Nexus Message Data Out	P	01	—	O	VDDE12 Fast	—	CAL_MDO[5] / —	—
CAL_MDO[6]	Calibration Nexus Message Data Out	P	01	—	O	VDDE12 Fast	—	CAL_MDO[6] / —	—
CAL_MDO[7]	Calibration Nexus Message Data Out	P	01	—	O	VDDE12 Fast	—	CAL_MDO[7] / —	—
CAL_MDO[8]	Calibration Nexus Message Data Out	P	01	—	O	VDDE12 Fast	—	CAL_MDO[8] / —	—
CAL_MDO[9]	Calibration Nexus Message Data Out	P	01	—	O	VDDE12 Fast	—	CAL_MDO[9] / —	—
CAL_MDO[10]	Calibration Nexus Message Data Out	P	01	—	O	VDDE12 Fast	—	CAL_MDO[10] / —	—
CAL_MDO[11]	Calibration Nexus Message Data Out	P	01	—	O	VDDE12 Fast	—	CAL_MDO[11] / —	—
NEXUS									
EVTI	Nexus event in	P	01	231	I	VDDEH7 MultiV ^{12,14}	— / Up	EVTI / Up	116
EVTO	Nexus event out	P	01	227	O	VDDEH7 MultiV ^{12,14,15}	—	EVTO / —	120
MCKO	Nexus message clock out	P	—	219 ¹¹	O	VRC33 Fast	—	MCKO / —	14
MDO0 ¹⁶	Nexus message data out	P	01	220	O	VRC33 Fast	—	MDO[0] / —	17
MDO1 ¹⁶	Nexus message data out	P	01	221	O	VRC33 Fast	—	MDO[1] / —	18

Table 3. MPC5644A signal properties (continued)

Name	Function ¹	P A G ²	PCR PA Field ³	PCR ⁴	I/O Type	Voltage ⁵ / Pad Type ⁶	Status ⁷		176
							During Reset	After Reset	
MDO2 ¹⁶	Nexus message data out	P	01	222	O	VRC33 Fast	—	MDO[2] / —	19
MDO3 ¹⁶	Nexus message data out	P	01	223	O	VRC33 Fast	—	MDO[3] / —	20
MDO4 ¹⁶ ETPUA2_O ⁸ GPIO[75]	Nexus message data out eTPU A channel (output only) GPIO[P A1 G	01 10 00	75	O O I/O	VDDEH7 MultiV ^{12,14}	—	— / —	126
MDO5 ¹⁶ ETPUA4_O ⁸ GPIO[76]	Nexus message data out eTPU A channel (output only) GPIO	P A1 G	01 10 00	76	O O I/O	VDDEH7 MultiV ^{12,14}	—	— / —	129
MDO6 ¹⁶ ETPUA13_O ⁸ GPIO[77]	Nexus message data out eTPU A channel (output only) GPIO	P A1 G	01 10 00	77	O O I/O	VDDEH7 MultiV ^{12,14}	—	— / —	135
MDO7 ¹⁶ ETPUA19_O ⁸ GPIO[78]	Nexus message data out eTPU A channel (output only) GPIO	P A1 G	01 10 00	78	O O I/O	VDDEH7 MultiV ^{12,14}	—	— / —	136
MDO8 ¹⁶ ETPUA21_O ⁸ GPIO[79]	Nexus message data out eTPU A channel (output only) GPIO	P A1 G	01 10 00	79	O O I/O	VDDEH7 MultiV ^{12,14}	—	— / —	137
MDO9 ¹⁶ ETPUA25_O ⁸ GPIO[80]	Nexus message data out eTPU A channel (output only) GPIO	P A1 G	01 10 00	80	O O I/O	VDDEH7 MultiV ^{12,14}	—	— / —	139
MDO10 ¹⁶ ETPUA27_O ⁸ GPIO[81]	Nexus message data out eTPU A channel (output only) GPIO	P A1 G	01 10 00	81	O O I/O	VDDEH7 MultiV ^{12,14}	—	— / —	134
MDO11 ¹⁶ ETPUA29_O ⁸ GPIO[82]	Nexus message data out eTPU A channel (output only) GPIO[82]	P A1 G	01 10 00	82	O O I/O	VDDEH7 MultiV ^{12,14}	—	— / —	124
MSEO[0] ¹⁶	Nexus message start/end out	P	01	224	O	VDDEH7 MultiV ^{12,14}	—	MSEO[0] / —	118
MSEO[1] ¹⁶	Nexus message start/end out	P	01	225	O	VDDEH7 MultiV ^{12,14}	—	MSEO[1] / —	117
RDY	Nexus ready output	P	01	226	O	VDDEH7 MultiV ^{12,14}	—	—	—
JTAG									

Table 3. MPC5644A signal properties (continued)

Name	Function ¹	P A G ²	PCR PA Field ³	PCR ⁴	I/O Type	Voltage ⁵ / Pad Type ⁶	Status ⁷		176
							During Reset	After Reset	
TCK	JTAG test clock input	P	01	—	I	VDDEH7 MultiV ¹²	TCK / Down	TCK / Down	128
TDI	JTAG test data input	P	01	232	I	VDDEH7 MultiV ¹²	TDI / Up	TDI / Up	130
TDO	JTAG test data output	P	01	228	O	VDDEH7 MultiV ¹²	TDO / Up	TDO / Up	123
TMS	JTAG test mode select input	P	01	—	I	VDDEH7 MultiV ¹²	TMS / Up	TMS / Up	131
JCOMP	JTAG TAP controller enable	P	01	—	I	VDDEH7 MultiV ¹²	JCOMP / Down	JCOMP / Down	121
FlexCAN									
CAN_A_TX SCI_A_TX GPIO[83]	FlexCAN A TX eSCI A TX GPIO	P A1 G	01 10 00	83	O O I/O	VDDEH6 Slow	— / Up	— / Up	81
CAN_A_RX SCI_A_RX GPIO[84]	FlexCAN A RX eSCI A RX GPIO	P A1 G	01 10 00	84	I I I/O	VDDEH6 Slow	— / Up	— / Up	82
CAN_B_TX DSPI_C_PCS[3] SCI_C_TX GPIO[85]	FlexCAN B TX DSPI C peripheral chip select eSCI C TX GPIO	P A1 A2 G	001 010 100 000	85	O O O I/O	VDDEH6 Slow	— / Up	— / Up	88
CAN_B_RX DSPI_C_PCS[4] SCI_C_RX GPIO[86]	FlexCAN B RX DSPI C peripheral chip select eSCI C RX GPIO	P A1 A2 G	001 010 100 000	86	I O I I/O	VDDEH6 Slow	— / Up	— / Up	89
CAN_C_TX DSPI_D_PCS[3] GPIO[87]	FlexCAN C TX DSPI D peripheral chip select GPIO	P A1 G	01 10 00	87	O O I/O	VDDEH6 Medium	— / Up	— / Up	101
CAN_C_RX DSPI_D_PCS[4] GPIO[88]	FlexCAN C RX DSPI D peripheral chip select GPIO	P A1 G	01 10 00	88	I O I/O	VDDEH6 Slow	— / Up	— / Up	98
eSCI									

Table 3. MPC5644A signal properties (continued)

Name	Function ¹	P A G ²	PCR PA Field ³	PCR ⁴	I/O Type	Voltage ⁵ / Pad Type ⁶	Status ⁷		176
							During Reset	After Reset	
SCI_A_TX EMIOS13 ⁸ GPIO[89]	eSCI A TX eMIOS channel GPIO	P A1 G	01 10 00	89	O O I/O	VDDEH6 Medium	— / Up	— / Up	100
SCI_A_RX EMIOS15 ⁸ GPIO[90]	eSCI A RX eMIOS channel GPIO	P A1 G	01 10 00	90	I O I/O	VDDEH6 Medium	— / Up	— / Up	99
SCI_B_TX DSPI_D_PCS[1] GPIO[91]	eSCI B TX DSPI D peripheral chip select GPIO	P A1 G	01 10 00	91	O O I/O	VDDEH6 Medium	— / Up	— / Up	87
SCI_B_RX DSPI_D_PCS[5] GPIO[92]	eSCI B RX DSPI D peripheral chip select GPIO	P A1 G	01 10 00	92	I O I/O	VDDEH6 Medium	— / Up	— / Up	84
SCI_C_TX GPIO[244]	eSCI C TX GPIO	P G	01 00	244	O I/O	VDDEH6 Medium	— / Up	— / Up	—
SCI_C_RX GPIO[245]	eSCI C RX GPIO	P G	01 00	245	I I/O	VDDEH6 Medium	— / Up	— / Up	—
DSPI									
DSPI_A_SCK ¹⁷ DSPI_C_PCS[1] GPIO[93]	— DSPI C peripheral chip select GPIO	— A1 G	— 10 00	93	— O I/O	VDDEH7 Medium	— / Up	— / Up	—
DSPI_A_SIN ¹⁷ DSPI_C_PCS[2] GPIO[94]	— DSPI C peripheral chip select GPIO	— A1 G	— 10 00	94	— O I/O	VDDEH7 Medium	— / Up	— / Up	—
DSPI_A_SOUT ¹⁷ DSPI_C_PCS[5] GPIO[95]	— DSPI C peripheral chip select GPIO	— A1 G	— 10 00	95	— O I/O	VDDEH7 Medium	— / Up	— / Up	—
DSPI_A_PCS[0] ¹⁷ DSPI_D_PCS[2] GPIO[96]	— DSPI D peripheral chip select GPIO	— A1 G	— 10 00	96	— O I/O	VDDEH7 Medium	— / Up	— / Up	—
DSPI_A_PCS[1] ¹⁷ DSPI_B_PCS[2] GPIO[97]	— DSPI B peripheral chip select GPIO	— A1 G	— 10 00	97	— O I/O	VDDEH7 Medium	— / Up	— / Up	—
CS[2] DSPI_D_SCK GPIO[98]	— SPI clock pin for DSPI module GPIO	— A1 G	— 10 00	98	— I/O I/O	VDDEH7 Medium	— / Up	— / Up	141

Table 3. MPC5644A signal properties (continued)

Name	Function ¹	P A G ²	PCR PA Field ³	PCR ⁴	I/O Type	Voltage ⁵ / Pad Type ⁶	Status ⁷		176
							During Reset	After Reset	
CS[3] DSPI_D_SIN GPIO[99]	— DSPI D data input GPIO	— A1 G	— 10 00	99	— I I/O	VDDEH7 Medium	— / Up	— / Up	142
DSPI_A_PCS[4] ¹⁷ DSPI_D_SOUT GPIO[100]	— DSPI D data output GPIO	— A1 G	— 10 00	100	O I/O	VDDEH7 Medium	— / Up	— / Up	—
DSPI_A_PCS[5] ¹⁷ DSPI_B_PCS[3] GPIO[101]	— DSPI B peripheral chip select GPIO	— A1 G	— 10 00	101	O I/O	VDDEH7 Medium	— / Up	— / Up	—
DSPI_B_SCK DSPI_C_PCS[1] GPIO[102]	SPI clock pin for DSPI module DSPI C peripheral chip select GPIO	P A1 G	01 10 00	102	I/O O I/O	VDDEH6 Medium	— / Up	— / Up	106
DSPI_B_SIN DSPI_C_PCS[2] GPIO[103]	DSPI B data input DSPI C peripheral chip select GPIO	P A1 G	01 10 00	103	I O I/O	VDDEH6 Medium	— / Up	— / Up	112
DSPI_B_SOUT DSPI_C_PCS[5] GPIO[104]	DSPI B data output DSPI C peripheral chip select GPIO	P A1 G	01 10 00	104	O O I/O	VDDEH6 Medium	— / Up	— / Up	113
DSPI_B_PCS[0] DSPI_D_PCS[2] GPIO[105]	DSPI B peripheral chip select DSPI D peripheral chip select GPIO	P A1 G	01 10 00	105	I/O O I/O	VDDEH6 Medium	— / Up	— / Up	111
DSPI_B_PCS[1] DSPI_D_PCS[0] GPIO[106]	DSPI B peripheral chip select DSPI D peripheral chip select GPIO	P A1 G	01 10 00	106	O I/O I/O	VDDEH6 Medium	— / Up	— / Up	109
DSPI_B_PCS[2] DSPI_C_SOUT GPIO[107]	DSPI B peripheral chip select DSPI C data output GPIO	P A1 G	01 10 00	107	O O I/O	VDDEH6 Medium	— / Up	— / Up	107
DSPI_B_PCS[3] DSPI_C_SIN GPIO[108]	DSPI B peripheral chip select DSPI C data input GPIO	P A1 G	01 10 00	108	O I I/O	VDDEH6 Medium	— / Up	— / Up	114
DSPI_B_PCS[4] DSPI_C_SCK GPIO[109]	DSPI B peripheral chip select SPI clock pin for DSPI module GPIO	P A1 G	01 10 00	109	O I/O I/O	VDDEH6 Medium	— / Up	— / Up	105
DSPI_B_PCS[5] DSPI_C_PCS[0] GPIO[110]	DSPI B peripheral chip select DSPI C peripheral chip select GPIO	P A1 G	01 10 00	110	O I/O I/O	VDDEH6 Medium	— / Up	— / Up	104

Table 3. MPC5644A signal properties (continued)

Name	Function ¹	P A G ²	PCR PA Field ³	PCR ⁴	I/O Type	Voltage ⁵ / Pad Type ⁶	Status ⁷		176
							During Reset	After Reset	
eQADC									
AN0 ¹⁸ DAN0+	Single Ended Analog Input Positive Terminal Diff. Input	P	—	—	I I	VDDA Analog	I / —	AN[0] / —	172
AN1 ¹⁸ DAN0-	Single Ended Analog Input Negative Terminal Diff. Input	P	—	—	I I	VDDA Analog	I / —	AN[1] / —	171
AN2 ¹⁸ DAN1+	Single Ended Analog Input Positive Terminal Diff. Input	P	—	—	I I	VDDA Analog	I / —	AN[2] / —	170
AN3 ¹⁸ DAN1-	Single Ended Analog Input Negative Terminal Diff. Input	P	—	—	I I	VDDA Analog	I / —	AN[3] / —	169
AN4 ¹⁸ DAN2+	Single Ended Analog Input Positive Terminal Diff. Input	P	—	—	I I	VDDA Analog	I / —	AN[4] / —	168
AN5 ¹⁸ DAN2-	Single Ended Analog Input Negative Terminal Diff. Input	P	—	—	I I	VDDA Analog	I / —	AN[5] / —	167
AN6 ¹⁸ DAN3+	Single Ended Analog Input Positive Terminal Diff. Input	P	—	—	I I	VDDA Analog	I / —	AN[6] / —	166
AN7 ¹⁸ DAN3-	Single Ended Analog Input Negative Terminal Diff. Input	P	—	—	I I	VDDA Analog	I / —	AN[7] / —	165
AN8 ANW	Single-ended Analog Input Multiplexed Analog Input	P	01	—	I I	VDDA Analog	I / —	AN[8] / —	9
AN9 ANX	Single-ended Analog Input External Multiplexed Analog Input	P	01	—	I I	VDDA Analog	I / —	AN[9] / —	5
AN10 ANY	Single-ended Analog Input Multiplexed Analog Input	P	01	—	I I	VDDA Analog	I / —	AN[10] / —	—
AN11 ANZ	Single-ended Analog Input Multiplexed Analog Input	P	01	—	I I	VDDA Analog	I / —	AN[11] / —	4
AN12 - SDS MA0 ETPUA19_O ⁸ SDS	Single-ended Analog Input MUX Address 0 eTPU A channel (output only) eQADC Serial Data Select	P A1 A2 G	001 010 100 000	215	I O O I/O	VDDEH7 ¹⁹ Medium	I / —	AN[12] / —	148
AN13 - SDO MA1 ETPUA21_O ⁸ SDO	Single-ended Analog Input MUX Address 1 eTPU A channel (output only) eQADC Serial Data Out	P A1 A2 G	001 010 100 000	216	I O O O	VDDEH7 ¹⁹ Medium	I / —	AN[13] / —	147

Table 3. MPC5644A signal properties (continued)

Name	Function ¹	P A G ²	PCR PA Field ³	PCR ⁴	I/O Type	Voltage ⁵ / Pad Type ⁶	Status ⁷		176
							During Reset	After Reset	
AN14 - SDI MA2 ETPUA27_O ⁸ SDI	Single-ended Analog Input MUX Address 2 eTPU A channel (output only) eQADC Serial Data In	P A1 A2 G	001 010 100 000	217	I O O I	VDDEH7 ¹⁹ Medium	I / —	AN[14] / —	146
AN15 - FCK FCK ETPUA29_O ⁸	Single-ended Analog Input eQADC Free Running Clock eTPU A channel (output only)	P A1 A2	001 010 100	218	I O O	VDDEH7 ¹⁹ Medium	I / —	AN[15] / —	145
AN16	Single-ended Analog Input	P	—	—	I	VDDA Analog	I / —	AN[16] / —	3
AN17	Single-ended Analog Input	P	—	—	I	VDDA Analog	I / —	AN[17] / —	2
AN18	Single-ended Analog Input	P	—	—	I	VDDA Analog	I / —	AN[18] / —	1
AN19	Single-ended Analog Input	P	—	—	I	VDDA Analog	I / —	AN[19] / —	—
AN20	Single-ended Analog Input	P	—	—	I	VDDA Analog	I / —	AN[20] / —	—
AN21	Single-ended Analog Input	P	—	—	I	VDDA Analog	I / —	AN[21] / —	173
AN22	Single-ended Analog Input	P	—	—	I	VDDA Analog	I / —	AN[22] / —	161
AN23	Single-ended Analog Input	P	—	—	I	VDDA Analog	I / —	AN[23] / —	160
AN24	Single-ended Analog Input	P	—	—	I	VDDA Analog	I / —	AN[24] / —	159
AN25	Single-ended Analog Input	P	—	—	I	VDDA Analog	I / —	AN[25] / —	158
AN26	Single-ended Analog Input	P	—	—	I	VDDA Analog	I / —	AN[26] / —	—
AN27	Single-ended Analog Input	P	—	—	I	VDDA Analog	I / —	AN[27] / —	157
AN28	Single-ended Analog Input	P	—	—	I	VDDA Analog	I / —	AN[28] / —	156

Table 3. MPC5644A signal properties (continued)

Name	Function ¹	P A G ²	PCR PA Field ³	PCR ⁴	I/O Type	Voltage ⁵ / Pad Type ⁶	Status ⁷		176
							During Reset	After Reset	
AN29	Single-ended Analog Input	P	—	—	I	VDDA Analog	I / —	AN[29] / —	—
AN30	Single-ended Analog Input	P	—	—	I	VDDA Analog	I / —	AN[30] / —	155
AN31	Single-ended Analog Input	P	—	—	I	VDDA Analog	I / —	AN[31] / —	154
AN32	Single-ended Analog Input	P	—	—	I	VDDA Analog	I / —	AN[32] / —	153
AN33	Single-ended Analog Input	P	—	—	I	VDDA Analog	I / —	AN[33] / —	152
AN34	Single-ended Analog Input	P	—	—	I	VDDA Analog	I / —	AN[34] / —	151
AN35	Single-ended Analog Input	P	—	—	I	VDDA Analog	I / —	AN[35] / —	150
AN36	Single-ended Analog Input	P	—	—	I	VDDA Analog	I / —	AN[36] / —	174
AN37	Single-ended Analog Input	P	—	—	I	VDDA Analog	I / —	AN[37] / —	175
AN38	Single-ended Analog Input	P	—	—	I	VDDA Analog	I / —	AN[38] / —	—
AN39	Single-ended Analog Input	P	—	—	I	VDDA Analog	I / —	AN[39] / —	8
VRH	Voltage Reference High	P	—	—	I	VDDA —	I / —	VRH	163
VRL	Voltage Reference Low	P	—	—	I	VDDA —	I / —	VRL	162
REFBYBC	Reference Bypass Capacitor Input	P	—	—	I	VDDA Analog	I / —	REFBYPC	164
eTPU2									
TCRCLKA IRQ[7] GPIO[113]	eTPU A TCR clock External interrupt request GPIO	P A1 G	01 10 00	113	I I I/O	VDDEH4 Slow	— / Up	— / Up	—

Table 3. MPC5644A signal properties (continued)

Name	Function ¹	P A G ²	PCR PA Field ³	PCR ⁴	I/O Type	Voltage ⁵ / Pad Type ⁶	Status ⁷		176
							During Reset	After Reset	
ETPUA0 ETPUA12_O ⁸ ETPUA19_O ⁸ GPIO[114]	eTPU A channel eTPU A channel (output only) eTPU A channel (output only) GPIO	P A1 A2 G	001 010 100 000	114	I/O O O I/O	VDDEH4 Slow	— / WKPCFG	— / WKPCFG	61
ETPUA1 ETPUA13_O ⁸ GPIO[115]	eTPU A channel eTPU A channel (output only) GPIO	P A1 G	01 10 00	115	I/O O I/O	VDDEH4 Slow	— / WKPCFG	— / WKPCFG	60
ETPUA2 ETPUA14_O ⁸ GPIO[116]	eTPU A channel eTPU A channel (output only) GPIO	P A1 G	01 10 00	116	I/O O I/O	VDDEH4 Slow	— / WKPCFG	— / WKPCFG	59
ETPUA3 ETPUA15_O ⁸ GPIO[117]	eTPU A channel eTPU A channel (output only) GPIO	P A1 G	01 10 00	117	I/O O I/O	VDDEH4 Slow	— / WKPCFG	GPIO / WKPCFG	58
ETPUA4 ETPUA16_O ⁸ FR_B_TX GPIO[118]	eTPU A channel eTPU A channel (output only) Flexray TX data channel B GPIO	P A1 A3 G	0001 0010 1000 0000	118	I/O O O I/O	VDDEH4 Slow	— / WKPCFG	— / WKPCFG	56
ETPUA5 ETPUA17_O ⁸ DSPI_B_SCK_LV DS- FR_B_TX_EN GPIO[119]	eTPU A channel eTPU A channel (output only) LVDS negative DSPI clock Flexray TX data enable for ch. B GPIO	P A1 A2 A3 G	0001 0010 0100 1000 0000	119	I/O O O O I/O	VDDEH4 Slow + LVDS	— / WKPCFG	— / WKPCFG	54
ETPUA6 ETPUA18_O ⁸ DSPI_B_SCK_LV DS+ FR_B_RX GPIO[120]	eTPU A channel eTPU A channel (output only) LVDS positive DSPI clock Flexray RX data channel B GPIO	P A1 A2 A3 G	0001 0010 0100 1000 0000	120	I/O O O I I/O	VDDEH4 Medium + LVDS	— / WKPCFG	— / WKPCFG	53
ETPUA7 ETPUA19_O ⁸ DSPI_B_SOUT_L VDS- ETPUA6_O ⁸ GPIO[121]	eTPU A channel eTPU A channel (output only) LVDS negative DSPI data out eTPU A channel (output only) GPIO	P A1 A2 A3 G	0001 0010 0100 1000 0000	121	I/O O O O I/O	VDDEH4 Slow + LVDS	— / WKPCFG	— / WKPCFG	52

Table 3. MPC5644A signal properties (continued)

Name	Function ¹	P A G ²	PCR PA Field ³	PCR ⁴	I/O Type	Voltage ⁵ / Pad Type ⁶	Status ⁷		176
							During Reset	After Reset	
ETPUA8 ETPUA20_O ⁸ DSPI_B_SOUT_L VDS+ GPIO[122]	eTPU A channel eTPU A channel (output only) LVDS positive DSPI data out GPIO	P A1 A2 G	001 010 100 000	122	I/O O O I/O	VDDEH4 Slow + LVDS	—/ WKPCFG	—/ WKPCFG	51
ETPUA9 ETPUA21_O ⁸ RCH1_B GPIO[123]	eTPU A channel eTPU A channel (output only) Reaction channel 1B GPIO	P A1 A2 G	001 010 100 000	123	I/O O O I/O	VDDEH4 Slow	—/ WKPCFG	—/ WKPCFG	50
ETPUA10 ETPUA22_O ⁸ RCH1_C GPIO[124]	eTPU A channel eTPU A channel (output only) Reaction channel 1C GPIO	P A1 A2 G	001 010 100 000	124	I/O O O I/O	VDDEH1 Slow	—/ WKPCFG	—/ WKPCFG	49
ETPUA11 ETPUA23_O ⁸ RCH4_B GPIO[125]	eTPU A channel eTPU A channel (output only) Reaction channel 4B GPIO	P A1 A2 G	001 010 100 000	125	I/O O O I/O	VDDEH1 Slow	—/ WKPCFG	—/ WKPCFG	48
ETPUA12 DSPI_B_PCS[1] RCH4_C GPIO[126]	eTPU A channel DSPI B peripheral chip select Reaction channel 4C GPIO	P A1 A2 G	001 010 100 000	126	I/O O O I/O	VDDEH1 Medium	—/ WKPCFG	—/ WKPCFG	47
ETPUA13 DSPI_B_PCS[3] GPIO[127]	eTPU A channel DSPI B peripheral chip select GPIO	P A1 G	01 10 00	127	I/O O I/O	VDDEH1 Medium	—/ WKPCFG	—/ WKPCFG	46
ETPUA14 DSPI_B_PCS[4] ETPUA9_O ⁸ RCH0_A GPIO[128]	eTPU A channel DSPI B peripheral chip select eTPU A channel (output only) Reaction channel 0A GPIO	P A1 A2 A3 G	0001 0010 0100 1000 0000	128	I/O O O O I/O	VDDEH1 Medium	—/ WKPCFG	—/ WKPCFG	42
ETPUA15 DSPI_B_PCS[5] RCH1_A GPIO[129]	eTPU A channel DSPI B peripheral chip select Reaction channel 1A GPIO	P A1 A2 G	001 010 100 000	129	I/O O O I/O	VDDEH1 Medium	—/ WKPCFG	—/ WKPCFG	40
ETPUA16 DSPI_D_PCS[1] RCH2_A GPIO[130]	eTPU A channel DSPI D peripheral chip select Reaction channel 2A GPIO	P A1 A2 G	001 010 100 000	130	I/O O O I/O	VDDEH1 Slow	—/ WKPCFG	—/ WKPCFG	39

Table 3. MPC5644A signal properties (continued)

Name	Function ¹	P A G ²	PCR PA Field ³	PCR ⁴	I/O Type	Voltage ⁵ / Pad Type ⁶	Status ⁷		176
							During Reset	After Reset	
ETPUA17 DSPI_D_PCS[2] RCH3_A GPIO[131]	eTPU A channel DSPI D peripheral chip select Reaction channel 3A GPIO	P A1 A2 G	001 010 100 000	131	I/O O O I/O	VDDEH1 Slow	—/ WKPCFG	—/ WKPCFG	38
ETPUA18 DSPI_D_PCS[3] RCH4_A GPIO[132]	eTPU A channel DSPI D peripheral chip select Reaction channel 4A GPIO	P A1 A2 G	001 010 100 000	132	I/O O O I/O	VDDEH1 Slow	—/ WKPCFG	—/ WKPCFG	37
ETPUA19 DSPI_D_PCS[4] RCH5_A GPIO[133]	eTPU A channel DSPI D peripheral chip select Reaction channel 5A GPIO	P A1 A2 G	001 010 100 000	133	I/O O O I/O	VDDEH1 Slow	—/ WKPCFG	—/ WKPCFG	36
ETPUA20 IRQ[8] RCH0_B FR_A_TX GPIO[134]	eTPU A channel External interrupt request Reaction channel 0B Flexray TX data channel A GPIO	P A1 A2 A3 G	0001 0010 0100 1000 0000	134	I/O I O O I/O	VDDEH1 Slow	—/ WKPCFG	—/ WKPCFG	35
ETPUA21 IRQ[9] RCH0_C FR_A_RX GPIO[135]	eTPU A channel External interrupt request Reaction channel 0C Flexray RX channel A GPIO	P A1 A2 A3 G	0001 0010 0100 1000 0000	135	I/O I O I I/O	VDDEH1 Slow	—/ WKPCFG	—/ WKPCFG	34
ETPUA22 IRQ[10] ETPUA17_O ⁸ GPIO[136]	eTPU A channel External interrupt request eTPU A channel (output only) GPIO	P A1 A2 G	001 010 100 000	136	I/O I O I/O	VDDEH1 Slow	—/ WKPCFG	—/ WKPCFG	32
ETPUA23 IRQ[11] ETPUA21_O ⁸ FR_A_TX_EN GPIO[137]	eTPU A channel External interrupt request eTPU A channel (output only) Flexray ch. A TX enable GPIO	P A1 A2 A3 G	0001 0010 0100 1000 0000	137	I/O I O O I/O	VDDEH1 Slow	—/ WKPCFG	—/ WKPCFG	30
ETPUA24 IRQ[12] DSPI_C_SCK_LV DS- GPIO[138]	eTPU A channel External interrupt request LVDS negative DSPI clock GPIO	P A1 A2 G	001 010 100 000	138	I/O I O I/O	VDDEH1 Slow + LVDS	—/ WKPCFG	—/ WKPCFG	28

Table 3. MPC5644A signal properties (continued)

Name	Function ¹	P A G ²	PCR PA Field ³	PCR ⁴	I/O Type	Voltage ⁵ / Pad Type ⁶	Status ⁷		176
							During Reset	After Reset	
ETPUA25 IRQ[13] DSPI_C_SCK_LV DS+ GPIO[139]	eTPU A channel External interrupt request LVDS positive DSPI clock GPIO	P A1 A2 G	001 010 100 000	139	I/O I O I/O	VDDEH1 Medium + LVDS	— / WKPCFG	— / WKPCFG	27
ETPUA26 IRQ[14] DSPI_C_SOUT_L VDS- GPIO[140]	eTPU A channel External interrupt request LVDS negative DSPI data out GPIO	P A1 A2 G	001 010 100 000	140	I/O I O I/O	VDDEH1 Slow + LVDS	— / WKPCFG	— / WKPCFG	26
ETPUA27 IRQ[15] DSPI_C_SOUT_L VDS+ DSPI_B_SOUT GPIO[141]	eTPU A channel External interrupt request LVDS positive DSPI data out DSPI data out GPIO	P A1 A2 A3 G	0001 0010 0100 1000 0000	141	I/O I O O I/O	VDDEH1 Slow + LVDS	— / WKPCFG	— / WKPCFG	25
ETPUA28 DSPI_C_PCS[1] RCH5_B GPIO[142]	eTPU A channel DSPI C peripheral chip select Reaction channel 5B GPIO	P A1 A2 G	001 010 100 000	142	I/O O O I/O	VDDEH1 Medium	— / WKPCFG	— / WKPCFG	24
ETPUA29 DSPI_C_PCS[2] RCH5_C GPIO[143]	eTPU A channel DSPI C peripheral chip select Reaction channel 5C GPIO	P A1 A2 G	001 010 100 000	143	I/O O O I/O	VDDEH1 Medium	— / WKPCFG	— / WKPCFG	23
ETPUA30 DSPI_C_PCS[3] ETPUA11_O ⁸ GPIO[144]	eTPU A channel DSPI C peripheral chip select eTPU A channel (output only) GPIO	P A1 A2 G	001 010 100 000	144	I/O O O I/O	VDDEH1 Medium	— / WKPCFG	— / WKPCFG	22
ETPUA31 DSPI_C_PCS[4] ETPUA13_O ⁸ GPIO[145]	eTPU A channel DSPI C peripheral chip select eTPU A channel (output only) GPIO	P A1 A2 G	001 010 100 000	145	I/O O O I/O	VDDEH1 Medium	— / WKPCFG	— / WKPCFG	21
eMIOS									
EMIOS0 ETPUA0_O ⁸ ETPUA25_O ⁸ GPIO[179]	eMIOS channel eTPU A channel (output only) eTPU A channel (output only) GPIO	P A1 A2 G	001 010 100 000	179	I/O O O I/O	VDDEH4 Slow	— / Up	— / Up	63

Table 3. MPC5644A signal properties (continued)

Name	Function ¹	P A G ²	PCR PA Field ³	PCR ⁴	I/O Type	Voltage ⁵ / Pad Type ⁶	Status ⁷		176
							During Reset	After Reset	
EMIOS1 ETPUA1_O ⁸ GPIO[180]	eMIOS channel eTPU A channel (output only) GPIO	P A1 G	01 10 00	180	I/O O I/O	VDDEH4 Slow	— / Up	— / Up	64
EMIOS2 ETPUA2_O ⁸ RCH2_B GPIO[181]	eMIOS channel eTPU A channel (output only) Reaction channel 2B GPIO	P A1 A2 G	001 010 100 000	181	I/O O O I/O	VDDEH4 Slow	— / Up	— / Up	65
EMIOS3 ETPUA3_O ⁸ GPIO[182]	eMIOS channel eTPU A channel (output only) GPIO	P A1 G	01 10 00	182	I/O O I/O	VDDEH4 Slow	— / WKPCFG	— / WKPCFG	66
EMIOS4 ETPUA4_O ⁸ RCH2_C GPIO[183]	eMIOS channel eTPU A channel (output only) Reaction channel 2C GPIO	P A1 A2 G	001 010 100 000	183	I/O O O I/O	VDDEH4 Slow	— / WKPCFG	— / WKPCFG	67
EMIOS5 ETPUA5_O ⁸ GPIO[184]	eMIOS channel eTPU A channel (output only) GPIO	P A1 G	01 10 00	184	I/O O I/O	VDDEH4 Slow	— / WKPCFG	— / WKPCFG	—
EMIOS6 ETPUA6_O ⁸ GPIO[185]	eMIOS channel eTPU A channel (output only) GPIO	P A1 G	01 10 00	185	I/O O I/O	VDDEH4 Slow	— / Down	— / Down	68
EMIOS7 ETPUA7_O ⁸ GPIO[186]	eMIOS channel eTPU A channel (output only) GPIO	P A1 G	01 10 00	186	I/O O I/O	VDDEH4 Slow	— / Down	— / Down	69
EMIOS8 ETPUA8_O ⁸ SCI_B_TX GPIO[187]	eMIOS channel eTPU A channel (output only) eSCI B TX GPIO	P A1 A2 G	001 010 100 000	187	I/O O O I/O	VDDEH4 Slow	— / Up	— / Up	70
EMIOS9 ETPUA9_O ⁸ SCI_B_RX GPIO[188]	eMIOS channel eTPU A channel (output only) eSCI B RX GPIO	P A1 A2 G	001 010 100 000	188	I/O O I I/O	VDDEH4 Slow	— / Up	— / Up	71
EMIOS10 DSPI_D_PCS[3] RCH3_B GPIO[189]	eMIOS channel DSPI D peripheral chip select Reaction channel 3B GPIO	P A1 A2 G	001 010 100 000	189	I/O O O I/O	VDDEH4 Medium	— / WKPCFG	— / WKPCFG	73

Table 3. MPC5644A signal properties (continued)

Name	Function ¹	P A G ²	PCR PA Field ³	PCR ⁴	I/O Type	Voltage ⁵ / Pad Type ⁶	Status ⁷		176
							During Reset	After Reset	
EMIOS11 DSPI_D_PCS[4] RCH3_C GPIO[190]	eMIOS channel DSPI D peripheral chip select Reaction channel 3C GPIO	P A1 A2 G	001 010 100 000	190	I/O O O I/O	VDDEH4 Medium	— / WKPCFG	— / WKPCFG	75
EMIOS12 DSPI_C_SOUT ETPUA27_O ⁸ GPIO[191]	eMIOS channel DSPI C data output eTPU A channel (output only) GPIO	P A1 A2 G	001 010 100 000	191	I/O O O I/O	VDDEH4 Medium	— / WKPCFG	— / WKPCFG	76
EMIOS13 DSPI_D_SOUT GPIO[192]	eMIOS channel DSPI D data output GPIO	P A1 G	01 10 00	192	I/O O I/O	VDDEH4 Medium	— / WKPCFG	— / WKPCFG	77
EMIOS14 IRQ[0] ETPUA29_O ⁸ GPIO[193]	eMIOS channel External interrupt request eTPU A channel (output only) GPIO	P A1 A2 G	001 010 100 000	193	I/O I O I/O	VDDEH4 Slow	— / Down	— / Down	78
EMIOS15 IRQ[1] GPIO[194]	eMIOS channel External interrupt request GPIO	P A1 G	01 10 00	194	I/O I I/O	VDDEH4 Slow	— / Down	— / Down	79
EMIOS16 GPIO[195]	eMIOS channel GPIO	P G	01 00	195	I/O I/O	VDDEH4 Slow	— / Up	— / Up	—
EMIOS17 GPIO[196]	eMIOS channel GPIO	P G	01 00	196	I/O I/O	VDDEH4 Slow	— / Up	— / Up	—
EMIOS18 GPIO[197]	eMIOS channel GPIO	P G	01 00	197	I/O I/O	VDDEH4 Slow	— / Up	— / Up	—
EMIOS19 GPIO[198]	eMIOS channel GPIO	P G	01 00	198	I/O I/O	VDDEH4 Slow	— / WKPCFG	— / WKPCFG	—
EMIOS20 GPIO[199]	eMIOS channel GPIO	P G	01 00	199	I/O I/O	VDDEH4 Slow	— / WKPCFG	— / WKPCFG	—
EMIOS21 GPIO[200]	eMIOS channel GPIO	P G	01 00	200	I/O I/O	VDDEH4 Slow	— / WKPCFG	— / WKPCFG	—
EMIOS22 GPIO[201]	eMIOS channel GPIO	P G	01 00	201	I/O I/O	VDDEH4 Slow	— / Down	— / Down	—
EMIOS23 GPIO[202]	eMIOS channel GPIO	P G	01 00	202	I/O I/O	VDDEH4 Slow	— / Down	— / Down	80
Clock Synthesizer									

Table 3. MPC5644A signal properties (continued)

Name	Function ¹	P A G ²	PCR PA Field ³	PCR ⁴	I/O Type	Voltage ⁵ / Pad Type ⁶	Status ⁷		176
							During Reset	After Reset	
XTAL	Crystal oscillator output	P	01	—	O	VDDEH6 Analog	—	—	93
EXTAL EXTCLK	Crystal oscillator input External clock input	P A	01 10	—	I	VDDEH6 Analog	—	—	92
CLKOUT	System clock output	P	01	229	O	VDDE5 Fast	—	CLKOUT	—
ENGCLK	Engineering clock output	P	01	214	O	VDDE5 Fast	—	ENGCLK	—
Power / Ground									
VDDREG	Voltage Regulator Supply	—		—	I	5 V	I / —	VDDREG	10
VRCCTL	Voltage Regulator Control Output	—		—	O	—	O / —	VRCCTL	11
VRC33 ²⁰	Internal regulator output	—		—	O	3.3 V	I/O / —	VRC33	13
	Input for external 3.3 V supply	—		—		3.3 V			
VDDA	eQADC high reference voltage	—		—	I	5 V	I / —	VDDA	6
VSSA	eQADC ground/low reference voltage	—		—	I	—	I / —	VSSA	7
VDDA0 ²¹	eQADC high reference voltage	—		—	I	5 V	I / —	VDDA0	—
VSSA0 ²²	eQADC ground/low reference voltage	—		—	I	—	I / —	VSSA0	—
VDDA1 ²¹	eQADC high reference voltage	—		—	I	5 V	I / —	VDDA1	—
VSSA1 ²²	eQADC ground/low reference voltage	—		—	I	—	I / —	VSSA1	—
VDDPLL	FMPLL Supply Voltage	—		—	I	1.2	I / —	VDDPLL	91
VSTBY	Power Supply for Standby RAM	—		—	I	0.9 V - 6 V	I / —	VSTBY	12
VDD	Core supply for input or decoupling	—		—	I	1.2 V	I / —	VDD	33, 45, 62, 103, 132, 149, 176

Table 3. MPC5644A signal properties (continued)

Name	Function ¹	P A G ²	PCR PA Field ³	PCR ⁴	I/O Type	Voltage ⁵ / Pad Type ⁶	Status ⁷		176
							During Reset	After Reset	
VDDE12	External supply input for calibration bus interfaces	—		—	I	1.8 V - 3.3 V	I / —	VDDE12	—
VDDE2 ²³	External supply input for EBI interfaces	—		—	I	1.8 V - 3.3 V	I / —	VDDE2 ²⁴	—
VDDE5	External supply input for ENGCLK, CLKOUT and EBI signals DATA[0:15]	—		—	I	1.8 V - 3.3 V	I / —	VDDE5	—
VDDE-EH	External supply for EBI interfaces	—		—	I	3.0 V - 5 V	I / —	VDDE-EH	—
VDDEH1A ²⁵	I/O Supply Input	—		—	I	3.3 V - 5.0 V	I / —	VDDEH1A ²⁵	31
VDDEH1B ²⁵	I/O Supply Input	—		—	I	3.3 V - 5.0 V	I / —	VDDEH1B ²⁵	41
VDDEH1AB ²⁵	I/O Supply Input	—		—	I	3.3 V - 5.0 V	I / —	VDDEH1AB ²⁵	—
VDDEH4 ²⁶	I/O Supply Input	—		—	I	3.3 V - 5.0 V	I / —	VDDEH4 ²⁶	—
VDDEH4A ²⁶	I/O Supply Input	—		—	I	3.3 V - 5.0 V	I / —	VDDEH4A ²⁶	55
VDDEH4B ²⁶	I/O Supply Input	—		—	I	3.3 V - 5.0 V	I / —	VDDEH4B ²⁶	74
VDDEH4AB ²⁶	I/O Supply Input	—		—	I	3.3 V - 5.0 V	I / —	VDDEH4AB ²⁶	—
VDDEH6 ²⁷	I/O Supply Input	—		—	I	3.3 V - 5.0 V	I / —	VDDEH6 ²⁷	—
VDDEH6A ²⁷	I/O Supply Input	—		—	I	3.3 V - 5.0 V	I / —	VDDEH6A ²⁷	95
VDDEH6B ²⁷	I/O Supply Input	—		—	I	3.3 V - 5.0 V	I / —	VDDEH6B ²⁷	110
VDDEH6AB ²⁷	I/O Supply Input	—		—	I	3.3 V - 5.0 V	I / —	VDDEH6AB ²⁷	—

Table 3. MPC5644A signal properties (continued)

Name	Function ¹	P A G ²	PCR PA Field ³	PCR ⁴	I/O Type	Voltage ⁵ / Pad Type ⁶	Status ⁷		176
							During Reset	After Reset	
VDDEH7	I/O Supply Input	—		—	I	3.3 V - 5.0 V	I / —	VDDEH7	—
VDDEH7A	I/O Supply Input	—		—	I	3.3 V - 5.0 V	I / —	VDDEH7A	125
VDDEH7B	I/O Supply Input	—		—	I	3.3 V - 5.0 V	I / —	VDDEH7B	138
VSS	Ground	—		—	I	—	I / —	VSS	15, 29, 43, 57, 72, 90, 94, 96, 108, 115, 127, 133, 140

¹ For each pin in the table, each line in the Function column is a separate function of the pin. For all I/O pins the selection of primary function or secondary function or GPIO is done in the SIU except where explicitly noted. See the Signal details table for a description of each function.

² The P/A/G column indicates the position a signal occupies in the muxing order for a pin—Primary, Alternate 1, Alternate 2, Alternate 3. Signals are selected by setting the PA field value in the appropriate PCR register in the SIU module. The PA field values are A1 - 0b0010, A2 - 0b0100, A3 - 0b1000, or G - 0b0000. Depending on the register, the PA field size can vary in length. For fields longer than four bits, remove the appropriate number of leading zeroes from these values.

³ The Pad Configuration Register (PCR) PA field is used by software to select pin function.

⁴ Values in the PCR No. column refer to registers in the System Integration Unit (SIU). The actual register name is "SIU_PCR[register number]". For example, PCR[190] refers to the SIU register named SIU_PCR190.

- ⁵ The VDDE and VDDEH supply inputs are broken into segments. Each segment of slow I/O pins (VDDEH) may have a separate supply in the 1.8 V to 5.0 V range (-10%/+5%). Each segment of fast I/O (VDDE) may have a separate supply in the 1.8 V to 3.3 V range (+10%/+5%).
- ⁶ See [Table 4](#) for details on pad types.
- ⁷ The Status During Reset pin is sampled after the internal POR is negated. Prior to exiting POR, the signal has a high impedance. O - output, I - input, Up - weak pull up enabled, Down - weak pull down enabled, Low - output driven low, High - output driven high. A function in this column denotes that both the input and output buffer are turned off. The signal name to the left or right of the pin is enabled.
- ⁸ Output only.
- ⁹ When used as ETRIG, this pin must be configured as an input. For GPIO it can be configured either as an input or output.
- ¹⁰ Maximum frequency is 50 kHz.
- ¹¹ The SIU_PCR219 register is unusual in that it controls pads for two separate device pins: GPIO[219] and MCKO. See the Microcontroller Reference Manual (SIU chapter) for details.
- ¹² Multivoltage pads are automatically configured in low swing mode when a JTAG or Nexus function is selected, otherwise they are configured in high swing mode.
- ¹³ On 176 LQFP and 208 MAPBGA packages, this pin is tied low internally.
- ¹⁴ Nexus multivoltage pads default to 5 V operation until the Nexus module is enabled.
- ¹⁵ $\overline{\text{EVTO}}$ should be clamped to 3.3 V to prevent possible damage to external tools that only support 3.3 V.
- ¹⁶ Do not connect pin directly to a power supply or ground.
- ¹⁷ This signal name is used to support legacy naming.
- ¹⁸ During and just after POR negates, internal pull resistors can be enabled, resulting in as much as 4 mA of current draw. They are disabled when the system clock propagates through the device.
- ¹⁹ For pins AN12-AN15, if the analog features are used the VDDEH7 input pins should be tied to VDDA because that segment has the highest specification to support analog input function.
- ²⁰ Do not use VRC33 to drive external circuits.
- ²¹ VDDA0 and VDDA1 are shorted together internally in BGA packages. In the QFP package the two pads are double bonded to VDDA.
- ²² VSSA0 and VSSA1 are shorted together internally in BGA packages. In the QFP package the two pads are double bonded to VSSA.
- ²³ VDDE2 and VDDE3 are shorted together in all production packages.
- ²⁴ VDDE2 and VDDE3 are shorted together in all production packages.
- ²⁵ VDDEH1A, VDDEH1B, and VDDEH1AB are shorted together in all production packages. The separation of the signal names is for legacy naming, however they should be considered as the same signal in this document.
- ²⁶ VDDEH4, VDDEH4A, VDDEH4B, and VDDEH4AB are shorted together in all production packages. The separation of the signal names is for legacy naming, however they should be considered as the same signal in this document.
- ²⁷ VDDEH6, VDDEH6A, VDDEH6B, and VDDEH6AB are shorted together in all production packages. The separation of the signal names is for legacy naming, however they should be considered as the same signal in this document.

Table 4. Pad types

Pad Type	Name	I/O Voltage Range
Slow	pad_ssr_hv	3.0V - 5.5 V
Medium	pad_msr_hv	3.0 V - 5.5 V
Fast	pad_fc	3.0 V - 3.6 V
Multiv ^{1,2}	pad_multv_hv	3.0 V - 5.5 V (high swing mode) 3.0 V - 3.6 V (low swing mode)
Analog	pad_ae_hv	0.0 - 5.5 V
LVDS	pad_lo_lv	—

¹ Multivoltage pads are automatically configured in low swing mode when a JTAG or Nexus function is selected, otherwise they are high swing.

² VDDEH7 supply cannot be below 4.5 V when in low-swing mode.

2.5 Signal details

Table 5. Signal details

Signal	Module or Function	Description
CLKOUT	Clock Generation	MPC5644A clock output for the external/calibration bus interface
ENGCLK	Clock Generation	Clock for external ASIC devices
EXTAL	Clock Generation	Input pin for an external crystal oscillator or an external clock source based on the value driven on the PLLREF pin at reset.
PLLREF	Clock Generation Reset/Configuration	<p>PLLREF is used to select whether the oscillator operates in xtal mode or external reference mode from reset. PLLREF=0 selects external reference mode. On the 324BGA package, PLLREF is bonded to the ball used for PLLCFG[0] for compatibility with MPC55xx devices .</p> <p>For the 176-pin QFP and 208-ball BGA packages: 0: External reference clock is selected. 1: XTAL oscillator mode is selected</p> <p>For the 324 ball BGA package: If RSTCFG is 0: 0: External reference clock is selected. 1: XTAL oscillator mode is selected.</p> <p>If RSTCFG is 1, XTAL oscillator mode is selected.</p>
XTAL	Clock Generation	Crystal oscillator input
DSPI_B_SCK_LVDS- DSPI_B_SCK_LVDS+	DSPI	LVDS pair used for DSPI_B TSB mode transmission
DSPI_B_SOUT_LVDS- DSPI_B_SOUT_LVDS+	DSPI	LVDS pair used for DSPI_B TSB mode transmission
DSPI_C_SCK_LVDS- DSPI_C_SCK_LVDS+	DSPI	LVDS pair used for DSPI_C TSB mode transmission

Table 5. Signal details (continued)

Signal	Module or Function	Description
DSPI_C_SOUT_LVDS- DSPI_C_SOUT_LVDS+	DSPI	LVDS pair used for DSPI_C TSB mode transmission
PCS_B[0] PCS_C[0] PCS_D[0]	DSPI_B - DSPI_D	Peripheral chip select when device is in master mode—slave select when used in slave mode
PCS_B[1:5] PCS_C[1:5] PCS_D[1:5]	DSPI_B - DSPI_D	Peripheral chip select when device is in master mode—not used in slave mode
SCK_B SCK_C SCK_D	DSPI_B - DSPI_D	DSPI clock—output when device is in master mode; input when in slave mode
SIN_B SIN_C SIN_D	DSPI_B - DSPI_D	DSPI data in
SOUT_B SOUT_C SOUT_D	DSPI_B - DSPI_D	DSPI data out
ADDR[10:31]	EBI	The ADDR[10:31] signals specify the physical address of the bus transaction. The 26 address lines correspond to bits 3-31 of the EBI's 32-bit internal address bus. ADDR[15:31] can be used as Address and Data signals when configured appropriately for a multiplexed external bus. This allows 32-bit data operations, or 16-bit data operations without using DATA[0:15] signals.
ALE	EBI	The Address Latch Enable (ALE) signal is used to demultiplex the address from the data bus. It is asserted while the least significant 16 bits of the address are present in the multiplexed address/data bus.
$\overline{\text{BDIP}}$	EBI	$\overline{\text{BDIP}}$ is asserted to indicate that the master is requesting another data beat following the current one.
CS[0:3]	EBI	$\overline{\text{CS}}_x$ is asserted by the master to indicate that this transaction is targeted for a particular memory bank on the Primary external bus.
DATA[0:31]	EBI	The DATA[0:31] signals contain the data to be transferred for the current transaction.
$\overline{\text{OE}}$	EBI	$\overline{\text{OE}}$ is used to indicate when an external memory is permitted to drive back read data. External memories must have their data output buffers off when $\overline{\text{OE}}$ is negated. $\overline{\text{OE}}$ is only asserted for chip-select accesses.
$\overline{\text{RD_WR}}$	EBI	$\overline{\text{RD_WR}}$ indicates whether the current transaction is a read access or a write access.

Table 5. Signal details (continued)

Signal	Module or Function	Description
\overline{TA}	EBI	\overline{TA} is asserted to indicate that the slave has received the data (and completed the access) for a write cycle, or returned data for a read cycle. If the transaction is a burst read, \overline{TA} is asserted for each one of the transaction beats. For write transactions, \overline{TA} is only asserted once at access completion, even if more than one write data beat is transferred.
\overline{TS}	EBI	The Transfer Start signal (\overline{TS}) is asserted by the MPC5644A to indicate the start of a transfer.
$\overline{WE}[2:3]$	EBI	Write enables are used to enable program operations to a particular memory. $\overline{WE}[2:3]$ are only asserted for write accesses
$\overline{WE}[0:3]/\overline{BE}[0:3]$	EBI	Write enables are used to enable program operations to a particular memory. These signals can also be used as byte enables for read and write operation by setting the WEBS bit in the appropriate EBI Base Register (EBI_BRn). $\overline{WE}[0:3]$ are only asserted for write accesses. $\overline{BE}[0:3]$ are asserted for both read and write accesses
eMIOS[0:23]	eMIOS	eMIOS I/O channels
AN[0:39]	eQADC	Single-ended analog inputs for analog-to-digital converter
FCK	eQADC	eQADC free running clock for eQADC SSI.
MA[0:2]	eQADC	These three control bits are output to enable the selection for an external Analog Mux for expansion channels.
REFBYPC	eQADC	Bypass capacitor input
SDI	eQADC	Serial data in
SDO	eQADC	Serial data out
SDS	eQADC	Serial data select
VRH	eQADC	Voltage reference high input
VRL	eQADC	Voltage reference low input
SCI_A_RX SCI_B_RX SCI_C_RX	eSCI_A - eSCI_C	eSCI receive
SCI_A_TX SCI_B_TX SCI_C_TX	eSCI_A - eSCI_C	eSCI transmit
ETPU_A[0:31]	eTPU	eTPU I/O channel
RCH0_[A:C] RCH1_[A:C] RCH2_[A:C] RCH3_[A:C] RCH4_[A:C] RCH5_[A:C]	eTPU2 Reaction Module	eTPU2 reaction channels. Used to control external actuators, e.g., solenoid control for direct injection systems and valve control in automatic transmissions
TCRCLKA	eTPU2	Input clock for TCR time base

Table 5. Signal details (continued)

Signal	Module or Function	Description
CAN_A_TX CAN_B_TX CAN_C_TX	FlexCan_A - FlexCAN_C	FlexCAN transmit
CAN_A_RX CAN_B_RX CAN_C_RX	FlexCAN_A - FlexCAN_C	FlexCAN receive
FR_A_RX FR_B_RX	FlexRay	FlexRay receive (Channels A, B)
FR_A_TX_EN FR_B_TX_EN	FlexRay	FlexRay transmit enable (Channels A, B)
FR_A_TX FR_B_TX	FlexRay	Flexray transmit (Channels A, B)
JCOMP	JTAG	Enables the JTAG TAP controller.
TCK	JTAG	Clock input for the on-chip test logic.
TDI	JTAG	Serial test instruction and data input for the on-chip test logic.
TDO	JTAG	Serial test data output for the on-chip test logic.
TMS	JTAG	Controls test mode operations for the on-chip test logic.
$\overline{\text{EVTI}}$	Nexus	$\overline{\text{EVTI}}$ is an input that is read on the negation of $\overline{\text{RESET}}$ to enable or disable the Nexus Debug port. After reset, the $\overline{\text{EVTI}}$ pin is used to initiate program synchronization messages or generate a breakpoint.
$\overline{\text{EVTO}}$	Nexus	Output that provides timing to a development tool for a single watchpoint or breakpoint occurrence.
MCKO	Nexus	MCKO is a free running clock output to the development tools which is used for timing of the MDO and MSEO signals.
MDO[0:11] ¹	Nexus	Trace message output to development tools. This pin also indicates the status of the crystal oscillator clock following a power-on reset, when MDO[0] is driven high until the crystal oscillator clock achieves stability and is then negated.
$\overline{\text{MSEO}}[0:1]$ ¹	Nexus	Output pin—Indicates the start or end of the variable length message on the MDO pins
$\overline{\text{RDY}}$	Nexus	Nexus Ready Output ($\overline{\text{RDY}}$) is an output that indicates to the development tools the data is ready to be read from or written to the Nexus read/write access registers.

Table 5. Signal details (continued)

Signal	Module or Function	Description
BOOTCFG[0:1]	SIU - Configuration	<p>Two BOOTCFG signals are implemented in MPC5644A MCUs.</p> <p>The BAM program uses the BOOTCFG0 bit to determine where to read the reset configuration word, and whether to initiate a FlexCAN or eSCI boot.</p> <p>The BOOTCFG1 pin is sampled during the assertion of the RSTOUT signal, and the value is used to update the RSR and the BAM boot mode</p> <p>See the <i>MPC5644A Microcontroller Reference Manual</i> for more information.</p> <p>The following values are for BOOTCFG[0:1]: 00:Boot from internal flash memory 01:FlexCAN/eSCI boot 10:Boot from external memory using EBI 11:Reserved</p> <p>Note: For the 176-pin QFP and 208-ball BGA packages BOOTCFG[0] is always 0 since the EBI interface is not available.</p>
WKPCFG	SIU - Configuration	<p>The WKPCFG pin is applied at the assertion of the internal reset signal (assertion of RSTOUT), and is sampled 4 clock cycles before the negation of the RSTOUT pin.</p> <p>The value is used to configure whether the eTPU and eMIOS pins are connected to internal weak pull up or weak pull down devices after reset. The value latched on the WKPCFG pin at reset is stored in the Reset Status Register (RSR), and is updated for all reset sources except the Debug Port Reset and Software External Reset.</p> <p>0: Weak pulldown applied to eTPU and eMIOS pins at reset 1: Weak pullup applied to eTPU and eMIOS pins at reset.</p>
ETRIG[2:3]	SIU - eQADC Triggers	External signal eTRIGx triggers eQADC CFIFOx
GPIO[206] ETRIG0 (Input)	SIU - eQADC Triggers	External signal eTRIGx triggers eQADC CFIFOx
GPIO[207] ETRIG1 (Input)	SIU - eQADC Triggers	External signal eTRIGx triggers eQADC CFIFOx
IRQ[0:5] IRQ[7:15]	SIU - External Interrupts	<p>The IRQ[0:15] pins connect to the SIU IRQ inputs. IMUX Select Register 1 is used to select the IRQ[0:15] pins as inputs to the IRQs.</p> <p>See the <i>MPC5644A Microcontroller Reference Manual</i> for more information.</p>
NMI	SIU - External Interrupts	Non-Maskable Interrupt

Table 5. Signal details (continued)

Signal	Module or Function	Description
GPIO[0:3] GPIO[8:43] GPIO[62:65] GPIO[68:70] GPIO[75:145] GPIO[179:204] GPIO[208:213] GPIO[219] GPIO[244:245]	SIU - GPIO	Configurable general purpose I/O pins. Each GPIO input and output is separately controlled by an 8-bit input (GPD1) or output (GPDO) register. Additionally, each GPIO pins is configured using a dedicated SIU_PCR register. The GPIO pins are generally multiplexed with other I/O pin functions. See The <i>MPC5644A Microcontroller Reference Manual</i> for more information. •
$\overline{\text{RESET}}$	SIU - Reset	The $\overline{\text{RESET}}$ pin is an active low input. The $\overline{\text{RESET}}$ pin is asserted by an external device during a power-on or external reset. The internal reset signal asserts only if the $\overline{\text{RESET}}$ pin asserts for 10 clock cycles. Assertion of the $\overline{\text{RESET}}$ pin while the device is in reset causes the reset cycle to start over. The $\overline{\text{RESET}}$ pin has a glitch detector which detects spikes greater than two clock cycles in duration that fall below the switch point of the input buffer logic of the VDDEH input pins. The switch point lies between the maximum VIL and minimum VIH specifications for the VDDEH input pins.
RSTCFG	SIU - Reset	Used to enable or disable the PLLREF and the BOOTCFG[0:1] configuration signals. 0: Get configuration information from BOOTCFG[0:1] and PLLREF 1: Use default configuration of booting from internal flash with crystal clock source Note: For the 176-pin QFP and 208-ball BGA packages RSTCFG is always 0, so PLLREF and BOOTCFG signals are used.
$\overline{\text{RSTOUT}}$	SIU - Reset	The $\overline{\text{RSTOUT}}$ pin is an active low output that uses a push/pull configuration. The $\overline{\text{RSTOUT}}$ pin is driven to the low state by the MCU for all internal and external reset sources. There is a delay between initiation of the reset and the assertion of the $\overline{\text{RSTOUT}}$ pin.

¹ Do not connect pin directly to a power supply or ground.

Table 6. Power/ground segmentation

Power Segment	Voltage	I/O Pins Powered by Segment
VDDE2	1.8 V - 3.3 V	CS0, CS1, CS2, CS3, RD_WR, BDIP, WE0, WE1, OE, TS, TA
VDDE3	1.8 V - 3.3 V	ADDR12, ADDR13, ADDR14, ADDR15
VDDE5	1.8 V - 3.3 V	DATA0, DATA1, DATA2, DATA3, DATA4, DATA5, DATA6, DATA7, DATA8, DATA9, DATA10, DATA11, DATA12, DATA13, DATA14, DATA15, CLKOUT, ENGCLK
VDDE12	1.8 V - 3.3 V	CAL_CS0, CAL_CS2, CAL_CS3, CAL_ADDR12, CAL_ADDR13, CAL_ADDR14, CAL_ADDR15, CAL_ADDR16, CAL_ADDR17, CAL_ADDR18, CAL_ADDR19, CAL_ADDR20, CAL_ADDR21, CAL_ADDR22, CAL_ADDR23, CAL_ADDR24, CAL_ADDR25, CAL_ADDR26, CAL_ADDR27, CAL_ADDR28, CAL_ADDR29, CAL_ADDR30, CAL_DATA0, CAL_DATA1, CAL_DATA2, CAL_DATA3, CAL_DATA4, CAL_DATA5, CAL_DATA6, CAL_DATA7, CAL_DATA8, CAL_DATA9, CAL_DATA10, CAL_DATA11, CAL_DATA12, CAL_DATA13, CAL_DATA14, CAL_DATA15, CAL_RD_WR, CAL_WE0, CAL_WE1, CAL_OE, CAL_TS
VDDE-EH	3.0 V - 5 V	ADDR16, ADDR17, ADDR18, ADDR19, ADDR20, ADDR21, ADDR22, ADDR23, ADDR24, ADDR25, ADDR26, ADDR27, ADDR28, ADDR29, ADDR30, ADDR31
VDDEH1	3.3 V - 5.0 V	ETPUA10, ETPUA11, ETPUA12, ETPUA13, ETPUA14, ETPUA15, ETPUA16, ETPUA17, ETPUA18, ETPUA19, ETPUA20, ETPUA21, ETPUA22, ETPUA23, ETPUA24, ETPUA25, ETPUA26, ETPUA27, ETPUA28, ETPUA29, ETPUA30, ETPUA31
VDDEH4	3.3 V - 5.0 V	EMIOS0, EMIOS1, EMIOS2, EMIOS3, EMIOS4, EMIOS5, EMIOS6, EMIOS7, EMIOS8, EMIOS9, EMIOS10, EMIOS11, EMIOS12, EMIOS13, EMIOS14, EMIOS15, EMIOS16, EMIOS17, EMIOS18, EMIOS19, EMIOS20, EMIOS21, EMIOS22, EMIOS23, TCRCLKA, ETPUA0, ETPUA1, ETPUA2, ETPUA3, ETPUA4, ETPUA5, ETPUA6, ETPUA7, ETPUA8, ETPUA9, ETPUA0
VDDEH6	3.3 V - 5.0 V	RESET, RSTOUT, PLLREF, PLLCFG1, RSTCFG, BOOTCFG0, BOOTCFG1, WKPCFG, CAN_A_TX, CAN_A_RX, CAN_B_TX, CAN_B_RX, CAN_C_TX, CAN_C_RX, SCI_A_TX, SCI_A_RX, SCI_B_TX, SCI_C_RX, DSPI_B_SCK, DSPI_B_SIN, DSPI_B_SOUT, DSPI_B_PCS[0], DSPI_B_PCS[1], DSPI_B_PCS[2], DSPI_B_PCS[3], DSPI_B_PCS[4], DSPI_B_PCS[5], SCI_B_RX, SCI_C_TX, EXTAL, XTAL
VDDEH7	3.3 V - 5.0 V	EMIOS14, EMIOS 15, GPIO98, GPIO99, GPIO203, GPIO204, GPIO206, GPIO207, GPIO219, EVTI, EVTO, MDO4, MDO5, MDO6, MDO7, MDO8, MDO9, MDO10, MDO11, MSEO0, MSEO1, RDY, TCK, TDI, TDO, TMS, JCOMP, DSPI_A_SCK, DSPI_A_SIN, DSPI_A_SOUT, DSPI_A_PCS[0], DSPI_A_PCS[1], DSPI_A_PCS[4], DSPI_A_PCS[5], AN12-SDS, AN13-SDO, AN14-SDI, AN15-FCK

Table 6. Power/ground segmentation

Power Segment	Voltage	I/O Pins Powered by Segment
VDDA	5 V	AN0, AN1, AN2, AN3, AN4, AN5, AN6, AN7, AN8, AN9, AN10, AN11, AN16, AN17, AN18, AN19, AN20, AN21, AN22, AN23, AN24, AN25, AN26, AN27, AN28, AN29, AN30, AN31, AN32, AN33, AN34, AN35, AN36, AN37, AN38, AN39, VRH, VRL, REFBYBC
VRC33 ¹	3.3 V	MCKO, MDO0, MDO1, MDO2, MDO3
Other Power Segments		
VDDREG	5 V	—
VRCCTL	—	—
VDDPLL	1.2 V	—
VSTBY	0.95–1.2 V (unregulated mode)	—
	2.0–5.5 V (regulated mode)	—
VSS	—	—

¹ Do not use VRC33 to drive external circuits.

3 Electrical characteristics

This section contains detailed information on power considerations, DC/AC electrical characteristics, and AC timing specifications for the MPC5644A series of MCUs.

The electrical specifications are preliminary and are from previous designs, design simulations, or initial evaluation. These specifications may not be fully tested or guaranteed at this early stage of the product life cycle, however for production silicon these specifications will be met. Finalized specifications will be published after complete characterization and device qualifications have been completed.

In the tables where the device logic provides signals with their respective timing characteristics, the symbol “CC” for Controller Characteristics is included in the Symbol column.

In the tables where the external system must provide signals with their respective timing characteristics to the device, the symbol “SR” for System Requirement is included in the Symbol column.

3.1 Parameter classification

The electrical parameters shown in this supplement are guaranteed by various methods. To give the customer a better understanding, the classifications listed in [Table 7](#) are used and the parameters are tagged accordingly in the tables where appropriate.

Table 7. Parameter classifications

Classification tag	Tag description
P	Those parameters are guaranteed during production testing on each individual device.
C	Those parameters are achieved by the design characterization by measuring a statistically relevant sample size across process variations.
T	Those parameters are achieved by design characterization on a small sample size from typical devices under typical conditions unless otherwise noted. All values shown in the typical column are within this category.
D	Those parameters are derived mainly from simulations.

NOTE

The classification is shown in the column labeled “C” in the parameter tables where appropriate.

3.2 Maximum ratings

Table 8. Absolute maximum ratings¹

Symbol		Parameter	Conditions	Value		Unit
				min	max	
V _{DD}	SR	1.2 V core supply voltage ²		-0.3	1.32	V
V _{FLASH}	SR	Flash core voltage ^{3,4}		-0.3	3.6	V
V _{STBY}	SR	SRAM standby voltage ⁵		-0.3	6	V
V _{DDPLL}	SR	Clock synthesizer voltage		-0.3	1.32	V
V _{RC33}	SR	Voltage regulator control input voltage ⁴		-0.3	3.6	V

Table 8. Absolute maximum ratings¹ (continued)

Symbol		Parameter	Conditions	Value		Unit
				min	max	
V_{DDA}	SR	Analog supply voltage ⁵	Reference to V_{SSA}	-0.3	5.5	V
V_{DDE}	SR	I/O supply voltage ^{4,6}		-0.3	3.6	V
V_{DDEH}	SR	I/O supply voltage ⁵		-0.3	5.5	V
V_{IN}	SR	DC input voltage ⁷	V_{DDEH} powered I/O pads	-1.0 ⁸	$V_{DDEH} + 0.3 V^9$	V
			V_{DDE} powered I/O pads	-1.0 ¹⁰	$V_{DDE} + 0.3 V^{10}$	
			V_{DDA} powered I/O pads	-1.0	5.5	
V_{DDREG}	SR	Voltage regulator supply voltage		-0.3	5.5	V
V_{RH}	SR	Analog reference high voltage	Reference to VRL	-0.3	5.5	V
$V_{SS} - V_{SSA}$	SR	V_{SS} differential voltage		-0.1	0.1	V
$V_{RH} - V_{RL}$	SR	V_{REF} differential voltage		-0.3	5.5	V
$V_{RL} - V_{SSA}$	SR	VRL to V_{SSA} differential voltage		-0.3	0.3	V
$V_{SSPLL} - V_{SS}$	SR	V_{SSPLL} to V_{SS} differential voltage		-0.1	0.1	V
I_{MAXD}	SR	Maximum DC digital input current ¹¹	Per pin, applies to all digital pins	-3	3	mA
I_{MAXA}	SR	Maximum DC analog input current ¹²	Per pin, applies to all analog pins	—	5	mA
T_J	SR	Maximum operating temperature range - die junction temperature		-40.0	150.0	°C
T_{STG}	SR	Storage temperature range		-55.0	150.0	°C
T_{SDR}	SR	Maximum solder temperature ¹³		—	260.0	°C
MSL	SR	Moisture sensitivity level ¹⁴		—	3	

¹ Functional operating conditions are given in the DC electrical specifications. Absolute maximum ratings are stress ratings only, and functional operation at the maxima is not guaranteed. Stress beyond the listed maxima may affect device reliability or cause permanent damage to the device.

² Allowed 2 V for 10 hours cumulative time, remaining time at 1.2 V +10%.

³ The V_{FLASH} supply is connected to V_{RC33} in the package substrate. This specification applies to calibration package devices only.

⁴ Allowed 5.3 V for 10 hours cumulative time, remaining time at 3.3 V +10%.

⁵ Allowed 5.9 V for 10 hours cumulative time, remaining time at 5 V +10%.

- ⁶ All functional non-supply I/O pins are clamped to V_{SS} and V_{DDE} , or V_{DDEH} .
- ⁷ AC signal overshoot and undershoot of up to 2.0 V of the input voltages is permitted for an accumulative duration of 60 hours over the complete lifetime of the device (injection current not limited for this duration).
- ⁸ Internal structures hold the voltage greater than -1.0 V if the injection current limit of 2 mA is met.
- ⁹ Internal structures hold the input voltage less than the maximum voltage on all pads powered by V_{DDEH} supplies, if the maximum injection current specification is met (2 mA for all pins) and V_{DDEH} is within the operating voltage specifications.
- ¹⁰ Internal structures hold the input voltage less than the maximum voltage on all pads powered by V_{DDE} supplies, if the maximum injection current specification is met (2 mA for all pins) and V_{DDE} is within the operating voltage specifications.
- ¹¹ Total injection current for all pins (including both digital and analog) must not exceed 25 mA.
- ¹² Total injection current for all analog input pins must not exceed 15 mA.
- ¹³ Solder profile per IPC/JEDEC J-STD-020D.
- ¹⁴ Moisture sensitivity per JEDEC test method A112.

3.3 Thermal characteristics

Table 9. Thermal characteristics for 176-pin QFP¹

Symbol	C	D	Parameter	Conditions	Value	Unit
$R_{\theta JA}$	CC	D	Junction-to-Ambient, Natural Convection ²	Single layer board - 1s	38	°C/W
$R_{\theta JA}$	CC	D	Junction-to-Ambient, Natural Convection ²	Four layer board - 2s2p	31	°C/W
$R_{\theta JMA}$	CC	D	Junction-to-Moving-Air, Ambient ²	200 ft./min., single layer board - 1s	30	°C/W
$R_{\theta JMA}$	CC	D	Junction-to-Moving-Air, Ambient ²	at 200 ft./min., four layer board - 2s2p	25	°C/W
$R_{\theta JB}$	CC	D	Junction-to-Board ³		20	°C/W
$R_{\theta JCTop}$	CC	D	Junction-to-Case ⁴		5	°C/W
Ψ_{JT}	CC	D	Junction-to-Package Top, Natural Convection ⁵		2	°C/W

- ¹ Thermal characteristics are targets based on simulation that are subject to change per device characterization.
- ² Junction-to-Ambient Thermal Resistance determined per JEDEC JESD51-3 and JESD51-6. Thermal test board meets JEDEC specification for this package.
- ³ Junction-to-Board thermal resistance determined per JEDEC JESD51-8. Thermal test board meets JEDEC specification for the specified package.
- ⁴ Junction-to-Case at the top of the package determined using MIL-STD 883 Method 1012.1. The cold plate temperature is used for the case temperature. Reported value includes the thermal resistance of the interface layer.
- ⁵ Thermal characterization parameter indicating the temperature difference between the package top and the junction temperature per JEDEC JESD51-2. When Greek letters are not available, the thermal characterization parameter is written as Psi-JT.

Table 10. Thermal characteristics for 208-pin MAPBGA¹

Symbol		C	Parameter	Conditions	Value	Unit
R _{θJA}	CC	D	Junction-to-Ambient, Natural Convection ^{2,3}	One layer board - 1s	39	°C/W
R _{θJA}	CC	D	Junction-to-Ambient, Natural Convection ^{2,4}	Four layer board - 2s2p	24	°C/W
R _{θJMA}	CC	D	Junction-to-Moving-Air, Ambient ^{2,4}	at 200 ft./min., one layer board	31	°C/W
R _{θJMA}	CC	D	Junction-to-Moving-Air, Ambient ^{2,4}	at 200 ft./min., four layer board 2s2p	20	°C/W
R _{θJB}	CC	D	Junction-to-board ⁵	Four layer board - 2s2p	13	°C/W
R _{θJC}	CC	D	Junction-to-case ⁶		6	°C/W
Ψ _{JT}	CC	D	Junction-to-package top natural convection ⁷		2	°C/W

¹ Thermal characteristics are targets based on simulation that are subject to change per device characterization.

² Junction temperature is a function of die size, on-chip power dissipation, package thermal resistance, mounting site (board) temperature, ambient temperature, air flow, power dissipation of other components on the board, and board thermal resistance.

³ Per SEMI G38-87 and JEDEC JESD51-2 with the single-layer board horizontal.

⁴ Per JEDEC JESD51-6 with the board horizontal.

⁵ Thermal resistance between the die and the printed circuit board per JEDEC JESD51-8. Board temperature is measured on the top surface of the board near the package.

⁶ Indicates the average thermal resistance between the die and the case top surface as measured by the cold plate method (MIL SPEC-883 Method 1012.1) with the cold plate temperature used for the case temperature.

⁷ Thermal characterization parameter indicating the temperature difference between package top and the junction temperature per JEDEC JESD51-2. When Greek letters are not available, the thermal characterization parameter is written as Psi-JT.

Table 11. Thermal characteristics for 324-pin TEPBGA¹

Symbol		C	Parameter	Conditions	Value	Unit
R _{θJA}	CC	D	Junction-to-Ambient, Natural Convection ²	Single layer board - 1s	29	°C/W
R _{θJA}	CC	D	Junction-to-Ambient, Natural Convection ²	Four layer board - 2s2p	19	°C/W
R _{θJMA}	CC	D	Junction-to-Moving-Air, Ambient ²	at 200 ft./min., single layer board	23	°C/W
R _{θJMA}	CC	D	Junction-to-Moving-Air, Ambient ²	at 200 ft./min., four layer board 2s2p	16	°C/W
R _{θJB}	CC	D	Junction-to-Board ³		10	°C/W
R _{θJctop}	CC	D	Junction-to-Case ⁴		7	°C/W
Ψ _{JT}	CC	D	Junction-to-Package Top, Natural Convection ⁵		2	°C/W

¹ Thermal characteristics are targets based on simulation that are subject to change per device characterization.

² Junction-to-Ambient Thermal Resistance determined per JEDEC JESD51-3 and JESD51-6. Thermal test board meets JEDEC specification for this package.

³ Junction-to-Board thermal resistance determined per JEDEC JESD51-8. Thermal test board meets JEDEC specification for the specified package.

⁴ Junction-to-Case at the top of the package determined using MIL-STD 883 Method 1012.1. The cold plate temperature is used for the case temperature. Reported value includes the thermal resistance of the interface layer.

⁵ Thermal characterization parameter indicating the temperature difference between the package top and the junction temperature per JEDEC JESD51-2. When Greek letters are not available, the thermal characterization parameter is written as Psi-JT.

3.3.1 General notes for specifications at maximum junction temperature

An estimation of the chip junction temperature, T_J , can be obtained from the equation:

$$T_J = T_A + (R_{\theta JA} * P_D) \quad \text{Eqn. 1}$$

where:

- T_A = ambient temperature for the package ($^{\circ}\text{C}$)
- $R_{\theta JA}$ = junction-to-ambient thermal resistance ($^{\circ}\text{C}/\text{W}$)
- P_D = power dissipation in the package (W)

The thermal resistance values used are based on the JEDEC JESD51 series of standards to provide consistent values for estimations and comparisons. The difference between the values determined for the single-layer (1s) board compared to a four-layer board that has two signal layers, a power and a ground plane (2s2p), demonstrate that the effective thermal resistance is not a constant. The thermal resistance depends on the:

- Construction of the application board (number of planes)
- Effective size of the board which cools the component
- Quality of the thermal and electrical connections to the planes
- Power dissipated by adjacent components

Connect all the ground and power balls to the respective planes with one via per ball. Using fewer vias to connect the package to the planes reduces the thermal performance. Thinner planes also reduce the thermal performance. When the clearance between the vias leave the planes virtually disconnected, the thermal performance is also greatly reduced.

As a general rule, the value obtained on a single-layer board is within the normal range for the tightly packed printed circuit board. The value obtained on a board with the internal planes is usually within the normal range if the application board has:

- One oz. (35 micron nominal thickness) internal planes
- Components are well separated
- Overall power dissipation on the board is less than $0.02 \text{ W}/\text{cm}^2$

The thermal performance of any component depends on the power dissipation of the surrounding components. In addition, the ambient temperature varies widely within the application. For many natural convection and especially closed box applications, the board temperature at the perimeter (edge) of the package is approximately the same as the local air temperature near the device. Specifying the local ambient conditions explicitly as the board temperature provides a more precise description of the local ambient conditions that determine the temperature of the device.

At a known board temperature, the junction temperature is estimated using the following equation:

$$T_J = T_B + (R_{\theta JB} * P_D) \quad \text{Eqn. 2}$$

where:

- T_B = board temperature for the package perimeter ($^{\circ}\text{C}$)
- $R_{\theta JB}$ = junction-to-board thermal resistance ($^{\circ}\text{C}/\text{W}$) per JESD51-8S
- P_D = power dissipation in the package (W)

When the heat loss from the package case to the air does not factor into the calculation, an acceptable value for the junction temperature is predictable. Ensure the application board is similar to the thermal test condition, with the component soldered to a board with internal planes.

The thermal resistance is expressed as the sum of a junction-to-case thermal resistance plus a case-to-ambient thermal resistance:

$$R_{\theta JA} = R_{\theta JC} + R_{\theta CA} \quad \text{Eqn. 3}$$

where:

$R_{\theta JA}$ = junction-to-ambient thermal resistance ($^{\circ}\text{C}/\text{W}$)

$R_{\theta JC}$ = junction-to-case thermal resistance ($^{\circ}\text{C}/\text{W}$)

$R_{\theta CA}$ = case to ambient thermal resistance ($^{\circ}\text{C}/\text{W}$)

$R_{\theta JC}$ is device related and is not affected by other factors. The thermal environment can be controlled to change the case-to-ambient thermal resistance, $R_{\theta CA}$. For example, change the air flow around the device, add a heat sink, change the mounting arrangement on the printed circuit board, or change the thermal dissipation on the printed circuit board surrounding the device. This description is most useful for packages with heat sinks where 90% of the heat flow is through the case to heat sink to ambient. For most packages, a better model is required.

A more accurate two-resistor thermal model can be constructed from the junction-to-board thermal resistance and the junction-to-case thermal resistance. The junction-to-case thermal resistance describes when using a heat sink or where a substantial amount of heat is dissipated from the top of the package. The junction-to-board thermal resistance describes the thermal performance when most of the heat is conducted to the printed circuit board. This model can be used to generate simple estimations and for computational fluid dynamics (CFD) thermal models.

To determine the junction temperature of the device in the application on a prototype board, use the thermal characterization parameter (Ψ_{JT}) to determine the junction temperature by measuring the temperature at the top center of the package case using the following equation:

$$T_J = T_T + (\Psi_{JT} \times P_D) \quad \text{Eqn. 4}$$

where:

T_T = thermocouple temperature on top of the package ($^{\circ}\text{C}$)

Ψ_{JT} = thermal characterization parameter ($^{\circ}\text{C}/\text{W}$)

P_D = power dissipation in the package (W)

The thermal characterization parameter is measured in compliance with the JESD51-2 specification using a 40-gauge type T thermocouple epoxied to the top center of the package case. Position the thermocouple so that the thermocouple junction rests on the package. Place a small amount of epoxy on the thermocouple junction and approximately 1 mm of wire extending from the junction. Place the thermocouple wire flat against the package case to avoid measurement errors caused by the cooling effects of the thermocouple wire.

References:

Semiconductor Equipment and Materials International

3081 Zanker Road
San Jose, CA 95134
USA
(408) 943-6900

MIL-SPEC and EIA/JESD (JEDEC) specifications are available from Global Engineering Documents at 800-854-7179 or 303-397-7956.

JEDEC specifications are available on the WEB at <http://www.jedec.org>.

- C.E. Triplett and B. Joiner, "An Experimental Characterization of a 272 PBGA Within an Automotive Engine Controller Module," Proceedings of SemiTherm, San Diego, 1998, pp. 47-54.
- G. Kromann, S. Shidore, and S. Addison, "Thermal Modeling of a PBGA for Air-Cooled Applications", Electronic Packaging and Production, pp. 53-58, March 1998.

- B. Joiner and V. Adams, “Measurement and Simulation of Junction to Board Thermal Resistance and Its Application in Thermal Modeling,” Proceedings of SemiTherm, San Diego, 1999, pp. 212-220.

3.4 EMI (electromagnetic interference) characteristics

Table 12. EMI Testing Specifications¹

Symbol	Parameter	Conditions	Clocks	Frequency Range	Level (Max)	Unit	
Radiated emissions, electric field	V _{RE_TEM}	V _{DDREG} = 5.25 V; T _A = 25 °C 150 kHz – 30 MHz RBW 9 kHz, Step Size 5 kHz	16 MHz crystal 40 MHz bus No PLL frequency modulation	150 kHz – 50 MHz	20	dB μ V	
				50 – 150 MHz	20		
				150 – 500 MHz	26		
				500 – 1000 MHz	26		
				IEC Level	K		—
				SAE Level	3		—
		30 MHz – 1 GHz - RBW 120 kHz, Step Size 80 kHz	16 MHz crystal 40 MHz bus \pm 2% PLL frequency modulation	150 kHz– 50 MHz	13	dB μ V	
				50 – 150 MHz	13		
				150 – 500 MHz	11		
				500 – 1000 MHz	13		
				IEC Level	L		—
				SAE Level	2		—

¹ EMI testing and I/O port waveforms per SAE J1752/3 issued 1995-03 and IEC 61967-2.

3.5 Electrostatic discharge (ESD) characteristics

Table 13. ESD ratings^{1,2}

Symbol	Parameter	Conditions	Value	Unit	
—	SR	ESD for Human Body Model (HBM)	—	2000 V	
R1	SR	HBM circuit description	—	1500 Ω	
C	SR		—	100 pF	
—	SR	ESD for field induced charge Model (FDCM)	All pins	500 V	
			Corner pins	750	
—	SR	Number of pulses per pin	Positive pulses (HBM)	1	—
			Negative pulses (HBM)	1	—
—	SR	Number of pulses	—	1	—

¹ All ESD testing is in conformity with CDF-AEC-Q100 Stress Test Qualification for Automotive Grade Integrated Circuits.

- ² Device failure is defined as: “If after exposure to ESD pulses, the device does not meet the device specification requirements, which includes the complete DC parametric and functional testing at room temperature and hot temperature.”

3.6 Power management control (PMC) and power on reset (POR) electrical specifications

Table 14. PMC Operating Conditions and External Regulators Supply Voltage

ID	Name			Parameter	Min	Typ	Max	Unit
1	Jtemp	SR	—	Junction temperature	−40	27	150	°C
2	Vddreg	SR	—	PMC 5 V supply voltage V_{DDREG}	4.75	5	5.25	V
3	Vdd	SR	—	Core supply voltage 1.2 V V_{DD} when external regulator is used without disabling the internal regulator (PMC unit turned on, LVI monitor active) ¹	1.26 ²	1.3	1.32	V
3a	—	SR	—	Core supply voltage 1.2 V V_{DD} when external regulator is used with a disabled internal regulator (PMC unit turned-off, LVI monitor disabled)	1.14	1.2	1.32	V
4	Ivdd	SR	—	Voltage regulator core supply maximum required DC output current	400	—	—	mA
5	Vdd33	SR	—	Regulated 3.3 V supply voltage when external regulator is used without disabling the internal regulator (PMC unit turned-on, internal 3.3V regulator enabled, LVI monitor active) ³	3.3	3.45	3.6	V
5a	—	SR	—	Regulated 3.3 V supply voltage when external regulator is used with a disabled internal regulator (PMC unit turned-off, LVI monitor disabled)	3	3.3	3.6	V
6	—	SR	—	Voltage regulator 3.3 V supply maximum required DC output current	80	—	—	mA

¹ An internal regulator controller can be used to regulate core supply.

² The minimum supply required for the part to exit reset and enter in normal run mode is 1.28 V.

³ An internal regulator can be used to regulate 3.3 V supply.

Table 15. PMC Electrical Characteristics

ID	Name			Parameter	Min	Typ	Max	Unit	Notes
1	VBG	CC	C	Nominal bandgap voltage reference	—	1.219	—	V	
1a	—	CC	P	Untrimmed bandgap reference voltage	VBG - 7%	VBG	Vbg + 6%	V	
1b	—	CC	P	Trimmed bandgap reference voltage (5 V, 27 °C)	VBG -10mV	VBG	VBG + 10mV	V	
1c	—	CC	C	Bandgap reference temperature variation	—	100	—	ppm /°C	
1d	—	CC	C	Bandgap reference supply voltage variation	—	3000	—	ppm /V	
2	Vdd	CC	C	Nominal V _{DD} core supply internal regulator target DC output voltage ¹	—	1.28	—	V	
2a	—	CC	P	Nominal V _{DD} core supply internal regulator target DC output voltage variation at power-on reset	Vdd - 6%	Vdd	Vdd + 10%	V	
2b	—	CC	P	Nominal V _{DD} core supply internal regulator target DC output voltage variation after power-on reset	Vdd - 10% ²	Vdd	Vdd + 3%	V	
2c	—	CC	C	Trimming step Vdd	—	20	—	mV	
2d	lvrctl	CC	C	Voltage regulator controller for core supply maximum DC output current	20	—	—	mA	
3	Lvi1p2	CC	C	Nominal LVI for rising core supply ³	—	1.160	—	V	
3a	—	CC	C	Variation of LVI for rising core supply at power-on reset	1.120	1.200	1.280	V	See note ⁴
3b	—	CC	C	Variation of LVI for rising core supply after power-on reset	Lvi1p2 - 3%	Lvi1p2	Lvi1p2 + 3%	V	See note ⁴
3c	—	CC	C	Trimming step LVI core supply	—	20	—	mV	
3d	Lvi1p2_h	CC	C	LVI core supply hysteresis	—	40	—	mV	
4	Por1.2V_r	CC	C	POR 1.2 V rising	—	0.709	—	V	
4a	—	CC	C	POR 1.2 V rising variation	Por1.2V_r - 35%	Por1.2V_r	Por1.2V_r + 35%	V	
4b	Por1.2V_f	CC	C	POR 1.2 V falling	—	0.638	—	V	
4c	—	CC	C	POR 1.2 V falling variation	Por1.2V_f - 35%	Por1.2V_f	Por1.2V_f + 35%	V	

Table 15. PMC Electrical Characteristics (continued)

ID	Name			Parameter	Min	Typ	Max	Unit	Notes
5	Vdd33	CC	C	Nominal 3.3 V supply internal regulator DC output voltage	—	3.39	—	V	
5a	—	CC	P	Nominal 3.3 V supply internal regulator DC output voltage variation at power-on reset	Vdd33 - 8.5%	Vdd33	Vdd3 + 7%	V	See note ⁵
5b	—	CC	P	Nominal 3.3 V supply internal regulator DC output voltage variation power-on reset	Vdd33 - 7.5%	Vdd33	Vdd33 + 7%	V	With internal load up to Idd3p3
5c	—	CC	D	Voltage regulator 3.3 V output impedance at maximum DC load	—	—	2	Ω	
5d	Idd3p3	CC	P	Voltage regulator 3.3 V maximum DC output current (internal regulator enabled) ⁶	80 ⁷	—	—	mA	
5e	Vdd33 ILim	CC	C	Voltage regulator 3.3 V DC current limit	—	130	—	mA	
6	Lvi3p3	CC	C	Nominal LVI for rising 3.3 V supply	—	3.090	—	V	The Lvi3p3 specs are also valid for the Vddeb LVI
6a	—	CC	C	Variation of LVI for rising 3.3 V supply at power-on reset	Lvi3p3 - 6%	Lvi3p3	Lvi3p3 + 6%	V	See note ⁸
6b	—	CC	C	Variation of LVI for rising 3.3 V supply after power-on reset	Lvi3p3 - 3%	Lvi3p3	Lvi3p3 + 3%	V	See note ⁸
6c	—	CC	C	Trimming step LVI 3.3 V	—	20	—	mV	
6d	Lvi3p3_h	CC	C	LVI 3.3 V hysteresis	—	60	—	mV	
7	Por3.3V_r	CC	C	Nominal POR for rising 3.3 V supply	—	2.07	—	V	The 3.3V POR specs are also valid for the V _{DDEH} POR
7a	—	CC	C	Variation of POR for rising 3.3 V supply	Por3.3V_r - 35%	Por3.3V_r	Por3.3V_r + 35%	V	
7b	Por3.3V_f	CC	C	Nominal POR for falling 3.3 V supply	—	1.95	—	V	
7c	—	CC	C	Variation of POR for falling 3.3 V supply	Por3.3V_f - 35%	Por3.3V_f	Por3.3V_f + 35%	V	
8	Lvi5p0	CC	C	Nominal LVI for rising 5 V V _{DDREG} supply	—	4.290	—	V	

Table 15. PMC Electrical Characteristics (continued)

ID	Name		Parameter	Min	Typ	Max	Unit	Notes
8a	—	CC C	Variation of LVI for rising 5 V V _{DDREG} supply at power-on reset	Lvi5p0 - 6%	Lvi5p0	Lvi5p0 + 6%	V	
8b	—	CC C	Variation of LVI for rising 5 V V _{DDREG} supply power-on reset	Lvi5p0 - 3%	Lvi5p0	Lvi5p0 + 3%	V	
8c	—	CC C	Trimming step LVI 5 V	—	20	—	mV	
8d	Lvi5p0_h	CC C	LVI 5 V hysteresis	—	60	—	mV	
9	Por5V_r	CC C	Nominal POR for rising 5 V V _{DDREG} supply	—	2.67	—	V	
9a	—	CC C	Variation of POR for rising 5 V V _{DDREG} supply	Por5V_r - 35%	Por5V_r	Por5V_r + 50%	V	
9b	Por5V_f	CC C	Nominal POR for falling 5 V V _{DDREG} supply	—	2.47	—	V	
9c	—	CC C	Variation of POR for falling 5 V V _{DDREG} supply	Por5V_f - 35%	Por5V_f	Por5V_f + 50%	V	

¹ Using external ballast transistor.

² Min range is extended to 10% since Lvi1p2 is reprogrammed from 1.2 V to 1.16 V after power-on reset.

³ LVI for falling supply is calculated as LVI rising – LVI hysteresis.

⁴ Lvi1p2 tracks DC target variation of internal V_{dd} regulator. Minimum and maximum Lvi1p2 correspond to minimum and maximum V_{dd} DC target respectively.

⁵ Minimum loading (<10 mA) for reading trim values from flash, powering internal RC oscillator, and IO consumption during POR.

⁶ No external load is allowed, except for use as a reference for an external tool.

⁷ This value is valid only when the internal regulator is bypassed. When the internal regulator is enabled, the maximum external load allowed on the Nexus pads is 30 pF at 40 MHz.

⁸ Lvi3p3 tracks DC target variation of internal V_{dd33} regulator. Minimum and maximum Lvi3p3 correspond to minimum and maximum V_{dd33} DC target respectively.

3.6.1 Voltage regulator controller (V_{RC}) electrical specifications

Table 16. VRC electrical specifications

Symbol	Parameter	Min.	Max.	Units
I _{VRCTL} ¹	Current can be sourced by V _{RCCTL} at T _j :	25 °C	TBD	— mA
		150 °C	TBD	— mA
BETA ²	Required gain at T _j : I _{DD} ÷ I _{VRCTL} (f _{sys} = f _{MAX}) ^{1,3,4}	– 40 °C	TBD	—
		25 °C	TBD	—
		150 °C	TBD	TBD

¹ I_{VRCTL} is measured at the following conditions: V_{DD} = 1.35 V, V_{RC33} = 3.1 V, V_{VRCTL} = 2.2 V.

- ² BETA represents the worst-case external transistor. It is measured on a per-part basis and calculated as $(I_{DD} \div I_{VRCTL})$.
- ³ Refer to [Table 52](#) for the maximum operating frequency.
- ⁴ Values are based on I_{DD} from high-use applications as explained in the I_{DD} Electrical Specification.

3.6.2 Regulator Example

In designs where the MPC5644A microcontroller's internal regulators are used, a ballast is required for generation of the 1.2 V internal supply. No ballast is required when an external 1.2 V supply is used.

The resistor may or may not be required. This depends on the allowable power dissipation of the npn bypass transistor device. The resistor may be used to limit the in-rush current at power on.

The bypass transistor MUST be operated out of saturation region.

Mandatory decoupling capacitor network

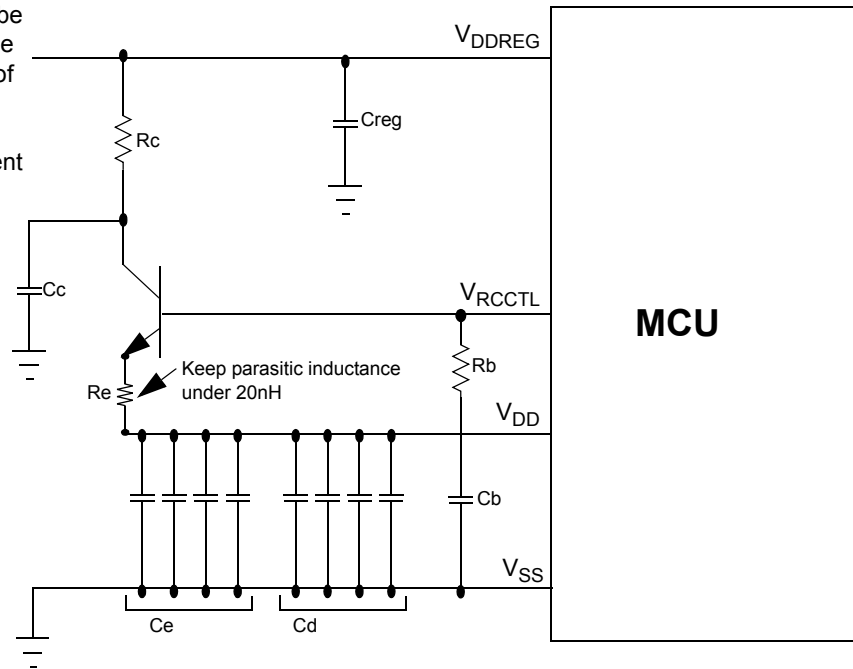

VRCTL capacitor and resistor is required

Figure 8. Core voltage regulator controller external components preferred configuration

Table 17. MPC5644A External network specification

External Network Parameter	Min	Typ	Max	Comment
T1				NJD2873 or BCP68 only
Cb	1.1 μ F	2.2 μ F	2.97 μ F	X7R, -50%/+35%
Ce	3*2.35 μ F+5 μ F	3*4.7 μ F+10 μ F	3*6.35 μ F+13.5 μ F	X7R, -50%/+35%
Equivalent ESR of Ce capacitors	5m Ω		50m Ω	
Cd	4*50nF	4*100nF	4*135nF	X7R, -50%/+35%
Rb	9 Ω	10 Ω	11 Ω	+/-10%

Table 17. MPC5644A External network specification

External Network Parameter	Min	Typ	Max	Comment
Re	0.252 Ω	0.280 Ω	0.308 Ω	+/-10%
Creg		10 μF		It depends on external Vreg.
Cc	5 μF	10 μF	13.5 μF	X7R, -50%/+35%
Rc	1.1 Ω		5.6 Ω	May or may not be required. It depends on the allowable power dissipation of T1.

3.6.3 Recommended power transistors

The following NPN transistors are recommended for use with the on-chip voltage regulator controller: ON Semiconductor™ BCP68T1 or NJD2873 as well as Philips Semiconductor™ BCP68. The collector of the external transistor is preferably connected to the same voltage supply source as the output stage of the regulator.

Table 18. Recommended operating characteristics

Symbol	Parameter	Value	Unit
$h_{FE} (\beta)$	DC current gain (Beta)	60 – 550	—
P_D	Absolute minimum power dissipation	>1.0 (1.5 preferred)	W
I_{CMaxDC}	Minimum peak collector current	1.0	A
$V_{CE_{SAT}}$	Collector-to-emitter saturation voltage	200 – 600 ¹	mV
V_{BE}	Base-to-emitter voltage	0.4 – 1.0	V

¹ Adjust resistor at bipolar transistor collector for 3.3 V/5.0 V to avoid $V_{CE} < V_{CE_{SAT}}$.

3.7 Power up/down sequencing

There is no power sequencing required among power sources during power up and power down, in order to operate within specification.

Although there are no power up/down sequencing requirements to prevent issues such as latch-up or excessive current spikes the state of the I/O pins during power up/down varies according to [Table 19](#) for all pins with fast pads, and [Table 20](#) for all pins with medium, slow, and multi-voltage pads.

Table 19. Power sequence pin states (fast pads)

V_{DDE}	V_{RC33}	V_{DD}	Pad State
LOW	X	X	LOW
V_{DDE}	LOW	X	HIGH
V_{DDE}	V_{RC33}	LOW	HIGH IMPEDANCE
V_{DDE}	V_{RC33}	V_{DD}	FUNCTIONAL

Table 20. Power sequence pin states (medium, slow, and multi-voltage pads)

V_{DDEH}	V_{DD}	Pad State
LOW	X	LOW
V_{DDEH}	LOW	HIGH IMPEDANCE
V_{DDEH}	V_{DD}	FUNCTIONAL

3.8 DC electrical specifications

Table 21. DC electrical specifications

Symbol	C	Parameter	Conditions	Value			Unit	
				min	typ	max		
V_{DD}	SR	—	Core supply voltage	—	1.14		1.32	V
V_{DDE}	SR	—	I/O supply voltage	—	1.62		3.6	V
V_{DDEH}	SR	—	I/O supply voltage	—	3.0		5.25	V
V_{DDE-EH}	SR	—	I/O supply voltage	—	3.0		5.25	V
V_{RC33}	SR	—	3.3 V regulated voltage ¹	—	3.0	—	3.6	V
V_{DDA}	SR	—	Analog supply voltage	—	4.75 ²	—	5.25	V
V_{INDC}	SR	—	Analog input voltage	—	$V_{SSA}-0.3$	—	$V_{DDA}+0.3$	V
$V_{SS} - V_{SSA}$	SR	—	V_{SS} differential voltage	—	-100	—	100	mV
V_{RL}	SR	—	Analog reference low voltage	—	V_{SSA}	—	$V_{SSA}+0.1$	V
$V_{RL} - V_{SSA}$	SR	—	V_{RL} differential voltage	—	-100	—	100	mV
V_{RH}	SR	—	Analog reference high voltage	—	$V_{DDA}-0.1$	—	V_{DDA}	V
$V_{RH} - V_{RL}$	SR	—	V_{REF} differential voltage	—	4.75	—	5.25	V
V_{DDF}	SR	—	Flash operating voltage ³	—	1.14	—	1.32	V
V_{FLASH}^4	SR	—	Flash read voltage	—	3.0	—	3.6	V
V_{STBY}	SR	—	SRAM standby voltage	Unregulated mode	0.95	—	1.2	V
			Keep-out Range: 1.2V–2V	Regulated mode	2.0	—	5.5	

Table 21. DC electrical specifications (continued)

Symbol		C	Parameter	Conditions	Value			Unit
					min	typ	max	
V_{DDREG}	SR	—	Voltage regulator supply voltage	—	4.75	—	5.25	V
V_{DDPLL}	SR	—	Clock synthesizer operating voltage	—	1.14	—	1.32	V
$V_{SSPLL} - V_{SS}$	SR	—	V_{SSPLL} to V_{SS} differential voltage	—	-100	—	100	mV
V_{IL_S}	CC	C	Slow/medium I/O pad input low voltage	Hysteresis enabled	$V_{SS}-0.3$	—	$0.35 \cdot V_{DDEH}$	V
		P		Hysteresis disabled	$V_{SS}-0.3$	—	$0.40 \cdot V_{DDEH}$	
V_{IL_F}	CC	C	Fast pad I/O input low voltage	Hysteresis enabled	$V_{SS}-0.3$	—	$0.35 \cdot V_{DDE}$	V
		P		Hysteresis disabled	$V_{SS}-0.3$	—	$0.40 \cdot V_{DDE}$	
V_{IL_LS}	CC	C	Multi-voltage I/O pad input low voltage in Low-swing-mode ^{5,6,7,8}	Hysteresis enabled	$V_{SS}-0.3$	—	0.8	V
		P		Hysteresis disabled	$V_{SS}-0.3$	—	1.1	
V_{IL_HS}	CC	C	Multi-voltage pad I/O input low voltage in high-swing-mode	Hysteresis enabled	$V_{SS}-0.3$	—	$0.35 V_{DDEH}$	V
		P		Hysteresis disabled	$V_{SS}-0.3$	—	$0.4 V_{DDEH}$	
V_{IH_S}	CC	C	Slow/medium pad I/O input high voltage ⁹	Hysteresis enabled	$0.65 V_{DDEH}$	—	$V_{DDEH}+0.3$	V
		P		Hysteresis disabled	$0.55 V_{DDEH}$	—	$V_{DDEH}+0.3$	
V_{IH_F}	CC	C	Fast I/O input high voltage	Hysteresis enabled	$0.65 V_{DDE}$	—	$V_{DDE}+0.3$	V
		P		Hysteresis disabled	$0.58 V_{DDE}$	—	$V_{DDE}+0.3$	
V_{IH_LS}	CC	C	Multi-voltage pad I/O input high voltage in low-swing-mode ^{5,6,7,8}	Hysteresis enabled	2.5	—	$V_{DDEH}+0.3$	V
		P		Hysteresis disabled	2.2	—	$V_{DDEH}+0.3$	
V_{IH_HS}	CC	C	Multi-voltage I/O input high voltage in high-swing-mode	Hysteresis enabled	$0.65 V_{DDEH}$	—	$V_{DDEH}+0.3$	V
		P		Hysteresis disabled	$0.55 V_{DDEH}$	—	$V_{DDEH}+0.3$	

Table 21. DC electrical specifications (continued)

Symbol		C	Parameter	Conditions	Value			Unit
					min	typ	max	
V_{OL_S}	CC	P	Slow/medium pad I/O output low voltage ⁹		—	—	$0.2 \cdot V_{DDEH}$	V
V_{OL_F}	CC	P	Fast I/O output low voltage ⁹		—	—	$0.2 \cdot V_{DDE}$	V
V_{OL_LS}	CC	P	Multi-voltage pad I/O output low voltage in low-swing mode ^{5,6,7,8,9}		—	—	0.6	V
V_{OL_HS}	CC	P	Multi-voltage pad I/O output low voltage in high-swing mode ⁹		—	—	$0.2 \cdot V_{DDEH}$	V
V_{OH_S}	CC	P	Slow/medium pad I/O output high voltage ⁹		$0.8 V_{DDEH}$	—	—	V
V_{OH_F}	CC	P	Fast pad I/O output high voltage ⁹		$0.8 V_{DDE}$	—	—	V
V_{OH_LS}	CC	P	Multi-voltage pad I/O output high voltage in low-swing mode ^{5,6,7,8}	$I_{OH_LS} = 0.5 \text{ mA}$	2.1	3.1	3.7	V
V_{OH_HS}	CC	P	Multi-voltage pad I/O output high voltage in high-swing mode ⁹		$0.8 V_{DDEH}$	—	—	V
V_{HYS_S}	CC	C	Slow/medium/multi-voltage I/O input hysteresis	—	$0.1 \cdot V_{DDEH}$	—	—	V
V_{HYS_F}	CC	C	Fast I/O input hysteresis	—	$0.1 \cdot V_{DDE}$	—	—	V
V_{HYS_LS}	CC	C	Low-Swing-Mode Multi-Voltage I/O Input Hysteresis	hysteresis enabled	0.25	—	—	v
$I_{DD} + I_{DDPLL}$	CC	P	Operating current 1.2 V supplies	V_{DD} at 1.32 V at 80 MHz	—		380	mA
		P		V_{DD} at 1.32V at 120 MHz	—		400	mA
		P		V_{DD} at 1.32V at 150 MHz	—		400	mA

Table 21. DC electrical specifications (continued)

Symbol		C	Parameter	Conditions	Value			Unit
					min	typ	max	
I _{DDSTBY}	CC	T	Operating current 0.95-1.2 V	V _{STBY} at 55 °C	—	35	100	μA
		T	Operating current 2-5.5 V	V _{STBY} at 55 °C	—	45	110	μA
I _{DDSTBY27}	CC	P	Operating current 0.95-1.2 V	V _{STBY} 27 °C		25	90	μA
		P	Operating current 2-5.5 V	V _{STBY} 27 °C		35	100	μA
I _{DDSTBY150}	CC	P	Operating current 0.95-1.2 V	V _{STBY} 150 °C	—	790	2000	μA
		P	Operating current 2-5.5 V	V _{STBY} at 150 °C	—	760	2000	μA
I _{DDPLL}	CC	P	Operating current 1.2 V supplies	V _{DDPLL} , 80 MHz, V _{DD} =1.2 V	—		15	mA
I _{DDSLow} I _{DDSTOP}	CC	P	V _{DD} low-power mode operating current at 1.32 V	Slow mode ¹⁰	—		90	mA
		P		Stop mode ¹¹	—		75	
I _{DD33}	CC	C	Operating current 3.3 V supplies	V _{RC33} ^{1, 12}	—		60	mA
I _{DDA} I _{REF} I _{DDREG}	CC	P	Operating current 5.0 V supplies	V _{DDA}	—	—	30.0	mA
		P		Analog reference supply current (transient)	—	—	1.0	
		C		V _{DDREG}	—	—	70 ¹³	
I _{DDH1} I _{DDH4} I _{DDH6} I _{DDH7} I _{DD7} I _{DDH9} I _{DD12}	CC	D	Operating current V _{DDE} ¹⁴ supplies	V _{DDEH1}	—	—	See note ¹⁴	mA
		D		V _{DDEH4}	—	—		
		D		V _{DDEH6}	—	—		
		D		V _{DDEH7}	—	—		
		D		V _{DDE7}	—	—		
		D		V _{DDEH9}	—	—		
		D		V _{DDE12}	—	—		

Table 21. DC electrical specifications (continued)

Symbol		C	Parameter	Conditions	Value			Unit
					min	typ	max	
I _{ACT_S}	CC	C	Slow/medium I/O weak pull up/down current ¹⁵	3.0 V – 3.6 V	15	—	95	μA
		P		4.75 V – 5.5 V	35	—	200	
I _{ACT_F}	CC	D	Fast I/O weak pull up/down current ¹⁵	1.62 V – 1.98 V	36	—	120	μA
		D		2.25 V – 2.75 V	34	—	139	
		D		3.0 V – 3.6 V	42	—	158	
I _{ACT_MV_PU}	CC	C	Multi-voltage pad weak pullup current	V _{DDE} = 3.0–3.6 V ⁵ , MultiV pad, high swing mode only	10	—	75	μA
		P		4.75 V – 5.25 V	25	—	200	
I _{ACT_MV_PD}	CC	C	Multivoltage pad weak pulldown current	V _{DDE} = 3.0–3.6 V ⁵ , MultiV pad, high swing mode only	10	—	60	μA
		P		4.75 V – 5.25 V	25	—	200	
I _{INACT_D}	CC	P	I/O input leakage current ¹⁶	—	–2.5	—	2.5	μA
I _{IC}	SR	T	DC injection current (per pin)	—	–1.0	—	1.0	mA
I _{INACT_A}	SR	P	Analog input current, channel off, AN[0:7] ¹⁷	—	–250	—	250	nA
		P	Analog input current, channel off, all other analog pins ¹⁷	—	–150	—	150	

Table 21. DC electrical specifications (continued)

Symbol		C	Parameter	Conditions	Value			Unit
					min	typ	max	
C _L	CC	D	Load capacitance (fast I/O) ¹⁸	DSC(PCR[8:9]) = 0b00	—		10	pF
		D		DSC(PCR[8:9]) = 0b01	—		20	
		D		DSC(PCR[8:9]) = 0b10	—		30	
		D		DSC(PCR[8:9]) = 0b11	—		50	
C _{IN}	CC	D	Input capacitance (digital pins)	—	—		7	pF
C _{IN_A}	CC	D	Input capacitance (analog pins)	—	—		10	pF
C _{IN_M}	CC	D	Input capacitance (digital and analog pins) ¹⁹	—	—		12	pF
R _{PUPD200K}	SR	P	Weak Pull-Up/Down Resistance ²⁰ , 200 kΩ Option	—	130	—	280	kΩ
R _{PUPD100K}	SR	P	Weak Pull-Up/Down Resistance ²⁰ , 100 kΩ Option	—	65	—	140	kΩ
R _{PUPD5K}	SR	C	Weak Pull-Up/Down Resistance ²⁰ , 5 kΩ Option	5 V ± 5% supply	1.4	—	7.5	kΩ
R _{PUPDMTCH}	CC	C	Pull-up/Down Resistance matching ratios (100K/200K)	Pull-up and pull-down resistances both enabled and settings are equal.	-2.5	—	2.5	%
T _A (T _L to T _H)	SR	—	Operating temperature range - ambient (packaged)	—	-40.0		125.0	°C
—	SR	—	Slew rate on power supply pins	—	—		25	V/ms

¹ These specifications apply when V_{RC33} is supplied externally, after disabling the internal regulator (V_{DDREG} = 0).

² ADC is functional with 4 V ≤ V_{DDA} ≤ 4.75 V but with derated accuracy. This means the ADC will continue to function at full speed with no undesirable behavior, but the accuracy will be degraded.

³ The V_{DDF} supply is connected to V_{DD} in the package substrate. This specification applies to calibration package devices only.

- 4 V_{FLASH} is only available in the calibration package.
- 5 Power supply for multi-voltage pads cannot be below 4.5 V when in low-swing mode.
- 6 The slew rate (SRC) setting must be 0b11 when in low-swing mode.
- 7 While in low-swing mode there are no restrictions in transitioning to high-swing mode.
- 8 Pin in low-swing mode can accept a 5 V input.
- 9 All V_{OL}/V_{OH} values 100% tested with ± 2 mA load except where noted.
- 10 Bypass mode, system clock at 1 MHz (using system clock divider), PLL shut down, CPU running simple executive code, 4 x ADC conversion every 10 ms, 2 x PWM channels 1 kHz, all other modules stopped.
- 11 Bypass mode, system clock at 1 MHz (using system clock divider), CPU stopped, PIT running, all other modules stopped.
- 12 This current will be consumed for external regulation and internal regulation, when 3.3V regulator is switched off by shadow flash
- 13 If 1.2V and 3.3V internal regulators are on, then $iddreg=70mA$
If supply is external that is 3.3V internal regulator is off, then $iddreg=15mA$
- 14 Power requirements for each I/O segment are dependent on the frequency of operation and load of the I/O pins on a particular I/O segment, and the voltage of the I/O segment. See [Table 22](#) for values to calculate power dissipation for specific operation. The total power consumption of an I/O segment is the sum of the individual power consumptions for each pin on the segment.
- 15 Absolute value of current, measured at V_{IL} and V_{IH} .
- 16 Weak pull up/down inactive. Measured at $V_{DDE} = 3.6$ V and $V_{DDEH} = 5.25$ V. Applies to fast, slow, and medium pads.
- 17 Maximum leakage occurs at maximum operating temperature. Leakage current decreases by approximately one-half for each 8 to 12 °C, in the ambient temperature range of 50 to 125 °C. Applies to analog pads.
- 18 Applies to CLKOUT, external bus pins, and Nexus pins.
- 19 Applies to the FCK, SDI, SDO, and \overline{SDS} pins.
- 20 This programmable option applies only to eQADC differential input channels and is used for biasing and sensor diagnostics.

3.9 I/O pad current specifications

The power consumption of an I/O segment depends on the usage of the pins on a particular segment. The power consumption is the sum of all output pin currents for a particular segment. The output pin current can be calculated from Table 22 based on the voltage, frequency, and load on the pin. Use linear scaling to calculate pin currents for voltage, frequency, and load parameters that fall outside the values given in Table 22.

Table 22. I/O pad average I_{DDE} specifications¹

Pad Type	Symbol	C	D	Period (ns)	Load ² (pF)	V _{DDE} (V)	Drive/Slew Rate Select	I _{DDE} Avg (mA) ³	I _{DDE} RMS (mA)
Slow	I _{DRV_SSR_HV}	CC	D	37	50	5.5	11	9	—
		CC	D	130	50	5.5	01	2.5	—
		CC	D	650	50	5.5	00	0.5	—
		CC	D	840	200	5.5	00	1.5	—
Medium	I _{DRV_MSR_HV}	CC	D	24	50	5.5	11	14	—
		CC	D	62	50	5.5	01	5.3	—
		CC	D	317	50	5.5	00	1.1	—
		CC	D	425	200	5.5	00	3	—
Fast	I _{DRV_FC}	CC	D	10	50	3.6	11	22.7	68.3
		CC	D	10	30	3.6	10	12.1	41.1
		CC	D	10	20	3.6	01	8.3	27.7
		CC	D	10	10	3.6	00	4.44	14.3
		CC	D	10	50	1.98	11	12.5	31
		CC	D	10	30	1.98	10	7.3	18.6
		CC	D	10	20	1.98	01	5.42	12.6
		CC	D	10	10	1.98	00	2.84	6.4
MultiV (High Swing Mode)	I _{DRV_MULTV_HV}	CC	D	20	50	5.5	11	9	—
		CC	D	30	50	5.5	01	6.1	—
		CC	D	117	50	5.5	00	2.3	—
		CC	D	212	200	5.5	00	5.8	—
MultiV (Low Swing Mode)	I _{DRV_MULTV_HV}	CC	D	30	30	5.5	11	3.4	—

¹ Numbers from simulations at best case process, 150 °C.

² All loads are lumped.

³ Average current is for pad configured as output only.

3.9.1 I/O pad V_{RC33} current specifications

The power consumption of the V_{RC33} supply is dependent on the usage of the pins on all I/O segments. The power consumption is the sum of all input and output pin V_{RC33} currents for all I/O segments. The output pin V_{RC33} current can be calculated from [Table 23](#) based on the voltage, frequency, and load on all fast pad pins. The input pin V_{RC33} current can be calculated from [Table 23](#) based on the voltage, frequency, and load on all medium-speed pads. Use linear scaling to calculate pin currents for voltage, frequency, and load parameters that fall outside the values given in [Table 23](#).

Table 23. I/O pad V_{RC33} average I_{DDE} specifications¹

Pad Type	Symbol	C	Period (ns)	Load ² (pF)	Drive Select	I_{DD33} Avg (μ A)	I_{DD33} RMS (μ A)	
Slow	$I_{DRV_SSR_HV}$	CC	D	100	50	11	0.8	235.7
		CC	D	200	50	01	0.04	87.4
		CC	D	800	50	00	0.06	47.4
		CC	D	800	200	00	0.009	47
Medium	$I_{DRV_MSR_HV}$	CC	D	40	50	11	2.75	258
		CC	D	100	50	01	0.11	76.5
		CC	D	500	50	00	0.02	56.2
		CC	D	500	200	00	0.01	56.2
MultiV ³ (High Swing Mode)	$I_{DRV_MULTV_HV}$	CC	D	20	50	11	33.4	35.4
		CC	D	30	50	01	33.4	34.8
		CC	D	117	50	00	33.4	33.8
		CC	D	212	200	00	33.4	33.7
MultiV ⁴ (Low Swing Mode)	$I_{DRV_MULTV_HV}$	CC	D	30	30	11	33.4	34.9

¹ These are typical values that are estimated from simulation and not tested. Currents apply to output pins only.

² All loads are lumped.

³ Average current is for pad configured as output only.

⁴ In low swing mode, multi-voltage pads must operate in highest slew rate setting.

Table 24. V_{RC33} pad average DC current¹

Pad Type	Symbol	C	Period (ns)	Load ² (pF)	V _{RC33} (V)	V _{DDE} (V)	Drive Select	I _{DD33} Avg (μA)	I _{DD33} RMS (μA)	
Fast	I _{DRV_FC}	CC	D	10	50	3.6	3.6	11	2.35	6.12
		CC	D	10	30	3.6	3.6	10	1.75	4.3
		CC	D	10	20	3.6	3.6	01	1.41	3.43
		CC	D	10	10	3.6	3.6	00	1.06	2.9
		CC	D	10	50	3.6	1.98	11	1.75	4.56
		CC	D	10	30	3.6	1.98	10	1.32	3.44
		CC	D	10	20	3.6	1.98	01	1.14	2.95
		CC	D	10	10	3.6	1.98	00	0.95	2.62

¹ These are typical values that are estimated from simulation and not tested. Currents apply to output pins only.

² All loads are lumped.

3.9.2 LVDS pad specifications

LVDS pads are implemented to support the MSC (Microsecond Channel) protocol which is an enhanced feature of the DSPI module. The LVDS pads are compliant with LVDS specifications and support data rates up to 50 MHz.

Table 25. DSPI LVDS pad specification

#	Characteristic	Symbol	C	Condition	Min. Value	Typ. Value	Max. Value	Unit	
Data Rate									
4	Data Frequency	f _{LVDSCLK}	CC	D	—	50		MHz	
Driver Specs									
5	Differential output voltage	V _{OD}	CC	P	SRC=0b00 or 0b11	150		400	mV
			CC	P	SRC=0b01	90		320	
			CC	P	SRC=0b10	160		480	
6	Common mode voltage (LVDS), VOS	V _{OD}	CC	P		1.06	1.2	1.39	V
7	Rise/Fall time	T _R /T _F	CC	D	—	2			ns
8	Propagation delay (Low to High)	T _{PLH}	CC	D		4			ns
9	Propagation delay (High to Low)	T _{PHL}	CC	D	—	4			ns
10	Delay (H/L), sync Mode	t _{PDSYNC}	CC	D		4			ns

Table 25. DSPI LVDS pad specification (continued)

11	Delay, Z to Normal (High/Low)	T_{DZ}	CC	D	—		500		ns
12	Diff Skew $t_{p1ha-t_{p1hl}}$ or $t_{p1hb-t_{p1hl}}$	T_{SKEW}	CC	D	—			0.5	ns
Termination									
13	Trans. Line (differential Z_0)		CC	D	—	95	100	105	Ω
14	Temperature		CC	D		-40		150	$^{\circ}\text{C}$

3.10 Oscillator and PLLRFM electrical characteristics

Table 26. PLLRFM electrical specifications

($V_{DDPLL} = 1.08\text{ V to }3.6\text{ V}$, $V_{SS} = V_{SSPLL} = 0\text{ V}$, $T_A = T_L\text{ to }T_H$)

Symbol	C	Parameter	Conditions	Value		Unit		
				min	max			
$f_{ref_crystal}$ f_{ref_ext}	CC	D	PLL reference frequency range ¹	Crystal reference	4	40	MHz	
				External reference	4	80		
f_{pll_in}	CC	P	Phase detector input frequency range (after pre-divider)	—	4	16	MHz	
f_{vco}	CC	P	VCO frequency range	—	256	512	MHz	
f_{sys}	CC	C	On-chip PLL frequency ²	—	16	150	MHz	
f_{sys}	CC	T	System frequency in bypass mode ²	Crystal reference	4	40	MHz	
		P		External reference	0	80		
t_{CYC}	CC	D	System clock period	—	—	$1 / f_{sys}$	ns	
f_{LORL} f_{LORH}	CC	D	Loss of reference frequency window ³	Lower limit	1.6	3.7	MHz	
		D		Upper limit	24	56		
f_{SCM}	CC	P	Self-clocked mode frequency ^{4,5}	—	1.2	72.25	MHz	
C_{JITTER}	CC	T	CLKOUT period jitter ^{6,7,8,9}	Peak-to-peak (clock edge to clock edge)	f_{SYS} maximum	-5	5	$\% f_{CLKOUT}$
		T				Long-term jitter (avg. over 2 ms interval)	-6	6
t_{cst}	CC	T	Crystal start-up time ^{10, 11}	—	—	10	ms	

Table 26. PLLMRFM electrical specifications
($V_{DDPLL} = 1.08\text{ V to }3.6\text{ V}$, $V_{SS} = V_{SSPLL} = 0\text{ V}$, $T_A = T_L\text{ to }T_H$) (continued)

Symbol		C	Parameter	Conditions	Value		Unit
					min	max	
V_{IHEXT}	CC	T	EXTAL input high voltage	Crystal Mode ¹²	$V_{xtal} + 0.4$	—	V
		T		External Reference ^{12, 13}	$V_{RC33}/2 + 0.4$	V_{RC33}	
V_{ILEXT}	CC	T	EXTAL input low voltage	Crystal Mode ¹²	—	$V_{xtal} - 0.4$	V
		T		External Reference ^{12, 13}	0	$V_{RC33}/2 - 0.4$	
—	CC	T	XTAL load capacitance ¹⁰	4 MHz	5	30	pF
				8 MHz	5	26	
				12 MHz	5	23	
				16 MHz	5	19	
				20 MHz	5	16	
				40 MHz	5	8	
t_{pLL}	CC	P	PLL lock time ^{10, 14}	—	—	200	μs
t_{dc}	CC	T	Duty cycle of reference	—	40	60	%
f_{LCK}	CC	T	Frequency LOCK range	—	-6	6	% f_{sys}
f_{UL}	CC	T	Frequency un-LOCK range	—	-18	18	% f_{sys}
f_{CS} f_{DS}	CC	D	Modulation Depth	Center spread	± 0.25	± 4.0	% f_{sys}
		D		Down Spread	-0.5	-8.0	
f_{MOD}	CC	D	Modulation frequency ¹⁵	—	—	100	kHz

¹ Considering operation with PLL not bypassed.

² All internal registers retain data at 0 Hz.

³ "Loss of Reference Frequency" window is the reference frequency range outside of which the PLL is in self clocked mode.

⁴ Self clocked mode frequency is the frequency that the PLL operates at when the reference frequency falls outside the f_{LOR} window.

⁵ f_{VCO} self clock range is 20–150 MHz. f_{SCM} represents f_{sys} after PLL output divider (ERFD) of 2 through 16 in enhanced mode.

⁶ This value is determined by the crystal manufacturer and board design.

⁷ Jitter is the average deviation from the programmed frequency measured over the specified interval at maximum f_{sys} . Measurements are made with the device powered by filtered supplies and clocked by a stable external clock signal. Noise injected into the PLL circuitry via V_{DDPLL} and V_{SSPLL} and variation in crystal oscillator frequency increase the C_{JITTER} percentage for a given interval.

- ⁸ Proper PC board layout procedures must be followed to achieve specifications.
- ⁹ Values are with frequency modulation disabled. If frequency modulation is enabled, jitter is the sum of C_{JITTER} and either f_{CS} or f_{DS} (depending on whether center spread or down spread modulation is enabled).
- ¹⁰ This value is determined by the crystal manufacturer and board design. For 4 MHz to 40 MHz crystals specified for this PLL, load capacitors should not exceed these limits.
- ¹¹ Proper PC board layout procedures must be followed to achieve specifications.
- ¹² This parameter is guaranteed by design rather than 100% tested.
- ¹³ V_{IHEXT} cannot exceed V_{RC33} in external reference mode.
- ¹⁴ This specification applies to the period required for the PLL to relock after changing the MFD frequency control bits in the synthesizer control register (SYNCR).
- ¹⁵ Modulation depth will be attenuated from depth setting when operating at modulation frequencies above 50 kHz.

3.11 Temperature sensor electrical characteristics

Table 27. Temperature sensor electrical characteristics

Symbol		C	Parameter	Conditions	Value			Unit
					min	typical	max	
—	CC	C	Temperature monitoring range		-40	—	150	°C
—	CC	C	Sensitivity		—	6.3	—	mV/°C
—	CC	P	Accuracy	$T_J = -40$ to 150 °C	-10	—	10	°C

3.12 eQADC electrical characteristics

Table 28. eQADC conversion specifications (operating)

Symbol		C	Parameter	Value		Unit
				min	max	
f_{ADCLK}	SR	—	ADC clock (ADCLK) frequency	2	16	MHz
CC	CC	D	Conversion cycles	2+13	128+14	ADCLK cycles
T_{SR}	CC	C	Stop mode recovery time ¹	—	10	μs
f_{ADCLK}	SR	—	ADC clock (ADCLK) frequency	2	16	mV

¹ Stop mode recovery time is the time from the setting of either of the enable bits in the ADC Control Register to the time that the ADC is ready to perform conversions. Delay from power up to full accuracy = 8 ms.

Table 29. eQADC single ended conversion specifications (operating)

Symbol		C	Parameter	Value		Unit
				min	max	
OFFNC	CC	C	Offset error without calibration	0	160	Counts
OFFWC	CC	C	Offset error with calibration	-4	4	Counts
GAINNC	CC	C	Full scale gain error without calibration	-160	0	Counts
GAINWC	CC	C	Full scale gain error with calibration	-4	4	Counts
I _{INJ}	CC	T	Disruptive input injection current ^{1, 2, 3, 4}	-3	3	mA
E _{INJ}	CC	T	Incremental error due to injection current ^{5,6}	-4	4	Counts
TUE8	CC	C	Total unadjusted error (TUE) at 8 MHz	-4	4 ⁶	Counts
TUE16	CC	C	Total unadjusted error at 16 MHz	-8	8	Counts

¹ Below disruptive current conditions, the channel being stressed has conversion values of 0x3FF for analog inputs greater than V_{RH} and 0x0 for values less than V_{RL} . Other channels are not affected by non-disruptive conditions.

² Exceeding limit may cause conversion error on stressed channels and on unstressed channels. Transitions within the limit do not affect device reliability or cause permanent damage.

³ Input must be current limited to the value specified. To determine the value of the required current-limiting resistor, calculate resistance values using $V_{POSCLAMP} = V_{DDA} + 0.5\text{ V}$ and $V_{NEGCLAMP} = -0.3\text{ V}$, then use the larger of the calculated values.

⁴ Condition applies to two adjacent pins at injection limits.

⁵ Performance expected with production silicon.

⁶ All channels have same $10\text{ k}\Omega < R_s < 100\text{ k}\Omega$; Channel under test has $R_s = 10\text{ k}\Omega$; $I_{INJ} = I_{INJMAX}, I_{INJMIN}$

Table 30. eQADC differential ended conversion specifications (operating)

Symbol		C	Parameter		Value		Unit
					min	max	
GAINVGA1 ¹	CC	-	Variable gain amplifier accuracy (gain=1) ²				
	CC	C	INL	8 MHz ADC	-4	4	Counts ₃
	CC	C		16 MHz ADC	-8	8	Counts
	CC	C	DNL	8 MHz ADC	-3 ⁴	3 ⁴	Counts
	CC	C		16 MHz ADC	-3 ⁴	3 ⁴	Counts

Table 30. eQADC differential ended conversion specifications (operating) (continued)

Symbol	C	Parameter	Value		Unit		
			min	max			
GAINVGA2 ¹	CC	–	Variable gain amplifier accuracy (gain=2) ²				
	CC	D	INL	8 MHz ADC	–5	5	Counts
	CC	D		16 MHz ADC	–8	8	Counts
	CC	D	DNL	8 MHz ADC	–3	3	Counts
	CC	D		16 MHz ADC	–3	3	Counts
GAINVGA4 ¹	CC	–	Variable gain amplifier accuracy (gain=4) ²				
	CC	D	INL	8 MHz ADC	–7	7	Counts
	CC	D		16 MHz ADC	–8	8	Counts
	CC	D	DNL	8 MHz ADC	–4	4	Counts
	CC	D		16 MHz ADC	–4	4	Counts
DIFF _{max}	CC	C	Maximum differential voltage (DANx+ - DANx-) or (DANx- - DANx+) ⁵	PREGAIN set to 1X setting	—	(VRH - VRL)/2	V
DIFF _{max2}	CC	C		PREGAIN set to 2X setting	—	(VRH - VRL)/4	V
DIFF _{max4}	CC	C		PREGAIN set to 4X setting	—	(VRH - VRL)/8	V
DIFF _{cmv}	CC	C	Differential input Common mode voltage (DANx- + DANx+)/2 ⁵	—	(VRH + VRL)/2 - 5%	(VRH + VRL)/2 + 5%	V

¹ Applies only to differential channels.

² Variable gain is controlled by setting the PRE_GAIN bits in the ADC_ACR1-8 registers to select a gain factor of ×1, ×2, or ×4. Settings are for differential input only. Tested at ×1 gain. Values for other settings are guaranteed by as indicated.

³ At $V_{RH} - V_{RL} = 5.12$ V, one LSB = 1.25 mV.

⁴ Guaranteed 10-bit mono tonicity.

⁵ Voltages between VRL and VRH will not cause damage to the pins. However, they may not be converted accurately if the differential voltage is above the maximum differential voltage. In addition, conversion errors may occur if the common mode voltage of the differential signal violates the Differential Input common mode voltage specification.

3.13 Configuring SRAM wait states

Use the SWSC field in the ECSM_MUDCR register to specify an additional wait state for the device SRAM. By default, no wait state is added.

Table 31. Cutoff frequency for additional SRAM wait state

1	SWSC Value
98	0
153	1

¹ Max frequencies including 2% PLL FM.

Please see the device reference manual for details.

3.14 Platform flash controller electrical characteristics

Table 32. APC, RWSC, WWSC settings vs. frequency of operation^{1,2}

Max. Flash Operating Frequency (MHz) ³	APC ⁴	RWSC ⁴	WWSC
20 MHz	0b000	0b000	0b11
61 MHz	0b001	0b001	0b11
90 MHz	0b010	0b010	0b11
123 MHz	0b011	0b011	0b11
153 MHz	0b100	0b100	0b11

¹ APC, RWSC and WWSC are fields in the flash memory BIUCR register used to specify wait states for address pipelining and read/write accesses. Illegal combinations exist—all entries must be taken from the same row.

² TBD: To Be Defined.

³ Max frequencies including 2% PLL FM.

⁴ APC must be equal to RWSC.

3.15 Flash memory electrical characteristics

Table 33. Flash program and erase specifications¹

#	Symbol	C	Parameter	Min. Value	Typical Value	Initial Max ²	Max ³	Unit	
1	T _{dwprogram}	CC	P	Double Word (64 bits) Program Time	—	38	—	500	μs
2	T _{pprogram}	CC	P	Page Program Time	—	45	160 ⁴	500	μs
3	T _{16kpperase}	CC	P	16 KB Block Pre-program and Erase Time	—	270	1000	5000	ms
5	T _{64kpperase}	CC	P	64 KB Block Pre-program and Erase Time	—	800	1800	5000	ms

Table 33. Flash program and erase specifications¹

#	Symbol	C	Parameter	Min. Value	Typical Value	Initial Max ²	Max ³	Unit	
6	T _{128kpperase}	CC	P	128 KB Block Pre-program and Erase Time	—	1500	2600	7500	ms
7	T _{256kpperase}	CC	P	256 KB Block Pre-program and Erase Time	—	3000	5200	15000	ms
8	T _{psrt}	SR	—	Program suspend request rate ⁵	100	—	—	—	μs
9	T _{esrt}	SR	—	Erase suspend request rate ⁶	10	—	—	—	ms

¹ Typical program and erase times assume nominal supply values and operation at 25 °C. All times are subject to change pending device characterization.

² Initial factory condition: ≤ 100 program/erase cycles, 25 °C, typical supply voltage, 80 MHz minimum system frequency.

³ The maximum erase time occurs after the specified number of program/erase cycles. This maximum value is characterized but not guaranteed.

⁴ Page size is 128 bits (4 words).

⁵ Time between program suspend resume and the next program suspend request.

⁶ Time between erase suspend resume and the next erase suspend request.

Table 34. Flash module life

Symbol	C	Parameter	Conditions	Value		Unit	
				min	typ		
P/E	CC	C	Number of program/erase cycles per block for 16 KB, 48 KB, and 64 Kbyte blocks over the operating temperature range (T _J)	—	100,000	—	P/E cycles
P/E	CC	C	Number of program/erase cycles per block for 128 Kbyte and 256 Kbyte blocks over the operating temperature range (T _J)	—	1,000	100,000	P/E cycles
Data Retention	CC	C	Minimum data retention at 85 °C average ambient temperature ¹	Blocks with 0 – 1,000 P/E cycles	20	—	years
				Blocks with 1,001 – 10,000 P/E cycles	10	—	years
				Blocks with 10,001 – 100,000 P/E cycles	5	—	years

¹ Ambient temperature averaged over duration of application, not to exceed product operating temperature range.

3.16 AC specifications

3.16.1 Pad AC specifications

Table 35. Pad AC specifications (5.0 V)¹

Name	C	D	Output Delay (ns) ^{2,3} Low-to-High / High-to-Low		Rise/Fall Edge (ns) ^{3,4}		Drive Load (pF)	SRC/DSC
			Min	Max	Min	Max		MSB,LSB
Medium ^{5,6,7}	CC	D	4.6/3.7	12/12	2.2/2.2	7/7	50	11 ⁸
	N/A							10 ⁹
	CC	D	12/13	28/34	5.6/6	15/15	50	01
	CC	D	69/71	152/165	34/35	74/74	50	00
Slow ^{7,10}	CC	D	7.3/5.7	19/18	4.4/4.3	14/14	50	11 ⁸
	N/A							10 ⁹
	CC	D	26/27	61/69	13/13	34/34	50	01
	CC	D	137/142	320/330	72/74	164/164	50	00
MultiV ¹¹ (High Swing Mode)	CC	D	4.1/3.6	10.3/8.9	3.28/2.98	8/8	50	11 ⁸
	N/A							10 ⁹
	CC	D	8.38/6.11	16/12.9	5.48/4.81	11/11	50	01
	CC	D	61.7/10.4	92.2/24.3	42.0/12.2	63/63	50	00
MultiV (Low Swing Mode)	CC	D	2.31/2.34	7.62/6.33	1.26/1.67	6.5/4.4	30	11 ⁸
Fast ¹²	N/A							
pad_i_hv ¹³	CC	D	0.5/0.5	1.9/1.9	0.3/0.3	±1.5/1.5	0.5	N/A
pull_hv	CC	D	NA	6000		5000/5000	50	N/A

¹ These are worst case values that are estimated from simulation and not tested. The values in the table are simulated at $V_{DD} = 1.14\text{ V to }1.32\text{ V}$, $V_{DDEH} = 4.5\text{ V to }5.5\text{ V}$, $T_A = T_L\text{ to }T_H$

² This parameter is supplied for reference and is not guaranteed by design and not tested.

³ Delay and rise/fall are measured to 20% or 80% of the respective signal.

⁴ This parameter is guaranteed by characterization before qualification rather than 100% tested.

⁵ In high swing mode, high/low swing pad V_{ol} and V_{oh} values are the same as those of the slew controlled output pads

⁶ Medium Slew-Rate Controlled Output buffer. Contains an input buffer and weak pullup/pulldown.

⁷ Output delay is shown in Figure 9. Add a maximum of one system clock to the output delay for delay with respect to system clock.

⁸ Can be used on the tester.

⁹ This drive select value is not supported. If selected, it will be approximately equal to 11.

¹⁰ Slow Slew-Rate Controlled Output buffer. Contains an input buffer and weak pullup/pulldown.

¹¹ Selectable high/low swing IO pad with selectable slew in high swing mode only.

¹² Fast pads are 3.3 V pads.

¹³ Stand alone input buffer. Also has weak pull-up/pull-down.

Table 36. Pad AC specifications ($V_{DDE} = 3.3\text{ V}$)¹

Pad Type	C	D	Output Delay (ns) ^{2,3} Low-to-High / High-to-Low		Rise/Fall Edge (ns) ^{3,4}		Drive Load (pF)	SRC/DSC
			Min	Max	Min	Max		MSB,LSB
Medium ^{5,6,7}	CC	D	5.8/4.4	18/17	2.7/2.1	10/10	50	11 ⁸
	CC	D	16/13	46/49	11.2/8.6	34/34	200	
	N/A							10 ⁹
	CC	D	14/16	37/45	6.5/6.7	19/19	50	01
	CC	D	27/27	69/82	15/13	43/43	200	
	CC	D	83/86	200/210	38/38	86/86	50	00
	CC	D	113/109	270/285	53/46	120/120	200	
Slow ^{7,10}	CC	D	9.2/6.9	27/28	5.5/4.1	20/20	50	11
	CC	D	30/23	81/87	21/16	63/63	200	
	N/A							10 ⁹
	CC	D	31/31	80/90	15.4/15.4	42/42	50	01
	CC	D	58/52	144/155	32/26	82/85	200	
	CC	D	162/168	415/415	80/82	190/190	50	00
	CC	D	216/205	533/540	106/95	250/250	200	
MultiV ^{7,11} (High Swing Mode)	CC	D		3.7/3.1		10/10	30	11 ⁸
	CC	D		46/49		37/37	200	
	N/A							10 ⁹
	CC	D		32		15/15	50	01
	CC	D		72		46/46	200	
	CC	D		210		100/100	50	00
	CC	D		295		134/134	200	
MultiV (Low Swing Mode)	Not a valid operational mode							
Fast	CC	D		2.5/2.5		1.2/1.2	10	00
	CC	D		2.5/2.5		1.2/1.2	20	01
	CC	D		2.5/2.5		1.2/1.2	30	10
	CC	D		2.5/2.5		1.2/1.2	50	11 ⁸
pad_i_hv ¹²	CC	D	0.5/0.5	3/3	0.4/0.4	±1.5/1.5	0.5	N/A
pull_hv	CC	D	NA	6000		5000/5000	50	N/A

¹ These are worst case values that are estimated from simulation and not tested. The values in the table are simulated at $V_{DD} = 1.14\text{ V}$ to 1.32 V , $V_{DDE} = 3\text{ V}$ to 3.6 V , $V_{DDEH} = 3\text{ V}$ to 3.6 V , $T_A = T_L$ to T_H .

- 2 This parameter is supplied for reference and is not guaranteed by design and not tested.
- 3 Delay and rise/fall are measured to 20% or 80% of the respective signal.
- 4 This parameter is guaranteed by characterization before qualification rather than 100% tested.
- 5 In high swing mode, high/low swing pad V_{OL} and V_{OH} values are the same as those of the slew controlled output pads
- 6 Medium Slew-Rate Controlled Output buffer. Contains an input buffer and weak pullup/pulldown.
- 7 Output delay is shown in [Figure 9](#). Add a maximum of one system clock to the output delay for delay with respect to system clock.
- 8 Can be used on the tester.
- 9 This drive select value is not supported. If selected, it will be approximately equal to 11.
- 10 Slow Slew-Rate Controlled Output buffer. Contains an input buffer and weak pullup/pulldown.
- 11 Selectable high/low swing IO pad with selectable slew in high swing mode only.
- 12 Stand alone input buffer. Also has weak pull-up/pull-down.

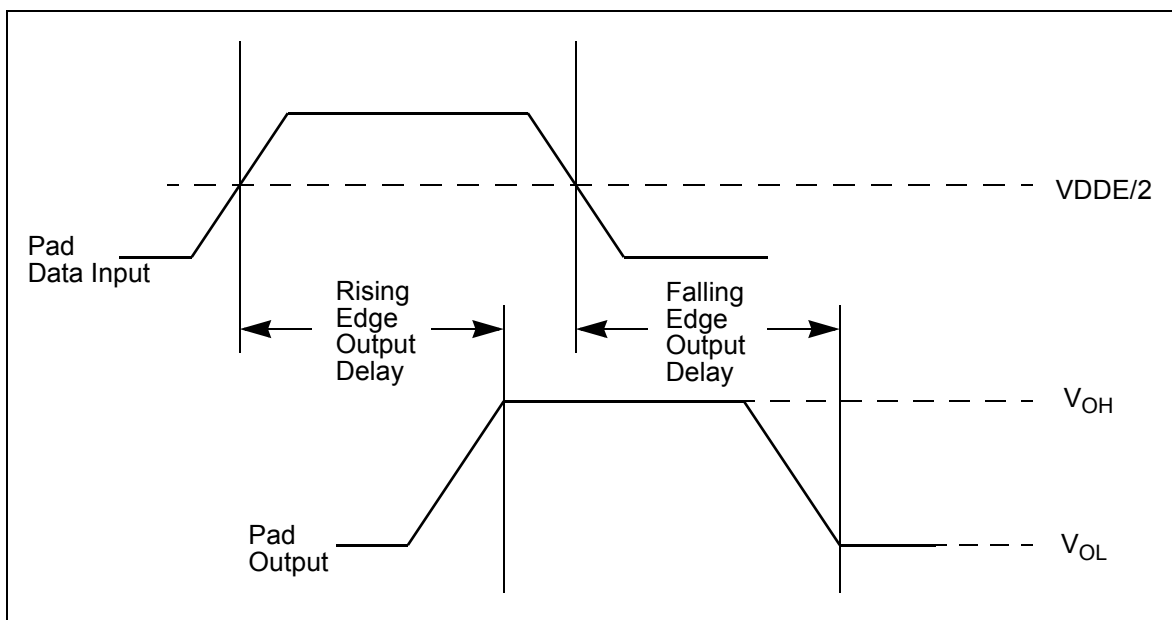

Figure 9. Pad output delay

3.17 AC timing

3.17.1 Reset and configuration pin timing

Table 37. Reset and Configuration Pin Timing¹

#	Characteristic	Symbol	Min	Max	Unit
1	$\overline{\text{RESET}}$ Pulse Width ²	t_{RPW}	10	—	t_{cyc}
2	$\overline{\text{RESET}}$ Glitch Detect Pulse Width	t_{GPW}	2	—	t_{cyc}
3	PLLREF, BOOTCFG, WKPCFG Setup Time to $\overline{\text{RSTOUT}}$ Valid	t_{RCSU}	10	—	t_{cyc}
4	PLLREF, BOOTCFG, WKPCFG Hold Time to $\overline{\text{RSTOUT}}$ Valid	t_{RCH}	0	—	t_{cyc}

¹ Reset timing specified at: $V_{\text{DDEH}} = 3.0 \text{ V to } 5.25 \text{ V}$, $V_{\text{DD}} = 1.14 \text{ V to } 1.32 \text{ V}$, $T_{\text{A}} = T_{\text{L}} \text{ to } T_{\text{H}}$.

² $\overline{\text{RESET}}$ pulse width is measured from 50% of the falling edge to 50% of the rising edge.

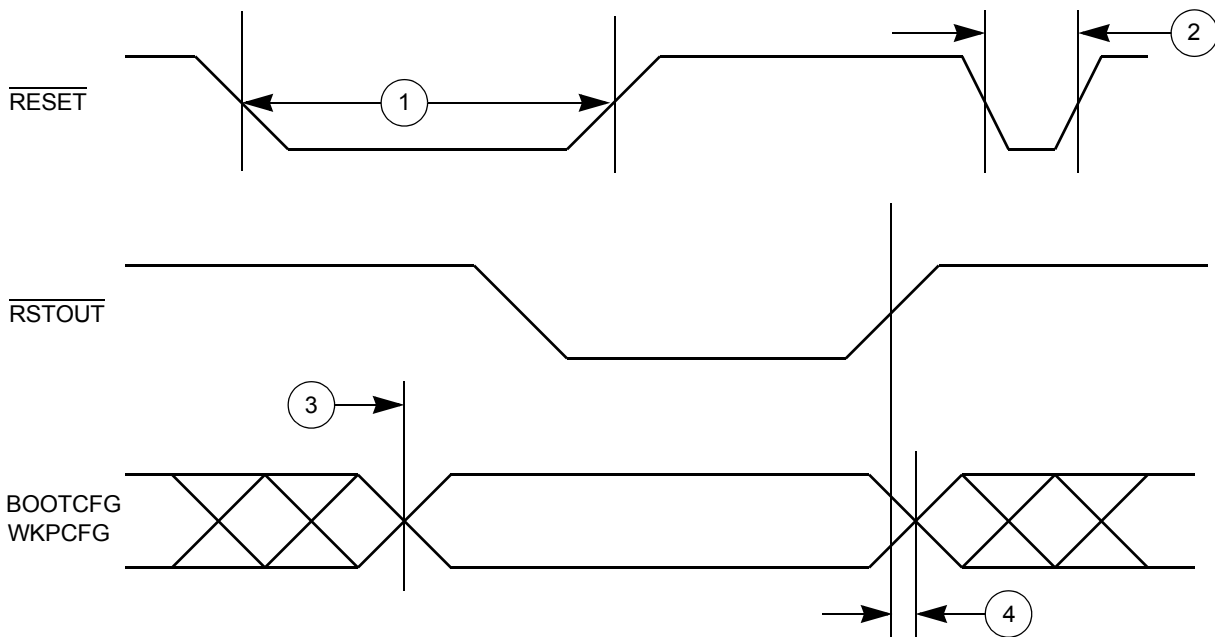

Figure 10. Reset and Configuration Pin Timing

3.17.2 IEEE 1149.1 interface timing

Table 38. JTAG pin AC electrical characteristics¹

#	Symbol	C	D	Characteristic	Min. Value	Max. Value	Unit
1	t _{JCYC}	CC	D	TCK Cycle Time	100	—	ns
2	t _{JDC}	CC	D	TCK Clock Pulse Width	40	60	ns
3	t _{TCKRISE}	CC	D	TCK Rise and Fall Times (40% - 70%)	—	3	ns
4	t _{TMSS} , t _{TDIS}	CC	D	TMS, TDI Data Setup Time	5	—	ns
5	t _{TMSH} , t _{TDIH}	CC	D	TMS, TDI Data Hold Time	25	—	ns
6	t _{TDOV}	CC	D	TCK Low to TDO Data Valid	—	22 ²	ns
7	t _{TDOI}	CC	D	TCK Low to TDO Data Invalid	0	—	ns
8	t _{TDOHZ}	CC	D	TCK Low to TDO High Impedance	—	22	ns
9	t _{JCMPPW}	CC	D	JCOMP Assertion Time	100	—	ns
10	t _{JCMPS}	CC	D	JCOMP Setup Time to TCK Low	40	—	ns
11	t _{BSDV}	CC	D	TCK Falling Edge to Output Valid	—	50	ns
12	t _{BSDVZ}	CC	D	TCK Falling Edge to Output Valid out of High Impedance	—	50	ns
13	t _{BSDHZ}	CC	D	TCK Falling Edge to Output High Impedance	—	50	ns
14	t _{BSDST}	CC	D	Boundary Scan Input Valid to TCK Rising Edge	25 ³	—	ns
15	t _{BSDHT}	CC	D	TCK Rising Edge to Boundary Scan Input Invalid	25 ³	—	ns

¹ JTAG timing specified at V_{DD} = 1.14 V to 1.32 V, V_{DDEH} = 4.5 V to 5.5 V with multi-voltage pads programmed to Low-Swing mode, T_A = T_L to T_H, and C_L = 30 pF with DSC = 0b10, SRC = 0b11. These specifications apply to JTAG boundary scan only. See Table 39 for functional specifications.

² Pad delay is 8–10 ns. Remainder includes TCK pad delay, clock tree delay logic delay and TDO output pad delay.

³ For 20 MHz TCK.

NOTE

The Nexus/JTAG Read/Write Access Control/Status Register (RWCS) write (to begin a read access) or the write to the Read/Write Access Data Register (RWD) (to begin a write access) does not actually begin its action until 1 JTAG clock (TCK) after leaving the JTAG Update-DR state. This prevents the access from being performed and therefore will not signal its completion via the READY (RDY) output unless the JTAG controller receives an additional TCK. In addition, EVTI is not latched into the device unless there are clock transitions on TCK.

The tool/debugger must provide at least one TCK clock for the EVTI signal to be recognized by the MCU. When using the RDY signal to indicate the end of a Nexus read/write access, ensure that TCK continues to run for at least 1 TCK after leaving the Update-DR state. This can be just a TCK with TMS low while in the Run-Test/Idle state or by continuing with the next Nexus/JTAG command. Expect the affect of EVTI and RDY to be delayed by edges of TCK. Note: RDY is not available in all packages of all devices.

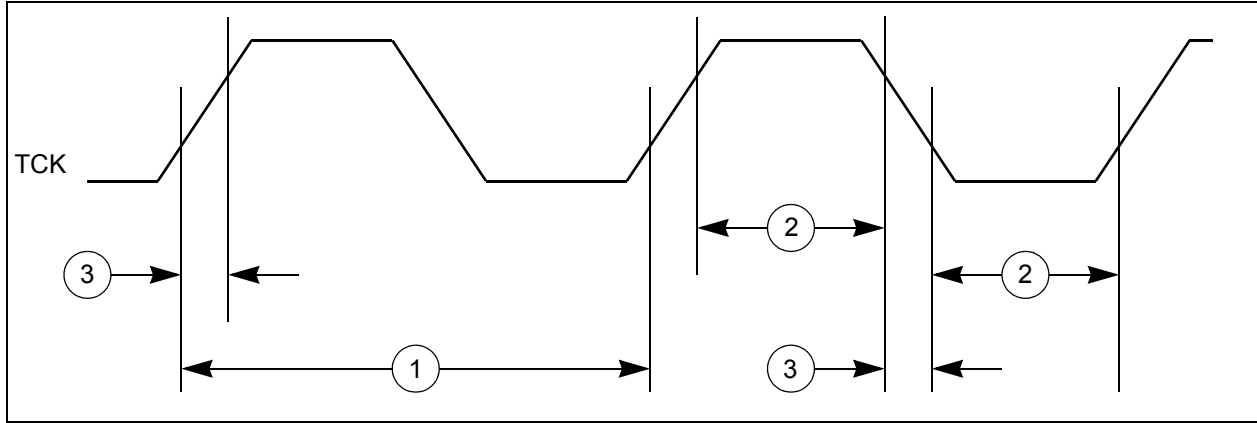

Figure 11. JTAG test clock input timing

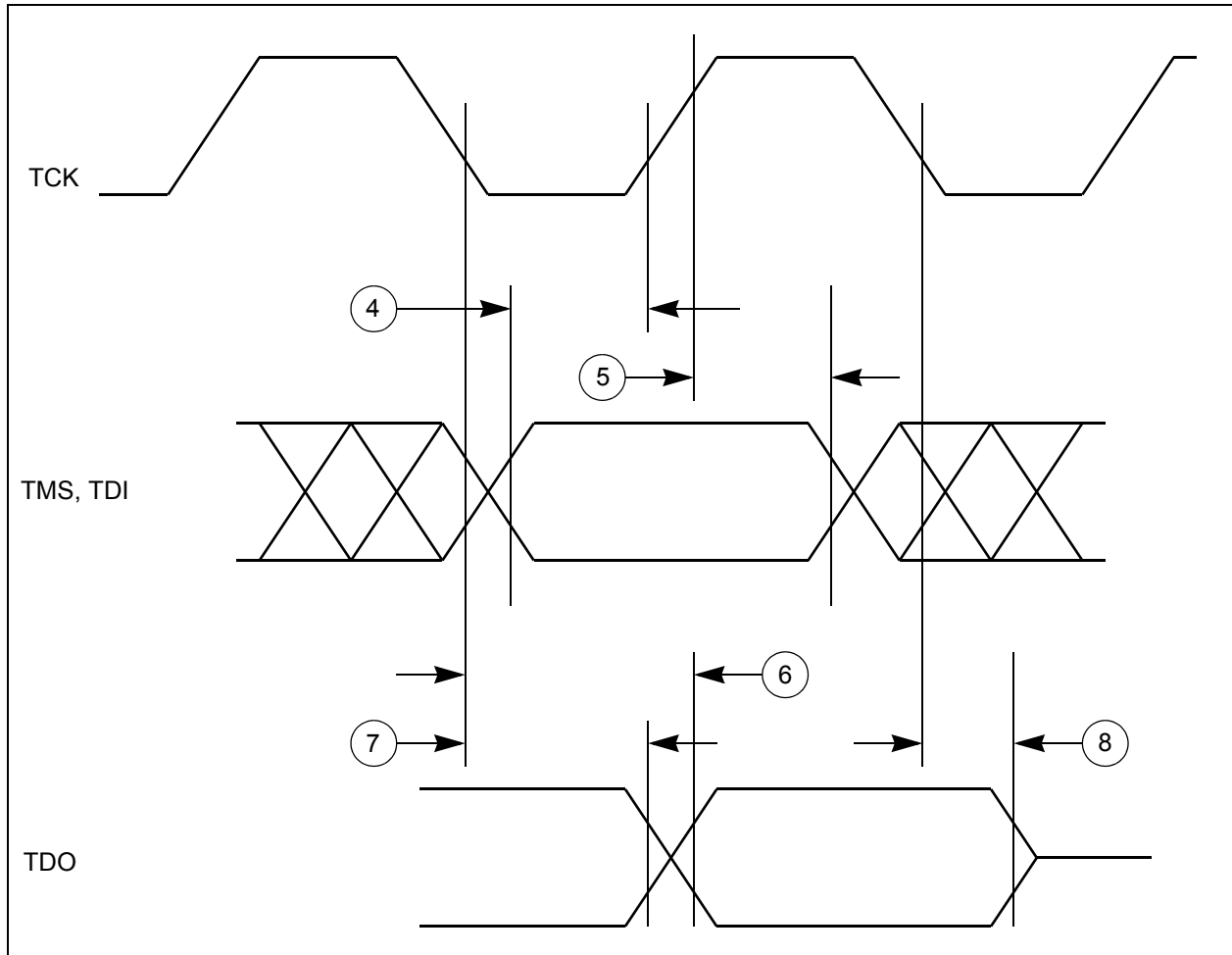

Figure 12. JTAG test access port timing

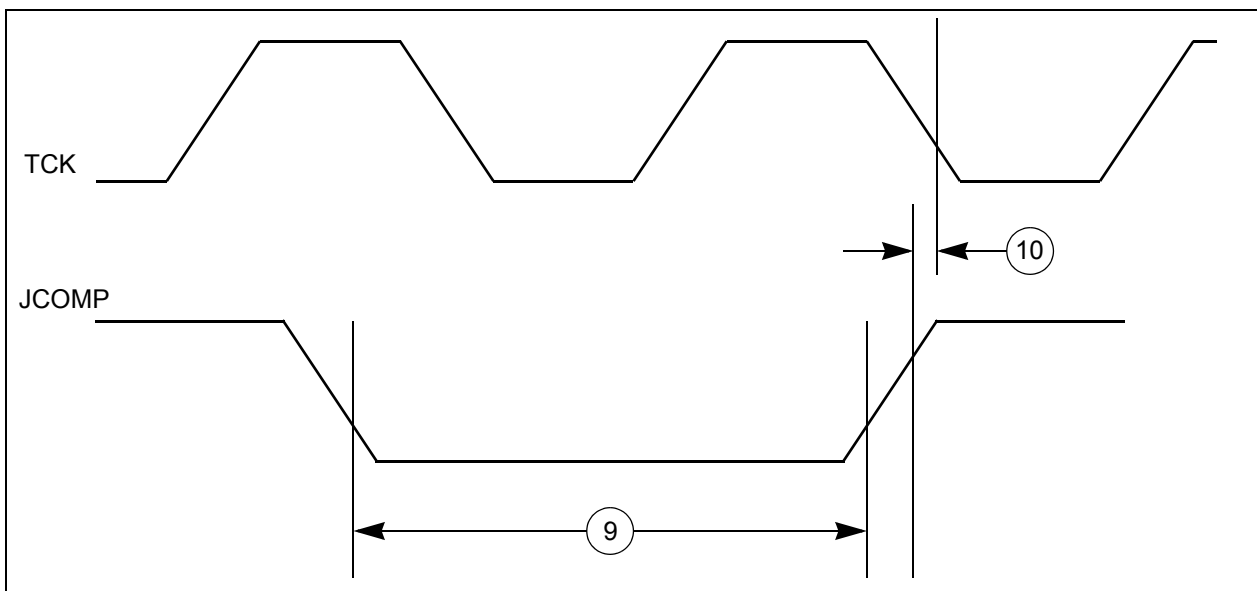

Figure 13. JTAG JCOMP timing

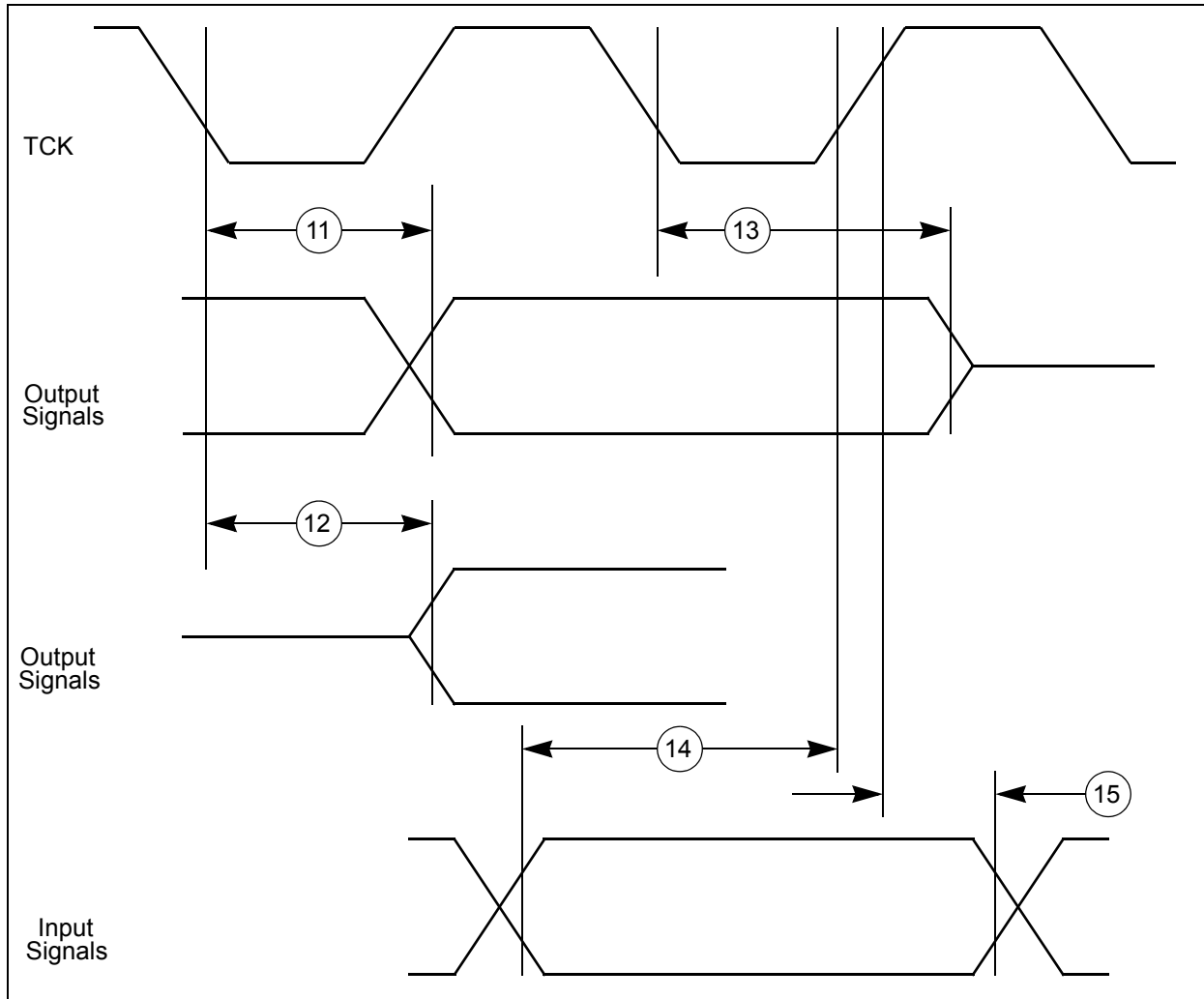

Figure 14. JTAG boundary scan timing

3.17.3 Nexus timing

Table 39. Nexus debug port timing¹

#	Symbol	C	D	Characteristic	Min. Value	Max. Value	Unit
1	t_{MCYC}	CC	D	MCKO Cycle Time	2 ^{2,3}	8	t_{CYC}
1a	t_{MCYC}	CC	D	Absolute Minimum MCKO Cycle Time	25 ⁴	—	ns
2	t_{MDC}	CC	D	MCKO Duty Cycle	40	60	%
3	t_{MDOV}	CC	D	MCKO Low to MDO Data Valid ⁵	- 0.1	0.35	t_{MCYC}
4	t_{MSEOV}	CC	D	MCKO Low to MSEO Data Valid ⁵	- 0.1	0.35	t_{MCYC}
6	t_{EVTOV}	CC	D	MCKO Low to EVTO Data Valid ⁵	- 0.1	0.35	t_{MCYC}
7	t_{EVTIPW}	CC	D	EVTI Pulse Width	4.0	—	t_{TCYC}
8	t_{EVTOPW}	CC	D	EVTO Pulse Width	1	—	t_{MCYC}
9	t_{TCYC}	CC	D	TCK Cycle Time	4 ^{6,7}	—	t_{CYC}
9a	t_{TCYC}	CC	D	Absolute Minimum TCK Cycle Time	100 ⁸	—	ns
10	t_{TDC}	CC	D	TCK Duty Cycle	40	60	%

Table 39. Nexus debug port timing¹ (continued)

#	Symbol	C	Characteristic	Min. Value	Max. Value	Unit
11	t_{NTDIS}	CC	TDI Data Setup Time	5	—	ns
12	t_{NTDIH}	CC	TDI Data Hold Time	25	—	ns
13	t_{NTMSS}	CC	TMS Data Setup Time	5	—	ns
14	t_{NTMSH}	CC	TMS Data Hold Time	25	—	ns
15	—	CC	TDO propagation delay from falling edge of TCK	—	19.5	ns
16	—	CC	TDO hold time with respect to TCK falling edge (minimum TDO propagation delay)	5.25	—	ns

¹ All Nexus timing relative to MCKO is measured from 50% of MCKO and 50% of the respective signal. Nexus timing specified at $V_{DD} = 1.14\text{ V to }1.32\text{ V}$, $V_{DDEH} = 4.5\text{ V to }5.5\text{ V}$ with multi-voltage pads programmed to Low-Swing mode, $T_A = T_L$ to T_H , and $C_L = 30\text{ pF}$ with $DSC = 0b10$.

² Achieving the absolute minimum MCKO cycle time may require setting the MCKO divider to more than its minimum setting ($NPC_PCR[MCKO_DIV]$) depending on the actual system frequency being used.

³ This is a functionally allowable feature. However, this may be limited by the maximum frequency specified by the Absolute minimum MCKO period specification.

⁴ This may require setting the MCO divider to more than its minimum setting ($NPC_PCR[MCKO_DIV]$) depending on the actual system frequency being used.

⁵ \overline{MDO} , \overline{MSEO} , and \overline{EVTO} data is held valid until next MCKO low cycle.

⁶ Achieving the absolute minimum TCK cycle time may require a maximum clock speed (system frequency / 8) that is less than the maximum functional capability of the design (system frequency / 4) depending on the actual system frequency being used.

⁷ This is a functionally allowable feature. However, this may be limited by the maximum frequency specified by the Absolute minimum TCK period specification.

⁸ This may require a maximum clock speed (system frequency / 8) that is less than the maximum functional capability of the design (system frequency / 4) depending on the actual system frequency being used.

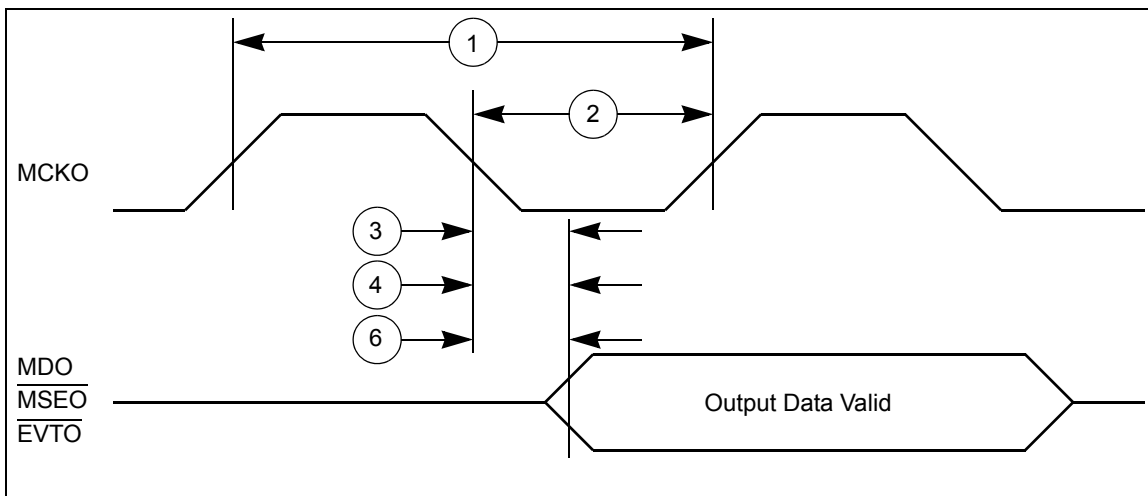

Figure 15. Nexus output timing

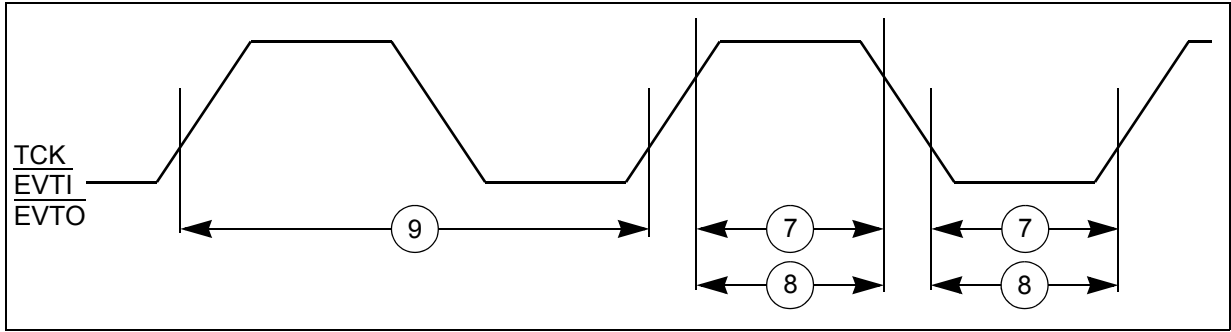

Figure 16. Nexus event trigger and test clock timings

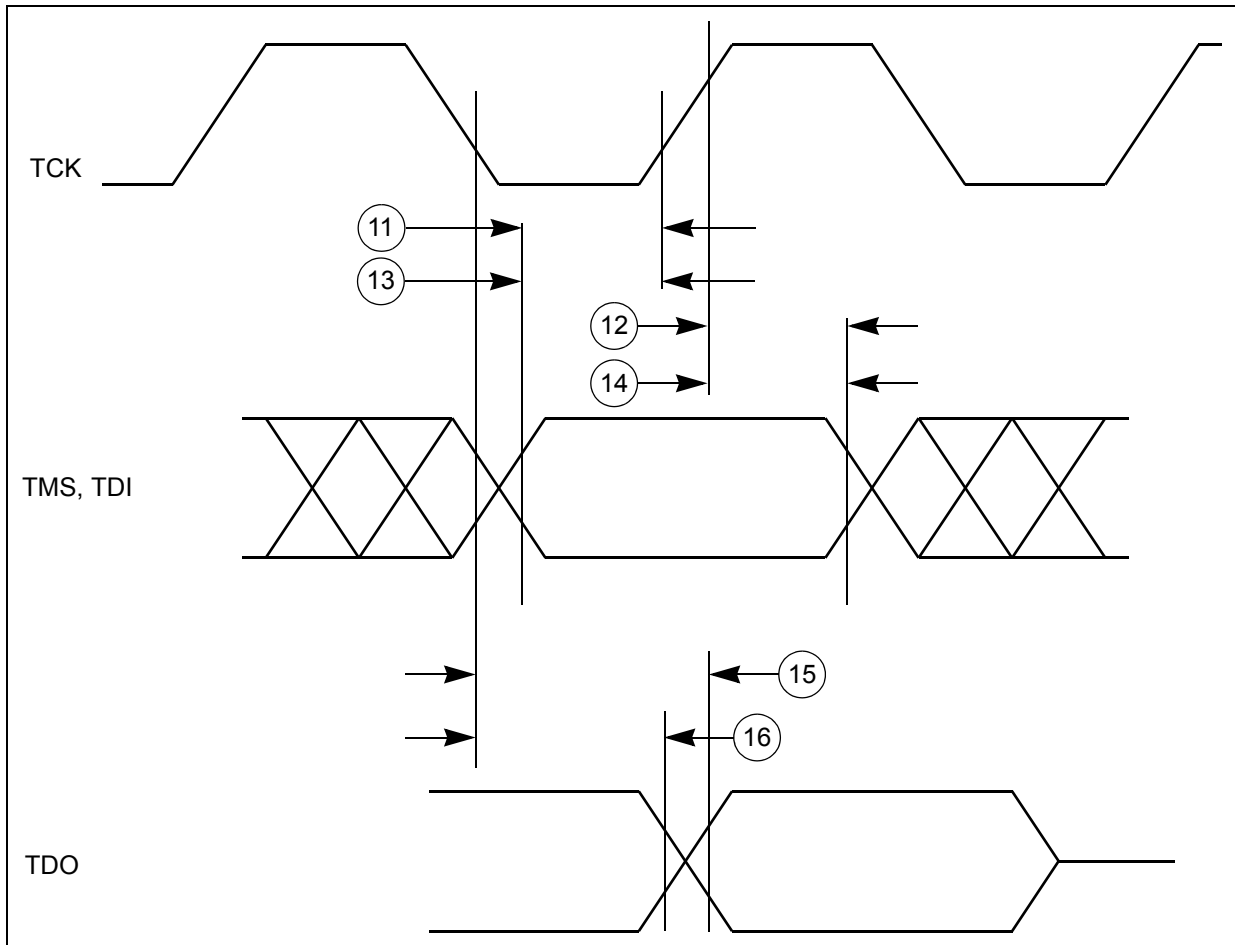

Figure 17. Nexus TDI, TMS, TDO timing

Table 40. Nexus debug port operating frequency

Package	Nexus Width	Nexus Routing	Nexus Pin Usage			Max. Operating Frequency
			MDO[0:3]	MDO[4:11]	CAL_MDO[4:11]	
176 LQFP 208 BGA 324 BGA	Reduced port mode ¹	Route to MDO ²	Nexus Data Out [0:3]	GPIO	GPIO	40 MHz ³
	Full port mode ⁴	Route to MDO ²	Nexus Data Out [0:3]	Nexus Data Out [4:11]	GPIO	40 MHz ^{5,6}
496 CSP	Reduced port mode ¹	Route to MDO ²	Nexus Data Out [0:3]	GPIO	GPIO	40 MHz ³
	Full port mode ⁴	Route to MDO ²	Nexus Data Out [0:3]	Nexus Data Out [4:11]	GPIO	40 MHz ^{5,6}
		Route to CAL_MDO ⁷	Cal Nexus Data Out [0:3]	GPIO	Cal Nexus Data Out [4:11]	40 MHz ³

¹ NPC_PCR[FPM] = 0

² NPC_PCR[NEXCFG] = 0

³ The Nexus AUX port runs up to 40 MHz. Set NPC_PCR[MCKO_DIV] to divide-by-two if the system frequency is greater than 40 MHz.

⁴ NPC_PCR[FPM] = 1

⁵ Set the NPC_PCR[MCKO_DIV] to divide by two if the system frequency is between 40 MHz and 80 MHz inclusive. Set the NPC_PCR[MCKO_DIV] to divide by four if the system frequency is greater than 80 MHz.

⁶ Pad restrictions limit the Maximum Operation Frequency in these configurations

⁷ NPC_PCR[NEXCFG] = 1

3.17.4 External Bus Interface (EBI) and calibration bus interface timing

Table 41. External Bus Interface maximum operating frequency

Port Width	Multiplexed Mode	ADDR[12:15] Pin Usage	ADDR[16:31] Pin Usage	DATA[0:15] Pin Usage	Max. Operating Frequency
16-bit	Yes	ADDR[12:15]	GPIO	ADDR[16:31] DATA[0:15]	66 MHz ¹
16-bit	No	ADDR[12:15]	ADDR[16:31]	DATA[0:15]	33 MHz ^{2,3}
32-bit	Yes	ADDR[12:15]	ADDR[16:31] DATA[16:31]	DATA[0:15]	33 MHz ^{2,3}

¹ Set SIU_ECCR[EBDF] to divide by two or divide by four if the system frequency is greater than 66 MHz.

² System Frequency must be ≤ 132 MHz and SIU_ECCR[EBDF] set to divide by four.

³ Pad restrictions limit the maximum operating frequency.

Table 42. Calibration bus interface maximum operating frequency

Port Width	Multiplexed Mode	CAL_ADDR[12:15] Pin Usage	CAL_ADDR[16:30] Pin Usage	CAL_DATA[0:15] Pin Usage	Max. Operating Frequency
16-bit	Yes	GPIO	GPIO	CAL_ADDR[12:30] CAL_DATA[0:15]	66 MHz ¹
16-bit	No	CAL_ADDR[12:15]	CAL_ADDR[16:30]	CAL_DATA[0:15]	66 MHz ¹
32-bit	Yes	CAL_WE[2:3] CAL_DATA[31]	CAL_ADDR[16:30] CAL_DATA[16:30]	CAL_ADDR[0:15] CAL_DATA[0:15]	66 MHz ¹

¹ Set SIU_ECCR[EBDF] to divide by two or divide by four if the system frequency is greater than 66 MHz

Table 43. External bus interface (EBI) and calibration bus operation timing ¹

#	Symbol	C	Characteristic	66 MHz (ext. bus) ²		Unit	Notes	
				Min	Max			
1	T _C	CC	P	CLKOUT Period	15.2	—	ns	Signals are measured at 50% V _{DDE} .
2	t _{CDC}	CC	D	CLKOUT duty cycle	45%	55%	T _C	
3	t _{CRT}	CC	D	CLKOUT rise time	—	3	ns	
4	t _{CFT}	CC	D	CLKOUT fall time	—	3	ns	
5	t _{COH}	CC	D	CLKOUT Posedge to Output Signal Invalid or High Z(Hold Time)	1.3	—	ns	
				<ul style="list-style-type: none"> • ADDR[8:31] • CS[0:3] • DATA[0:31] • OE • RD_{WR} • TS • WE[0:3]/BE[0:3] 				

Table 43. External bus interface (EBI) and calibration bus operation timing ¹ (continued)

#	Symbol	C	Characteristic	66 MHz (ext. bus) ²		Unit	Notes
				Min	Max		
6	t _{COV}	CC	D CLKOUT Posedge to Output Signal Valid (Output Delay) ADDR[8:31] CS[0:3] DATA[0:31] OE RD_W \overline{R} TS WE[0:3]/BE[0:3]	—	9	ns	
7	t _{CIS}	CC	D Input Signal Valid to CLKOUT Posedge (Setup Time) DATA[0:31]	6.0	—	ns	
8	t _{CIH}	CC	D CLKOUT Posedge to Input Signal Invalid (Hold Time) DATA[0:31]	1.0	—	ns	
9	t _{APW}	CC	D ALE Pulse Width ⁴	6.5	—	ns	
10	t _{AAI}	CC	D ALE Negated to Address Invalid ⁴	1.5 ⁵	—	ns	

¹ External Bus and Calibration bus timing specified at f_{SYS} = 150 MHz and 100 MHz, V_{DD} = 1.14 V to 1.32 V, V_{DDE} = 3 V to 3.6 V (unless stated otherwise), T_A = T_L to T_H, and C_L = 30 pF with DSC = 0b10.

² The external bus is limited to half the speed of the internal bus. The maximum external bus frequency is 66 MHz for 16-bit muxed mode and 33 MHz for non-muxed mode. For The EBI division factor should be set accordingly based on the internal frequency being used.

³ Refer to Fast Pad timing in Table 35 and Table 36 (different values for 1.8 V vs. 3.3 V).

⁴ Measured at 50% of ALE.

⁵ When CAL_TS pad is used for CAL_ALE function the hold time is 1 ns instead of 1.5 ns.

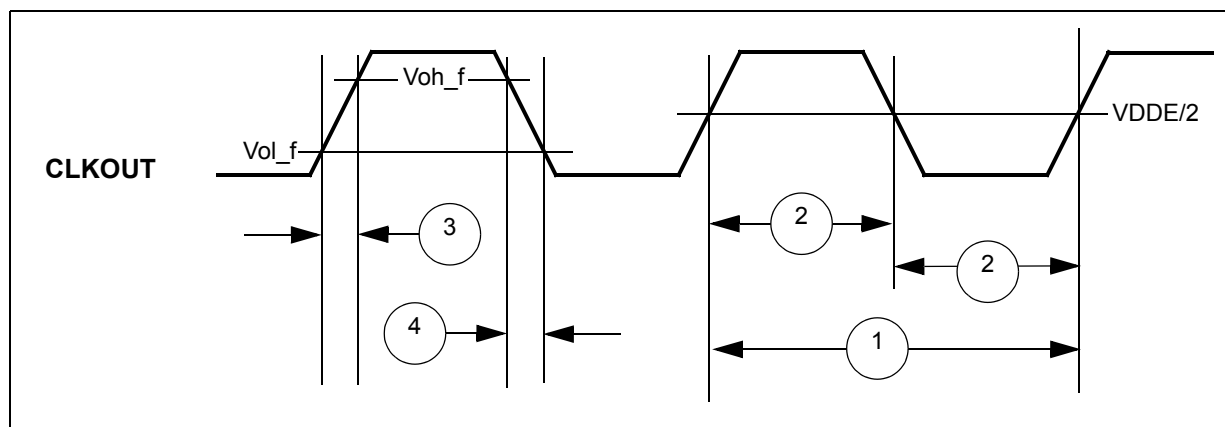

Figure 18. CLKOUT timing

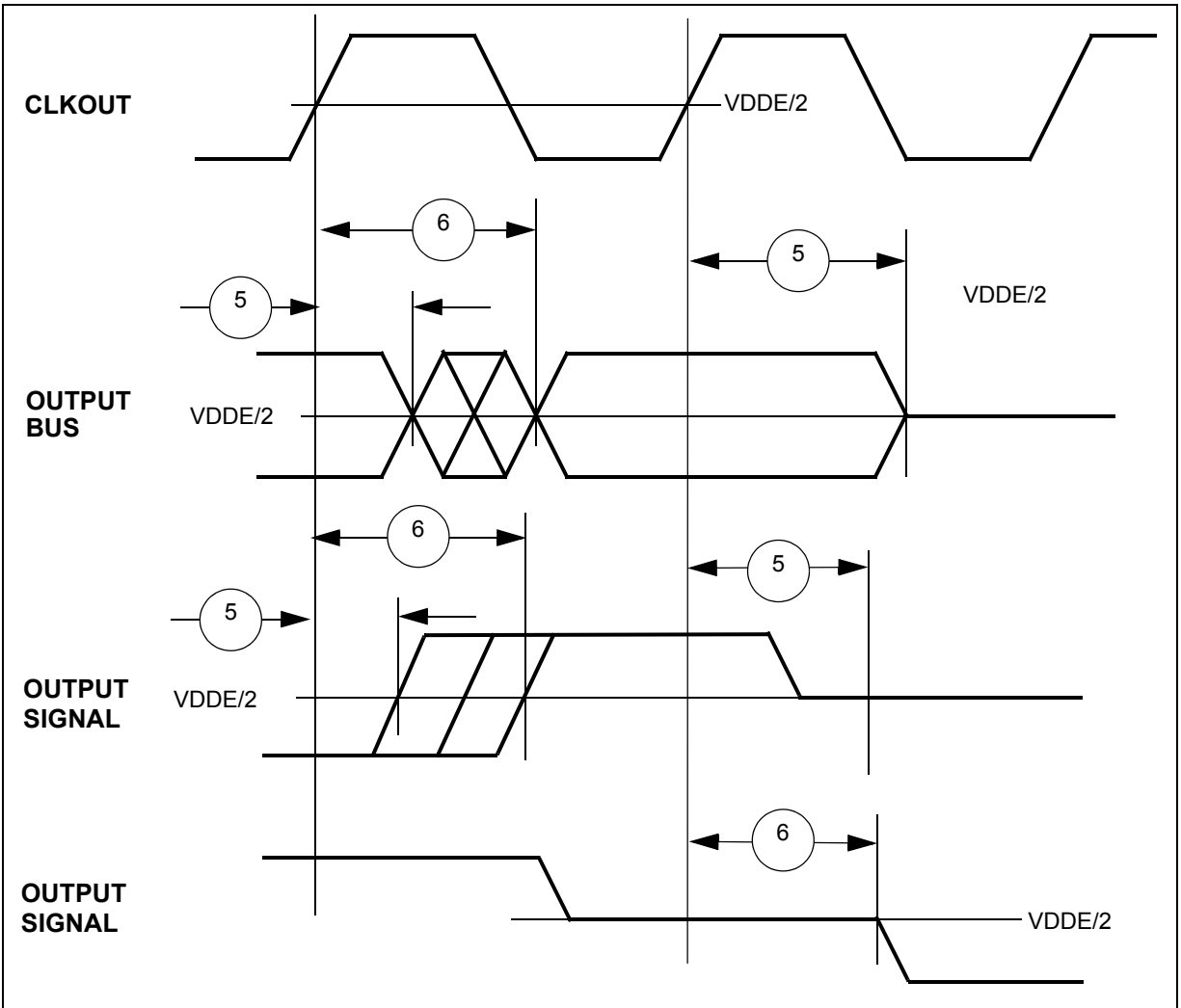

Figure 19. Synchronous output timing

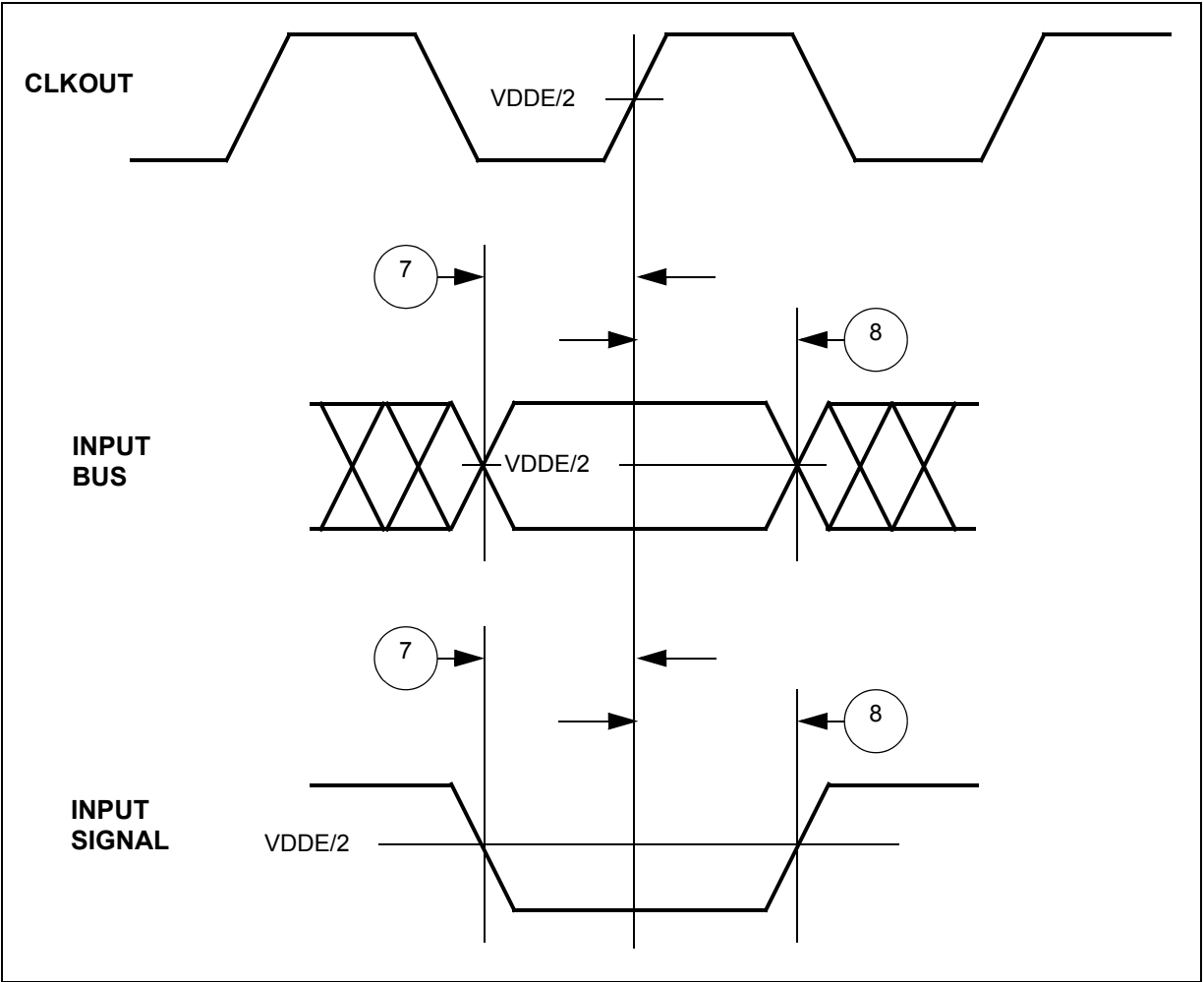

Figure 20. Synchronous input timing

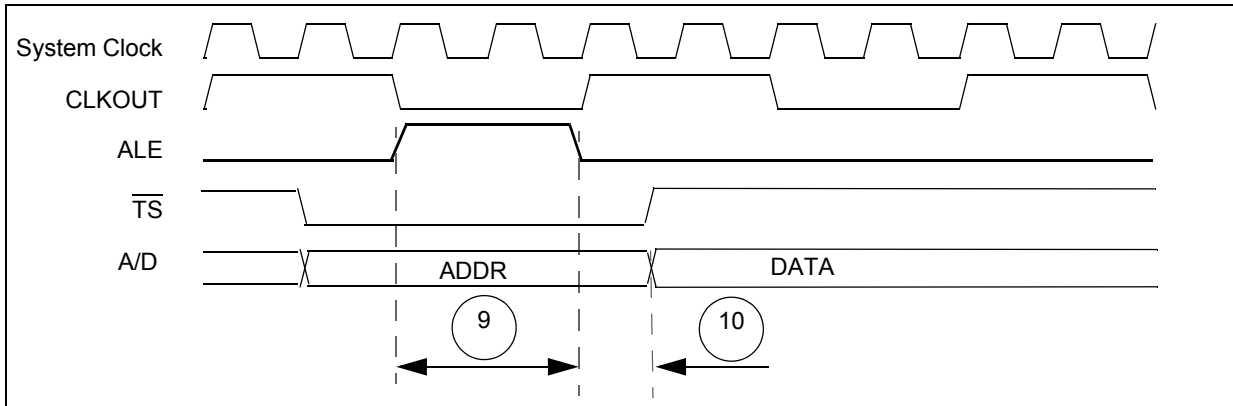

Figure 21. ALE signal timing

3.17.5 External interrupt timing (IRQ pin)

Table 44. External interrupt timing¹

#	Characteristic	Symbol	Min	Max	Unit
1	IRQ Pulse Width Low	t_{IPWL}	3	—	t_{cyc}
2	IRQ Pulse Width High	t_{IPWH}	3	—	t_{cyc}
3	IRQ Edge to Edge Time ²	t_{ICYC}	6	—	t_{cyc}

¹ IRQ timing specified at $V_{DD} = 1.14 \text{ V to } 1.32 \text{ V}$, $V_{DDEH} = 3.0 \text{ V to } 5.5 \text{ V}$, V_{DD33} and $V_{DDSYN} = 3.0 \text{ V to } 3.6 \text{ V}$, $T_A = T_L$ to T_H .

² Applies when IRQ pins are configured for rising edge or falling edge events, but not both.

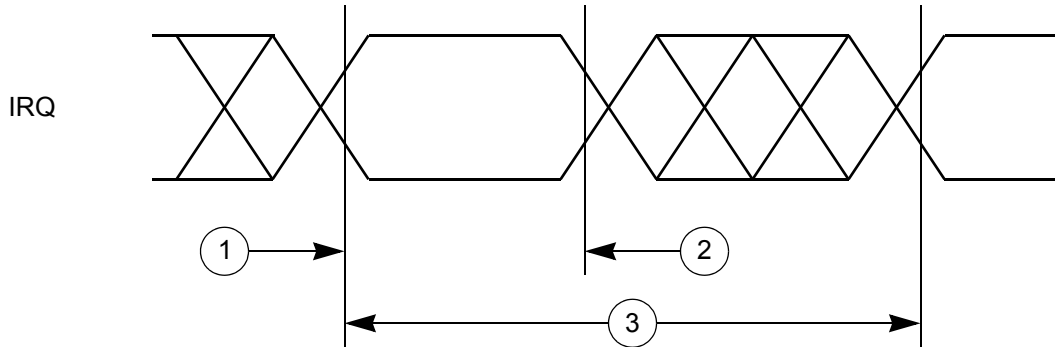

Figure 22. External Interrupt Timing

3.17.6 eTPU timing

Table 45. eTPU timing¹

#	Characteristic	Symbol	Min	Max	Unit
1	eTPU Input Channel Pulse Width	t_{ICPW}	4	—	t_{cyc}
2	eTPU Output Channel Pulse Width	t_{OCPW}	2 ²	—	t_{cyc}

¹ eTPU timing specified at $V_{DD} = 1.08 \text{ V to } 1.32 \text{ V}$, $V_{DDEH} = 3.0 \text{ V to } 5.5 \text{ V}$, V_{DD33} and $V_{DDSYN} = 3.0 \text{ V to } 3.6 \text{ V}$, $T_A = T_L$ to T_H , and $C_L = 200 \text{ pF}$ with $SRC = 0b00$.

² This specification does not include the rise and fall times. When calculating the minimum eTPU pulse width, include the rise and fall times defined in the slew rate control fields (SRC) of the pad configuration registers (PCR).

3.17.7 eMIOS timing

Table 46. eMIOS timing¹

#	Symbol	C	Characteristic	Min. Value	Max. Value	Unit	
1	t _{MIPW}	CC	D	eMIOS Input Pulse Width	4	—	t _{CYC}
2	t _{MOPW}	CC	D	eMIOS Output Pulse Width	1	—	t _{CYC}

¹ eMIOS timing specified at f_{SYS} = 80 MHz, V_{DD} = 1.14 V to 1.32 V, V_{DDEH} = 4.5 V to 5.5 V, T_A = T_L to T_H, and C_L = 50 pF with SRC = 0b00.

3.17.8 DSPI timing

DSPI channel frequency support for the MPC5644A MCU is shown in Table 47. Timing specifications are in Table 48.

Table 47. DSPI channel frequency support

System Clock (MHz)	DSPI Use Mode	Max. Usable Frequency (MHz)	Notes
150	LVDS	37.5	Use sysclock /4 divide ratio.
	Non-LVDS	18.75	Use sysclock /8 divide ratio.
120	LVDS	40	Use sysclock /3 divide ratio. Gives 33/66 duty cycle. Use DSPI configuration DBR=0b1 (double baud rate), BR=0b0000 (scaler value 2) and PBR=0b01 (prescaler value 3).
	Non-LVDS	20	Use sysclock /6 divide ratio.
80	LVDS	40	Use sysclock /2 divide ratio.
	Non-LVDS	20	Use sysclock /4 divide ratio.

Table 48. DSPI timing^{1,2}

#	Symbol	C	Characteristic	Condition	Min.	Max.	Unit
1	t _{SCK}	CC	D	SCK Cycle Time ^{3,4,5}	24.4 ns	2.9 ms	—
2	t _{CSC}	CC	D	PCS to SCK Delay ⁶	22 ⁷	—	ns
3	t _{ASC}	CC	D	After SCK Delay ⁸	21 ⁹	—	ns
4	t _{SDC}	CC	D	SCK Duty Cycle	(1/2t _{SC})–2	(1/2t _{SC})+2	ns
5	t _A	CC	D	Slave Access Time (SS active to SOUT driven)	—	25	ns
6	t _{DIS}	CC	D	Slave SOUT Disable Time (SS inactive to SOUT High-Z or invalid)	—	25	ns
7	t _{PCSC}	CC	D	PCSx to PCSS time	4 ¹⁰	—	ns
8	t _{PASC}	CC	D	PCSS to PCSx time	5 ¹¹	—	ns

Table 48. DSPI timing^{1,2} (continued)

#	Symbol	C	Characteristic	Condition	Min.	Max.	Unit	
9	t _{SUI}	CC	Data Setup Time for Inputs					
			D	Master (MTFE = 0)	V _{DDEH} =4.5–5.5 V	20	—	ns
			D		V _{DDEH} =3–3.6 V	23.5	—	
			D	Slave		2	—	
			D	Master (MTFE = 1, CPHA = 0) ¹²		8	—	
			D	Master (MTFE = 1, CPHA = 1)	V _{DDEH} =4.5–5.5 V	20	—	
			D		V _{DDEH} =3–3.6 V	23.5	—	
10	t _{HI}	CC	Data Hold Time for Inputs					
			D	Master (MTFE = 0)		-4	—	ns
			D	Slave		7	—	
			D	Master (MTFE = 1, CPHA = 0) ¹²		21	—	
			D	Master (MTFE = 1, CPHA = 1)		-4	—	
11	t _{SUO}	CC	Data Valid (after SCK edge)					
			D	Master (MTFE = 0)	V _{DDEH} =4.5–5.5 V	—	5	ns
			D		V _{DDEH} =3–3.6 V	—	6.3	
			D	Slave	V _{DDEH} =4.5–5.5 V	—	25	
			D		V _{DDEH} =3–3.6 V	—	27	
			D	Master (MTFE = 1, CPHA = 0)		—	21	
			D	Master (MTFE = 1, CPHA = 1)	V _{DDEH} =4.5–5.5 V	—	5	
			D		V _{DDEH} =3–3.6 V	—	6.3	
12	t _{HO}	CC	Data Hold Time for Outputs					
			D	Master (MTFE = 0)	V _{DDEH} =4.5–5.5 V	-5	—	ns
			D		V _{DDEH} =3–3.6 V	-7.5	—	
			D	Slave		5.5	—	
			D	Master (MTFE = 1, CPHA = 0)		3	—	
			D	Master (MTFE = 1, CPHA = 1)	V _{DDEH} =4.5–5.5 V	-5	—	
			D		V _{DDEH} =3–3.6 V	-7.5	—	

¹ All DSPI timing specifications use the fastest slew rate (SRC = 0b11) on medium-speed pads. DSPI signals using slow pads have an additional delay based on the slew rate. DSPI timing is specified at V_{DDEH} = 3 to 3.6 V and V_{DDEH} = 4.5 to 5.5 V, T_A = T_L to T_H, and C_L = 50 pF with SRC = 0b11.

² Data is verified at f_{SYS} = 102 MHz and 153 MHz (100 MHz and 150 MHz + 2% frequency modulation).

³ The minimum DSPI Cycle Time restricts the baud rate selection for given system clock rate. These numbers are calculated based on two MPC5644A devices communicating over a DSPI link.

- 4 The actual minimum SCK cycle time is limited by pad performance.
- 5 For DSPI channels using LVDS output operation, up to 40 MHz SCK cycle time is supported. For non-LVDS output, maximum SCK frequency is 20 MHz. Appropriate clock division must be applied.
- 6 The maximum value is programmable in DSPI_CTARx[PSSCK] and DSPI_CTARx[CSSCK].
- 7 Timing met when pcssck = 3(01), and cssck =2 (0000).
- 8 The maximum value is programmable in DSPI_CTARx[PASC] and DSPI_CTARx[ASC].
- 9 Timing met when ASC = 2 (0000), and PASC = 3 (01).
- 10 Timing met when pcssck = 3.
- 11 Timing met when ASC = 3.
- 12 This number is calculated assuming the SMPL_PT bitfield in DSPI_MCR is set to 0b10.

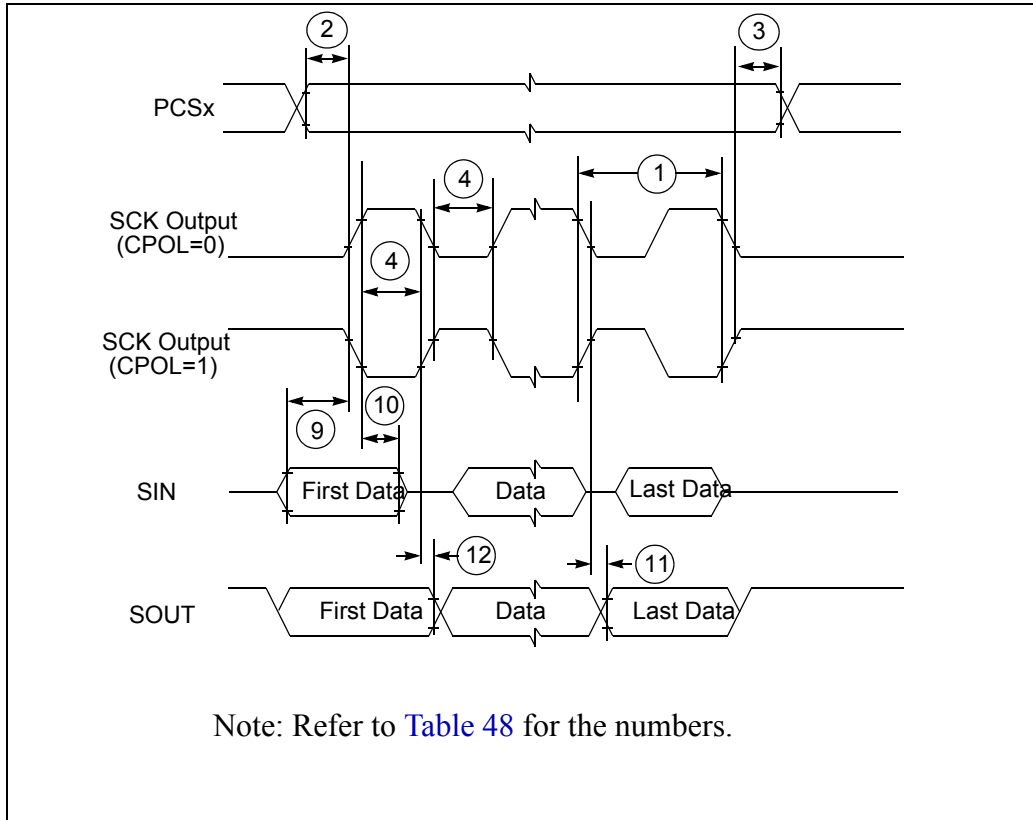

Figure 23. DSPI classic SPI timing — master, CPHA = 0

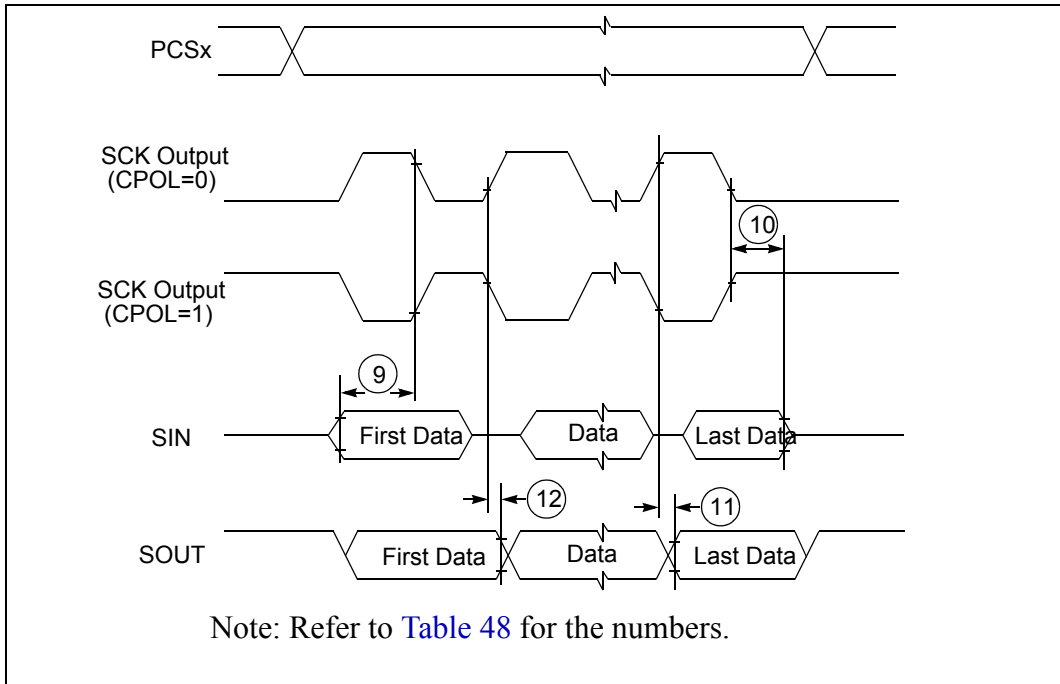

Figure 24. DSPI classic SPI timing — master, CPHA = 1

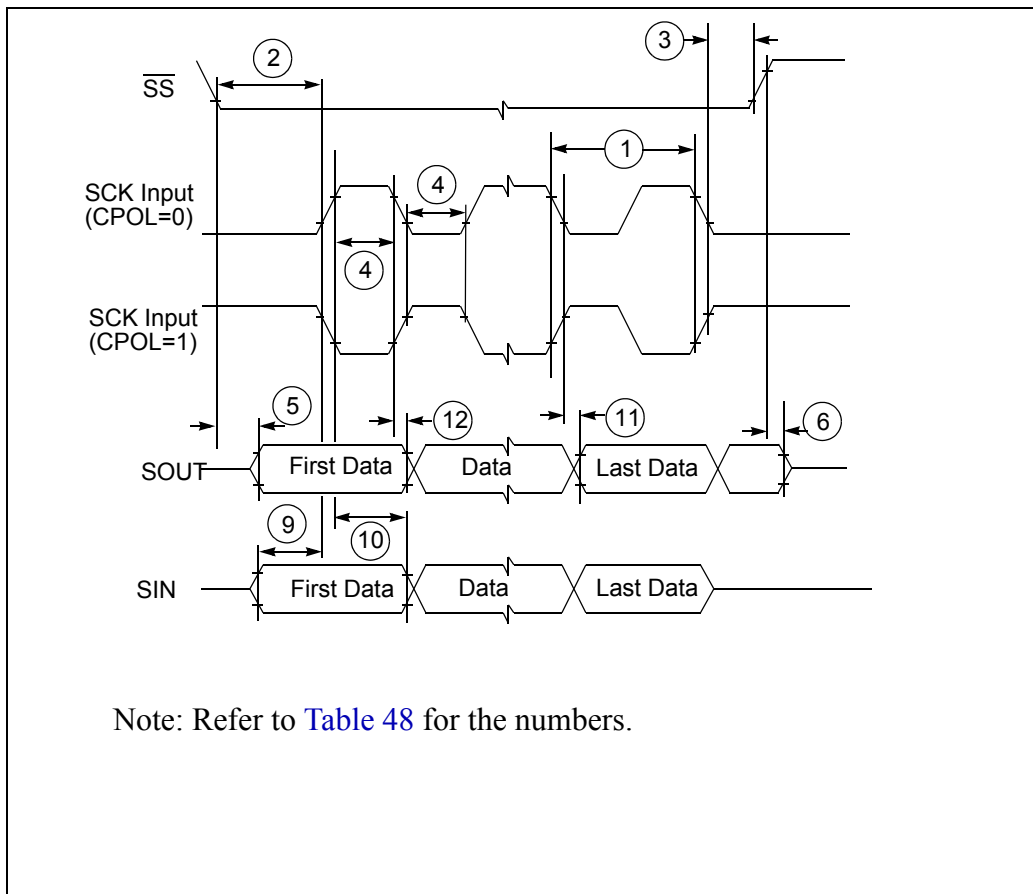

Figure 25. DSPI classic SPI timing — slave, CPHA = 0

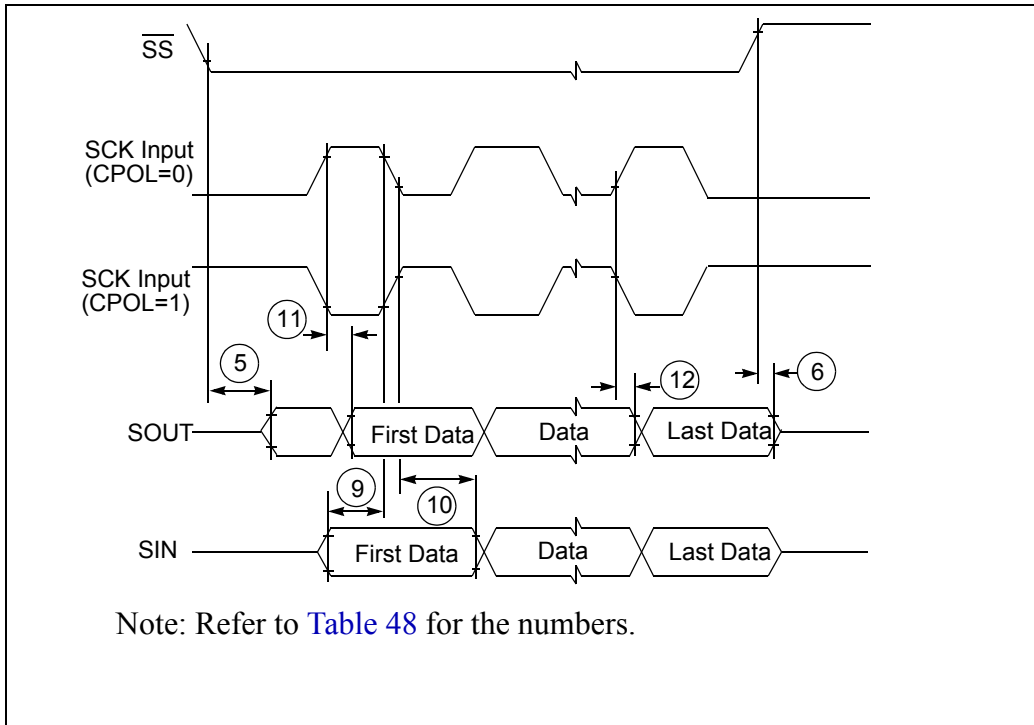

Figure 26. DSPI classic SPI timing — slave, CPHA = 1

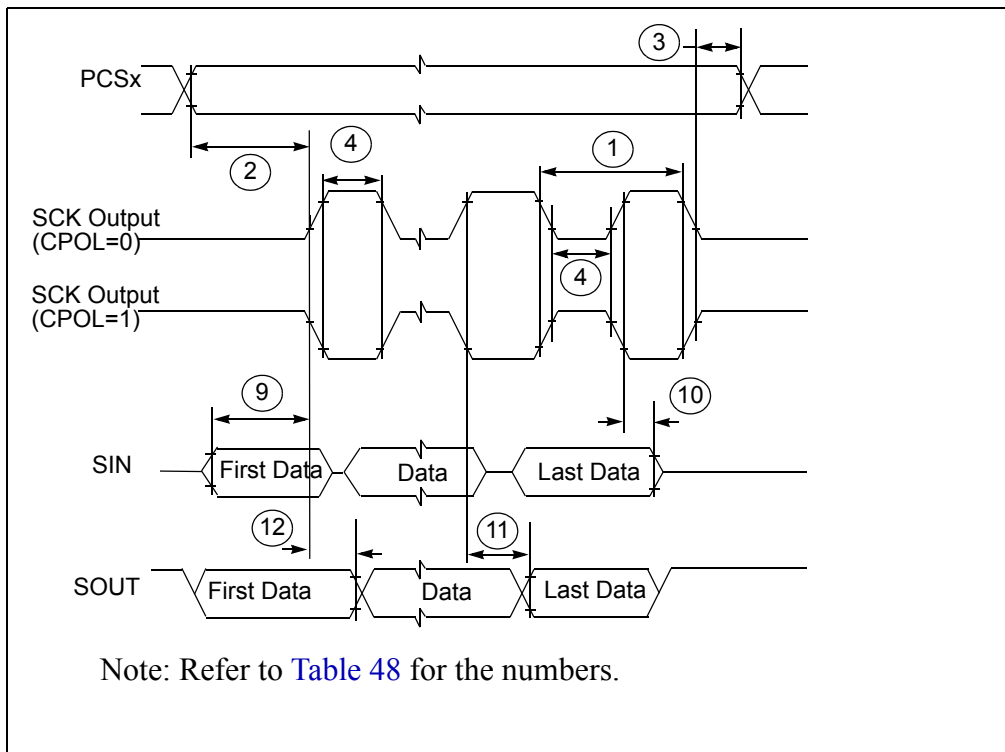

Figure 27. DSPI modified transfer format timing — master, CPHA = 0

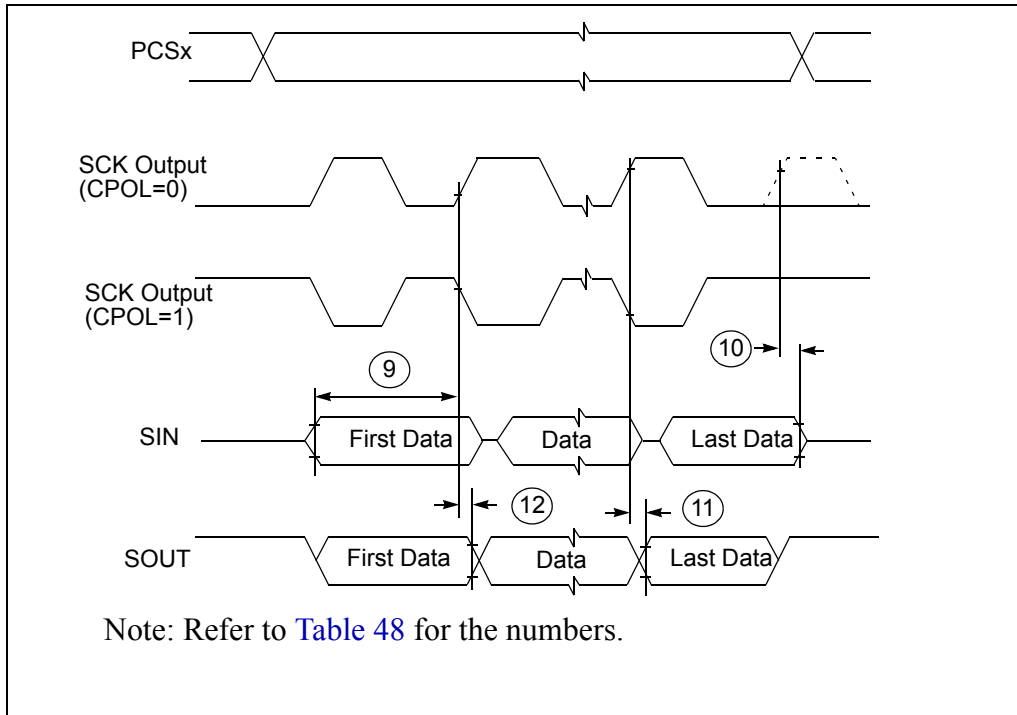

Figure 28. DSPI modified transfer format timing — master, CPHA = 1

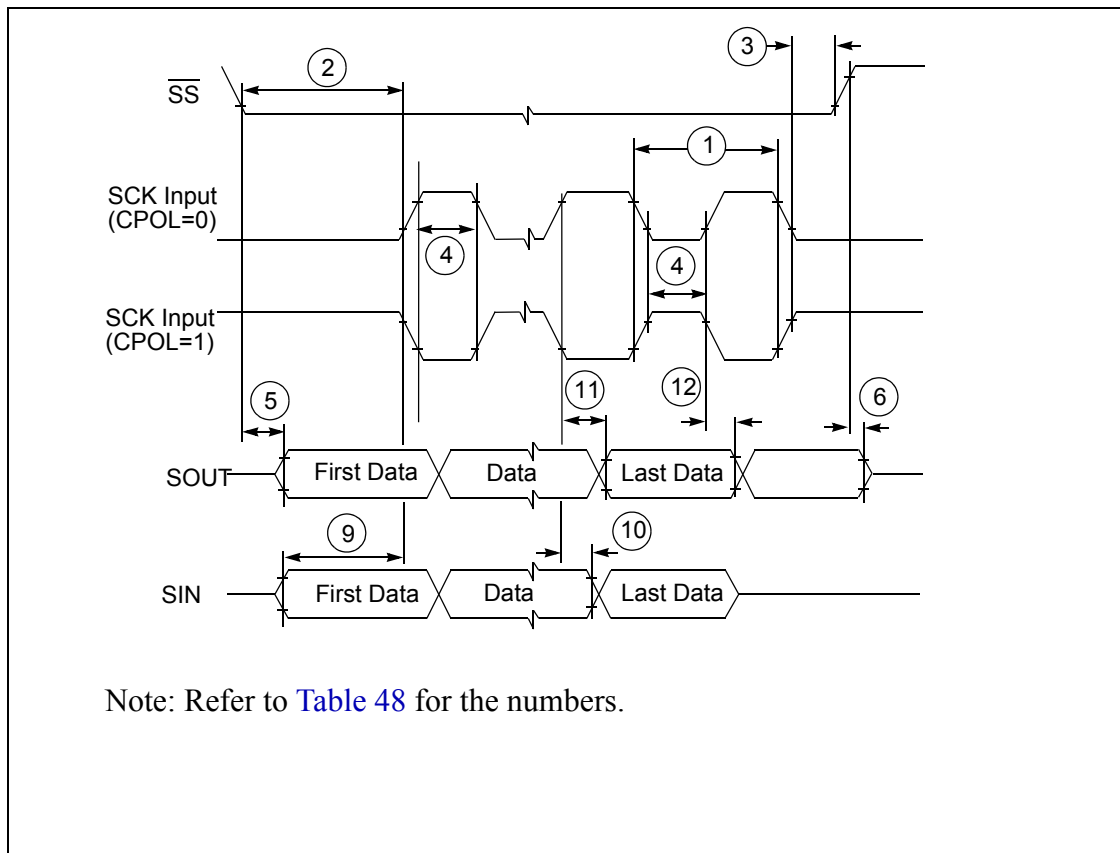

Figure 29. DSPI modified transfer format timing — slave, CPHA = 0

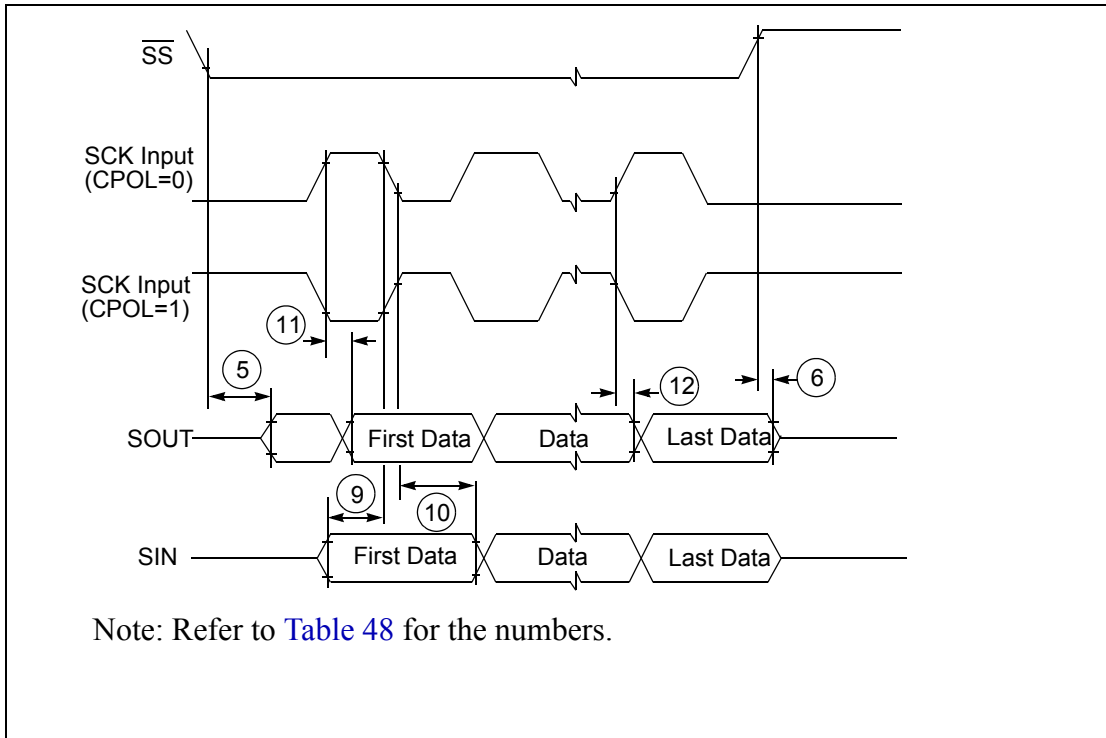

Figure 30. DSPI modified transfer format timing — slave, CPHA =1

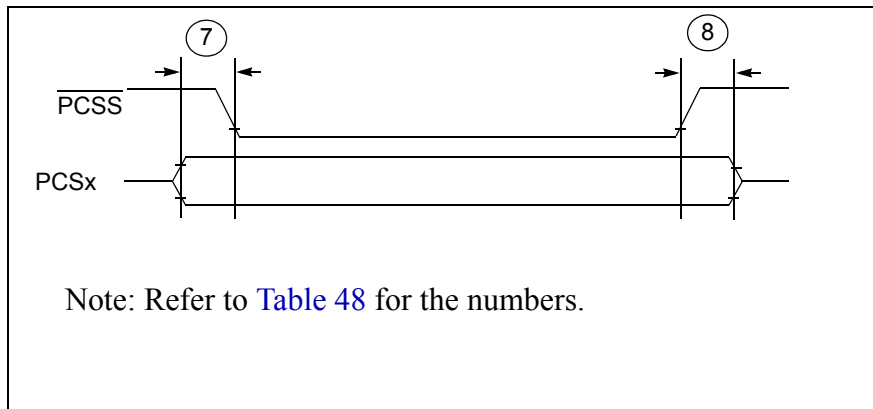

Figure 31. DSPI PCS strobe (PCSS) timing

3.17.9 eQADC SSI timing

Table 49. eQADC SSI timing characteristics (pads at 3.3 V or at 5.0 V)¹

CLOAD = 25 pF on all outputs. Pad drive strength set to maximum.							
#	Symbol	C	Rating	Min	Typ	Max	Unit
1	f_{FCK}	CC	D	FCK Frequency ^{2, 3}	1/17	1/2	f_{SYS_CLK}
1	t_{FCK}	CC	D	FCK Period ($t_{FCK} = 1/f_{FCK}$)	2	17	t_{SYS_CLK}
2	t_{FCKHT}	CC	D	Clock (FCK) High Time	$t_{SYS_CLK} - 6.5$	$9 * t_{SYS_CLK} + 6.5$	ns
3	t_{FCKLT}	CC	D	Clock (FCK) Low Time	$t_{SYS_CLK} - 6.5$	$8 * t_{SYS_CLK} + 6.5$	ns
4	t_{SDS_LL}	CC	D	SDS Lead/Lag Time	-7.5	7.5	ns
5	t_{SDO_LL}	CC	D	SDO Lead/Lag Time	-7.5	7.5	ns
6	t_{DVFE}	CC	D	Data Valid from FCK Falling Edge ($t_{FCKLT} + t_{SDO_LL}$)	1		ns
7	t_{EQ_SU}	CC	D	eQADC Data Setup Time (Inputs)	22		ns
8	t_{EQ_HO}	CC	D	eQADC Data Hold Time (Inputs)	1		ns

¹ SS timing specified at $f_{SYS} = 80$ MHz, $V_{DD} = 1.14$ V to 1.32 V, $V_{DDEH} = 4.5$ V to 5.5 V, $T_A = T_L$ to T_H , and $C_L = 50$ pF with SRC = 0b00.

² Maximum operating frequency is highly dependent on track delays, master pad delays, and slave pad delays.

³ FCK duty is not 50% when it is generated through the division of the system clock by an odd number.

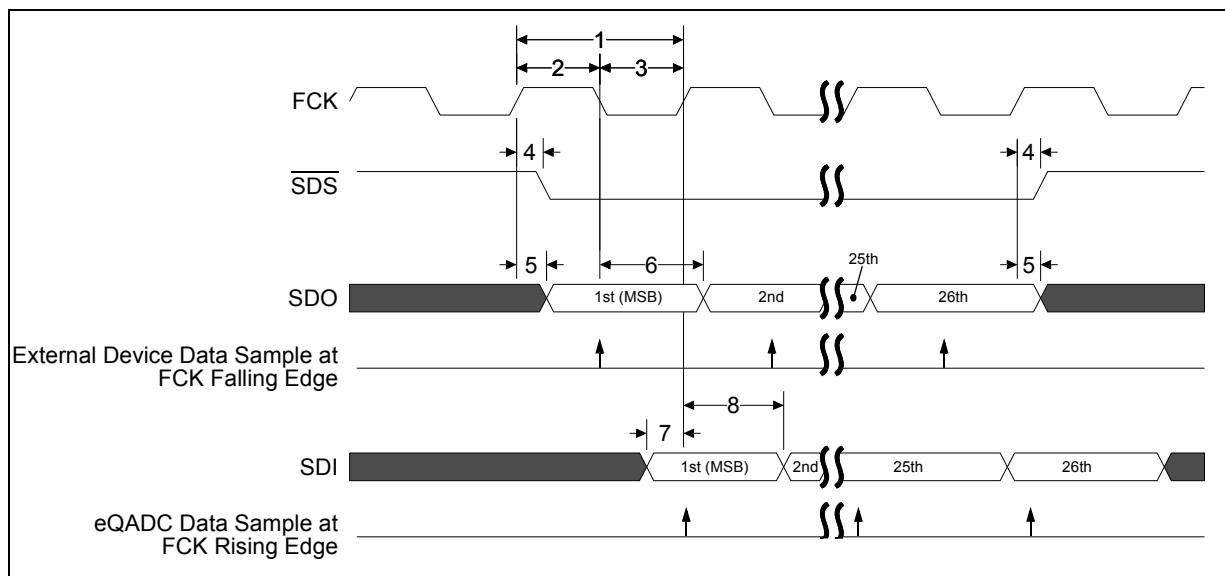

Figure 32. eQADC SSI timing

3.17.10 FlexCAN system clock source

Table 50. FlexCAN engine system clock divider threshold

#	Symbol	Characteristic	Value	Unit
1	F _{CAN_TH}	FlexCAN engine system clock threshold	100	MHz

Table 51. FlexCAN engine system clock divider

System Frequency	Required SIU_SYSDIV[CAN_SRC] Value
$\leq F_{CAN_TH}$	0 ^{1,2}
$> F_{CAN_TH}$	1 ^{2,3}

¹ Divides system clock source for FlexCAN engine by 1.

² System clock is only selected for FlexCAN when CAN_CR[CLK_SRC] = 1.

³ Divides system clock source for FlexCAN engine by 2.

4 Packages

4.1 Package mechanical data

4.1.1 176 LQFP

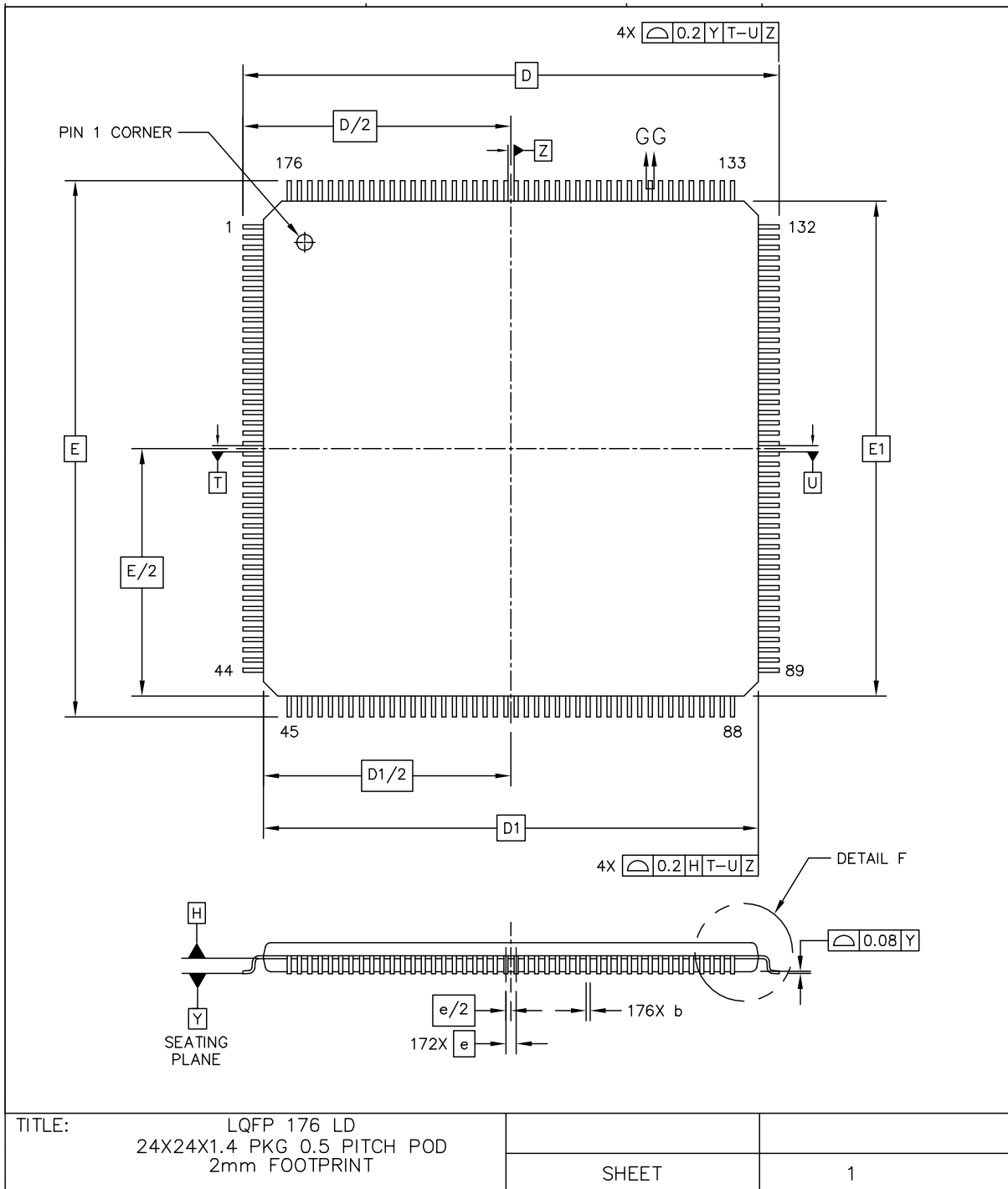

Figure 33. 176 LQFP package mechanical drawing (part 1)

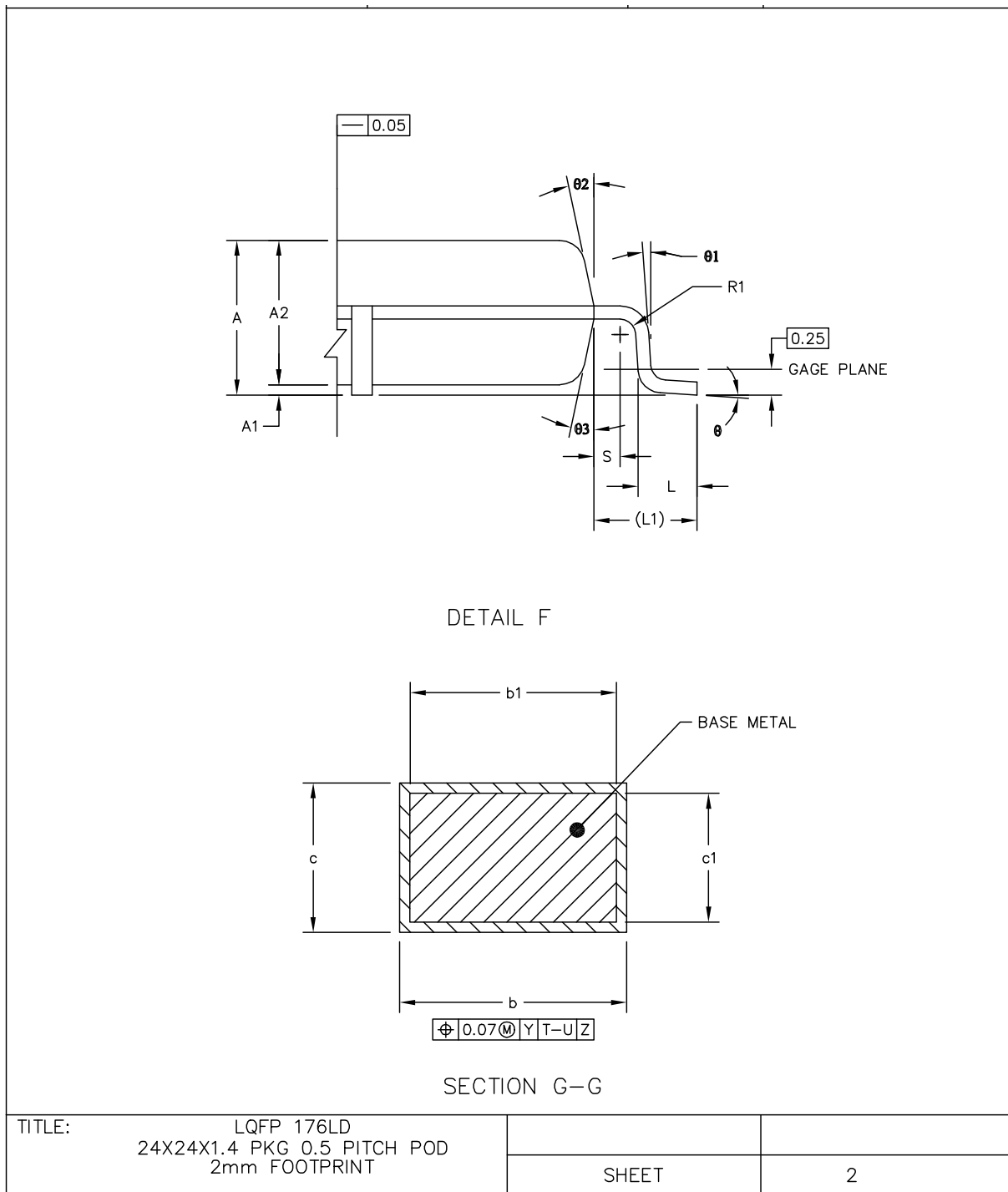

Figure 34. 176 LQFP package mechanical drawing (part 2)

NOTES:

1. DIMENSIONS D1 AND E1 DO NOT INCLUDE MOLD PROTRUSION. ALLOWABLE PROTRUSION IS 0.25MM PER SIDE. DIMENSIONS D1 AND E1 DO INCLUDE MOLD MISMATCH AND ARE DETERMINED AT DATUM PLANE DATUM H.
2. DIMENSION b DOES NOT INCLUDE DAMBAR PROTRUSION. DAMBAR PROTRUSION. ALLOWABLE DAMBAR PROTRUSION SHALL NOT CAUSE THE LEAD WIDTH TO EXCEED THE MAXIMUM b DIMENSION BY MORE THEN 0.08MM. DAMBAR CAN NOT BE LOCATED ON THE LOWER RADIUS OR THE FOOT. MINIMUM BETWEEN PROTRUSION AND AN ADJACENT LEAD IS 0.07MM FOR 0.4MM AND 0.5MM PITCH PACKAGES.

DIM	MIN	NOM	MAX	DIM	MIN	NOM	MAX	DIM	MIN	NOM	MAX
A	---		1.6	L1		1 REF					
A1	0.05		0.15	R1	0.08		---				
A2	1.35	1.4	1.45	R2	0.08		0.2				
b	0.17	0.22	0.27	S		0.2 REF					
b1	0.17	0.2	0.23	θ	0°	3.5°	7°				
c	0.09		0.2	$\theta 1$	0°		---				
c1	0.09		0.16	$\theta 2$	11°	12°	13°				
D		26 BSC		$\theta 3$	11°	12°	13°				
D1		24 BSC									
e		0.5 BSC									
E		26 BSC									
E1		24 BSC									
L	0.45	0.6	0.75								
				UNIT		DIMENSION AND TOLERANCES		REFERANCE DOCUMENT			
				MM		ASME Y14.5M		64-06-280-1392			
TITLE:				LQFP 176LD 24X24X1.4 PKG 0.5 PITCH POD 2mm FOOTPRINT				SHEET		3	

Figure 35. 176 LQFP package mechanical drawing (part 3)

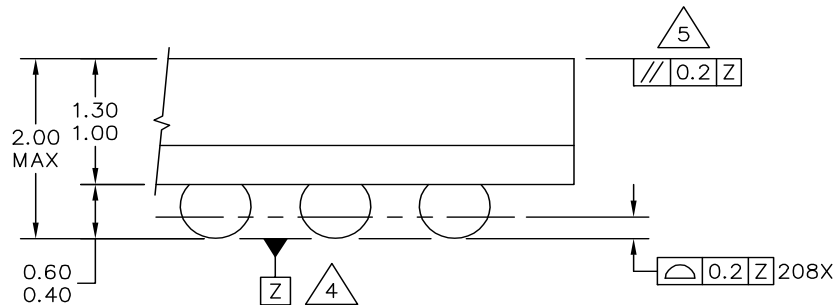

DETAIL K
(ROTATED 90° CLOCKWISE)

NOTES:

1. ALL DIMENSIONS ARE IN MILLIMETERS.
2. INTERPRET DIMENSIONS AND TOLERANCES PER ASME Y14.5M-1994.
3. DIMENSION b IS MEASURED AT THE MAXIMUM SOLDER BALL DIAMETER, PARALLEL TO DATUM PLANE Z.
4. DATUM Z (SEATING PLANE) IS DEFINED BY THE SPHERICAL CROWNS OF THE SOLDER BALLS.
5. PARALLELISM MEASUREMENT SHALL EXCLUDE ANY EFFECT OF MARK ON TOP SURFACE OF PACKAGE.

TITLE: 208 I/O MAP BGA, 17 X 17 PKG, 1-MM PITCH	CASE NUMBER: 1159A-01	
	STANDARD: JEDEC MO-151 AAF-1	
	PACKAGE CODE: 5253	SHEET: 2

Figure 37. 208 MAPBGA package mechanical drawing (part 2)

4.1.3 324 TEPBGA

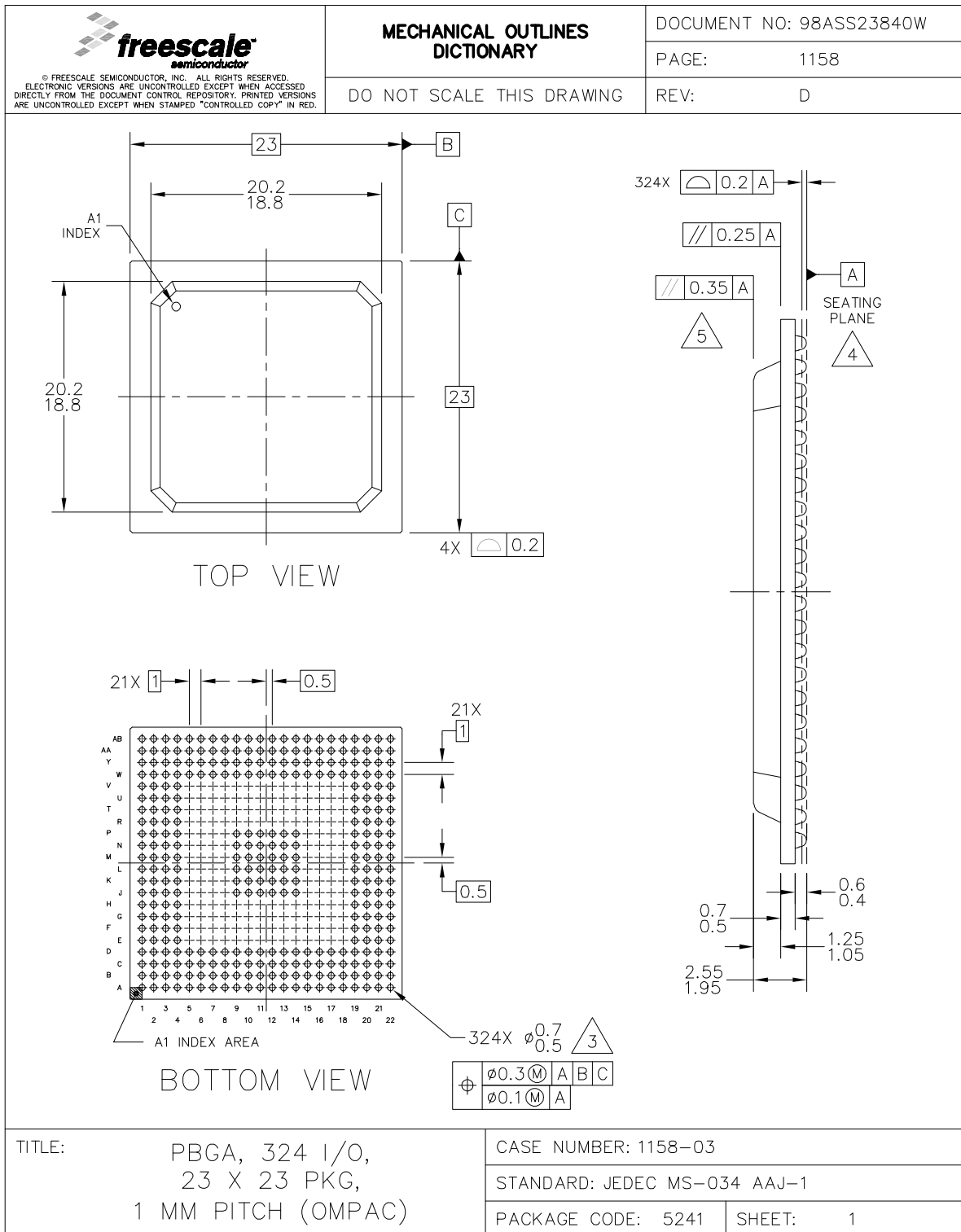

Figure 38. 324 BGA package mechanical drawing (part 1)

 <small>© FREESCALE SEMICONDUCTOR, INC. ALL RIGHTS RESERVED. ELECTRONIC VERSIONS ARE UNCONTROLLED EXCEPT WHEN ACCESSED DIRECTLY FROM THE DOCUMENT CONTROL REPOSITORY. PRINTED VERSIONS ARE UNCONTROLLED EXCEPT WHEN STAMPED "CONTROLLED COPY" IN RED.</small>	MECHANICAL OUTLINES DICTIONARY		DOCUMENT NO: 98ASS23840W	
	DO NOT SCALE THIS DRAWING		PAGE:	1158
			REV:	D
<p>NOTES:</p> <ol style="list-style-type: none"> 1. ALL DIMENSIONS IN MILLIMETERS. 2. DIMENSIONING AND TOLERANCING PER ASME Y14.5M-1994. 3. MAXIMUM SOLDER BALL DIAMETER MEASURED PARALLEL TO DATUM A. 4. DATUM A, THE SEATING PLANE, IS DETERMINED BY THE SPHERICAL CROWNS OF THE SOLDER BALLS. 5. PARALLELISM MEASUREMENT SHALL EXCLUDE ANY EFFECT OF MARK ON TOP SURFACE OF PACKAGE. 				
TITLE: PBGA, 324 I/O, 23 X 23 PKG, 1 MM PITCH (OMPAC)		CASE NUMBER: 1158-03		
		STANDARD: JEDEC MS-034 AAJ-1		
		PACKAGE CODE: 5241	SHEET:	2

Figure 39. 324 BGA package mechanical drawing (part 2)

5 Ordering information

Table 52 shows the orderable part numbers for the MPC5644A series.

Table 52. Orderable part number summary

Part number	Flash/SRAM	Package	Speed (MHz)
SPC5643AF0MLU3	3 MB/192 KB	176LQFP (Pb free)	80
SPC5643AF0MMG3	3 MB/192 KB	208MAPBGA(Pb free)	80
SPC5643AF0MVZ3	3 MB/192 KB	324PBGA (Pb free)	80
SPC5643AF0MLU2	3 MB/192 KB	176LQFP (Pb free)	120
SPC5643AF0MMG2	3 MB/192 KB	208MAPBGA (Pb free)	120
SPC5643AF0MVZ2	3 MB/192 KB	324PBGA (Pb free)	120
SPC5643AF0MLU1	3 MB/192 KB	176LQFP (Pb free)	150
SPC5643AF0MMG1	3 MB/192 KB	208MAPBGA (Pb free)	150
SPC5643AF0MVZ1	3 MB/192 KB	324PBGA (Pb free)	150
SPC5644AF0MLU3	4 MB/192 KB	176 LQFP (Pb free)	80
SPC5644AF0MMG3	4 MB/192 KB	208 MAPBGA (Pb free)	80
SPC5644AF0MVZ3	4 MB/192 KB	324 TEPBGA (Pb free)	80
SPC5644AF0MLU2	4 MB/192 KB	176 LQFP (Pb free)	120
SPC5644AF0MMG2	4 MB/192 KB	208 MAPBGA (Pb free)	120
SPC5644AF0MVZ2	4 MB/192 KB	324 TEPBGA (Pb free)	120
SPC5644AF0MLU1	4 MB/192 KB	176 LQFP (Pb free)	150
SPC5644AF0MMG1	4 MB/192 KB	208 MAPBGA (Pb free)	150
SPC5644AF0MVZ1	4 MB/192 KB	324 TEPBGA (Pb free)	150

Figure 40. Product code structure

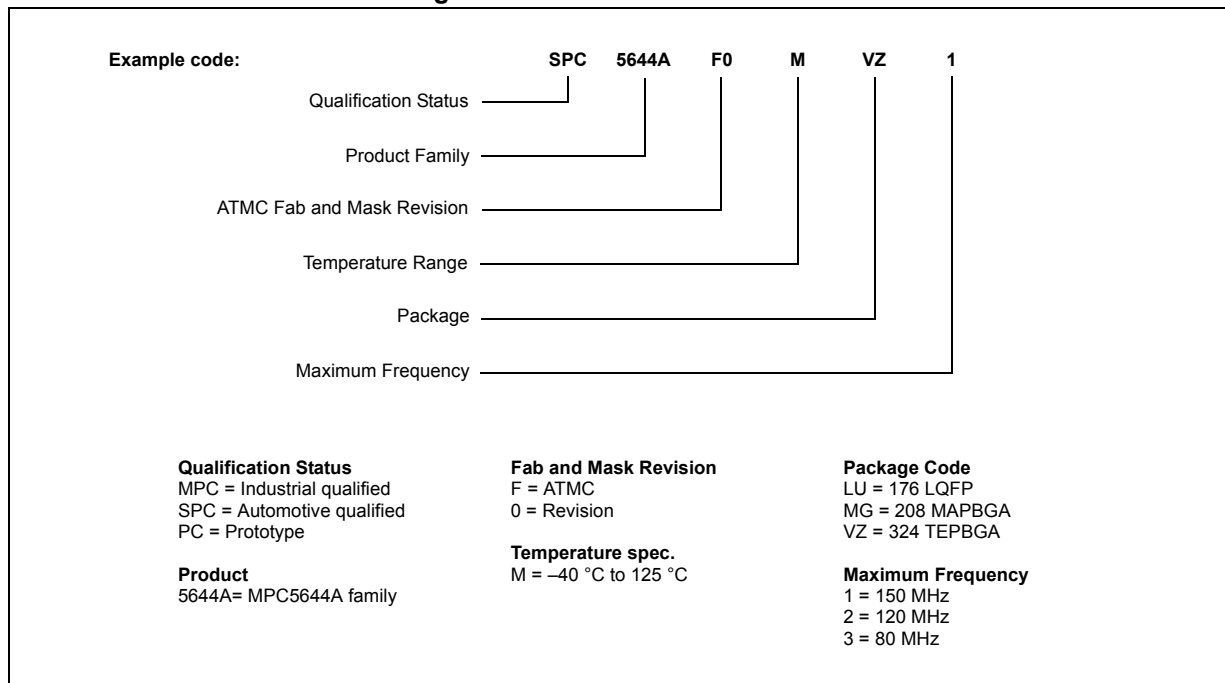

6 Document revision history

Table 53 summarizes revisions to this document.

Table 53. Revision history

Revision	Date	Substantive changes
Rev. 1	4/2008	Initial release

Table 53. Revision history (continued)

Revision	Date	Substantive changes
Rev. 2	11/2009	<p>Maximum device speed is 145 MHz (was 150 MHz)</p> <p>16-entry Memory Protection Unit (MPU). Was incorrectly listed as 8-entry.</p> <p>Feature details section added</p> <p>Changes to signal summary table:</p> <ul style="list-style-type: none"> • Added ANY function to AN[10] • Added ANW function to AN[8] <p>Changes to 208 ball BGA ballmap:</p> <ul style="list-style-type: none"> • A12 is AN12-SDS (was AN12) • A15 is VRC33 (was VDD33) • B12 is AN13-SDO (was AN13) • C12 is AN14SDI (was AN14) • C13 is AN15-FCK (was AN15) • D1 is VRC33 (was VDD33) • F13 is VDDEH6AB (was VDDEH6) • H13 is GPIO99 (was PCSA3) • J15 is GPIO98 (was PCSA2) • K4 is now VDDEH1AB (was VDDEH1) • N6 is now VRC33 (was VDD33) • N9 is VDDEH4AB (was VDDEH4) • N12 is now VRC33 (was VDD33) • P6 is now NC • T13 is VDDE5 (was NC)
Rev. 2	11/2009 (cont.)	<p>Recommended operating characteristics for power transistor updated</p> <p>Pad current specifications updated</p> <p>LVDS pad specifications updated. SRC does not apply to common mode voltage.</p> <p>Temperature sensor electrical characteristics added</p> <p>eQADC electrical characteristics updated with VGA gain specs</p> <p>Pad AC specifications updated</p> <p>Definition for RDY signal added to signal details</p> <p>V_{STBY} maximum is 5.5 V (was listed incorrectly as 6.0 V)</p> <p>I_{MAXA} maximum is 5 mA (was TBD)</p> <p>Analog differential input functions added to AN0–AN7 in signal summary</p>

Table 53. Revision history (continued)

Revision	Date	Substantive changes
Rev. 3	04/2010	<p>Changes to Signal Properties table (changes apply to Revision 2 and later devices):</p> <p>EBI changes:</p> <ul style="list-style-type: none"> • WE_BE[2] (A2) and CAL_WE_BE[2] (A3) signals added to CS[2] (PCR 2) • WE_BE[3] (A2) and CAL_WE_BE[3] (A3) signals added to CS[3] (PCR 3) <p>Calibration bus changes:</p> <ul style="list-style-type: none"> • CAL_WE[2]/BE[2] (A2) signal added to CAL_CS[2] (PCR 338) • CAL_WE[3]/BE[3] (A2) signal added to CAL_CS[3] (PCR 339) • CAL_ALE (A1) added to CAL_ADDR[15] (PCR 340) <p>eQADC changes:</p> <ul style="list-style-type: none"> • AN[8] and AN[38] pins swapped. AN[8] is now on pins 9 (176-pin), B3 (208-ball) and E1 (324-ball). AN[8] was on D3 (324-ball) on previous devices. AN[38] is now on D3 (324-ball). AN[38] was on pins 9 (176-pin), B3 (208-ball) and E1 (324-ball) on previous devices. • ANZ function added to AN11 pin <p>Reaction channels added to eTPU2:</p> <ul style="list-style-type: none"> • RCH0_A (A3) added to ETPU_A[14] (PCR 128) • RCH0_B (A2) added to ETPU_A[20] (PCR 134) • RCH0_C (A2) added to ETPU_A[21] (PCR 135) • RCH1_A (A2) added to ETPU_A[15] (PCR 129) • RCH1_B (A2) added to ETPU_A[9] (PCR 123) • RCH1_C (A2) added to ETPU_A[10] (PCR 124) • RCH2_A (A2) added to ETPU_A[16] (PCR 130) • RCH3_A (A2) added to ETPU_A[17] (PCR 131) • RCH4_A (A2) added to ETPU_A[18] (PCR 132) • RCH4_B (A2) added to ETPU_A[11] (PCR 125) • RCH4_C (A2) added to ETPU_A[12] (PCR 126) • RCH5_A (A2) added to ETPU_A[19] (PCR 133) • RCH5_B (A2) added to ETPU_A[28] (PCR 142) • RCH5_C (A2) added to ETPU_A[29] (PCR 143) <p>Reaction channels added to eMIOS:</p> <ul style="list-style-type: none"> • RCH2_B (A2) added to EMIOS[2] (PCR 181) • RCH2_C (A2) added to EMIOS[4] (PCR 183) • RCH3_B (A2) added to EMIOS[10] (PCR 189) • RCH3_C (A2) added to EMIOS[11] (PCR 190) <p>Pad changes:</p> <ul style="list-style-type: none"> • ETPUA16 (PCR 130) has Medium (was Slow) pad • ETPUA17 (PCR 131) has Medium (was Slow) pad • ETPUA18 (PCR 132) has Medium (was Slow) pad • ETPUA19 (PCR 133) has Medium (was Slow) pad • ETPUA25 (PCR 139) has Slow+LVDS (was Medium+LVDS) pads <p>Signal Details table updated:</p> <ul style="list-style-type: none"> • Added eTPU2 reaction channels • Changed IRQ[0:15] to two ranges, excluding IRQ6, which does not exist on this device • Changed TCR_A to TCRCLKA (TCR_A is the pin name, not the signal name) • Changed WE_BE[0:1] to WE_BE[0:3] (2 new signals added to Rev. 2). Also changed notation from "WE_BE[n]" to "WE[n]/BE[n]" to be consistent.

Table 53. Revision history (continued)

Revision	Date	Substantive changes
Rev. 3 (cont)	04/2010	<p>Changes to Power/ground segmentation table:</p> <ul style="list-style-type: none"> • ADDR[20:21] removed from VDDE2 segment; they are in VDDE-EH • CAL_CS1 removed from VDDE12 segment (there is no CAL_CS1 on this device) • CAL_EVTO and CAL_MCKO removed from VDDE12 segment. Those pins do not exist • VDDE-VDDEH renamed to VDDE-EH • EMIOS24 removed from VDDEH segment. That pin does not exist. • ETPUA[0:9] added to VDDEH4 segment • Renamed TCR_A in VDDEH4 segment to TCRCLKA. • EXTAL and XTAL added to VDDEH6 segment • AN15-FCK added to VDDEH7 segment • GPIO98, GPIO99, GPIO206, GPIO207 and GPIO219 added to VDDEH7 segment. • MSEO1 added to VDDEH7 segment • Power segment VDDEH1A renamed to VDDEH1 <p>Changes to 176-pin package pinout:</p> <ul style="list-style-type: none"> • Changed pin 9 from AN38 to AN8. • Added note that pin 96 (VSS) should be tied low. <p>Changes to 208-ball package ballmap:</p> <ul style="list-style-type: none"> • Changed ball B3 from AN38 to AN8. • Added note that ball N13 (VSS) should be tied low. <p>324-ball package ballmap updated for Rev. 2 silicon:</p> <ul style="list-style-type: none"> • AN8 was on ball D3; it is now on E1 • AN38 was on ball E1; it is now on D3 <p>Changes to features list:</p> <ul style="list-style-type: none"> • Correction: there are 6 reaction channels (was noted as 5) • Development Trigger Semaphore (DTS) added to features list and feature details • FlexRay module now has 128 message buffers (was 64) and ECC support <p>Added note after JTAG pin AC electrical characteristics table detailing JTAG EVTI and RDY signal clocking with TCK. This affects debuggers.</p> <p>Part numbers and part number decoder updated.</p>

Table 53. Revision history (continued)

Revision	Date	Substantive changes
Rev. 3 (cont)	04/2010	<p>Added information to AC timings section:</p> <ul style="list-style-type: none"> • New section added: Reset and configuration pin timing • New section added: External interrupt timing (IRQ pin) • New section added: eTPU timing • Added Nexus debug port operating frequency table to Nexus timings section • Added external bus interface maximum operating frequency table and calibration bus interface maximum operation frequency table • Added FlexCAN system clock source section <p>Changes to Power management control (PMC) and power on reset (POR) electrical specifications:</p> <ul style="list-style-type: none"> • Max value for parameter 2 (vddreg) is 5.25 V (was 5.5 V) <p>Updated “Core voltage regulator controller external components preferred configuration” diagram.</p> <p>Changes to DC electrical specifications table:</p> <ul style="list-style-type: none"> • Slew rate on power supply pins (system requirement) changed to 25 V/ms (was 50 V/ms) <p>Throughout the document the maximum frequency is now 150 MHz (was 145 MHz)</p> <p>Changes to DC electrical specifications:</p> <ul style="list-style-type: none"> • Parameter classifications added • V_{DDREG} max value changed to 5.25 V (was 5.5 V) • V_{OH_LS} min value changed to 2.0 V (was 2.7 V) with a load current of 0.5 mA • V_{OL_LS} max value changed to 0.6 V (was $0.2 \cdot V_{DDEH}$) with load current of 2 mA • V_{INDC} min value changed to $V_{SSA}-0.3$ (was $V_{SSA}-1.0$) • V_{INDC} max value changed to $V_{DDA}+0.3$ (was $V_{DDA}+1.0$) <p>Added new section: Configuring SRAM wait states</p> <p>VRCCTL external circuit updated.</p>

Table 53. Revision history (continued)

Revision	Date	Substantive changes
Rev. 4	08/2010	<p>Updates to Nexus timings:</p> <ul style="list-style-type: none"> • t_{MDOV} max value changed to 0.35 (was 0.2) • t_{MSEOV} max value changed to 0.35 (was 0.2) • t_{EVTOV} max value changed to 0.35 (was 0.2) <p>Updates to DC electrical specifications:</p> <ul style="list-style-type: none"> • V_{STBY} min value changed to 0.95 V (was 0.9 V) • V_{STBY} has two ranges—for regulated mode and unregulated mode <p>Correction to PLLMRFM electrical specifications:</p> <ul style="list-style-type: none"> • V_{DDPLL} range is from 1.08 V to 3.6 V (was 3.0 V to 3.6 V). <p>Updates to pad AC specifications:</p> <ul style="list-style-type: none"> • Specs with drive load = 200 pF deleted. DSC (drive strength control) values range from 10 – 50 pF. • I/O pad average I_{DDE} specifications updated (fast pad specs only) • I/O pad V_{RC33} average I_{DDE} specifications (fast pad specs only) <p>Updates to Reset and configuration pin timings:</p> <ul style="list-style-type: none"> • Footnote added: \overline{RESET} pulse width is measured from 50% of the falling edge to 50% of the rising edge. • Timings are specified at $V_{DD} = 1.14$ V to 1.32 V (was 1.08 V to 1.32 V). <p>Updates to EBI timings:</p> <ul style="list-style-type: none"> • Note added to t_{AAI}: When CAL_TS is used as CAL_ALE the hold time is 1 ns instead of 1.5 ns. • Correction: maximum calibration bus interface operating frequency is 66 MHz for all port configurations. • VDDE range in footnote 1 corrected to read, “External Bus and Calibration bus timing specified at $f_{SYS} = 150$ MHz and 100 MHz, $V_{DD} = 1.14$ V to 1.32 V, $V_{DDE} = 3$ V to 3.6 V (unless stated otherwise)” (VDDE range was 1.62 V to 3.6 V) <p>Correction to IEEE 1149.1 timings:</p> <ul style="list-style-type: none"> • SRC value in footnote 1 corrected to read, “JTAG timing specified at $V_{DD} = 1.14$ V to 1.32 V, $V_{DDEH} = 4.5$ V to 5.5 V with multi-voltage pads programmed to Low-Swing mode, TA = TL to TH, and CL = 30 pF with DSC = 0b10, SRC = 0b11.” (SRC value was 0b00) <p>Correction to External interrupt timing (IRQ pin) timings:</p> <ul style="list-style-type: none"> • Timings are specified at $V_{DD} = 1.14$ V to 1.32 V (was 1.08 V to 1.32 V). <p>Update to DSPI timings:</p> <ul style="list-style-type: none"> • Some of the timing parameters can vary depending on the value of V_{DDE}. For these parameters, ranges are now defined for two ranges of V_{DDE}.

Table 53. Revision history (continued)

Revision	Date	Substantive changes
Rev. 4 (cont)	08/2010	<p>Change in signal name notation for DSPI, CAN and SCI signals:</p> <p>DSPI: PCS_x[n] is now DSPI_x_PCS[n] SOUT_x is now DSPI_x_SOUT SIN_x is now DSPI_x_SIN SCK_x is now DSPI_x_SCK</p> <p>CAN: CNTXx is now CAN_x_TX CNRXx is now CAN_x_RX</p> <p>SCI: RXDx is now SCI_x_RX TXDx is now SCI_x_TX</p> <p>Updates to DC electrical specifications:</p> <ul style="list-style-type: none"> • Slew rate on power supply pins specification changed to 25 V/ms (was 50 V/ms) <p>V_{OH_LS} min spec changed to 2.0 V at 0.5 mA (was 2.7 V at 0.5 mA)</p> <p>Updated I/O pad current specifications</p> <p>Updated I/O pad V_{RC33} current specifications</p> <p>Corrections to Nexus timing:</p> <ul style="list-style-type: none"> • Maximum Nexus debug port operating frequency is 40 MHz in all configurations • To route Nexus to MDO, clear NPC_PCR[NEXCFG] (formerly this was documented as NPC_PCR[CAL]) • To route Nexus to CAL_MDO, set NPC_PCR[NEXCFG]=1 (formerly this was documented as NPC_PCR[CAL])

Table 53. Revision history (continued)

Revision	Date	Substantive changes
Rev. 5	2/2011	<ul style="list-style-type: none"> • Minor editorial updates. • Re-organized the first few subsections of the “Overview” section. • Added ECSM to the block diagram. • Added information on the REACM, SIU, and ECS modules to the “Block summary” section. • Added DATA[0:15] to V_{DDE5} in the “signal properties” table. • Updated VSTBY parameters in the “Power/ground segmentation” table. • Updated the parameter symbols and classifications throughout the document. • Updated footnote instances in the “Absolute maximum ratings” table. • Removed I_{MAXA} footnote in the “Absolute Maximum Ratings” table. • Updated the format of the “EMI (electromagnetic interference) characteristics” table. • Removed the footnote on V_{DDREG} in the “Power management control (PMC) and power on reset (POR) electrical specifications” table. • Updated values for Vbg, Idd3p3, Por3.3V_r, Por3.3V_f, Por5V_r, and Por5V_f in the “PMC electrical characteristics” table. • Updated “Bandgap reference supply voltage variation” in the “PMC Electrical Characteristics” table. • Updated $V_{CE_{SAT}}$ and V_{BE} in the “Recommended power transistors” operating characteristics” table. • Updated $V_{IH_{LS}}$ in the “DC electrical specifications” table. • Updated the $V_{OH_{LS}}$ min value in the “DC electrical specifications” table. • Updated I_{DDSTBY} and $I_{DDSTBY150}$ in the “DC electrical specifications” table. • Updated the $I_{DDA}/I_{REF}/I_{DDREG}$ max value in the “DC electrical specifications” table. • Updated I_{ACT_F}, $I_{ACT_MV_PU}$, $I_{ACT_MV_PD}$, R_{PUPD5K}, $R_{PUPDMTCH}$, and footnotes in the “DC electrical specifications” table. • Updated Medium pad type I_{DD33} values in the “I/O pad V_{RC33} average I_{DDE} specifications” table. • Updated values for V_{OD} in the “DSPI LVDS pad specification” table. • Removed the footnotes from the “DSPI LVDS pad specifications” table. • Removed the redundant “XTAL Load Capacitance” parameter instance from the “PLLMRFM electrical specifications” table. • Updated footnotes in the “PLLMRFM electrical specifications” table. • Updated values for OFFNC and GAINNC in the “eQADC conversion specifications (operating)” table. • Added $DIFF_{max}$, $DIFF_{max2}$, $DIFF_{max4}$, and $DIFF_{cmv}$ parameters to the “eQADC conversion specifications (operating)” table. • Added the maximum operating frequency values in the “Cutoff frequency for additional SRAM wait state” table. • Updated multiple entries in the “APC, RWSC, WWSC settings vs. frequency of operation” table. • Removed footnote in the “APC, RWSC, WWSC settings vs. frequency of operation” table. • Changed the voltage in the “Pad AC specifications” table title from 4.5 V to 5.0 V. • Added the maximum LH/HL output delay values for pad type MultiV in the “Pad AC specifications ($V_{DDE} = 3.3$ V)” table.
Rev. 6	—	<ul style="list-style-type: none"> • Rev. 6 not published.

Table 53. Revision history (continued)

Revision	Date	Substantive changes
Rev. 7	01/2012	<ul style="list-style-type: none"> • Minor editorial changes. • In MPC5644A feature list, moved “24 unified channels” after “1 x eMIOS”. • In Table 3MPC5644A signal properties/Column “Name” updated the following rows: DSPI_D_SCK /GPIO [98] -Changed “-” to CS[2] DSPI_D_SIN /GPIO[99] -Changed “-” to CS[3]. • In Table 11Thermal characteristics for 324-pin TEPBGA/ Column “Value” added conditional text. • In Table 21DC electrical specifications made the following changes: <ul style="list-style-type: none"> -For the value “V_{OL_S}” parameter changed from “Slow/ medium/multi-voltage pad I/O output low voltage” to “Slow/medium pad I/O output low voltage”. -Added a new row for “I_{DDSTBY27}”. -For row “I_{DDSTBY}(operating current 0.95 -1.2V)” added max value “100” and changed typ value from “125” to “35”. -For row “I_{DDSTBY} (operating current 2 - 5.5V)” added max value “110” and changed typ value from “135” to “45”. -For symbol “I_{DDSTBY 150}(operating current 0.95 -1.2V)” added max value “2000”, changed typ value from “1050” to “790”, C cell changed from “T” to “P” and for symbol “I_{DDSTBY} (operating current 2 - 5.5V)” added max value “2000”, changed typ value from “1050” to “760”, C cell changed from “T” to “P”. -Removed note 9 and note 10 (Characterization based capability) from symbol “V_{OL_HS}”. • Split Table 28eQADC conversion specifications (operating)into Table 29eQADC single ended conversion specifications (operating) and Table 30eQADC differential ended conversion specifications (operating). • In Table 30 eQADC differential ended conversion specifications (operating)made the following changes: <ul style="list-style-type: none"> -Added the note of DIFF_{cmv} on all of the DIFF specs. -Min value changed from (VRH-VRL)/2-5% to (VRH+VRL)/2-5 % and max value changed from (VRH-VRL)/2+5 % to (VRH+VRL)/2+5 %for DIFFcmv. • In Table 31 Cutoff frequency for additional SRAM wait statemade the following changes: <ul style="list-style-type: none"> -Added note “Max frequencies including 2% PLL FM”. -Max operating frequency changed from “96” to “98” and “150” to “153”. • In Section 3.13, “Configuring SRAM wait states”, changed text from “MPC5644A Microcontroller Reference Manual “ to “device reference manual”. • In Table 32APC, RWSC, WWSC settings vs. frequency of operation: <ul style="list-style-type: none"> - Added note for “Max Flash Operating Frequency(MHz). - Changed values from 30, 60,120, 150 to 20,61,123, 153 respectively in Max Flash Operating Frequency (MHz). • In Table 33,aFlash program and erase specifications added two parameter “T_{psrt}” and “T_{esrt}”. • In Table 41External Bus Interface maximum operating frequency, replaced the <= symbol in notes with ≤ • Added note “Refer to table DSPI timing for the numbers” in all the figures under Section 3.17.8, “DSPI timing”. • In Table 52Orderable part number summary, changed LPGA208 to MAPBGA and changed all packages to 123XXXX format.

Table 53. Revision history (continued)

Revision	Date	Substantive changes
Rev. 7 (cont.)	01/12	<ul style="list-style-type: none">• Added Table 17 MPC5644A External network specification.• Updated Figure 8.• Changed External Network Parameter Ce min value to “3*2.35μF+5μF” from “2*2.35μF+5μF” in Table 17 MPC5644A External network specification.• Changed Trans. Line (differential Zo) unit to Ω from W in Table 25 DSPI LVDS pad specification.

How to Reach Us:

Home Page:

www.freescale.com

Web Support:

<http://www.freescale.com/support>

USA/Europe or Locations Not Listed:

Freescale Semiconductor, Inc.
Technical Information Center, EL516
2100 East Elliot Road
Tempe, Arizona 85284
1-800-521-6274 or +1-480-768-2130
www.freescale.com/support

Europe, Middle East, and Africa:

Freescale Halbleiter Deutschland GmbH
Technical Information Center
Schatzbogen 7
81829 Muenchen, Germany
+44 1296 380 456 (English)
+46 8 52200080 (English)
+49 89 92103 559 (German)
+33 1 69 35 48 48 (French)
www.freescale.com/support

Japan:

Freescale Semiconductor Japan Ltd.
Headquarters
ARCO Tower 15F
1-8-1, Shimo-Meguro, Meguro-ku,
Tokyo 153-0064
Japan
0120 191014 or +81 3 5437 9125
support.japan@freescale.com

Asia/Pacific:

Freescale Semiconductor China Ltd.
Exchange Building 23F
No. 118 Jianguo Road
Chaoyang District
Beijing 100022
China
+86 10 5879 8000
support.asia@freescale.com

Freescale Semiconductor Literature Distribution Center
P.O. Box 5405
Denver, Colorado 80217
1-800-441-2447 or +1-303-675-2140
Fax: +1-303-675-2150
LDCForFreescaleSemiconductor@hibbertgroup.com

Document Number: MPC5644A

Rev. 7

Jan 2012

Information in this document is provided solely to enable system and software implementers to use Freescale Semiconductor products. There are no express or implied copyright licenses granted hereunder to design or fabricate any integrated circuits or integrated circuits based on the information in this document.

Freescale Semiconductor reserves the right to make changes without further notice to any products herein. Freescale Semiconductor makes no warranty, representation or guarantee regarding the suitability of its products for any particular purpose, nor does Freescale Semiconductor assume any liability arising out of the application or use of any product or circuit, and specifically disclaims any and all liability, including without limitation consequential or incidental damages. "Typical" parameters that may be provided in Freescale Semiconductor data sheets and/or specifications can and do vary in different applications and actual performance may vary over time. All operating parameters, including "Typicals", must be validated for each customer application by customer's technical experts. Freescale Semiconductor does not convey any license under its patent rights nor the rights of others. Freescale Semiconductor products are not designed, intended, or authorized for use as components in systems intended for surgical implant into the body, or other applications intended to support or sustain life, or for any other application in which the failure of the Freescale Semiconductor product could create a situation where personal injury or death may occur. Should Buyer purchase or use Freescale Semiconductor products for any such unintended or unauthorized application, Buyer shall indemnify and hold Freescale Semiconductor and its officers, employees, subsidiaries, affiliates, and distributors harmless against all claims, costs, damages, and expenses, and reasonable attorney fees arising out of, directly or indirectly, any claim of personal injury or death associated with such unintended or unauthorized use, even if such claim alleges that Freescale Semiconductor was negligent regarding the design or manufacture of the part.

RoHS-compliant and/or Pb-free versions of Freescale products have the functionality and electrical characteristics as their non-RoHS-compliant and/or non-Pb-free counterparts. For further information, see <http://www.freescale.com> or contact your Freescale sales representative.

For information on Freescale's Environmental Products program, go to <http://www.freescale.com/epp>.

Freescale™ and the Freescale logo are trademarks of Freescale Semiconductor, Inc. All other product or service names are the property of their respective owners.
© Freescale Semiconductor, Inc. 2009–2012. All rights reserved.



X-ON Electronics

Largest Supplier of Electrical and Electronic Components

Click to view similar products for [32-bit Microcontrollers - MCU category](#):

Click to view products by [Freescale manufacturer](#):

Other Similar products are found below :

[MB91101APFR-G-JNE1](#) [MB91F469GBP-B-GSE1](#) [MB91F522KWBPMC-GSE2](#) [MB91F526LKCPMC-GSE2](#) [MB91F575BHSPMC-GSE1](#)
[MB91F594BSPMC-GSE1](#) [MCF51AC256AVFUE](#) [MCF51AC256AVLKE](#) [MCF5282CVF66](#) [PIC32MX120F032B-50I/SS](#)
[SPC560C50L3B4E0X](#) [SPC560P40L1CEFBR](#) [PIC32MX120F032B-50I/ML](#) [MB91F464AAPMC-GSE2](#) [MB91F524FSCPMC-GSE2](#)
[MB91F53BCEQ-GSAE2](#) [MB91F577BHSPMC-GSE1](#) [MB91F59BCPB-GSE1](#) [SPC5604EEF2MLH](#) [MCF5282CVM66](#) [MCF51AC256BVLKE](#)
[MB91F579CHSPMC1-GSE1](#) [MB91F528UWCEQ-GSE2](#) [MB91F528USCPMC-GSE2](#) [R5F104LJAFBV0](#) [SPC5606BK0VLQ6](#)
[R5S726B0D216FP#V0](#) [SPC564A70L7CFAY](#) [TC299TX128F300NBCKXUMA1](#) [SPC58EC80E1Q0C0Y](#) [R5S72691W266FP#V0](#)
[TC275T64F200WCAKXUMA1](#) [PIC32MM0016GPL028-I/SS](#) [MB91F592BHSPMC-GSE1](#) [SPC5746CSK1MMH6](#) [SPC5777MK0MVA8](#)
[R5S72630P200FP](#) [R5F72855D100FP#U2](#) [MB91F069BSCPMC1-GSE1](#) [SPC564A80AVB324](#) [SPC5777MK0MVU8](#) [MB91F469GBP-B-GS-](#)
[N2](#) [R8A77210C133BGV](#) [MB91F594BPMC-GSE1](#) [UPD70F3623GBA-GAH-QS-AX](#) [MB91243PFV-GS-136E1](#) [SPC5741PK1AMLQ8](#)
[AT32UC3A4128S-C1UT](#) [PIC32MX130F064D-50I/PT](#) [AT32UC3A4256-C1UT](#)