

Specification		
Part Number:		
Version:		
Date:		
Revision		
1.0	FIRST ISSUE	2015.01.20



Contents

General Description	4
1. Block Diagram	5
2. Outline dimension	6
3. Input Terminal Pin Assignment	7
4. LCD Optical Characteristics	9
5. Electrical Characteristics	12
6. AC Characteristic	14
7. LCD Module Out-Going Quality Level	21
8 Reliability Test Result	31
9. Cautions and Handling Precautions	32
10. Packing	33



Midas Active Matrix Display Part Number System

MC T 057 A 6 * W 320240 L M L * *
1 2 3 4 5 6 7 8 9 10 11 12 13

- 1 = **MC:** Midas Components
- 2 = **T:** TFTA: Active Matrix OLED **M:** Monitor
- 3 = **Size**
- 4 = **Series**
- 5 = **Viewing Angle:** 6: 6 O'clock 12: 12 O'clock O: All Round Viewing Angle
- 6 = **Blank:** No Touch **T:** Resistive Touchscreen **C:** Capacitive Touchscreen
- 7 = **Operating Temp Range:** **S:** 0+50Deg C **B:** -20+60Deg C
 W: -20+70Deg C **E:** -30+85Deg C
 X: -30+80Deg C
- 8 = **No of Pixels**
- 9 = **Orientation:** **P:** Portrait **L:** Landscape
- 10 = **Mode:** **R:** Reflective **M:** Transmissive **T:** Transflective
S: Sunlight Readable (Transmissive) **W:** White on Black (Monochrome)
- 11 = **Backlight:** **Blank:** None **L:** LED **C:** CCFL
- 12 = **Blank:** No Module/board **C:** Controller board module (E-Tech)
- 13 = **Blank:** None **OB:** Optically Bonded **IPS:** In-plane switching



General Description

* Description

This is a color active matrix TFT (Thin Film Transistor) LCD (liquid crystal display) that uses amorphous silicon TFT as a switching device. This model is composed of a Transmissive type TFT LCD Panel, driver circuit, back-light unit. The resolution of a 2.8" TFT-LCD contains 240x320 pixels, and can display up to 65K/262K colors.

* Features

-Low Input Voltage: 3.3V(TYP)

-Display Colors of TFT LCD: 65K/262K colors

-RGB Interface: 8/9/16/18BIT 8080 MCU interface;3/4-wire serial interface;16/18BIT RGB

General Information Items	Specification	Unit	Note
	Main Panel		
Display area(AA)	43.20(H)*57.60 (V) (2.8inch)	mm -	
Driver element	TFT active matrix	-	-
Display colors	65K/262k	colors	-
Number of pixels	240(RGB)*320	dots	-
Pixel arrangement	RGB vertical stripe	-	-
Pixel pitch	0.153(H)*0.153(V)	mm	-
Viewing angle	ALL	o'clock -	
Controller IC	ST7789V	-	-
Display mode	Transmissive/ Normally black	-	-
Operating temperature	-20~+70	°C	-
Storage temperature	-30~+80	°C	-

* Mechanical Information

Item		Min.	Typ.	Max.	Unit	Note
Module size	Horizontal(H)		50.50		mm	-
	Vertical(V)		69.70		mm	-
	Depth(D)		2.60		mm	-
Weight		TBD			g	-

1. Block Diagram

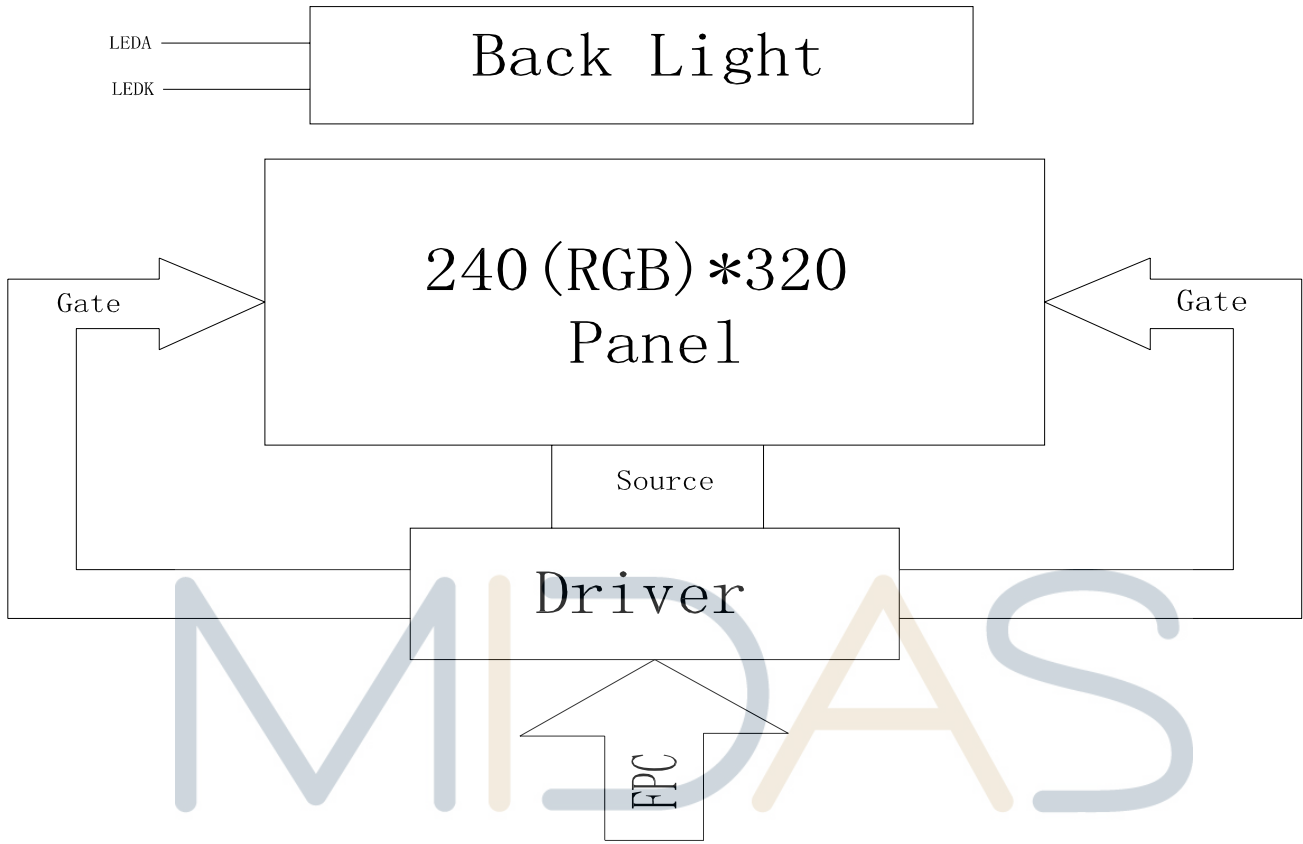

design • manufacture • supply



2. Outline dimension

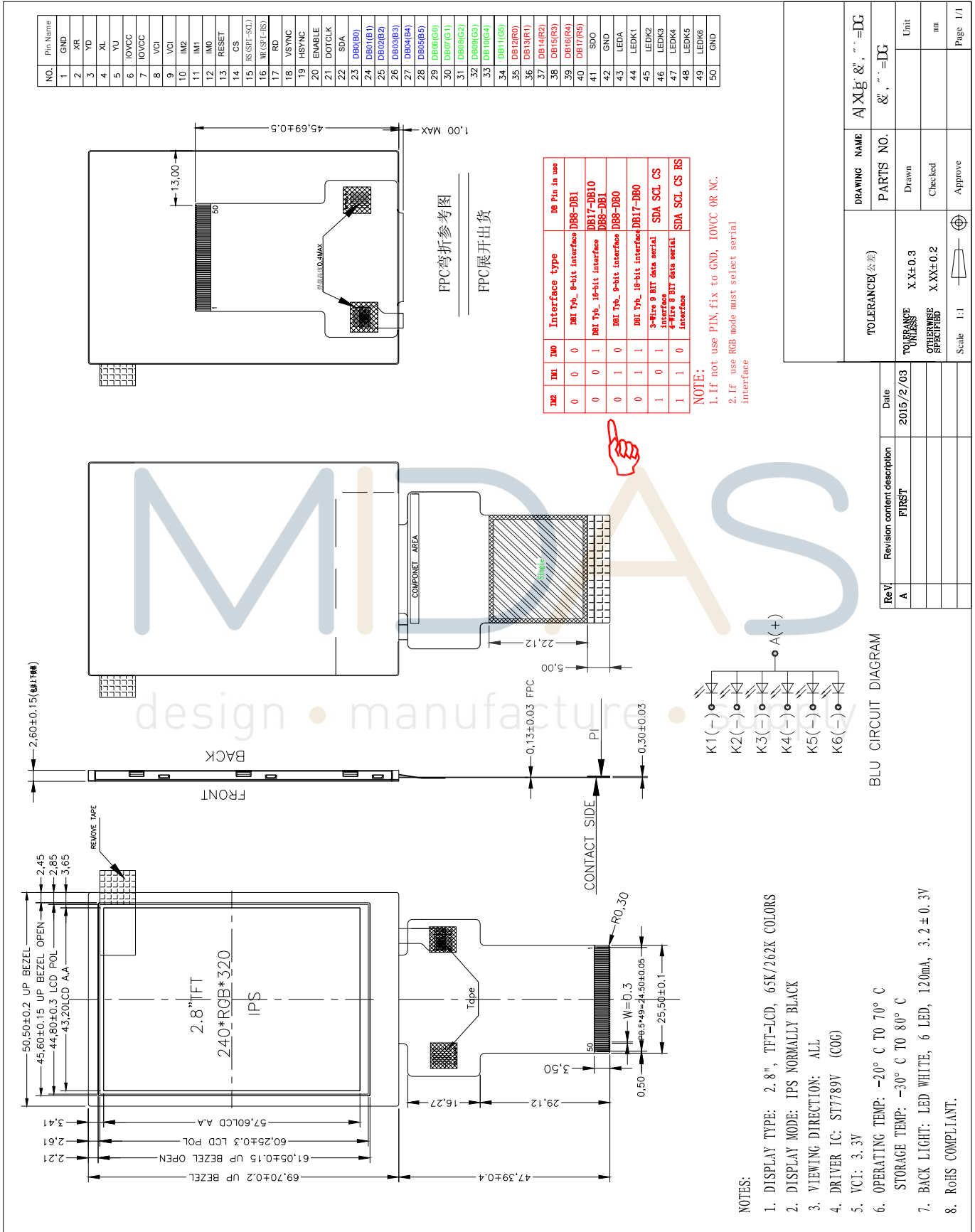

3. Input terminal Pin Assignment

NO.	SYMBOL	DISCRIPTION	I/O
1	GND	Ground.	P
2	XR(NC)	Touch panel Right Glass Terminal	A/D
3	YD(NC)	Touch panel Bottom Film Terminal	A/D
4	XL(NC)	Touch panel LIFT Glass Terminal	A/D
5	YU(NC)	Touch panel Top Film Terminal	A/D
6	IOVCC	Supply voltage for IO (1.8-3.3V).	P
7	IOVCC	Supply voltage for IO (1.8-3.3V).	P
8	VCI	Supply voltage (3.3V).	P
9	VCI	Supply voltage (3.3V).	P
10	IM2	MPU Parallel interface bus and serial interface select If use RGB Interface must select serial interface. Fix this pin at IOVCC and GND.	I
11	M1		
12	IM0		
13	RESET	This signal will reset the device and must be applied to properly initialize the chip.	I
14	CS	Chip select input pin ("Low" enable). Fix this pin at IOVCC or GND when not in use.	I
15	RS(SPI-SCL)	This pin is used to select "Data or Command" in the parallel interface. When D/CX = '1', data is selected. When D/CX = '0', command is selected. This pin is used serial interface clock in 3-wire 9-bit / 4-wire 8-bit serial data interface. Fix this pin at IOVCC or GND when not in use.	I
16	WR(SPI-RS)	The data is applied on the rising edge of the SCL signal. Fix this pin at IOVCC or GND when not in use.	I
17	RD	Serves as a read signal and MCU read data at the rising edge. Fix this pin at IOVCC or GND when not in use	I

18	VSYNC	Frame synchronizing signal for RGB interface operation. Fix this pin at IOVCC or GND when not in use.	I
19	HSY NC	Line synchronizing signal for RGB interface operation. Fix this pin at IOVCC or GND when not in use.	I
20	ENABLE	Data enable signal for RGB interface operation. Fix this pin at IOVCC or GND when not in use.	I
21	DOTCLK	Dot clock signal for RGB interface operation. Fix this pin at IOVCC or GND when not in use.	I
22	SDA	Serial input signal. The data is applied on the rising edge of the SCL signal. If not used, fix this pin at IOVCC or GND.	I
23-40	DB0-DB7	Data bus. If not used pin, fix this pin to GND.	I/O
41	SDO	SPI interface output pin. -The data is output on the falling edge of the SCL signal. -If not used, let this pin open.	O
42	GND	Ground.	P
43	LEDA	Anode pin of backlight	P
44	LEDK1	Cathode pin OF backlight	P
45	LEDK2	Cathode pin OF backlight	P
46	LEDK3	Cathode pin OF backlight	P
47	LEDK4	Cathode pin OF backlight	P
48	LEDK5	Cathode pin OF backlight	P
49	LEDK6	Cathode pin OF backlight	P
50	GND	Ground.	P



4. LCD Optical Characteristics

4.1 Optical specification

Item	Symbol	Condition	Min.	Typ.	Max.	Unit	Note
Transmittance (with Polarizer)	T (%)	$\Theta=0$ Normal viewing angle	—	(4.63)	—	%	Measuring with Polarizer , Reference Only
Transmittance (without Polarizer)	T (%)		—	(17.5)	—	%	
Contrast Ratio	CR		600	800	—	—	(1)(2)
Response Time	$T_R + T_F$		—	30	40	msec	(1)(3)
Color gamut	(%)		—	60	—	%	C-light
Color chromaticity (CIE1931)	White	W_x	(0.288)	(0.308)	(0.328)	—	(1)(4) CF glass
		W_y	(0.310)	(0.330)	(0.350)	—	
	Red	R_x	(0.621)	(0.641)	(0.661)	—	
		R_y	(0.317)	(0.337)	(0.357)	—	
	Green	G_x	(0.254)	(0.274)	(0.294)	—	
		G_y	(0.540)	(0.560)	(0.580)	—	
	Blue	B_x	(0.121)	(0.141)	(0.161)	—	
		B_y	(0.093)	(0.113)	(0.133)	—	
Viewing angle	Hor.	Θ_L	—	80	—	—	(1)(4) Measuring with Polarizer , Reference Only
		Θ_R	—	80	—		
	Ver.	Θ_U	—	80	—		
		Θ_D	—	80	—		
Optima View Direction	Free						(5)

4.2 Measuring Condition

- Measuring surrounding: dark room
- Ambient temperature: $25\pm 2^{\circ}\text{C}$
- 15min. warm-up time.

4.3 Measuring Equipment

- FPM520 of Midas, which utilized SR-3 for Chromaticity and BM-5A for other optical characteristics.

Note (1) Definition of Viewing Angle:

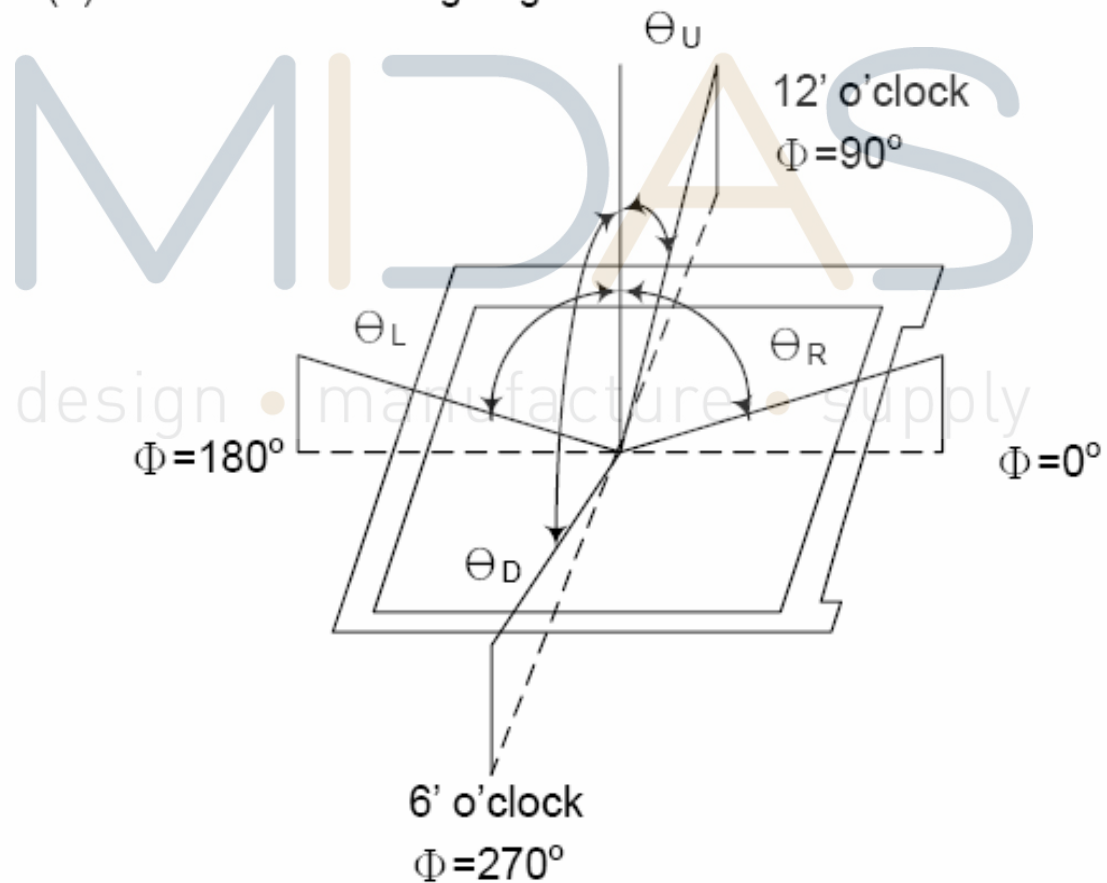

Note (2) Definition of Contrast Ratio (CR) :
measured at the center point of panel

$$CR = \frac{\text{Luminance with all pixels white}}{\text{Luminance with all pixels black}}$$

Note (3) Definition of Response Time : Sum of T_R and T_F

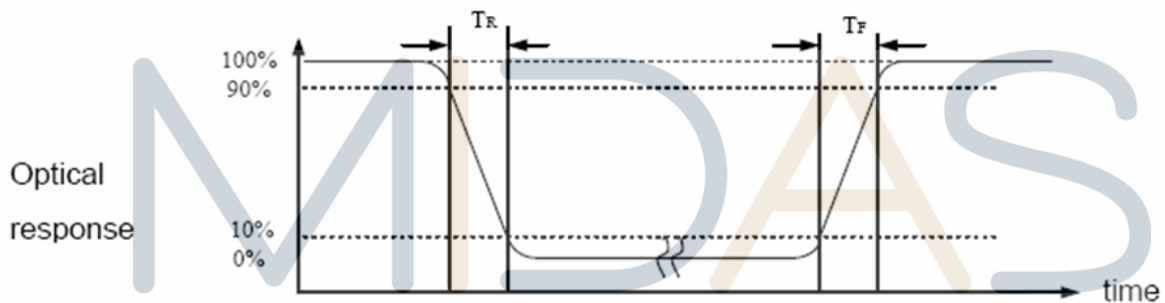
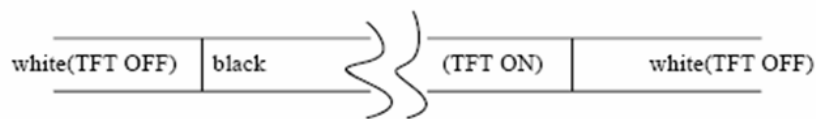

design • manufacture • supply



5. Electrical Characteristics

5.1 Absolute Maximum Rating (Ta=25 VSS=0V)

Characteristics	Symbol	Min.	Max.	Unit
Digital Supply Voltage	VDD -0.3		4.6	V
Digital interface supply Voltage	VDDIO	-0.3	4.6	V
Operating temperature	T _{OP} -20		+70	°C
Storage temperature	T _{ST} -30		+80	°C

5.2 DC Electrical Characteristics

Characteristics	Symbol	Min.	Typ.	Max.	Unit	Note
Digital Supply Voltage	VDD 2.4		3.3	4.2	V	
Digital interface supply Voltage	VDDIO 1.65		3.3	4.2	V	
Normal mode Current consumption	IDD --		8	--	mA	
Level input voltage	V _{IH} 0.7V _{DDIO}			VDDIO	V	
	V _{IL} GND			0.3V _{DDIO}	V	
Level output voltage	V _{OH} 0.8V _{DDIO}			VDDIO	V	
	V _{OL} GND			0.2V _{DDIO}	V	

5.3 LED Backlight Characteristics

The back-light system is edge-lighting type with 6 chips White LED

Item	Symbol	Min.	Typ.	Max.	Unit	Note
Forward Current	I _F 90		120	--	mA	
Forward Voltage	V _F --		3.2	--	V	
LCM Luminance	L _V 450		500	--	cd/m ²	IF=120mA

LED life time	Hr	50000	--	--	Hour	Note1,2
Uniformity	AVg	80	--	--	%	

Note (1) LED life time (Hr) can be defined as the time in which it continues to operate under the condition:

$T_a=25\pm 3\text{ }^\circ\text{C}$, typical IL value indicated in the above table until the brightness becomes less than 50%.

Note (2) The "LED life time" is defined as the module brightness decrease to 50% original brightness at

$T_a=25\text{ }^\circ\text{C}$ and $I_L=120\text{mA}$. The LED lifetime could be decreased if operating I_L is larger than 120mA.

The constant current driving method is suggested.

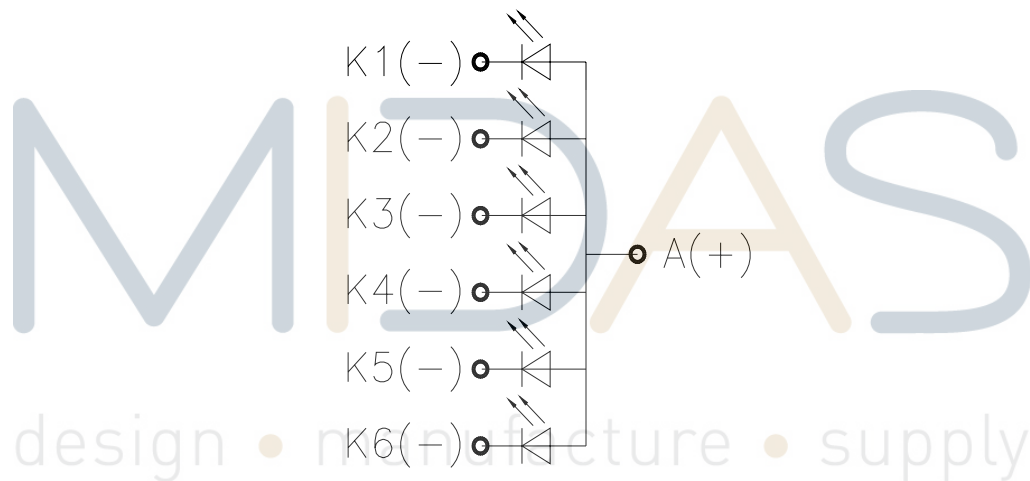

BLU CIRCUIT DIAGRAM



6. AC Characteristic

6.1 8080 Series MCU Parallel Interface Timing Characteristics: 18/16/9/8-bit Bus

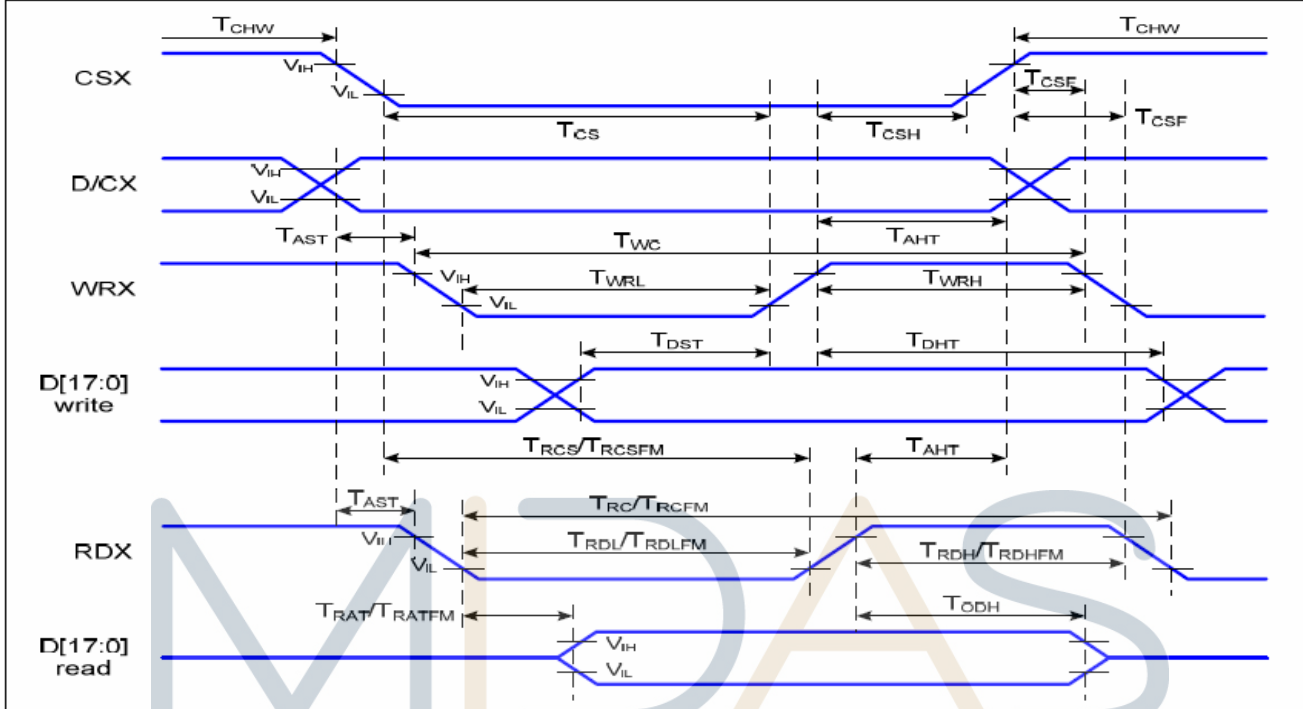

VDDI=1.65 to 3.3V, VDD=2.4 to 3.3V, AGND=DGND=0V, Ta= -30 to 70 °C

Signal	Symbol	Parameter	Min	Max	Unit	Description
D/CX	T _{AST}	Address setup time	0		ns	-
	T _{AHT}	Address hold time (Write/Read)	10		ns	-
CSX	T _{CHW}	Chip select "H" pulse width	0		ns	-
	T _{CS}	Chip select setup time (Write)	15		ns	-
	T _{RCS}	Chip select setup time (Read ID)	45		ns	-
	T _{RCSFM}	Chip select setup time (Read FM)	355		ns	-
	T _{CSF}	Chip select wait time (Write/Read)	10		ns	-
	T _{CSH}	Chip select hold time	10		ns	-
WRX	T _{WC}	Write cycle	66		ns	-
	T _{WRH}	Control pulse "H" duration	15		ns	-
	T _{WRL}	Control pulse "L" duration	15		ns	-
RDX (ID)	T _{RC}	Read cycle (ID)	160		ns	When read ID data
	T _{RDH}	Control pulse "H" duration (ID)	90		ns	
	T _{RDL}	Control pulse "L" duration (ID)	45		ns	
RDX (FM)	T _{RCFM}	Read cycle (FM)	450		ns	When read from frame memory
	T _{RDHF}	Control pulse "H" duration (FM)	90		ns	
	T _{RDLFM}	Control pulse "L" duration (FM)	355		ns	
D[17:0]	T _{DST}	Data setup time	10		ns	For CL=30pF

T_{DHT}	Data hold time	10		ns
T_{RAT}	Read access time (ID)		40	ns
T_{RATFM}	Read access time (FM)		340	ns
T_{ODH}	Output disable time	20	80	ns

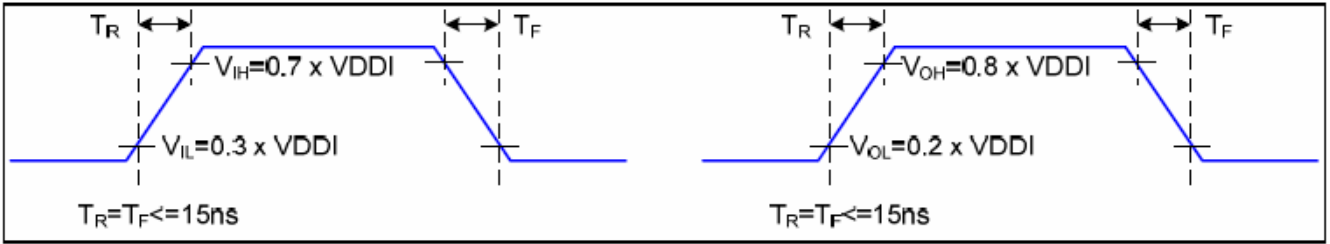

Figure 2 Rising and Falling Timing for I/O Signal

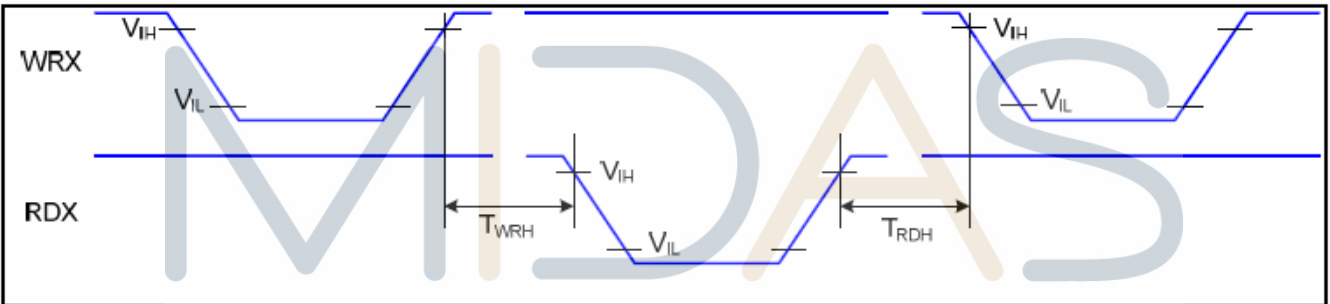
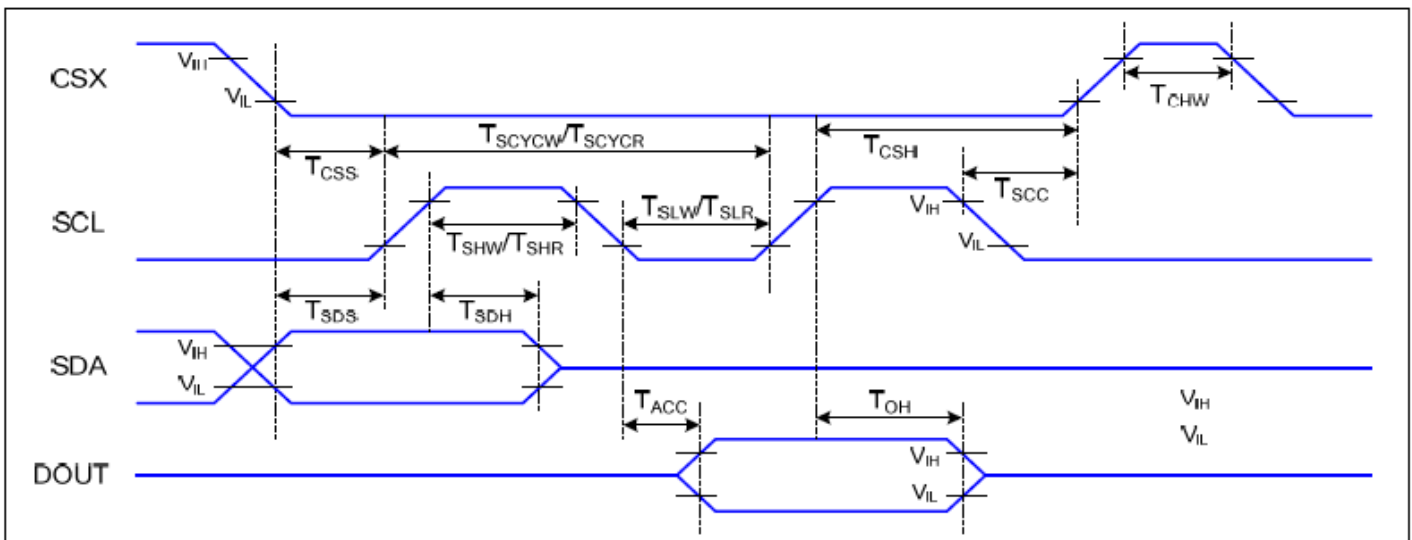

Figure 3 Write-to-Read and Read-to-Write Timing

Note: The rising time and falling time (T_r , T_f) of input signal and fall time are specified at 15 ns or less. Logic high and low levels are specified as 30% and 70% of VDDI for Input signals.

6.2 Display Serial Interface Timing Characteristics (3-line SPI system)



VDDI=1.65 to 3.3V, VDD=2.4 to 3.3V, AGND=DGND=0V, Ta=-30 to 70 °C

Signal	Symbol	Parameter	Min	Max	Unit	Description
CSX	T_{CSS}	Chip select setup time (write)	15		ns	
	T_{CSH}	Chip select hold time (write)	15		ns	
	T_{CSS}	Chip select setup time (read)	60		ns	
	T_{SCC}	Chip select hold time (read)	65		ns	
	T_{CHW}	Chip select "H" pulse width	40		ns	
SCL	T_{SCYCW}	Serial clock cycle (Write)	66		ns	
	T_{SHW}	SCL "H" pulse width (Write)	15		ns	
	T_{SLW}	SCL "L" pulse width (Write)	15		ns	
	T_{SCYCR}	Serial clock cycle (Read)	150		ns	
	T_{SHR}	SCL "H" pulse width (Read)	60		ns	
	T_{SLR}	SCL "L" pulse width (Read)	60		ns	
SDA (DIN)	T_{SDS}	Data setup time	10		ns	
	T_{SDH}	Data hold time	10		ns	
DOUT	T_{ACC}	Access time	10	50	ns	For maximum CL=30pF
	T_{OH}	Output disable time	15	50	ns	For minimum CL=8pF

6.3 Display Serial Interface Timing Characteristics (4-line SPI system)

design • manufacture • supply

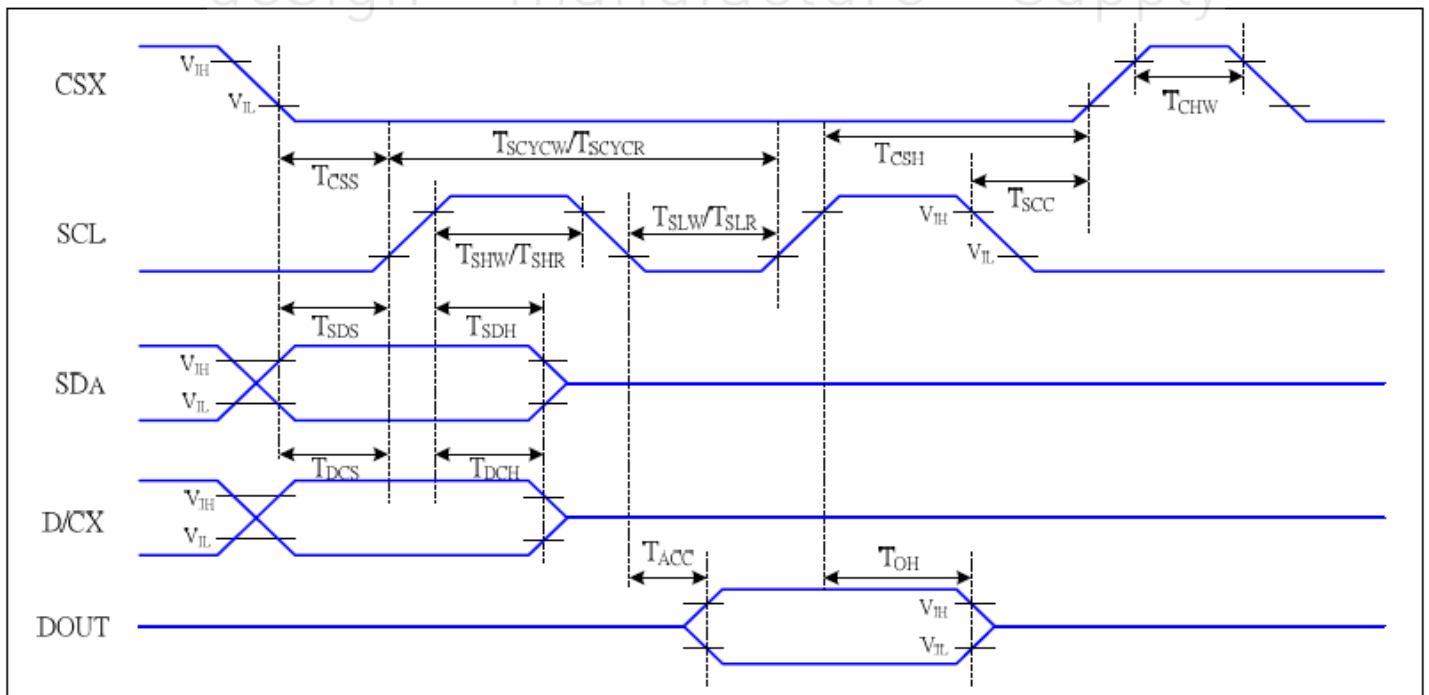

VDDI=1.65 to 3.3V, VDD=2.4 to 3.3V, AGND=DGND=0V, Ta=-30 to 70 °C

Signal	Symbol	Parameter	MIN	MAX	Unit	Description
CSX	T_{CSS}	Chip select setup time (write)	15		ns	
	T_{CSH}	Chip select hold time (write)	15		ns	
	T_{CSS}	Chip select setup time (read)	60		ns	
	T_{SCC}	Chip select hold time (read)	65		ns	
	T_{CHW}	Chip select "H" pulse width	40		ns	
SCL	T_{SCYCW}	Serial clock cycle (Write)	66		ns	-write command & data ram
	T_{SHW}	SCL "H" pulse width (Write)	15		ns	
	T_{SLW}	SCL "L" pulse width (Write)	15		ns	
	T_{SCYCR}	Serial clock cycle (Read)	150		ns	-read command & data ram
	T_{SHR}	SCL "H" pulse width (Read)	60		ns	
	T_{SLR}	SCL "L" pulse width (Read)	60		ns	
D/CX	T_{DCS}	D/CX setup time	10		ns	
	T_{DCH}	D/CX hold time	10		ns	
SDA (DIN)	T_{SDS}	Data setup time	10		ns	
	T_{SDH}	Data hold time	10		ns	
DOUT	T_{ACC}	Access time	10	50	ns	For maximum CL=30pF
	T_{OH}	Output disable time	15	50	ns	For minimum CL=8pF

6.4 Parallel RGB Interface Timing Characteristics

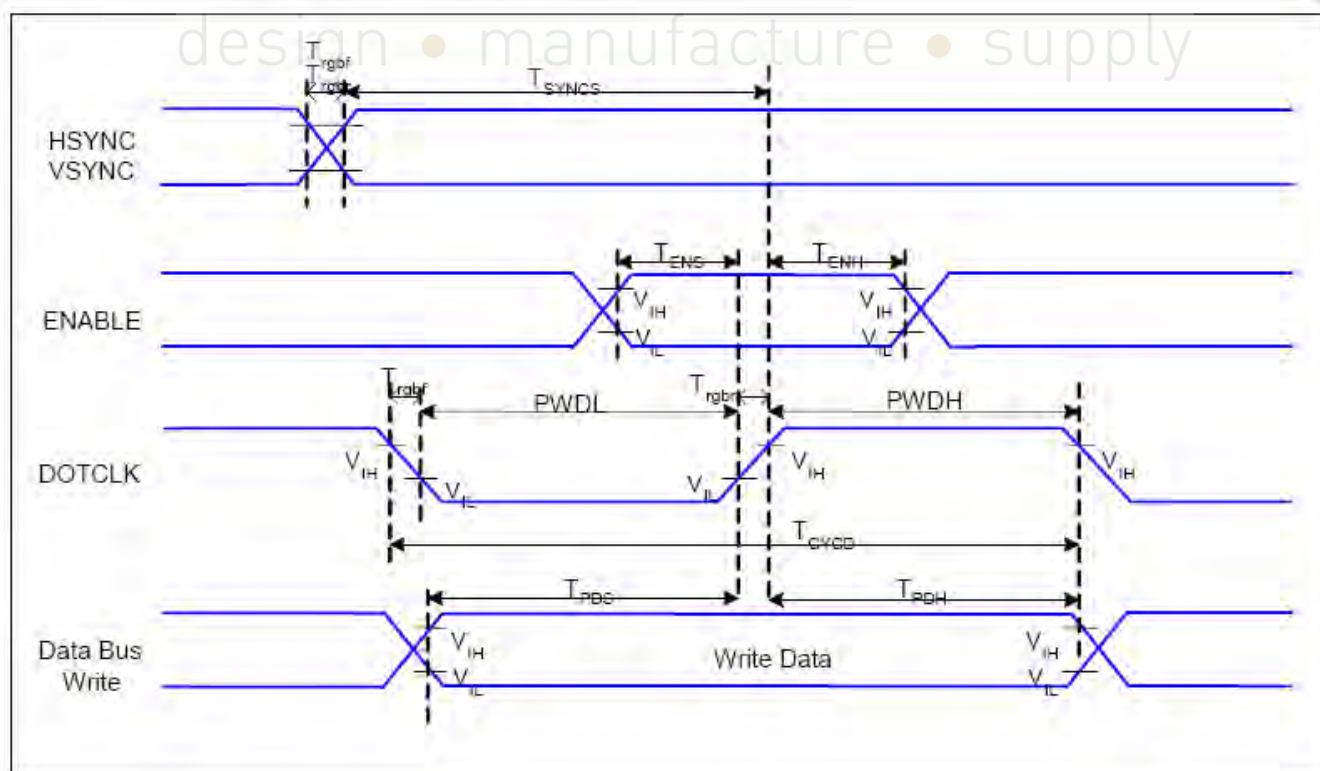

VDDI=1.65 to 3.3V, VDD=2.4 to 3.3V, AGND=DGND=0V, Ta=-30 ~ 70 °C

Signal	Symbol	Parameter	MIN	MAX	Unit	Description
HSYNC, VSYNC	T _{SYNCS}	VSYNC, HSYNC Setup Time	30	-	ns	
ENABLE	T _{ENS}	Enable Setup Time	25	-	ns	
	T _{ENH}	Enable Hold Time	25	-	ns	
DOTCLK	PWDH	DOTCLK High-level Pulse Width	60	-	ns	
	PWDL	DOTCLK Low-level Pulse Width	60	-	ns	
	T _{CYCD}	DOTCLK Cycle Time	120	-	ns	
	Trghr, Trghf	DOTCLK Rise/Fall time	-	20	ns	
DB	T _{PDS}	PD Data Setup Time	50	-	ns	
	T _{PDH}	PD Data Hold Time	50	-	ns	

Parameters	Symbols	Condition	Min.	Typ.	Max.	Units
Horizontal Synchronization	Hsync		2	10	16	DOTCLK
Horizontal Back Porch	HBP		2	20	24	DOTCLK
Horizontal Address	HAdr		-	240	-	DOTCLK
Horizontal Front Porch	HFP		2	10	16	DOTCLK
Vertical Synchronization	Vsync		1	2	4	Line
Vertical Back Porch	VBP		1	2	-	Line
Vertical Address	VAdr		-	320	-	Line
Vertical Front Porch	VFP		3	4	-	Line

Setting Example: To set frame frequency to 70Hz:

Internal Clock

Internal Oscillation Clock: 615KHz

DIV[1:0] = 2'b0 (x 1/1)

RTN[4:0] = 5'h1b (27 clocks)

FP = 7'h2 (2 lines), BP = 7'h2 (2 lines), NL = 6'h27 (320 lines)

Frame Rate → 70.30Hz



DOTCLK

HSYNC = 10 CLK

HBP = 20 CLK

HFP=10 CLK

70Hz x (2 + 320 + 2) lines x (10 + 20 + 240 + 10) clocks = 6.35MHz

DOTCLK frequency = 6.35MHz

6.35 MHz / 615KHz = 10.32 □ Set PCDIV so that PCLK is divided by 10.

external fosc = 6.35 MHz / 10 = 635KHz

PCDIV = [6.35MHz / 635KHz) / 2] - 1 = 4

PCDIV[5:0] = 6'h04 (10 DOTCLK)

6.5 Reset Timing Characteristics

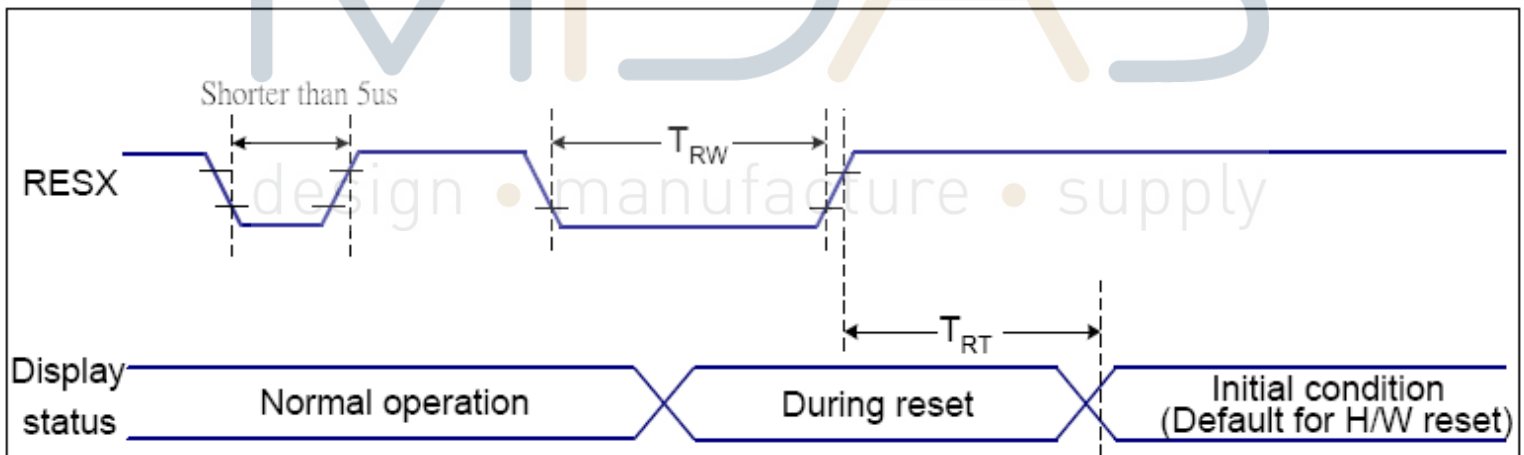

VDDI=1.65 to 3.3V, VDD=2.4 to 3.3V, AGND=DGND=0V, Ta=-30 ~ 70 °C

Related Pins	Symbol	Parameter	MIN	MAX	Unit
RESX	TRW	Reset pulse duration	10	-	µs
	TRT	Reset cancel	-	5 (Note 1, 5)	ms
				120 (Note 1, 6, 7)	ms

Notes:

1. The reset cancel includes also required time for loading ID bytes, VCOM setting and other settings from NVM (or similar device) to registers. This loading is done every time when there is HW reset cancel time (tRT) within 5 ms after a rising edge of RESX.

2. Spike due to an electrostatic discharge on RESX line does not cause irregular system reset according to the table below:

RESX Pulse	Action
Shorter than 5us	Reset Rejected
Longer than 9us	Reset
Between 5us and 9us	Reset starts

3. During the Resetting period, the display will be blanked (The display is entering blanking sequence, which maximum time is 120 ms, when Reset Starts in Sleep Out –mode. The display remains the blank state in Sleep In –mode.) and then return to Default condition for Hardware Reset.

4. Spike Rejection also applies during a valid reset pulse as shown below:

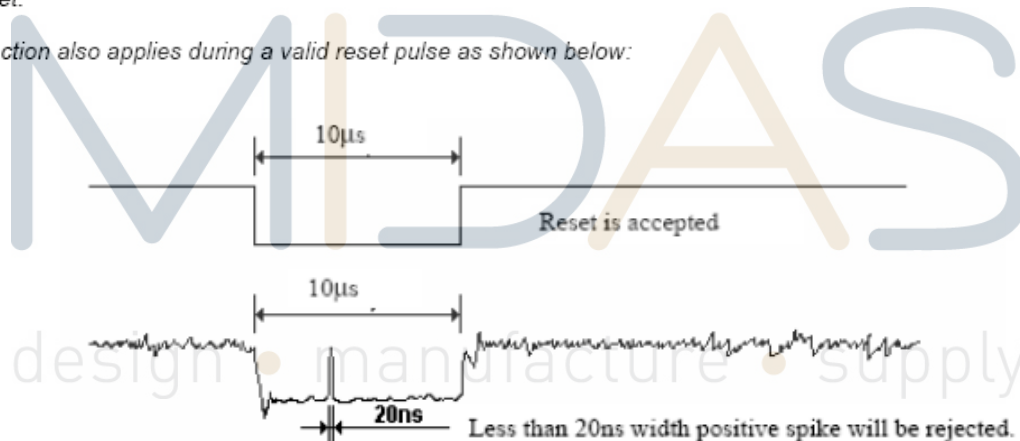

5. When Reset applied during Sleep In Mode.

6. When Reset applied during Sleep Out Mode.

7. It is necessary to wait 5msec after releasing RESX before sending commands. Also Sleep Out command cannot be sent for 120msec.



7. LCD Module Out-Going Quality Level

7.1 VISUAL & FUNCTION INSPECTION STANDARD

7.1.1 Inspection conditions

Inspection performed under the following conditions is recommended.

Temperature : $25\pm 5^{\circ}\text{C}$

Humidity : $65\%\pm 10\%\text{RH}$

Viewing Angle : Normal viewing Angle.

Illumination: Single fluorescent lamp (300 to 700Lux)

Viewing distance:30-50cm

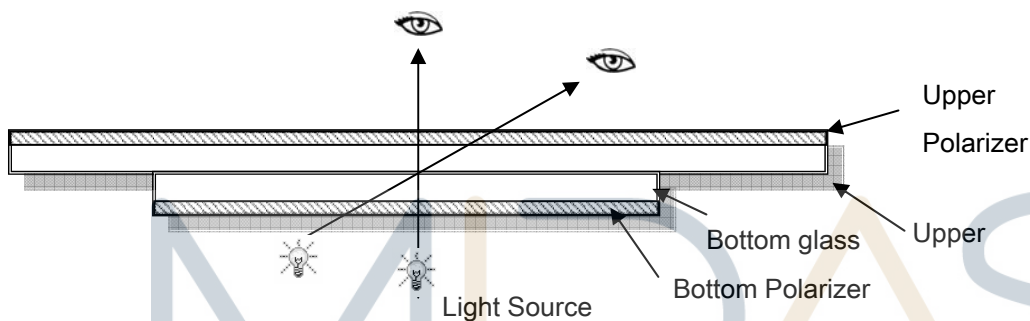

7.1.2 Definition

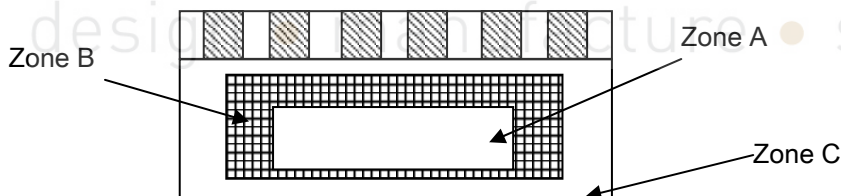

Zone A : Effective Viewing Area(Character or Digit can be seen)

Zone B : Viewing Area except Zone A

Zone C : Outside (Zone A+Zone B) which can not be seen after assembly by customer .)

Note:

As a general rule ,visual defects in Zone C can be ignored when it doesn't effect product function or appearance after assembly by customer.

7.1.3 Sampling Plan

According to GB/T 2828-2003 ; , normal inspection, Class II

AQL:



Major defect	Minor defect
0.65 1.5	

LCD: Liquid Crystal Display , TP: Touch Panel , LCM: Liquid Crystal Module

No	Items to be inspected	Criteria	Classification of defects
1	Functional defects	1) No display, Open or miss line 2) Display abnormally, Short 3) Backlight no lighting, abnormal lighting. 4) TP no function	Major
2	Missing	Missing component	
3	Outline dimension	Overall outline dimension beyond the drawing is not allowed	
4	Color tone	Color unevenness, refer to limited sample	Minor
5	Soldering appearance	Good soldering , Peeling off is not allowed.	
6	LCD/Polarizer/TP	Black/White spot/line, scratch, crack, etc.	

7.1.4 Criteria (Visual)

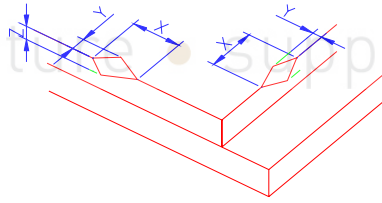
Number Items	Criteria(mm)						
1.0 LCD Crack/Broken	 <p>(1) The edge of LCD broken</p> <p>NOTE: X: Length Y: Width</p> <table border="1" data-bbox="842 1462 1374 1619"> <thead> <tr> <th>X Y</th> <th></th> <th>Z</th> </tr> </thead> <tbody> <tr> <td>≤3.0mm</td> <td><Inner border line of the seal</td> <td>≤T</td> </tr> </tbody> </table>	X Y		Z	≤3.0mm	<Inner border line of the seal	≤T
X Y		Z					
≤3.0mm	<Inner border line of the seal	≤T					

Z: Height
 L: Length of ITO,
 T: Height of LCD

(2) LCD corner broken

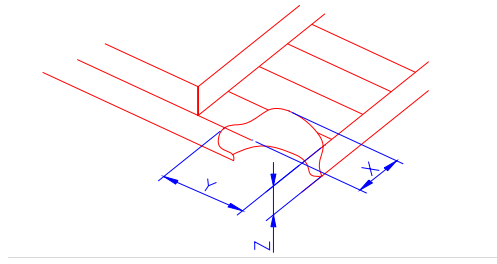

X Y		Z
≤3.0mm	≤L	≤T

(3) LCD crack

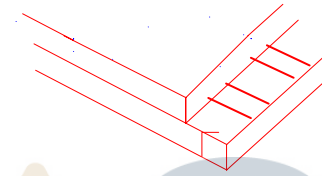

Crack
 Not allowed

MIDAS
 design • manufacture • supply



2.0

Spot defect

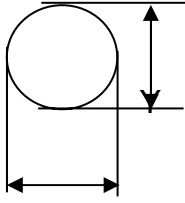

X

$\Phi=(X+Y)/2$

① light dot (LCD/TP/Polarizer black/white spot, light dot, pinhole, dent, stain)

Zone Size (mm)	Acceptable Qty		
	A	B	C
$\Phi \leq 0.10$	Ignore		
$0.10 < \Phi \leq 0.15$	3 (distance $\geq 10\text{mm}$)		
$0.15 < \Phi \leq 0.2$	1		
$0.2 < \Phi$	0		

② Dim spot (LCD/TP/Polarizer dim dot, light leakage, dark spot)

Zone Size (mm)	Acceptable Qty		
	A	B	C
$\Phi \leq 0.1$	Ignore		
$0.1 < \Phi \leq 0.2$	2 (distance $\geq 10\text{mm}$)		
$0.2 < \Phi \leq 0.3$	1		
$\Phi > 0.3$	0		

③ Polarizer accidented spot

Zone Size (mm)	Acceptable Qty		
	A	B	C
$\Phi \leq 0.2$	Ignore		
$0.2 < \Phi \leq 0.5$	2 (distance $\geq 10\text{mm}$)		
$\Phi > 0.5$	0		

Line defect
(LCD/TP
/Polarizer
black/white
line, scratch,
stain)

Width(mm) Length(mm)	Acceptable Qty		
	A	B	C
$\Phi \leq 0.03$	Ignore		
$0.03 < W \leq 0.05$ L	≤ 3.0 N	≤ 2	Ignore
$0.05 < W \leq 0.08$ L	≤ 2.0 N	≤ 2	
$0.08 < W$	Define as spot defect		



Items Criteria

(mm)

Spot defect

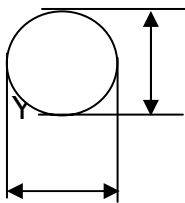

X

$\Phi=(X+Y)/2$

① light dot (LCD/TP/Polarizer black/white spot, light dot, pinhole, dent, stain)

Zone Size (mm)	Acceptable Qty		
	A	B	C
$\Phi \leq 0.10$ Ignore			Ignore
$0.10 < \Phi \leq 0.15$	3(distance $\geq 10\text{mm}$)		
$0.15 < \Phi \leq 0.2$	1		
$0.2 < \Phi$	0		

② Dim spot (LCD/TP/Polarizer dim dot, light leakage, dark spot)

Zone Size (mm)	Acceptable Qty		
	A	B	C
$\Phi \leq 0.1$ Ignore			Ignore
$0.1 < \Phi \leq 0.2$	2(distance $\geq 10\text{mm}$)		
$0.2 < \Phi \leq 0.3$	1		
$\Phi > 0.3$	0		

③ Polarizer accidented spot

Zone Size (mm)	Acceptable Qty		
	A	B	C
$\Phi \leq 0.2$ Ignore			Ignore
$0.2 < \Phi \leq 0.5$	2(distance $\geq 10\text{mm}$)		
$\Phi > 0.5$	0		



Line defect
(LCD/TP
/Polarizer
black/white
line,
scratch,
stain)

Width(mm)	ength(mm)	Acceptable Qty		
		A	B	C
$\Phi \leq 0.03$	Ignore	Ignore		Ignore
$0.03 < W \leq 0.05$	≤ 3.0 N	≤ 2		
$0.05 < W \leq 0.08$	≤ 2.0 N	≤ 2		
$0.08 < W$	Define as spot defect			

Polarizer
Bubble

Z one Size (mm)	Acceptable Qty		
	A	B	C
$\Phi \leq 0.2$	Ignore		Ignore
$0.2 < \Phi \leq 0.4$	2 (distance ≥ 10 mm)		
$0.4 < \Phi \leq 0.6$	1		
$0.6 < \Phi$	0		

SMT

According to IPC-A-610C class II standard . Function defect and missing part are major defect ,the others are minor defect.

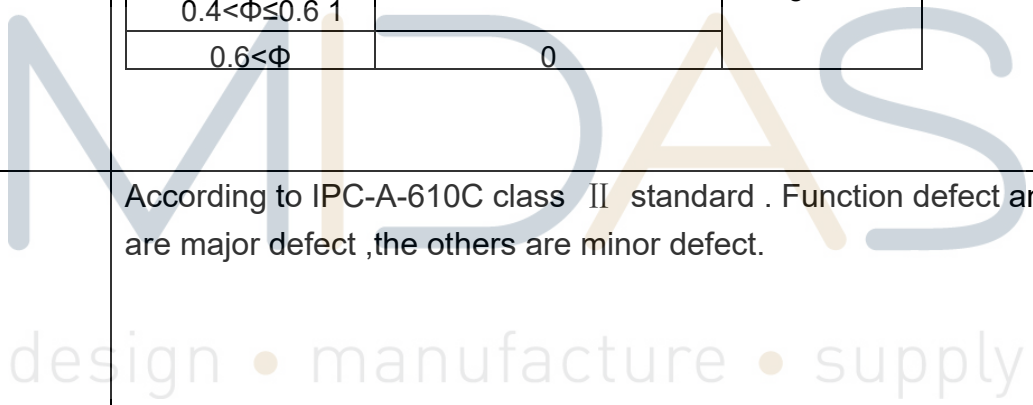

TP bubble/
accidented
spot

Size Φ (mm)	Acceptable Qty		
	A	B	C
$\Phi \leq 0.1$	Ignore		Ignore
$0.1 < \Phi \leq 0.2$	2 (distance ≥ 10 mm)		
$0.2 < \Phi \leq 0.3$	1		
$0.3 < \Phi$	0		

Assembly
deflection

beyond the edge of backlight ≤ 0.15 mm



5.0

TP
Related

Newton
Ring

Newton Ring area > 1/3
TP area NG
Newton Ring area ≤ 1/3
TP area OK



TP corner
broken
X: length
Y: width
Z: height

X	Y
$X \leq 3.0\text{mm}$	$Y \leq 3.0\text{mm}$

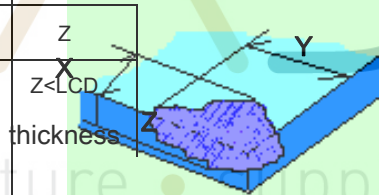

* Circuitry broken is not allowed.

TP edge
broken
X: length
Y: width
Z: height

X	Y
$X \leq 6.0\text{mm}$	$Y \leq 2.0\text{mm}$

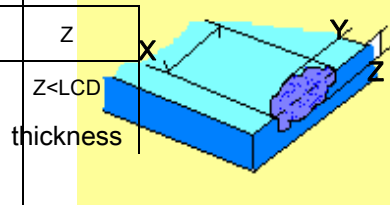

* Circuitry broken is not allowed.



Criteria (functional items)

Number	Items	Criteria (mm)
1	No display	Not allowed
2	Missing segment	Not allowed
3	Short	Not allowed
4	Backlight no lighting	Not allowed
5	TP no function	Not allowed

MIDAS

design • manufacture • supply



8. Reliability Test Result

8.1 Condition

Item	Condition	Sample Size	Test Result	Note
Low Temperature Operating Life test	-20°C, 96HR	3ea	pass	-
Thermal Humidity Operating Life test	70°C90%RH, 96HR	3ea	pass	-
Temperature Cycle ON/OFF test	-20°C ↔ 70°C, ON/OFF, 20CYC	3ea	pass	(1)
High Temperature	80°C, 96HR	3ea	pass	-



design • manufacture • supply



Storage test				
Low Temperature Storage test	- 30°C, 96HR	3ea	pass	-
ESD test	150pF, 330Ω , ±6KV(Contact)/± 8KV(Air), 5 points/panel, 10 times/point	3ea	pass	
Thermal Shock Resistance	The sample should be allowed to stand the following 5 cycles of operation: TSTL for 30 minutes -> normal temperature for 5 minutes -> TSTH for 30 minutes -> normal temperature for 5 minutes, as one cycle, then taking it out and drying it at normal temperature, and allowing it stand for 24 hours	3ea	pass	
Box Drop Test	1 Corner 3 Edges 6 faces, 66cm(MEDIUM BOX)	1box	pass	-

Note (1) ON Time over 10 seconds, OFF Time under 10 seconds

9. Cautions and Handling Precautions

9.1 Handling and Operating the Module

- (1) When the module is assembled, it should be attached to the system firmly.
Do not warp or twist the module during assembly work.
- (2) Protect the module from physical shock or any force. In addition to damage, this may cause improper operation or damage to the module and back-light unit.
- (3) Note that polarizer is very fragile and could be easily damaged. Do not press or scratch the surface.
- (4) Do not allow drops of water or chemicals to remain on the display surface.
If you have the droplets for a long time, staining and discoloration may occur.
- (5) If the surface of the polarizer is dirty, clean it using some absorbent cotton or soft cloth.
- (6) The desirable cleaners are water, IPA (Isopropyl Alcohol) or Hexane.
Do not use ketene type materials (ex. Acetone), Ethyl alcohol, Toluene, Ethyl acid or Methyl chloride. It might permanent damage to the polarizer due to chemical reaction.
- (7) If the liquid crystal material leaks from the panel, it should be kept away from the eyes or mouth. In case of contact with

hands, legs, or clothes, it must be washed away thoroughly with soap.

- (8) Protect the module from static; it may cause damage to the CMOS ICs.
- (9) Use finger-stalls with soft gloves in order to keep display clean during the incoming inspection and assembly process.
- (10) Do not disassemble the module.
- (11) Protection film for polarizer on the module shall be slowly peeled off just before use so that the electrostatic charge can be minimized.
- (12) Pins of I/F connector shall not be touched directly with bare hands.
- (13) Do not connect, disconnect the module in the "Power ON" condition.
- (14) Power supply should always be turned on/off by the item 6.1 Power On Sequence & 6.2 Power Off Sequence

9.2 Storage and Transportation.

- (1) Do not leave the panel in high temperature, and high humidity for a long time.

It is highly recommended to store the module with temperature from 0 to 35 °C and relative humidity of less than 70%

- (2) Do not store the TFT-LCD module in direct sunlight.
- (3) The module shall be stored in a dark place. When storing the modules for a long time, be sure to adopt effective measures for protecting the modules from strong ultraviolet radiation, sunlight, or fluorescent light.
- (4) It is recommended that the modules should be stored under a condition where no condensation is allowed. Formation of dewdrops may cause an abnormal operation or a failure of the module.
In particular, the greatest possible care should be taken to prevent any module from being operated where condensation has occurred inside.
- (5) This panel has its circuitry FPC on the bottom side and should be handled carefully in order not to be stressed.

design • manufacture • supply



X-ON Electronics

Largest Supplier of Electrical and Electronic Components

Click to view similar products for [midas](#) manufacturer:

Other Similar products are found below :

[MCT070LA12W1024600LML](#) [MCOT128064BY-WM](#) [MCOB21609AV-EWP](#) [MC42004A6W-SPTLY](#) [MC22008B6W-SPR](#)

[MCT035G12W320240LML](#) [MC11605A6WR-SPTLY-V2](#) [MC21605H6W-BNMLW-V2](#) [MCOT048064A1V-YI](#)

[MCT101E0CW1280800LMLIPS](#) [MCT104A0W1024768LML](#) [MCT070Z0W800480LML](#) [MCT0144C6W128128PML](#) [MCIB-16-LVDS-](#)

[CABLE](#) [MC41605A6W-FPTLA-V2](#) [MCOT128064UA1V-WM](#) [MCT101E0TW1280800LMLIPS](#) [MCT150B0W1024768LML](#)

[MCT050HDMI-A-RTP](#) [MCT050HDMI-A-CTP](#) [MCT070Z0TW1W800480LML](#) [MCT050ACA0CW800480LML](#) [MC42008A6W-SPTLY](#)

[MC42005A12W-VNMLY](#) [MC42005A12W-VNMLG](#) [MCT052A6W480128LML](#) [MC21605A6WK-BNMLW-V2](#) [MCOT256064A1A-BM](#)

[MCOT22005A1V-EYM](#) [MC20805A12W-VNMLG](#) [MC21605B6WD-BNMLW-V2](#) [MC22405A6WK-BNMLW-V2](#) [MC41605A6WK-](#)

[FPTLW-V2](#) [MCT101HDMI-A-RTP](#) [MCT024L6W240320PML](#) [MCCOG21605D6W-FPTLWI](#) [MC21605A6WD-SPTLY-V2](#)

[MC22005A6WK-BNMLW-V2](#) [MC24005AA6W9-BNMLW-V2](#) [MC42004A6WK-SPTLY-V2](#) [MC11609A6W-SPTLY-V2](#)

[MCOT064048A1V-YM](#) [MCOT128064BY-BM](#) [MCCOG128064B12W-FPTLRGB](#) [MC11609A6W-SPR-V2](#) [MC21605H6WK-BNMLW-V2](#)

[MCOT128064E1V-BM](#) [MCT070HDMI-B-RTP](#) [MDT5000C](#) [MCCOG42005A6W-BNMLWI](#)