

Features

- 65 channel engine for high performance acquisition
- GPS L1 C/A Code
- Perform 8 million time-frequency hypothesis testing per second
- Open sky hot start 2 sec
- Open sky cold start 33 sec
- Signal detection better than -160dBm
- Acquisition sensitivity -145dBm
- Accuracy 5m CEP
- Tracking current $< 50\text{mA}$
- Support active antenna
- Small size 25.4 x 25.4 x 3.2 mm (LxWxH)

GPS04**Low Cost Very High Performance SMD GPS Module**

The GPS04 is a small form factor GPS module solution intended for a broad range of Original Equipment Manufacturer (OEM) products, where fast and easy system integration and minimal development risk is required.

The GPS04 GPS receiver's -160dBm tracking sensitivity allows continuous position coverage in nearly all application environments. Its high performance search engine is capable of testing 8,000,000 time-frequency hypotheses per second, offering industry-leading signal acquisition and TTFF speed.

The receiver is optimized for applications requiring high performance, low power, and low cost; suitable for a wide range of OEM configurations including mobile phone, PND, asset tracking, and vehicle navigation products.

The very small 25.4mm x 25.4mm form factor and the SMT pads allow standard surface mount device pick-and-place process in fully automated assembly process; enabling high-volume, very cost-efficient production.

TECHNICAL SPECIFICATIONS

Receiver Type	65 parallel channel, L1 C/A code
Accuracy	Position 5m CEP Velocity 0.1m/sec 1PPS Timing +/-1us
Startup Time	2 second hot start under open sky 33 second cold start under open sky (average)
Reacquisition	2s
Sensitivity	-145dBm acquisition -160dBm tracking
Update Rate	1Hz
Dynamics	4G (39.2m/sec ²)
Operational Limits	Altitude < 18,000m or velocity < 515m/s (COCOM limit, either may be exceeded but not both)
Serial Interface	3.3V LVTTTL level
Protocol	NMEA-0183 V3.01 GPGGA, GPGLL, GPGSA, GPGSV, GPRMC, GPVTG ² Default 9600 baud rate, 8, N, 1
Datum	Default WGS-84 User definable
Input Voltage	3.3V DC +/-5%
Input Current	~70mA acquisition ~50mA tracking
Dimension	25.4mm L x 25.4mm W x 3.2mm H
Weight:	5g
Operating Temperature	-40°C ~ +85°C
Storage Temperature	-55 ~ +100°C
Humidity	5% ~ 95%

BLOCK DIAGRAM

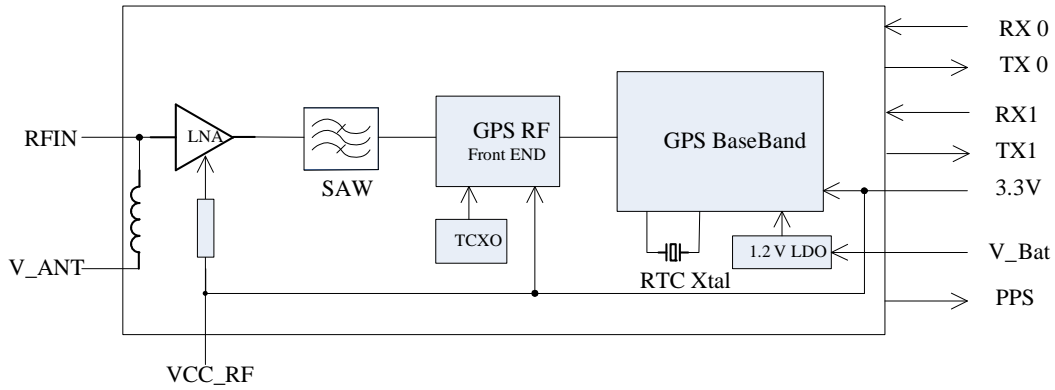

Module block schematic

ANTENNA

The GPS04 module is designed to work active antenna. Recommended active antenna should have gain of 20 ~ 30dB and noise figure less than 1.2dB.

PIN Assignment

16	GND	XN934D	GND	15
17	ANT_IN		GND	14
18	GND		GND	13
19	V_ANT		GND	12
20	VCC_RF		GND	11
21	V_BAT		GND	10
22	RESET		NC	9
23	NC		NC	8
24	NC		RX1	7
25	NC		TX1	6
26	NC		TX0	5
27	NC		RX0	4
28	NC		NC	3
29	PPS		GND	2
30	GND		VCC	1

PIN Description

Pin No.	Pin name	I/O	Description	Remark
1	Vcc	I	Module Power Supply	
2	GND	G	Ground	
3	NC	I	No Connection	
4	RX0	I	UART Serial Data Input 0	Pull up if not used
5	TX0	O	UART Serial Data Output 0	Leave Open in not used
6	TX1		UART Serial Data Output 1	Leave Open in not used
7	RX1		UART Serial Data Input 1	Pull up if not used
8	NC		No Connection	
9	NC		No Connection	
10	GND	G	Ground	
11	GND	G	Ground	
12	GND	G	Ground	
13	GND	G	Ground	
14	GND	G	Ground	
15	GND	G	Ground	
16	GND	G	Ground	
17	ANT_IN	I	Antenna Input	
18	GND	G	Ground	
19	V_ANT	I	Active Antenna External Voltage Supply	
20	Vcc_RF	O	Voltage Output for Active Antenna	
21	V_BAT	I	RTC Battery Input	Leave Open in not used
22	Reset	I	Module Reset	Leave Open in not used
23~28	NC		No Connection	Leave Open in not used
29	PPS	O	Time Pulse (1PPS)	Leave Open in not used
30	GND	G		

RECOMMENDED PCB FOOTPRINT

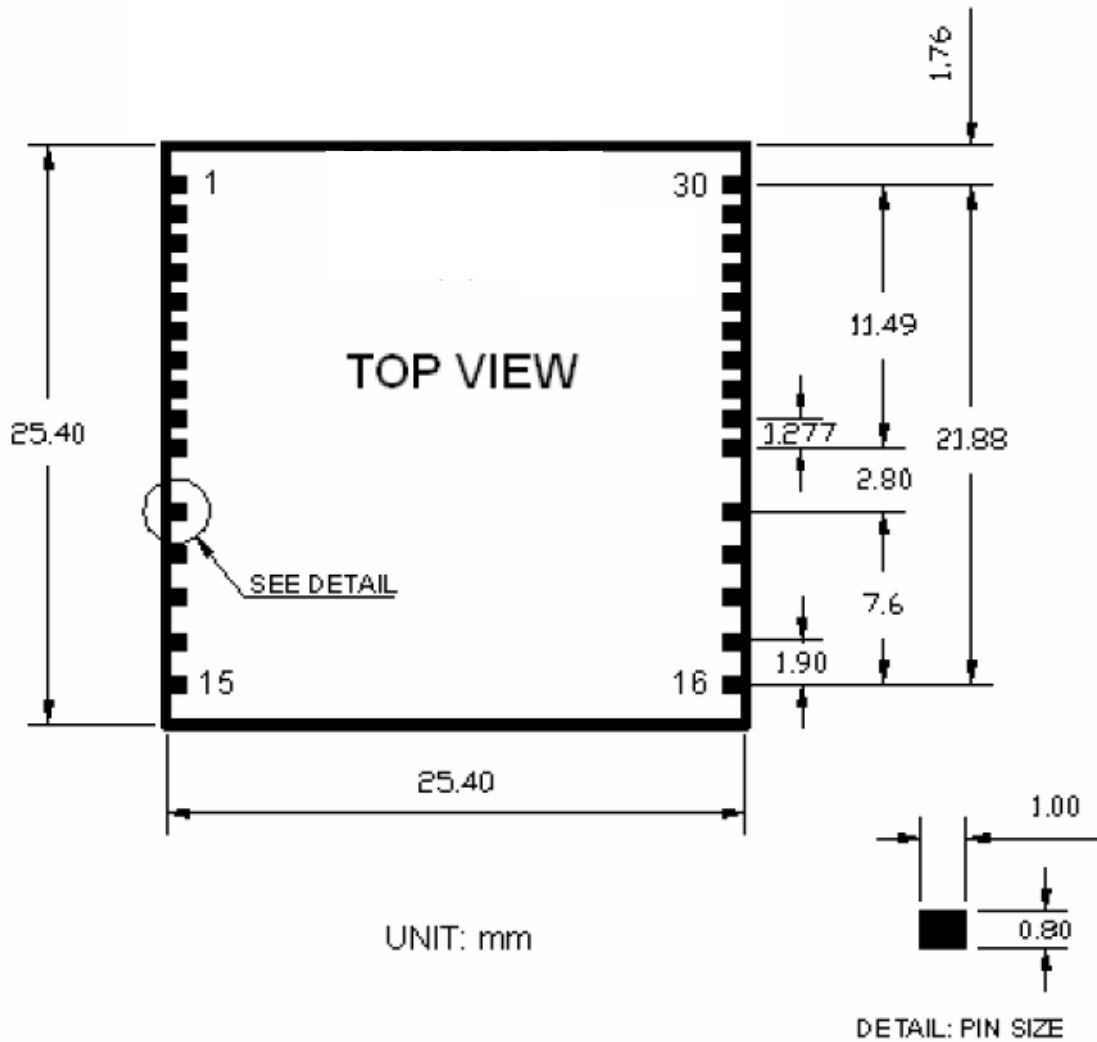

NMEA Messages

The serial interface protocol is based on the National Marine Electronics Association's NMEA 0183 ASCII interface specification. This standard is fully define in "NMEA 0183, Version 3.01" The standard may be obtained from NMEA, www.nmea.org

GGA - Global Positioning System Fix Data

Time, position and fix related data for a GPS receiver.

Structure:

```
$GPGGA,hhmmss.sss,ddmm.mmmm,a,dddmm.mmmm,a,x,xx,x.x,x.x,M,,,,,xxxx*hh<CR><LF>
```

1
2
3
4
5 6 7 8 9
10 11

Example:

```
$GPGGA,111636.932,2447.0949,N,12100.5223,E,1,11,0.8,118.2,M,,,,,0000*02<CR><LF>
```

Field	Name	Example	Description
1	UTC Time	111636.932	UTC of position in hhmmss.sss format, (000000.000 ~ 235959.999)
2	Latitude	2447.0949	Latitude in ddmm.mmmm format Leading zeros transmitted
3	N/S Indicator	N	Latitude hemisphere indicator, 'N' = North, 'S' = South
4	Longitude	12100.5223	Longitude in dddmm.mmmm format Leading zeros transmitted
5	E/W Indicator	E	Longitude hemisphere indicator, 'E' = East, 'W' = West
6	GPS quality indicator	1	GPS quality indicator 0: position fix unavailable 1: valid position fix, SPS mode 2: valid position fix, differential GPS mode 3: GPS PPS Mode, fix valid 4: Real Time Kinematic. System used in RTK mode with fixed integers 5: Float RTK. Satellite system used in RTK mode. Floating integers 6: Estimated (dead reckoning) Mode 7: Manual Input Mode 8: Simulator Mode
7	Satellites Used	11	Number of satellites in use, (00 ~ 12)
8	HDOP	0.8	Horizontal dilution of precision, (00.0 ~ 99.9)
9	Altitude	108.2	mean sea level (geoid), (-9999.9 ~ 17999.9)
10	DGPS Station ID	0000	Differential reference station ID, 0000 ~ 1023 NULL when DGPS not used
11	Checksum	02	

Note: The checksum field starts with a '*' and consists of 2 characters representing a hex number. The checksum is the exclusive OR of all characters between '\$' and '*'.

GLL – Latitude/Longitude

Latitude and longitude of current position, time, and status.

Structure:

```
$GPGLL,ddmm.mmmm,a,dddmm.mmmm,a,hhmmss.sss,A,a*hh<CR><LF>
```

1 2 3 4 5 6 7 8

Example:

```
$GPGLL,2447.0944,N,12100.5213,E,112609.932,A,A*57<CR><LF>
```

Field	Name	Example	Description
1	Latitude	2447.0944	Latitude in ddmm.mmmm format Leading zeros transmitted
2	N/S Indicator	N	Latitude hemisphere indicator 'N' = North 'S' = South
3	Longitude	12100.5213	Longitude in dddmm.mmmm format Leading zeros transmitted
4	E/W Indicator	E	Longitude hemisphere indicator 'E' = East 'W' = West
5	UTC Time	112609.932	UTC time in hhmmss.sss format (000000.000 ~ 235959.999)
6	Status	A	Status, 'A' = Data valid, 'V' = Data not valid
7	Mode Indicator	A	Mode indicator 'N' = Data not valid 'A' = Autonomous mode 'D' = Differential mode 'E' = Estimated (dead reckoning) mode 'M' = Manual input mode 'S' = Simulator mode
8	Checksum	57	

GSA – GNSS DOP and Active Satellites

GPS receiver operating mode, satellites used in the navigation solution reported by the GGA or GNS sentence and DOP values.

Structure:

```
$GPGSA,A,x,xx,xx,xx,xx,xx,xx,xx,xx,xx,xx,xx,x.x,x.x,x.x*hh<CR><LF>
  1 2 3 3 3 3 3 3 3 3 3 3 3 3 4 5 6 7
```

Example:

```
$GPGSA,A,3,05,12,21,22,30,09,18,06,14,01,31,,1.2,0.8,0.9*36<CR><LF>
```

Field	Name	Example	Description
1	Mode	A	Mode 'M' = Manual, forced to operate in 2D or 3D mode 'A' = Automatic, allowed to automatically switch 2D/3D
2	Mode	3	Fix type 1 = Fix not available 2 = 2D 3 = 3D
3	Satellite used 1~12	05,12,21,22,30 ,09,18,06,14,0 1,31,,	Satellite ID number, 01 to 32, of satellite used in solution, up to 12 transmitted
4	PDOP	1.2	Position dilution of precision (00.0 to 99.9)
5	HDOP	0.8	Horizontal dilution of precision (00.0 to 99.9)
6	VDOP	0.9	Vertical dilution of precision (00.0 to 99.9)
7	Checksum	36	

GSV – GNSS Satellites in View

Number of satellites (SV) in view, satellite ID numbers, elevation, azimuth, and SNR value. Four satellites maximum per transmission.

Structure:

```
$GPGSV,x,x,xx,xx,xx,xxx,xx,...,xx,xx,xxx,xx *hh<CR><LF>
  1 2 3 4 5 6 7 4 5 6 7 8
```

Example:

```
$GPGSV,3,1,12,05,54,069,45,12,44,061,44,21,07,184,46,22,78,289,47*72<CR><LF>
$GPGSV,3,2,12,30,65,118,45,09,12,047,37,18,62,157,47,06,08,144,45*7C<CR><LF>
$GPGSV,3,3,12,14,39,330,42,01,06,299,38,31,30,256,44,32,36,320,47*7B<CR><LF>
```

Field	Name	Example	Description
1	Number of message	3	Total number of GSV messages to be transmitted (1-3)
2	Sequence number	1	Sequence number of current GSV message
3	Satellites in view	12	Total number of satellites in view (00 ~ 12)
4	Satellite ID	05	Satellite ID number, GPS: 01 ~ 32, SBAS: 33 ~ 64 (33 = PRN120)
5	Elevation	54	Satellite elevation in degrees, (00 ~ 90)
6	Azimuth	069	Satellite azimuth angle in degrees, (000 ~ 359)
7	SNR	45	C/No in dB (00 ~ 99) Null when not tracking
8	Checksum	72	

RMC – Recommended Minimum Specific GNSS Data

Time, date, position, course and speed data provided by a GNSS navigation receiver.

Structure:

```
$GPRMC,111636.932,A,2447.0949,N,12100.5223,E,000.0,000.0,030407,,A*61<CR><LF>
```

1 2 3 4 5 6 7 8 9 10 11

Example:

```
$GPRMC,111636.932,A,2447.0949,N,12100.5223,E,000.0,000.0,030407,,A*61<CR><LF>
```

Field	Name	Example	Description
1	UTC time	0111636.932	UTC time in hhmmss.sss format (000000.00 ~ 235959.999)
2	Status	A	Status 'V' = Navigation receiver warning 'A' = Data Valid
3	Latitude	2447.0949	Latitude in dddmm.mmmm format Leading zeros transmitted
4	N/S indicator	N	Latitude hemisphere indicator 'N' = North 'S' = South
5	Longitude	12100.5223	Longitude in dddmm.mmmm format Leading zeros transmitted
6	E/W Indicator	E	Longitude hemisphere indicator 'E' = East 'W' = West
7	Speed over ground	000.0	Speed over ground in knots (000.0 ~ 999.9)
8	Course over ground	000.0	Course over ground in degrees (000.0 ~ 359.9)
9	UTC Date	030407	UTC date of position fix, ddmmyy format
10	Mode indicator	A	Mode indicator 'N' = Data not valid 'A' = Autonomous mode 'D' = Differential mode 'E' = Estimated (dead reckoning) mode 'M' = Manual input mode 'S' = Simulator mode
11	checksum	61	

VTG – Course Over Ground and Ground Speed

The actual course and speed relative to the ground.

Structure:

GPVTG,x.x,T,,M,x.x,N,x.x,K,a*hh<CR><LF>
1 2 3 4 5

Example:

\$GPVTG, 000.0,T,,M,000.0,N,0000.0,K,A*3D<CR><LF>

Field	Name	Example	Description
1	Course	000.0	True course over ground in degrees (000.0 ~ 359.9)
2	Speed	000.0	Speed over ground in knots (000.0 ~ 999.9)
3	Speed	0000.0	Speed over ground in kilometers per hour (0000.0 ~ 1800.0)
4	Mode	A	Mode indicator 'N' = not valid 'A' = Autonomous mode 'D' = Differential mode 'E' = Estimated (dead reckoning) mode 'M' = Manual input mode 'S' = Simulator mode
5	Checksum	3D	

ORDERING INFORMATION

Model Name	Description
GPS04	Default 9600 baud rate

X-ON Electronics

Largest Supplier of Electrical and Electronic Components

Click to view similar products for [GPS Modules](#) category:

Click to view products by [Hope Microelectronics](#) manufacturer:

Other Similar products are found below :

[A5135-H](#) [EWM-G109H01E](#) [ISM3333-C6.1](#) [S2-106ZN](#) [S2-105V4-Z185K](#) [MIKROE-4150](#) [GPS-11858](#) [4037735104327](#) [RXM-GNSS-TM-T](#)
[EWM-G108H01E](#) [DD-14239](#) [GPS-10922](#) [GPS-12751](#) [NEO-M8P-2](#) [SIM28ML](#) [RXM-GNSS-GM-T](#) [SIM28](#) [M10578-A3](#) [M10578-A3-U2](#)
[TEL0132](#) [POL-2G](#) [POL-3G](#) [FT-X-GPS](#) [GPS-13740](#) [PKG300060P](#) [PKG300071](#) [PKG300071P](#) [PKG900000000271T](#) [PKG900000000853P](#)
[PKG900000000853T](#) [EZ-GPS-G](#) [A2235H](#) [RXM-GNSS-TM-B](#) [RXM-GPS-F4-T](#) [RXM-GPS-FM-B](#) [RXM-GPS-FM-T](#) [RXM-GPS-R4-T](#)
[A1084-A](#) [A2100-A](#) [A2200-A](#) [A2235-H](#) [A5100-A](#) [28504](#) [L26ADR-S89](#) [L26T-S89](#) [L89-S90](#) [101990655](#) [113990659](#) [GPS-13670](#) [TESEO-](#)
[LIV3F](#)