

# 74F112

## Dual JK Negative Edge-Triggered Flip-Flop

### General Description

The 74F112 contains two independent, high-speed JK flip-flops with Direct Set and Clear inputs. Synchronous state changes are initiated by the falling edge of the clock. Triggering occurs at a voltage level of the clock and is not directly related to the transition time. The J and K inputs can change when the clock is in either state without affecting the flip-flop, provided that they are in the desired state during the recommended setup and hold times relative to the falling edge of the clock. A LOW signal on  $\bar{S}_D$  or  $\bar{C}_D$  prevents clocking and forces Q or  $\bar{Q}$  HIGH, respectively.

Simultaneous LOW signals on  $\bar{S}_D$  and  $\bar{C}_D$  force both Q and  $\bar{Q}$  HIGH.

#### Asynchronous Inputs:

- LOW input to  $\bar{S}_D$  sets Q to HIGH level
- LOW input to  $\bar{C}_D$  sets Q to LOW level
- Clear and Set are independent of clock
- Simultaneous LOW on  $\bar{C}_D$  and  $\bar{S}_D$  makes both Q and  $\bar{Q}$  HIGH

### Ordering Code:

Order Number	Package Number	Package Description
74F112SC	M16A	16-Lead Small Outline Integrated Circuit (SOIC), JEDEC MS-012, 0.150 Narrow
74F112SJ	M16D	16-Lead Small Outline Package (SOP), EIAJ TYPE II, 5.3mm Wide
74F112PC	N16E	16-Lead Plastic Dual-In-Line Package (PDIP), JEDEC MS-001, 0.300 Wide

Devices also available in Tape and Reel. Specify by appending the suffix letter "X" to the ordering code.

### Logic Symbols

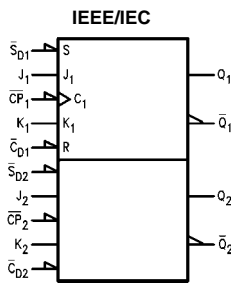
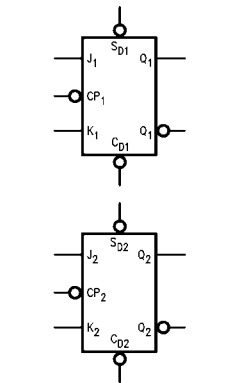

### Connection Diagram

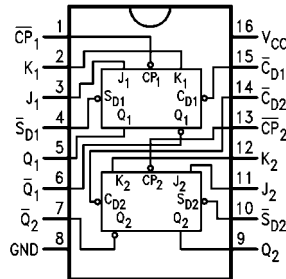

### Unit Loading/Fan Out

Pin Names	Description	U.L. HIGH/LOW	Input $I_{IH}/I_{IL}$ Output $I_{OH}/I_{OL}$
$J_1, J_2, K_1, K_2$	Data Inputs	1.0/1.0	20 $\mu$ A/-0.6 mA
$\overline{CP}_1, \overline{CP}_2$	Clock Pulse Inputs (Active Falling Edge)	1.0/4.0	20 $\mu$ A/-2.4 mA
$\overline{CD}_1, \overline{CD}_2$	Direct Clear Inputs (Active LOW)	1.0/5.0	20 $\mu$ A/-3.0 mA
$\overline{SD}_1, \overline{SD}_2$	Direct Set Inputs (Active LOW)	1.0/5.0	20 $\mu$ A/-3.0 mA
$Q_1, Q_2, \overline{Q}_1, \overline{Q}_2$	Outputs	50/33.3	-1 mA/20 mA

### Truth Table

Inputs					Outputs	
$\overline{SD}$	$\overline{CD}$	$\overline{CP}$	J	K	Q	$\overline{Q}$
L	H	X	X	X	H	L
H	L	X	X	X	L	H
L	L	X	X	X	H	H
H	H	$\sim$	h	h	$\overline{Q}_0$	$Q_0$
H	H	$\sim$	l	h	L	H
H	H	$\sim$	h	l	H	L
H	H	$\sim$	l	l	$Q_0$	$\overline{Q}_0$

H (h) = HIGH Voltage Level  
 L (l) = LOW Voltage Level  
 X = Immaterial

$\sim$  = HIGH-to-LOW Clock Transition

$Q_0(\overline{Q}_0)$  = Before HIGH-to-LOW Transition of Clock

Lower case letters indicate the state of the referenced input or output one setup time prior to the HIGH-to-LOW clock transition.

### Logic Diagram

(One Half Shown)

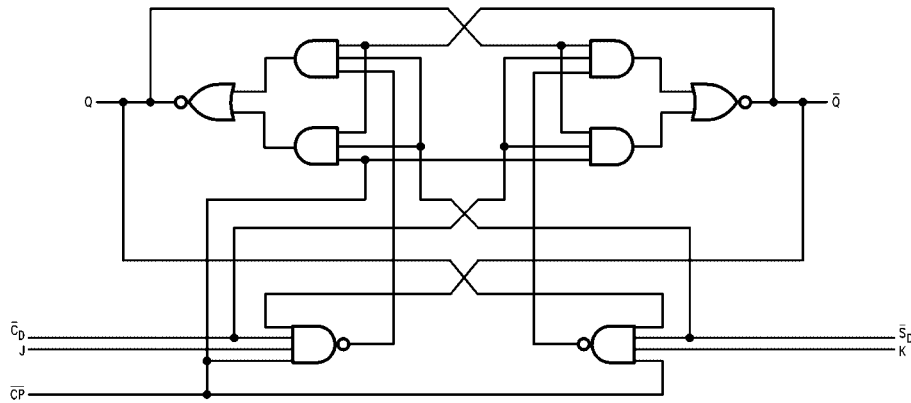

Please note that this diagram is provided only for the understanding of logic operations and should not be used to estimate propagation delays.

**Absolute Maximum Ratings**(Note 1)

Storage Temperature	-65°C to +150°C
Ambient Temperature under Bias	-55°C to +125°C
Junction Temperature under Bias	-55°C to +150°C
V <sub>CC</sub> Pin Potential to Ground Pin	-0.5V to +7.0V
Input Voltage (Note 2)	-0.5V to +7.0V
Input Current (Note 2)	-30 mA to +5.0 mA
Voltage Applied to Output in HIGH State (with V <sub>CC</sub> = 0V)	
Standard Output	-0.5V to V <sub>CC</sub>
3-STATE Output	-0.5V to +5.5V
Current Applied to Output in LOW State (Max)	twice the rated I <sub>OL</sub> (mA)

**Recommended Operating Conditions**

Free Air Ambient Temperature	0°C to +70°C
Supply Voltage	+4.5V to +5.5V

**Note 1:** Absolute maximum ratings are values beyond which the device may be damaged or have its useful life impaired. Functional operation under these conditions is not implied.

**Note 2:** Either voltage limit or current limit is sufficient to protect inputs.

**DC Electrical Characteristics**

Symbol	Parameter	Min	Typ	Max	Units	V <sub>CC</sub>	Conditions
V <sub>IH</sub>	Input HIGH Voltage	2.0			V		Recognized as a HIGH Signal
V <sub>IL</sub>	Input LOW Voltage			0.8	V		Recognized as a LOW Signal
V <sub>CD</sub>	Input Clamp Diode Voltage			-1.2	V	Min	I <sub>IN</sub> = -18 mA
V <sub>OH</sub>	Output HIGH Voltage	10% V <sub>CC</sub> 5% V <sub>CC</sub>	2.5 2.7		V	Min	I <sub>OH</sub> = -1 mA I <sub>OH</sub> = -1 mA
V <sub>OL</sub>	Output LOW Voltage	10% V <sub>CC</sub>		0.5	V	Min	I <sub>OL</sub> = 20 mA
I <sub>IH</sub>	Input HIGH Current			5.0	μA	Max	V <sub>IN</sub> = 2.7V
I <sub>BVI</sub>	Input HIGH Current Breakdown Test			7.0	μA	Max	V <sub>IN</sub> = 7.0V
I <sub>CEX</sub>	Output HIGH Leakage Current			50	μA	Max	V <sub>OUT</sub> = V <sub>CC</sub>
V <sub>ID</sub>	Input Leakage Test	4.75			V	0.0	I <sub>ID</sub> = 1.9 μA All other pins grounded
I <sub>OD</sub>	Output Leakage Circuit Current			3.75	μA	0.0	V <sub>IOD</sub> = 150 mV All other pins grounded
I <sub>IL</sub>	Input LOW Current			-0.6 -2.4 -3.0	mA	Max	V <sub>IN</sub> = 0.5V (J <sub>n</sub> , K <sub>n</sub> ) V <sub>IN</sub> = 0.5V (CP <sub>n</sub> ) V <sub>IN</sub> = 0.5V (CD <sub>n</sub> , SD <sub>n</sub> )
I <sub>OS</sub>	Output Short-Circuit Current	-60		-150	mA	Max	V <sub>OUT</sub> = 0V
I <sub>CCH</sub>	Power Supply Current		12	19	mA	Max	V <sub>O</sub> = HIGH
I <sub>CCL</sub>	Power Supply Current		12	19	mA	Max	V <sub>O</sub> = LOW

### AC Electrical Characteristics

Symbol	Parameter	T <sub>A</sub> = +25°C V <sub>CC</sub> = +5.0V C <sub>L</sub> = 50 pF			T <sub>A</sub> = 0°C to +70°C V <sub>CC</sub> = +5.0V C <sub>L</sub> = 50 pF		Units
		Min	Typ	Max	Min	Max	
f <sub>MAX</sub>	Maximum Clock Frequency	85	105		80		MHz
t <sub>PLH</sub>	Propagation Delay	2.0	5.0	6.5	2.0	7.5	ns
t <sub>PHL</sub>	$\overline{CP}_n$ to Q <sub>n</sub> or $\overline{Q}_n$	2.0	5.0	6.5	2.0	7.5	
t <sub>PLH</sub>	Propagation Delay	2.0	4.5	6.5	2.0	7.5	ns
t <sub>PHL</sub>	$\overline{C}_{Dn}$ , $\overline{S}_{Dn}$ to $\overline{Q}_n$ , $\overline{Q}_n$	2.0	4.5	6.5	2.0	7.5	

### AC Operating Requirements

Symbol	Parameter	T <sub>A</sub> = +25°C V <sub>CC</sub> = +5.0V		T <sub>A</sub> = 0°C to +70°C V <sub>CC</sub> = +5.0V		Units
		Min	Max	Min	Max	
t <sub>S(H)</sub>	Setup Time, HIGH or LOW	4.0		5.0		ns
t <sub>S(L)</sub>	J <sub>n</sub> or K <sub>n</sub> to $\overline{CP}_n$	3.0		3.5		
t <sub>H(H)</sub>	Hold Time, HIGH or LOW	0		0		
t <sub>H(L)</sub>	J <sub>n</sub> or K <sub>n</sub> to $\overline{CP}_n$	0		0		
t <sub>W(H)</sub>	$\overline{CP}$ Pulse Width	4.5		5.0		ns
t <sub>W(L)</sub>	HIGH or LOW	4.5		5.0		
t <sub>W(L)</sub>	Pulse Width, LOW	4.5		5.0		ns
t <sub>W(L)</sub>	$\overline{C}_{Dn}$ or $\overline{S}_{Dn}$	4.5		5.0		
t <sub>REC</sub>	Recovery Time	4.0		5.0		ns
t <sub>REC</sub>	$\overline{S}_{Dn}$ , $\overline{C}_{Dn}$ to $\overline{CP}$	4.0		5.0		

**Physical Dimensions** inches (millimeters) unless otherwise noted



**16-Lead Small Outline Integrated Circuit (SOIC), JEDEC MS-012, 0.150 Narrow Package Number M16A**

**Physical Dimensions** inches (millimeters) unless otherwise noted (Continued)



DIMENSIONS ARE IN MILLIMETERS

- NOTES:
- A. CONFORMS TO EIAJ EDR-7320 REGISTRATION, ESTABLISHED IN DECEMBER, 1998.
  - B. DIMENSIONS ARE IN MILLIMETERS.
  - C. DIMENSIONS ARE EXCLUSIVE OF BURRS, MOLD FLASH, AND TIE BAR EXTRUSIONS.

M16DRevB1

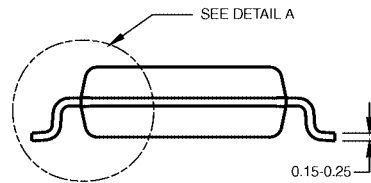

**16-Lead Small Outline Package (SOP), EIAJ TYPE II, 5.3mm Wide Package Number M16D**

**Physical Dimensions** inches (millimeters) unless otherwise noted (Continued)



**16-Lead Plastic Dual-In-Line Package (PDIP), JEDEC MS-001, 0.300 Wide Package Number N16E**

Fairchild does not assume any responsibility for use of any circuitry described, no circuit patent licenses are implied and Fairchild reserves the right at any time without notice to change said circuitry and specifications.

**LIFE SUPPORT POLICY**

FAIRCHILD'S PRODUCTS ARE NOT AUTHORIZED FOR USE AS CRITICAL COMPONENTS IN LIFE SUPPORT DEVICES OR SYSTEMS WITHOUT THE EXPRESS WRITTEN APPROVAL OF THE PRESIDENT OF FAIRCHILD SEMICONDUCTOR CORPORATION. As used herein:

1. Life support devices or systems are devices or systems which, (a) are intended for surgical implant into the body, or (b) support or sustain life, and (c) whose failure to perform when properly used in accordance with instructions for use provided in the labeling, can be reasonably expected to result in a significant injury to the user.
2. A critical component in any component of a life support device or system whose failure to perform can be reasonably expected to cause the failure of the life support device or system, or to affect its safety or effectiveness.

[www.fairchildsemi.com](http://www.fairchildsemi.com)

## X-ON Electronics

Largest Supplier of Electrical and Electronic Components

*Click to view similar products for [Flip Flops](#) category:*

*Click to view products by [ON Semiconductor](#) manufacturer:*

Other Similar products are found below :

[5962-8955201EA](#) [MC74HC11ADTG](#) [MC10EP29MNG](#) [MC74HC11ADTR2G](#) [NLV14013BDTR2G](#) [NLV14027BDG](#) [NLX1G74MUTCG](#)  
[703557B](#) [746431H](#) [5962-90606022A](#) [5962-9060602FA](#) [NLV14013BDR2G](#) [M38510/30104BDA](#) [M38510/07106BFA](#) [M38510/06102BFA](#)  
[M38510/06101B2A](#) [NLV74HC74ADR2G](#) [TC4013BP\(N,F\)](#) [NLV14013BDG](#) [NLV74AC32DR2G](#) [NLV74AC74DR2G](#) [MC74HC73ADG](#)  
[CY74FCT16374CTPACT](#) [MC74HC11ADR2G](#) [74LVT74D,118](#) [74VHCT9273FT\(BJ\)](#) [MM74HC374WM](#) [74ALVCH162374PAG](#)  
[TC7WZ74FK,LJ\(CT](#) [CD54HCT273F](#) [HMC853LC3TR](#) [HMC723LC3CTR](#) [MM74HCT574MTCX](#) [MM74HCT273WM](#) [SN74LVC74APW](#)  
[SN74LVC74AD](#) [MC74HC73ADTR2G](#) [MC74HC11ADG](#) [SN74ALVTH16374GR](#) [M74HCT273B1R](#) [M74HC377RM13TR](#)  
[M74HC374RM13TR](#) [M74HC175B1R](#) [M74HC174RM13TR](#) [74ALVTH16374ZQLR](#) [74ALVTH32374ZKER](#) [74AUP1G74DC,125](#)  
[74VHC374FT\(BJ\)](#) [74VHC9273FT\(BJ\)](#) [NLV14013BCPG](#)