



Midas Active Matrix Display Part Number System

MC T 057 A 6 * W 320240 L M L * * * * *
1 2 3 4 5 6 7 8 9 10 11 12 13 14 15 16

- 1 = **MC:** Midas Components
- 2 = **T:** TFT **A:** Active Matrix OLED
- 3 = **Size**
- 4 = **Series**
- 5 = **Viewing Angle: 6:** 6 O'clock **12:** 12 O'clock
- 6 = **Blank:** No Touch **T:** Resistive Touchscreen **C:** Capacitive Touchscreen
- 7 = **Operating Temp Range: S:** 0 to 50Deg C **B:** -20+60Deg C
W: -20+70Deg C **E:** -30+85Deg C
- 8 = **No of Pixels**
- 9 = **Orientation: P:** Portrait **L:** Landscape
- 10 = **Mode: R:** Reflective **M:** Transmissive **T:** Transflective
S: Sunlight Readable (transmissive)
- 11 = **Backlight: Blank:** None **L:** LED **C:** CCFL
- 12 = **Blank:** No Module/board **C:** Controller board module
- 13 = **Blank:** None **V:** Video
- 14 = **Blank:** None **B:** Bracket
- 15 = **Blank:** None **H:** Host Cable
- 16 = **Blank:** None **K:** Keyboard

CONTENTS

List	Description	Page No.
1	GENERAL SPECIFICATIONS	4
2	BLOCK DIAGRAM	5
3	DIMENSIONAL OUTLINE	6
4	PIN DESCRIPTION	7
5	ELECTRICAL CHARACTERISTICS	9
6	INPUT SIGNAL TIMING	11
7	OPTICAL CHARACTERISTICS	18
8	PACKAGE	21



1. GENERAL SPECIFICATIONS

ITEM	SPECIFICATION	UNIT
OUTLINE DIMENSIONS	47.2 (W) X60.26 (H) X2.45 (D)	mm
DISPLAY SIZE	2.4	inch
DOT PITCH	0.153mmX0.153mm	mm
NUMBER OF DOTS	240* (RGB) *320	-
DRIVER IC	ILI9341	-
LCD TYPE	TFT(262K) TRANSMISSIVE	-
INTERFACE	MCU 16 BITS	
BACKLIGHT TYPE	LED White	-
VIEWING DIRECTION	6 O'clock	-

***See attached drawing for details.**

2. BLOCK DIAGRAM

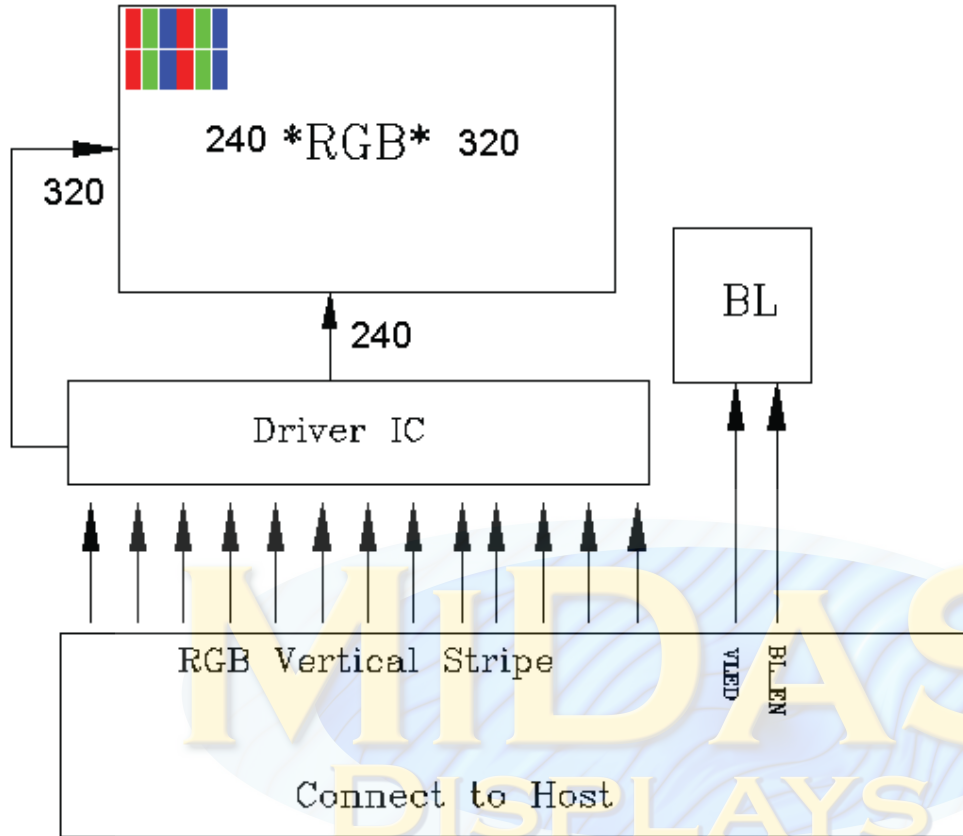

3. DIMENSIONAL OUTLINE

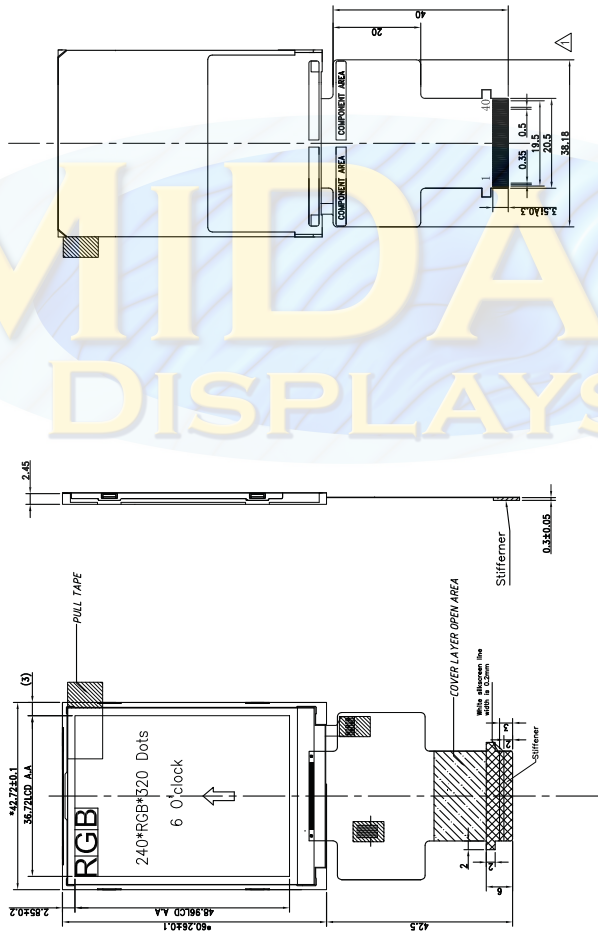

NOTES:

1. Display type: 2.4" TFT, 240(RGB)X320
2. Viewing angle: 6 O'clock
3. Display mode: 262K TFT/Transmissive/Normal White
4. Operating temp.: -20°C~+70°C
5. Storage temp.: -30°C~+80°C
6. IC: ILI6341
7. Logic power supply voltage: 2.8V
8. Backlight: 4 chip White LED, In Parallel, If=60mA
9. Luminance: 250cd/m²
10. All the raw material are Rohs compliant

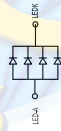

B/L CIRCUIT DIAGRAM
4 PCS WHITE LED;IF =60mA,VF=3.2V

MIDAS
DISPLAYS

4. PIN DESCRIPTION:

NO.	PIN NAME	Type	Description																																																																																													
1	LEDK	P	Power supply for LED (Cathode)																																																																																													
2	LEDA	P	Power supply for LED (Anode)																																																																																													
3	GND	P	Ground(0V)																																																																																													
4-6	NC	-	No connection																																																																																													
7	SDA	I/O	SPI Serial Data Input/output																																																																																													
8	DOTCLK	I	Pixel clock signal																																																																																													
9	DE	I	Data enable																																																																																													
10	VSYNC	I	Vertical synchronizing signal																																																																																													
11	HSYNC	I	Horizontal synchronizing signal																																																																																													
12	VCC	P	Power voltage																																																																																													
13	RESET	I	Reset signal																																																																																													
14	GND	P	Ground(0V)																																																																																													
15-32	DB17~DB0	I/O	<p>Data bus - Select the MCU interface mode</p> <table border="1"> <thead> <tr> <th rowspan="2">IM3</th> <th rowspan="2">IM2</th> <th rowspan="2">IM1</th> <th rowspan="2">IM0</th> <th rowspan="2">MCU-Interface Mode</th> <th colspan="2">DB Pin in use</th> </tr> <tr> <th>Register/Content</th> <th>GRAM</th> </tr> </thead> <tbody> <tr> <td>0</td> <td>0</td> <td>0</td> <td>0</td> <td>80 MCU 8-bit bus interface I</td> <td>D[7:0]</td> <td>D[7:0]</td> </tr> <tr> <td>0</td> <td>0</td> <td>0</td> <td>1</td> <td>80 MCU 16-bit bus interface I</td> <td>D[7:0]</td> <td>D[15:0]</td> </tr> <tr> <td>0</td> <td>0</td> <td>1</td> <td>0</td> <td>80 MCU 9-bit bus interface I</td> <td>D[7:0]</td> <td>D[8:0]</td> </tr> <tr> <td>0</td> <td>0</td> <td>1</td> <td>1</td> <td>80 MCU 18-bit bus interface I</td> <td>D[7:0]</td> <td>D[17:0]</td> </tr> <tr> <td>0</td> <td>1</td> <td>0</td> <td>1</td> <td>3-wire 9-bit data serial interface I</td> <td colspan="2">SDA: In/OUT</td> </tr> <tr> <td>0</td> <td>1</td> <td>1</td> <td>0</td> <td>4-wire 8-bit data serial interface I</td> <td colspan="2">SDA: In/OUT</td> </tr> <tr> <td>1</td> <td>0</td> <td>0</td> <td>0</td> <td>80 MCU 16-bit bus interface II</td> <td>D[8:1]</td> <td>D[17:10], D[8:1]</td> </tr> <tr> <td>1</td> <td>0</td> <td>0</td> <td>1</td> <td>80 MCU 8-bit bus interface II</td> <td>D[17:10]</td> <td>D[17:10]</td> </tr> <tr> <td>1</td> <td>0</td> <td>1</td> <td>0</td> <td>80 MCU 18-bit bus interface II</td> <td>D[8:1]</td> <td>D[17:0]</td> </tr> <tr> <td>1</td> <td>0</td> <td>1</td> <td>1</td> <td>80 MCU 9-bit bus interface II</td> <td>D[17:10]</td> <td>D[17:9]</td> </tr> <tr> <td>1</td> <td>1</td> <td>0</td> <td>1</td> <td>3-wire 9-bit data serial interface II</td> <td colspan="2">SDI: In SDO: Out</td> </tr> <tr> <td>1</td> <td>1</td> <td>1</td> <td>0</td> <td>4-wire 8-bit data serial interface II</td> <td colspan="2">SDI: In SDO: Out</td> </tr> </tbody> </table> <p>MPU Parallel interface bus and serial interface select If use RGB Interface must select serial interface. *: Fix this pin at VDDI or VSS.</p>	IM3	IM2	IM1	IM0	MCU-Interface Mode	DB Pin in use		Register/Content	GRAM	0	0	0	0	80 MCU 8-bit bus interface I	D[7:0]	D[7:0]	0	0	0	1	80 MCU 16-bit bus interface I	D[7:0]	D[15:0]	0	0	1	0	80 MCU 9-bit bus interface I	D[7:0]	D[8:0]	0	0	1	1	80 MCU 18-bit bus interface I	D[7:0]	D[17:0]	0	1	0	1	3-wire 9-bit data serial interface I	SDA: In/OUT		0	1	1	0	4-wire 8-bit data serial interface I	SDA: In/OUT		1	0	0	0	80 MCU 16-bit bus interface II	D[8:1]	D[17:10], D[8:1]	1	0	0	1	80 MCU 8-bit bus interface II	D[17:10]	D[17:10]	1	0	1	0	80 MCU 18-bit bus interface II	D[8:1]	D[17:0]	1	0	1	1	80 MCU 9-bit bus interface II	D[17:10]	D[17:9]	1	1	0	1	3-wire 9-bit data serial interface II	SDI: In SDO: Out		1	1	1	0	4-wire 8-bit data serial interface II	SDI: In SDO: Out	
IM3	IM2	IM1	IM0						MCU-Interface Mode	DB Pin in use																																																																																						
				Register/Content	GRAM																																																																																											
0	0	0	0	80 MCU 8-bit bus interface I	D[7:0]	D[7:0]																																																																																										
0	0	0	1	80 MCU 16-bit bus interface I	D[7:0]	D[15:0]																																																																																										
0	0	1	0	80 MCU 9-bit bus interface I	D[7:0]	D[8:0]																																																																																										
0	0	1	1	80 MCU 18-bit bus interface I	D[7:0]	D[17:0]																																																																																										
0	1	0	1	3-wire 9-bit data serial interface I	SDA: In/OUT																																																																																											
0	1	1	0	4-wire 8-bit data serial interface I	SDA: In/OUT																																																																																											
1	0	0	0	80 MCU 16-bit bus interface II	D[8:1]	D[17:10], D[8:1]																																																																																										
1	0	0	1	80 MCU 8-bit bus interface II	D[17:10]	D[17:10]																																																																																										
1	0	1	0	80 MCU 18-bit bus interface II	D[8:1]	D[17:0]																																																																																										
1	0	1	1	80 MCU 9-bit bus interface II	D[17:10]	D[17:9]																																																																																										
1	1	0	1	3-wire 9-bit data serial interface II	SDI: In SDO: Out																																																																																											
1	1	1	0	4-wire 8-bit data serial interface II	SDI: In SDO: Out																																																																																											
33	RD	I	Read signal, active at low in MCU mode; In RGB and SPI mode, connect to GNG																																																																																													
34	WR	I	Write Signal, active at low in MCU mode; In RGB and SPI mode ,SPI Serial Clock																																																																																													
35	RS	I	In MCU mode, Register select signal, low is selected data register; High is selected command register. In RGB and SPI mode, connect to GND																																																																																													
36	CS	I	Chip selection pin/ Serial port data enable signal																																																																																													
37	XR(NC)	-	No connection																																																																																													
38	YD(NC)	-	No connection																																																																																													
39	XL(NC)	-	No connection																																																																																													
40	YU(NC)	-	No connection																																																																																													

Note: 1: input, 0: output, P: Power;

Note: 2: LCM have set to 80 MCU 16-bit bus interface I. Below is circuit on FPC for IM3-IM0.

IM3	IM2	IM1	IM0	MCU-Interface Mode	DB pin in use		PIN
					Register/content	GRAM	
0	0	0	0	80 MCU 8bit -bus	DB(7-0)	DB(7-0)	HS,VS
0	0	0	1	80 MCU 16bit -bus	DB(7-0)	DB(15-0)	HS,VS
0	0	1	0	80 MCU 9bit -bus	DB(7-0)	DB(8-0)	HS,VS
0	0	1	1	80 MCU 18bit -bus	DB(7-0)	DB(17-0)	HS,VS
0	1	0	1	3-wire 9-bit date serial	SDA in/out		HS,VS
0	1	1	0	4-wire 8-bit date serial	SDA in/out		HS,VS
1	0	0	0	80 MCU 16bit -bus	DB(8-1)	DB(17-10) (8-1)	HS,VS
1	0	0	1	80 MCU 8bit -bus	DB(17-10)	DB(17-10)	HS,VS
1	0	1	0	80 MCU 18bit -bus	DB(17-10)	DB(17-0)	HS,VS
1	0	0	1	80 MCU 9bit -bus	DB(8-0)	DB(17-9)	HS,VS
R6=0	R5=0	R3=0	R1=0				
R8=1	R6=1	R4=1	R2=1				

NOTE:

Default interface of this part is "80 MCU 16-bit bus interface I" ([IM3:IM0] =0001), and "HS", "VS", "DB" already are connected to GND via 0 ohm resistor on FPC. Refer to below circuit.

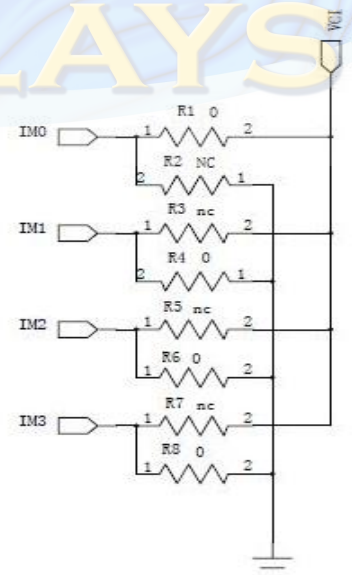

5. ELECTRICAL CHARACTERISTICS

5.1 Absolute Maximum Ratings

Item	Symbol	Values		Unit	Remark
		Min	Max		
Power Supply for Pump	VCC	-0.3	4.5	V	
Operating temperature range	To	-20	70	Degree C	
Storage temperature range	Ts	-30	80	Degree C	
Logic input voltage range	VI	-0.3	VCC+0.3	V	
Logic input voltage range	VO	-0.3	VCC+0.3	V	

Note: Stresses beyond those given in the Absolute Maximum Rating table may cause operational errors or damage to the device. For normal operational conditions see AC/DC Electrical Characteristics

5.2 DC Characteristics

5.2.2 DC Characteristics for Digital Circuit

Item	Symbol	Values			Unit	Conditions
		Min	Typ	Max		
Low Level Input Voltage	Vil	GND	-	0.3xVCC	v	
High Level Input Voltage	Vih	0.7xVCC	-	VCC	uA	
High Level Output Voltage	Voh	VCC-0.4	-	VCC	ohm	
Low Level Output Voltage	Vol	GND	-	GND+0.4	uA	
Power Supply	VCC	2.5	2.8	3.3	V	
Input Leakage Current	Iil			±1.0	uA	
Pull High/Low Resistor	Rp	-	100K	-	ohm	

5.3 DC Backlight Unit

Item	Symbol	Min.	Typ.	Max.	Unit	Remark
Average Luminous Intensity	Iv		250		cd/m ²	IF=60mA
Chromaticity Coordinates	X	0.234	0.284	0.334		IF=60mA
	Y	0.273	0.323	0.373		IF=60mA
Forward Voltage	VF		3.2	3.4	V	IF=60mA
Reverse Current	IR			50	μA	VR=5V, 1LED
Luminous Tolerance	IV-M	80			%	(MIN/MAX)×100
Power Dissipation	Pd	192			mW	
Peak Forward Current	Ifp	100			uA	
Reverse Voltage	VR	5			V	

B/L CIRCUIT DIAGRAM

4 PCS WHITE LED; IF = 60mA, VF = 3.2V

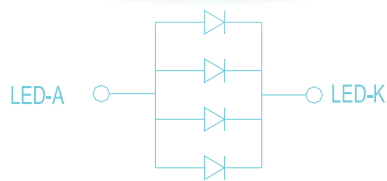

6. INPUT SIGNAL TIMING

6.1 Display Parallel 18/16/9/8-bit Interface Timing Characteristics (8080-I system)

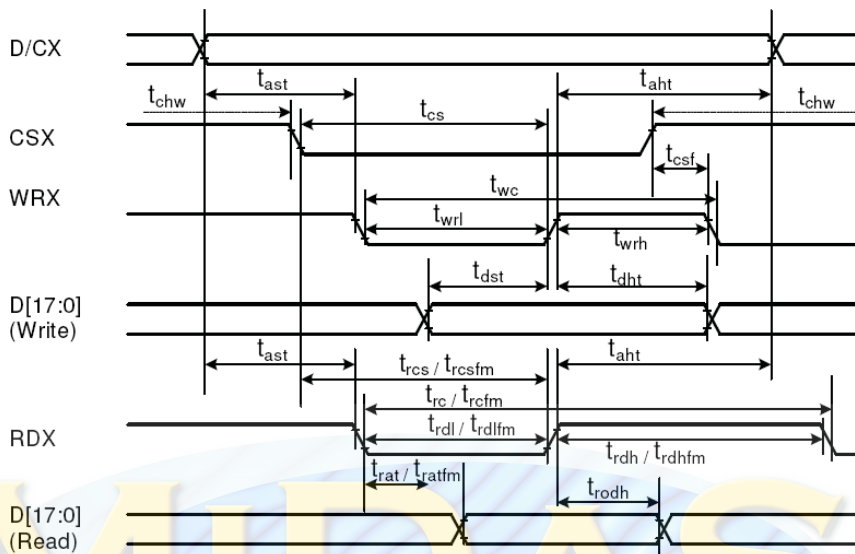

Signal	Symbol	Parameter	min	max	Unit	Description
DCX	tast	Address setup time	0	-	ns	
	taht	Address hold time (Write/Read)	0	-	ns	
CSX	tchw	CSX "H" pulse width	0	-	ns	
	tcs	Chip Select setup time (Write)	15	-	ns	
	trcs	Chip Select setup time (Read ID)	45	-	ns	
	trcsfm	Chip Select setup time (Read FM)	355	-	ns	
WRX	tcsf	Chip Select Wait time (Write/Read)	10	-	ns	
	twc	Write cycle	66	-	ns	
	twrh	Write Control pulse H duration	15	-	ns	
RDX (FM)	twrh	Write Control pulse L duration	15	-	ns	
	ttrc	Read Cycle (FM)	450	-	ns	
	ttrdhfm	Read Control H duration (FM)	90	-	ns	
RDX (ID)	ttrdlfm	Read Control L duration (FM)	355	-	ns	
	trc	Read cycle (ID)	160	-	ns	
	trdh	Read Control pulse H duration	90	-	ns	
D[17:0], D[15:0], D[8:0], D[7:0]	trdl	Read Control pulse L duration	45	-	ns	
	tdst	Write data setup time	10	-	ns	For maximum CL=30pF For minimum CL=8pF
	tdht	Write data hold time	10	-	ns	
	trat	Read access time	-	40	ns	
tratfm	Read access time	-	340	ns		
	trodh	Read output disable time	20	80	ns	

Note: $T_a = -30$ to 70 °C, $V_{DDI}=1.65V$ to $3.3V$, $V_{CI}=2.5V$ to $3.3V$, $V_{SS}=0V$

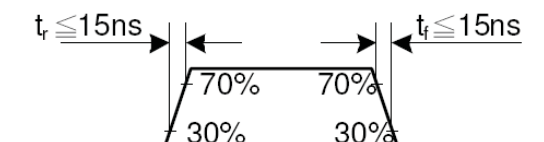

CSX timings :

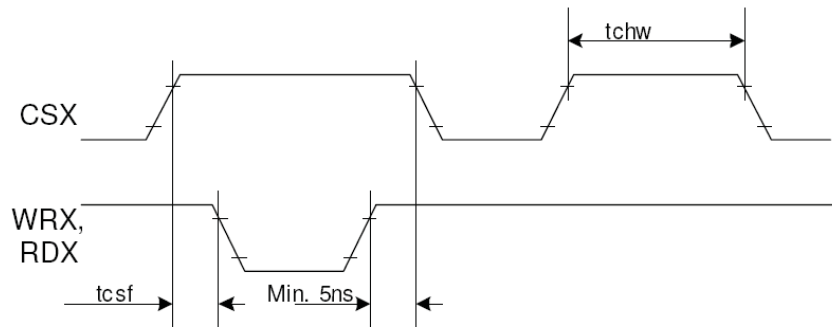

Note: Logic high and low levels are specified as 30% and 70% of VDDI for Input signals.

Write to read or read to write timings:

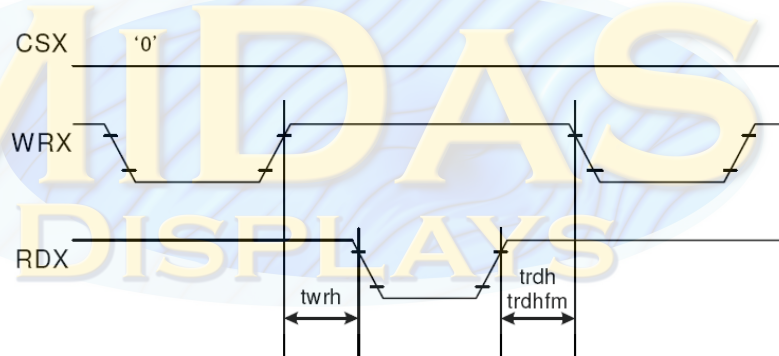

Note: Logic high and low levels are specified as 30% and 70% of VDDI for Input signals.

6.2 Display Parallel 18/16/9/8-bit Interface Timing Characteristics (8080-II system)

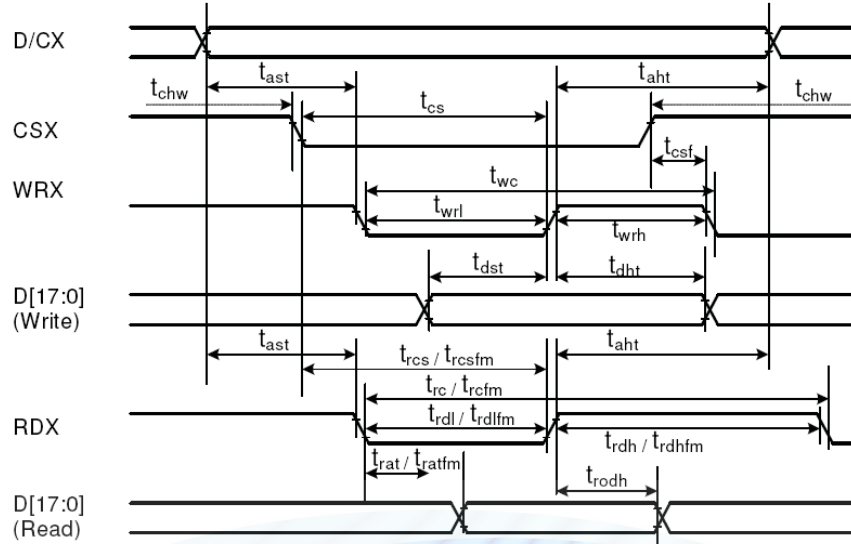

Signal	Symbol	Parameter	min	max	Unit	Description
DCX	t _{ast}	Address setup time	0	-	ns	
	t _{ah}	Address hold time (Write/Read)	0	-	ns	
CSX	t _{chw}	CSX "H" pulse width	0	-	ns	
	t _{cs}	Chip Select setup time (Write)	15	-	ns	
	t _{r_{cs}}	Chip Select setup time (Read ID)	45	-	ns	
	t _{r_{csfm}}	Chip Select setup time (Read FM)	355	-	ns	
WRX	t _{csf}	Chip Select Wait time (Write/Read)	10	-	ns	
	t _{wc}	Write cycle	66	-	ns	
	t _{wrl}	Write Control pulse L duration	15	-	ns	
RDX (FM)	t _{wrh}	Write Control pulse H duration	15	-	ns	
	t _{trcfm}	Read Cycle (FM)	450	-	ns	
	t _{trdhfm}	Read Control H duration (FM)	90	-	ns	
RDX (ID)	t _{trdlfm}	Read Control L duration (FM)	355	-	ns	
	t _{trc}	Read cycle (ID)	160	-	ns	
	t _{trdh}	Read Control pulse H duration	90	-	ns	
D[17:0], D[17:10]&D[8:1], D[17:10], D[17:9]	t _{trdl}	Read Control pulse L duration	45	-	ns	
	t _{tdst}	Write data setup time	10	-	ns	For maximum CL=30pF For minimum CL=8pF
	t _{tdht}	Write data hold time	10	-	ns	
	t _{trat}	Read access time	-	40	ns	
t _{tratfm}	Read access time	-	340	ns		
	t _{trod}	Read output disable time	20	80	ns	

Note: $T_a = -30$ to 70 °C, $V_{DDI}=1.65V$ to $3.3V$, $V_{CI}=2.5V$ to $3.3V$, $V_{SS}=0V$.

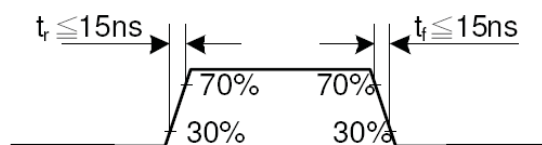

CSX timings :

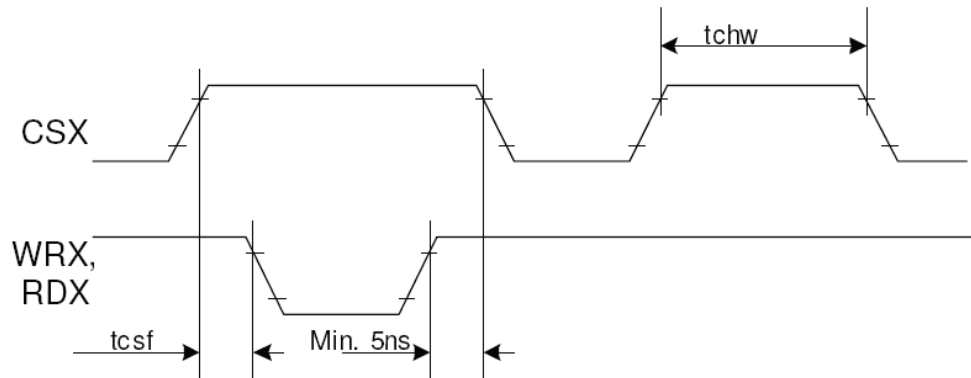

Note: Logic high and low levels are specified as 30% and 70% of VDDI for Input signals.

Write to read or read to write timings:

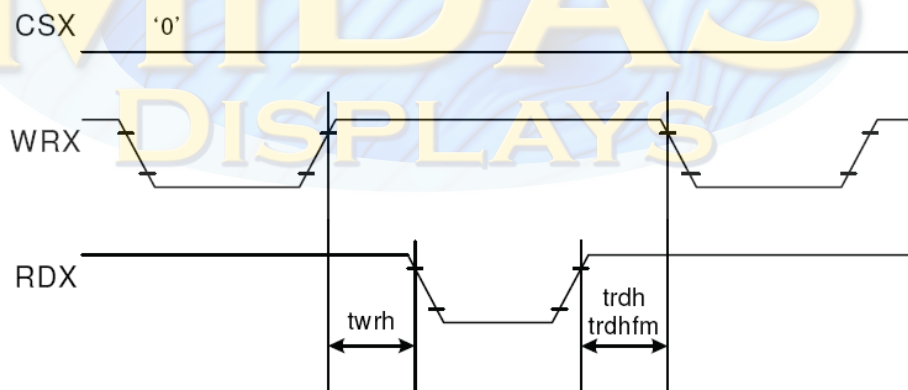

Note: Logic high and low levels are specified as 30% and 70% of VDDI for Input signals.

6.3 Display Serial Interface Timing Characteristics (3-line SPI system)

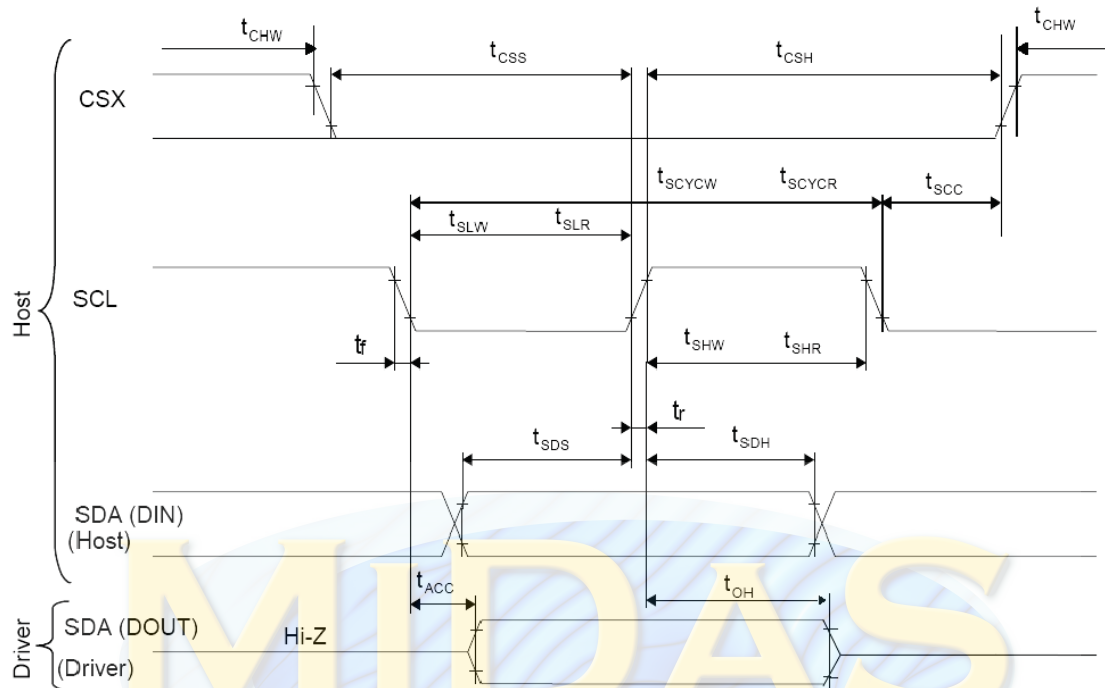

Signal	Symbol	Parameter	min	max	Unit	Description
SCL	tscycw	Serial Clock Cycle (Write)	100	-	ns	
	tshw	SCL "H" Pulse Width (Write)	40	-	ns	
	tslw	SCL "L" Pulse Width (Write)	40	-	ns	
	tscycr	Serial Clock Cycle (Read)	150	-	ns	
	tshr	SCL "H" Pulse Width (Read)	60	-	ns	
	tslr	SCL "L" Pulse Width (Read)	60	-	ns	
SDA / SDI (Input)	tsds	Data setup time (Write)	30	-	ns	
	tsdh	Data hold time (Write)	30	-	ns	
SDA / SDO (Output)	tacc	Access time (Read)	10	-	ns	
	toh	Output disable time (Read)	10	50	ns	
CSX	tsc	SCL-CSX	20	-	ns	
	tchw	CSX "H" Pulse Width	40	-	ns	
	tcss	CSX-SCL Time	60	-	ns	
	tcs		65	-	ns	

Note: $T_a = 25\text{ }^\circ\text{C}$, $V_{DDI}=1.65\text{V to }3.3\text{V}$, $V_{CI}=2.5\text{V to }3.3\text{V}$, $AGND=V_{SS}=0\text{V}$

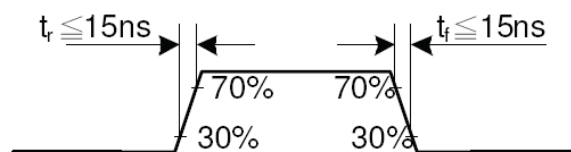

6.4 Display Serial Interface Timing Characteristics (4-line SPI system)

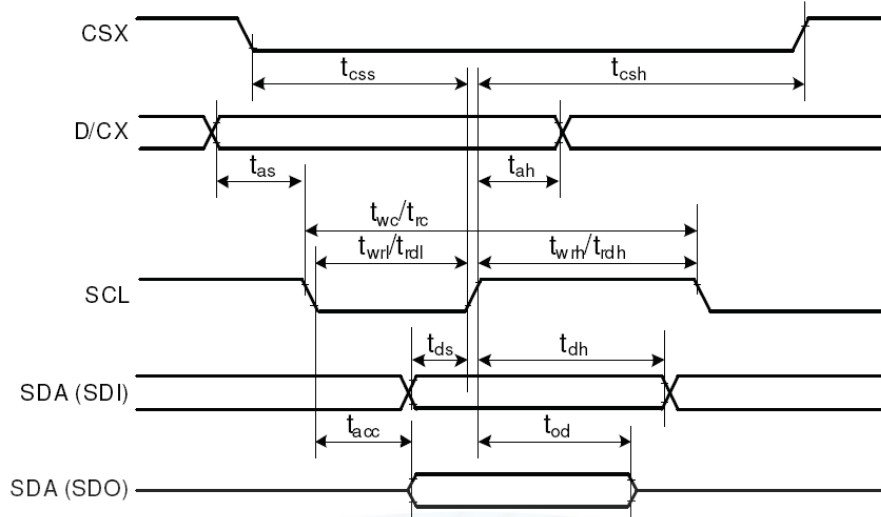

Signal	Symbol	Parameter	min	max	Unit	Description
CSX	t_{css}	Chip select time (Write)	40	-	ns	
	t_{csh}	Chip select hold time (Read)	40	-	ns	
SCL	t_{wc}	Serial clock cycle (Write)	100	-	ns	
	t_{wrh}	SCL "H" pulse width (Write)	40	-	ns	
	t_{wrl}	SCL "L" pulse width (Write)	40	-	ns	
	t_{rc}	Serial clock cycle (Read)	150	-	ns	
	t_{rdh}	SCL "H" pulse width (Read)	60	-	ns	
	t_{rdl}	SCL "L" pulse width (Read)	60	-	ns	
D/CX	t_{as}	D/CX setup time	10	-		
	t_{ah}	D/CX hold time (Write / Read)	10	-		
SDA / SDI (Input)	t_{ds}	Data setup time (Write)	30	-	ns	
	t_{dh}	Data hold time (Write)	30	-	ns	
SDA / SDO (Output)	t_{acc}	Access time (Read)	10	-	ns	For maximum $CL=30pF$
	t_{od}	Output disable time (Read)	10	50	ns	For minimum $CL=8pF$

Note: $T_a = 25\text{ }^\circ\text{C}$, $V_{DDI}=1.65\text{V to }3.3\text{V}$, $V_{CI}=2.5\text{V to }3.3\text{V}$, $AGND=VSS=0\text{V}$

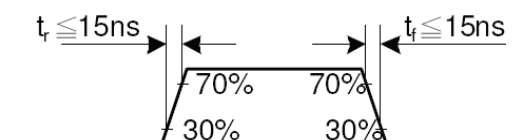

6.5 Parallel 18/16/6-bit RGB Interface Timing Characteristics

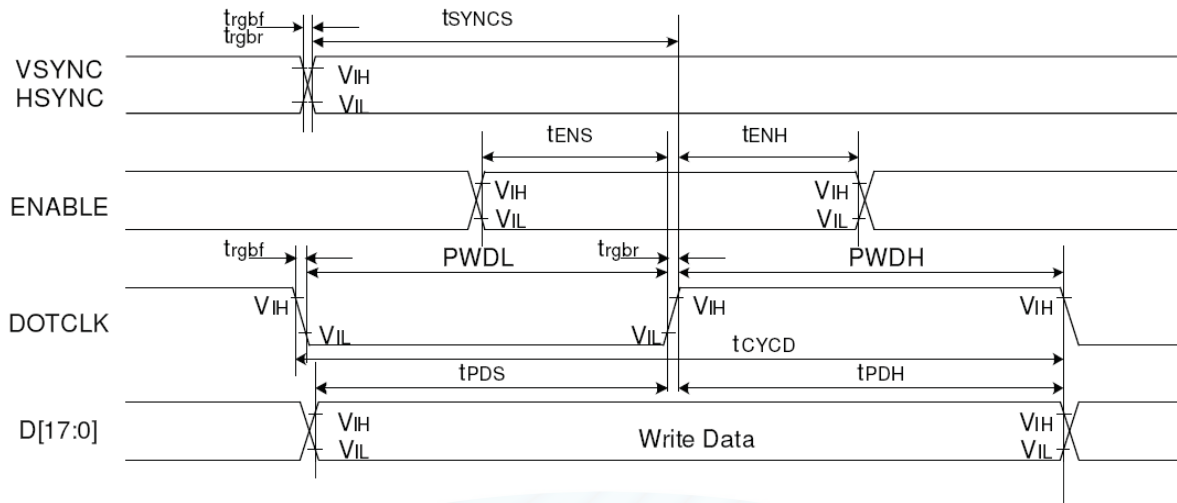

Signal	Symbol	Parameter	min	max	Unit	Description	
VSYNC / HSYNC	t_{SYNCS}	VSYNC/HSYNC setup time	15	-	ns	18/16-bit bus RGB interface mode	
	t_{SYNCH}	VSYNC/HSYNC hold time	15	-	ns		
DE	t_{ENS}	DE setup time	15	-	ns		
	t_{ENH}	DE hold time	15	-	ns		
D[17:0]	t_{POS}	Data setup time	15	-	ns		
	t_{PDH}	Data hold time	15	-	ns		
DOTCLK	PWDH	DOTCLK high-level period	15	-	ns		
	PWDL	DOTCLK low-level period	15	-	ns		
	t_{CYCD}	DOTCLK cycle time	100	-	ns		
	t_{rgbr}, t_{rgbf}	DOTCLK,HSYNC,VSYNC rise/fall time	-	15	ns		
VSYNC / HSYNC	t_{SYNCS}	VSYNC/HSYNC setup time	15	-	ns		6-bit bus RGB interface mode
	t_{SYNCH}	VSYNC/HSYNC hold time	15	-	ns		
DE	t_{ENS}	DE setup time	15	-	ns		
	t_{ENH}	DE hold time	15	-	ns		
D[17:0]	t_{POS}	Data setup time	15	-	ns		
	t_{PDH}	Data hold time	15	-	ns		
DOTCLK	PWDH	DOTCLK high-level pulse period	15	-	ns		
	PWDL	DOTCLK low-level pulse period	15	-	ns		
	t_{CYCD}	DOTCLK cycle time	100	-	ns		
	t_{rgbr}, t_{rgbf}	DOTCLK,HSYNC,VSYNC rise/fall time	-	15	ns		

Note: $T_a = -30$ to 70 °C, $V_{DDI} = 1.65V$ to $3.3V$, $V_{CI} = 2.5V$ to $3.3V$, $AGND = VSS = 0V$

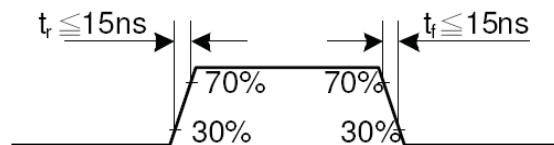

6.6 Controller Information

IC: ILI9341

7. OPTICAL CHARACTERISTICS

Item	Symbol	Condition	Specification			Unit	Remark
			Min.	Typ.	Max.		
Response time (By Quick)	Tr+Tf	$\theta = 0^\circ$	-	30	-	ms	Note 5
Contrast ratio	CR	$\theta = 0^\circ$	-	250	-		Note 2,6
Viewing angle	Top	$CR \geq 10$	-	45	-	deg.	Note 2,6,7
	Bottom	$CR \geq 10$	-	20	-		
	Left	$CR \geq 10$	-	45	-		
	Right	$CR \geq 10$	-	45	-		
CF Color chromaticity(CIE 1931)	Wx	$\theta = 0^\circ$	0.288	0.308	0.328		Note 3
	Wy		0.305	0.325	0.345		
	Rx		0.592	0.612	0.632		
	Ry		0.309	0.329	0.349		
	Gx		0.279	0.299	0.319		
	Gy		0.547	0.567	0.587		
	Bx		0.124	0.144	0.164		
	By		0.090	0.110	0.130		
NTSC				55%		Note 3	
Cross talk	ct				2%	Note 10	
Transmittance	Trans		4.5%	5.0%	-	Note 4	

Note 1: Ambient temperature = 25°C.

Note 2: To be measured with a viewing cone of 2° by Topcon luminance meter BM-5A.

Note 3: To be measured with Otsuta chromaticity meter LCF-2100M, CF only measure under C light simulation.

Note 4: CTC shipping status is cell without polarizer. Transmittance of Specification is cell with polarizer

Note 5: Definition of response time:

The output signals of TRD-100 are measured when the input signals are changed to "White" (falling time) and from "White" to "Black" (rising time), respectively. The interval is between the 10% and 90% of amplitudes. Refer to figure as below.

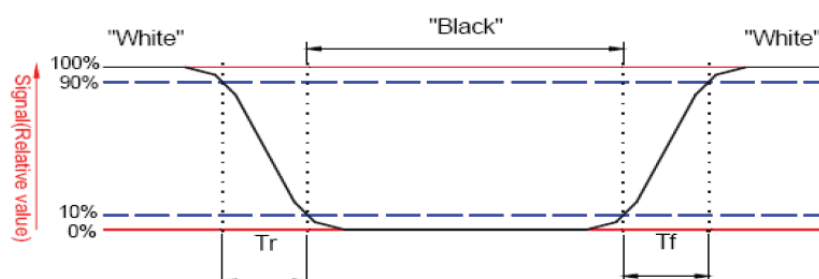

Note 6: Definition of contrast ratio:

Contrast ratio is calculated by the following formula.

$$\text{Contrast ratio (CR)} = \frac{\text{Brightness on the "white" state}}{\text{Brightness on the "black" state}}$$

Note 7: Definition of viewing angle

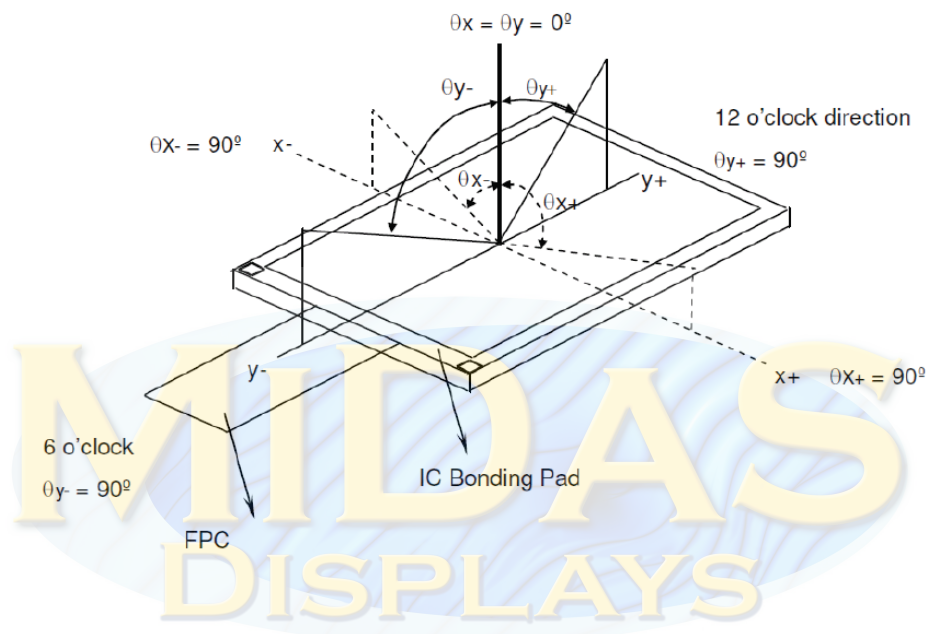

Note 8: Optical characteristic measurement setup.

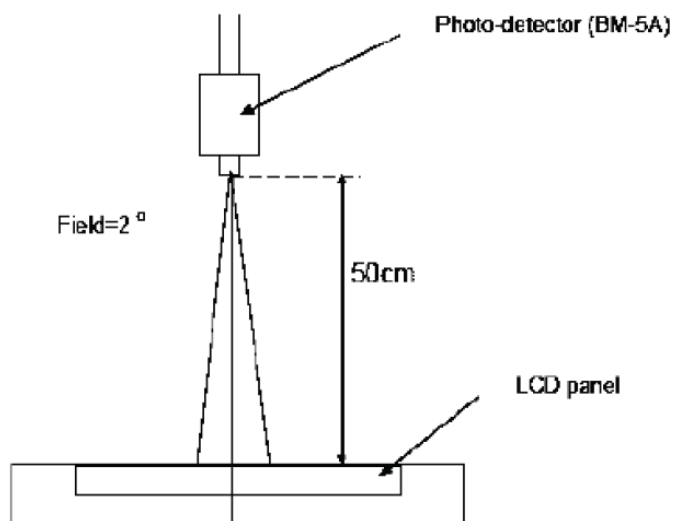

Note 9: Crosstalk.

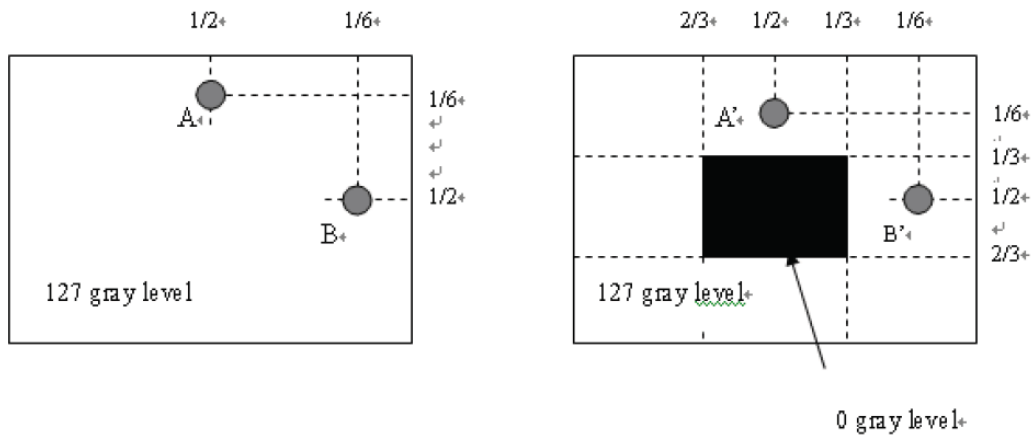

$|LA - LA'| / LA \times 100\% = 2\% \text{ max.}$, LA and LA' are brightness at location A and A'
 $|LB - LB'| / LB \times 100\% = 2\% \text{ max.}$, LB and LB' are brightness at location B and B'

MIDAS
DISPLAYS

12. PACKAGE

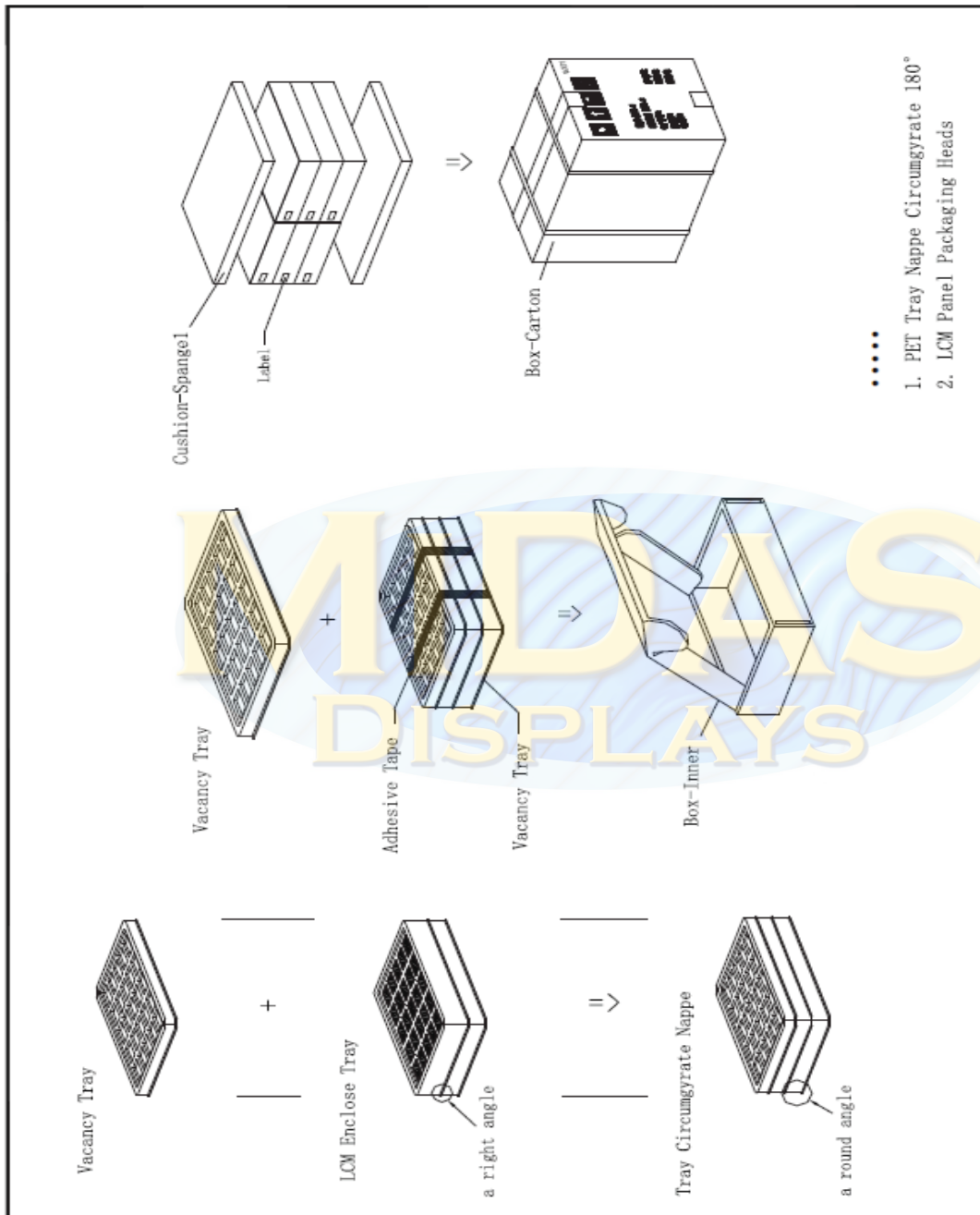

X-ON Electronics

Largest Supplier of Electrical and Electronic Components

Click to view similar products for [midas](#) manufacturer:

Other Similar products are found below :

[MCT070LA12W1024600LML](#) [MCOT128064BY-WM](#) [MCOB21609AV-EWP](#) [MC42004A6W-SPTLY](#) [MC22008B6W-SPR](#)
[MCT035G12W320240LML](#) [MC11605A6WR-SPTLY-V2](#) [MC21605H6W-BNMLW-V2](#) [MCOT048064A1V-YI](#)
[MCT101E0CW1280800LMLIPS](#) [MCT104A0W1024768LML](#) [MCT070Z0W800480LML](#) [MCT0144C6W128128PML](#) [MCIB-16-LVDS-CABLE](#) [MC41605A6W-FPTLA-V2](#) [MCOT128064UA1V-WM](#) [MCT101E0TW1280800LMLIPS](#) [MCT150B0W1024768LML](#)
[MCT050HDMI-A-RTP](#) [MCT050HDMI-A-CTP](#) [MCT070Z0TW1W800480LML](#) [MCT050ACA0CW800480LML](#) [MC42008A6W-SPTLY](#)
[MC42005A12W-VNMLY](#) [MC42005A12W-VNMLG](#) [MCT052A6W480128LML](#) [MC21605A6WK-BNMLW-V2](#) [MCOT256064A1A-BM](#)
[MCOT22005A1V-EYM](#) [MC20805A12W-VNMLG](#) [MC21605B6WD-BNMLW-V2](#) [MC22405A6WK-BNMLW-V2](#) [MC41605A6WK-FPTLW-V2](#) [MCT101HDMI-A-RTP](#) [MCT024L6W240320PML](#) [MCCOG21605D6W-FPTLWI](#) [MC21605A6WD-SPTLY-V2](#)
[MC22005A6WK-BNMLW-V2](#) [MC24005AA6W9-BNMLW-V2](#) [MC42004A6WK-SPTLY-V2](#) [MC11609A6W-SPTLY-V2](#)
[MCOT064048A1V-YM](#) [MCOT128064BY-BM](#) [MCCOG128064B12W-FPTLRGB](#) [MC11609A6W-SPR-V2](#) [MC21605H6WK-BNMLW-V2](#)
[MCOT128064E1V-BM](#) [MCT070HDMI-B-RTP](#) [MDT5000C](#) [MCCOG42005A6W-BNMLWI](#)