

HART® SNAP I/O Modules

Features

- Channel-to-channel isolation
- Rugged packaging and convenient pluggable wiring. Accepts up to 14 AWG wire.
- Factory calibrated; no user adjustment necessary
- Communicates digitally with HART current loop devices

Description

HART® SNAP I/O modules for analog current input and output provide communication with other Highway Addressable Remote Transducer (HART) current loop devices.

Each channel on each module features an integrated HART modem that allows the channel to communicate digitally with a HART FSK (frequency-shift keying) signal superimposed onto the analog 4–20 mA current loop. The channel is a master device when used together with SNAP PAC brains or controllers to communicate with other HART current loop devices in either point-to-point or multidrop configurations.

Current input and output modules are available. Both provide channel-to-channel isolation and are factory calibrated.

SNAP-AIMA-iH Input Module

The SNAP-AIMA-iH provides two channels of isolated analog input current with a range of 4–20 mA. External loop power supplies are required for current loops.

The SNAP-AIMA-iH is categorized by the HART protocol as a current input connection type, which means that the module is a low impedance device.

SNAP-AOA-23-iH Output Module

The SNAP-AOA-23-iH provides two channels of isolated analog output current with a range of 4–20 mA. External loop power supplies are required for current loops.

The SNAP-AOA-23-iH is categorized by the HART protocol as a current output device, which means that each channel controls the loop current and is a high impedance device.

Isolation

All SNAP analog modules are transformer isolated as well as optically isolated from all other modules and from the I/O processor. In addition, the modules in this data sheet have all channels isolated from each other. Channel-to-channel



isolation gives you complete freedom from ground-loop problems even on grounded devices connected to channels on the same module.

Transformer isolation prevents ground loop currents from flowing between field devices and causing noise that produces erroneous readings. Ground loop currents are caused when two grounded field devices share a connection, and the ground potential at each device is different.

Transformer isolation provides 1500 volts of transient (1500 V for 1 s) protection for control electronics from industrial field signals.

Using HART SNAP I/O Modules

HART SNAP I/O modules are part of the SNAP PAC System. They mount on SNAP PAC racks alongside other SNAP I/O modules (analog, digital, and serial), so you have the combination of I/O you need at any location. As shown in the diagram on the following page, the SNAP PAC I/O unit can communicate over a standard Ethernet network to databases, HMIs, and other devices.

These modules require a SNAP PAC brain or rack-mounted controller for I/O processing and communications. They are not compatible with legacy brains and controllers.

HART SNAP I/O modules are designed for use with a SNAP PAC programmable automation controller and PAC Control automation software. Several HART-specific PAC Control commands (available in PAC Control version 9.4 and higher)

Part Numbers

Part	Description
SNAP-AIMA-iH	Isolated two-channel analog current input, HART communication, 4–20 mA
SNAP-AOA-23-iH	Isolated two-channel analog current output, HART communication, 4–20 mA

HART® SNAP I/O Modules

make it possible for these modules to communicate any HART command that adheres to the HART request-response model or the burst message model.

In your PAC Control strategy you will need to assemble all request data sent to the module and to parse all response data returned by the module. In this way the modules can communicate with any wired HART device using any HART command.

For details and examples on all PAC Control commands, see form 1701, the *PAC Control Command Reference*, available at www.opto22.com.

The HART-specific PAC Control commands include:

- Get HART Unique Address
- Send/Receive HART Command
- Receive HART Command
- Receive HART Command Burst

In addition, the following string commands (also in PAC Control version 9.4 and higher) should be useful:

- Pack Float into String
- Pack Integer 32 into String
- Pack Integer 64 into String
- Pack String into String
- Unpack String

LEDs

Each module includes four LED indicators on the top of the module. LEDs 1 and 3 refer to channel 0; LEDs 2 and 4 refer to channel 1.

LED 1 or 2 Status	LED 3 or 4 Activity	Description
Solid Green	Blinking Green	HART channel is operational; loop voltage and current are within limits.
Solid Red	Blinking Red	HART communication error: <ul style="list-style-type: none"> • On a SNAP-AOA-23-iH, check loop voltage. Excessive load resistance or an incorrect loop power supply may cause voltage to be too low. • On a SNAP-AIMA-iH, check loop current to make sure it is between 3.9 mA and 20.2 mA. NOTE: If loop voltage and current are correct, contact Product Support.
OFF	--	Current loop open or loop voltage is zero. Implies that the channel is not being used.

System Architecture - HART SNAP I/O Modules

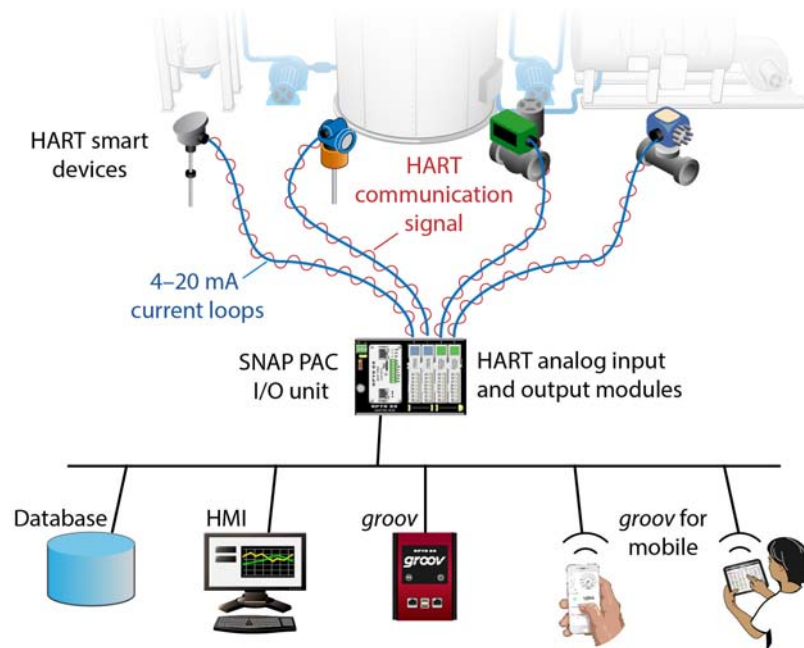

HART Developer Toolkit

HART SNAP I/O modules can also be used without PAC Control. Opto 22 offers the SNAP PAC .NET HART developer toolkit so you can easily integrate HART SNAP I/O modules into an existing .NET/Mono application.

This toolkit is available for download at www.opto22.com.

HART® SNAP I/O Modules

Specifications: SNAP-AIMA-iH

Input Range Nominal Full	4 to 20 mA 3.2 to 24 mA
Maximum Survivable Input	40 V or 160 mA
Impedance	230 Ohms nominal
Resolution	0.8 microamps
Accuracy	+/- 10 microamps
Response Time (% of span/delta I/delta time)	99.9%/20.7mA/10 ms
Gain Temperature Coefficient	30 ppm/ °C
Offset Temperature Coefficient	15 ppm/ °C
DC Common Mode Rejection	>-120 dB
AC Common Mode Rejection	>-120 dB @ 60 Hz
Maximum Operating Common Mode Voltage	250 V continuous 1500 V transient (1 s)
Isolation: Channel-Channel	250 V continuous 1500 V transient (1 s)
Power Requirements	5 VDC (+/- 0.15) @ 150 mA
Ambient Temperature: Operating Storage	-20 °C to 70 °C -40 °C to 85 °C
Torque, hold-down screws	4 in-lb (0.45 N-m)
Torque, connector screws	5.26 in-lb (0.6 N-m)
Agency Approvals	CE, RoHS, DFARS
Warranty	Lifetime

Specifications: SNAP-AOA-23-iH

Output Range Nominal Full	4 to 20 mA 3.2 to 24 mA
External Loop Voltage Range Nominal	12-36 VDC 24 VDC
Maximum Load Resistance at Specified Loop Voltage 12 VDC 24 VDC 36 VDC	300 Ohms 850 Ohms 1350 Ohms
Resolution	5 microamps
Accuracy	+/- 20 microamps
Response Time (% of span/delta I/delta time)	99.9%/20.7 mA/400 ms
Gain Temperature Coefficient	-50 ppm/ °C
Offset Temperature Coefficient	-25 ppm/ °C
DC Common Mode Rejection	>-120 dB
AC Common Mode Rejection	>-120 dB @ 60 Hz
Maximum Operating Common Mode Voltage	250 V continuous 1500 V transient (1 s)
Common Mode Resistance	>1000 megohms
Isolation: Channel-Channel	250 V continuous 1500 V transient (1 s)
Power Requirements	5 VDC (+/- 0.15) @ 150 mA
Ambient Temperature: Operating Storage	-20 °C to 70 °C -40 °C to 85 °C
Torque, hold-down screws	4 in-lb (0.45 N-m)
Torque, connector screws	5.26 in-lb (0.6 N-m)
Agency Approvals	CE, RoHS, DFARS
Warranty	Lifetime

Wiring Diagrams - SNAP HART Modules

SNAP-AIMA-iH

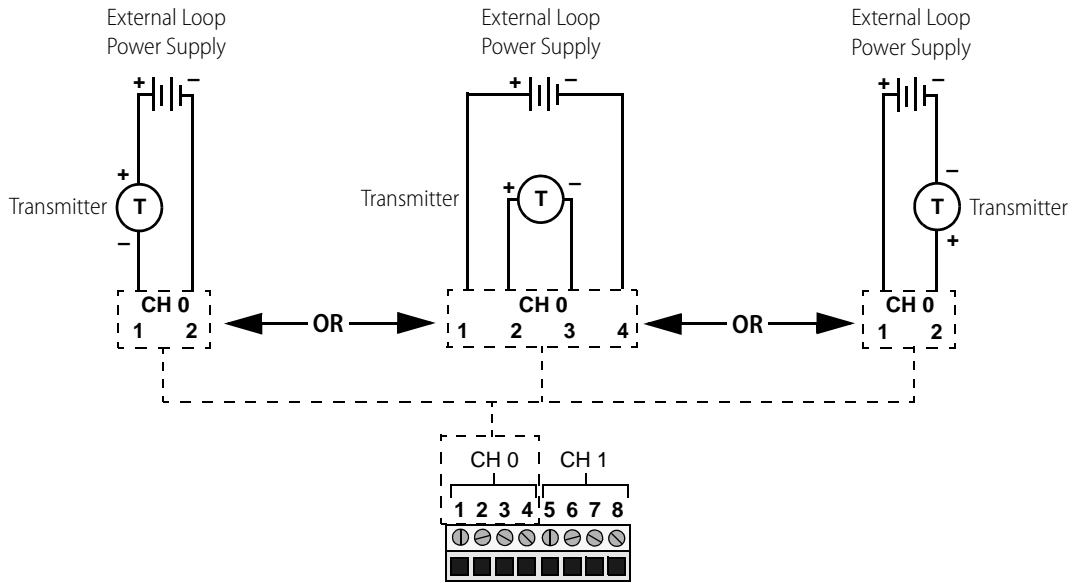

SNAP-AOA-23-iH

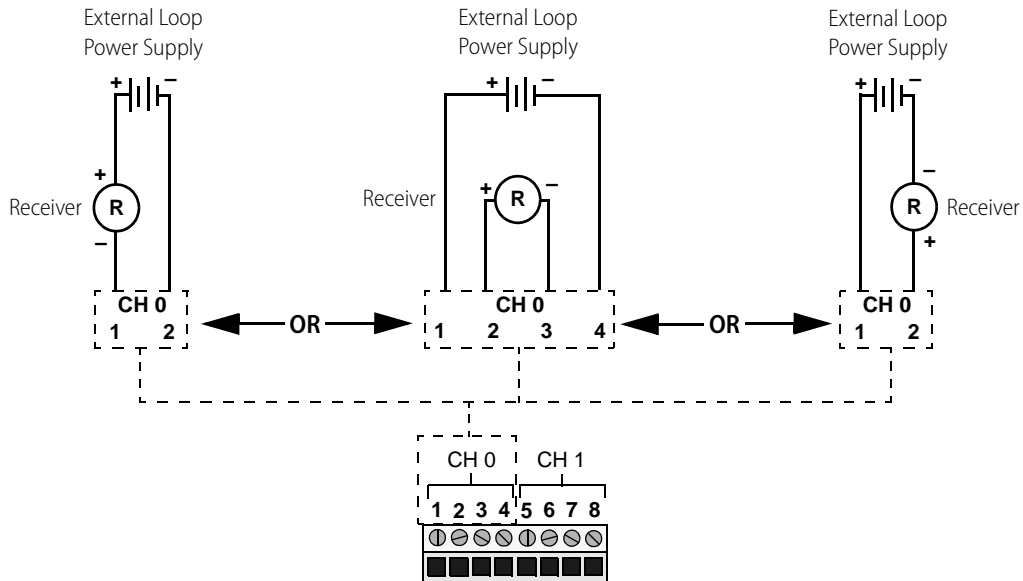

HART® SNAP I/O Modules

Wiring Diagrams (continued)

Wiring shown on the previous page is typical use.

The wiring on this page is nonstandard. **Use this page if:**

- You are using the HART protocol but not using the analog signal.
- Your HART network includes too many devices for a standard 4–20 mA loop.

This alternative wiring makes sure all HART devices on your network have adequate power.

Multidrop Wiring—SNAP-AIMA-iH

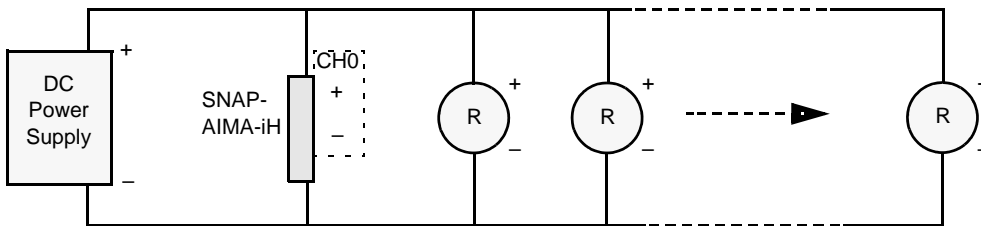

Multidrop Wiring—SNAP-AOA-23-iH

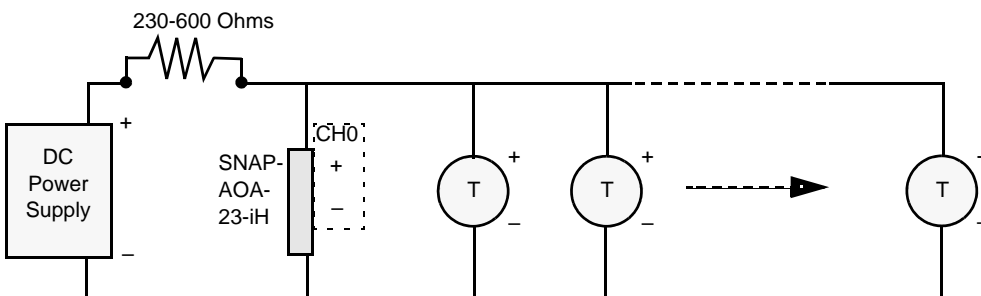

Dimensional Drawings

TOP VIEW OF MODULE

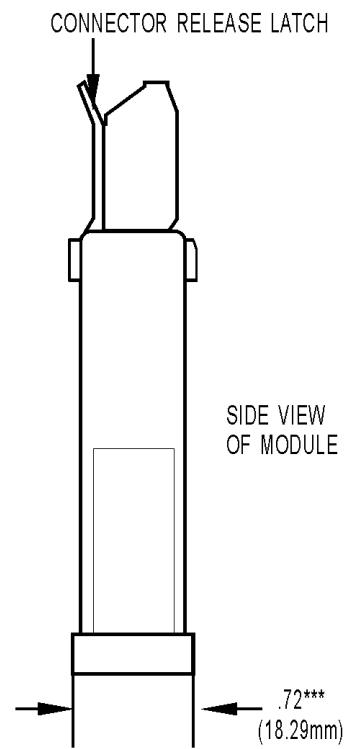
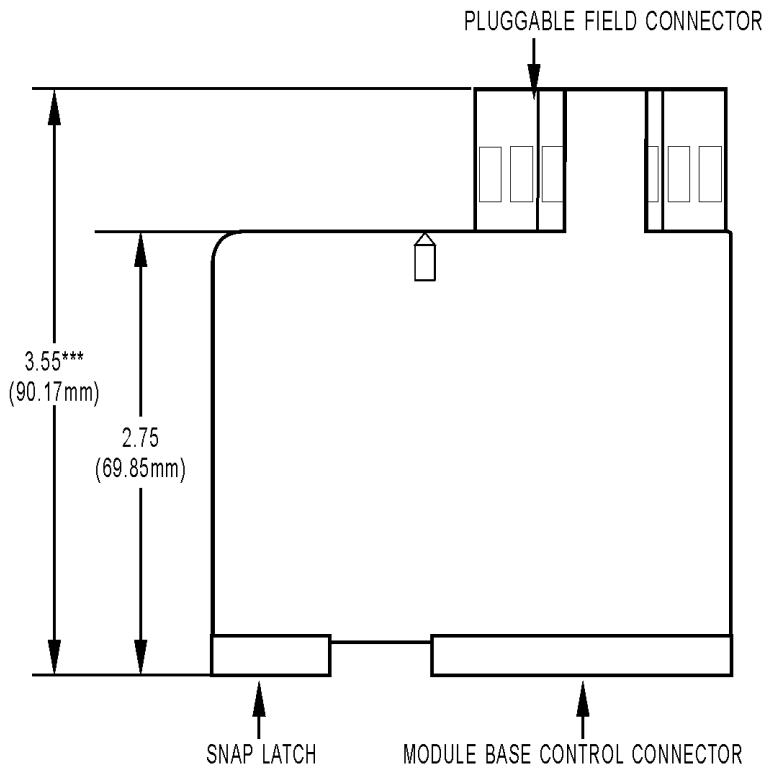
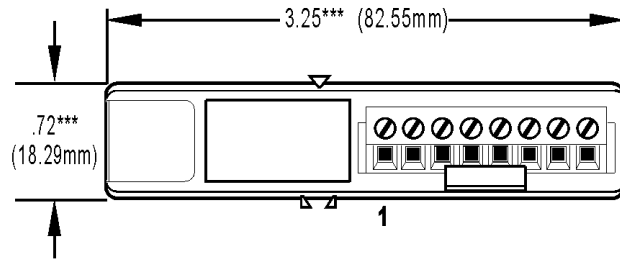

TOLERANCES LEGEND

- * +/- .010"
- ** +/- .020"
- *** +/- .030"
- **** +/- .060"
- NO * REFERENCE ONLY

HART® SNAP I/O Modules

Dimensional Drawings

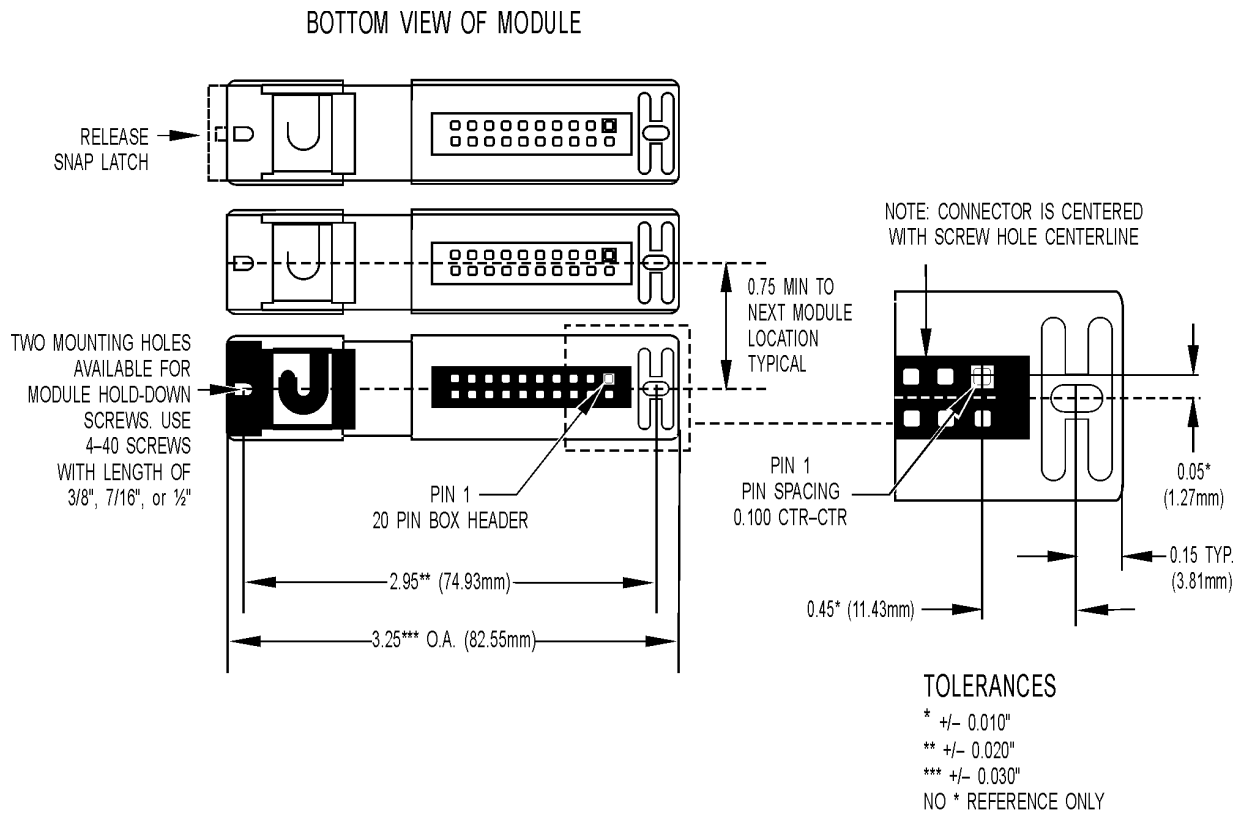

IMPORTANT: The mounting rack connector has 24 pins; the module connector has 20 pins. The extra pins on the mounting rack connector prevent misalignment of the module during installation.

More About Opto 22

Products

Opto 22 develops and manufactures reliable, flexible, easy-to-use hardware and software products for industrial automation, energy management, remote monitoring, and data acquisition applications.

groov

groov puts your system on your mobile device. With zero programming, you can build mobile operator interfaces to monitor and control systems from Allen-Bradley, Siemens, Schneider Electric, Modicon, and many more. Web-based groov puts mobile-ready gadgets at your fingertips. Tag them from your existing tag database, and they automatically scale for use on any device with a modern web browser. See groov.com for more information and your free trial.

SNAP PAC System

Designed to simplify the typically complex process of selecting and applying an automation system, the SNAP PAC System consists of four integrated components:

- SNAP PAC controllers
- PAC Project™ Software Suite
- SNAP PAC brains
- SNAP I/O™

SNAP PAC Controllers

Programmable automation controllers (PACs) are multifunctional, modular controllers based on open standards.

Opto 22 has been manufacturing PACs for over two decades. The standalone SNAP PAC S-series, the rack-mounted SNAP PAC R-series, and the software-based SoftPAC™ all handle a wide range of digital, analog, and serial functions for data collection, remote monitoring, process control, and discrete and hybrid manufacturing.

SNAP PACs are based on open Ethernet and Internet Protocol (IP) standards, so you can build or extend a system easily, without the expense and limitations of proprietary networks and protocols. Wired+Wireless™ models are also available.

PAC Project Software Suite

Opto 22's PAC Project Software Suite provides full-featured, cost-effective control programming, HMI (human machine interface) development and runtime, OPC server, and database connectivity software for your SNAP PAC System.

Control programming includes both easy-to-learn flowcharts and optional scripting. Commands are in plain English; variables and I/O point names are fully descriptive.

PAC Project Basic offers control and HMI tools and is free for download on our website, www.opto22.com. PAC Project

Professional, available for separate purchase, adds one SoftPAC, OptoOPCServer, OptoDataLink, options for controller redundancy or segmented networking, and support for legacy Opto 22 serial *mistic*™ I/O units.

SNAP PAC Brains

While SNAP PAC controllers provide central control and data distribution, SNAP PAC brains provide distributed intelligence for I/O processing and communications. Brains offer analog, digital, and serial functions, including thermocouple linearization; PID loop control; and optional high-speed digital counting (up to 20 kHz), quadrature counting, TPO, and pulse generation and measurement.

SNAP I/O

I/O provides the local connection to sensors and equipment. Opto 22 SNAP I/O offers 1 to 32 points of reliable I/O per module, depending on the type of module and your needs. Analog, digital, and serial modules are all mixed on the same mounting rack and controlled by the same processor (SNAP PAC brain or rack-mounted controller).

Quality

Founded in 1974, Opto 22 has established a worldwide reputation for high-quality products. All are made in the U.S.A. at our manufacturing facility in Temecula, California. Because we test each product twice before it leaves our factory, rather than only testing a sample of each batch, we can guarantee most solid-state relays and optically isolated I/O modules for life.

Free Product Support

Opto 22's California-based Product Support Group offers free, comprehensive technical support for Opto 22 products. Our staff of support engineers represents decades of training and experience. Support is available in English and Spanish by phone or email, Monday–Friday, 7 a.m. to 5 p.m. PST.

Additional support is always available on our website: how-to videos, OptoKnowledgeBase, self-training guide, troubleshooting and user's guides, and OptoForums.

In addition, hands-on training is available for free at our Temecula, California headquarters, and you can [register online](#).

Purchasing Opto 22 Products

Opto 22 products are sold directly and through a worldwide network of distributors, partners, and system integrators. For more information, contact Opto 22 headquarters at 800-321-6786 or 951-695-3000, or visit our website at www.opto22.com.

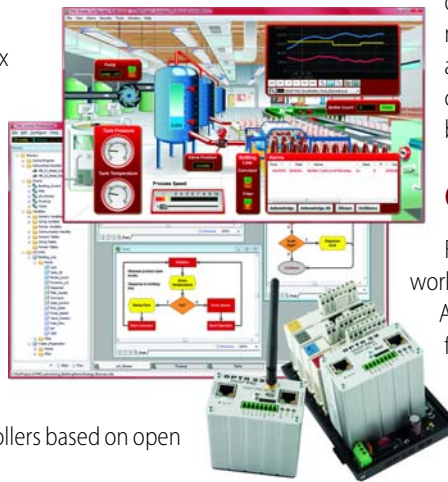

www.opto22.com

X-ON Electronics

Largest Supplier of Electrical and Electronic Components

Click to view similar products for [I/O Controller Interface IC](#) category:

Click to view products by [Opto 22](#) manufacturer:

Other Similar products are found below :

[CYDMX128B16-65BVXI](#) [DSL5110 SR1TY](#) [EC-GAV](#) [SCH5327B-NS](#) [SEC1210/PV-URT](#) [LPC47M287-NW](#) [SEC1210I-CN-02](#) [CP2108-B02-GM](#) [LPC47M107S-MS](#) [LPC47M102S-MS](#) [70M-OAC15A](#) [NCT6776D](#) [Z85C3010PSG](#) [Z84C4310AEG](#) [IS31IO7326-QFLS4-EB](#) [Z16C3010VEG](#) [JHL2210 S LL38](#) [MAX5940CESA+](#) [84115502](#) [SLO24IRA](#) [84145010](#) [20LPCV2415](#) [84130108](#) [SM-OAC5AR](#) [DS2483Q+T](#) [SEC1210I-CN-02-TR](#) [LPC47B277-MS](#) [JHL8010R S LMND](#) [KTI225V S LN9C](#) [JHL8040R S LMN6](#) [CP2109-A01-GMR](#) [MCP2140A-ISS](#) [MCP2155-IP](#) [MCP2140A-ISO](#) [SNAP-AIMA-8](#) [IAC5A](#) [Z84C1510AEG](#) [SCH5017-NW](#) [ODC5](#) [TDA8026ET/C2,518](#) [IAC5](#) [CP2112-F02-GMR](#) [CP2109-A01-GM](#) [LPC47M192-NW](#) [FDC37B787-NS](#) [FDC37C669-MS](#) [MCP2140-ISO](#) [73S8009CN-32IM/F](#) [MAX14824GTG+](#) [MAX14821ETG+](#)