

00 SERIES (NIM-CAMAC)

00 Series (NIM-CAMAC CD/N 549)

The 00 series is a range of 50 Ω coaxial connectors. They are suitable for a wide variety of applications particularly in measurement, control system and nuclear physics, having formed the basis for the NIM-CAMAC CD/N 549 standard. LEMO 00 connectors offer customers many benefits including:

- Self-latching push-pull system
- Aesthetically pleasing appearance
- Small size
- High packing density
- Rugged construction
- Ease of use
- Low weight
- Reliable performances
- Wide choice to suit application

Metal housing models (page 8)

Fixed plugs

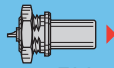

FAA

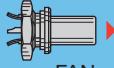

FAN



FAB

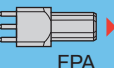

FPA

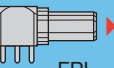

FPL

Elbow plugs



FLC



FLS, FLV

Straight plugs

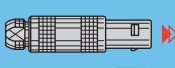

FFA

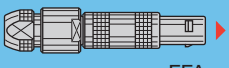

FFA



FFA

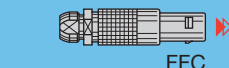

FFC

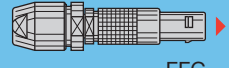

FFC

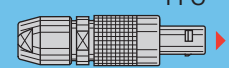

FFY

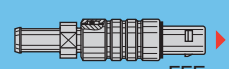

FFE

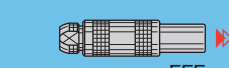

FFF

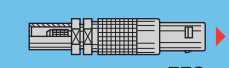

FFS

Fixed sockets



ERA, ERE



ERN



ERC



ERC



ERT



ERX



ECP



EHP



ELF



EPA, EPB, EPC



EPE

Elbow sockets

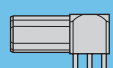

EPL, EPM, EPK, EPR



EPS

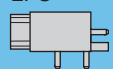

EPN



EPY



FRT



FLR



Socket with microswitch

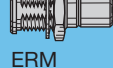

ERM

Free sockets



PCA

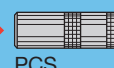

PCS

Fixed sockets

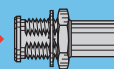

PSA

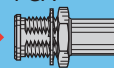

PSS

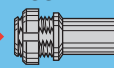

PES

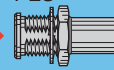

PFS

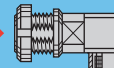

PLK

Fixed coupler

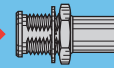

RAD



RMA

Straight and elbow plugs with socket

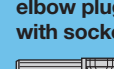

FTR



FTA

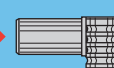

FTL



FTY

Plastic housing models* (page 21)

Straight plug

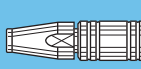

FFA

Fixed socket

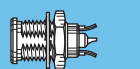

ERN

Threaded latching Models* (page 26)

Straight plug

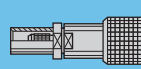

FVS

Adaptors

(See page 27)

Watertight or vacuumtight models (page 22)

Straight sockets



HGP



HGW



HEP



EWF



EWV



VPS

Straight coupler



SWH

Metal housing models with mechanical keying* (page 24)

Straight plug

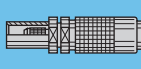

FSG

Elbow sockets

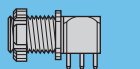

XBG

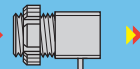

XRG

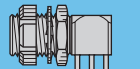

XSG

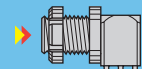

EXG

Fixed sockets

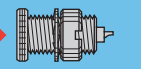

ESG

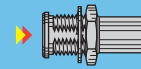

PSG

* not included in NIM-CAMAC standard

Part Numbering System

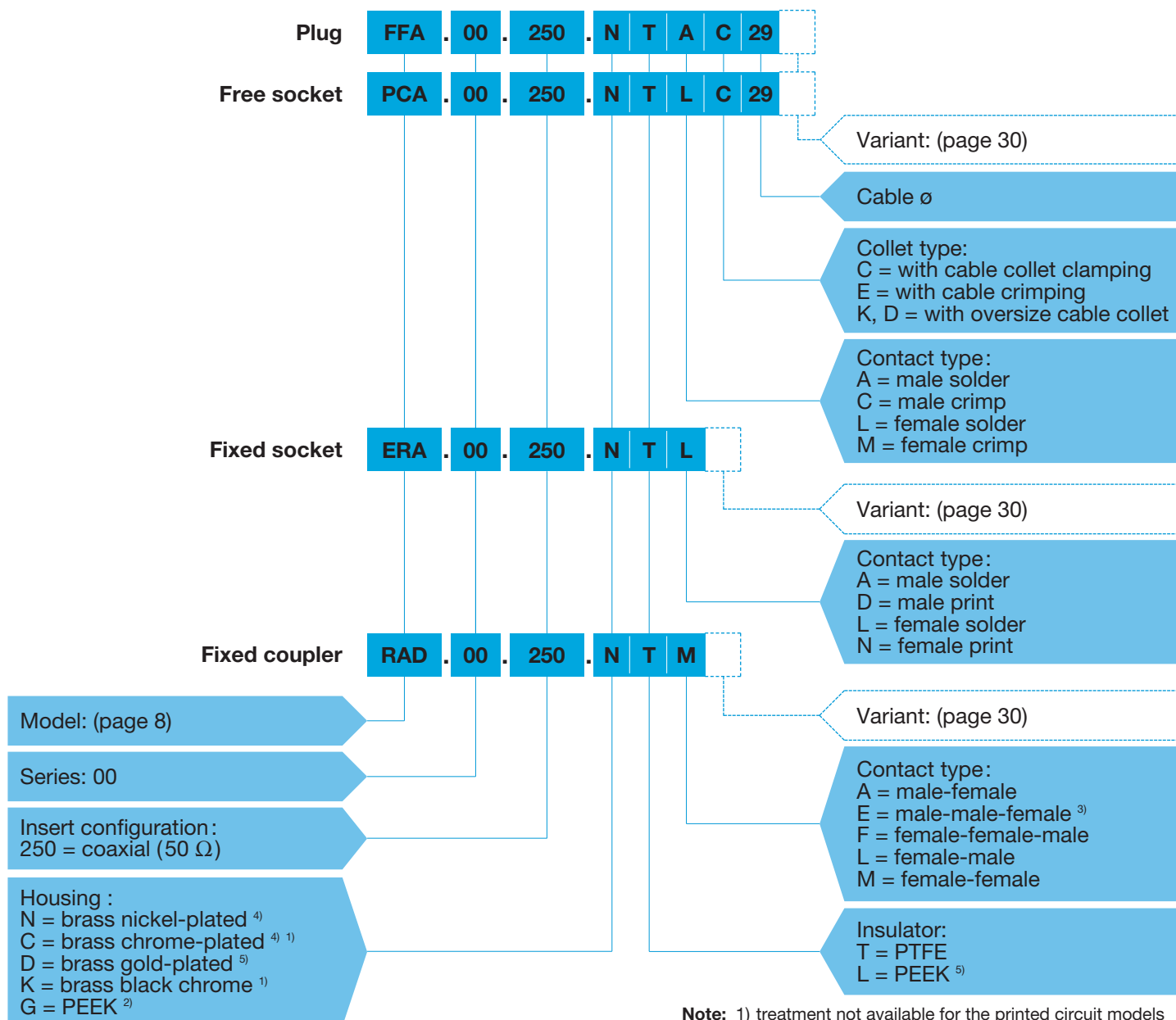

Note: 1) treatment not available for the printed circuit models
 2) available for the FFA and ERN model only
 3) used only for models: FTA, FTL and FTY.
 4) standard
 5) non-standard, on request only

Part Number Example

FFA.00.250.NTAC29 = straight plug with cable collet, series 00, coaxial type (50 Ω), outer shell in nickel-plated brass, PTFE insulator, male solder contact, C type collet of 2.9 mm diameter.

Part Section Showing Internal Components

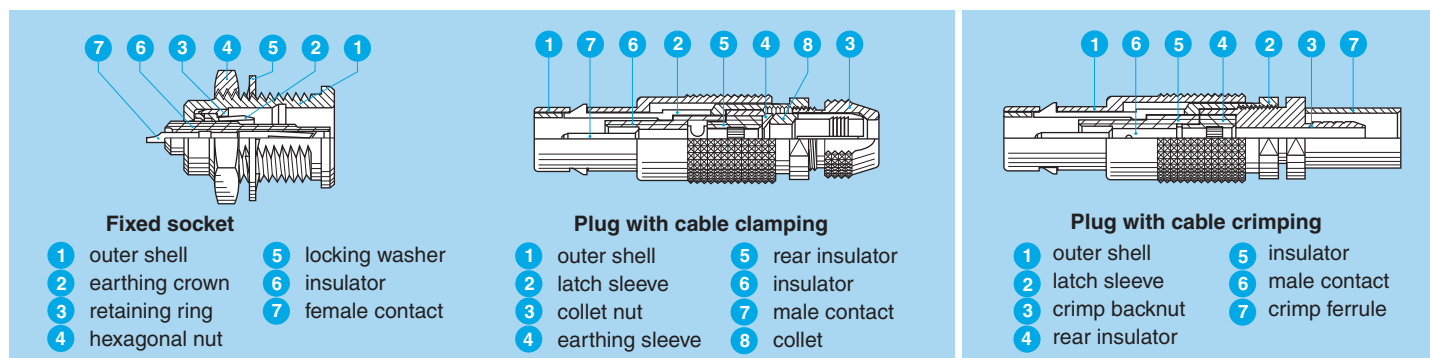



Metal housing models

Technical Characteristics

Mechanical and climatical

Characteristics	Value	Standard	Test
Contact retention force	> 18 N	IEC 60512-8	15a
Cable pull off force ¹⁾	> 100 N	IEC 60512-9	17c
Connector pull off force	> 90 N	IEC 60512-8	15f
Endurance	> 5000 cycles	IEC 60512-5	9a
Operating temperature	- 55°C + 260°C		

Note: ¹⁾ depending on cable design

Voltage Standing Wave Ratio

The VSWR (Voltage Standing Wave Ratio) is the value representing the power reflected in a connection. The VSWR varies with frequency, in most cases, the working frequency range is where VSWR is ≤ 1.25 .

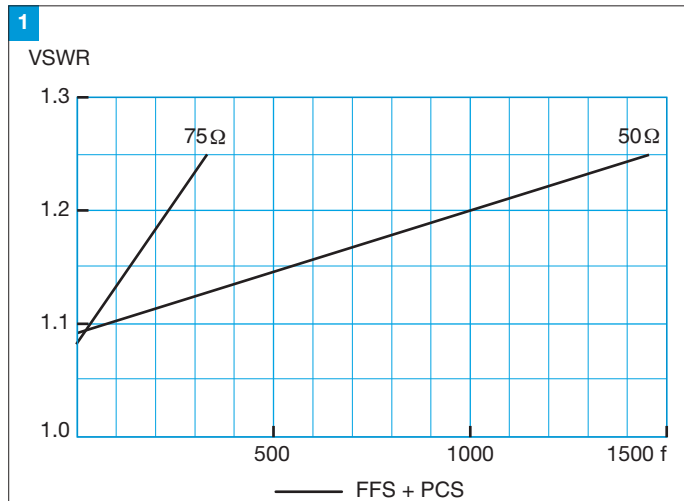

Note: value for connectors with PTFE insulator. VSWR measured 50 Ω with a RG-174 A/U cable and 75 Ω with a RG-179 B/U cable. Measured according to IEC-60169-1-1.

Electrical

Characteristics	Value	Standard	Test
Impedance	50 Ω	-	
Operating voltage (50 Hz)	0.7 kV rms	-	
Test voltage (50 Hz)	2.1 kV rms	IEC 60512-2	4a
Rated current	4 A	IEC 60512-3	5a
Contact resistance	< 6 mΩ	IEC 60512-2	2a
Shell electrical continuity	< 3.5 mΩ	IEC 60512-2	2f
Insulating resistance	> 10 ¹² Ω	IEC 60512-2	3a
VSWR	see chart N°1 below		
Shielding efficiency	see chart N°2 below		

Shielding efficiency (EMC properties) in dB (transfer impedance in dBΩm)

The shielding efficiency is the ratio between the electromagnetic field inside the connector and a power source at the outside of the connector (or vice versa).

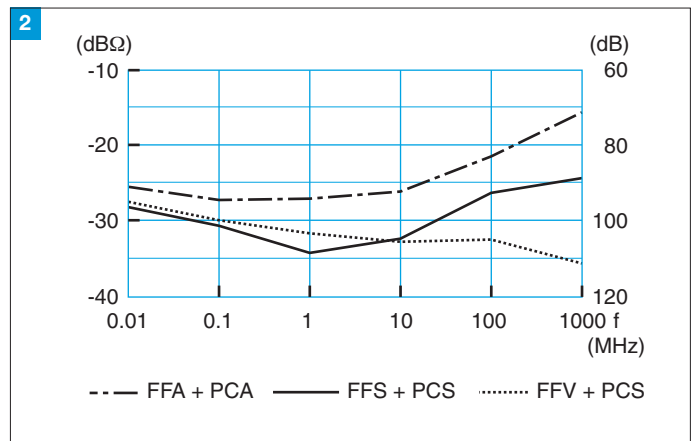

Note: measured according to IEC-60169-1-3 standard.

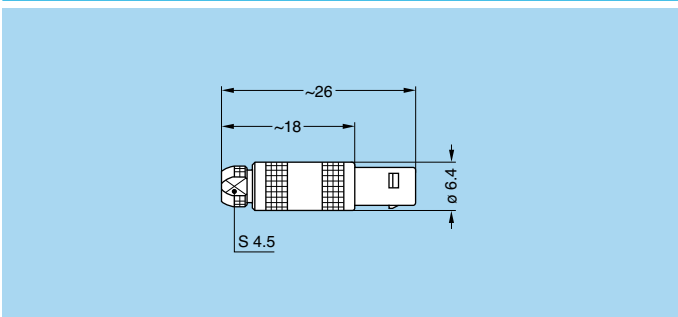
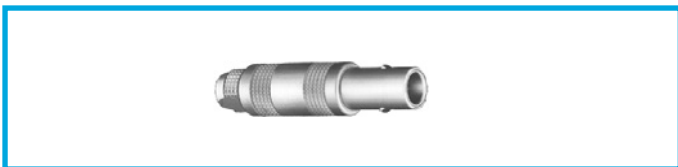

FFA Straight plug with cable collet

Part number	Cable group	Cond. Ø max.	Dielectric Ø max.	Sheath Ø	
				min.	max.
FFA.00.250.NTAC15	9	0.55	1.45	1.1	1.4
FFA.00.250.NTAC17	-	0.55	1.45	1.3	1.7
FFA.00.250.NTAC22	1	0.55	1.95	1.8	2.2
FFA.00.250.NTAC27	2-3-4	0.55	1.95	2.3	2.7
FFA.00.250.NTAC31	8	0.55	1.95	2.8	3.0

M1 Cable assembly, solder contact (page 39)

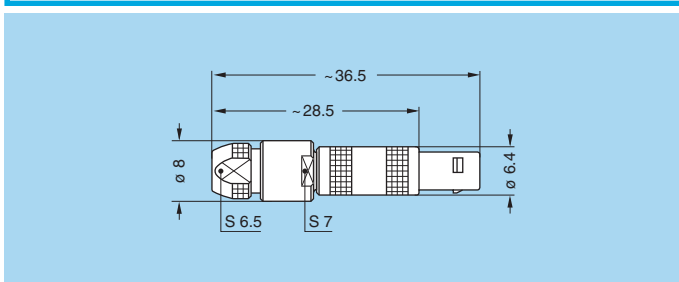

FFA Straight plug with oversize cable collet

Part number	Cable group	Cond. Ø max	Dielectric Ø maxi	Sheath Ø	
				mini	maxi
FFA.00.250.NTAK37	8	0.55	1.95	3.0	3.6
FFA.00.250.NTAK42	-	0.55	1.95	3.3	4.1

M1 Cable assembly, solder contact (page 39)

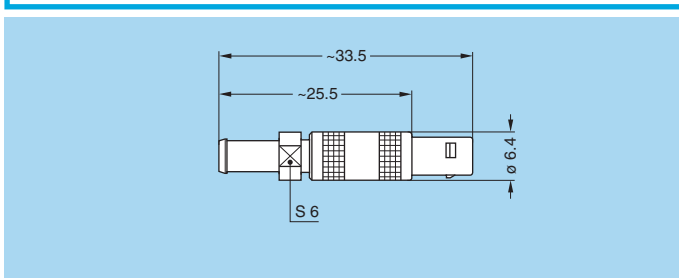
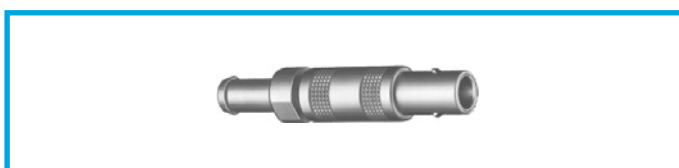

FFA Straight plug with cable collet and nut for fitting a bend relief

Part number	Cable group	Cond. Ø max	Dielectric Ø maxi	Sheath Ø	
				mini	maxi
FFA.00.250.NTAC15Z	9	0.55	1.45	1.1	1.4
FFA.00.250.NTAC17Z	-	0.55	1.45	1.3	1.7
FFA.00.250.NTAC22Z	1	0.55	1.95	1.7	2.1
FFA.00.250.NTAC27Z	2-3-4	0.55	1.95	2.3	2.7
FFA.00.250.NTAC31Z	8	0.55	1.95	2.8	3.0

M1 Cable assembly, solder contact (page 39)

Note: the bend relief must be ordered separately (see page 30).

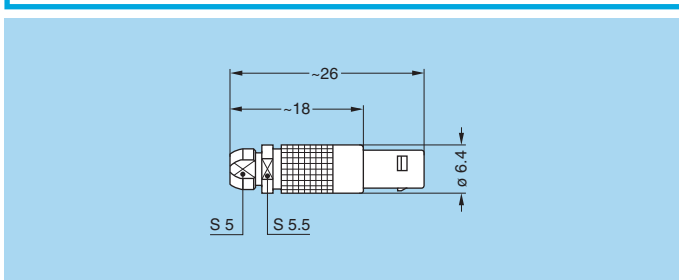
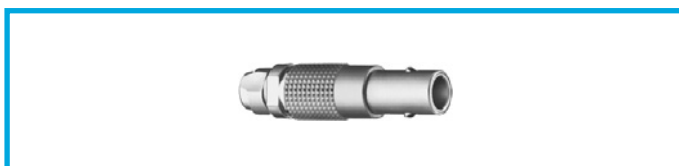

FFC Straight plug with flats on latch sleeve and cable collet

Part number	Cable group	Cond. Ø max	Dielectric Ø maxi	Sheath Ø	
				mini	maxi
FFC.00.250.CTAC22	1	0.60	1.55	1.7	2.1
FFC.00.250.CTAC27	2-3-4	0.60	1.95	2.3	2.7
FFC.00.250.CTAC31	8	0.60	1.95	2.8	3.0

M3 Cable assembly, solder contact (page 39)

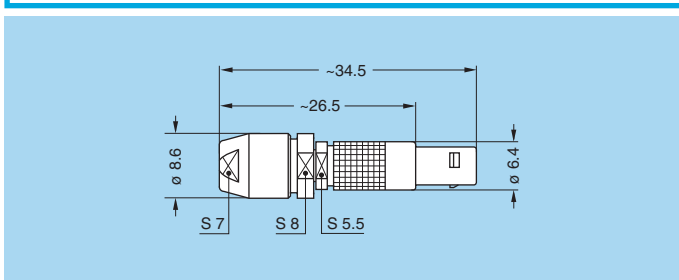
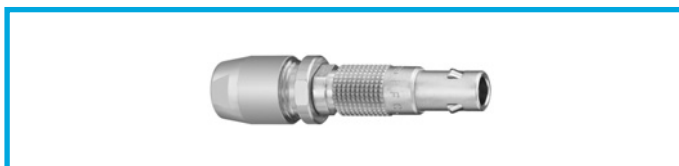

FFC Straight plug with flats on latch sleeve and oversize cable collet

Part number	Cable group	Cond. Ø max	Dielectric Ø maxi	Sheath Ø	
				mini	maxi
FFC.00.250.CTAD42	5	1.05	3.05	3.1	4.0
FFC.00.250.CTAD52	6-7	1.05	3.05	4.1	5.0
FFC.00.250.CTAD56	-	1.05	3.05	5.1	5.5

M3 Cable assembly, solder contact (page 39)

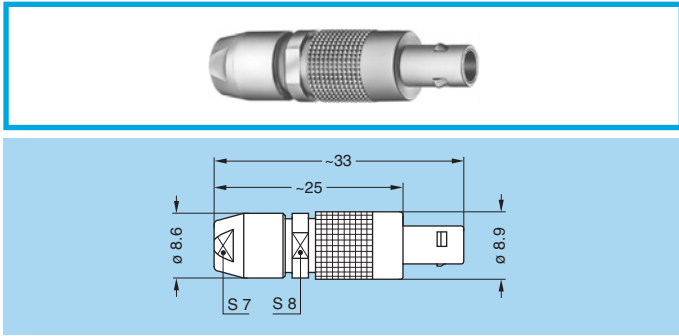

FFY Straight plug, large shell with cable collet

Part number	Cable group	Cond. Ø max	Dielectric Ø maxi	Sheath Ø	
				mini	maxi
FFY.00.250.NTAC40	5	1.05	3.05	3.2	3.8
FFY.00.250.NTAC47	–	1.05	3.05	3.9	4.5
FFY.00.250.NTAC52	6-7	1.05	3.05	4.6	5.0

M2 Cable assembly, solder contact (page 39)

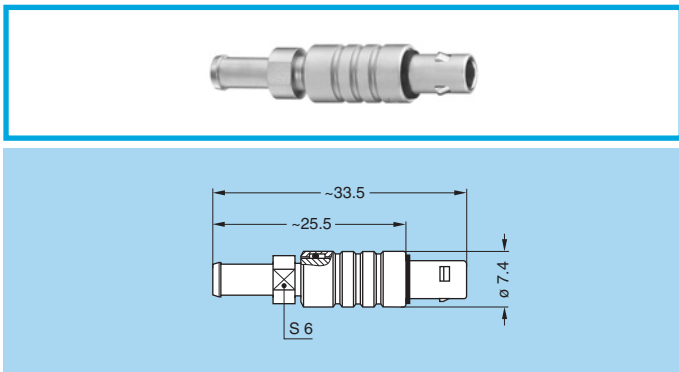

FFE Straight plug with front sealing ring, cable collet and nut for fitting a bend relief (IP 54 protection index when mated)

Part number	Cable group	Cond. Ø max	Dielectric Ø maxi	Sheath Ø	
				mini	maxi
FFE.00.250.NTAC22Z	1	0.55	1.95	1.7	2.1
FFE.00.250.NTAC27Z	2-3-4	0.55	1.95	2.3	2.7
FFE.00.250.NTAC31Z	8	0.55	1.95	2.8	3.0

M1 Cable assembly, solder contact (page 39)

Note: the bend relief must be ordered separately (see page 30).

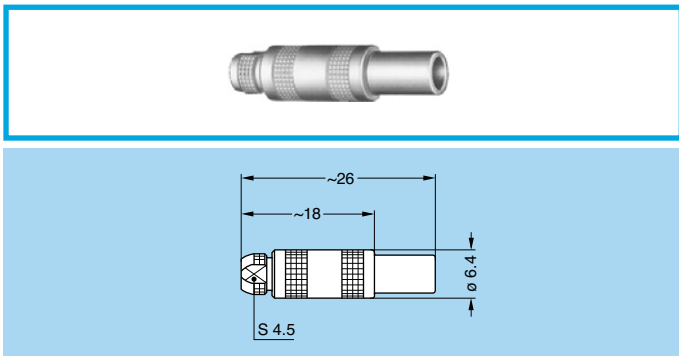

FFF Straight plug, non-latching, with cable collet

Part number	Cable group	Cond. Ø max	Dielectric Ø maxi	Sheath Ø	
				mini	maxi
FFF.00.250.NTAC22	1	0.55	1.95	1.7	2.1
FFF.00.250.NTAC27	2-3-4	0.55	1.95	2.3	2.7
FFF.00.250.NTAC31	8	0.55	1.95	2.8	3.0

M1 Cable assembly, solder contact (page 39)

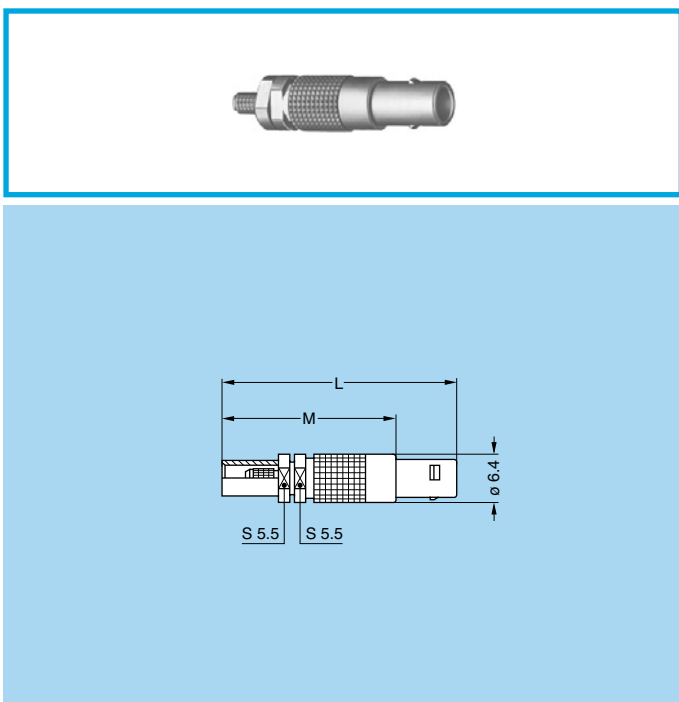

FFS Straight plug for cable crimping

Part number	Dim		Cable group	Cond. Ø maxi	Dielec. Ø maxi	Sheath Ø maxi
	L	M				
FFS.00.250.CTAE24	31	23	1	0.4	0.95	2.35
FFS.00.250.CTAE31	31	23	3-4	0.55	1.65	3.0
FFS.00.250.CTAE52	34	26	6	0.97	3.05	5.2

M5 Cable assembly, solder contact (page 41)

Part number	Dim		Cable group	Cond. Ø		Dielec. Ø maxi	Sheath Ø maxi
	L	M		mini	maxi		
FFS.00.250.CTCE24	31	23	1	0.28	0.4	0.95	2.35
FFS.00.250.CTCE25	31	23	1	0.28	0.4	1.15	2.35
FFS.00.250.CTCE30	31	23	2	0.28	0.4	1.65	3.0
FFS.00.250.CTCE31	31	23	3-4	0.46	0.55	1.65	3.0
FFS.00.250.CTCE35	31	23	8	0.46	0.55	1.65	3.35
FFS.00.250.CTCE44	31	23	5	0.28	0.4	2.65	4.35
FFS.00.250.CTCE52	34	26	6	0.90	0.97	3.05	5.2
FFS.00.250.CTCE56	34	26	7	0.90	0.97	3.05	5.45

M4 Cable assembly, crimp contact (page 40)

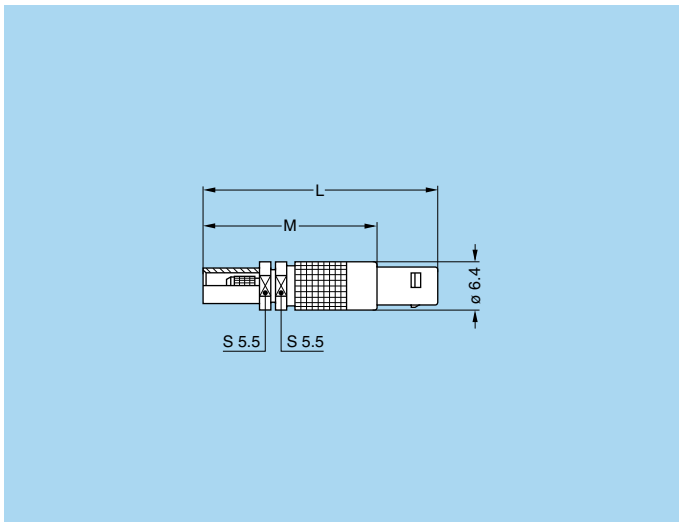

FFV Straight plug for cable crimping with improved screen efficiency ¹⁾

Part number	Dim		Cable group	Cond. Ø maxi	Dielec. Ø maxi	Sheath Ø maxi
	L	M				
FFV.00.250.NTAE24	31	23	1	0.4	0.95	2.35
FFV.00.250.NTAE31	31	23	3-4	0.55	1.65	3.0
FFV.00.250.NTAE52	34	26	6	0.97	3.05	5.2

M5 Cable assembly, solder contact (page 41)

Part number	Dim		Cable group	Cond. Ø		Dielec. Ø maxi	Sheath Ø maxi
	L	M		mini	maxi		
FFV.00.250.NTCE24	31	23	1	0.28	0.4	0.95	2.35
FFV.00.250.NTCE30	31	23	2	0.28	0.4	1.65	3.0
FFV.00.250.NTCE31	31	23	3-4	0.46	0.55	1.65	3.0
FFV.00.250.NTCE35	31	23	8	0.46	0.55	1.65	3.35
FFV.00.250.NTCE44	31	23	5	0.28	0.4	2.65	4.35
FFV.00.250.NTCE52	34	26	6	0.90	0.97	3.05	5.2
FFV.00.250.NTCE56	34	26	7	0.90	0.97	3.05	5.45

M4 Cable assembly, crimp contact (page 40)

Note: ¹⁾ Screen efficiency >100dB at 1 GHz, see page 8.

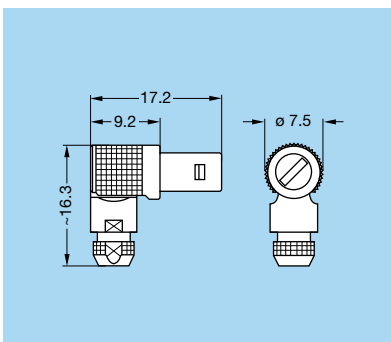
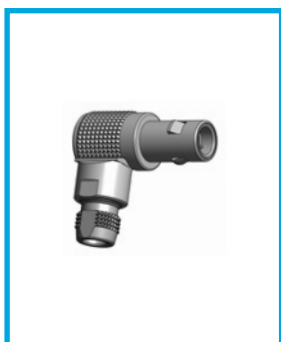

FLC Elbow plug (90°) with cable collet

Part number	Cable group	Cond. Ø max	Dielectric Ø maxi	Sheath Ø	
				mini	maxi
FLC.00.250.CTAC22	1	0.35	1.55	1.7	2.1
FLC.00.250.CTAC27	-	0.35	1.75	2.3	2.7
FLC.00.250.CTAC31	-	0.35	1.75	2.8	3.0

M6 Cable assembly, solder contact (page 42)

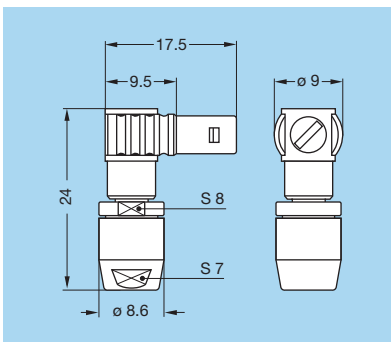

FLA Elbow plug (90°) with oversized cable collet

Part number	Cable group	Cond. Ø max	Dielectric Ø maxi	Sheath Ø	
				mini	maxi
FLA.00.250.CTAD42	8	0.97	1.75	3.1	4.0
FLA.00.250.NTAD52	6	0.97	1.75	4.1	5.0
FLA.00.250.NTAD56	7	0.97	1.75	5.1	5.5

M6 Cable assembly, solder contact (page 42)

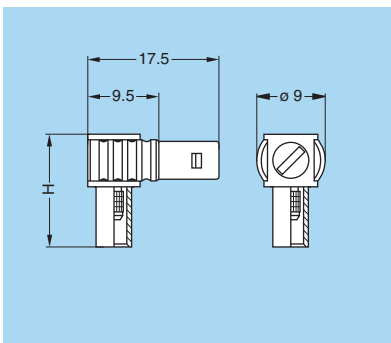

FLS Elbow plug (90°) for cable crimping

Part number	H (mm)	Cable group	Cond. Ø maxi	Dielectric Ø maxi	Sheath Ø maxi
FLS.00.250.NTAE31	15	-	0.35	1.65	3.0
FLS.00.250.NTAE35	15	-	0.35	1.65	3.35
FLS.00.250.NTAE52	18	6	0.97	3.05	5.2
FLS.00.250.NTAE56	18	7	0.97	3.05	5.45

M7 Cable assembly, solder contact (page 42)

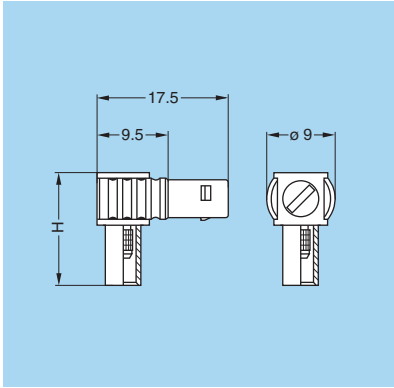

FLV Elbow plug (90°) for cable crimping with improved screen efficiency *

Part number	H (mm)	Cable group	Cond. Ø maxi	Dielectric Ø maxi	Sheath Ø maxi
FLV.00.250.NTAE31	15	3-4	0.35	1.65	3.0
FLV.00.250.NTAE35	15	8	0.35	1.65	3.35
FLV.00.250.NTAE52	18	6	0.97	3.05	5.2
FLV.00.250.NTAE56	18	7	0.97	3.05	5.45

M7 Cable assembly, solder contact (page 42)

* Screen efficiency >100dB at 1 GHz, see page 8.

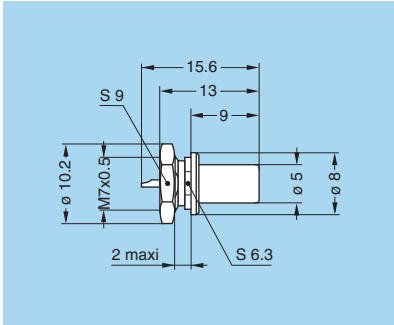
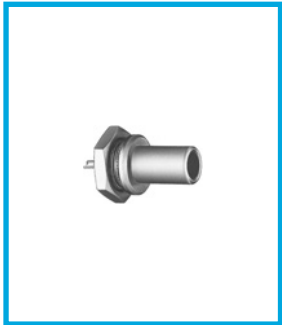

FAA Straight plug, non-latching, nut fixing

Part number	Weight (g)
FAA.00.250.NTA	2.5

P5 Panel cut-out (page 38)

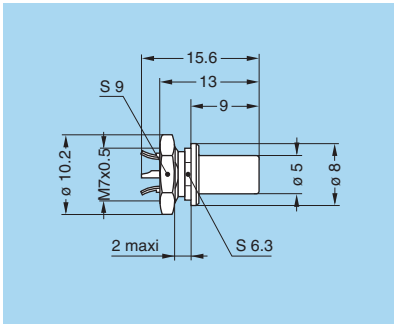
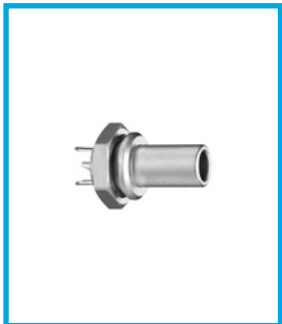

FAN Straight plug, non-latching, nut fixing with earthing tags

Part number	Weight (g)
FAN.00.250.CLA	2.5

P5 Panel cut-out (page 38)

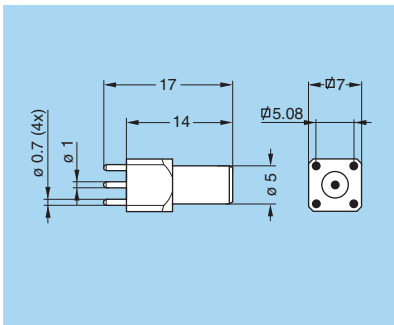
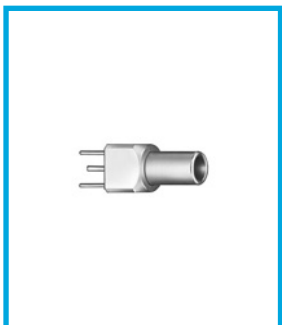

FPA Straight plug, non-latching, for printed circuit

Part number	Weight (g)
FPA.00.250.NTD	2.5

P11 PCB drilling pattern (page 38)

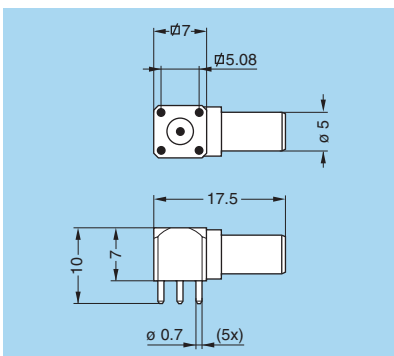
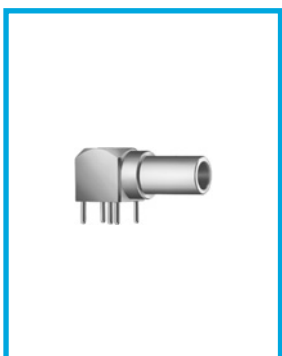

FPL Elbow plug (90°), non-latching for printed circuit

Part number	Weight (g)
FPL.00.250.NTD	2.5

P10 PCB drilling pattern (page 38)

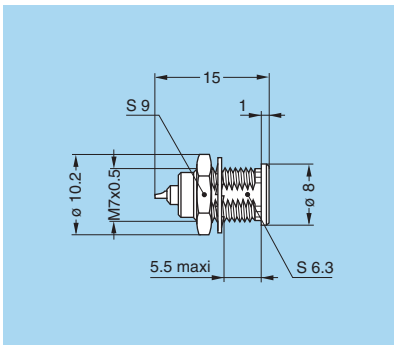

ERA Fixed socket, nut fixing

Part number	Weight (g)
ERA.00.250.NTL	2.5

P5 Panel cut-out (page 38)

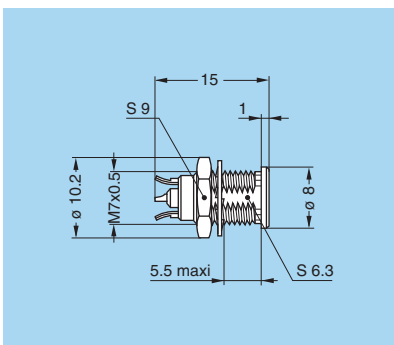

ERN Fixed socket, nut fixing, with earthing tags

Part number	Weight (g)
ERN.00.250.NTL	2.5

P5 Panel cut-out (page 38)

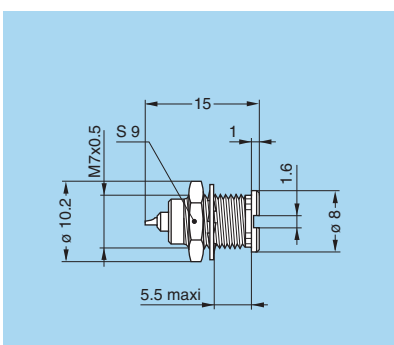

ERC Fixed socket, with thread, with slots in flange

Part number	Weight (g)
ERC.00.250.NTL	2.6

P1 Panel cut-out (page 38)

P3 Panel cut-out for use without hexagonal nut (page 38)

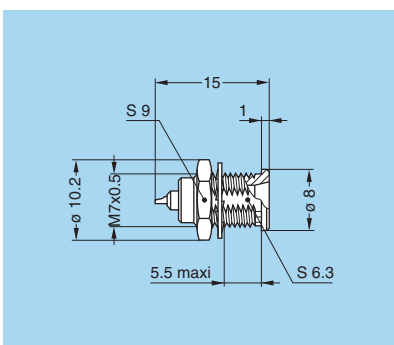

ERE Fixed socket, nut fixing, with conical lead-in

Part number	Weight (g)
ERE.00.250.NTL	2.8

P5 Panel cut-out (page 38)

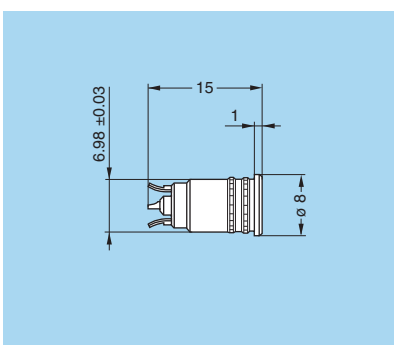

ERT Straight socket without thread, force or adhesive fit, with earthing tags

Part number	Weight (g)
ERT.00.250.NTL	2.1

P4 Panel cut-out (page 38)

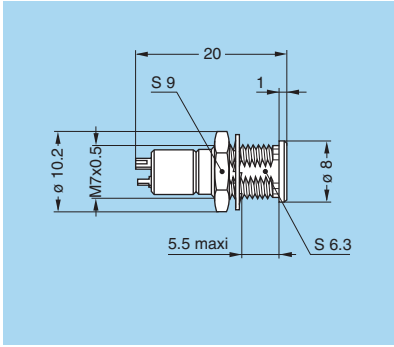
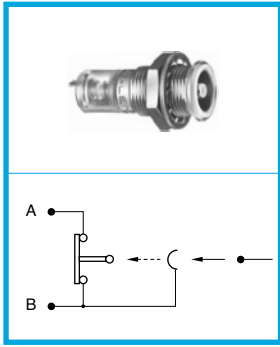

ERM Fixed socket, nut fixing, with microswitch

Part number	Weight (g)
ERM.00.250.NTL	3.0

P5 Panel cut-out (page 38)

Technical characteristics on request

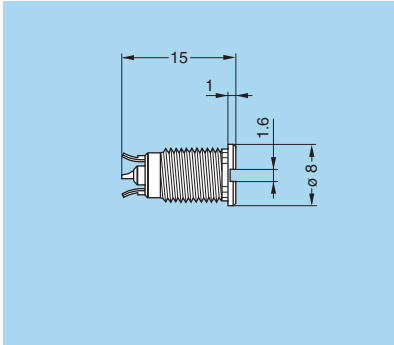

ERX Fixed socket, with thread, with slots in flange, with earthing tags

Part number	Weight (g)
ERX.00.250.NTL	2.0

P3 Panel cut-out (page 38)

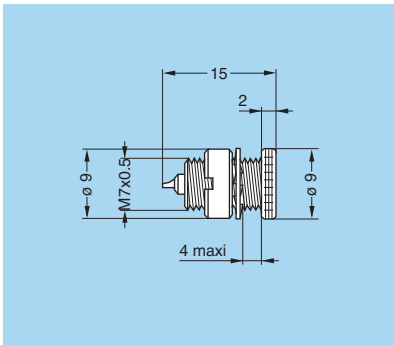

ECP Fixed socket with two nuts

Part number	Weight (g)
ECP.00.250.NTL	3.3

P1 Panel cut-out (page 38)

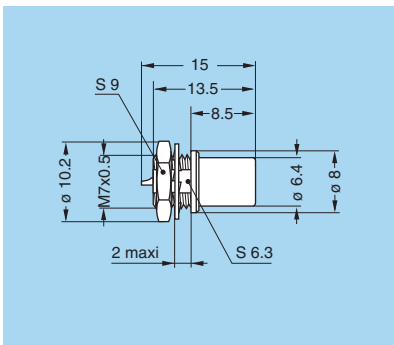

EHP Fixed socket, nut fixing, protruding shell

Part number	Weight (g)
EHP.00.250.NTL	2.8

P5 Panel cut-out (page 38)

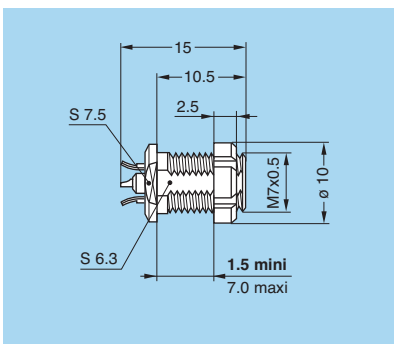

ELF Fixed socket, with slotted nut, long threaded shell, with earthing tags (back panel mounting)

Part number	Weight (g)
ELF.00.250.NTL	3.1

P5 Panel cut-out (page 38)

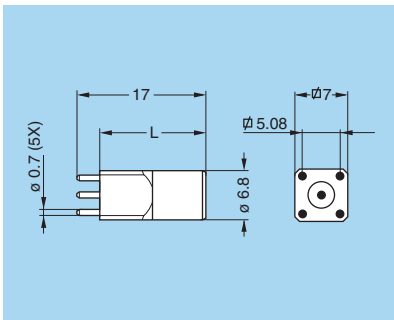

EPA-EPB Straight socket for printed circuit

Part number	L (mm)	Weight (g)
EPA.00.250.NTN	14	3.4
EPB.00.250.NTN	12	3.3

P10 PCB drilling pattern (page 38)

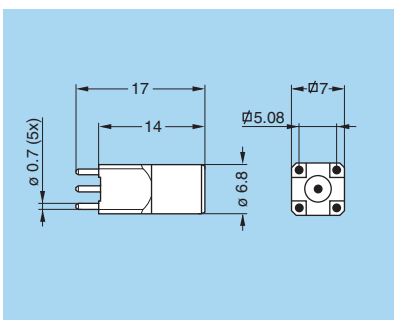
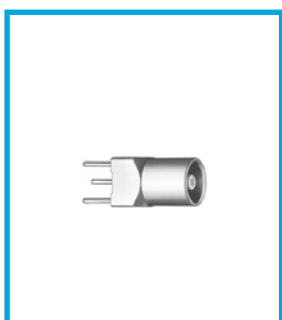

EPC Straight socket for printed circuit with clearance under the body

Part number	Weight (g)
EPC.00.250.NTN	3.3

P10 PCB drilling pattern (page 38)

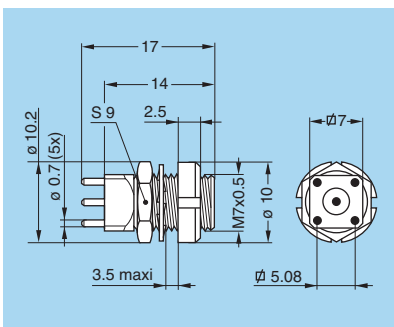

EPE Fixed socket with two nuts, for printed circuit

Part number	Weight (g)
EPE.00.250.NTN	4.3

P1 Panel cut-out (page 38)

P12 PCB drilling pattern (page 38)

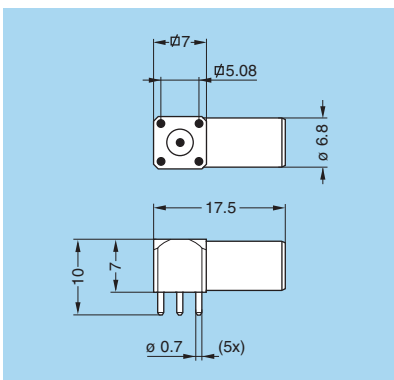
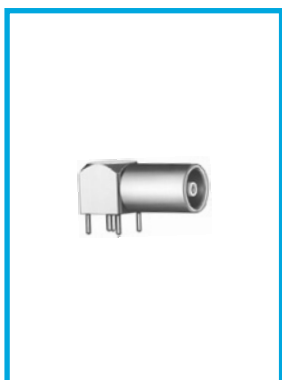

EPL Elbow socket (90°) for printed circuit

Part number	H (mm)	Weight (g)
EPL.00.250.NTN	10	4.3

P10 PCB drilling pattern (page 38)

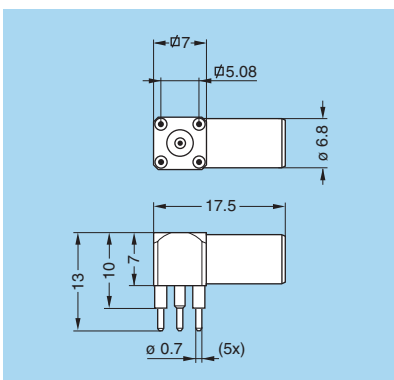

EPM Elbow socket (90°) for printed circuit, elevated solder tail

Part number	H (mm)	Weight (g)
EPM.00.250.NTN	13	4.6

P10 PCB drilling pattern (page 38)

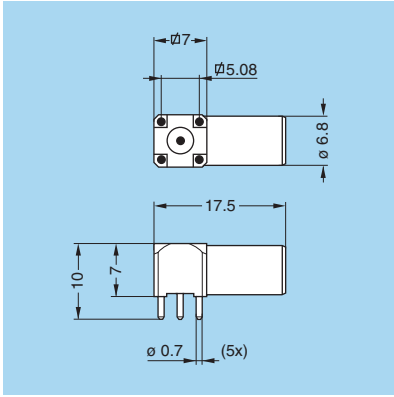

EPK Elbow socket (90°) for printed circuit with clearance under the body

Part number	Weight (g)
EPK.00.250.NTN	4.2

P10 PCB drilling pattern (page 38)

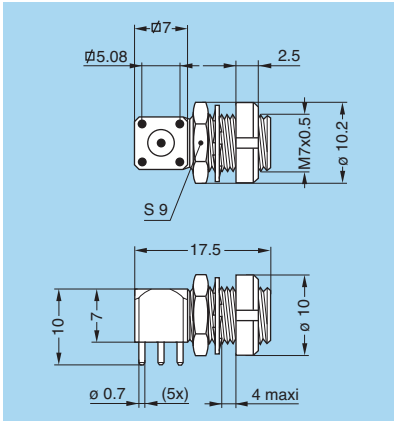
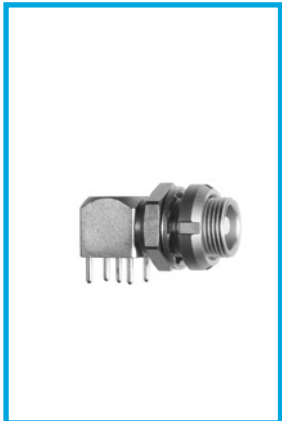

EPS Elbow socket (90°) with two nuts, for printed circuit

Part number	Weight (g)
EPS.00.250.NTN	5.4

P1 Panel cut-out (page 38)

P12 PCB drilling pattern (page 38)

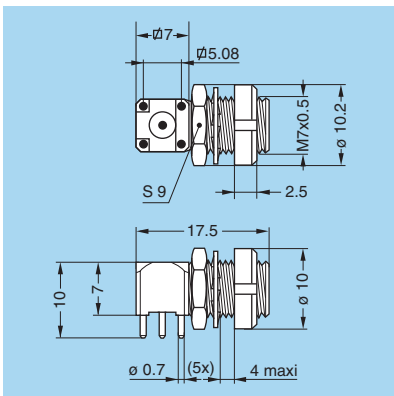

EPR Elbow socket (90°) with two nuts for printed circuit, with clearance under the body (back panel mounting)

Part number	Weight (g)
EPR.00.250.NTN	5.4

P1 Panel cut-out (page 38)

P12 PCB drilling pattern (page 38)

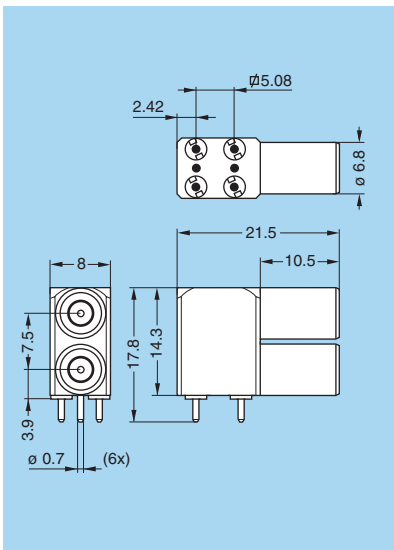
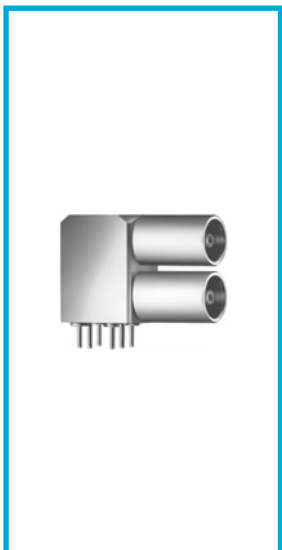

EPY Elbow socket (90°) for printed circuit, with two vertical sockets

Part number	Weight (g)
EPY.00.250.NTN	12.8

P13 PCB drilling pattern (page 38)

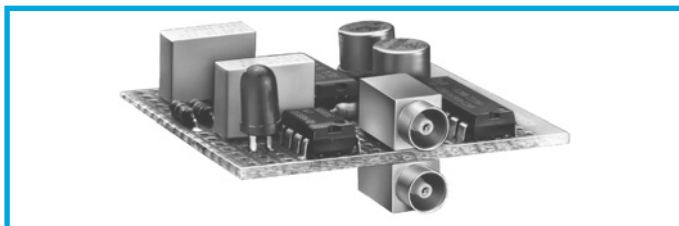

EPN Straight socket for press mounting in pair on printed circuit

Part number	Weight (g)
EPN.00.250.NTN	3.6

P9 PCB drilling pattern (page 38)

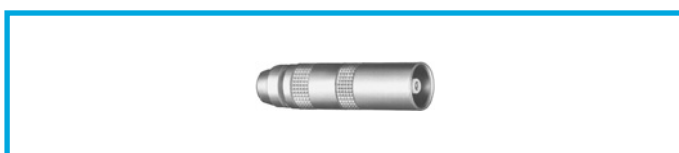
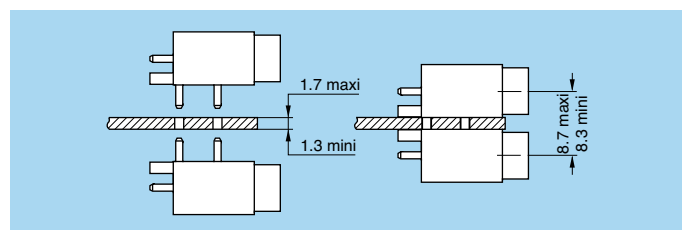
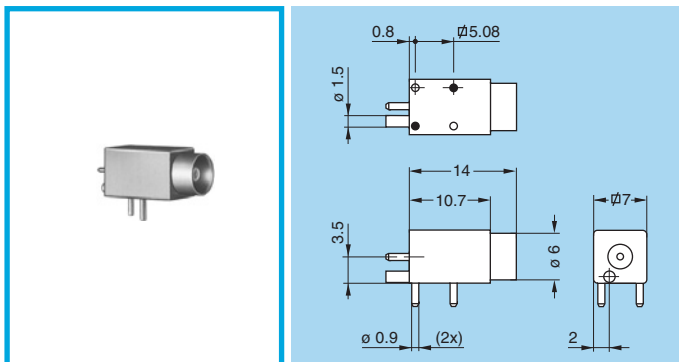

PCA Free socket with cable collet

Part number	Cable group	Cond. Ø max	Dielectric Ø maxi	Sheath Ø	
				mini	maxi
PCA.00.250.NTLC15	9	0.55	1.45	1.1	1.4
PCA.00.250.NTLC22	1	0.55	1.95	1.7	2.1
PCA.00.250.NTLC27	2-3-4	0.55	1.95	2.3	2.7
PCA.00.250.NTLC31	8	0.55	1.95	2.8	3.0

M1 Cable assembly (page 39)

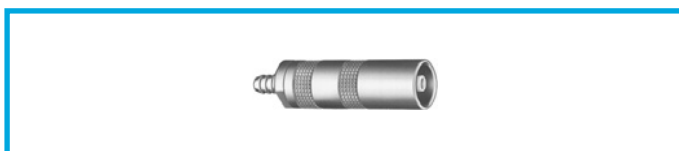
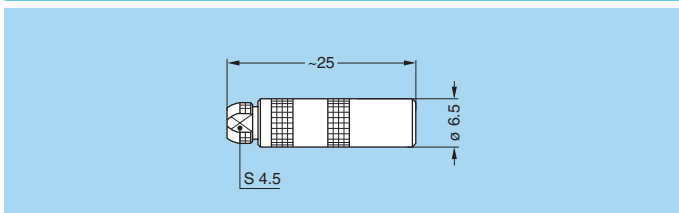

PCS Free socket for cable crimping

Part number	Dim L	Cable group	Cond. Ø		Dielec. Ø maxi	Sheath Ø maxi
			mini	maxi		
PCS.00.250.NTME24	30	1	0.28	0.4	0.95	2.35
PCS.00.250.NTME30	30	2	0.28	0.4	1.65	3.0
PCS.00.250.NTME31	30	3-4	0.46	0.55	1.65	3.0
PCS.00.250.NTME44	30	5	0.28	0.4	2.65	4.35
PCS.00.250.NTME52	33	6	0.90	0.97	3.05	5.2

M4 Cable assembly, crimp contact (page 40)

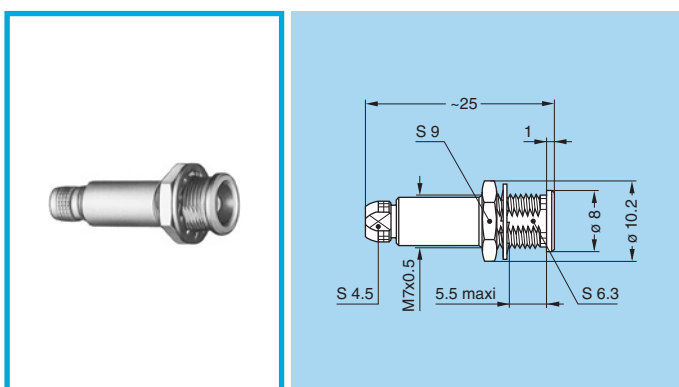
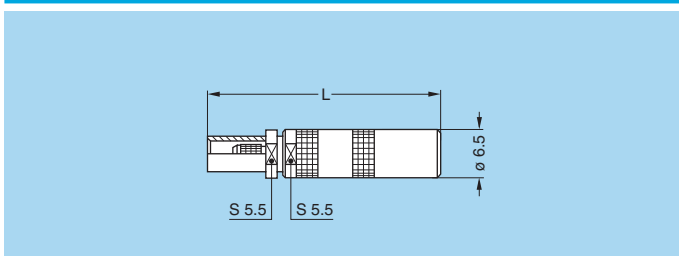

PSA Fixed socket, nut fixing, with cable collet

Part number	Cable group	Cond. Ø max	Dielectric Ø maxi	Sheath Ø	
				mini	maxi
PSA.00.250.NTLC22	1	0.55	1.95	1.7	2.1
PSA.00.250.NTLC27	2-3-4	0.55	1.95	2.3	2.7
PSA.00.250.NTLC31	8	0.55	1.95	2.8	3.0

M1 Cable assembly (page 39)

P5 Panel cut-out (page 38)

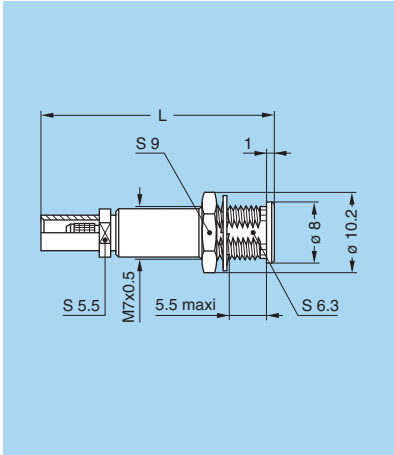

PSS Fixed socket, nut fixing, for cable crimping

Part number	Dim L	Cable group	Cond. Ø		Dielec. Ø maxi	Sheath Ø maxi
			mini	maxi		
PSS.00.250.NTME24	30	1	0.28	0.4	0.95	2.35
PSS.00.250.NTME30	30	2	0.28	0.4	1.65	3.0
PSS.00.250.NTME31	30	3-4	0.46	0.55	1.65	3.0
PSS.00.250.NTME35	30	8	0.46	0.55	1.65	3.35
PSS.00.250.NTME52	33	6	0.90	0.97	3.05	5.2

M4 Cable assembly, crimp contact (page 40)

P5 Panel cut-out (page 38)

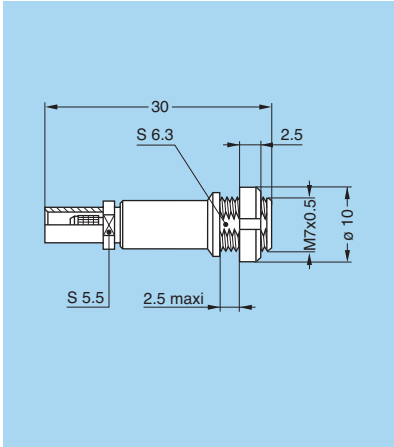

PES Fixed socket, nut fixing, for cable crimping (back panel mounting)

Part number	Cable group	Cond. Ø		Dielectric Ø maxi	Sheath Ø maxi
		mini	maxi		
PES.00.250.NTME24	1	0.28	0.4	0.95	2.35
PES.00.250.NTME30	2	0.28	0.4	1.65	3.0
PES.00.250.NTME31	3-4	0.46	0.55	1.65	3.0
PES.00.250.NTME35	8	0.46	0.55	1.65	3.35

M4 Cable assembly, crimp contact (page 40)

P5 Panel cut-out (page 38)

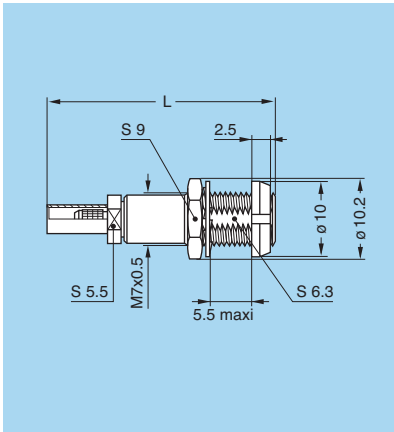

PFS Fixed socket, with two nuts, for cable crimping (back panel mounting)

Part number	Dim L	Cable group	Cond. Ø		Dielec. Ø maxi	Sheath Ø maxi
			mini	maxi		
PFS.00.250.NTME24	30	1	0.28	0.4	0.95	2.35
PFS.00.250.NTME31	30	3-4	0.46	0.55	1.65	3.0
PFS.00.250.NTME52	33	6	0.90	0.95	3.05	5.2

P5 Panel cut-out (page 38)

Cable assembly, please contact customer services

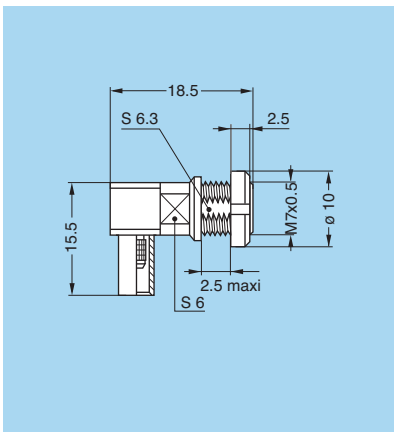

PLK Fixed elbow socket (90°), for cable crimping (back panel mounting)

Part number	Cable group	Cond. Ø		Dielectric Ø maxi	Sheath Ø maxi
		mini	maxi		
PLK.00.250.NTLE31	3-4	0.46	0.55	1.65	3.0
PLK.00.250.NTLE35	8	0.46	0.55	1.65	3.35

P5 Panel cut-out (page 38)

Cable assembly, please contact customer services

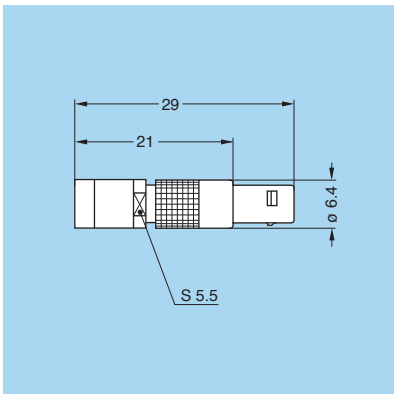

FRT Straight plug with resistor

Part number	Resistor	Weight (g)	Note
FRT.00.250.NTA00	shorted	4.4	●
FRT.00.250.NTA50	50 Ω 0.6W	4.4	●
FRT.00.250.NTA100	100 Ω 0.4W	4.4	○

Note: ● Standard, first choice alternative
○ Non standard, on request only

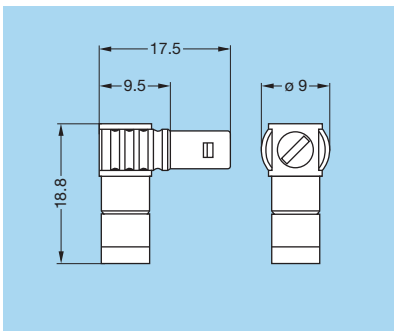

FLR Elbow plug (90°) with resistor

Part number	Resistor	Weight (g)
FLR.00.250.NTA50	50 Ω 0.6W	5.6

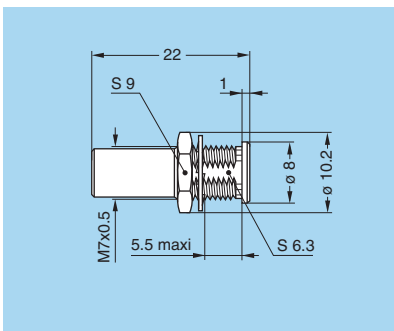

RAD Fixed coupler, nut fixing

Part number	Weight (g)
RAD.00.250.NTM	3.8

P5 Panel cut-out (page 38)

Note: the first contact type mentioned (page 7) is always the contact at the flange end.

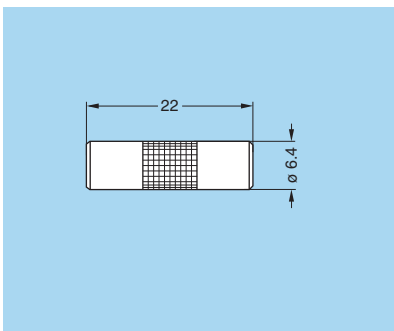
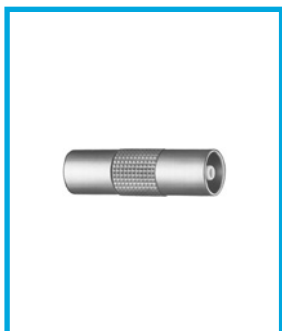

RMA Free coupler

Part number	Weight (g)
RMA.00.250.NTM	2.7

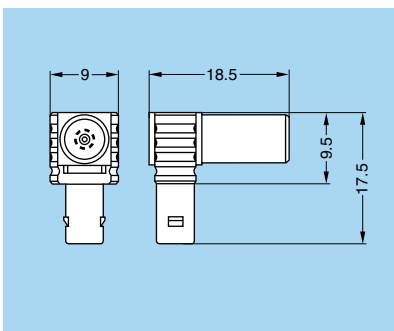

FTR Elbow plug (90°) with socket

Part number	Weight (g)
FTR.00.250.NTA	5.4

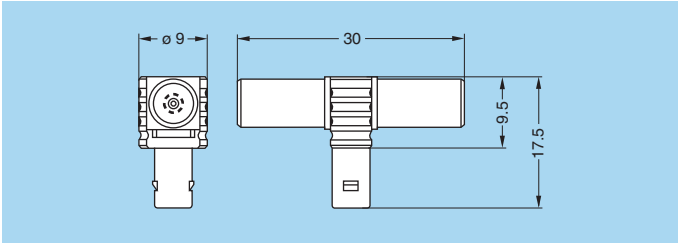
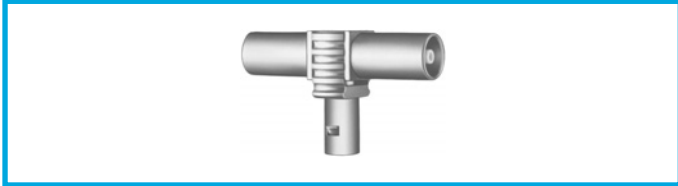

FTA T-plug with two sockets in line

Part number	Weight (g)
FTA.00.250.NTF	7.8

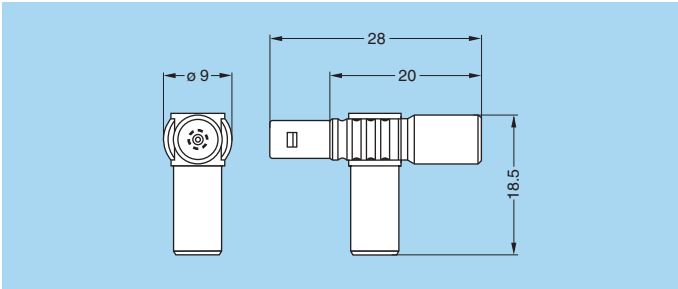
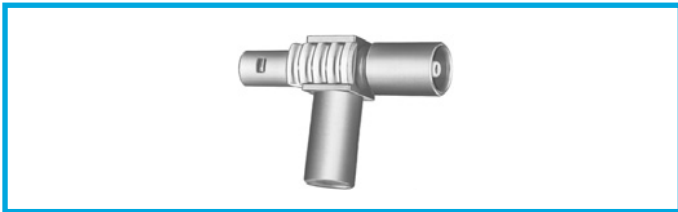

FTL T-plug with two sockets (90°)

Part number	Weight (g)
FTL.00.250.NTF	7.1

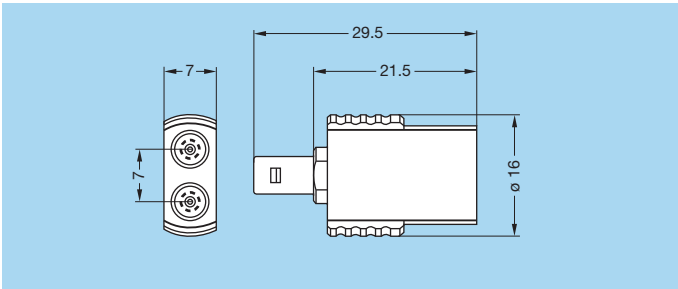

FTY Straight plug with two parallel sockets

Part number	Weight (g)
FTY.00.250.NTF	12.5

Plastic housing models

This plastic housing provides the ideal solution when the isolation of the connector is critical (non metallic). The FFA and ERN models in PEEK allow weight saving and can provide ease of use in applications such as medical electronic instrumentation.

Technical Characteristics

Mechanical and climatical

Characteristics	Value	Standard	Test
Contact retention force	> 18 N	IEC 60512-8	15a
Cable pull off force	> 100 N	IEC 60512-9	17a
Connector pull off force	> 90 N		
Endurance	> 5000 cycles	IEC 60512-5	9a
Operating temperature	- 50°C + 250°C		

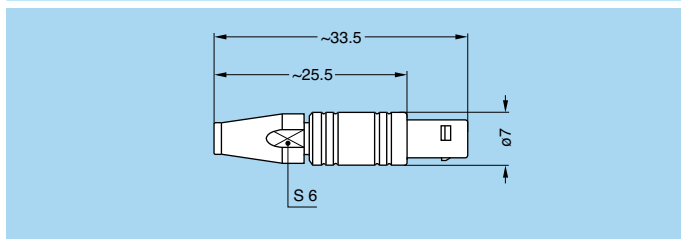

FFA Straight plug with cable collet, PEEK outer shell

Part number	Cable group	Cond. Ø max	Dielectric Ø maxi	Sheath Ø	
				mini	maxi
FFA.00.250.GTAC15	9	0.55	1.45	1.1	1.4
FFA.00.250.GTAC17	-	0.55	1.45	1.3	1.7
FFA.00.250.GTAC22	1	0.55	1.95	1.7	2.1
FFA.00.250.GTAC27	2-3-4	0.55	1.95	2.3	2.7
FFA.00.250.GTAC31	8	0.55	1.95	2.8	3.0

M1 Cable assembly (page 39)

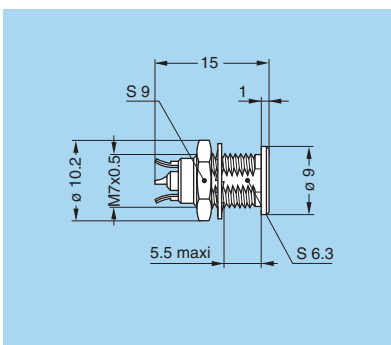

ERN Fixed socket, nut fixing, with earthing tags, PEEK outer shell

Part number	Weight (g)
ERN.00.250.GTL	1.4

P5 Panel cut-out (page 38)

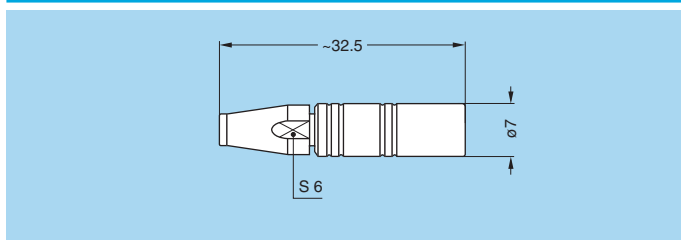

PCA Free socket with cable collet, PEEK outer shell

Part number	Cable group	Cond. Ø max	Dielectric Ø maxi	Sheath Ø	
				mini	maxi
PCA.00.250.GTLC15	9	0.55	1.45	1.1	1.4
PCA.00.250.GTLC17	-	0.55	1.45	1.3	1.7
PCA.00.250.GTLC22	1	0.55	1.95	1.7	2.1
PCA.00.250.GTLC27	2-3-4	0.55	1.95	2.3	2.7
PCA.00.250.GTLC31	8	0.55	1.95	2.8	3.0

M1 Cable assembly (page 39)

Watertight or vacuumtight models

A range of sealed sockets and couplers allows the device on which they are fitted to reach a protection index of IP68 as per IEC 60529 (unmated). They are fully compatible with plugs of the same series and are widely used for portable radios, military, laboratory equipment, aviation, etc.

These models are identified by a letter «P» at the end of the reference for watertight model and by a «PV» for vacuumtight models. Epoxy resin or o-rings are used to seal these models.

Mechanical and climatical

Characteristics	Value	Standard
Endurance	> 5000 cycles	IEC 60512-5 test 9a
Humidity	up to 95% at 60° C	
Temperature range	- 20° C/+100° C	
Salt spray corrosion test	> 144h	IEC 60512-6 test 11f
Climatical category	20/80/21	IEC 60068-1
Leakage rate (He) ¹⁾	< 10 ⁻⁷ mbar.l.s ⁻¹	IEC 60512-7 test 14b
Maximum operating pressure ²⁾	60 bars	IEC 60512-7 test 14d

Note:

1) only for vacuumtight models.
2) this value corresponds to the maximum allowed pressure difference for the assembled socket.

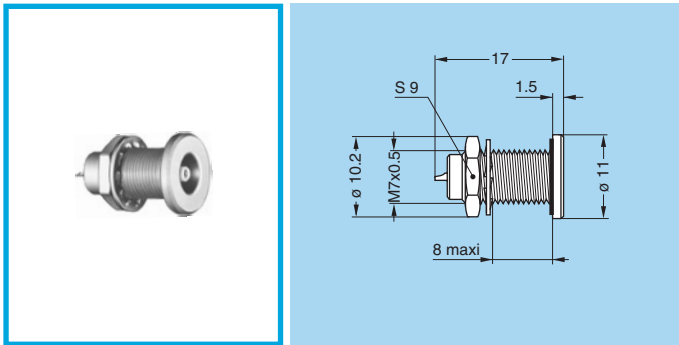

HGP Fixed socket, nut fixing, watertight or vacuumtight

Part number	Weight (g)
HGP.00.250.NTLP	4.2
HGP.00.250.NTLPV	4.2

P1 Panel cut-out (page 38)

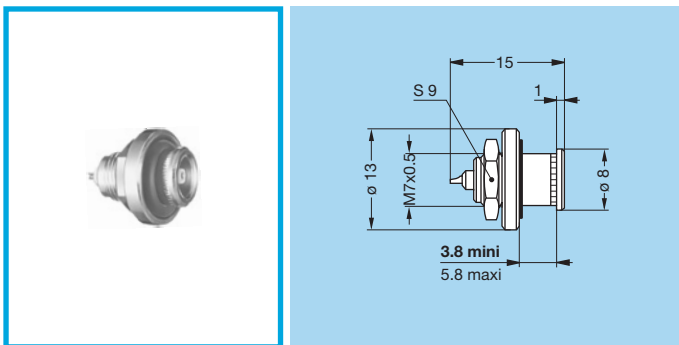

HGW Fixed socket, nut fixing, watertight with rear sealing ring

Part number	Weight (g)
HGW.00.250.NTLP	4.2

P1 Panel cut-out (page 38)

Note: Non standard, on request only

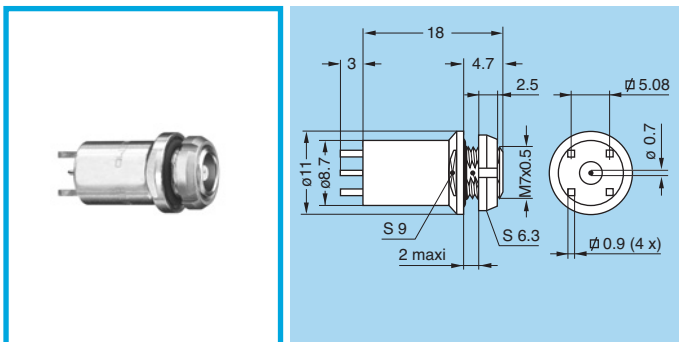

HEP Fixed socket, nut fixing, watertight for printed circuit (back panel mounting)

Part number	Weight (g)
HEP.00.250.NTNP	7.4

P5 Panel cut-out (page 38)

P15 PCB drilling pattern (page 38)

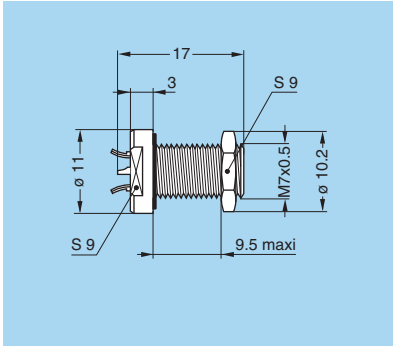

EWF Fixed socket, nut fixing, watertight or vacuumtight (back panel mounting)

Part number	Weight (g)
EWF.00.250.NTLP	4.2
EWF.00.250.NTLPV	4.2

P1 Panel cut-out (page 38)

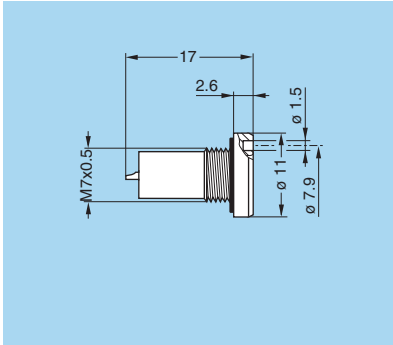

EWV Fixed socket, watertight or vacuumtight

Part number	Weight (g)
EWV.00.250.NTLP	3.7
EWV.00.250.NTLPV	3.7

P2 Panel cut-out (page 38)

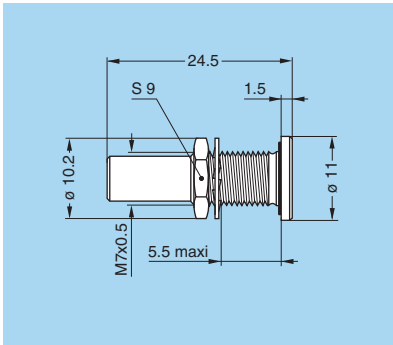

SWH Fixed coupler, nut fixing, vacuumtight

Part number	Weight (g)
SWH.00.250.NTMV	5.2

P1 Panel cut-out (page 38)

Note: this model is sealed with o-rings (no epoxy).

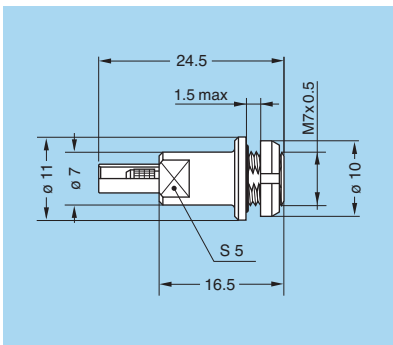

VPS Fixed socket, short shell, vacuumtight with cable crimping (back panel mounting)

Part number	Cable group	Cond. Ø		Dielectric Ø maxi	Sheath Ø maxi
		mini	maxi		
VPS.00.250.CTLE31	3-4	0.46	0.55	1.65	3.0

P1 Panel cut-out (page 38)

Cable assembly, please contact customer service

Metal housing models with mechanical keying

The straight plug and receptacle models FSG, XBG, XRG, XSG, ESG, EXG and PSG are available with a key to avoid cross mating of similar connectors. These models are not included in the NIM-CAMAC standard.

The standard "G" key consists of one mechanical alignment key.

Front view of the standard "G" key

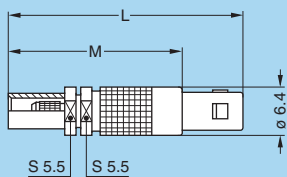

FSG Straight plug with key (G), with cable crimping

Part number	Dim		Cable group	Cond. Ø maxi	Dielec. Ø maxi	Sheath Ø maxi
	L	M				
FSG.00.250.NTAE24	31	23	1	0.4	0.95	2.35
FSG.00.250.NTAE31	31	23	3-4	0.55	1.65	3.0
FSG.00.250.NTAE52	34	26	6	0.97	3.05	5.2

M5 Cable assembly, solder contact (page 41)

Part number	Dim		Cable group	Cond. Ø		Dielec. Ø maxi	Sheath Ø maxi
	L	M		mini	maxi		
FSG.00.250.NTCE24	31	23	1	0.28	0.4	0.95	2.35
FSG.00.250.NTCE31	31	23	3-4	0.46	0.55	1.65	3.0
FSG.00.250.NTCE52	34	26	6	0.90	0.97	3.05	5.2

M4 Cable assembly, crimp contact (page 40)

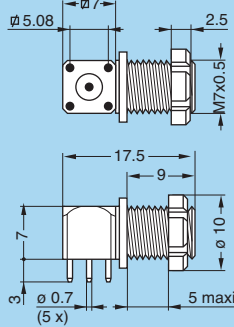
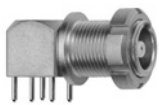

XBG Elbow socket (90°) with slotted nut, for printed circuit with key (G)

Part number	Weight (g)
XBG.00.250.NTN	5.1

P1 Panel cut-out (page 38)

P12 PCB drilling pattern (page 38)

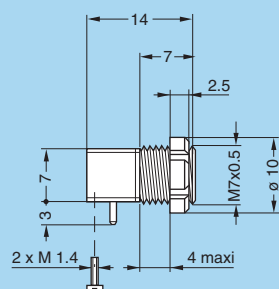

XRG Elbow socket (90°), with key (G), short shell and slotted nut, for printed circuit, screw fixing (back panel mounting)

Part number	Weight (g)
XRG.00.250.NTN	3.8

P1 Panel cut-out (page 38)

P14 PCB drilling pattern (page 38)

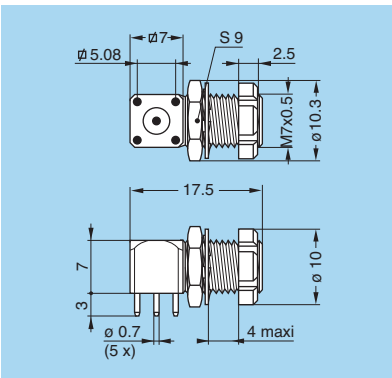

XSG Elbow socket (90°) with slotted with key (G), and hex nuts for printed circuit

Part number	Weight (g)
XSG.00.250.NTN	5.4

- P1** Panel cut-out (page 38)
- P12** PCB drilling pattern (page 38)

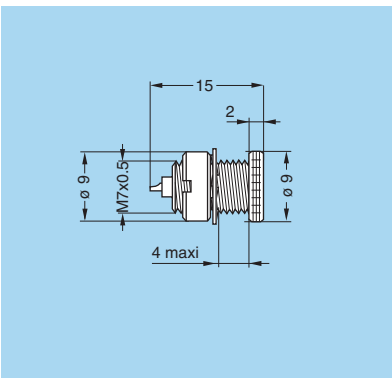

ESG Fixed socket with two round nuts, threaded shell, with key (G) (back panel mounting)

Part number	Weight (g)
ESG.00.250.NLL	3.1

- P1** Panel cut-out (page 38)

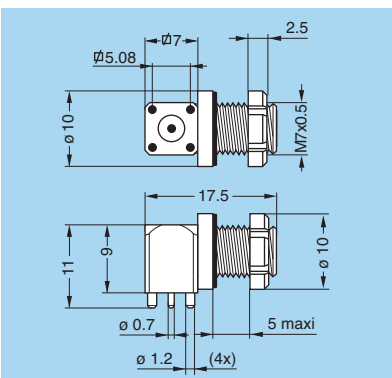

EXG Elbow socket (90°) with slotted nut for printed circuit, with key (G), with o-ring on flange (back panel mounting). Special shell design.

Part number	Weight (g)
EXG.00.250.NTNY	6.3

- P1** Panel cut-out (page 38)
- P15** PCB drilling pattern (page 38)

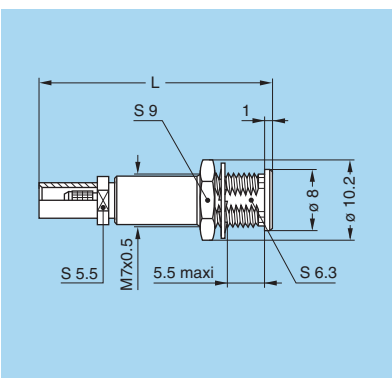

PSG Fixed socket, nut fixing, with key (G) with cable crimping

Part number	Dim L	Cable group	Cond. Ø		Dielec. Ø maxi	Sheath Ø maxi
			mini	maxi		
PSG.00.250.NTME24	30	1	0.28	0.4	0.95	2.35
PSG.00.250.NTME31	30	3-4	0.46	0.55	1.65	3.0
PSG.00.250.NTME52	33	6	0.90	0.97	3.05	5.2

- M4** Cable assembly, crimp contact (page 40)
- P5** Panel cut-out (page 38)

Threaded-coupling models

The straight plug and receptacle models FVS, EPE and EPS are available with threaded coupling. On sockets, 3.2 mm minimum length of free threading must be available to ensure screw mating. These models are not included in the NIM-CAMAC standard.



FVS Straight plug for cable crimping

Part number	Dim		Cable group	Cond. Ø maxi	Dielec. Ø maxi	Sheath Ø maxi
	L	M				
FVS.00.250.NTAE24	31	23	1	0.4	0.95	2.35
FVS.00.250.NTAE31	31	23	3-4	0.55	1.65	3.0
FVS.00.250.NTAE52	34	26	6	0.97	3.05	5.2

M5 Cable assembly, solder contact (page 41)

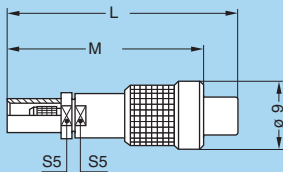

Part number	Dim		Cable group	Cond. Ø		Dielec. Ø maxi	Sheath Ø maxi
	L	M		mini	maxi		
FVS.00.250.NTCE24	31	23	1	0.28	0.4	0.95	2.35
FVS.00.250.NTCE25	31	23	1	0.28	0.4	1.15	2.35
FVS.00.250.NTCE30	31	23	2	0.28	0.4	1.65	3.0
FVS.00.250.NTCE31	31	23	3-4	0.46	0.55	1.65	3.0
FVS.00.250.NTCE35	31	23	8	0.46	0.55	1.65	3.35
FVS.00.250.NTCE44	31	23	5	0.28	0.4	2.65	4.35
FVS.00.250.NTCE52	34	26	6	0.90	0.97	3.05	5.2
FVS.00.250.NTCE56	34	26	7	0.90	0.97	3.05	5.45

M4 Cable assembly, crimp contact (page 40)

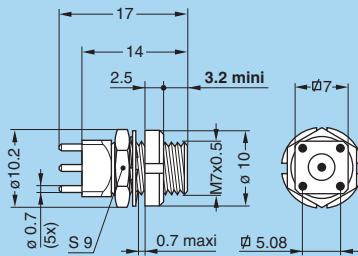

EPE Straight socket with two nuts, for printed circuit

Part number	Weight (g)
EPE.00.250.NTN	4.3

P1 Panel cut-out (page 38)

P12 PCB drilling pattern (page 38)

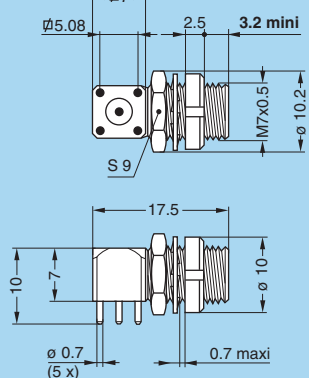

EPS Elbow socket (90°) with two nuts, for printed circuit

Part number	Weight (g)
EPS.00.250.NTN	5.4

P1 Panel cut-out (page 38)

P12 PCB drilling pattern (page 38)



Adaptors

ABF Adaptor from LEMO plug to BNC socket

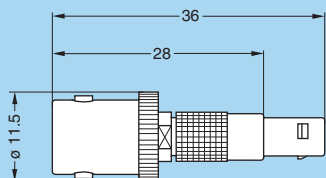
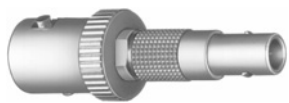

Part number	Weight (g)
ABF.00.250.NTA	8.3

APF Adaptor from LEMO plug to CINCH socket

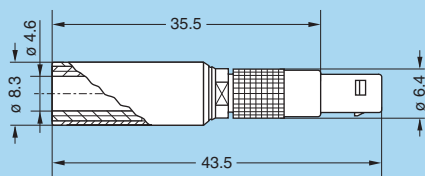
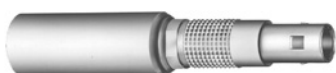

Part number	Colour of the ring	Weight (g)
APF.00.250.DTAB	white	7
APF.00.250.DTAR	red	7

ABA Adaptor from LEMO socket to BNC plug

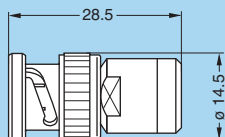

Part number	Weight (g)
ABA.00.250.NTL	18.7

ABC Adaptor from LEMO socket to BNC socket

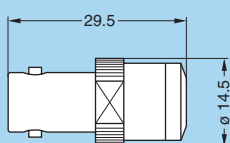

Part number	Weight (g)
ABC.00.250.NTM	17

ABD Adaptor from LEMO socket to BNC fixed socket

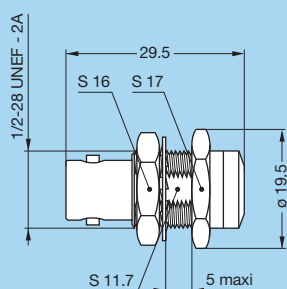
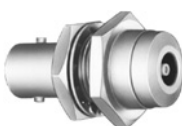

Part number	Weight (g)
ABD.00.250.NTM	21.4

P7 Panel cut-out (page 38)



ABB Adaptor from LEMO fixed socket to BNC socket

Part number	Weight (g)
ABB.00.250.NTM	9.4

P6 Panel cut-out (page 38)

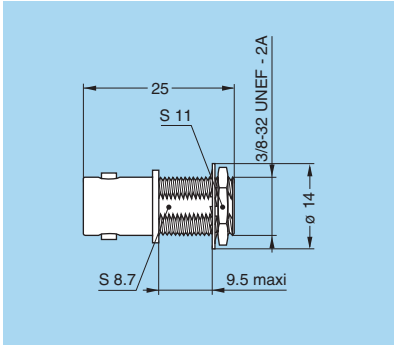
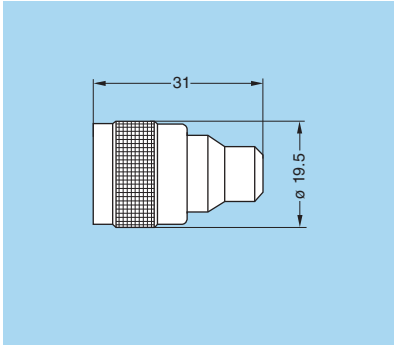

ACA Adaptor from LEMO socket to C plug

Part number	Weight (g)
ACA.00.250.NTL	32

Note: Non standard, on request only

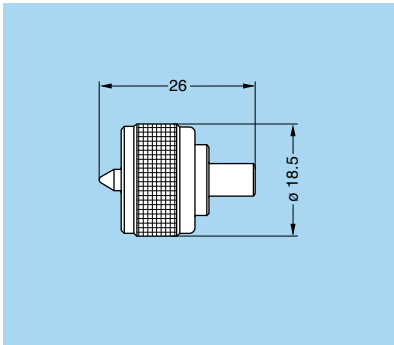
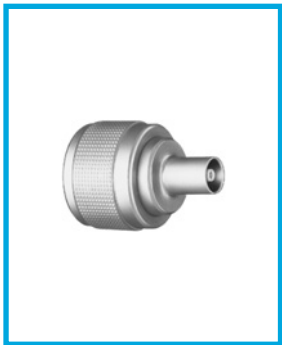

AGH Adaptor from LEMO socket to UHF plug

Part number	Weight (g)
AGH.00.250.NTL	13.8

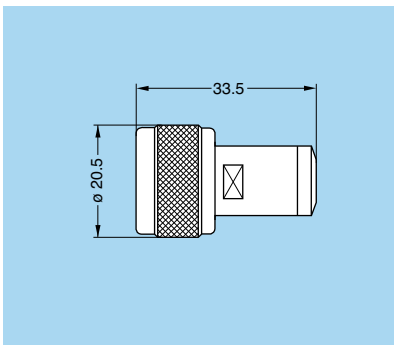

ANA Adaptor from LEMO socket to N plug

Part number	Weight (g)
ANA.00.250.NTL	38

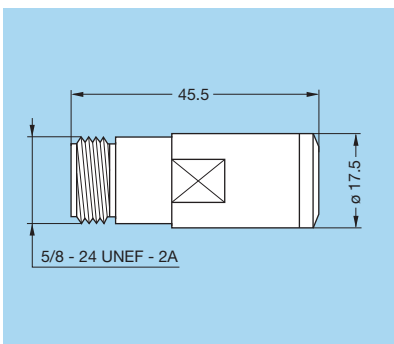

ANB Adaptor from LEMO socket to N socket

Part number	Weight (g)
ANB.00.250.NTM	61.7

Note: Non standard, on request only

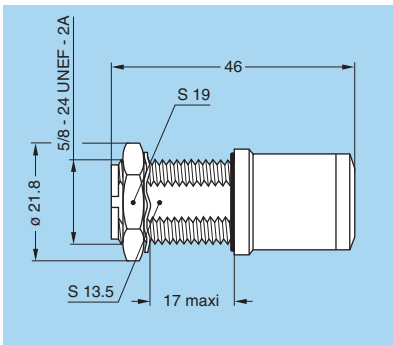

ANC Adaptor from LEMO socket to N fixed socket

Part number	Weight (g)
ANC.00.250.NTM	63.5

P8 Panel cut-out (page 38)

Note: Non standard, on request only

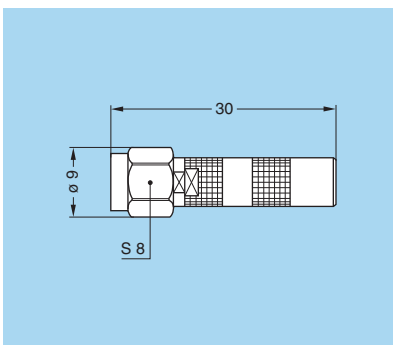
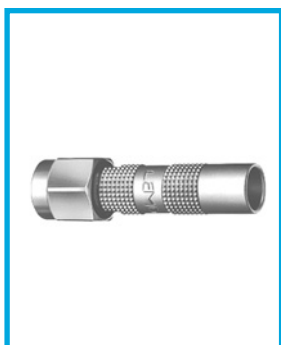

ASA Adaptor from LEMO socket to SMA plug

Part number	Weight (g)
ASA.00.250.NTL	4.9

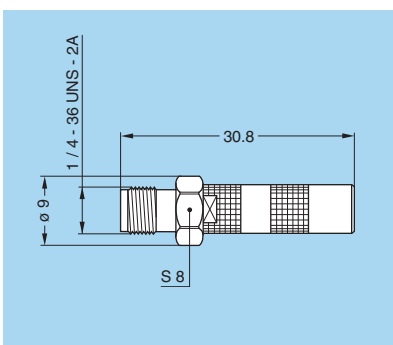

ASB Adaptor from LEMO socket to SMA socket

Part number	Weight (g)
ASB.00.250.NTM	4.6

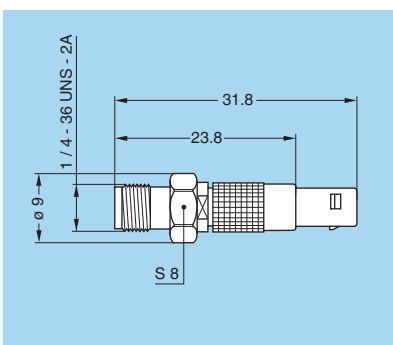
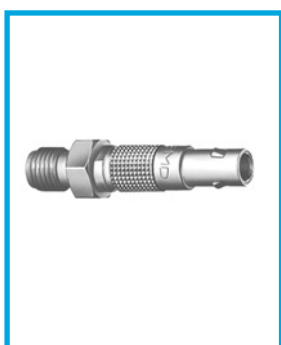

ASF Adaptor from LEMO plug to SMA socket

Part number	Weight (g)
ASF.00.250.NTA	4.6

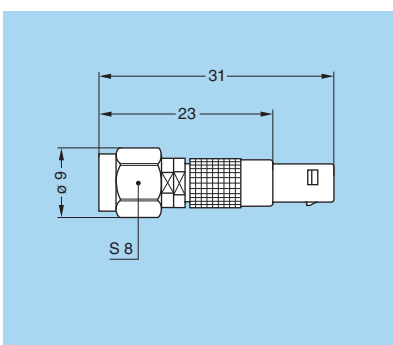

ASG Adaptor from LEMO plug to SMA plug

Part number	Weight (g)
ASG.00.250.NTC	4.9

Variant

Bend relief for models with collet (letter Z in the variant position)

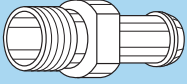
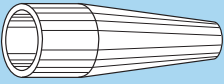
	Need to be ordered
	
Reference	Need to be ordered separately (see page 33)
C15Z	GMA.00.0●●.D●
C17Z	GMA.00.0●●.D●
C22Z	-
C27Z	GMD or GMB.00.0●●.D●
C31Z	GMD or GMB.00.0●●.D●
C52Z	GMA.0B.0●●.D●
K37Z	GMA.0B.0●●.D●
K42Z	GMA.0B.0●●.D●
D42Z	GMA.0B.0●●.D●
D52Z	GMA.0B.0●●.D●

Note: The “GMD” are thin bend reliefs (for very flexible cables)

Bend relief for models for cable crimping (no letter in the variant position) The bend relief can be fitted directly over the crimp ferrule

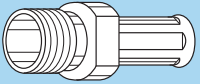
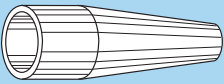
	Need to be ordered
	
Reference	Need to be ordered separately (see page 33)
E24	GMD or GMB.00.0●●.D●
E25	GMD or GMB.00.0●●.D●
E30	GMD or GMB.00.0●●.D●
E31	GMD or GMB.00.0●●.D●
E32	GMD or GMB.00.0●●.D●
E35	-
E44	-
E52	-
E56	-

Note: The “GMD” are thin bend reliefs (for very flexible cables)

Assembled cables

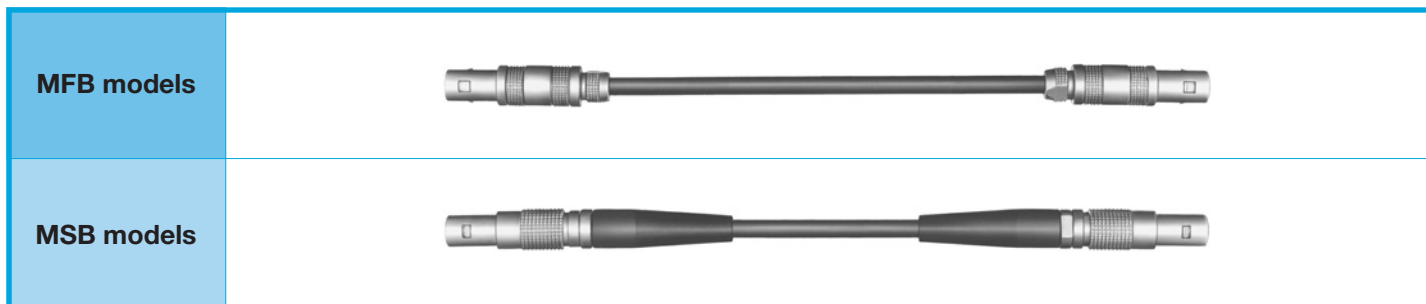

Delay lines

Part number	Delay (ns)	Part number
MFB.00.250.RTE005	0.5	MSB.00.250.RTE005
MFB.00.250.RTE010	1.0	MSB.00.250.RTE010
MFB.00.250.RTE020	2.0	MSB.00.250.RTE020
MFB.00.250.RTE030	3.0	MSB.00.250.RTE030
MFB.00.250.RTE040	4.0	MSB.00.250.RTE040
MFB.00.250.RTE050	5.0	MSB.00.250.RTE050
MFB.00.250.RTE060	6.0	MSB.00.250.RTE060
MFB.00.250.RTE080	8.0	MSB.00.250.RTE080
MFB.00.250.RTE100	10.0	MSB.00.250.RTE100
MFB.00.250.RTE160	16.0	MSB.00.250.RTE160
MFB.00.250.RTE200	20.0	MSB.00.250.RTE200
MFB.00.250.RTE320	32.0	MSB.00.250.RTE320
MFB.00.250.RTE640	64.0	MSB.00.250.RTE640

Assembled Cables

Part number	Length (cm)	Part number
MFB.00.250.LTE010	10	MSB.00.250.LTE010
MFB.00.250.LTE020	20	MSB.00.250.LTE020
MFB.00.250.LTE030	30	MSB.00.250.LTE030
MFB.00.250.LTE040	40	MSB.00.250.LTE040
MFB.00.250.LTE050	50	MSB.00.250.LTE050
MFB.00.250.LTE060	60	MSB.00.250.LTE060
MFB.00.250.LTE080	80	MSB.00.250.LTE080
MFB.00.250.LTE100	100	MSB.00.250.LTE100
MFB.00.250.LTE150	150	MSB.00.250.LTE150
MFB.00.250.LTE200	200	MSB.00.250.LTE200
MFB.00.250.LTE300	300	MSB.00.250.LTE300
MFB.00.250.LTE400	400	MSB.00.250.LTE400
MFB.00.250.LTE500	500	MSB.00.250.LTE500

Note: the standard cable used to manufacture these cable assemblies is according to IEC.50.2.1 standard. On request this type of cable can be replaced by other coaxial cables. Other cable lengths are available on request.

Accessories



Fitting of the cord

Slide the plug into the loop of the cord. Place the loop into the groove in front of the collet nut and tighten the loop.

BFG Caps for plug with or without keying

Part number	Weight (g)
BFG.00.100.PCSG	0.7

Note: upon request this cap can be supplied in black and the last letter "G" of the part number should be replaced with "N".

- Body material: Polyoxymethylen (POM) grey
- Cord material: Polyamid 6, grey
- O-ring material: Silicone rubber
- Maximum operating temperature: 100°C
- Watertightness: IP61 according to IEC 60529

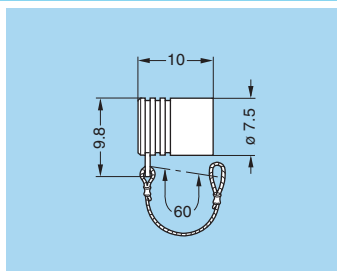

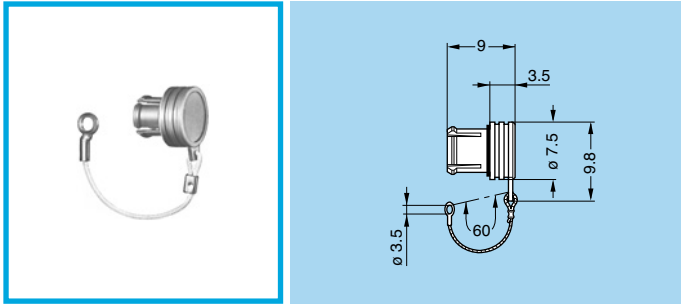

- Body material: Polyoxymethylen (POM) grey
- Cord material: Polyamid 6, grey

BRA Blanking cap for fixed socket and free straight socket

Part number	Weight (g)
BRA.00.200.PCSG	0.6

Note: upon request this cap can be supplied in black and the last letter "G" of the part number should be replaced with "N".

- O-ring material: Silicone rubber
- Maximum operating temperature: 100°C
- Watertightness: IP61 according to IEC 60529

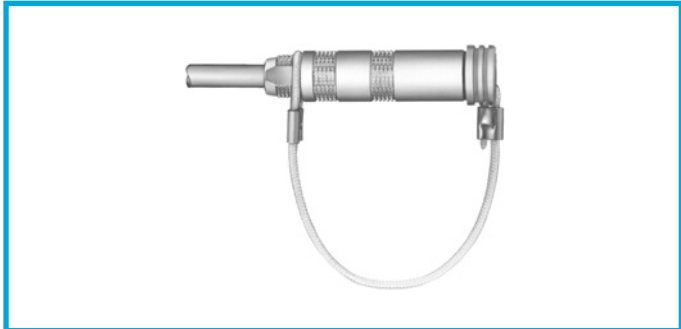

Fitting of the cord

Slide the socket into the loop of the cord. Place the loop into the groove in front of the collet nut and tighten the loop.

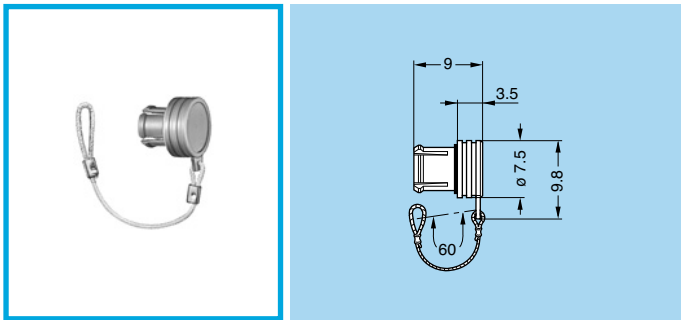

BRD Blanking cap for free socket

Part number	Weight (g)
BRD.00.200.PCSG	0.5

Note: upon request this cap can be supplied in black and the last letter "G" of the part number should be replaced with "N".

- Body material: Polyoxymethylen (POM) grey
- Cord material: Polyamid 6, grey
- O-ring material: Silicone rubber
- Maximum operating temperature: 100°C
- Watertightness: IP61 according to IEC 60529

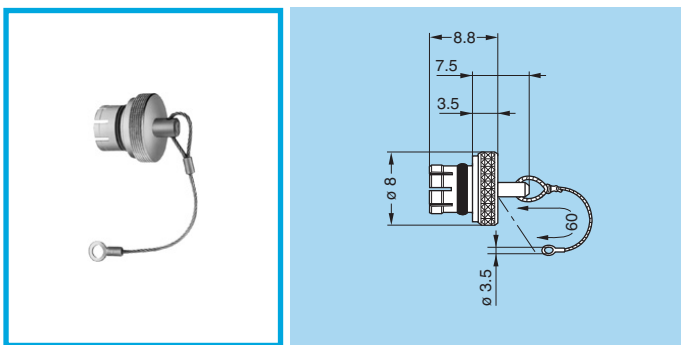

BRE Blanking cap for fixed socket, free socket and coupler

Part number	Weight (g)
BRE.00.200.NAS	6.5

- Body material: Brass (UNS C 38500), nickel-plated (3 µm)
- Cable material: Stainless steel
- O-ring material: Silicone rubber or FPM
- Maximum operating temperature: 250°C
- Watertightness: IP61 according to IEC 60529

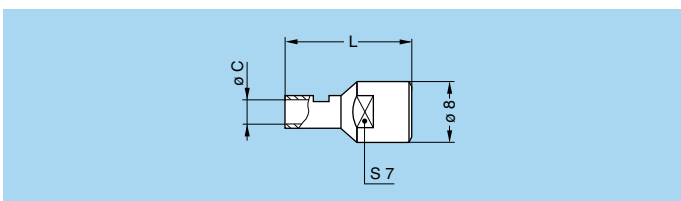

GCD Earthing cap

Part number	Cable group	Dim.	
		L	C
GCD.00.020.LA	1	12	2.0
GCD.00.032.LA	2-3-4	16	3.2
GCD.00.050.LA	6	19	5.0

Note: the shield braid of the cable should be soldered onto the back of the cap screwed on the socket outer shell.

- Material: Brass (UNS C 38500) gold-plated (0.5 µm)

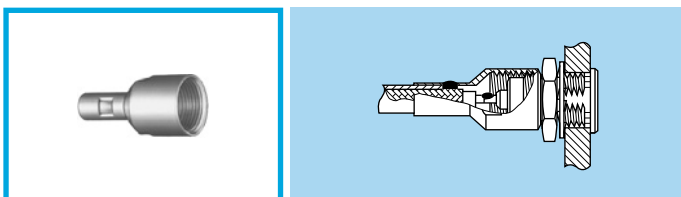

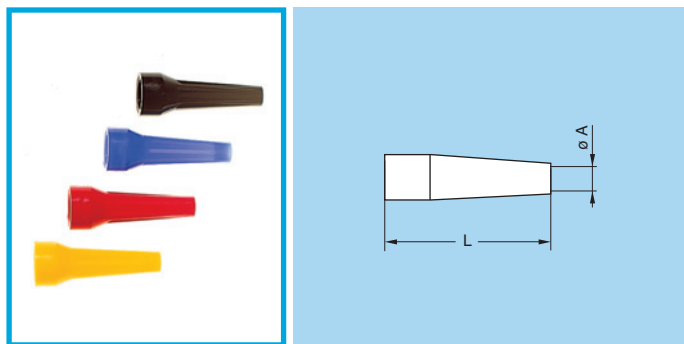

Note:

- a) for use with crimp models and nut for fitting a bend relief.
- b) the last letter of the part number “•” specifies the colour. Refer to the table below, for GRA washers, to define another colour and replace the letter “•” by the one corresponding to the colour required.
- c) material: Polyurethan (Desmopan 786)
- d) operating temperature: -40°C + 80°C

GM. Bend relief (Polyurethane)

Part number	Dim.		ø Cable		Nut for fitting the bend relief part nb
	A	L	max	min	
GMA.00.012.D•	1.2	22	1.4	1.1	FFM.00.130.LN
GMA.00.018.D•	1.8	22	2.1	1.8	FFM.00.130.LN
GMB.00.025.D•	2.5	22	2.8	2.5	FFM.00.130.LN
GMB.00.028.D•	2.8	22	3.1	2.8	FFM.00.130.LN
GMB.00.032.D•	3.2	22	3.5	3.2	FFM.00.130.LN
GMD.00.025.D•	2.5	22	2.8	2.5	FFM.00.130.LN
GMD.00.028.D•	2.8	22	3.1	2.8	FFM.00.130.LN
GMD.00.032.D•	3.2	22	3.5	3.2	FFM.00.130.LN
GMA.0B.025.D•	2.5	24	2.9	2.5	FFM.0B.130.LC
GMA.0B.030.D•	3.0	24	3.4	3.0	FFM.0B.130.LC
GMB.0B.035.D•	3.5	24	3.9	3.5	FFM.0B.130.LC
GMB.0B.040.D•	4.0	24	4.4	4.0	FFM.0B.130.LC
GMB.0B.045.D•	4.5	24	5.2	4.5	FFM.0B.130.LC

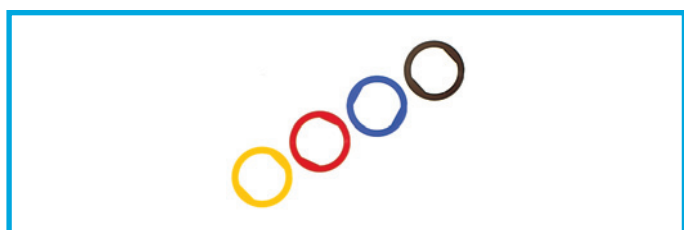

GRA Insulating washers

Part number	Weight (g)
GRA.00.269.G•	0.1

Note:

- a) sockets and plugs mounted on panels can be fitted with insulating washers. The nine colours available combined with those for the bend reliefs makes colour coding possible.
- b) the last letter of the part number “•” specifies the colour. Refer to the table below to define another colour and replace the letter “•” by the one corresponding to the colour required.
- c) material: Polyamid
- d) operating temperature: -40°C + 80°C

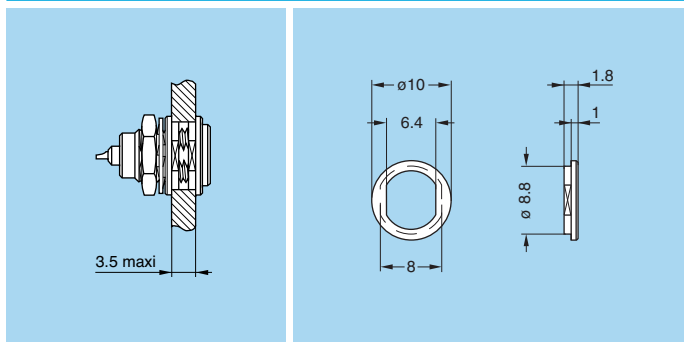

Ref.	Colour	Ref.	Colour	Ref.	Colour
A	blue	J	yellow	R	red
B	white	M	brown	S	orange
G	grey	N	black	V	green

Spare Parts

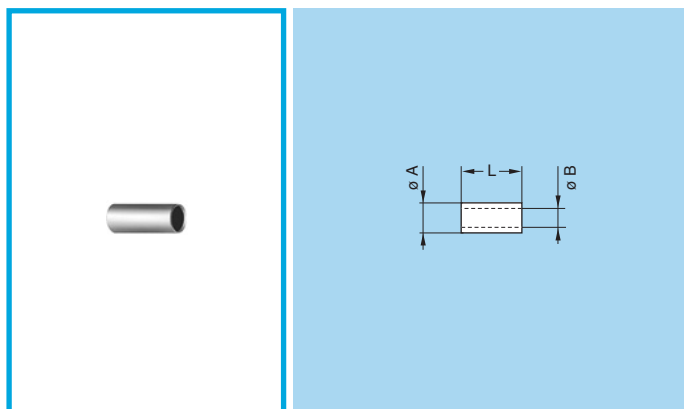

FFS Crimp ferrule

Part number	Cable group	Dim.		
		øA	øB	L
FFS.00.160.DN	1	3.1	2.4	8
FFS.00.161.MN	2-3-4	3.8	3.05	8
FFS.00.162.DN	8	4.4	3.4	8
FFS.00.163.DN	5	5.3	4.4	8
FFS.00.164.DN	6	6.2	5.25	11
CRK.0A.160.DN	7	6.2	5.5	11

Note: sockets and plugs to be crimped are always supplied with a crimp ferrule. To order this accessory separately, use the above part numbers.

• Material: Copper (UNS C 18700) nickel-plated (3µm)

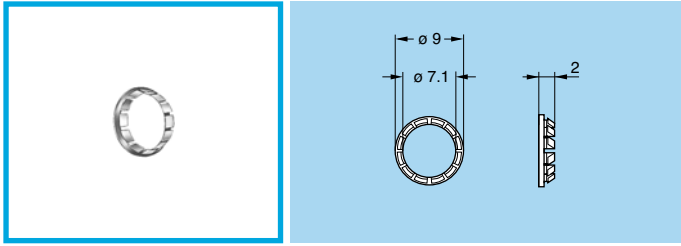

GBB Tapered washer

Part number	Weight (g)
GBB.00.250.LN	0.2

Note: to order this accessory separately, use the above part number.

- Material: Brass (UNS C 38500) nickel-plated (3 µm)

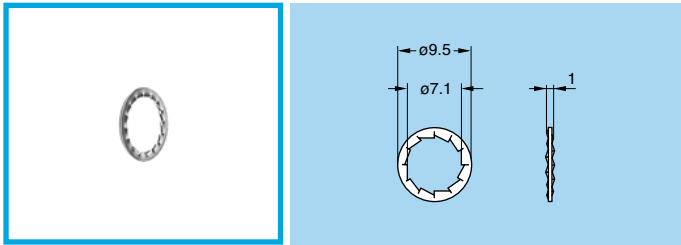

GBA Locking washer

Part number	Weight (g)
GBA.00.250.FN	0.2

Note: sockets and plugs are always supplied with a locking washer. To order this accessory separately, use the above part number.

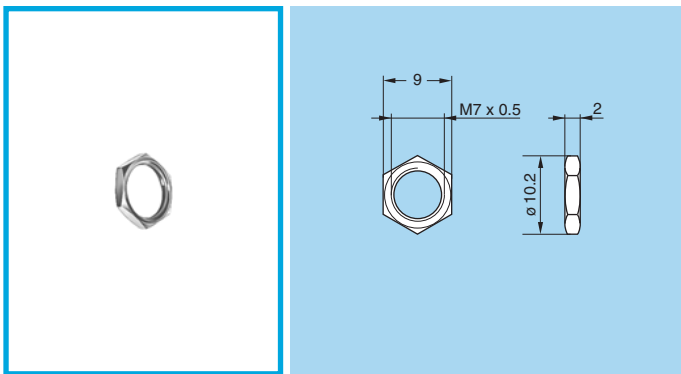

GEA Hexagonal nut

Part number	Weight (g)
GEA.00.240.LN	0.6

Note: sockets and plugs are supplied with a hexagonal nut as standard. To order this accessory separately, use the above part number. The last letters "LN" of the part number refer to the nut material and treatment. If a nut in aluminium alloy is desired, replace the last letters of the part number by "PT".

- Material:
 - Brass (UNS C 38500) nickel-plated (3 µm)
 - Aluminium alloy natural anodized

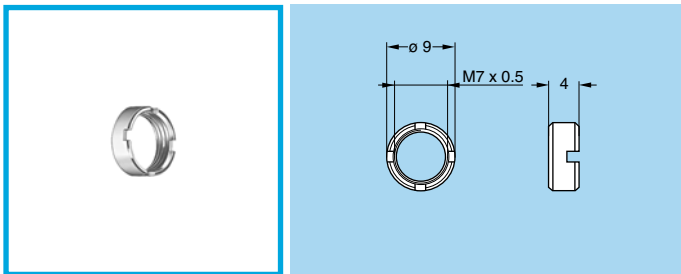

GEB Round nut

Part number	Weight (g)	Standard for models
GEB.00.240.LN	0.8	ECP, ESG

Note: to order this accessory separately, use the above part number.

- Material: Brass (UNS C 38500) nickel-plated (3 µm)

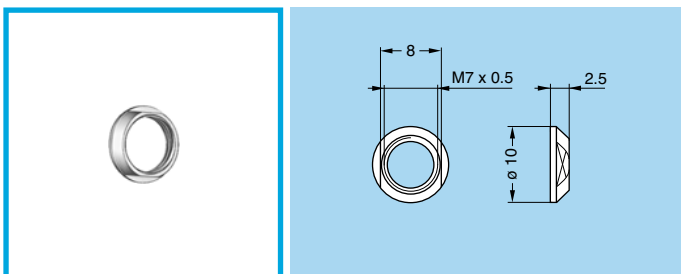

GEC Conical nut

Part number	Weight (g)
GEC.00.240.LN	0.6

Note: to order this accessory separately, use the above part number.

- Material: Brass (UNS C 38500) nickel-plated (3 µm)

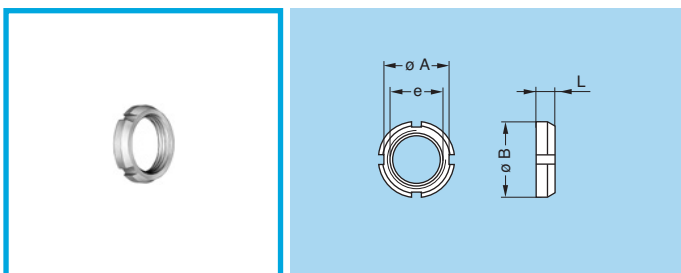

GEG Notched nut

Part number	Dimensions (mm)				Standard for models
	A	B	e	L	
GEG.00.240.LN	8.7	10	M7 x 0.5	2.5	EPE, EPS, EPR, PES, PFS, PLK, VPS, HEP

Note: to order this accessory separately, use the above part numbers.

- Material: Brass (UNS C 38500) nickel-plated (3 µm)

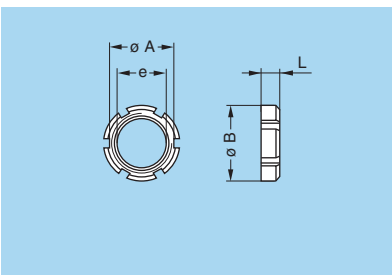

GEB Slotted nut

Part number	Dimensions (mm)				Standard for models
	A	B	e	L	
GEB.00.242.LN	8.5	10	M7 x 0.5	2.5	ELF, XBG, XRG, XSG, EXG

Note: to order this accessory separately, use the above part numbers.

- Material: Brass (UNS C 38500) nicked-plated (3 μ m)

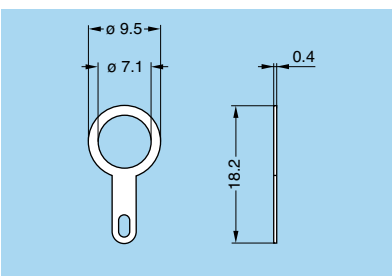

GCA Earthing Washer

Part number	Weight (g)
GCA.00.255.LT	0.2

- Material: Brass (UNS C 27400) treated CuSnZn (2 μ m)

Tooling

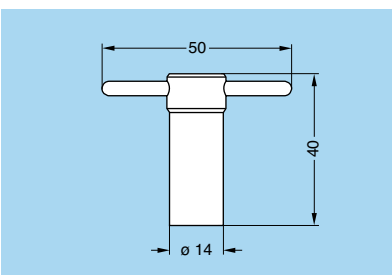
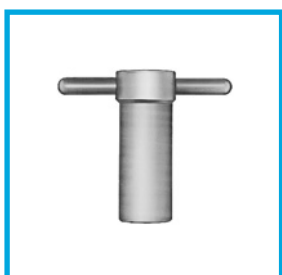

DCG Spanner for hexagonal nut

Part number	Part number of the nut
DCG.91.149.0TN	GEA.00.240.LN

- Material: Blackened steel

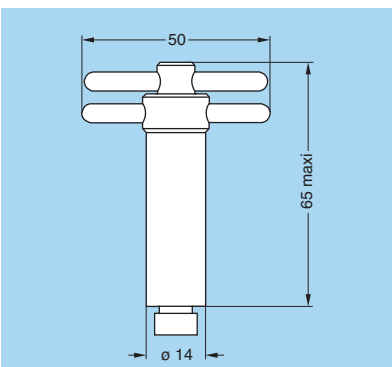
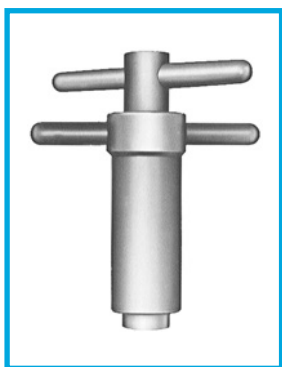

DCA Spanner for hexagonal nut with locator for flats on socket thread

Part number	Part number of the nut
DCA.91.149.0TN	GEA.00.240.LN

- Material: Blackened steel

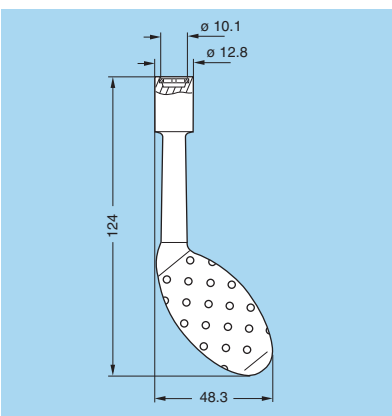
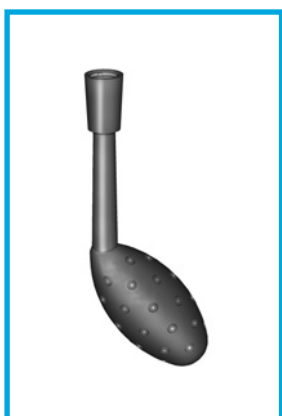

DCH Spanner for notched nut

Part number	Part number of the nut
DCH.91.101.PA	GEG.00.240.LN

- Material: blue polyurethane

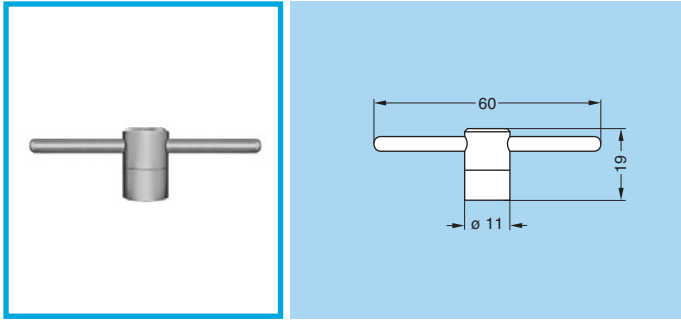

DCB Spanner for slotted nut

Part number	Part number of the nut
DCB.91.455.0LN	GEB.00.242.LN

- Material: Steel, nicked plated

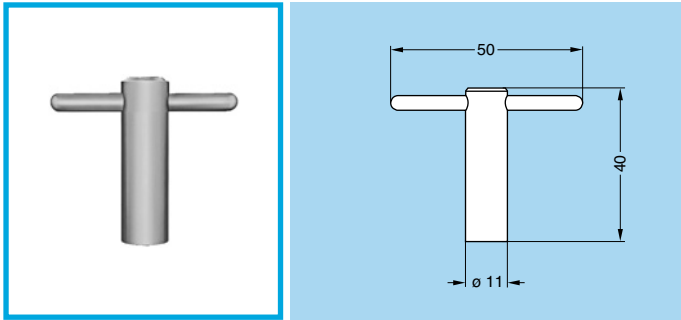

DCB Spanner for round nut

Part number	Part number of the nut
DCB.91.119.0TN	GEB.00.240.LN

- Material: Blackened steel

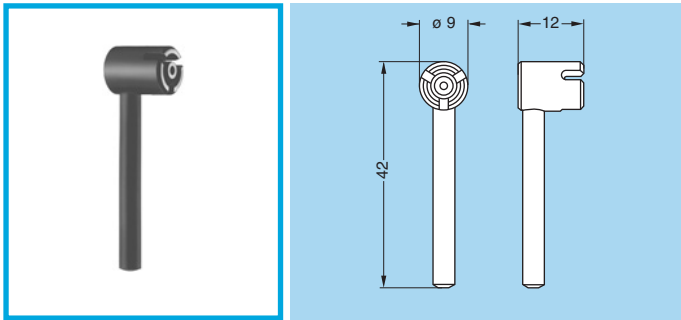

DCN Spanner for assembling plug with 3 latches

Part number
DCN.91.905.0TK

- Material: Blackened steel

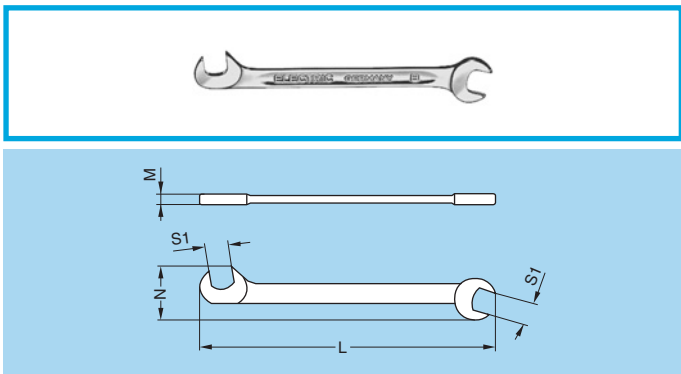

DCP Flat spanner for collet nut

Part number	Dimensions			
	L	M	N	S1
DCP.99.045.TC	70	2	10.5	4.5
DCP.99.050.TC	78	2	12.6	5.0
DCP.99.055.TC	78	2	12.6	5.5
DCP.99.060.TC	78	2	12.6	6.0

- Material: Chrome-plated steel

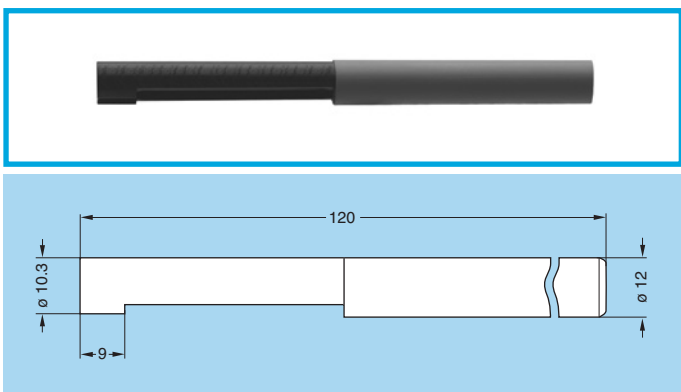

DCR Extraction tool for plugs

Part number
DCR.91.106.0PN

- Material: Black Polypropylene

Note: this type of tool has been produced in order to facilitate the mating and unmating of plugs and is particularly useful in high density applications.



DPE Crimping tool with die

Part number	Cable group	Crimp collet ref.
DPE.99.000.0K	Crimping tool with no die	
DPE.99.123.1K	1	E24
DPE.99.123.8K	2-3-4	E30, E31
DPE.99.124.3K	8	E35
DPE.99.125.2K	5	E44
DPE.99.176.2K	6-7	E52, E56

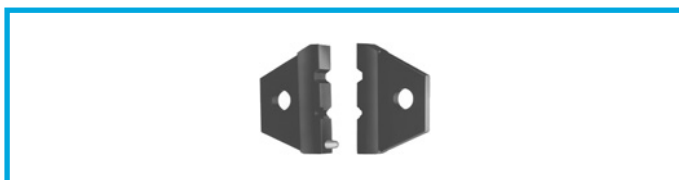

DPN Dies

Part number	Cable group	Die dimension				
		For contacts			For shield	
		A	B	L	A	B
DPN.99.123.1K	1	1.29	0.91	2.0	3.10	2.70
DPN.99.123.8K	2-3-4	1.29	0.91	2.0	3.80	3.30
DPN.99.124.3K	8	1.29	0.91	2.0	4.36	3.78
DPN.99.125.2K	5	1.29	0.91	2.0	5.20	4.50
DPN.99.176.2K	6-7	1.71	1.21	2.5	6.20	5.37

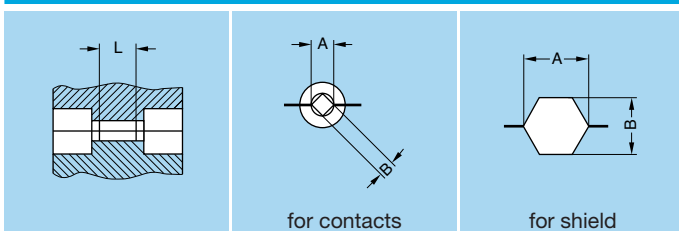

- Dies material: Blackened steel

Panel cut-outs

Panel cut-out

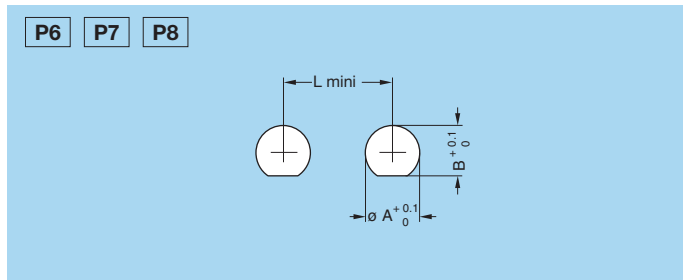
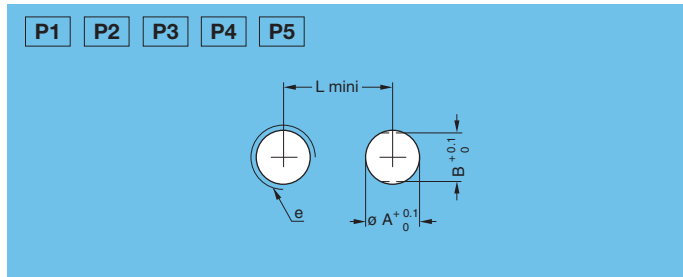

Cut-out	Model	Dimensions			
		A	B	L	e
P1	ECP-EPE-EPR-EPS-ERC EWF-EXG-FAB-HGP HGW-SWH-VPS-XBG XSG-XRG	7.1	-	14.5	-
P2	EWV	-	-	12.0	M7x0.5
P3	ERC-ERX	-	-	9.0	M7x0.5
P4	ERT	6.92 ^{+0.02}	-	-	-
P5	EHP-ELF-ERA-ERE-ERM ERN-FAA-FAN-PES-PFS PLK-PSA-PSG-PSS ¹⁾	7.1	6.4	14.5	-
P6	ABB	9.7	9.0	15.0	-
P7	ABD	12.9	11.7	20.5	-
P8	ANC	16.1	13.7	24.0	-

Note: 1) If these models are used with a tapered washer GBB, the panel cut-out must be according P1.

Recommended mounting nut torque: 1 Nm.

PCB drilling pattern

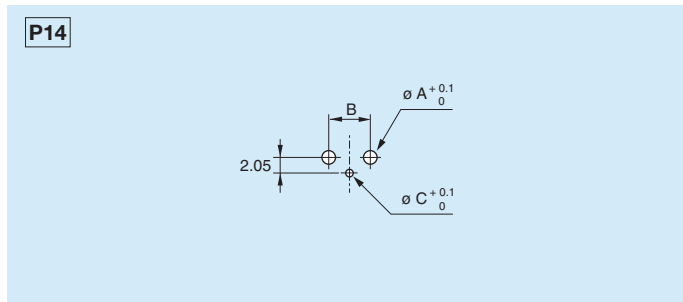
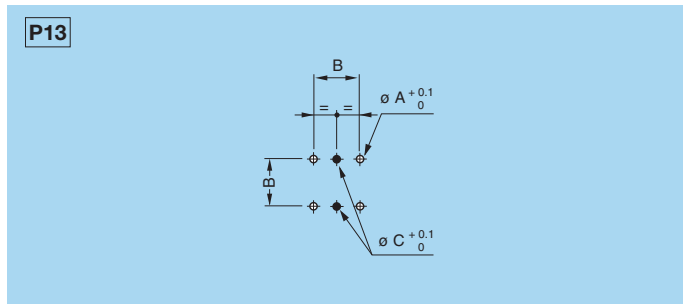
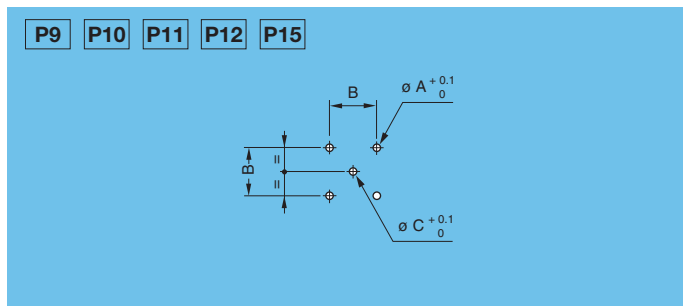

Drill	Model	Dimensions		
		A	B	C
P9	EPN	1.0	5.08	-
P10	EPA-EPB-EPC-EPL-EPK EPM-FPL	0.8	5.08	0.8
P11	FPA	0.8	5.08	1.1
P12	EPE-EPS-EPR-XSG	0.8	5.08	0.8
P15	HEP, EXG	1.3	5.08	0.8
P13	EPY	0.8	5.08	0.8
P14	XRG	1.8	5.5	0.8

Cable assembly

Terminating of plugs and straight sockets with cable collet M1 M2 M3

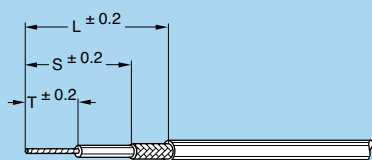
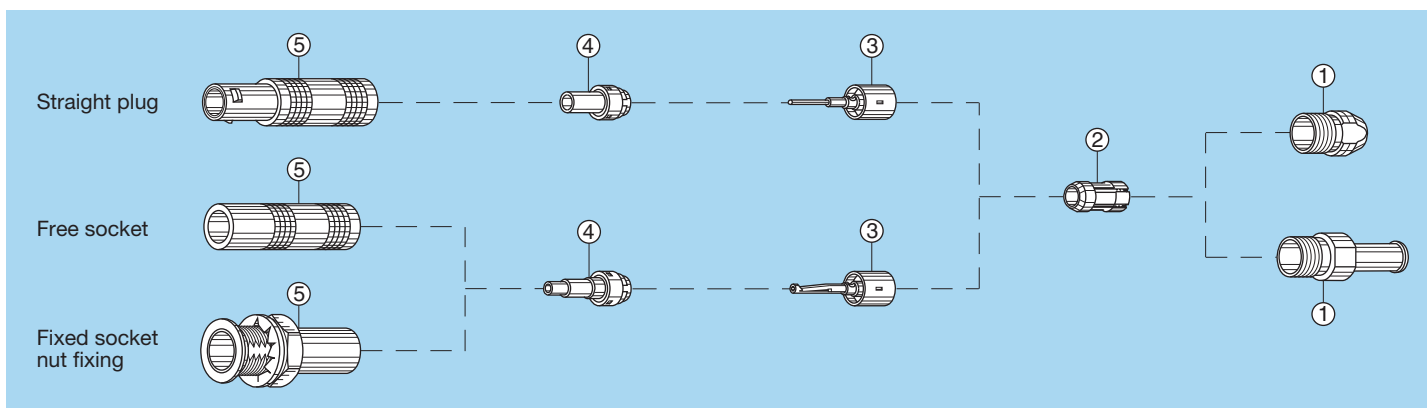

1. Cable preparation

First place the bend relief (if to be used) on the cable. Strip the cable according to dimensions below.

Cable group	M1			M2			M3		
	T	S	L	T	S	L	T	S	L
1-2-3-4-8	4	4.5	9	-	-	-	5	5	8
6-7	-	-	-	7.5	8.5	13	-	-	-

2. Cable termination

- 2.1 Place the collet nut ① and the collet ② on the cable. Fold back the shield braid onto the conical part of the collet, and trim to the outer edge of the collet
- 2.2 Slide the subassembly ③ to trap the shield braiding and solder the central conductor into the contact.
- 2.3 Slide the insulator ④ onto the subassembly ③ until it rests against the earthing sleeve of the subassembly ③.
- 2.4 Slide the assembly into the connector outer shell ⑤. Screw the collet nut ① into the connector outer shell ⑤ using the appropriate tool and tighten to a torque of 0.25 Nm (see "Tooling" on page 35, 36 and 37). Push the bend relief (if used) onto the collet nut.

Note: these terminating instructions apply to the following models:
M1 = FFA, FFE, FFF, PCA, PSA
M2 = FFY
M3 = FFC

Terminating of plugs and straight sockets with cable crimping (crimp contact) M4

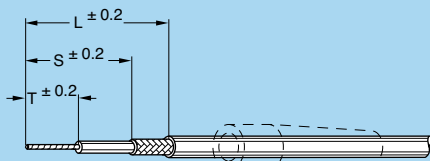
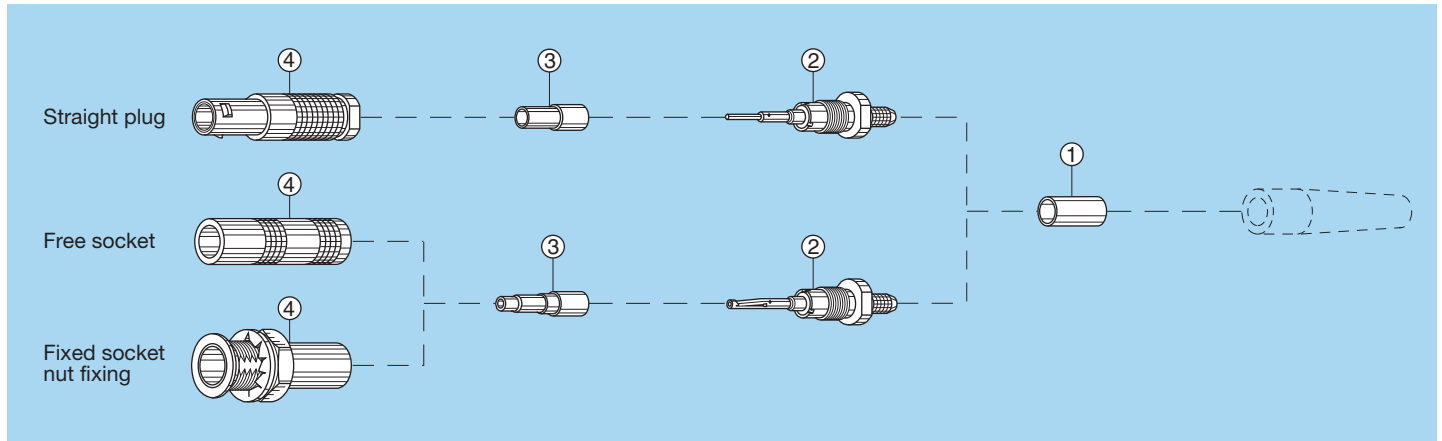

1. Cable preparation

First place the bend relief (if to be used) on the cable. Strip the cable according to dimensions below.

Cable group	M4		
	T	S	L
1-2-3-4-8	7	15	19.5
6-7	7	15	21.5

2. Cable termination

- 2.1 Place crimp ferrule ① on the cable. Widen the shield braid. Slide the subassembly ② into the cable until the insulator rests against the dielectric and the cable conductor is visible through the contact inspection hole.
- 2.2 Crimp the contact with the LEMO crimping tool using the square hole (see "Tooling" on page 37). Gently pull the cable in order to check the crimping.
- 2.3 Slide the crimp ferrule ① onto the shield until it rests against the crimp backnut of the subassembly ②. Crimp with the same LEMO crimping tool using the hexagonal opening. Slide the insulator ③ onto the subassembly ②.
- 2.4 Slide the assembly into the connector shell ④ and screw it onto the subassembly ②. Tighten using the appropriate tool to a torque of 0.25 Nm (see "Tooling" on page 35, 36 and 37). Push the bend relief (if used) onto the crimp ferrule ①.

Note: these terminating instructions apply to the following models:
M4 = FFS, FFV, PCS, PSS, PES

Terminating of plugs and straight sockets with cable crimping (solder contact) M5

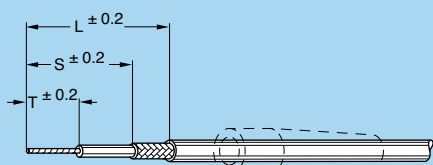
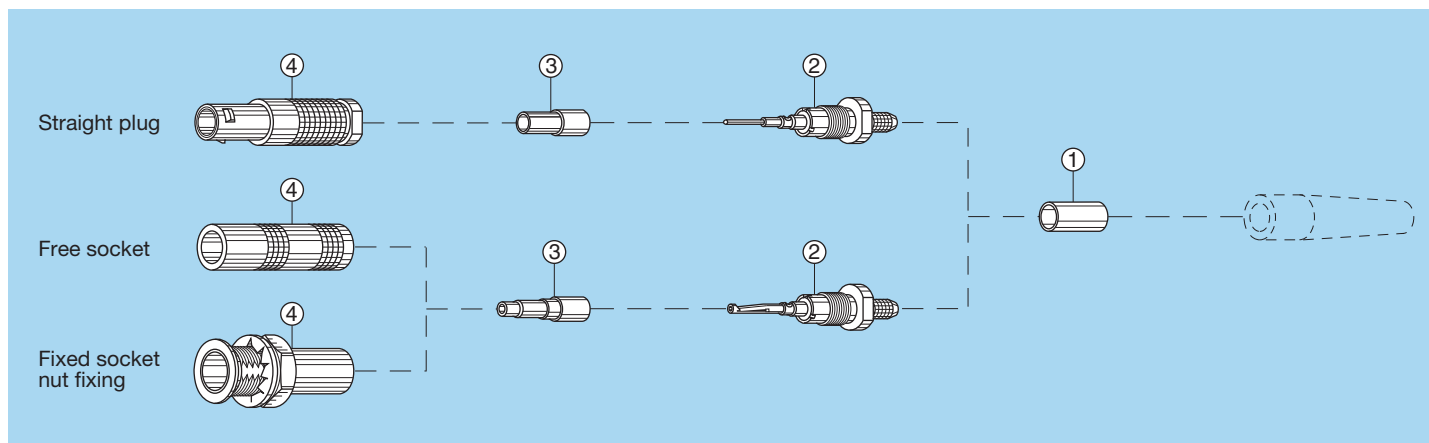

1. Cable preparation

First place the bend relief (if to be used) on the cable. Strip the cable according to dimensions below.

Cable group	M5		
	T	S	L
1-2-3-4-8	5	12	17
6-7	5	12	19

2. Cable terminating

2.1 Place the crimp ferrule ① on the cable. Widen the shield braid. Slide the subassembly ② over the cable until the insulator rests against the dielectric and the cable conductor is visible through the contact solder hole.

2.2 Solder the conductor through the hole.

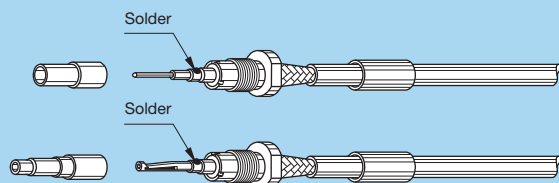

2.3 Slide the crimp ferrule ① onto the shield until it rests against the crimp backnut of the subassembly ②. Crimp with the LEMO crimping tool using the hexagonal opening (see "Tooling" on page 37). Slide the insulator ③ onto the subassembly ②.

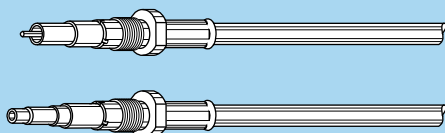

2.4 Slide the assembly into the connector shell ④ and screw it onto the subassembly ②. Tighten using the appropriate tool to a torque of 0.25 Nm (see tooling on pages 35, 36 and 37). Push the bend relief (if used) onto the crimp ferrule.

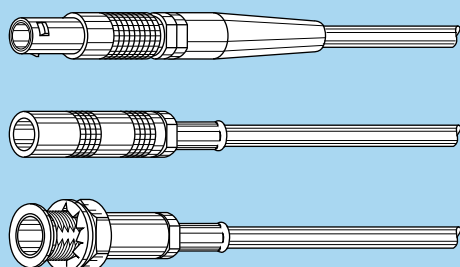

Note: these terminating instructions apply to the following models:
M5 = FFS, FFV

Terminating of elbow plugs (90°) with cable collet (solder contact) **M6** and cable crimp (solder contact) **M7**

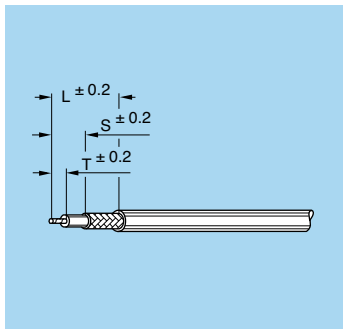
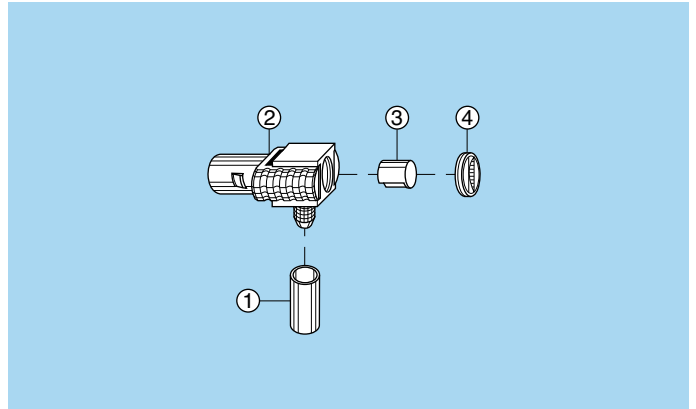
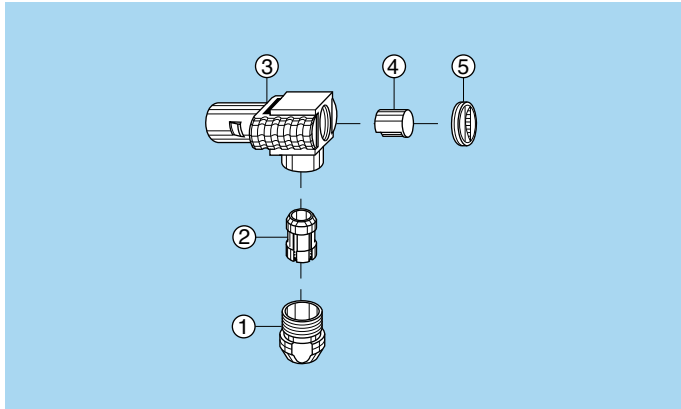

1. Cable preparation

First place the bend relief (if to be used) on the cable. Strip the cable according to dimensions below.

Cable group	M6		
	T	S	L
1-2-3-4-8	1	3.5	6.5

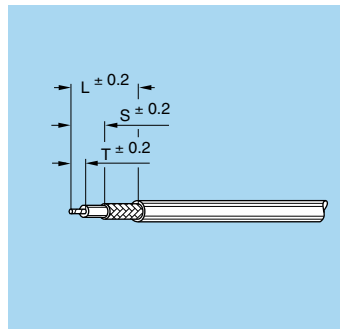

1. Cable preparation

First place the bend relief (if to be used) on the cable. Strip the cable according to dimensions below.

Cable group	M7		
	T	S	L
1-2-3-4-8	1	4.5	9
6-7	3	4.5	11

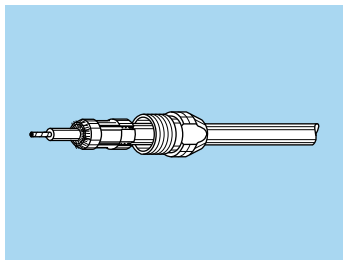

2. Cable terminating

2.1 Place the crimp ferrule ① and collet ② on the cable. Fold back the shield braid onto the conical part of the collet, and trim to outer edge of the collet.

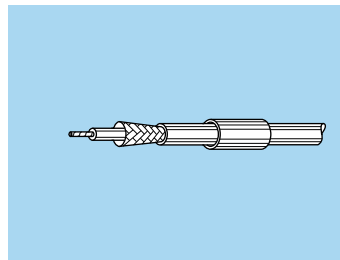

2. Cable terminating

2.1 Place the cable crimp ferrule ① on the cable and widen the braiding.

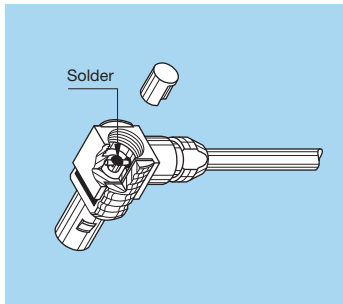

2.2 Slide the assembly into the connector shell ③ and tighten the collet nut ① using the appropriate tool to a torque of 0.25 Nm (see "Tooling" on page 35, 36 and 37). Check that the cable conductor rests in the contact slot, solder the conductor through the hole.

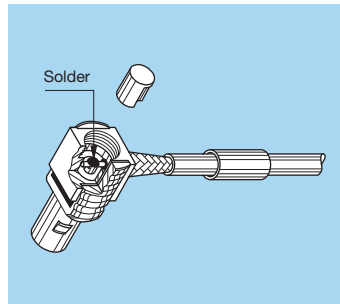

2.2 Slide the cable into the connector shell ②. Check that cable conductor rests in the contact slot, tin solder the conductor through the hole. Slide the crimp ferrule ① over the braiding until it reaches the connector shell ②. Crimp with the LEMO crimp tool using the hexagonal opening (see "Tooling" on page 37).

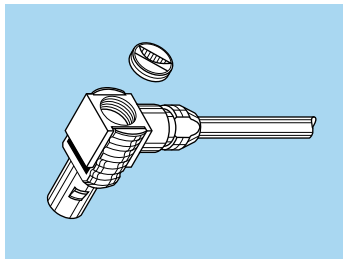

2.3 Place the insulating sleeve ④ over the soldered contact.

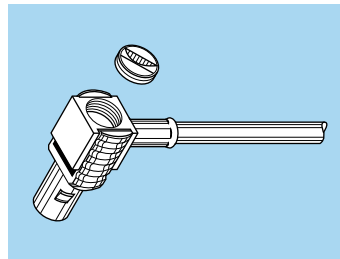

2.3 Place the insulating sleeve ③ over the soldered contact.

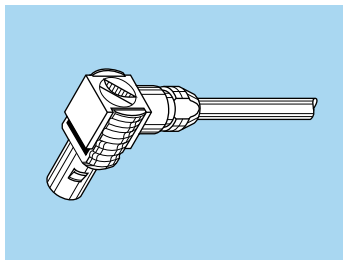

2.4 Close the access hole with the flat screw ⑤. Push the bend relief (if used) onto the collet nut ①.

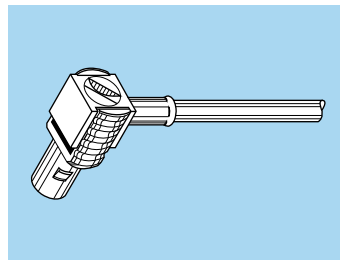

2.4 Close the connector hole with the flat screw ④. Push the bend relief (if used) onto the crimping tube ①.

Note: these terminating instructions apply to the following models:

M6 = FLA

Note: these terminating instructions apply to the following models:

M7 = FLS, FLV

X-ON Electronics

Largest Supplier of Electrical and Electronic Components

Click to view similar products for [Circular Push Pull Connectors](#) category:

Click to view products by [LEMO](#) manufacturer:

Other Similar products are found below :

[FEA.1B.308.CYCD72Z](#) [D38999/20ZC8JA](#) [D38999/20ZG35PN-LC](#) [D38999/20ZG39BN](#) [D38999/20ZG41PN-LC](#) [D38999/20ZH21SA](#)
[D38999/20ZH53SA](#) [D38999/20ZJ24SA](#) [D38999/20ZJ29PA-LC](#) [D38999/20ZJ43HA](#) [D38999/20ZJ43PA-LC](#) [D38999/20ZJ61PA-LC](#)
[D38999/24ZF11SA-LC](#) [D38999/24ZF32BA](#) [D38999/24ZF32PA-LC](#) [D38999/24ZF32SA-LC](#) [D38999/24ZF35BA](#) [D38999/24ZF35SA-LC](#)
[EXG.00.250.NTNY](#) [FFA.00.250.CTAZ](#) [FFA.1S.302.CLAZ](#) [FFA.1Y.410.CTAC52](#) [FFA.2S.310.ZLA](#) [FFG.1B.302.CLAD52Z](#)
[FFG.1B.304.CLAD42Z](#) [FFG.1B.304.CLAD72Z](#) [FFG.1B.308.CLAD42Z](#) [FGA.1B.304.CLAD62Z](#) [FGA.1B.304.CYCD72Z](#)
[FGA.1B.305.CLAD76](#) [FGA.1B.306.CYCD72](#) [FGA.1B.307.CYCD72Z](#) [FGA.1B.308.CLAD76Z](#) [FGA.1B.308.CYCD42Z](#)
[FGA.1B.308.CYCD52Z](#) [FGA.1B.308.CYCD72Z](#) [FGA.1B.310.CLAD42](#) [FGA.1B.310.CLAD52Z](#) [FGA.1B.316.CLAD42](#)
[FGA.1B.316.CLAD62Z](#) [FGA.1B.316.CLAD76](#) [FGB.0B.307.CYCD31Z](#) [FGB.1B.302.CLAD72](#) [FGB.1B.303.CYCD62](#) [FGB.1B.305.CLAZ](#)
[FGB.1B.307.CYCD62Z](#) [FGB.1B.316.CLAD42](#) [FGC.0B.309.CLAD56](#) [FGC.1B.304.CLAD52Z](#) [FGC.1B.305.CLAD52Z](#)