

**Panasonic®**

 **-IMager**

**3D Image Sensor**  
**Model No. EKL3104**

**User's Manual**

**Version 1.20**

**2010. 9. 30**

## Contents

<b>1.Safety Precautions</b>	3
<b>2.Operating Precautions</b>	4
<b>3.Other Precautions</b>	5
<b>4.Maintenance</b>	5
<b>5.Included Items</b>	6
<b>6.Parts Name</b>	6
<b>7.Device Installation</b>	7
<b>8.Startup and Shutdown Procedures</b>	9
<b>9.Specifications</b>	12
<b>10.Provision on Export Trade Control</b>	13
<b>11.Special Notice</b>	14
<b>12.Modification History</b>	15

### Notice

- This manual and the software are copyrighted by Panasonic Electric Works Co., Ltd.
- Reproduction of this manual in any form without prior approval is strictly prohibited.
- *Windows® and Windows Vista® are registered trademarks of Microsoft Corporation in the United States and/or other countries.*
- *Pentium® is registered trademarks of Intel Corporation in the United States and/or other countries.*
- Suggested use of products and contents of this manual may change without notice.

# 1.Safety Precautions

THESE WARNINGS MUST BE STRICTLY OBSERVED  
TO PREVENT INJURY TO HUMANS OR DAMAGE TO PROPERTY.

 **Warning** MISUSE OF THIS PRODUCT MAY RESULT IN DEATH OR SERIOUS INJURY.

Our company is committed to making products of the highest quality and reliability. Nevertheless, all electrical components are subject to natural deterioration, and durability or characteristics of a product will depend on the operating environment and conditions of use. Continued use after such deterioration could lead to overheating, smoke or fire. Always use the product in conjunction with proper fire-prevention, safety and maintenance measures to avoid accidents, reduction in product life expectancy or break-down.

Example :

- Safety equipments and devices
- Traffic signals
- Burglar and disaster prevention
- Control or safety device for automotive or train etc.

Head the following precautions to prevent injury or accidents.

- 1) Do not use this product under any circumstances in which the range of its ratings, environment conditions or other specifications are exceeded. Such use may generate abnormally high levels of heat, emit smoke, etc., possibly resulting in damage to circuitry or other accident.
- 2) Do not use the product if it has been disassembled, remodeled or modified.  
This could cause fire or accidents (Electrical shock etc.).
- 3) Do not insert anything in this products' openings.
- 4) This product is designed for indoor use. Do not use it in any outdoor environment or in places where it could be in contact with water.
- 5) Always connect the sensor unit (USB, AC adaptor) before plugging in the power supply.
- 6) Always use an AC adaptor as specified on page 7, and ensure it is properly connected.  
Incorrect connections may cause malfunctions, generate abnormal high levels of heat, emit smoke, etc., possibly resulting in fire or causing electric shocks.
- 7) If smoke or smell should come out from the product, stop the usage immediately. If you continue, it could cause fire.

 **Caution** MISUSE OF THIS PRODUCT MAY RESULT IN INJURY TO USERS OR DAMAGE TO PROPERTY.

- 1) Make sure to install the product in a place that can support its weight (Mass). Any fall may cause accidents resulting in damages to the product or its surroundings. Therefore, for safety reasons, use the fall prevention wire or the wiring fixation clamp for installation for safety reasons .
- 2) Ensure a periodical maintenance.  
If the screws get rusted or loose, the product may fall and be damaged.
- 3) Do not use or store in places where condensation or freezing can occur or near a cooling or heating system. Do not leave the product exposed to direct sunlight for a prolonged period.
- 4) Please ensure a proper fixation of the product's wires using the provided items.  
Otherwise, it could cause an accident.

## 2. Operating Precautions

### 2.1 Basic Precautions

The 3D Image Sensor calculates the distance to a target by measuring the "Time-of-Flight" of near-emitted infrared rays. Efficiency and reliability of the system may vary depending on actual operating conditions. Always consider the following factors:

- 1) High reflectance target:  
For example if the target is close to the sensor (closer than 1.2m(3.94ft)) or in case the sensor receives light reflected by a mirror, the amount of power received increases considerably and may cause a saturation of the CCD element, resulting in distance measuring problems or errors.  
Besides, the measuring errors can also occur in the target's surrounding area.
- 2) Intense ambient illumination:  
The range resolution may diminish if a light source (such as sunlight, incandescent light or heater etc.,) whose emission spectrum, containing near-infrared frequencies exceeding the specifications, exists inside the detection area of the sensor.  
If the light source is too powerful, the CCD element in the sensor unit could saturate, resulting in distance measuring errors or malfunctions.
- 3) Fast moving targets:  
Fast moving targets may produce distance measuring errors from miss calculation at the outline of the target.
- 4) Distance from wall or floor:  
If wall or floor is close to the sensor (closer than 1.2 m (3.94ft)), it may produce distance measuring errors from reflection of emitted near-infrared rays.
- 5) Other precautions:  
The range resolution may diminish depending on the target's reflectance, distance to the sensor or position.

### 2.2 Usage and Storage Conditions

- 1) This product is destined for indoor use only. Do not install or store in outdoor environments.
- 2) This product is neither waterproof nor dustproof. Do not use or store in the following environments:
  - a) Places with high humidity level, high temperature, low temperature
  - b) Places exposed to corrosive gas, dust, gasoline, chemicals (including detergent) or water vapor.
  - c) Places where the sensor would be exposed to condensation or freezing.
- 3) Avoid exposing the product to shocks, vibration which could cause malfunctions.
- 4) Do not touch the front panel or the lens with your hands. It could cause reduced performance. Do not place any cover on the sensor's front panel.
- 5) Do not use in environments with temperatures above 50 °C(122° F), the unit may malfunction. Always allow for proper ventilation. If installed on a wall or a rack, please leave at least 10cm(3.94inch) between the product's vent and closest wall and allow air to freely circulate around it.

### 3. Other Precautions

- 1) Please handle this product with extreme care. It may be damaged by shocks or a fall.
- 2) Please avoid applying pressure or impacts to the front panel or the lens that might deform the product's shape, causing operating errors or reduced performance.
- 3) Operating errors can be caused by electric noise from static electricity, lightning, cell phone, amateur radio, broadcasting offices etc...
- 4) This product does not have the USB2.0 authentication.  
Use it only when the above -mentioned configuration and environments have been verified.
- 5) The USB drivers, range image display software, library for application software development and installation manual are copyrighted by Panasonic Electric Works Co., Ltd. ("PEW").  
Moreover, PEW provides the software as is, with no warranty as to its functionality, and disclaims any liability or responsibility for damage resulting from its use.
- 6) Be careful to protect privacy when using the images captured with this product.

#### 7) FCC Compliance Statement

This device complies with part 15 of the FCC rules. Operation is subject to the following two conditions: (1) this device may not cause harmful interference, and (2) this device must accept any interference received, including interference that may cause undesired operation.

NOTE: This equipment has been tested and found to comply with the limits for a Class A digital device, pursuant to part 15 of FCC Rules. These limits are designed to provide reasonable protection against harmful interference when the equipment is operated in a commercial environment. This equipment generates, uses, and can radiate radio frequency energy and, if not installed and used in accordance with the instruction manual, may cause harmful interference to radio communications. Operation of this equipment in a residential area is likely to cause harmful interference in which case the user will be required to correct the interference at his own expense.

#### 8) Classification of ITE (CISPR 22)

##### Warning

This is a class A product. In a domestic environment this product may cause radio interference in which case the user may be required to take adequate measures.

- 9) This device is for industrial use only. It can only fulfill its function, when it is installed with other equipment. It must be installed by professional personal.

### 4. Maintenance

Always turn off the power supply before maintenance, otherwise it could cause injuries or accidents.

- 1) Wipe the front panel with a soft paper towel to remove the dirt.
- 2) Do not apply any chemicals such as paint, benzine, aromatic liquid, pesticides etc., on the product.

## 5. Included Items

- Sensor unit
  - Fall prevention wire, installation washer, installation screw
  - Wiring fixation cramp, installation screw
  - Password for software download
- ※The below software and manuals can be downloaded on the official home page.
- USB Drivers (XP, Vista) (Dimagerusb.inf, Dimagerusb.sys)
  - Range Image Display Software (DigiCapUSB.exe)
  - Library for Application Software Development (Dimagerdll.h, Dimagerdll.lib, Dimagerdll.dll)
  - User's Manual (this document)
  - Instruction Manual for library Dimagerdll.dll

## 6. Parts Name

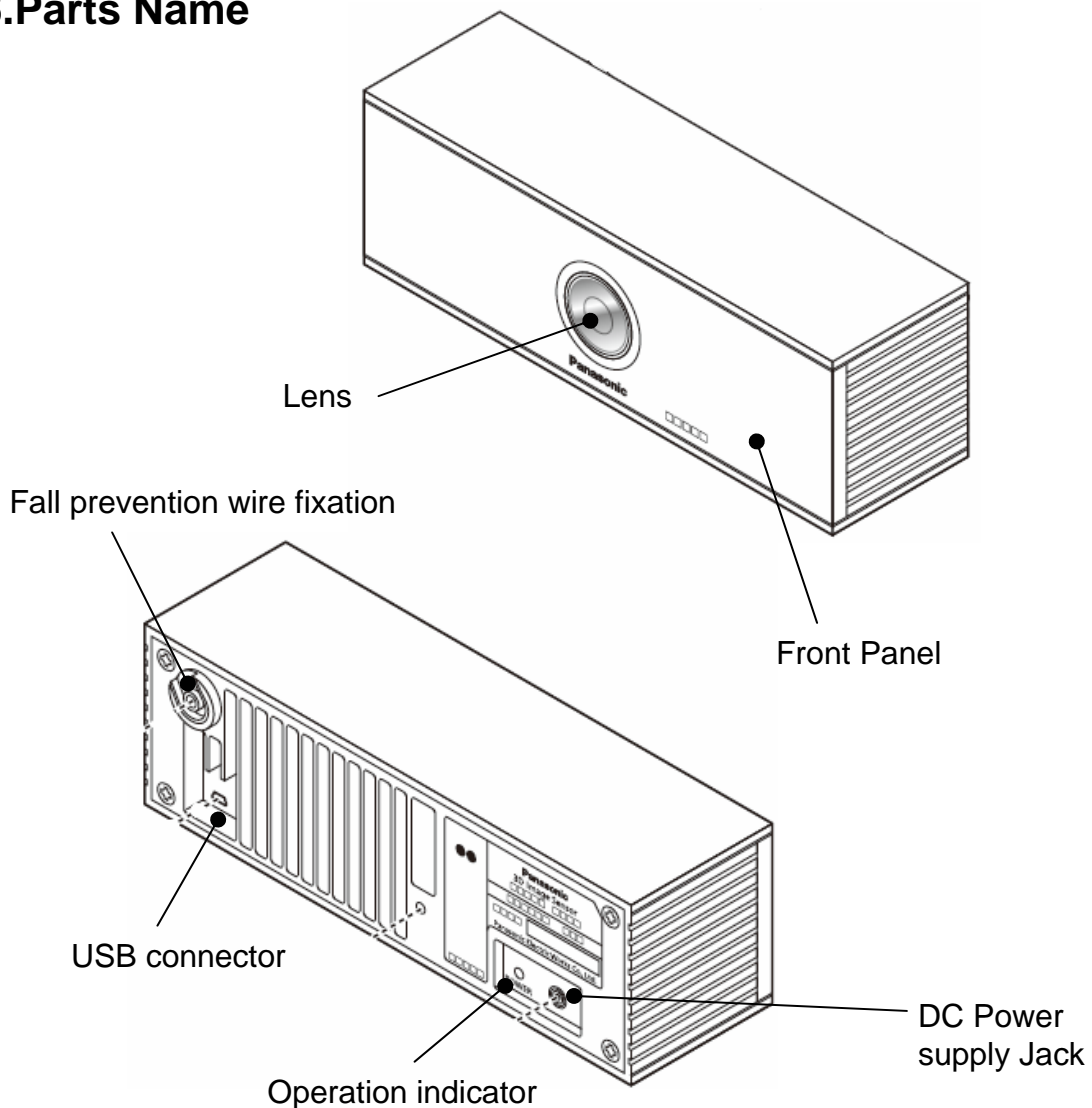

## 7. Device Installation

### 7.1 System Composition

1) Recommended configuration (PC)

- OS : Windows® XP (Service Pack1, Service Pack2, Service Pack3) 32bit  
Windows Vista® SP1 32bit
- CPU : Pentium® 4, Pentium® M 1GHz or more
- ※ At least one available USB 2.0 port

2) AC Adaptor (Not provided with the product)

- Output Voltage: 17.1-25.2V
- Output Current: >2A
- DC Jack type: EIAJ RC-5320A Voltage class5
- Polarity: 

3) USB2.0 cable (Not provided with the product)

USB mini-B Type plug ⇔ USB interface for PC  
(Less than 5m(16.4ft) )

### 7.2 Connection Example

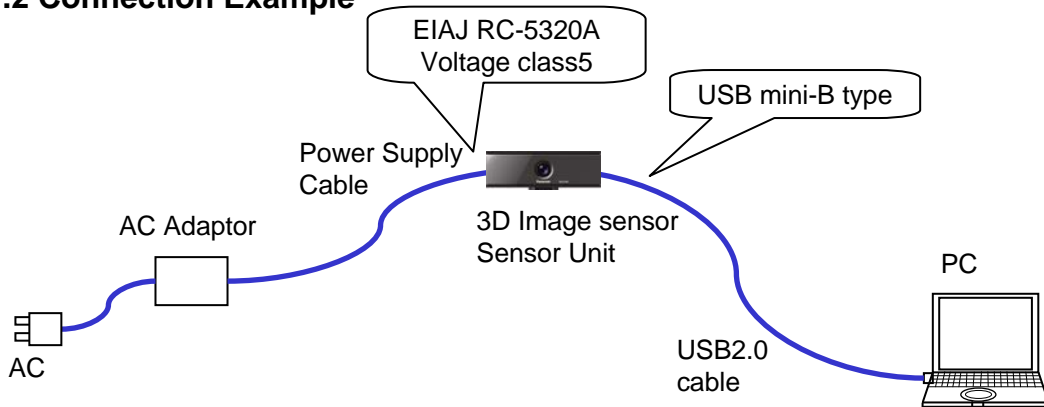

Note 1) Depending on the network environment or other applications etc., the sensor may not function.

Note 2) If you use simultaneously an other USB connected device, this product may not function properly.

### 7.3 Installation Process

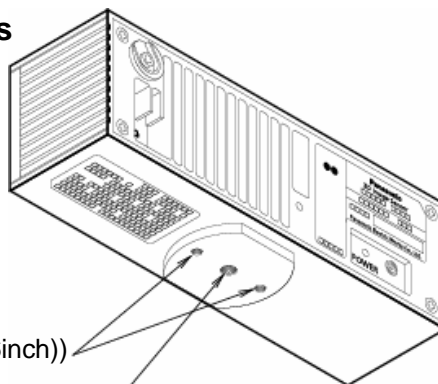

M4 (Screw depth > 6.0mm(0.236inch))

W1/4 (Screw depth > 6.0mm(0.236inch))

• When installing the 3D Image Sensor, fix it firmly by using either one ¼ inch screw or 2 M4 screws.

• Fixation screw length is recommended to be set to 4.0 to 6.0mm depth into the screw hole. Otherwise the sensor might not be properly fixed.

### ■ Wiring Fixation Cramp Installation Method

Use the wiring fixation cramp to prevent disconnection of the USB and power supply connectors.

- 1) Plug-in the USB and power supply connector into the sensor unit.
- 2) Cross the cables and attach the wiring fixation cramp at the intersection.  
Use the provided M3 screw to fix the cramp to the sensor unit.

※Avoid over-bending the cables during fixation. It may cause disconnections in the cable, resulting in smoke emissions or result in a fire.

### ■ Fall Prevention Wire Installation Method

Always use the fall prevention wire to avoid falls when installing the sensor unit in high places. Please work with care in high place.

- 1) Wrap the wire around a secure place (that could stop a fall) and insert one extremity's ring into the other.
- 2) Attach the ring that went through the other to the gutter located at the upper-left of the sensor unit.
- 3) Place the provided washer above it and fix it with the provided M3 screw.  
(Do not press down too strongly the washer on the wire. It might result in a rupture of the wire.)

※The fall prevention wire's length is 50cm. Always ensure the sensor unit is fixed in a safe position and adjust the length accordingly.

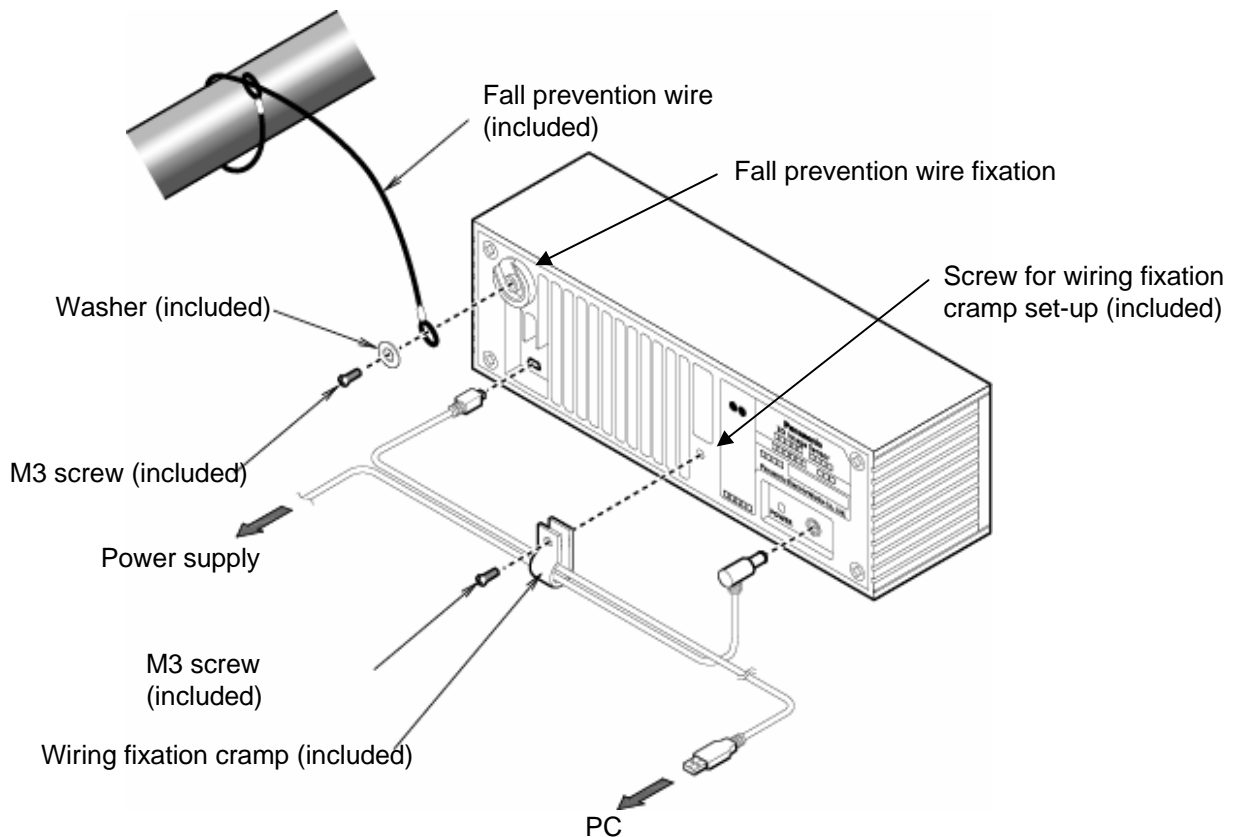



## 8.Startup and Shutdown Procedures

### 8.1 Startup Procedure

The following screenshots are from Windows XP. The process is the same for windows Vista.

1) Connect the USB of the PC and 3D image sensor.

2) Turn on the power supply of the 3D image sensor.

\*Turn on the power supply of the 3D image sensor only after the PC has been turned on.

3)The window for the New Hardware Detection Wizard will appear on the PC screen only when the main unit is connected and has been started up the first time. Please install according to the given procedure.

\*The connecting Wizard may appear this time or every time, depending on the Wizard. In any case, please follow the same procedure.



4) Select "Install from a list or specific location (Advanced)" and click "Next."

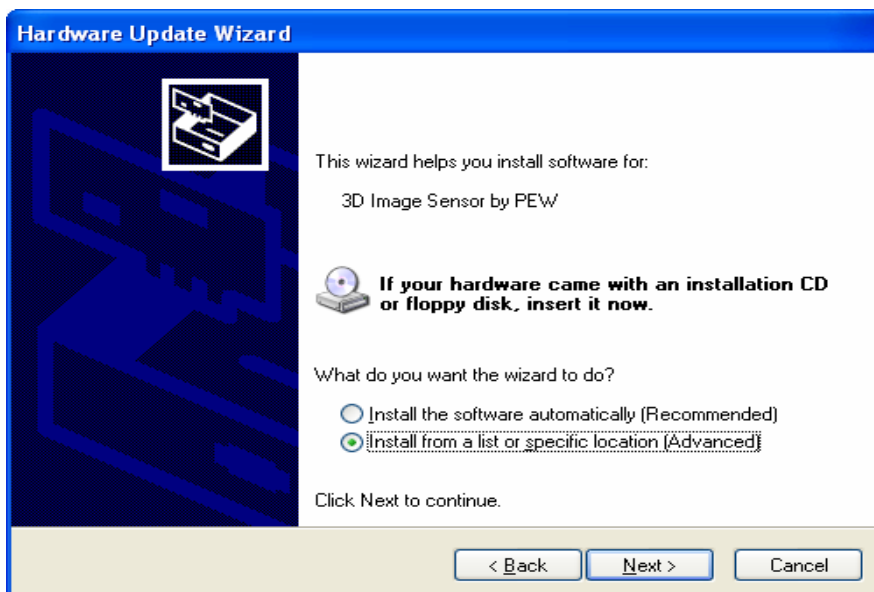

- 5) Designate the location of the downloaded Dimagerusb.ini and Dimagerusb.sys and click "Next."  
(The screen shows an example where the above files are stored in the C: ¥Dimager folder.)

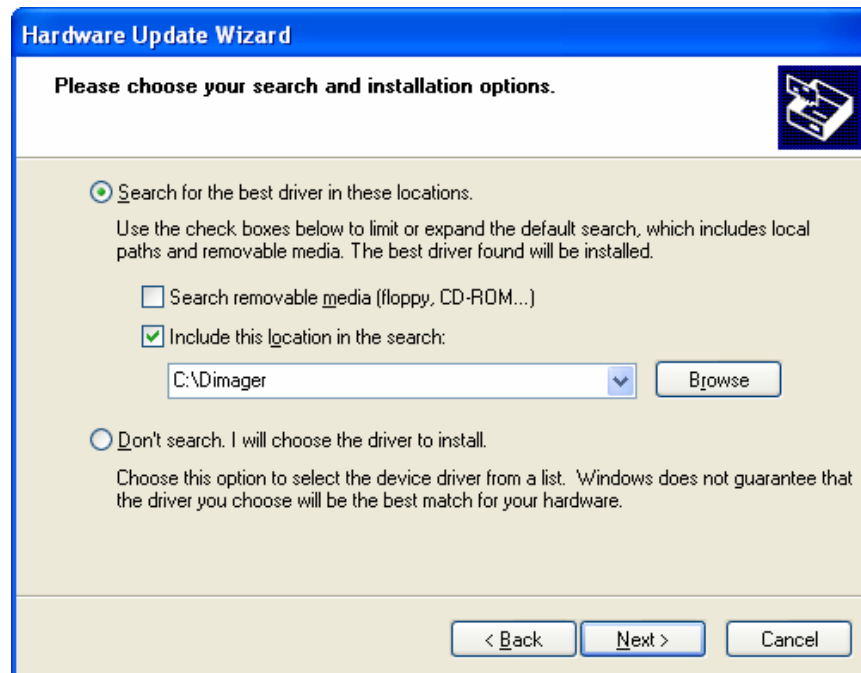

- 6) Found New Hardware Wizard is displayed, and then hardware Installation is displayed. Click "Continue Anyway."

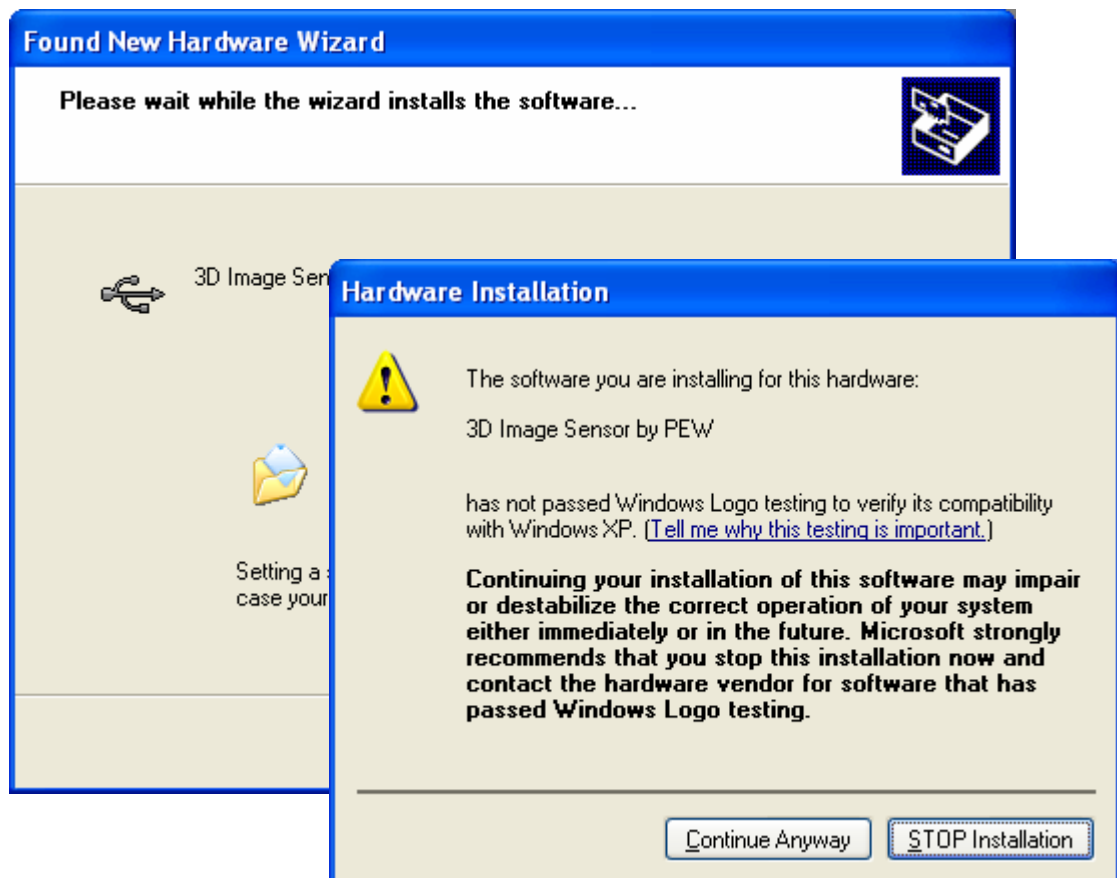

7) Completing the Found New Hardware Wizard is displayed in the Found New Hardware Wizard, and the install is complete.

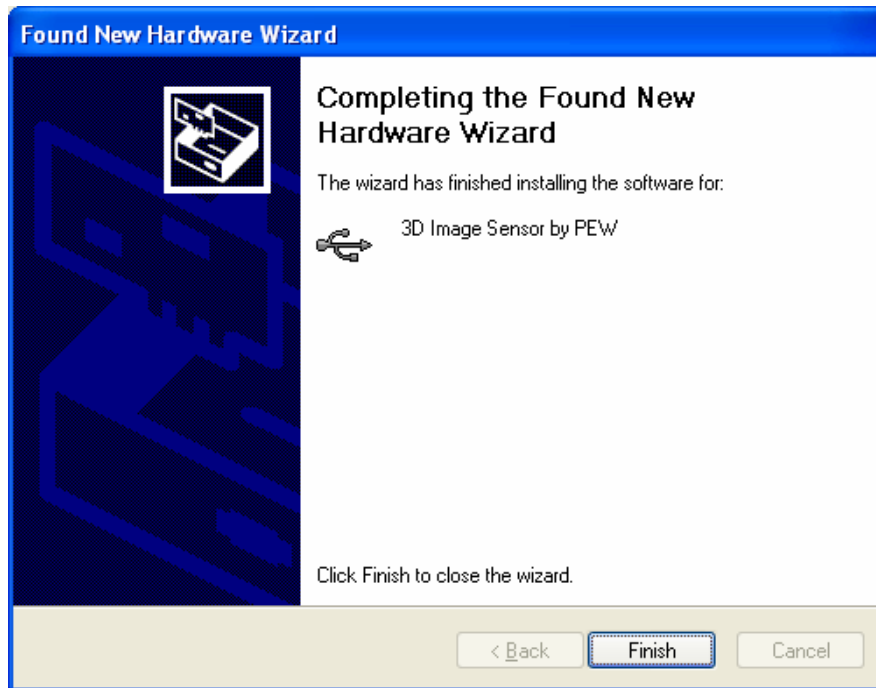

\*This installation is omitted at the second and all subsequent connections.

However, for PCs with multiple USB ports, this recognition/setting change window may appear again if you insert the USB cable into another USB port and switch the power on. If this happens, install using the same procedure.

\*The connecting Wizard may appear this time or every time, depending on the Wizard. In any case, please follow the same procedure.

## 8.2 Shutdown Procedure

- 1) If the image display software is running on the PC, stop the display, and close the image display program.
- 2) Disconnect the 3D image sensor power supply and the USB.

\* Turn OFF the power supply of the 3D image sensor while the PC power is still on.

## 9. Specifications

### 9.1 Dimensions

Height: 54mm Width: 170mm Depth: 49mm (except protuberance)

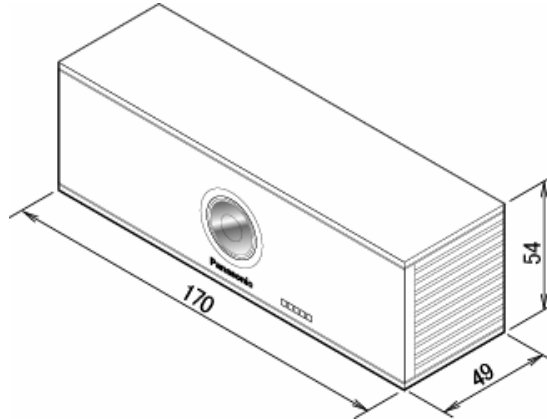

### 9.2 Basic Specifications

		Value	Special Mention
Operating Range		1.2m ~ 9.0m 3.94ft ~ 29.53ft	For a 0 lx ambient illumination and a 90% near-infrared reflectance of target object (20fps)
Field of View	Horizontal	Approx. 60°	—
	Vertical	Approx. 44°	
Pixel Array Size	Horizontal	160 Pixel	—
	Vertical	120 Pixel	—
Frame Rate		15fps, 20fps, 25fps, 30fps (Default: 20fps)	The frame rate can be switched with the application software. ※Please note characteristics is changed per the frame rate.
Range Resolution		1) $\sigma = 3\text{cm}(1.57\text{inch})(\text{max})$ (Ambient Illumination : 0lx) 2) $\sigma = 14\text{cm}(11.81\text{inch})(\text{max})$ (Ambient Illumination : 20,000lx)	【Measuring Conditions】 Ambient temperature 25°C(77° F), distance 2m (6.56ft) ,90% near-infrared reflectance target object, at central pixel.(20fps)  ※Depend on the environment and distance.
Absolute accuracy		+/-4cm(+/-1.57inch) (typ.) (Ambient Illumination : 0lx)	
Modulation Frequency		3 modes	Mode selection is available using application software. It can be used to avoid interferences between different systems using 3D Image Sensors close by.
Operating Ambient Illumination		(Sunlight) 20,000lx and less	—

		Value	Special Mention
Output Type	Range Data	11bit	USB2.0 (Hi-Speed USB only)
	Image Data	8bit	
Connector		USB(mini-B type)	
Operating Temperature		-10°C ~ +50°C 14° F ~ 122° F	Avoid condensation or freezing
Operating Voltage	Maximum	25.2VDC	—
	Typical	18.0VDC	
	Minimum	17.1VDC	
Current Consumption		0.4A (Avg.) (sleep period: 0.15A)	0.9A (Peak)
Illumination (LED)	Wavelength	850nm (typ.)	In accordance with the IEC60825-1:2005 Class 1
	Output power	0.5W (Avg.)	
Weight		Approx. 520g	Sensor Unit only

\*Indoor usage only. Cannot be used outdoors.

## 10.Provision on Export Trade Control

- 1) CUSTOMER shall not use this PRODUCT for any military purpose.
- 2) CUSTOMER shall screen its own customers to determine their potential involvement in uses related to MILITARY ACTIVITIES, and restrict each from reselling or retransferring the GOODS or TECHNOLOGY, directly or indirectly, to any customer who was, is or may be engaged in development, design, manufacture, use or storage of the WEAPONS OF MASS DESTRUCTION.
- 3) CUSTOMER shall not export or re-export the GOODS or TECHNOLOGY, directly or indirectly, to any country against which any sanction is imposed under certain resolutions of the Security Council of the United Nations, as long as such resolutions remain valid and effective and as far as the GOODS or TECHNOLOGY remain prohibited to be exported to such country.
- 4) In the event CUSTOMER breaches any provision of this Article, CUSTOMER shall be liable for any and all direct and indirect damages incurred by Panasonic Electric Works Co., Ltd. ("PEW") arising from such breach, and, notwithstanding anything herein contained to the contrary, PEW shall have the right to terminate this AGREEMENT forthwith without any liability to CUSTOMER. Furthermore, PEW is not obligated to accept or fulfill any order which might contravene any export control laws, rules and/or regulations of any relevant country, or the provisions of this Article.

## 11.Special Notice

As improvements are continually being made, the specifications or design of this product are subject to change without notice.

Please strictly follow the "Safety Precautions" and "Operating Precautions" on the specifications sheet. Normal functioning cannot be expected if used in environments or conditions other than those specified above.

We are deeply committed to providing the highest quality control for this product. Nevertheless:

1)To reduce the risk of harm caused by product failure to human life or assets, this product should always be used in conjunction with other safety measures, such as protective circuitry, double layered circuit boards, etc., and used within the guaranteed performance, efficiency or special characteristics values stated in the specification sheet.

2)This product is warranted for a period of one year, from date of delivery, applicable only if the product is used in accordance with the precautions mentioned above and the specifications sheet. We will replace any malfunctioning product if such defect or malfunction is caused by us.

However, the above warranty shall be void in the following circumstances:

- a) Damage caused to something else than the product itself.
- b) Resulting from misuse of the product (use not in accordance with the precautions mentioned above and this specifications sheet).
- c) Resulting from a fall, during relocation, transportation, or handling at the installation location, after the date of purchase
- d) Phenomenon unforeseeable in the state of the technology as of the supply date.
- e) Caused by natural or unnatural events such as fire, earthquake, flood, thunderbolt, or other natural disasters, pollution, salt air damage, gas damage (sulfuric acid gas etc.), abnormal voltage, usage of a non-specified power supply (in frequency or voltage), etc.
- f) Resulting from installation or use in moving vehicles (automobiles, ships, airplanes, etc.)
- g) Resulting from improper preparation, installation, or modification.
- h) Damage resulting from the use in conjunction with an other company's product.
- i) Intellectual property or privacy claims based on the use of images recorded using the sensor.

## X-ON Electronics

Largest Supplier of Electrical and Electronic Components

*Click to view similar products for [panasonic](#) manufacturer:*

Other Similar products are found below :

[ECE-A1HKAR47](#) [ELC-09D151F](#) [HC2-H-DC48V-F](#) [HL2-HP-AC120V-F](#) [HL2-H-DC12V-F](#) [HL2-HP-DC12V-F](#) [HL2-HP-DC6V-F](#) [HL2-HP-DC24V-F](#) [HL2-H-DC110V-F](#) [HC4-H-DC24V](#) [HL2-HTM-DC24V-F](#) [HL2-HTM-AC24V-F](#) [HC4-H-AC24V](#) [HC4-H-AC120V](#) [HC4-H-DC12V](#) [AZH2031](#) [RP-SDMF64DA1](#) [EVM-F6SA00B55](#) [RP-SMLE08DA1](#) [ERZ-V20R391](#) [ELL-ATV681M](#) [LC-R121R3P](#) [ERZ-V05V680CB](#) [LT4H-DC24V](#) [LT4HL8-AC24V](#) [LT4HW-AC24V](#) [LT4HWT8-AC240V](#) [LT4HWT-AC240VS](#) [CY-122A-P](#) [ETQ-P5M470YFM](#) [EVAL\\_PAN1555](#) [EVQ-PAE04M](#) [EX-14B](#) [EX-22B-PN](#) [EX-31A-C5](#) [EXB-24N121JX](#) [EX-F72-PN](#) [EX-L211](#) [EYG-A121803V](#) [FCR-M50-AC208V](#) [FC-SFBH-20](#) [FC-SFBH-24](#) [FD-F8Y](#) [MHMA102A1C](#) [MHMD022S1S](#) [MHMD041S1S](#) [MHMD042G1T](#) [MHMD082G1T](#) [FD-S9](#) [FP0-LDR](#)