



Multilayer ceramic capacitors

Chip capacitors, MLSC, X7R

Date: October 2006

Multilayer serial ceramic capacitor (MLSC)**General**

The MLSC was developed for typical applications with a direct connection to the battery or generator in the automobile, as it satisfies the requirements of the automobile manufacturers for a series connection of two capacitors for battery applications in a single component.

It not only represents the only real alternative to the series connection of discrete capacitors, but also offers advantages over these and other possible solutions, which contain only a single capacitor.

Compared with a series circuit made up of conventional ceramic capacitors, it allows the number of components to be reduced. This reduces the space requirement on the circuit board and shortens the placement time. Because fewer components are used, the failure probability is additionally reduced.

The MLSC is based on proven MLCC technology, but has a more rugged design. This technology offers highest reliability (ppb rate) on the basis of long field experience. Both undamaged and typically cracked MLSCs are characterized by a high breakdown voltage and high ESD and pulse strength.

It may be used at temperatures of up to 150 °C with consideration of a voltage derating and with brief temperature peaks of up to 175 °C without electrical stressing (refer to the Advanced series).

Like the capacitors of the Advanced series, the MLSC is also manufactured to the specifications of the ppb level assurance system, and a bending strength of 2 mm is assured on the basis of the rigorous piezoelectric method.

Ordering code system

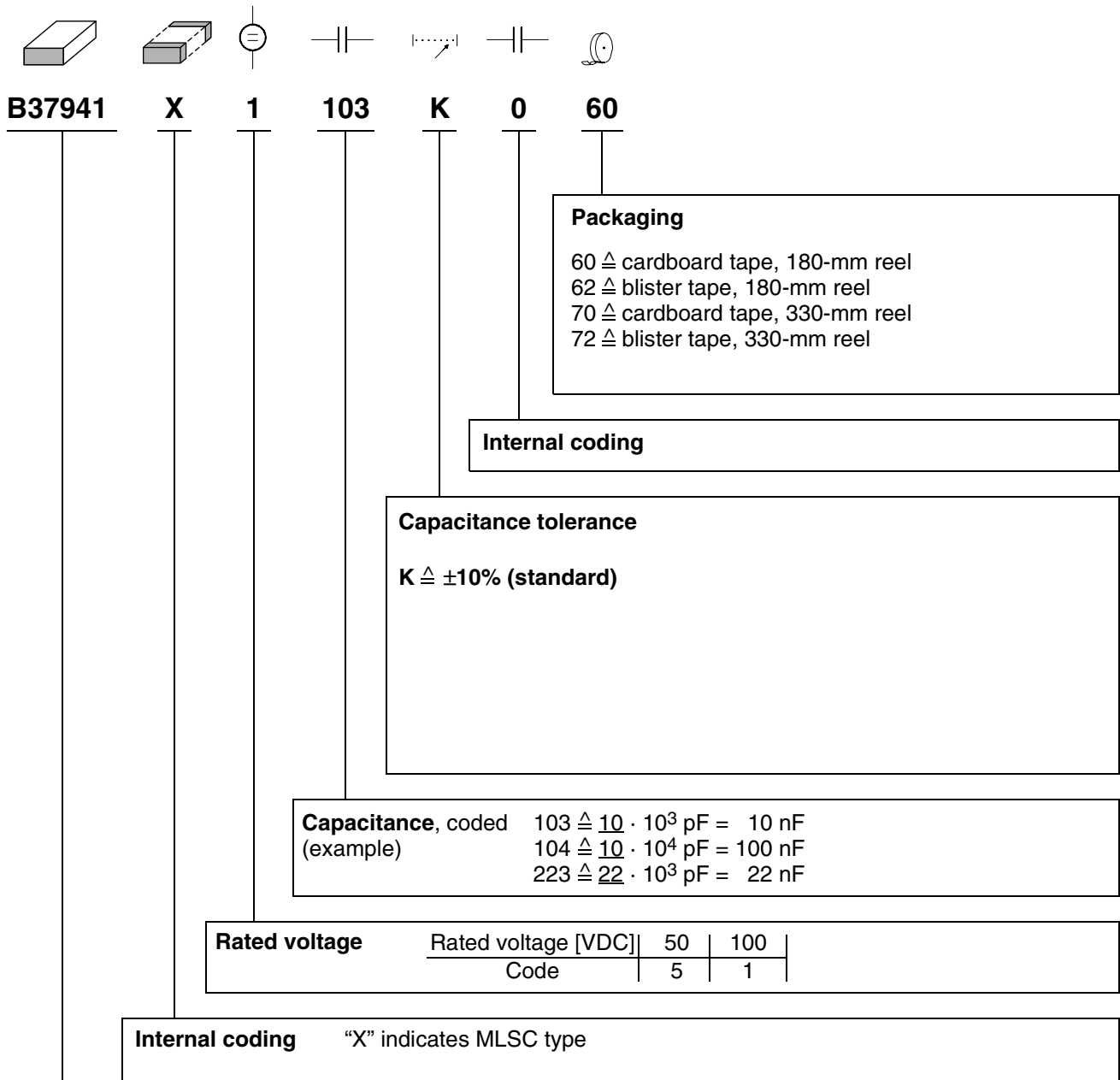

Type and size	
Chip size (inch / mm)	Temperature characteristic X7R
0603 / 1608 0805 / 2012	B37931 B37941

Features

- Two series-connected ceramic capacitors in a single component
- The MLSC thus satisfies the requirements of the automobile manufacturers for applications on the battery / generator (e.g. clamp 30 or clamp 15) in a single component.
- Reduction of the effects of a
 - bending fracture
 - placement fracture
 - solder-shock crack
 thanks to a lower probability of a short circuit.
- Evaluation criteria: Insulation resistance >10 k after the following treatment bending until crack humidity tests (85 °C/85% RH, rated voltage), 14 days
- The breakdown voltage of MLSCs in the case of a typical bending crack is still greater than five times the rated voltage.
- Both undamaged and cracked MLSCs are capable of fulfilling the requirements to ISO7637 for 12 V automotive power systems, including load-dump and jump-start requirements (24 V/1 h and 36 V/1 h).
- To AEC-Q200

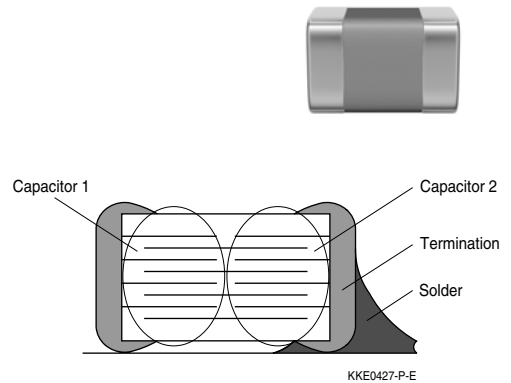

Applications

- Automobile electronics
 - for direct connection to the car battery or generator
 - at positions with “stranding potential”
 - as RF filters in small motors (e.g. electrically operated windows)
- Power electronics (e.g. DC/DC converters)
- Smoothing capacitors (e.g. on the rechargeable battery in mobile equipment)

Cautions

A short circuit cannot be completely excluded. The use of MLSCs does not therefore result in 100% fail-safe operation, but in the event of a crack the probability of a short circuit can be greatly reduced. In the event of an untypical (bending) crack formation (e.g. double-sided crack or extreme mounting crack) and other mechanical or thermal damage to the capacitor, the capacitor may have a low ohmic state.

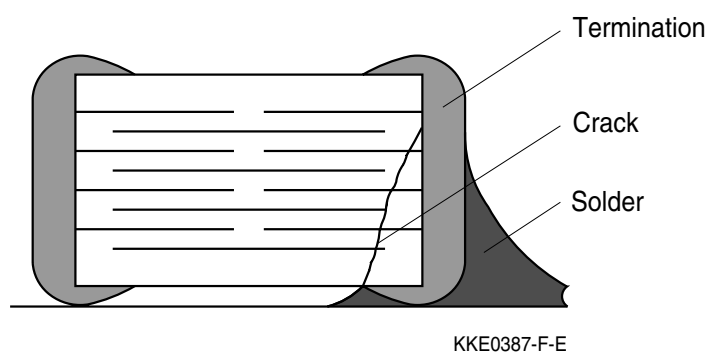

Termination

- For soldering: Nickel barrier termination (Ni)

Delivery mode

- Cardboard and blister tape (blister tape for chip thickness $\geq 1.2 \pm 0.1$ mm), 180-mm and 330-mm reel available

Electrical data

Temperature characteristic		X7R	
Max. relative capacitance change within -55 °C to $+125\text{ °C}$	$\Delta C/C$	± 15	%
Climatic category (IEC 60068-1)		55/125/56	
Standard		EIA	
Dielectric		Class 2	
Rated voltage ¹⁾	V_R	50, 100	VDC
Test voltage	V_{test}	$2.5 \cdot V_R/5$ s	VDC
Capacitance range / E series	C_R	1 nF ... 100 nF (E6)	
Dissipation factor (limit value)	$\tan \delta$	$< 25 \cdot 10^{-3}$	
Insulation resistance ²⁾ at $+ 25\text{ °C}$	R_{ins}	$> 10^5$	M Ω
Insulation resistance ²⁾ at $+125\text{ °C}$	R_{ins}	$> 10^4$	M Ω
Time constant ²⁾ at $+ 25\text{ °C}$	τ	> 1000	s
Time constant ²⁾ at $+125\text{ °C}$	τ	> 100	s
Operating temperature range	T_{op}	$-55 \dots +125$	$^{\circ}\text{C}$
Ageing ³⁾		yes	

1) Note: No operation on AC line.

2) For $C_R > 10$ nF the time constant $\tau = C \cdot R_{\text{ins}}$ is given.

3) Refer to chapter "General technical information", "Ageing".

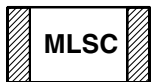

Multilayer ceramic capacitors

MLSC; X7R

Capacitance tolerances

Code letter	K (standard)
Tolerance	$\pm 10\%$

Dimensional drawing

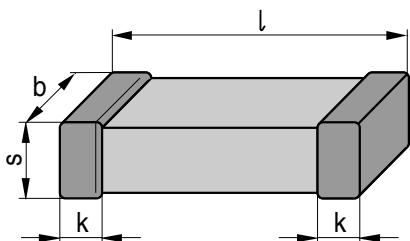

KKE0329-N

Dimensions (mm)

Case size	(inch)	0603	0805
	(mm)	1608	2012
l		1.6 ± 0.15	2.00 ± 0.20
b		0.8 ± 0.10	1.25 ± 0.15
s		0.8 ± 0.10	1.35 max.
k		$0.1 - 0.40$	$0.13 - 0.75$

Tolerances to CECC 32101-801

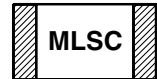

Recommended solder pad

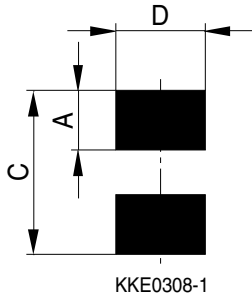

Recommended dimensions (mm) for reflow soldering

Case size (inch/mm)	Type	A	C	D
0603/1608	single chip	0.6 ... 0.7	1.8 ... 2.2	0.6 ... 0.8
0805/2012	single chip	0.6 ... 0.7	2.2 ... 2.6	0.8 ... 1.1

Recommended dimensions (mm) for wave soldering

Case size (inch/mm)	Type	A	C	D
0603/1608	single chip	0.8 ... 0.9	2.2 ... 2.8	0.6 ... 0.8
0805/2012	single chip	0.9 ... 1.0	2.8 ... 3.2	0.8 ... 1.1

Termination

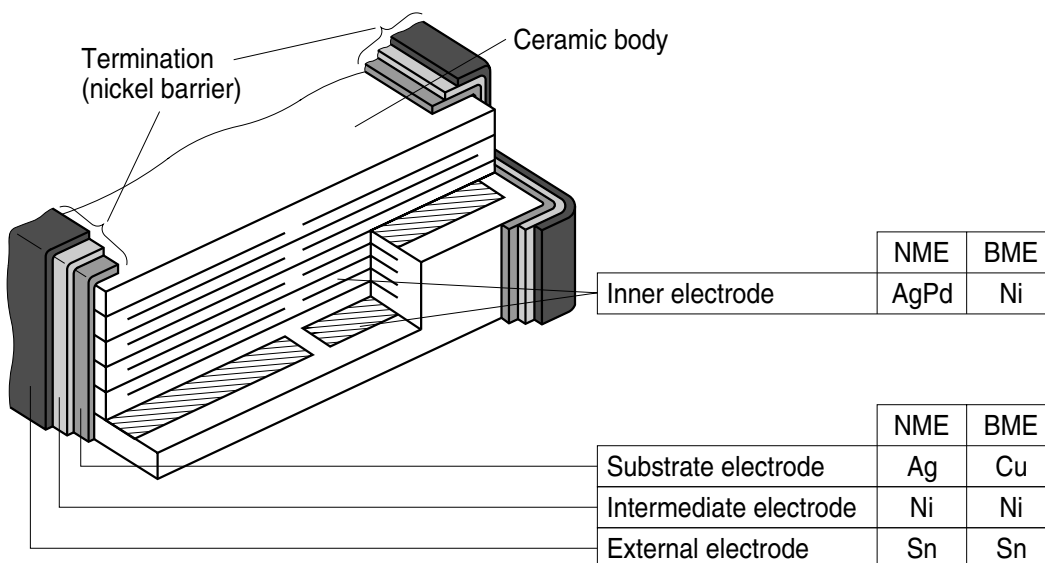

NME: Noble Metal Electrode
BME: Base Metal Electrode

KKE0407-Y-E

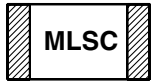
Multilayer ceramic capacitors
MLSC; X7R
Product range for MLSC chip capacitors, X7R

Size ¹⁾	0603		0805	
inch	1608		2012	
mm				
Type	B37931		B37941	
V_R (VDC)	50		50	100
C_R				
1.0 nF				
1.5 nF				
2.2 nF				
3.3 nF				
4.7 nF				
6.8 nF				
10 nF				
15 nF				
22 nF				
33 nF				
47 nF				
68 nF				
100 nF				

1) l × b (inch) / l × b (mm)

Ordering codes and packing for X7R, 50 and 100 VDC, nickel barrier terminations

C _R ¹⁾	Ordering code	Chip thickness mm	Cardboard tape, Ø 180-mm reel	Cardboard tape, Ø 330-mm reel
			** \triangleq 60	** \triangleq 70
			pcs/reel	pcs/reel

Case size 0603, 50 VDC

1.0 nF	B37931X5102K0**	0.8 ±0.1	4000	16000
1.5 nF	B37931X5152K0**	0.8 ±0.1	4000	16000
2.2 nF	B37931X5222K0**	0.8 ±0.1	4000	16000
3.3 nF	B37931X5332K0**	0.8 ±0.1	4000	16000
4.7 nF	B37931X5472K0**	0.8 ±0.1	4000	16000
6.8 nF	B37931X5682K0**	0.8 ±0.1	4000	16000
10 nF	B37931X5103K0**	0.8 ±0.1	4000	16000

Case size 0805, 50 VDC

33 nF	B37941X5333K0**	0.8 ±0.1	4000	16000
47 nF	B37941X5473K0**	0.8 ±0.1	4000	16000
68 nF	B37941X5683K0**	1.25 ± 0.1	3000 ²⁾	12000 ³⁾
100 nF	B37941X5104K0**	1.25 ± 0.1	3000 ²⁾	12000 ³⁾

Case size 0805, 100 VDC

1.0 nF	B37941X1102K0**	0.8 ±0.1	4000	16000
1.5 nF	B37941X1152K0**	0.8 ±0.1	4000	16000
2.2 nF	B37941X1222K0**	0.8 ±0.1	4000	16000
3.3 nF	B37941X1332K0**	0.8 ±0.1	4000	16000
4.7 nF	B37941X1472K0**	0.8 ±0.1	4000	16000
6.8 nF	B37941X1682K0**	0.8 ±0.1	4000	16000
10 nF	B37941X1103K0**	0.8 ±0.1	4000	16000
15 nF	B37941X1153K0**	0.8 ±0.1	4000	16000
22 nF	B37941X1223K0**	0.8 ±0.1	4000	16000

1) Other capacitance values on request.

2) Blister tape, 180-mm reel, ordering code ** \triangleq 62

3) Blister tape, 330-mm reel, ordering code ** \triangleq 72



Multilayer ceramic capacitors

MLSC; X7R

Typical characteristics¹⁾

Capacitance change $\Delta C/C_{25}$ versus temperature T

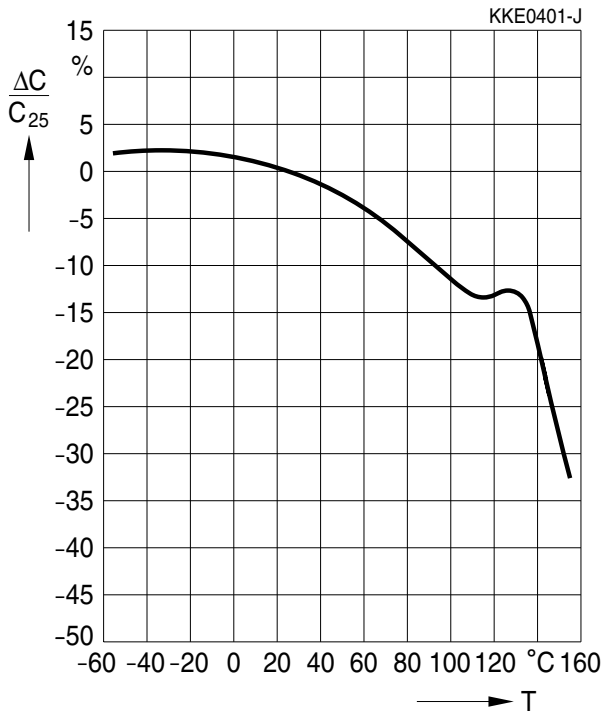

Capacitance change $\Delta C/C_0$ versus superimposed DC voltage V

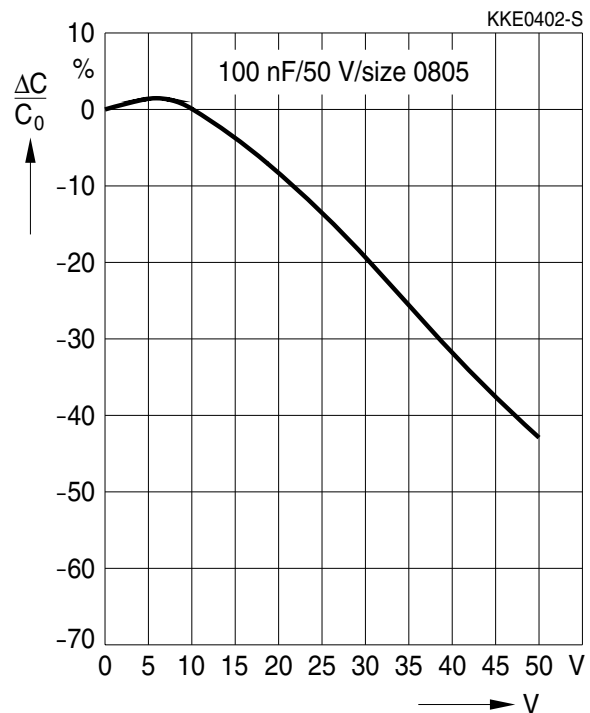

Impedance |Z| versus frequency f for case size 0603

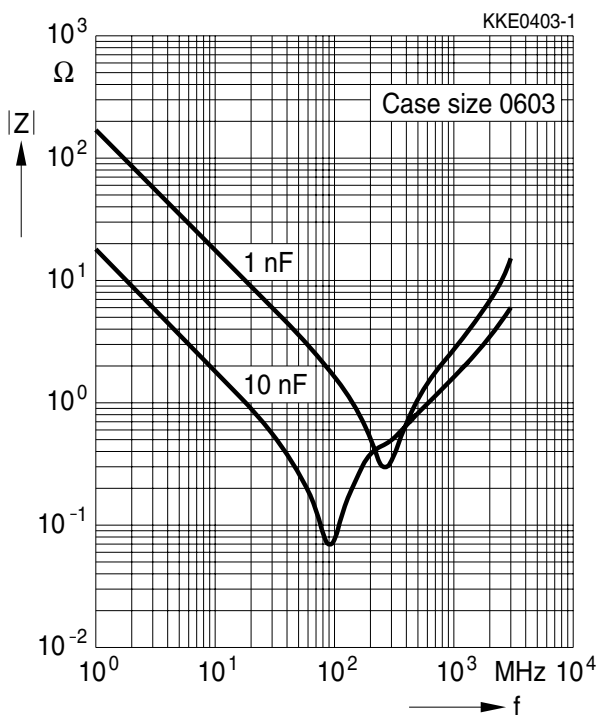

Impedance |Z| versus frequency f for case size 0805

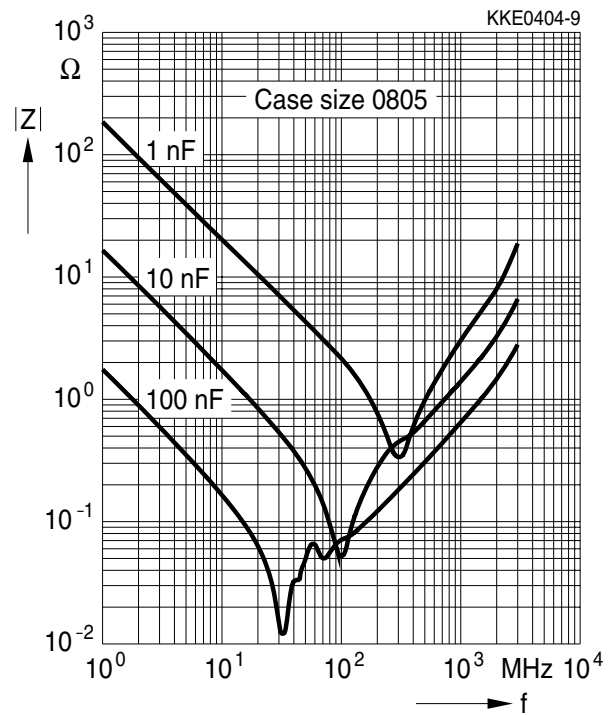

1) For more detailed information on frequency behavior and characteristics see www.epcos.com/mlcc_impedance.

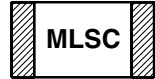

Typical characteristics¹⁾

Dissipation factor $\tan \delta$ versus temperature T

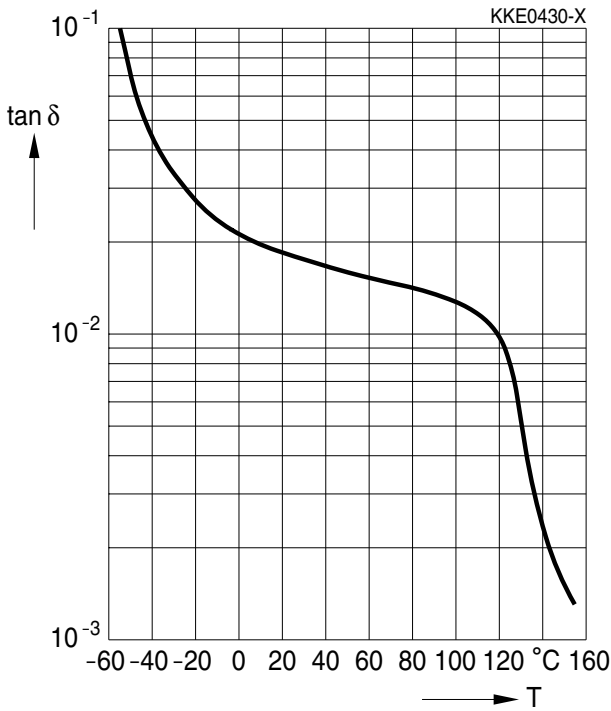

Insulation resistance R_{ins} versus temperature T

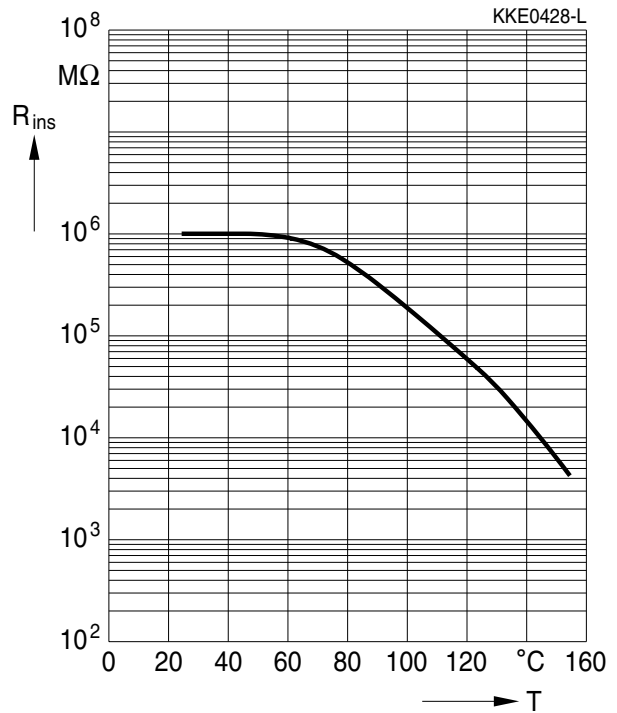

Capacitance change $\Delta C/C_1$ versus time t

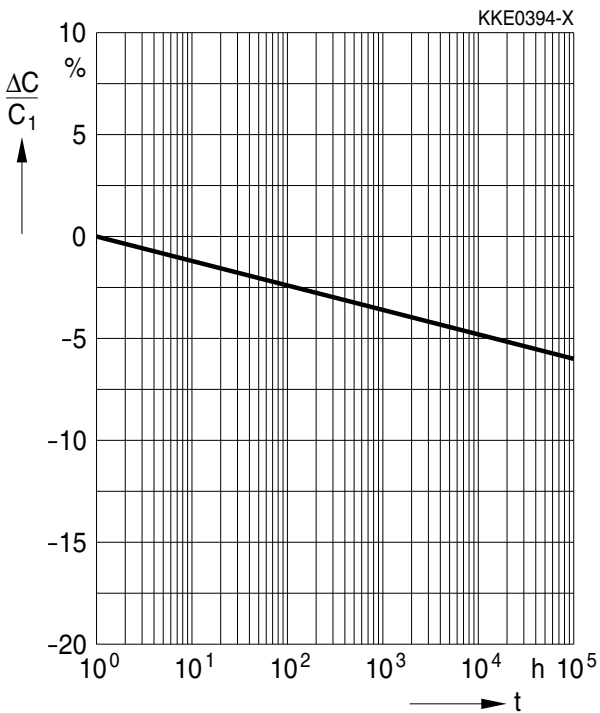

1) For more detailed information on frequency behavior and characteristics see www.epcos.com/mlcc_impedance.

Notes on the selection of ceramic capacitors

In the selection of ceramic capacitors, the following criteria must be considered:

1. Depending on the application, ceramic capacitors used to meet high quality requirements should at least satisfy the specifications to AEC-Q200. They must meet quality requirements going beyond this level in terms of ruggedness (e.g. mechanical, thermal or electrical) in the case of critical circuit configurations and applications (e.g. in safety-relevant applications such as ABS and airbag equipment or durable industrial goods).
2. At the connection to the battery or power supply (e.g. clamp 15 or 30 in the automobile) and at positions with stranding potential, to reduce the probability of short circuits following a fracture, two ceramic capacitors must be connected in series and/or a ceramic capacitor with integrated series circuit should be used. The MLSC from EPCOS contains such a series circuit in a single component.
3. Ceramic capacitors with the temperature characteristics Z5U and Y5V do not satisfy the requirements to AEC-Q200 and are mechanically and electrically less rugged than COG or X7R/X8R ceramic capacitors. In applications that must satisfy high quality requirements, therefore, these capacitors should not be used as discrete components (see the chapter “Effects on mechanical, thermal and electrical stress”, point 1.4).
4. For ESD protection, preference should be given to the use of multilayer varistors (MLV) (see the chapter “Effects on mechanical, thermal and electrical stress”, point 1.4).
5. An application-specific derating or continuous operating voltage must be considered in order to cushion (unexpected) additional stresses (see the chapter “Reliability”).

The following should be considered in circuit board design

1. If technically feasible in the application, preference should be given to components having an optimal geometrical design.
2. At least FR4 circuit board material should be used.
3. Geometrically optimal circuit boards should be used, ideally those that cannot be deformed.
4. Ceramic capacitors must always be placed a sufficient minimum distance from the edge of the circuit board. High bending forces may be exerted there when the panels are separated and during further processing of the board (such as when incorporating it into a housing).
5. Ceramic capacitors should always be placed parallel to the possible bending axis of the circuit board.
6. No screw connections should be used to fix the board or to connect several boards. Components should not be placed near screw holes. If screw connections are unavoidable, they must be cushioned (for instance by rubber pads).

The following should be considered in the placement process

1. Ensure correct positioning of the ceramic capacitor on the solder pad.
2. Caution when using casting, injection-molded and molding compounds and cleaning agents, as these may damage the capacitor.
3. Support the circuit board and reduce the placement forces.
4. A board should not be straightened (manually) if it has been distorted by soldering.
5. Separate panels with a peripheral saw, or better with a milling head (no dicing or breaking).
6. Caution in the subsequent placement of heavy or leaded components (e.g. transformers or snap-in components): danger of bending and fracture.
7. When testing, transporting, packing or incorporating the board, avoid any deformation of the board not to damage the components.
8. Avoid the use of excessive force when plugging a connector into a device soldered onto the board.
9. Ceramic capacitors must be soldered only by the mode (reflow or wave soldering) permissible for them (see the chapter "Soldering directions").
10. When soldering the most gentle solder profile feasible should be selected (heating time, peak temperature, cooling time) in order to avoid thermal stresses and damage.
11. Ensure the correct solder meniscus height and solder quantity.
12. Ensure correct dosing of the cement quantity.
13. Ceramic capacitors with an AgPd external termination are not suited for the lead-free solder process: they were developed only for conductive adhesion technology.

This listing does not claim to be complete, but merely reflects the experience of EPCOS AG.

The following applies to all products named in this publication:

1. Some parts of this publication contain **statements about the suitability of our products for certain areas of application**. These statements are based on our knowledge of typical requirements that are often placed on our products in the areas of application concerned. We nevertheless expressly point out **that such statements cannot be regarded as binding statements about the suitability of our products for a particular customer application**. As a rule, EPCOS is either unfamiliar with individual customer applications or less familiar with them than the customers themselves. For these reasons, it is always ultimately incumbent on the customer to check and decide whether an EPCOS product with the properties described in the product specification is suitable for use in a particular customer application.
2. We also point out that **in individual cases, a malfunction of passive electronic components or failure before the end of their usual service life cannot be completely ruled out in the current state of the art, even if they are operated as specified**. In customer applications requiring a very high level of operational safety and especially in customer applications in which the malfunction or failure of a passive electronic component could endanger human life or health (e.g. in accident prevention or life-saving systems), it must therefore be ensured by means of suitable design of the customer application or other action taken by the customer (e.g. installation of protective circuitry or redundancy) that no injury or damage is sustained by third parties in the event of malfunction or failure of a passive electronic component.
3. **The warnings, cautions and product-specific notes must be observed.**
4. In order to satisfy certain technical requirements, **some of the products described in this publication may contain substances subject to restrictions in certain jurisdictions (e.g. because they are classed as “hazardous”)**. Useful information on this will be found in our Material Data Sheets on the Internet (www.epcos.com/material). Should you have any more detailed questions, please contact our sales offices.
5. We constantly strive to improve our products. Consequently, **the products described in this publication may change from time to time**. The same is true of the corresponding product specifications. Please check therefore to what extent product descriptions and specifications contained in this publication are still applicable before or when you place an order.
We also **reserve the right to discontinue production and delivery of products**. Consequently, we cannot guarantee that all products named in this publication will always be available.
6. Unless otherwise agreed in individual contracts, **all orders are subject to the current version of the “General Terms of Delivery for Products and Services in the Electrical Industry” published by the German Electrical and Electronics Industry Association (ZVEI)**.
7. The trade names EPCOS, EPCOS-JONES, Baoke, CeraDiode, CSSP, MLSC, PhaseCap, PhaseMod, SIFERRIT, SIFI, SIKOREL, SilverCap, SIMID, SIOV, SIP5D, SIP5K, UltraCap, WindCap are **trademarks registered or pending** in Europe and in other countries. Further information will be found on the Internet at www.epcos.com/trademarks.

X-ON Electronics

Largest Supplier of Electrical and Electronic Components

Click to view similar products for [Multilayer Ceramic Capacitors MLCC - SMD/SMT](#) category:

Click to view products by [EPCOS](#) manufacturer:

Other Similar products are found below :

[M39014/01-1467](#) [M39014/02-1218V](#) [M39014/02-1225V](#) [M39014/02-1262V](#) [M39014/02-1301](#) [M39014/22-0631](#) [1210J5000102JCT](#)
[1210J2K00102KXT](#) [1210J5000103KXT](#) [1210J5000223KXT](#) [D55342E07B379BR-TR](#) [D55342E07B523DR-T/R](#) [1812J1K00103KXT](#)
[1812J1K00473KXT](#) [1812J2K00680JCT](#) [1812J4K00102MXT](#) [1812J5000102JCT](#) [1812J5000103JCT](#) [1812J5000682JCT](#) [NIN-FB391JTRF](#)
[NIN-FC2R7JTRF](#) [NPIS27H102MTRF](#) [C1206C101J1GAC](#) [C1608C0G1E472JT000N](#) [C2012C0G2A472J](#) [2220J2K00101JCT](#)
[KHC201E225M76N0T00](#) [LRC-LRF1206LF-01R025FTR1K](#) [1812J1K00222JCT](#) [1812J2K00102KXT](#) [1812J2K00222KXT](#)
[1812J2K00472KXT](#) [2-1622820-7-CUT-TAPE](#) [2220J3K00102KXT](#) [2225J2500824KXT](#) [CCR07CG103KM](#) [CGA2B2C0G1H010C](#)
[CGA2B2C0G1H040C](#) [CGA2B2C0G1H050C](#) [CGA2B2C0G1H060D](#) [CGA2B2C0G1H070D](#) [CGA2B2C0G1H151J](#) [CGA2B2C0G1H1R5C](#)
[CGA2B2C0G1H2R2C](#) [CGA2B2C0G1H3R3C](#) [CGA2B2C0G1H680J](#) [CGA2B2C0G1H6R8D](#) [CGA2B2X8R1H221K](#) [CGA2B2X8R1H472K](#)
[CGA3E1X7R1C474K](#)